

**TECHNICAL MANUAL**

**ORGANIZATIONAL  
MAINTENANCE**

**TRUCK TRACTOR, LINE HAUL,  
50,000 GVWR, 6 x 4, M915A1**

**(NSN 2320-01-125-2640)**

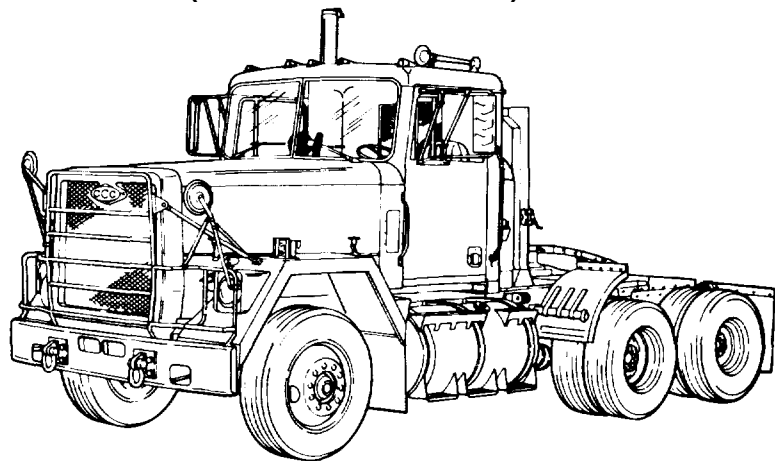

**HEADQUARTERS,  
DEPARTMENT OF THE ARMY**

**ELECTRICAL SYSTEM  
PAGE 3-384**

**TRANSMISSION  
PAGE 3-792**

**PROPELLER SHAFTS  
AND UNIVERSAL JOINTS  
PAGE 3-856**

**FRONT AXLE  
PAGE 3-876**

**REAR AXLE  
PAGE 3-896**

**BRAKE SYSTEM  
PAGE 3-908**

**DECEMBER 1983**

This manual may include copyrighted technical data of one or more of the following subcontractors of AM General Corporation:

01981	Alinabal, Division of MPB Corporation
01981	Anchorlock, Division of Lear Siegler, Inc.
01980	Argo Instruments, Inc.
01981	Bendix Corporation
01982	Bostrom, Division of UOP, Inc.
01976	The Budd Company
01982	Cole-Hersee Company
01982	Cummins Engine Company, Inc.
01980	Delco-Remy, Division of General Motors Corporation
01982	Detroit Diesel Allison, Division of General Motors Corporation
01981	Eaton Corporation, Axle Division
01981	Firestone Steel Products Company, Division of Firestone Tire and Rubber Company
01980	Goodyear Tire and Rubber Company
01981	Grote Manufacturing Company
01980	Gunite, Division of Kelsey-Hayes Co.
01981	Holland Hitch Company
01980	Hupp, Mobile Products Division
01981	Leece-Neville, Sheller Globe Division
01982	McCord Heat Transfer, Division of Ex-Cell-O Corporation
01979	Nelson Muffler, Division of Nelson Industries, Inc.
01982	Owatonna Tool Company
01979	Phillips Temco, Inc., Division of J.B. Carter
01982	Rockwell International
01978	Snap-On Tool Company

AM General has written permission from any and all such subcontractors holding copyrights to grant the United States Government a royalty free, non-exclusive and irrevocable license throughout the world for Governmental purposes to publish, translate, reproduce, deliver, perform, dispose of, and to authorize others so to do, all technical data now or hereafter covered by copyright. Any use other than that authorized above must be made with the express permission of AM General or the subcontractor whose copyrighted material is being used. This notice must be reproduced on all copies or portions thereof.

**WARNING****CARBON MONOXIDE (EXHAUST GAS) CAN KILL YOU**

Carbon monoxide is without color or smell, but can kill you. Breathing air with carbon monoxide produces symptoms of headache, dizziness, loss of muscular control, a sleepy feeling, and coma. Brain damage or death can result from heavy exposure. Carbon monoxide occurs in the exhaust fumes of fuel-burning heaters and internal combustion engines. Carbon monoxide can become dangerously concentrated under conditions of no air movement. Precautions must be followed to ensure crew safety when the personnel heater, main engine, or auxiliary engine of any vehicle is operated for any purpose.

1. DO NOT operate personnel heater or engine of vehicle in a closed place, unless the place has a lot of moving air.
2. DO NOT idle engine for long periods without ventilator blower operating.
3. DO NOT drive any vehicle with inspection plates, cover plates, or engine compartment doors removed, unless necessary for maintenance purposes.
4. BE ALERT at all times during vehicle operation for exhaust odors and exposure symptoms. If either is present, IMMEDIATELY VENTILATE personnel compartments. If symptoms persist, remove affected crew to fresh air; keep warm; DO NOT PERMIT PHYSICAL EXERCISE; if necessary, give artificial respiration.

FOR ARTIFICIAL RESPIRATION, REFER TO FM21-11.

5. BE AWARE: the field protective mask for chemical-biological-radiological (CBR) protection will not protect you from carbon monoxide poisoning.

THE BEST DEFENSE AGAINST CARBON MONOXIDE POISONING IS GOOD VENTILATION.

**WARNING**

Whenever hood is raised, insert the S-shaped safety hook through the two matching holes in the prop channels to prevent the hood from falling accidentally.

**WARNING**

Let radiator cool before removing cap. Remove radiator cap in two steps. First, place a thick cloth over the cap and slowly rotate cap counterclockwise to its first stop; pause, and let pressure escape from cooling system. Then rotate cap further counterclockwise until you can remove it. Failure to follow this procedure can result in serious burns.

**WARNING**

Do not smoke, have open flames, or make sparks around the batteries, especially if the caps (if so equipped) are off. Battery gases can explode and cause injury.

**WARNING**

Particles blown by compressed air are hazardous. Always direct air stream away from the user and other persons in the area. User must wear a safety eyeshield when using compressed air in cleaning.

**WARNING**

Improper cleaning methods and use of unauthorized cleaning solvents could injure personnel and damage equipment. See TM 9-247 for proper cleaning methods and authorized solvents.



**WARNING**

Compressed air used for cleaning purposes will not exceed 30 psi. Use only with effective chip guarding and personnel protective equipment (goggles/shield, gloves, etc.).

**WARNING**

Ether is highly explosive. Dispose of ether cylinders properly. Be alert for the strong odor of spilled ether. Guard against flame or sparks in work area when servicing ether cylinder.

**WARNING**

During normal operation, the exhaust pipes and muffler can become very hot. Be careful not to touch these components with your bare hands. Do not allow your body to come in contact with the hot pipes or muffler. Exhaust system components may be hot enough to cause serious burns.

**WARNING**

Cooling system components become hot during operation. To avoid personal injury, do not service cooling system components until cooling system has cooled down.

**WARNING**

Always remove negative battery ground cables first and install them last to avoid sparks that can cause an explosion. Failure to follow this precaution may result in serious injury to you and other personnel.

**WARNING**

Transmission oil is hot. Use care when draining transmission oil to prevent personal injury.

**WARNING**

Never work on air system components without first draining air pressure. Failure to follow this precaution can result in serious injury.

**d**

ORGANIZATIONAL MAINTENANCE MANUAL

TRUCK TRACTOR, LINE HAUL,  
50,000 GVWR, 6 X 4, M915A1

REPORTING ERRORS AND RECOMMENDING IMPROVEMENTS

You can help improve this manual. If you find any mistakes or if you know of a way to improve the procedures, please let us know. Mail your letter, DA Form 2028 (Recommended Changes to Publications and Blank Forms), or DA Form 2028-2 located in the back of this manual directly to Commander, U.S. Army Tank-Automotive Command, ATTN: DRSTA-MB, Warren, MI 48090. A reply will be furnished to you.

VOLUME 2 OF 3

	Page
Section VI. ELECTRICAL SYSTEM .....	3-384
3-68. General.....	3-384
3-69. Task Summary .....	3-384
3-70. Alternator and Bracket Replacement .....	3-396
3-71. Alternator Drive Belts Replacement .....	3-406
3-72. Starter Motor and Solenoid Replacement .....	3-412
3-73. Left-Hand Instrument Panel Gage Replacement.....	3-420
3-74. Ignition Switch Replacement.....	3-426
3-75. Pushbutton Starter Switch Replacement.....	3-430
3-76. Ether Start Switch Replacement .....	3-436
3-77. Pushbutton Clearance Lamp Switch Replacement.....	3-440
3-78. Headlamp Switch Replacement .....	3-446
3-79. Blackout Toggle Switch Replacement.....	3-452
3-80. Turn Signal Switch Replacement .....	3-458
3-81. Heater Fan Switch Replacement.....	3-468
3-82. Headlamp Dimmer Switch Replacement .....	3-474
3-83. Cigar Lighter Replacement.....	3-478

Section VI.	ELECTRICAL SYSTEM (Continued)	Page
	3-84. Low Air Pressure Lamp Replacement.....	3-482
	3-85. Ether Lamp and Clearance Lamp Replacement .....	3-486
	3-86. Wiper Lamp and Washer Lamp Replacement .....	3-490
	3-87. Warning and Indicator Lamps Replacement .....	3-496
	3-88. Three Position Engine Retarder Switch Replacement.....	3-504
	3-89. Engine Retarder Foot Switch Replacement .....	3-510
	3-90. Fuel Pump Engine Retarder Switch Replacement.....	3-516
	3-91. Headlamp Assembly Replacement .....	3-524
	3-92. Turn Signal and Marker Lamp Replacement .....	3-532
	3-93. Cab Clearance Lamp Assembly Replacement .....	3-540
	3-94. Blackout Marker Lamp Assembly Replacement .....	3-546
	3-95. Blackout Headlamp Assembly Replacement .....	3-554
	3-96. Stoplamp-Taillamp Assembly Replacement .....	3-562
	3-97. Blackout Taillamp Assembly Replacement .....	3-572
	3-98. Dome Lamp and Switch Replacement.....	3-582
	3-99. Map Lamp and Switch Replacement .....	3-588
	3-100. Hot Engine Temperature Switch Replacement .....	3-592
	3-101. Water Temperature Sending Unit Replacement .....	3-598
	3-102. Oil Pressure Sending Unit Replacement.....	3-602
	3-103. Transmission Temperature Sending Unit Replacement.....	3-606
	3-104. Low Oil Pressure Sending Unit Replacement .....	3-610
	3-105. Fuel Level Sending Unit Replacement.....	3-614
	3-106. Neutral Safety Switch and Reverse Switch Replacement.....	3-618
	3-107. Differential Lock Pressure Switch Replacement.....	3-626
	3-108. Park Brake Pressure Switch Replacement .....	3-634
	3-109. Low Air Pressure Switch Replacement .....	3-640
	3-110. Low Air Pressure Buzzer Replacement.....	3-644
	3-111. Turn Signal Flasher Replacement.....	3-648
	3-112. Instrument Panel Relays Replacement.....	3-652
	3-113. Instrument Panel 24 Volt Relay Replacement.....	3-656
	3-114. Manual Reset Circuit Breaker and Mounting Bracket Replacement .....	3-660
	3-115. Starter Relay Replacement .....	3-666
	3-116. Starting Circuit Diode Replacement .....	3-670
	3-117. Horn Replacement .....	3-674
	3-118. Horn Button Replacement.....	3-678
	3-119. Battery Charging.....	3-684
	3-120. Battery Power Disconnect and Connect Procedure .....	3-694
	3-121. Battery Replacement.....	3-702
	3-122. Battery Box Replacement.....	3-708

	Page
Section VI.	ELECTRICAL SYSTEM (Continued)
	3-123. Battery Box Latch Replacement.....3-712
	3-124. Battery Cable Replacement .....3-716
	3-125. Slave Start Receptacle Replacement.....3-736
	3-126. Wiring Harness Replacement .....3-740
	3-127. Wiring Harness Repair .....3-742
	3-128. Ground Strap and Cables Replacement .....3-766
	3-129. Blackout Marker Lamp and Headlamp Cable Replacement.....3-772
	3-130. Trailer Receptacle Bracket Replacement.....3-778
	3-131. STE/ICE Connector Bracket Replacement .....3-784
	3-132. Utility Outlet Receptacle Replacement.....3-788
Section VII.	TRANSMISSION .....3-792
	3-133. General.....3-792
	3-134. Task Summary .....3-792
	3-135. Transmission Servicing .....3-794
	3-136. Oil Level Gage and Tube Replacement .....3-806
	3-137. Shifter Control Replacement .....3-812
	3-138. Shifter Control Cable Replacement.....3-820
	3-139. Shifter Control Mounting Bracket Replacement.....3-832
	3-140. Modulator Control Replacement.....3-838
	3-141. Lines and Fittings Replacement.....3-846
Section VIII.	PROPELLER SHAFTS AND UNIVERSAL JOINTS .....3-856
	3-142. General.....3-856
	3-143. Task Summary .....3-856
	3-144. Primary Propeller Shaft and Universal Joints Replacement .....3-858
	3-145. Interaxle Propeller Shaft and Universal Joints Replacement .....3-868
Section IX.	FRONT AXLE.....3-876
	3-146. General.....3-876
	3-147. Task Summary .....3-876
	3-148. Steering Arm Replacement .....3-878
	3-149. Steering Knuckle Assembly Replacement .....3-882
	3-150. Tie Rod Arm Replacement.....3-892
Section XI.	BRAKE SYSTEM.....3-908
	3-155. General.....3-908
	3-156. Task Summary .....3-908
	3-157. Slack Adjuster Replacement .....3-916
	3-158. Brake Assembly Replacement .....3-922
	3-159. Brake Shoe Replacement .....3-928
	3-160. Camshaft and Camshaft Bracket Replacement.....3-934

Section XI.	BRAKE SYSTEM (Continued)	Page
	3-161. Spider and Anchor Pin Replacement .....	3-940
	3-162. Dust Shield Replacement.....	3-944
	3-163. Air Lines and Fittings Replacement.....	3-948
	3-164. Front Axle and Rear-Rear Axle Brake Chamber Replacement.....	3-950
	3-165. Front Axle and Rear-Rear Axle Brake Chamber Repair .....	3-956
	3-166. Forward-Rear Axle Brake Chamber Replacement.....	3-962
	3-167. Front External Air Couplings Replacement .....	3-968
	3-168. Supply Reservoir Replacement.....	3-976
	3-169. Primary Reservoir Replacement .....	3-984
	3-170. Secondary Reservoir Replacement.....	3-990
	3-171. Park Brake Valve Replacement .....	3-996
	3-172. Park Brake Valve Repair .....	3-1002
	3-173. Trailer Hand Brake Valve Replacement .....	3-1010
	3-174. Brake Treadle Valve Replacement .....	3-1020
	3-175. Trailer Supply Valve Replacement.....	3-1030
	3-176. Trailer Supply Valve Repair.....	3-1036
	3-177. Relay Valve Replacement.....	3-1044
	3-178. Forward-Rear Axle Quick Release Valve Replacement.....	3-1052
	3-179. Rear-Rear Axle Quick Release Valve Replacement.....	3-1058
	3-180. Mountable Tee Replacement .....	3-1064
	3-181. Front Axle Ratio Valve Replacement .....	3-1072
	3-182. Double Check and Quick Release Valve Replacement.....	3-1078
	3-183. Double Check and Stoplamp Valve Replacement.....	3-1084
	3-184. Firewall Double Check Valve Replacement .....	3-1092
	3-185. Secondary Reservoir Double Check Valve Replacement.....	3-1098
	3-186. Supply Reservoir Safety Valve Replacement.....	3-1104
	3-187. Secondary Reservoir Check Valve Replacement.....	3-1108
	3-188. Primary and Secondary Reservoir Draincock Replacement.....	3-1112
	3-189. Primary Reservoir Check Valve Replacement.....	3-1116
	3-190. Supply Reservoir Drain Valve Replacement .....	3-1120
	3-191. Supply Reservoir Single Check Valve Replacement.....	3-1124
	3-192. Tractor Protection Valve Replacement .....	3-1130

Section XI.

BRAKE SYSTEM (Continued)

3-193. Brake Pedal Double Check Valve Replacement.....	3-1138
3-194. Fifth Wheel Toggle Valve Replacement.....	3-1144
3-195. Differential Toggle Valve Replacement.....	3-1152
3-196. Trailer Couplings, Brackets, and Hose Replacement.....	3-1160
3-197. Hose Tender Replacement .....	3-1168
3-198. Air Dryer Replacement .....	3-1172
3-199. Air Dryer Repair.....	3-1180
3-200. Air Dryer Dehydrate Cartridge Replacement.....	3-1194

**Section VI. ELECTRICAL SYSTEM**

**3-68. GENERAL.**

This section provides procedures authorized at the organizational maintenance level to replace electrical system components. To find a specific procedure contained in this section, see the task summary below.

**3-69. TASK SUMMARY.**

**INITIAL SETUP**

APPLICABLE CONFIGURATIONS

All

EQUIPMENT CONDITION

PARAGRAPH

(Refer to specific paragraph for this information).

CONDITION DESCRIPTION

TEST EQUIPMENT

None.

SPECIAL TOOLS

None.

MATERIALS/PARTS (P/N)

Sealant, pipe Item 24,	Alternator drive belt, Appendix C matched pair (11288) 9429178.
Compound, thread locking Item 10, Appendix C	Gasket (19207) 11664431.
Putty, linseed oil Item 21, Appendix C	Gasket (19207) 11664480.
Sealer, nonhardening Item 25, Appendix C	Rope, nylon, 10 ft.
Grease, automotive and artillery (GAA) Item 7, Appendix C	Tie, cable (06383) SST4S.
Solvent, drycleaning, SD-2 Item 29, Appendix C	Seal, O-ring (15434) 3030808.
Thread sealant, liquid Item 33, Appendix C	Rivet, blind, 3/16-inch (2) (05693) SSP-62.
Tape, thread sealing Item 32, Appendix C	Pin, cotter (24617) 137137.
Rags, wiping Item 22, Appendix C	Gasket (98440) 2013.
Solution, soap Item 28, Appendix C	Pin, cotter (24617) 453689.
Sodium bicarbonate (baking soda) Item 27, Appendix C	Rivet (2) (11815) SSPQ-41.
Black acidproof paint Item 4, Appendix C.	



**ELECTRICAL SYSTEM.**

**3-69. TASK SUMMARY (Continued).**

INITIAL SETUP (Continued)

PERSONNEL REQUIRED  
Two (MOS-63S5).

SPECIAL ENVIRONMENTAL CONDITIONS  
Vehicle on level ground.

REFERENCES (TM)  
TM 9-2320-283-10.  
TM 9-2320-283-20P.

GENERAL SAFETY INSTRUCTIONS  
Engine off.  
Transmission in neutral.  
Park brake set.  
Starter assembly is heavy; use caution when removing.  
Engine coolant at room temperature.  
Wear safety goggles.

TROUBLESHOOTING REFERENCES  
Paragraph 2-11.

**LIST OF TASKS**

<b>Task No.</b>	<b>Task</b>	<b>Task Ref</b>	<b>Troubleshooting Ref No. (Page)</b>
1	Alternator and Bracket Replacement a. Removal. b. Installation. c. Operational Check.	3-70 3-70a 3-70b 3-70c	2-11
2	Alternator Drive Belts Replacement a. Removal. b. Installation. c. Adjustment.	3-71 3-71a 3-71b 3-71c	2-11
3	Starter Motor and Solenoid Replacement a. Removal. b. Installation. c. Operational Check.	3-72 3-72a 3-72b 3-72c	2-11
4	Left-Hand Instrument Panel Gage Replacement a. Removal. b. Installation. c. Operational Check.	3-73 3-73a 3-73b 3-73c	2-11
5	Ignition Switch Replacement a. Removal. b. Installation. c. Operational Check.	3-74 3-74a 3-74b 3-74c	2-11

## ELECTRICAL SYSTEM.

## 3-69. TASK SUMMARY (Continued).

## LIST OF TASKS

Task No.	Task	Task Ref	Troubleshooting Ref No. (Page)
6	Pushbutton Starter Switch Replacement	3-75	2-11
	a. Removal.	3-75a	
	b. Installation.	3-75b	
	c. Operational Check.	3-75c	
7	Ether Start Switch Replacement	3-76	2-11
	a. Removal.	3-76a	
	b. Installation.	3-76b	
	c. Operational Check.	3-76c	
8	Pushbutton Clearance Lamp Switch Replacement	3-77	2-11
	a. Removal.	3-77a	
	b. Installation.	3-77b	
	c. Operational Check.	3-77c	
9	Headlamp Switch Replacement	3-78	2-11
	a. Removal.	3-78a	
	b. Installation.	3-78b	
	c. Operational Check.	3-78c	
10	Blackout Toggle Switch Replacement	3-79	2-11
	a. Removal.	3-79a	
	b. Replacement.	3-79b	
	c. Operational Check.	3-79c	
11	Turn Signal Switch Replacement	3-80	2-11
	a. Removal.	3-80a	
	b. Disassembly.	3-80b	
	c. Assembly	3-80c	
	d. Installation.	3-80d	
	e. Operational Check.	3-80e	
12	Heater Fan Switch Replacement	3-81	2-11
	a. Removal.	3-81a	
	b. Installation.	3-81b	
	c. Operational Check.	3-81c	

## ELECTRICAL SYSTEM.

## 3-69. TASK SUMMARY (Continued).

## LIST OF TASKS

Task No.	Task	Task Ref	Troubleshooting Ref No. (Page)
13	Headlamp Dimmer Switch Replacement	3-82	2-11
	a. Removal.	3-82a	
	b. Installation.	3-82b	
	c. Operational Check.	3-82c	
14	Cigar Lighter Replacement	3-83	2-11
	a. Removal.	3-83a	
	b. Installation.	3-83b	
	c. Operational Check.	3-83c	
15	Low Air Pressure Lamp Replacement	3-84	2-11
	a. Removal.	3-84a	
	b. Installation.	3-84b	
	c. Operational Check.	3-84c	
16	Ether Lamp and Clearance Lamp Replacement	3-85	2-11
	a. Removal.	3-85a	
	b. Installation.	3-85b	
	c. Operational Check.	3-85c	
17	Wiper Lamp and Washer Lamp Replacement	3-86	2-11
	a. Removal.	3-86a	
	b. Installation.	3-86b	
	c. Operational Check.	3-86c	
18	Warning and Indicator Lamps Replacement	3-87	2-11
	a. Marker Lamp Removal.	3-87a	
	b. Marker Lamp Installation.	3-87b	
	c. Tube Assembly and Lenses Removal.	3-87c	
	d. Tube Assembly and Lenses Installation.	3-87d	
	e. Operational Check.	3-87e	
19	Three Position Engine Retarder Switch Replacement	3-88	2-11
	a. Removal.	3-88a	
	b. Installation.	3-88b	
	c. Operational Check.	3-88c	

ELECTRICAL SYSTEM.

3-69. TASK SUMMARY (Continued).

LIST OF TASKS

Task No.	Task	Task Ref	Troubleshooting Ref No. (Page)
20	Engine Retarder Foot Switch Replacement a. Removal. b. Installation. c. Operational Check.	3-89 3-89a 3-89b 3-89c	2-11
21	Fuel Pump Engine Retarder Switch Replacement a. Removal. b. Disassembly. c. Assembly. d. Installation. e. Operational Check.	3-90 3-90a 3-90b 3-90c 3-90d 3-90e	2-11
22	Headlamp Assembly Replacement a. Removal. b. Installation. c. Operational Check.	3-91 3-91a 3-91b 3-91c	2-11
23	Turn Signal and Marker Lamp Replacement a. Turn Signal and Marker Lamp Bulb Removal. b. Turn Signal and Marker Lamp Bulb Installation. c. Turn Signal and Marker Lamp Assembly Removal. d. Turn Signal and Marker Lamp Assembly Installation. e. Operational Check.	3-92 3-92a 3-92b 3-92c 3-92d 3-92e	2-11
24	Cab Clearance Lamp Assembly Replacement a. Cab Clearance Lamp Removal. b. Cab Clearance Lamp Installation. c. Cab Clearance Lamp Assembly Removal. d. Cab Clearance Lamp Assembly Installation. e. Operational Check.	3-93 3-93a 3-93b 3-93c 3-93d 3-93e	2-11
25	Blackout Marker Lamp Assembly Replacement a. Blackout Marker Lamp Removal. b. Blackout Marker Lamp Installation.	3-94 3-94a 3-94b	2-11
<b>3-388</b>			

ELECTRICAL SYSTEM.

3-69. TASK SUMMARY (Continued).

LIST OF TASKS

Task No.	Task	Task Ref	Troubleshooting Ref No. (Page)
25	Blackout Marker Lamp Assembly Replacement (Continued) c. Blackout Marker Lamp Assembly Removal. d. Blackout Marker Lamp Assembly Disassembly. e. Blackout Marker Lamp Assembly Reassembly. f. Blackout Marker Lamp Assembly Installation. g. Blackout Marker Lamp Assembly Operational Check.	3-94c 3-94d 3-94e 3-94f 3-94g	2-11
26	Blackout Headlamp Assembly Replacement a. Blackout Headlamp Removal. b. Blackout Headlamp Installation. c. Blackout Headlamp Assembly Removal. d. Blackout Headlamp Assembly Disassembly. e. Blackout Headlamp Assembly Reassembly. f. Blackout Headlamp Assembly Installation. g. Blackout Headlamp Assembly Operational Check.	3-95 3-95a 3-95b 3-95c 3-95d 3-95e 3-95f 3-95g	2-11
27	Stoplamp-Taillamp Assembly Replacement a. Stoplamp-Taillamp-Backup Lamp Removal. b. Stoplamp-Taillamp-Backup Lamp Installation. c. Stoplamp-Taillamp Assembly Removal. d. Stoplamp-Taillamp Assembly Disassembly. e. Stoplamp-Taillamp Assembly Reassembly. f. Stoplamp-Taillamp Assembly Installation. g. Stoplamp-Taillamp Operational Check.	3-96 3-96a 3-96b 3-96c 3-96d 3-96e 3-96f 3-96g	2-11

ELECTRICAL SYSTEM.

3-69. TASK SUMMARY (Continued).

LIST OF TASKS

Task No.	Task	Task Ref	Troubleshooting Ref No. (Page)
28	Blackout Taillamp Assembly Replacement a. Blackout Taillamp Removal. b. Blackout Taillamp Installation. c. Blackout Taillamp Assembly Removal. d. Blackout Taillamp Assembly Disassembly. e. Blackout Taillamp Assembly Reassembly. f. Blackout Taillamp Assembly Installation. g. Blackout Taillamp Assembly Operational Check.	3-97 3-97a 3-97b 3-97c 3-97d 3-97e 3-97f 3-97g	2-11
29	Dome Lamp and Switch Replacement a. Dome Lamp Removal. b. Dome Lamp Installation. c. Dome Lamp and Switch Assembly Removal. d. Dome Lamp and Switch Assembly Installation. e. Dome Lamp and Switch Assembly Operational Check.	3-98 3-98a 3-98b 3-98c 3-98d 3-98e	2-11
30	Map Lamp and Switch Replacement a. Removal. b. Installation.	3-99 3-99a 3-99b	2-11
31	Hot Engine Temperature Switch Replacement a. Removal. b. Installation. c. Operational Check.	3-100 3-100a 3-100b 3-100c	2-11
32	Water Temperature Sending Unit Replacement a. Removal. b. Installation.	3-101 3-101a 3-101b	2-11

## ELECTRICAL SYSTEM.

## 3-69. TASK SUMMARY (Continued).

## LIST OF TASKS

Task No.	Task	Task Ref	Troubleshooting Ref No. (Page)
33	Oil Pressure Sending Unit Replacement a. Removal. b. Installation.	3-102 3-102a 3-102b	2-11
34	Transmission Temperature Sending Unit Replacement a. Removal. b. Installation.	3-103 3-103a 3-103b	2-11
35	Low Oil Pressure Sending Unit Replacement a. Removal. b. Installation.	3-104 3-104a 3-104b	2-11
36	Fuel Level Sending Unit Replacement a. Removal. b. Installation.	3-105 3-105a 3-105b	2-11
37	Neutral Safety Switch and Reverse Switch Replacement a. Removal. b. Installation. c. Operational Check.	3-106 3-106a 3-106b 3-106c	2-11
38	Differential Lock Pressure Switch Replacement a. Removal. b. Installation. c. Operational Check.	3-107 3-107a 3-107b 3-107c	2-11
39	Park Brake Pressure Switch Replacement a. Removal. b. Installation. c. Operational Check.	3-108 3-108a 3-108b 3-108c	2-11
40	Low Air Pressure Switch Replacement a. Removal. b. Cleaning and Inspection. c. Installation.	3-109 3-109a 3-109b 3-109c	2-11

ELECTRICAL SYSTEM.

3-69. TASK SUMMARY (Continued).

LIST OF TASKS

Task No.	Task	Task Ref	Troubleshooting Ref No. (Page)
41	Low Air Pressure Buzzer Replacement a. Removal. b. Cleaning and Inspection. c. Installation.	3-110 3-110a 3-110b 3-110c	2-11
42	Turn Signal Flasher Replacement a. Removal. b. Cleaning and Inspection. c. Installation.	3-111 3-111a 3-111b 3-111c	2-11
43	Instrument Panel Relays Replacement a. Removal. b. Cleaning and Inspection. c. Installation.	3-112 3-112a 3-112b 3-112c	2-11
44	Instrument Panel 24-Volt Relay Replacement a. Removal. b. Cleaning and Inspection. c. Installation.	3-113 3-113a 3-113b 3-113c	2-11
45	Manual Reset Circuit Breaker and Mounting Bracket Replacement a. Mounting Bracket Removal. b. Circuit Breaker Removal. c. Circuit Breaker Installation. d. Mounting Bracket Installation.	3-114 3-114a 3-114b 3-114c 3-114d	2-11
46	Starter Relay Replacement a. Removal. b. Installation.	3-115 3-115a 3-115b	2-11
47	Starting Circuit Diode Replacement a. Removal. b. Installation.	3-116 3-116a 3-116b	2-11
48	Horn Replacement a. Removal. b. Cleaning. c. Inspection. d. Installation. 3-117d	3-117 3-117a 3-117b 3-117c	2-11



## ELECTRICAL SYSTEM.

## 3-69. TASK SUMMARY (Continued).

## LIST OF TASKS

Task No.	Task	Task Ref	Troubleshooting Ref No. (Page)
49	Horn Button Replacement a. Removal. b. Cleaning and Inspection. c. Installation.	3-118 3-118a 3-118b 3-118c	2-11
50	Battery Charging a. Connect Charger. b. Charge Battery. c. Disconnect Charger.	3-119 3-119a 3-119b 3-119c	2-11
51	Battery Power Disconnect and Connect Procedure a. Disconnect. b. Cleaning. c. Inspection. d. Connect.	3-120 3-120a 3-120b 3-120c 3-120d	2-11
52	Battery Replacement a. Removal. b. Cleaning. c. Inspection. d. Installation.	3-121 3-121a 3-121b 3-121c 3-121d	2-11
53	Battery Box Replacement a. Removal. b. Cleaning. c. Installation.	3-122 3-122a 3-122b 3-122c	2-11
54	Battery Box Latch Replacement a. Removal. b. Installation.	3-123 3-123a 3-123b	2-11
55	Battery Cable Replacement a. Battery Cable Removal. b. Battery Cable Installation. c. Positive Battery Power Cable (Battery to Starter Motor) Replacement.	3-124 3-124a 3-124b 3-124c	2-11

ELECTRICAL SYSTEM.

3-69. TASK SUMMARY (Continued).

LIST OF TASKS

Task No.	Task	Task Ref	Troubleshooting Ref No. (Page)
55	Battery Cable Replacement (Continued) d. Negative Battery Power Cable (Battery-to-Starter Motor) Replacement. e. Positive Battery Power Cable (Battery-to-Receptacle) Replacement. f. Negative Battery Power Cable (Battery-to-Receptacle) Replacement. g. Positive Battery Power Cable (Battery A-to-Battery B) Replacement. h. Positive Battery Power Cable (Battery A-to-Battery C) Replacement. i. Positive Battery Power Cable (Battery C-to-Battery D) Replacement. j. Positive Battery Power Cable (Battery B-to-Battery D) Replacement. k. Negative Battery Power Cable (Battery D-to-Battery C) Replacement. l. Cleaning and Inspecting Cables.	3-124d 3-124e 3-124f 3-124g 3-124h 3-124i 3-124j 3-124k 3-124l	
56	Slave Start Receptacle Replacement a. Removal. b. Installation.	3-125 3-125a 3-125b	2-11
57	Wiring Harness Replacement	3-126	2-11
58	Wiring Harness Repair a. STE/ICE Connector Receptacle Repair. b. Circular Connector Plug Repair. c. Circular Connector Receptacle Repair. d. Relay Connector Receptacle Repair. e. 24-Volt Connector Receptacle Repair.	3-127 3-127a 3-127b 3-127c 3-127d 3-127e	2-11

## ELECTRICAL SYSTEM.

## 3-69. TASK SUMMARY (Continued).

## LIST OF TASKS

Task No.	Task	Task Ref	Troubleshooting Ref No. (Page)
58	Wiring Harness Repair (Continued)	2-11	
	f. 12-Volt Connector Receptacle Repair.	3-127f	
	g. Plastic Connector Receptacle or Plug Repair.	3-127g	
	h. Wire Replacement.	3-127h	
59	Ground Strap and Cables Replacement	3-128	2-11
	a. Starter Ground Strap Removal.	3-128a	
	b. Starter Ground Strap Installation.	3-128b	
	c. Engine to Frame Ground Cable Removal.	3-128c	
	d. Engine to Frame Ground Cable Installation.	3-128d	
	e. Cab to Frame Ground Cable Removal.	3-128e	
	f. Cab to Frame Ground Cable Installation.	3-128f	
60	Blackout Marker Lamp and Headlamp Cable Replacement	3-129	2-11
	a. Access Cable.	3-129a	
	b. Marker Lamp Cable Removal.	3-129b	
	c. Headlamp Cable Removal.	3-129c	
	d. Headlamp Cable Installation.	3-129d	
	e. Marker Lamp Cable Installation.	3-129e	
	f. Headlamp Assembly Installation.	3-129f	
61	Trailer Receptacle Bracket Replacement	3-130	2-11
	a. Removal of Cab Mounted Bracket and Cover.	3-130a	
	b. Installation of Cab Mounted Bracket and Cover.	3-130b	
	c. Removal of Rear Cover.	3-130c	
	d. Installation of Rear Cover.	3-130d	
62	STE/ICE Connector Bracket Replacement	3-131	2-11
	a. Removal.	3-131a	
	b. Installation.	3-131b	
63	Utility Outlet Receptacle Replacement	3-132	2-11
	a. Removal.	3-132a	
	b. Installation.	3-132b	

**ELECTRICAL SYSTEM.**

**3-70. ALTERNATOR AND BRACKET REPLACEMENT.**

<b>This task covers:</b>		
<b>a. Removal</b>	<b>b. Installation</b>	<b>c. Operational Check</b>
<b>INITIAL SETUP:</b>		
a. Removal.		
b. Installation.		
c. Operational Check.		
<b>INITIAL SETUP</b>		
<b>APPLICABLE CONFIGURATIONS</b> All. 3-120.	<b>EQUIPMENT CONDITION PARAGRAPH</b>	<b>CONDITION DESCRIPTION</b> Battery power disconnected.
<b>TEST EQUIPMENT</b> None.	3-52.	Radiator drained.
	3-32	Air cleaner inlet removed.
<b>SPECIAL TOOLS</b> None.		
<b>MATERIALS/PARTS (P/N)</b> Sealant, pipe Item 24, Appendix C.		
<b>PERSONNEL REQUIRED</b> One (MOS-63S).	<b>SPECIAL ENVIRONMENTAL CONDITIONS</b> Vehicle parked on level ground.	
<b>REFERENCES (TM)</b> TM 9-2320-283-10.	<b>GENERAL SAFETY INSTRUCTIONS</b> Engine off. Transmission in neutral. Park brake set.	
<b>TROUBLESHOOTING REFERENCES</b> Paragraph 2-11.		
<b>3-396</b>		

ELECTRICAL SYSTEM.

3-70. ALTERNATOR AND BRACKET REPLACEMENT (Continued).

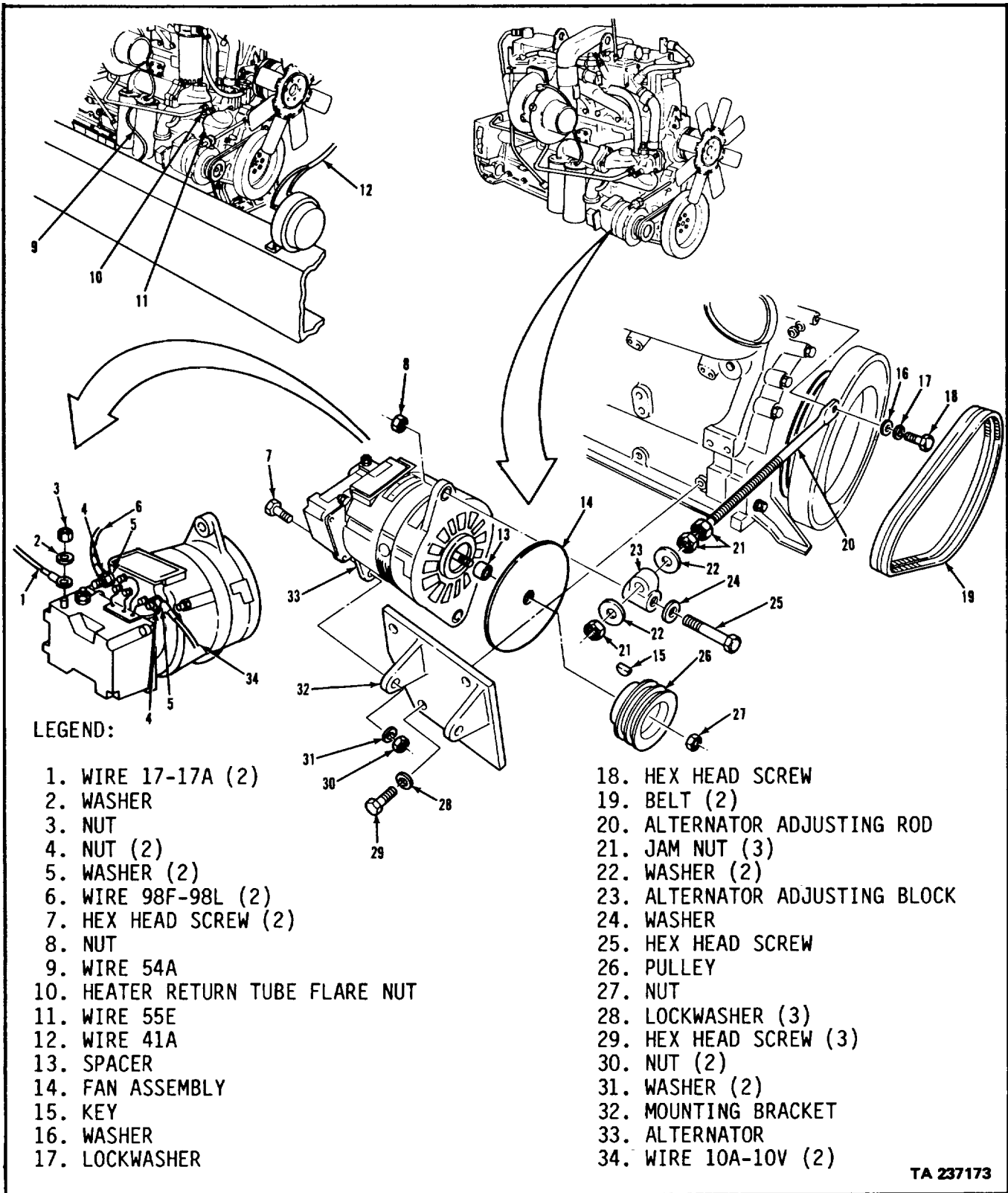

TA 237173

## ELECTRICAL SYSTEM.

## 3-70. ALTERNATOR AND BRACKET REPLACEMENT (Continued).

LOCATION / ITEM	ACTION	REMARKS
A. REMOVAL.		
1. Three wires (9), (11), and (12).	Remove. Position out of way.	Tag for identification.
2. Heater return tube and flare nut (10).	Loosen and remove item (10).	Raise and position out of way. Do not allow coolant to drip on alternator. Plug line if necessary.
3. Nut (3), washer (2), two nuts (4), and two washers (5).	Remove items (2), (3), and two items (4) and (5).	
4. Three wires (1), (6), and (34).	Remove.	Tag for identification.
5. Three jam nuts (21).	Loosen.	Release tension on items (33) and (19).
6. Hex head screw (25), nut (8), and washer (24).	Remove from item (23).	
7. Hex head screw (18), lockwasher (17), washer (16).	Remove items (18), (17), and (16).	Remove item (20). Check item (20) for damaged threads. Replace if bent.
8. Two nuts (30) and two hex head screws (7).	Loosen two item pairs (30) and (7).	Do not remove.
9. Alternator (33).	Move item (33) towards engine and remove two items (19).	
10. Two hex head screws (7), two washers (31), and two nuts (30).	Remove two items (7), (31), and (30) slowly while holding item (33) in place.	

ELECTRICAL SYSTEM.

3-70. ALTERNATOR AND BRACKET REPLACEMENT (Continued).

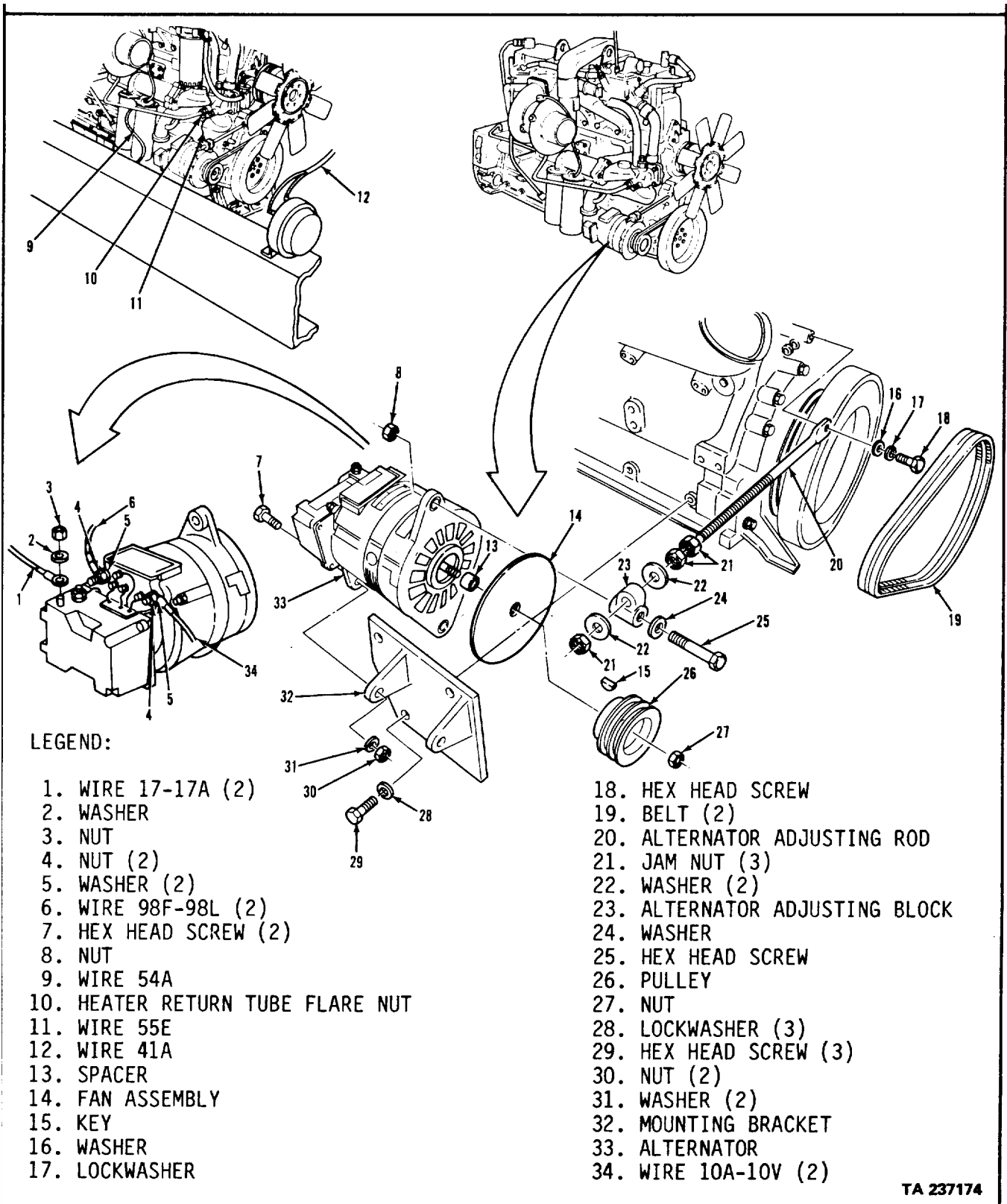

TA 237174

**ELECTRICAL SYSTEM.****3-70. ALTERNATOR AND BRACKET REPLACEMENT (Continued).**

LOCATION / ITEM	ACTION	REMARKS
A. REMOVAL (Continued).		
11. Alternator (33). rear to aid removal.	Remove item (33).	Tilt item (33) up from
12. Three screws (29) and three lock- washers (28).	Remove from item (32).  damaged.	Inspect item (32) for damage. Replace if
13. Nut (27), pulley (26), key (15), fan (14), and spacer (13).	Remove from item (33) shaft. (14) for damage. Replace if damaged.	Inspect items (26) and
B. INSTALLATION.		
14. Three lockwashers (28) and three screws (29).	Secure item (32) to side of engine.	
15. Spacer (13), fan (14), key (15), pulley (26), and nut (27).	Install on item (33) shaft.	Transfer parts if not damaged.
16. Alternator (33).	Aline and hold in place.	
17. Two hex head screws (7), two washers (31), and two nuts (30).	Install two items (7), (31), and (30), but do not tighten.	
18. Alternator adjust- ing rod (20).	Lower and aline with mounting holes on engine and item (33).	
19. Hex head screw (18), lockwasher (17), and washer (16).	Install items (18), (17), and (16) through mounting hole in item (20).	Do not tighten.
<b>3-400</b>		



ELECTRICAL SYSTEM

3-70. ALTERNATOR AND BRACKET REPLACEMENT (Continued).

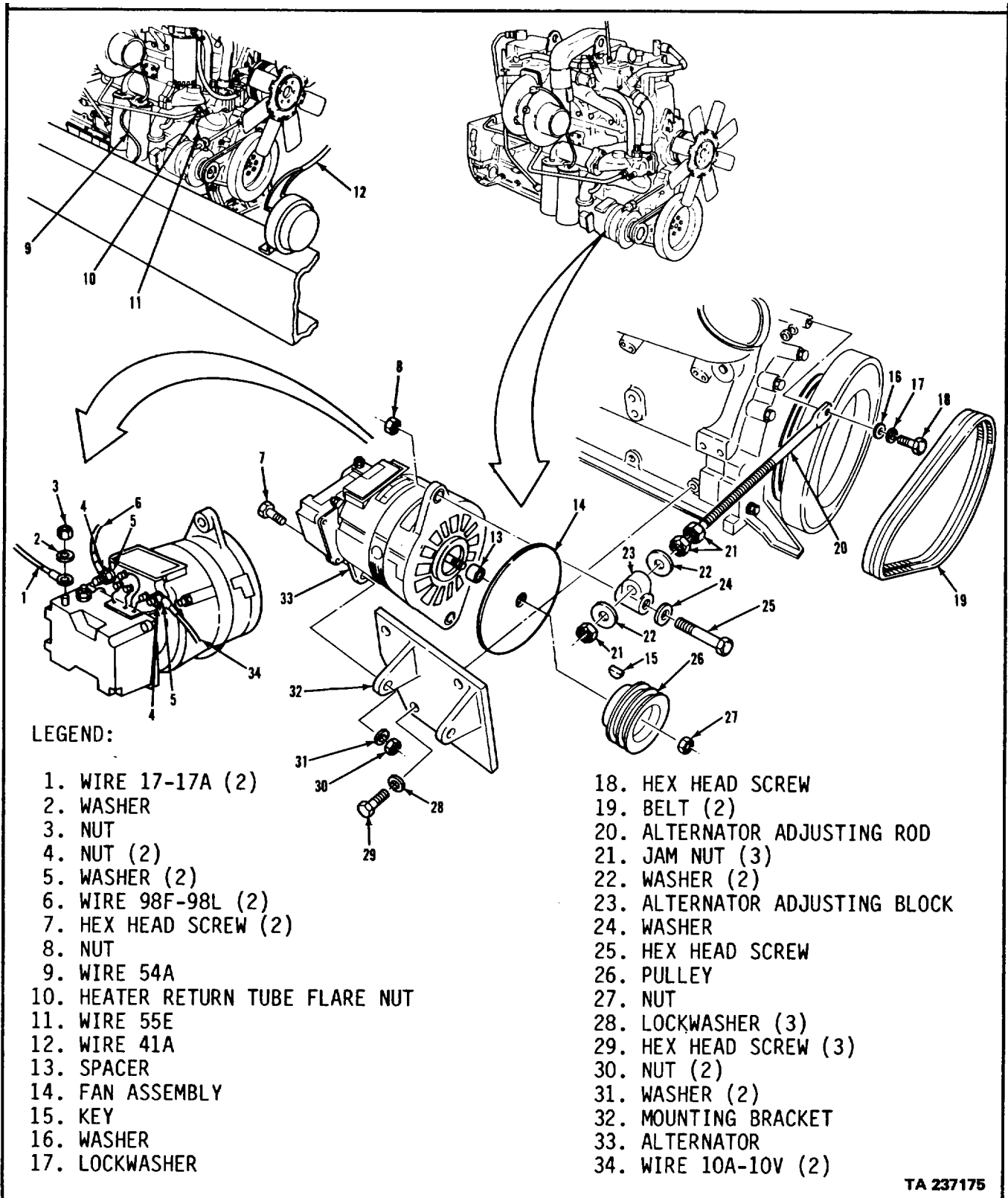

TA 237175

## ELECTRICAL SYSTEM.

## 3-70. ALTERNATOR AND BRACKET REPLACEMENT (Continued).

LOCATION / ITEM	ACTION	REMARKS
B. INSTALLATION (Continued).		
20. Alternator adjusting rod (20).	Aline item (20) with mounting hole on item (33).	
21. Hex head screw (25), washer (24), and nut (8).	Install items (25), (24), and (8), but do not tighten.	
22. Alternator (33). and replace two items (19).	Push item (33) towards engine	
23. Three jam nuts (21).	Tighten three items (21) against two items (22) until proper tension is applied to two items (19).	Refer to paragraph 3-71.
24. Hex head screw (25) and nut (8).	Torque item (25) to 30 lb-ft.	
25. Hex head screw (18).	Tighten item (18).	
26. Two hex head screws (7) and two nuts (20).	Torque two items (30) to 30 lb-ft.	
27. Wire (1), wire (6), and wire (34).	Install items (1), (6), and (34).	Use tags to aid in identification.
28. Nut (3), washer (2), two nuts (4), and two washer (5).	Install and tighten items (3), (2), and two items (4) and (5).	
29. Heater return tube flare nut (10).	Install item (10) and tighten.	Coat threads with pipe sealant.
<b>3-402</b>		

**ELECTRICAL SYSTEM.**

**3-70. ALTERNATOR AND BRACKET REPLACEMENT (Continued).**

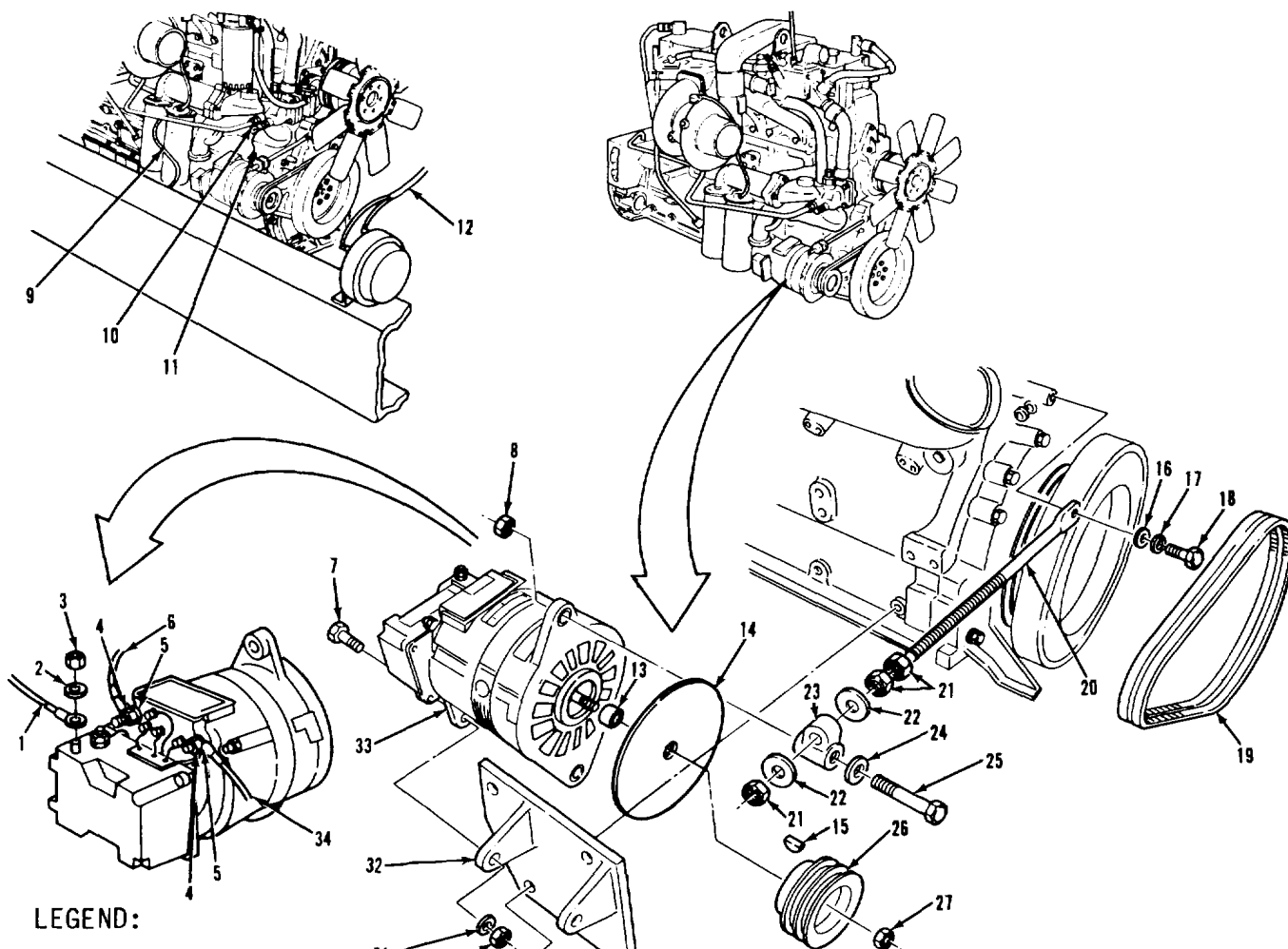

**LEGEND:**

- 1. WIRE 17-17A (2)
- 2. WASHER
- 3. NUT
- 4. NUT (2)
- 5. WASHER (2)
- 6. WIRE 98F-98L (2)
- 7. HEX HEAD SCREW (2)
- 8. NUT
- 9. WIRE 54A
- 10. HEATER RETURN TUBE FLARE NUT
- 11. WIRE 55E
- 12. WIRE 41A
- 13. SPACER
- 14. FAN ASSEMBLY
- 15. KEY
- 16. WASHER
- 17. LOCKWASHER

- 18. HEX HEAD SCREW
- 19. BELT (2)
- 20. ALTERNATOR ADJUSTING ROD
- 21. JAM NUT (3)
- 22. WASHER (2)
- 23. ALTERNATOR ADJUSTING BLOCK
- 24. WASHER
- 25. HEX HEAD SCREW
- 26. PULLEY
- 27. NUT
- 28. LOCKWASHER (3)
- 29. HEX HEAD SCREW (3)
- 30. NUT (2)
- 31. WASHER (2)
- 32. MOUNTING BRACKET
- 33. ALTERNATOR
- 34. WIRE 10A-10V (2)

TA 237176

**ELECTRICAL SYSTEM.**

**3-70. ALTERNATOR AND BRACKET REPLACEMENT (Continued).**

LOCATION/ITEM	ACTION	REMARKS
<b>B. INSTALLATION (Continued)</b>		
30. Three wires (9), (11), and (12)	Install items (9), (11), and (12)	Use tags to aid in identification.
31. Batteries	Connect	Refer to paragraph 3-120.
32. Radiator	Refill	Refer to paragraph 3-52.
33. Air cleaner inlet	Install	Refer to paragraph 3-32.
<b>C. OPERATIONAL CHECK.</b>		
34. Engine reads normal	Start up	Verify voltmeter Refer to TM 9-2320-283-10.
<p><b>NOTE</b> Follow-on maintenance action required: None.</p>		
<p><b>3-404</b></p>		

ELECTRICAL SYSTEM.

3-70. ALTERNATOR AND BRACKET REPLACEMENT (Continued).

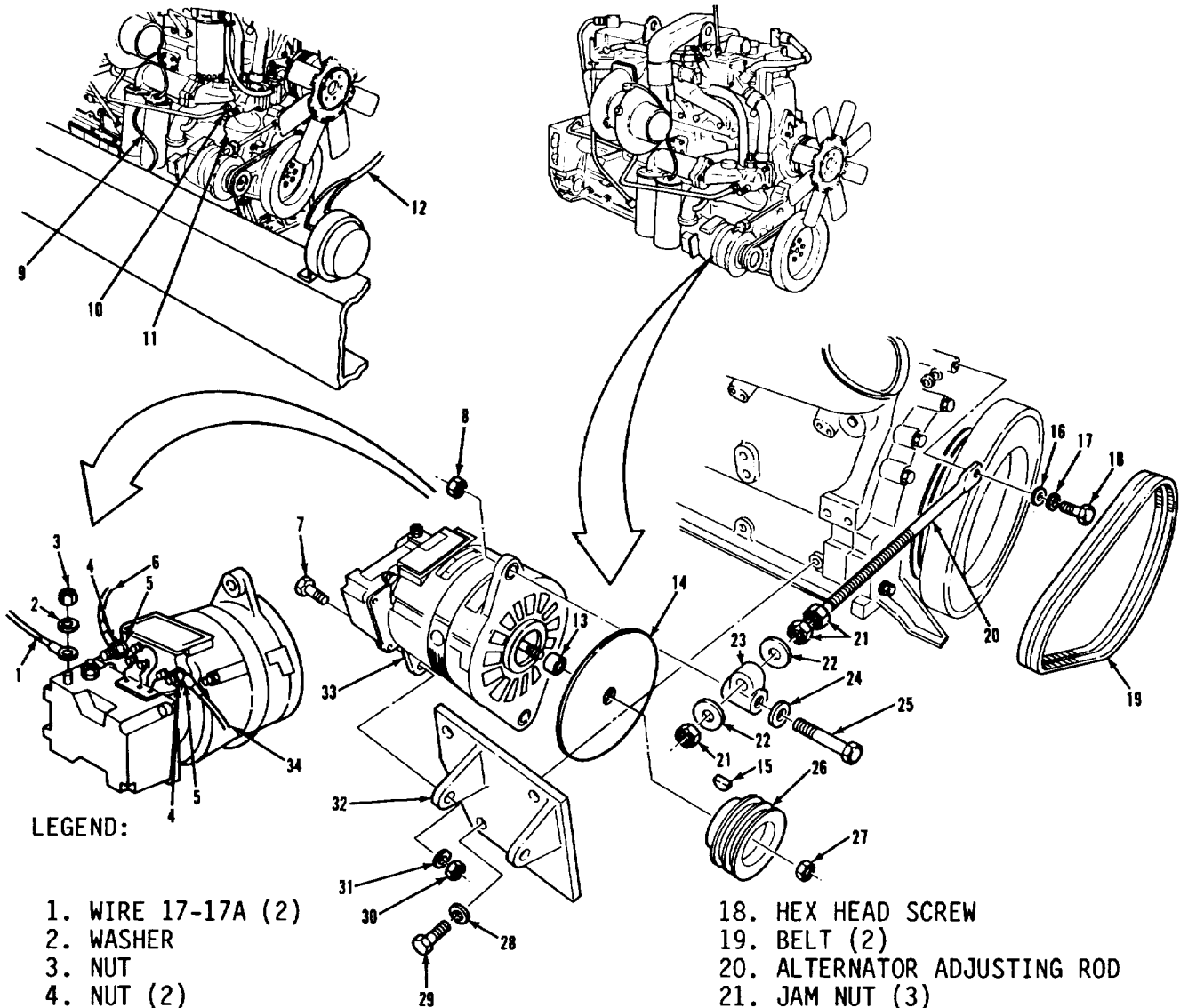

LEGEND:

- 1. WIRE 17-17A (2)
- 2. WASHER
- 3. NUT
- 4. NUT (2)
- 5. WASHER (2)
- 6. WIRE 98F-98L (2)
- 7. HEX HEAD SCREW (2)
- 8. NUT
- 9. WIRE 54A
- 10. HEATER RETURN TUBE FLARE NUT
- 11. WIRE 55E
- 12. WIRE 41A
- 13. SPACER
- 14. FAN ASSEMBLY
- 15. KEY
- 16. WASHER
- 17. LOCKWASHER

- 18. HEX HEAD SCREW
- 19. BELT (2)
- 20. ALTERNATOR ADJUSTING ROD
- 21. JAM NUT (3)
- 22. WASHER (2)
- 23. ALTERNATOR ADJUSTING BLOCK
- 24. WASHER
- 25. HEX HEAD SCREW
- 26. PULLEY
- 27. NUT
- 28. LOCKWASHER (3)
- 29. HEX HEAD SCREW (3)
- 30. NUT (2)
- 31. WASHER (2)
- 32. MOUNTING BRACKET
- 33. ALTERNATOR
- 34. WIRE 10A-10V (2)

TA 237177

**ELECTRICAL SYSTEM.**

**3-71. ALTERNATOR DRIVE BELTS REPLACEMENT.**

**This task covers:**

- a. Removal
- b. Installation
- c. Adjustment

**INITIAL SETUP:**

<b><u>APPLICABLE CONFIGURATIONS</u></b>	<b><u>EQUIPMENT CONDITION PARAGRAPH</u></b>	<b><u>CONDITION DESCRIPTION</u></b>
All.	None.	None.
<b><u>TEST EQUIPMENT</u></b>		
None.		
<b><u>SPECIAL TOOLS</u></b>		
None.		
<b><u>MATERIALS/PARTS (P/N)</u></b>		
Alternator drive belt, matched pair (11288) 9429178.		
<b><u>PERSONNEL REQUIRED</u></b>	<b><u>SPECIAL ENVIRONMENTAL CONDITIONS</u></b>	
One (MOS-63S).	Vehicle parked on level ground.	
<b><u>REFERENCES (TM)</u></b>	<b><u>GENERAL SAFETY INSTRUCTIONS</u></b>	
TM 9-2320-283-20P.	Engine off. Transmission in neutral. Park brake set.	
<b><u>TROUBLESHOOTING REFERENCES</u></b>		
Paragraph 2-11.		

**ELECTRICAL SYSTEM.**

**3-71. ALTERNATOR DRIVE BELTS REPLACEMENT (Continued).**

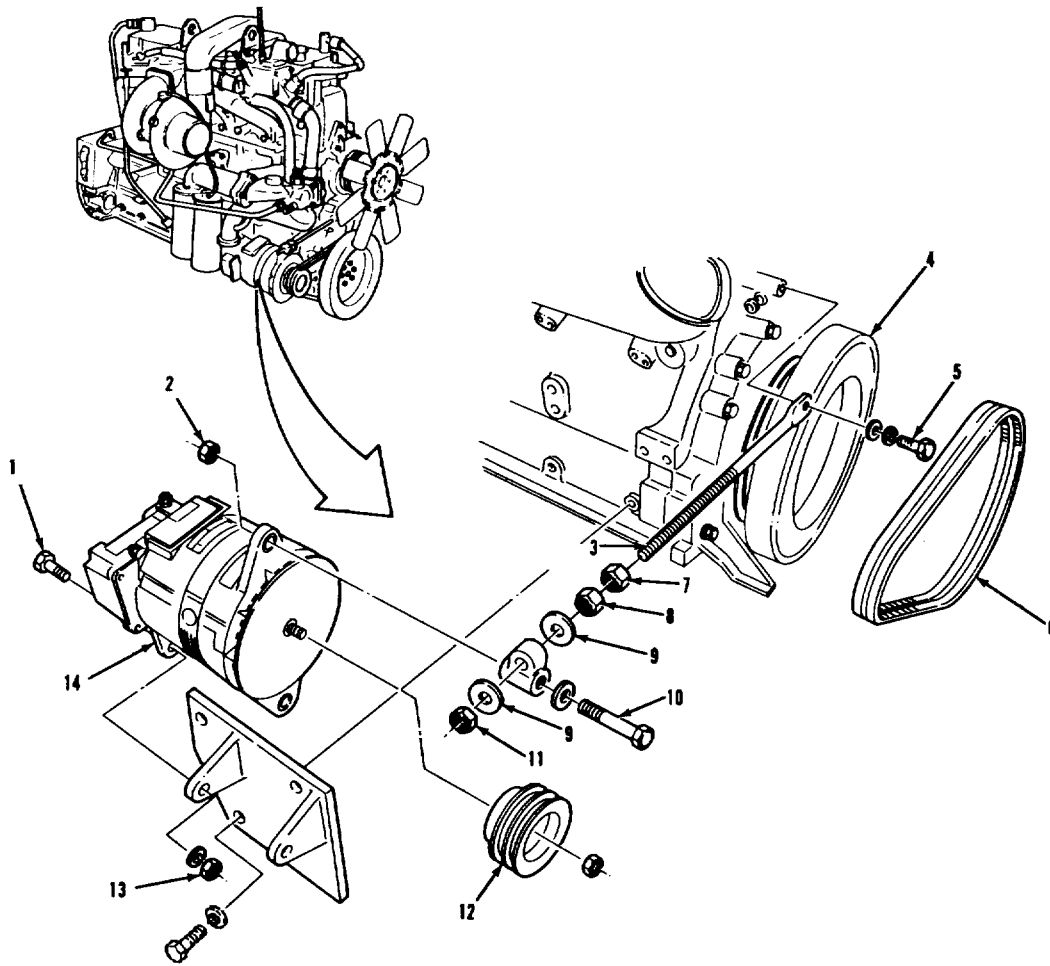

**LEGEND:**

- |                             |                         |
|-----------------------------|-------------------------|
| 1. HEX HEAD SCREW (2)       | 8. JAM NUT              |
| 2. NUT                      | 9. WASHER (2)           |
| 3. ALTERNATOR ADJUSTING ROD | 10. HEX HEAD SCREW      |
| 4. VIBRATION DAMPER         | 11. JAM NUT             |
| 5. HEX HEAD SCREW           | 12. PULLEY              |
| 6. BELT (2)                 | 13. NUT (2)             |
| 7. JAM NUT                  | 14. ALTERNATOR ASSEMBLY |

TA 237178

**ELECTRICAL SYSTEM.****3-71. ALTERNATOR DRIVE BELTS REPLACEMENT (Continued).**

LOCATION/ITEM	ACTION	REMARKS
<b>A. REMOVAL</b>		
1. Alternator assembly (14), two hex head screws (1), and two nuts (13).	Loosen.	
2. Hex head screws (10) and nut (2).	Loosen.	
3. Alternator adjusting rod (3) and hex head screw (5).	Loosen item (5).	
4. Jam nut (7), jam nut (8), and jam nut (11) enough to remove two items (6).	Loosen	Loosen item (7) and (8) to allow item (14) to move toward engine
5. Two alternator drive belts (6)	Remove items (6)	Items (6) are a matched set.
<b>B. INSTALLATION.</b>		
6. Two new alternator drive belts (6)	Install items (6) over item (4) and item (12). Move item (14) away from engine until items (6) stop travel of item (14)	Do not pry on with screwdriver Always replace items (6) as a matched set. Never put on just one new belt.



ELECTRICAL SYSTEM.

3-71. ALTERNATOR DRIVE BELTS REPLACEMENT (Continued).

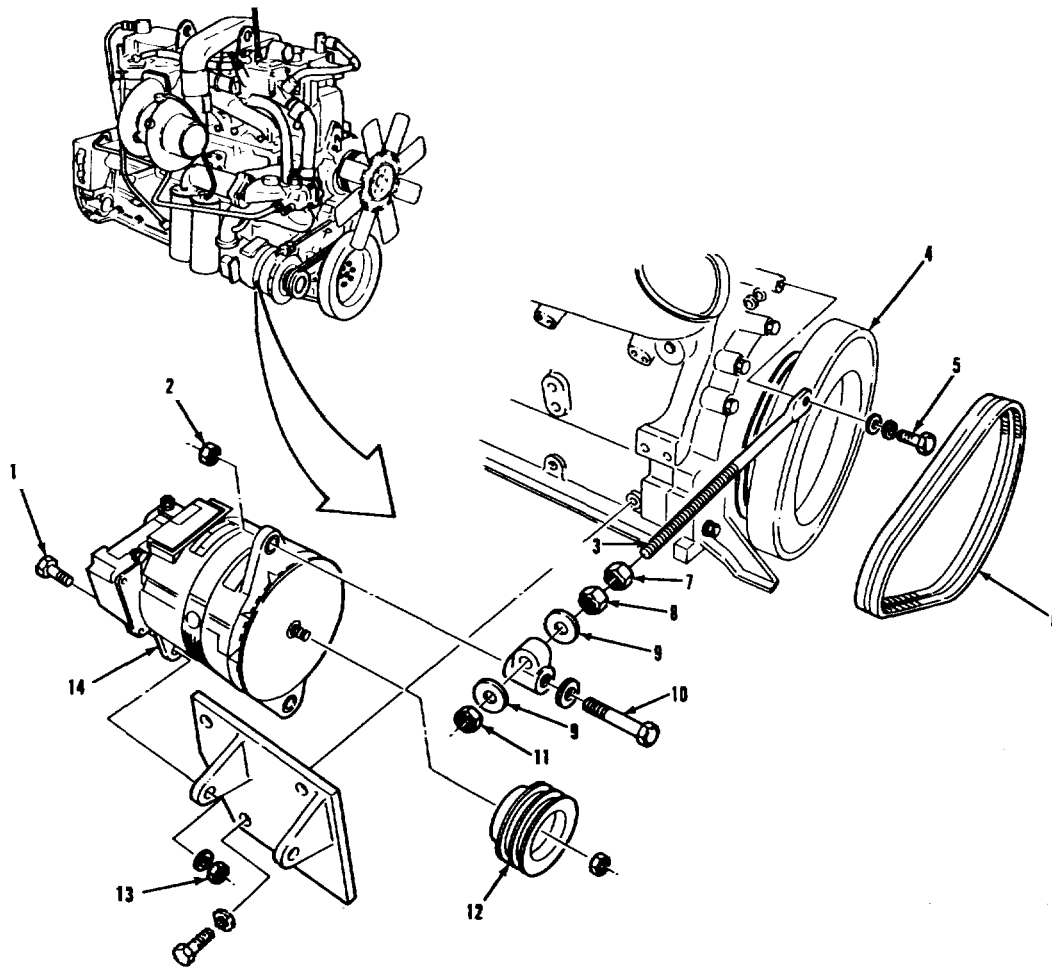

LEGEND:

- |                             |                         |
|-----------------------------|-------------------------|
| 1. HEX HEAD SCREW (2)       | 8. JAM NUT              |
| 2. NUT                      | 9. WASHER (2)           |
| 3. ALTERNATOR ADJUSTING ROD | 10. HEX HEAD SCREW      |
| 4. VIBRATION DAMPER         | 11. JAM NUT             |
| 5. HEX HEAD SCREW           | 12. PULLEY              |
| 6. BELT (2)                 | 13. NUT (2)             |
| 7. JAM NUT                  | 14. ALTERNATOR ASSEMBLY |

TA 237179

**ELECTRICAL SYSTEM.****3-71. ALTERNATOR DRIVE BELTS REPLACEMENT (Continued).**

LOCATION/ITEM	ACTION	REMARKS
<b><u>ADJUSTMENT</u></b>		
7. Jam nut (8)	Tighten item (8) against item (9) until tension of two items (6) is 110 lbs for new belts, or 80 lbs for used belts as measured with a suitable belt tension gage.	A used belt is one that has been on the truck more than a thousand miles.
8. Jam nut (11)	Tighten item (11) against item (9).	
9. Jam nut (7)	Tighten item (7) against item (8).	
10. Alternator adjusting rod (3) and hex head screw (5).	Tighten item (5).	
11. Hex head screw (10) and nut (2).	Torque to 30 lb-ft.	
12. Two hex head screws (1) and two nuts (13).	Torque to 30 lb-ft.	

**NOTE**

Follow-on maintenance action required:  
None.

**3-410**

ELECTRICAL SYSTEM.

3-71. ALTERNATOR DRIVE BELTS REPLACEMENT (Continued).

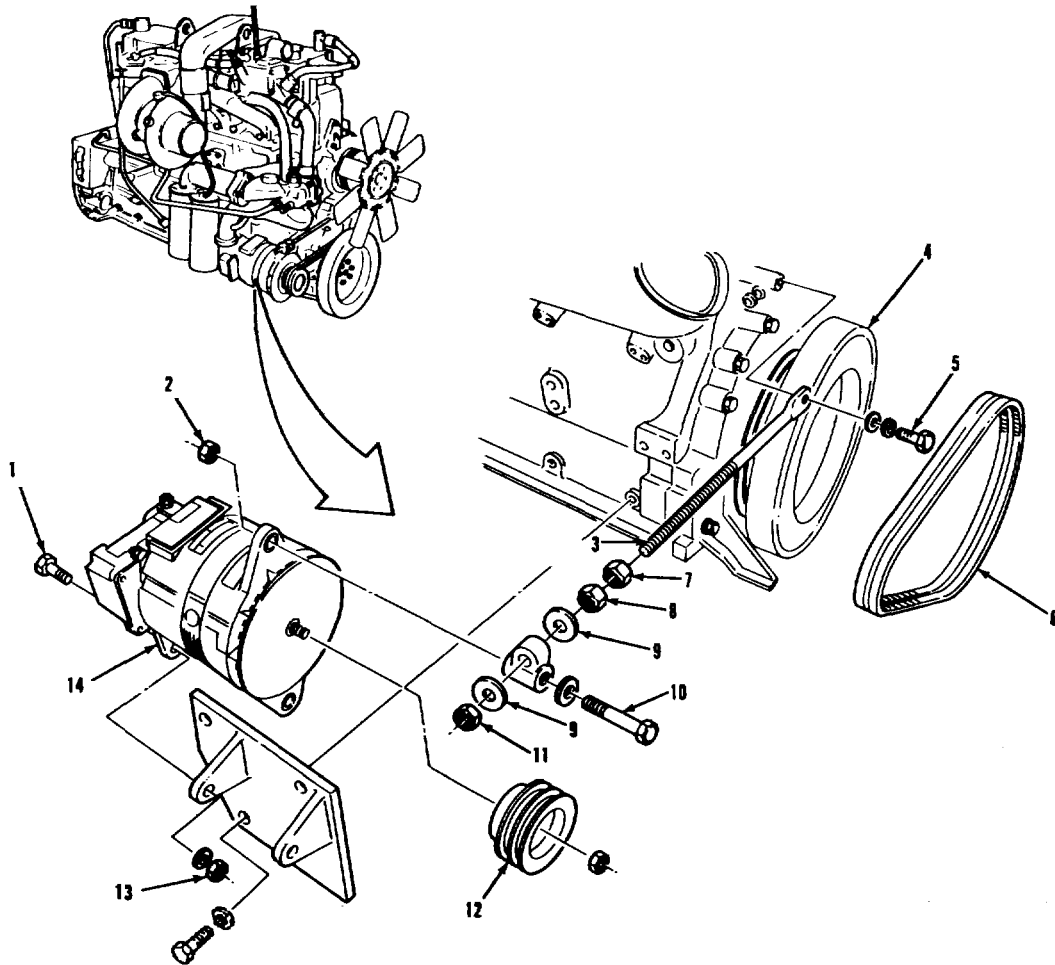

LEGEND:

- |                             |                         |
|-----------------------------|-------------------------|
| 1. HEX HEAD SCREW (2)       | 8. JAM NUT              |
| 2. NUT                      | 9. WASHER (2)           |
| 3. ALTERNATOR ADJUSTING ROD | 10. HEX HEAD SCREW      |
| 4. VIBRATION DAMPER         | 11. JAM NUT             |
| 5. HEX HEAD SCREW           | 12. PULLEY              |
| 6. BELT (2)                 | 13. NUT (2)             |
| 7. JAM NUT                  | 14. ALTERNATOR ASSEMBLY |

TA 237179

**ELECTRICAL SYSTEM.**

**3-72. STARTER MOTOR AND SOLENOID REPLACEMENT.**

**This task covers:**

- a. Removal
- b. Installation
- c. Operational Check

**INITIAL SETUP:**

<b><u>APPLICABLE CONFIGURATIONS</u></b>	<b><u>EQUIPMENT CONDITION PARAGRAPH</u></b>	<b><u>CONDITION DESCRIPTION</u></b>
All	3-120	Battery power disconnected.
<b><u>TEST EQUIPMENT</u></b> None	3-271	Left fender removed (for ease of access).
<b><u>SPECIAL TOOLS</u></b> None.		
<b><u>MATERIALS/PARTS (P/N)</u></b> Compound, thread locking Item 10, Appendix C. Rope, 10 ft.		
<b><u>PERSONNEL REQUIRED</u></b> Two (MOS-63S)	<b><u>SPECIAL ENVIRONMENTAL CONDITIONS</u></b> Vehicle parked on level ground.	
<b><u>REFERENCES (TM)</u></b> TM 9-2320-283-10 TM 9-2320-283-20P	<b><u>GENERAL SAFETY INSTRUCTIONS</u></b> Engine off. Transmission in neutral. Park brake set. Starter assembly is heavy; use caution when removing.	
<b><u>TROUBLESHOOTING REFERENCES</u></b> Paragraph 2-11.		

**ELECTRICAL SYSTEM.**

**3-72. STARTER MOTOR AND SOLENOID REPLACEMENT (Continued).**

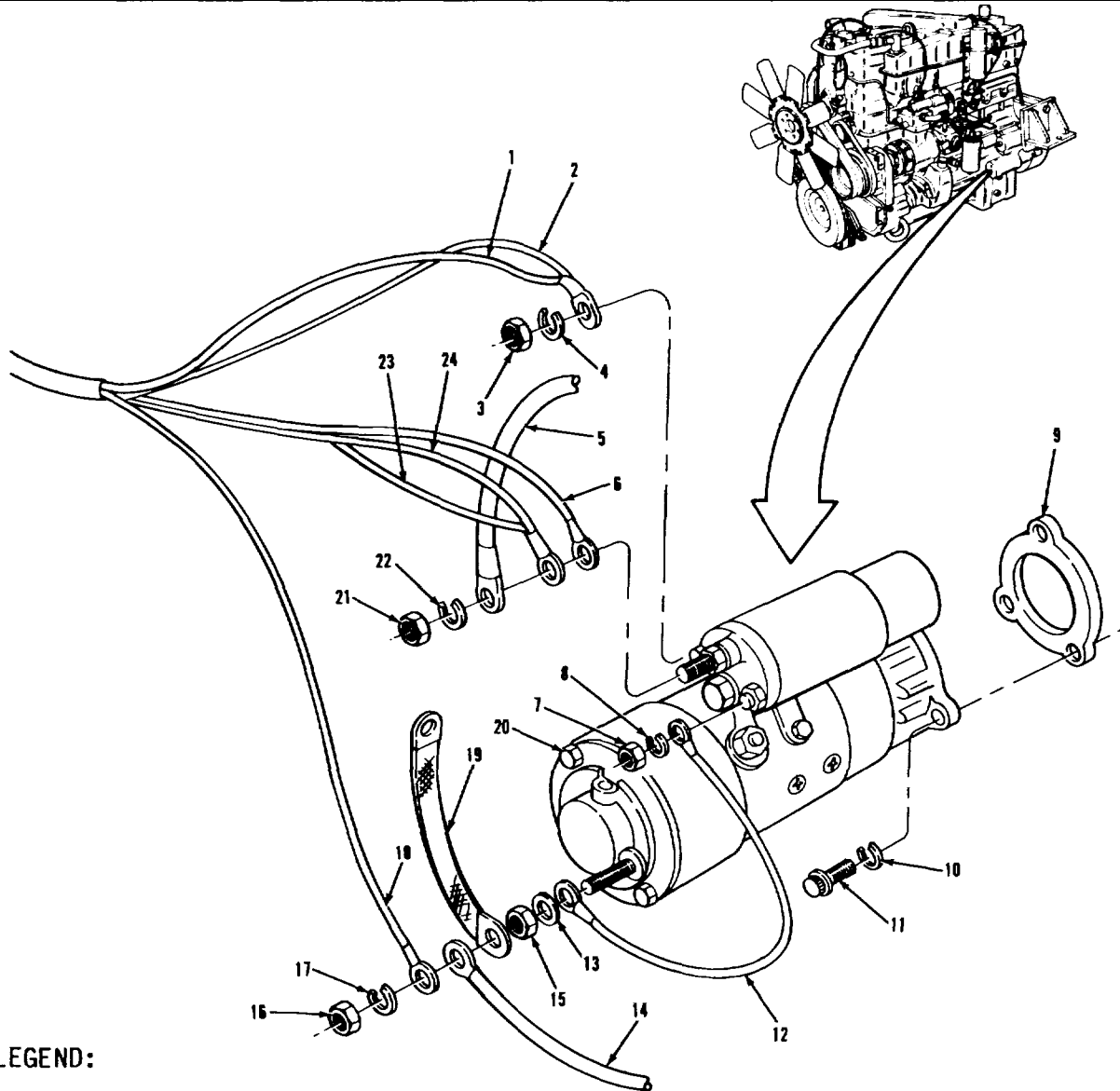

**LEGEND:**

- |                    |                         |
|--------------------|-------------------------|
| 1. WIRE (46F)      | 13. WASHER              |
| 2. WIRE (46E)      | 14. BLACK BATTERY CABLE |
| 3. HEX NUT         | 15. HEX NUT             |
| 4. LOCKWASHER      | 16. HEX NUT             |
| 5. BATTERY CABLE   | 17. LOCKWASHER          |
| 6. WIRE (17)       | 18. WIRE (98K)          |
| 7. HEX NUT         | 19. STRAP               |
| 8. LOCKWASHER      | 20. STARTER MOTOR       |
| 9. SPACER          | 21. HEX NUT             |
| 10. LOCKWASHER (3) | 22. LOCKWASHER          |
| 11. SCREW (3)      | 23. WIRE (17B)          |
| 12. BUS BAR        | 24. WIRE (46B)          |

TA 237182

**ELECTRICAL SYSTEM.**

**3-72. STARTER MOTOR AND SOLENOID REPLACEMENT (Continued).**

LOCATION/ITEM	ACTION	REMARKS
<b><u>WARNING</u></b>		
Disconnect batteries before removing starter. Failure to heed warning can result in vehicle damage and serious personnel injury.		
<b><u>A. REMOVAL.</u></b>		
1. Hex nut (21) and lockwasher (22).	Remove.	
2. Battery cable (5), wire (23), wire (24), and wire (6)	Remove	Tag to identify Item (23) and item (24) have same terminal.
3. Hex nut (16) and lockwasher (17).	Remove.	
4. Black battery cable (14), strap (19), and wire (18).	Remove	Tag to identify Do not remove item (12).
5. Hex nut (3) and lockwasher (4).	Remove.	
6. Wire (2) and wire (1).	Remove	Tag to identify Item (2) and item (1) have same terminal.

**WARNING**

Starter motor is heavy. Use extreme caution when removing. Failure to heed warning can result in equipment damage and serious personnel injury.

**NOTE**

Wrap rope around starter motor and tie securely. First mechanic hold rope while second mechanic performs steps 7, 8, 15, and 16.

**ELECTRICAL SYSTEM.**

**3-72. STARTER MOTOR AND SOLENOID REPLACEMENT (Continued).**

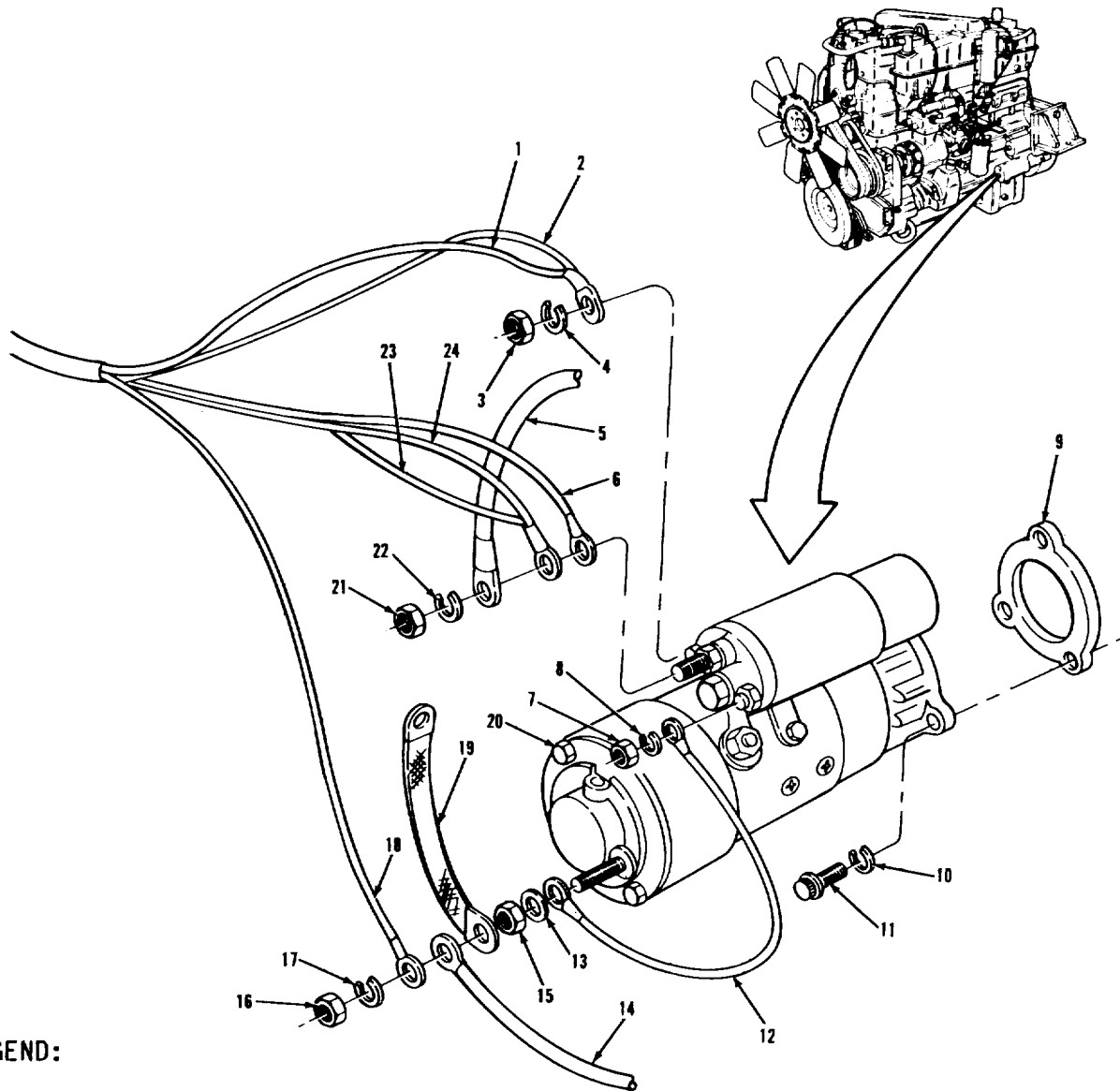

**LEGEND:**

- |                    |                         |
|--------------------|-------------------------|
| 1. WIRE (46F)      | 13. WASHER              |
| 2. WIRE (46E)      | 14. BLACK BATTERY CABLE |
| 3. HEX NUT         | 15. HEX NUT             |
| 4. LOCKWASHER      | 16. HEX NUT             |
| 5. BATTERY CABLE   | 17. LOCKWASHER          |
| 6. WIRE (17)       | 18. WIRE (98K)          |
| 7. HEX NUT         | 19. STRAP               |
| 8. LOCKWASHER      | 20. STARTER MOTOR       |
| 9. SPACER          | 21. HEX NUT             |
| 10. LOCKWASHER (3) | 22. LOCKWASHER          |
| 11. SCREW (3)      | 23. WIRE (17B)          |
| 12. BUS BAR        | 24. WIRE (46B)          |

TA 237183

**ELECTRICAL SYSTEM.****3-72. STARTER MOTOR AND SOLENOID REPLACEMENT (Continued).**

LOCATION/ITEM	ACTION	REMARKS
<b>A. REMOVAL (Continued).</b>		
7. Three screws (11) and three lock-washers (10).	Remove.	
8. Starter motor (20)	Remove.-	First mechanic lowers item (20) from side of engine to ground level.
9. Spacer (9) 10. Hex nut (7), lock-washer (8), and bus bar (12).	Remove. Remove from item (20).	
11. Hex nut (15), washer (13), and bus bar (12).	Remove from item (20).	
<b>B. INSTALLATION.</b>		
12. Bus bar (12)	Install on item (20).	
13. Hex nut (15) and washer (13).	Install and tighten.	
14. Hex nut (7) and lockwasher (8).	Install and tighten.	
15. Spacer (9)	Aline and install on item (20).	
16. Starter motor (20)	Aline and install	First mechanic raises item (20) into position.
17. Three screws (11) and three lock-washers (10)	a. Apply thread locking compound to threads of three items (11). b. Install and tighten.	



ELECTRICAL SYSTEM.

3-72. STARTER MOTOR AND SOLENOID REPLACEMENT (Continued).

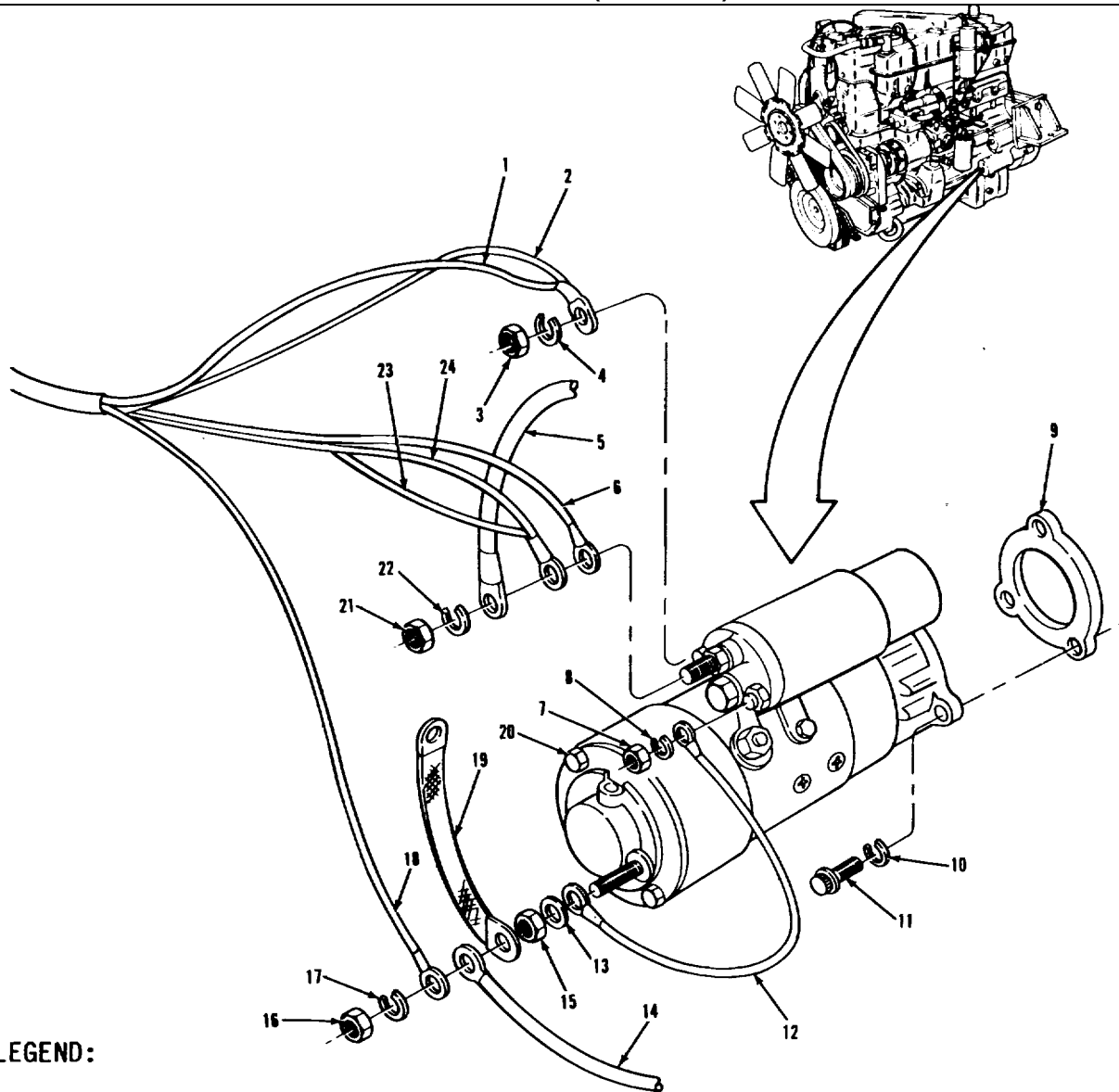

LEGEND:

- |                    |                         |
|--------------------|-------------------------|
| 1. WIRE (46F)      | 13. WASHER              |
| 2. WIRE (46E)      | 14. BLACK BATTERY CABLE |
| 3. HEX NUT         | 15. HEX NUT             |
| 4. LOCKWASHER      | 16. HEX NUT             |
| 5. BATTERY CABLE   | 17. LOCKWASHER          |
| 6. WIRE (17)       | 18. WIRE (98K)          |
| 7. HEX NUT         | 19. STRAP               |
| 8. LOCKWASHER      | 20. STARTER MOTOR       |
| 9. SPACER          | 21. HEX NUT             |
| 10. LOCKWASHER (3) | 22. LOCKWASHER          |
| 11. SCREW (3)      | 23. WIRE (17B)          |
| 12. BUS BAR        | 24. WIRE (46B)          |

TA 237184

**ELECTRICAL SYSTEM.**

<b>3-72. STARTER MOTOR AND SOLENOID REPLACEMENT (Continued).</b>		
<b>LOCATION/ITEM</b>	<b>ACTION</b>	<b>REMARKS</b>
<b><u>B. INSTALLATION (Continued).</u></b>		
18. Wire (2) and wire (1)	Install	Connect according to identification tag from step 6.
19. Lockwasher (4) and hex nut (3).	Install and tighten.	
20. Strap (19), black battery cable (14), and wire (18).	Install identification tag from step 4.	Connect according to
21. Lockwasher (17) and hex nut (16).	Install and tighten.	
22. Battery cable (5), wire (23), wire (24), and wire (6).	Install identification tag from step 2.	Connect according to
23. Lockwasher (22) and hex nut (21).	Install and tighten.	
24. Batteries	Connect	Refer to paragraph 3-120.
<b>C. OPERATIONAL CHECK.</b>		
25. Engine	Start up (20) engages	Verify that item 10. Refer to TM 9-2320-283-
<b>Follow-on maintenance action required: Install left fender (para 3-271).</b>		
		<b>NOTE</b>
		<b>3-418</b>

ELECTRICAL SYSTEM.

3-72. STARTER MOTOR AND SOLENOID REPLACEMENT (Continued).

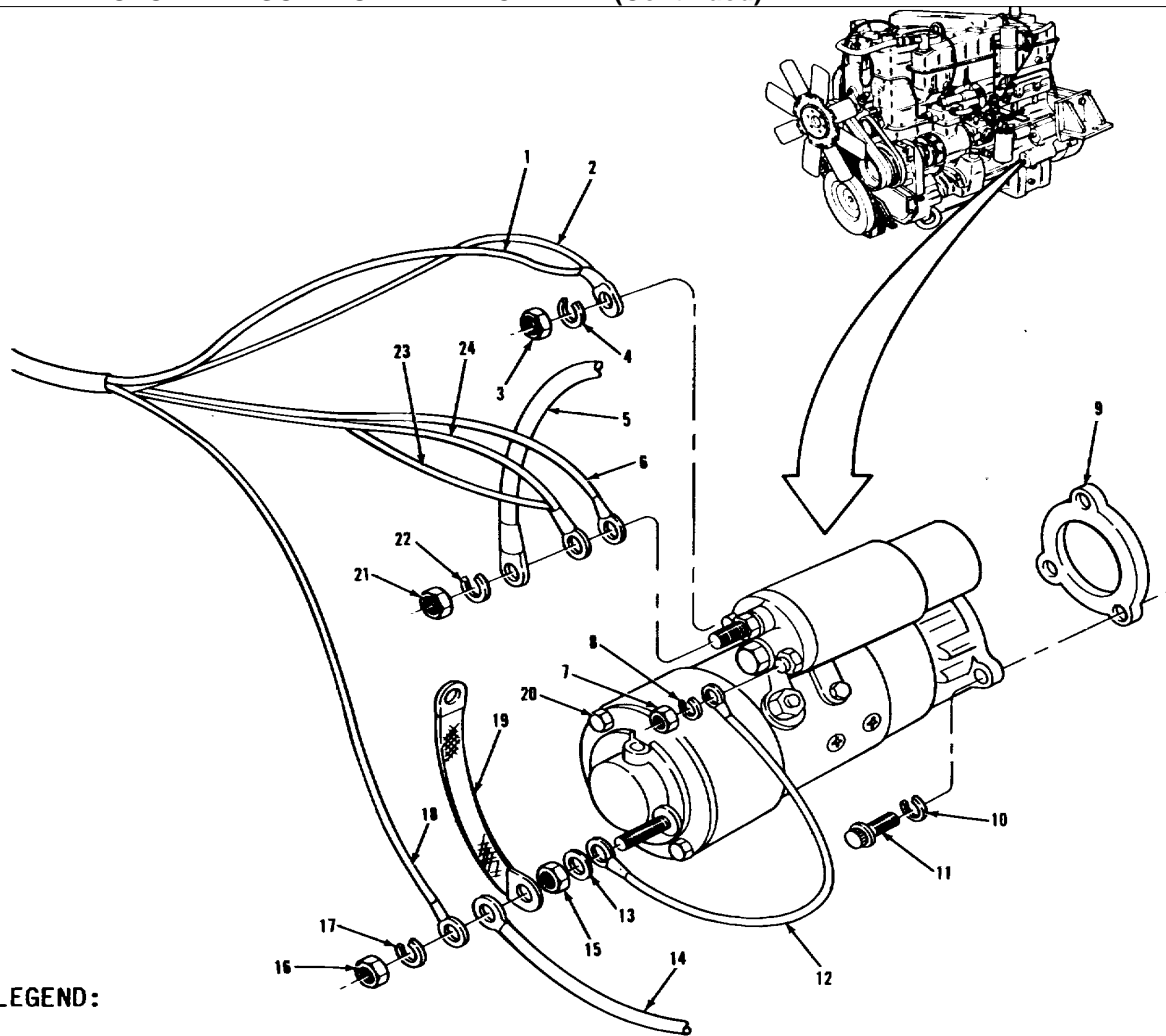

LEGEND:

- |                    |                         |
|--------------------|-------------------------|
| 1. WIRE (46F)      | 13. WASHER              |
| 2. WIRE (46E)      | 14. BLACK BATTERY CABLE |
| 3. HEX NUT         | 15. HEX NUT             |
| 4. LOCKWASHER      | 16. HEX NUT             |
| 5. BATTERY CABLE   | 17. LOCKWASHER          |
| 6. WIRE (17)       | 18. WIRE (98K)          |
| 7. HEX NUT         | 19. STRAP               |
| 8. LOCKWASHER      | 20. STARTER MOTOR       |
| 9. SPACER          | 21. HEX NUT             |
| 10. LOCKWASHER (3) | 22. LOCKWASHER          |
| 11. SCREW (3)      | 23. WIRE (17B)          |
| 12. BUS BAR        | 24. WIRE (46B)          |

TA 237184

**ELECTRICAL SYSTEM.****3-73. LEFT-HAND INSTRUMENT PANEL GAGE REPLACEMENT.**

---

**This task covers:**

- a. Removal
  - b. Installation
  - c. Inspection
- 

**INITIAL SETUP:**

<b><u>APPLICABLE CONFIGURATIONS</u></b>	<b><u>EQUIPMENT CONDITION PARAGRAPH</u></b>	<b><u>CONDITION DESCRIPTION</u></b>
All.	3-120.	Battery power disconnected.

**TEST EQUIPMENT**

None.

**SPECIAL TOOLS**

None.

**MATERIALS/PARTS (P/N)**

None.

**PERSONNEL REQUIRED**

One (MOS-63S).

**REFERENCES (TM)**

TM 9-2320-283-10.

**SPECIAL ENVIRONMENTAL CONDITIONS**

Vehicle parked on level ground.

**GENERAL SAFETY INSTRUCTIONS**

Engine off.

Transmission in neutral.

Park brake set.

**TROUBLESHOOTING REFERENCES**

Paragraph 2-11.

**ELECTRICAL SYSTEM.**

**3-73. LEFT-HAND INSTRUMENT PANEL GAGE REPLACEMENT (Continued).**

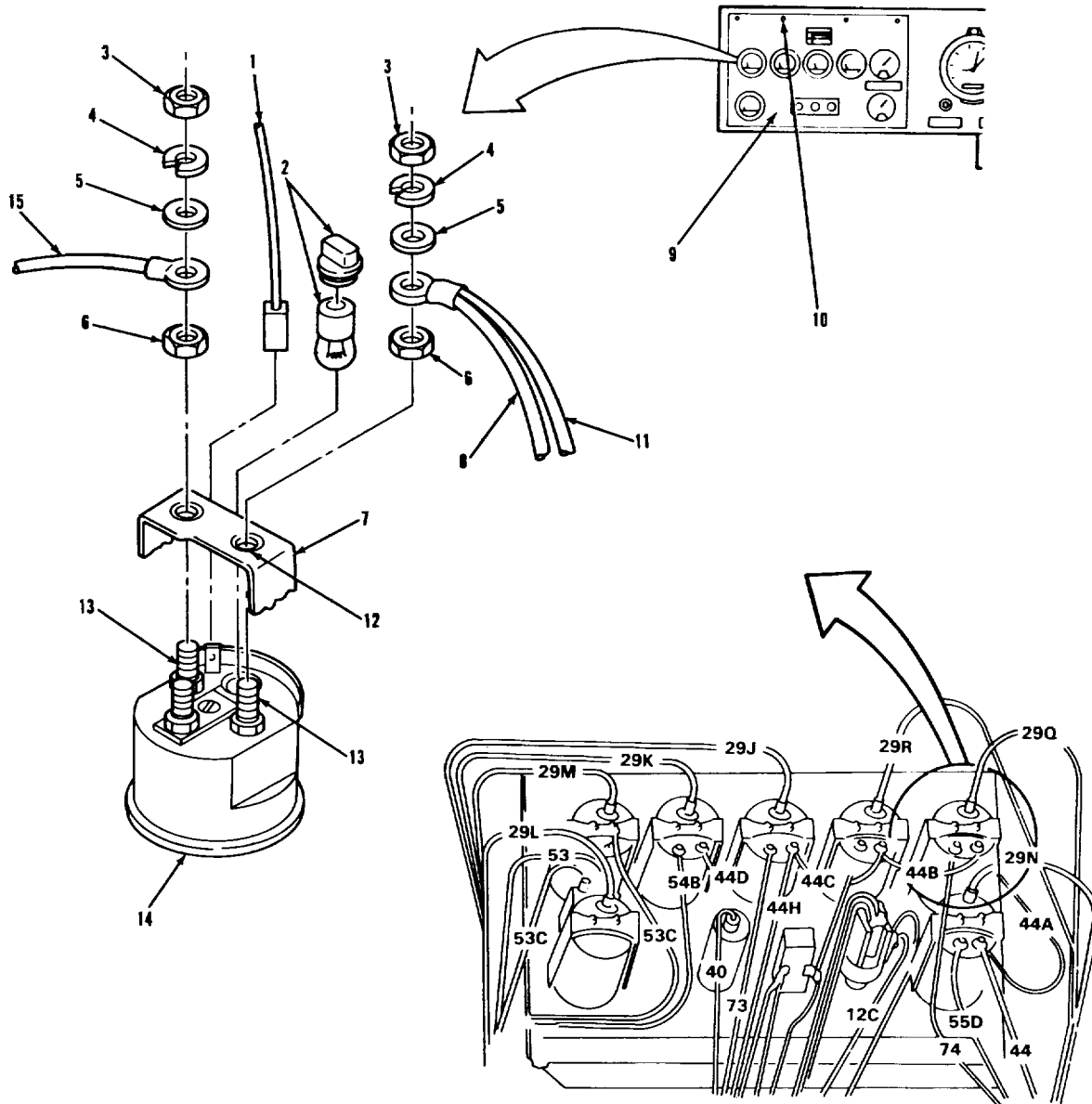

**LEGEND:**

- |                             |                            |
|-----------------------------|----------------------------|
| 1. WIRE (29P)               | 9. INSTRUMENT PANEL        |
| 2. SOCKET AND BULB ASSEMBLY | 10. QUARTER-TURN SCREW (4) |
| 3. NUT (2)                  | 11. WIRE (44B)             |
| 4. LOCKWASHER (2)           | 12. INSULATING INSERT (2)  |
| 5. WASHER (2)               | 13. TERMINAL STUD (2)      |
| 6. NUT (2)                  | 14. FUEL GAGE              |
| 7. BRACKET                  | 15. WIRE (74)              |
| 8. WIRE (44A)               |                            |

TA 237185

ELECTRICAL SYSTEM.

3-73. LEFT-HAND INSTRUMENT PANEL GAGE REPLACEMENT (Continued).		
LOCATION/ITEM	ACTION	REMARKS
<b>NOTE</b>		
The gages covered in the following procedure are identical as far as removal and installation; therefore, only one is covered.		
<b>A. REMOVAL.</b>		
1. Four quarter-turn screws (10).	Loosen.	
2. Hinged instrument panel (9).	Lower.	
3. Wire connector (1).	Remove	Tag for identification.
4. Two nuts (3), two lockwashers (4), and two flat washers (5).	Remove.	
5. Wire (8), wire (11), and wire (15)	Remove	Tag for identification. Items (8) and (11) share a common terminal type connector.
6. Two nuts (6)	Remove.	
7. Bracket (7), two insulating inserts (12)	Remove (7) of two items (12)	Note position Hold item (14) to prevent it from falling out when removing item (7).
8. Fuel gage (14)	Remove.	
9. Socket and bulb assembly (2)	Remove by turning a quarter turn to the left.	
<b>B. INSTALLATION. I</b>		
10. Socket and bulb assembly (2).	Install.	
11. Fuel gage (14)	Aline and insert in item (9).	

**ELECTRICAL SYSTEM.**

**3-73. LEFT-HAND INSTRUMENT PANEL GAGE REPLACEMENT (Continued).**

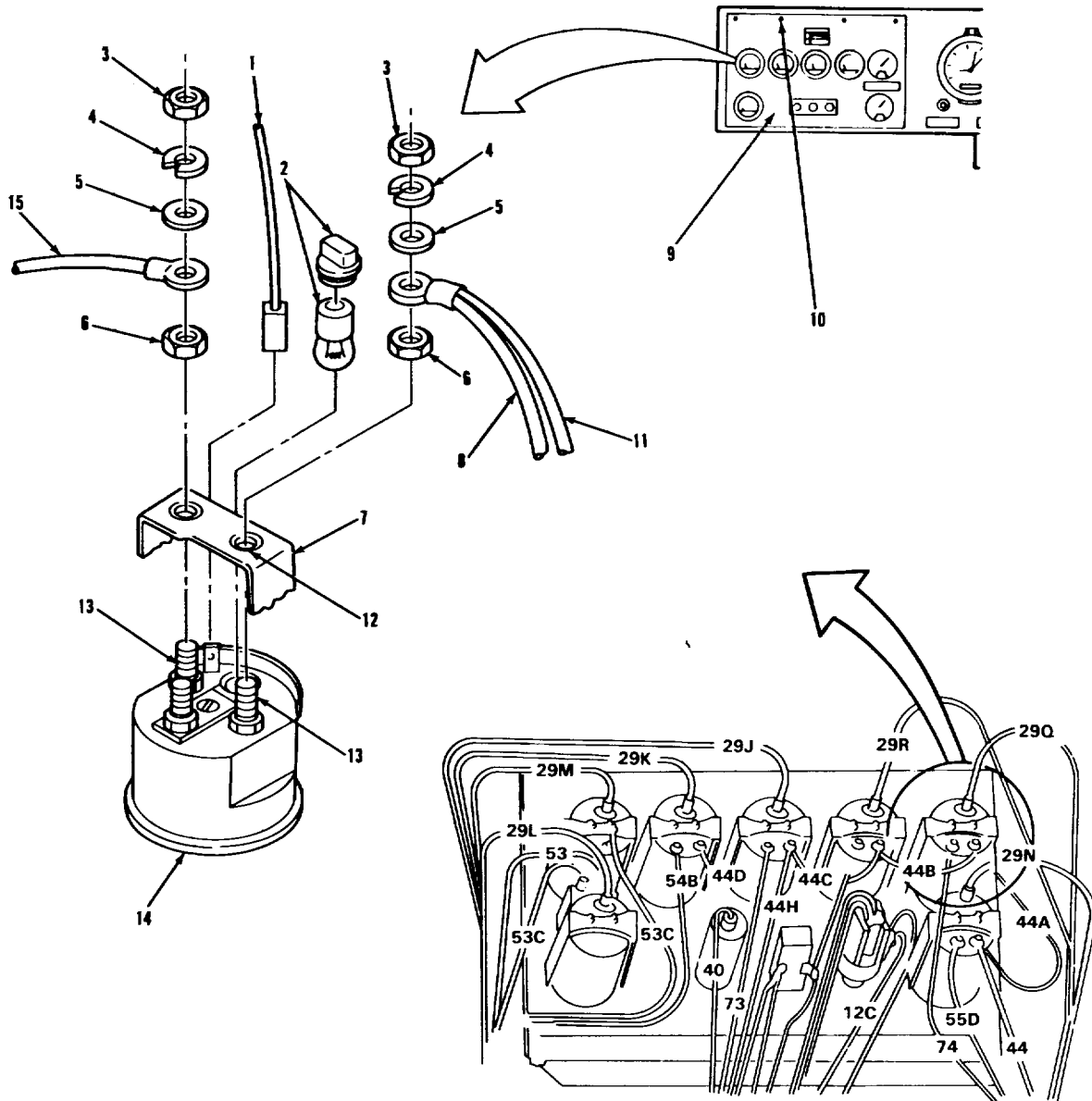

**LEGEND:**

- |                             |                            |
|-----------------------------|----------------------------|
| 1. WIRE (29P)               | 9. INSTRUMENT PANEL        |
| 2. SOCKET AND BULB ASSEMBLY | 10. QUARTER-TURN SCREW (4) |
| 3. NUT (2)                  | 11. WIRE (44B)             |
| 4. LOCKWASHER (2)           | 12. INSULATING INSERT (2)  |
| 5. WASHER (2)               | 13. TERMINAL STUD (2)      |
| 6. NUT (2)                  | 14. FUEL GAGE              |
| 7. BRACKET                  | 15. WIRE (74)              |
| 8. WIRE (44A)               |                            |

TA 237186

ELECTRICAL SYSTEM.

3-73. LEFT-HAND INSTRUMENT PANEL GAGE REPLACEMENT (Continued).		
LOCATION/ITEM	ACTION	REMARKS
<b><u>B. INSTALLATION (Continued).</u></b>		
12. Bracket (7), two insulating inserts (12), and two terminal studs (13).	Install item (7) on back of item (14) with two items (12) aligned with two items (13).	
13. Two nuts (6)	Install and tighten	Do not overtighten.
14. Wire (8), wire (11), and wire (15)	Install on two items (13) identification tags from step 5.	Connect according to
15. Two flatwashers (5), two lockwashers (4), and two nuts (3).	Install and tighten.	
16. Wire connector (1) identification tags from step 5.	Install	Connect according to
17. Hinged instrument panel (9).	Raise into place.	
18. Four quarter-turn screws (10).	Tighten.	
19. Batteries	Connect	Refer to paragraph 3-120.
<b><u>C. OPERATIONAL CHECK.</u></b>		
20. Engine	Start up	Refer to TM 9-2320-283-10.
21. Gages verify operation.	Observe gage replaced and	
	<b>NOTE</b>	
	Follow-on maintenance action required: None.	
	<b>3-424</b>	



ELECTRICAL SYSTEM.

3-73. LEFT-HAND INSTRUMENT PANEL GAGE REPLACEMENT (Continued).

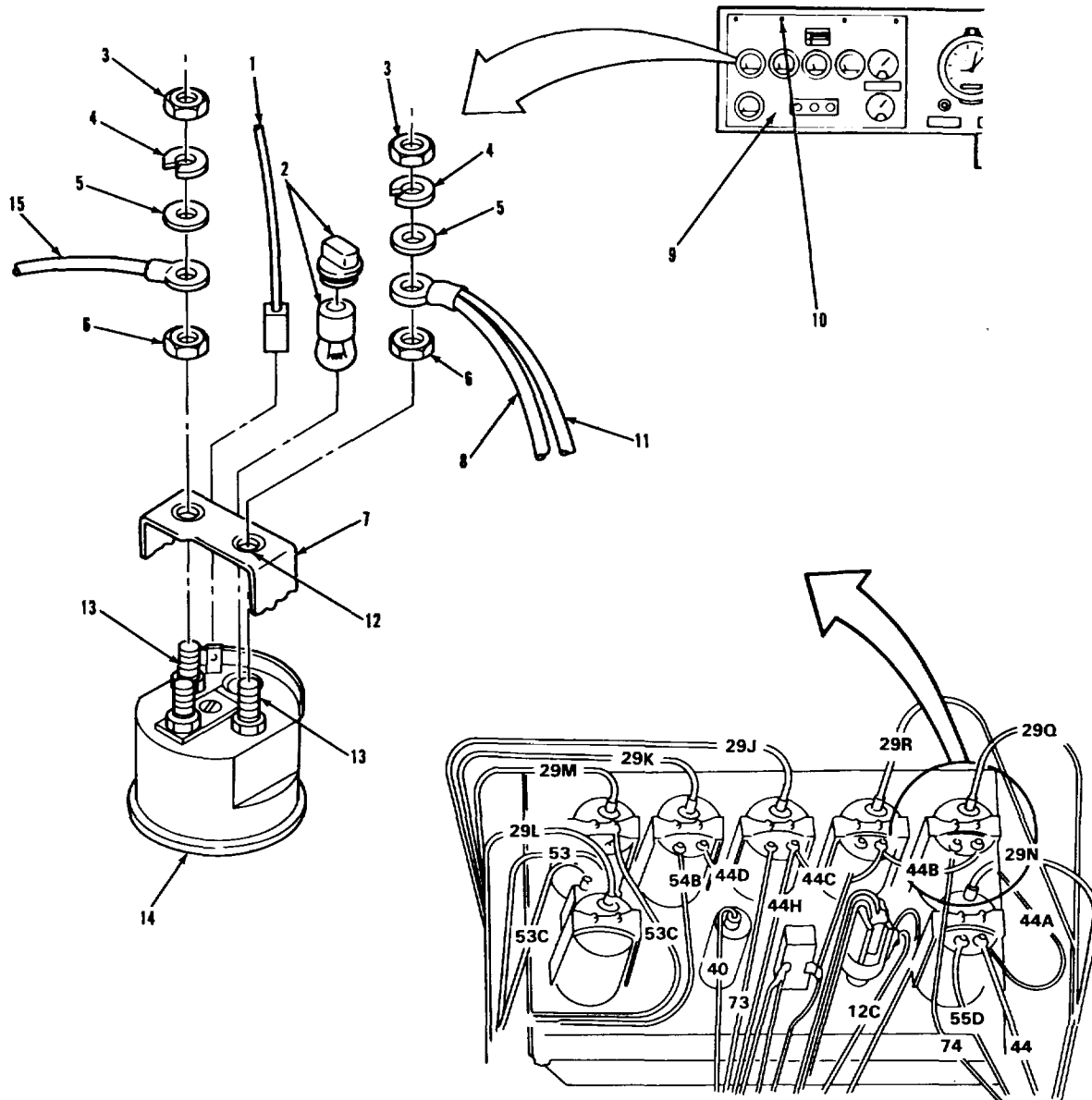

LEGEND:

- 1. WIRE (29P)
- 2. SOCKET AND BULB ASSEMBLY
- 3. NUT (2)
- 4. LOCKWASHER (2)
- 5. WASHER (2)
- 6. NUT (2)
- 7. BRACKET
- 8. WIRE (44A)

- 9. INSTRUMENT PANEL
- 10. QUARTER-TURN SCREW (4)
- 11. WIRE (44B)
- 12. INSULATING INSERT (2)
- 13. TERMINAL STUD (2)
- 14. FUEL GAGE
- 15. WIRE (74)

TA 237187

**ELECTRICAL SYSTEM.**  
**3-74. IGNITION SWITCH REPLACEMENT.**

---

**This task covers:**

- a. Removal
  - b. Installation
  - c. Inspection
- 

**INITIAL SETUP:**

**APPLICABLE CONFIGURATIONS**

All.  
 disconnected.

**TEST EQUIPMENT**

None.

**SPECIAL TOOLS**

None.

**MATERIALS/PARTS (P/N)**

None.

**PERSONNEL REQUIRED**

One (MOS-63S).

**REFERENCES (TM)**

TM 9-2320-283-10.

**TROUBLESHOOTING REFERENCES**

Paragraph 2-11.

**EQUIPMENT CONDITION**

**PARAGRAPH**

3-120.

**CONDITION DESCRIPTION**

Battery power

**SPECIAL ENVIRONMENTAL CONDITIONS**

Vehicle parked on level ground.

**GENERAL SAFETY INSTRUCTIONS**

Engine off.

Transmission in neutral.

Park brake set.

**ELECTRICAL SYSTEM.**

**3-74. IGNITION SWITCH REPLACEMENT (Continued).**

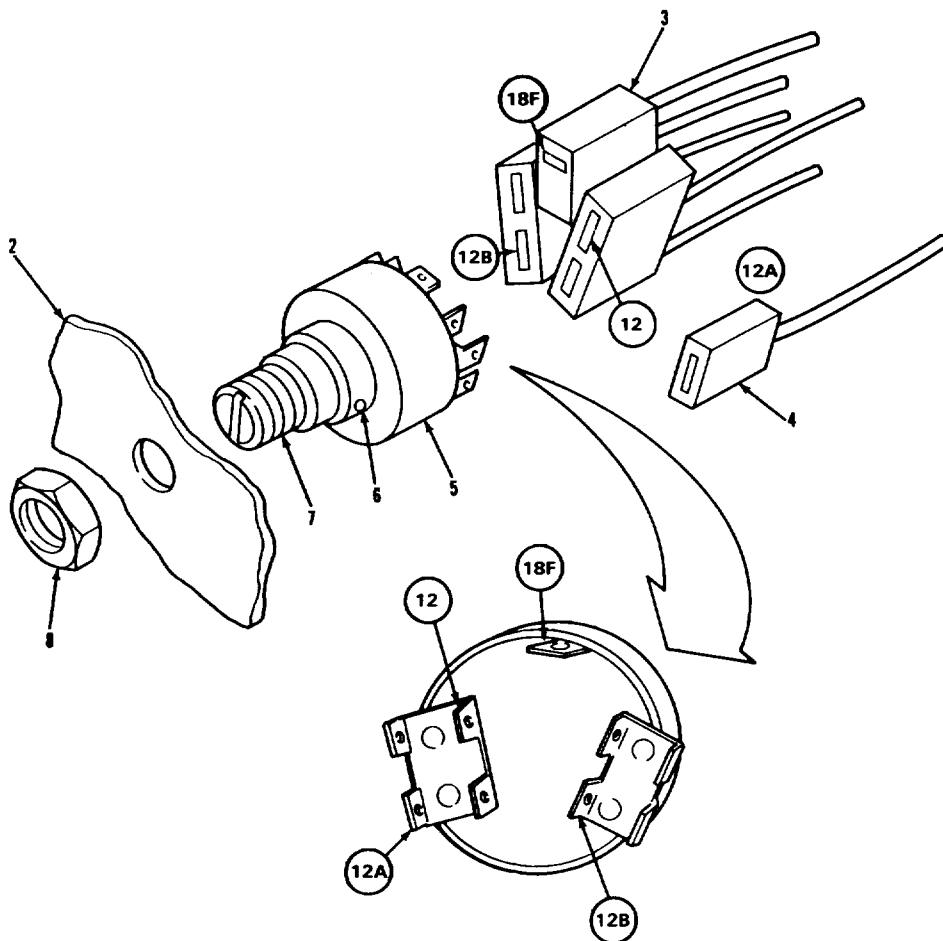
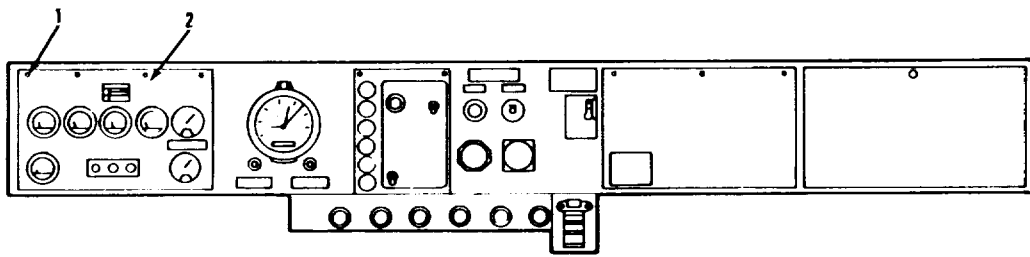

**LEGEND:**

- 1. QUARTER-TURN SCREW (4)
- 2. INSTRUMENT PANEL
- 3. WIRE CONNECTOR (12B-18F-12)
- 4. WIRE (12A)

- 5. IGNITION SWITCH
- 6. CYLINDER EXTRACTION HOLE
- 7. LOCK CYLINDER
- 8. HEX NUT

TA 237188

**ELECTRICAL SYSTEM.**

**3-74. IGNITION SWITCH REPLACEMENT (Continued).**

LOCATION/ITEM	ACTION	REMARKS
<b><u>A. REMOVAL.</u></b>		
1. Four screws (1)	Loosen.	
2. Panel (2)	Lower.	
3. Wire connectors (3) and (4).	Remove.	
4. Nut (8)	Remove.	
5. Switch (5)	Remove from item (2).	
6. Lock cylinder (7) and cylinder extraction hole (6)	Insert key and place item (5) in ON position Insert flat tip punch in item (6) and remove item (7).	
<b><u>B. INSTALLATION.</u></b>		
7. Lock cylinder (7)	Aline and press in item (5).	
8. Switch (5)	Aline and insert in item (2).	
9. Nut (8)	Install and tighten.	
10. Wire connectors (3) and (4).	Install on item (5).	
11. Panel (2)	Raise into place.	
12. Four screws (1)	Tighten.	
13. Batteries	Connect	Refer to paragraph 3-120.
<b><u>C. OPERATIONAL CHECK. I</u></b>		
14. Engine	Startup circuits are operational	Verify that all Refer to TM 9-2320-283-10.
<b>NOTE</b>		
<p><b>Follow-on maintenance action required: Connect battery power (para 3-120).</b></p>		

**ELECTRICAL SYSTEM.**

**3-74. IGNITION SWITCH REPLACEMENT (Continued).**

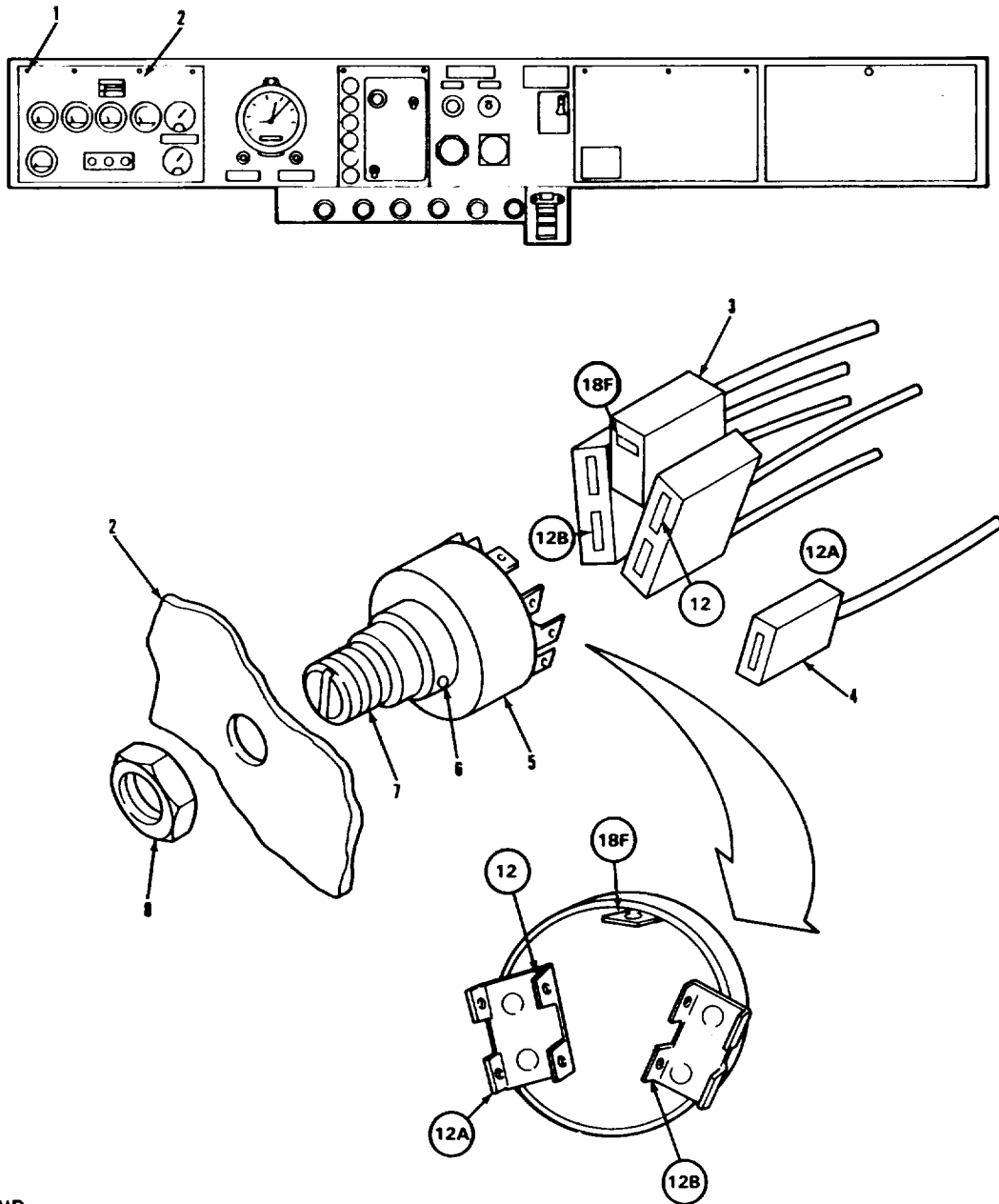

**LEGEND:**

- 1. QUARTER-TURN SCREW (4)
- 2. INSTRUMENT PANEL
- 3. WIRE CONNECTOR (12B-18F-12)
- 4. WIRE (12A)

- 5. IGNITION SWITCH
- 6. CYLINDER EXTRACTION HOLE
- 7. LOCK CYLINDER
- 8. HEX NUT

TA 237189

**ELECTRICAL SYSTEM.**

**3-75. PUSHBUTTON STARTER SWITCH REPLACEMENT.**

**This task covers:**

- a. Removal
- b. Installation
- c. Inspection

**INITIAL SETUP:**

**APPLICABLE CONFIGURATIONS**

All.

**EQUIPMENT CONDITION**

**PARAGRAPH**

3-120.

**CONDITION DESCRIPTION**

Battery power disconnected.

**TEST EQUIPMENT**

None.

**SPECIAL TOOLS**

None.

**MATERIALS/PARTS (P/N)**

None.

**PERSONNEL REQUIRED**

One (MOS-63S).

**REFERENCES (TM)**

TM 9-2320-283-10.

**SPECIAL ENVIRONMENTAL CONDITIONS**

Vehicle parked on level ground.

**GENERAL SAFETY INSTRUCTIONS**

Engine off.

Transmission in neutral.

Park brake set.

**TROUBLESHOOTING REFERENCES**

Paragraph 2-11.

**ELECTRICAL SYSTEM.**

**3-75. PUSHBUTTON STARTER SWITCH REPLACEMENT (Continued).**

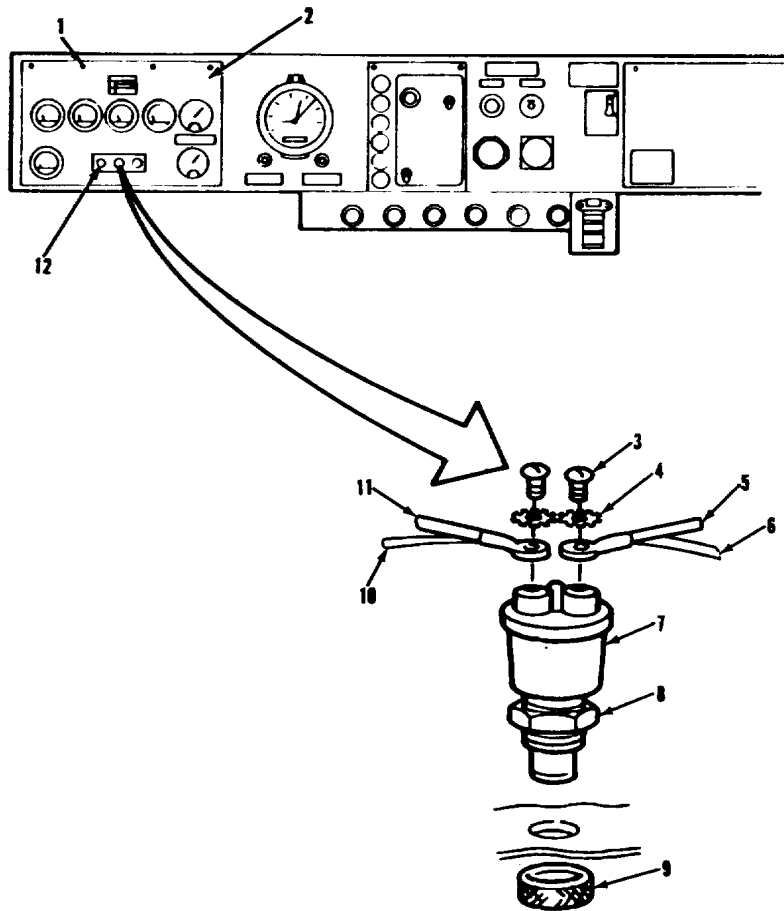

**LEGEND:**

- |                           |                              |
|---------------------------|------------------------------|
| 1. QUARTER-TURN SCREW (4) | 7. STARTER PUSHBUTTON SWITCH |
| 2. INSTRUMENT PANEL       | 8. ADJUSTING HEX NUT         |
| 3. SCREW (2)              | 9. KNURLED NUT               |
| 4. LOCKWASHER (2)         | 10. WIRE (98E)               |
| 5. WIRE (46)              | 11. WIRE (98F)               |
| 6. WIRE (55C)             | 12. IGNITION SWITCH          |

TA 237190

**ELECTRICAL SYSTEM.**

<b>3-75. PUSHBUTTON STARTER SWITCH REPLACEMENT (Continued).</b>		
<b>LOCATION/ITEM</b>	<b>ACTION</b>	<b>REMARKS</b>
<b>A. REMOVAL.</b>		
1. Four screws (1)	Loosen.	
2. Panel (2)	Lower.	
3. Two screws (3) and lockwashers (4).	Remove.	
4. Wire (5), wire (6), wire (10) and wire (11)	Remove	Tag for identification. Item (5) and (6) share a common terminal Items (10) and (11) share a common terminal.
5. Knurled nut (8)	Remove.	
6. Starter push-button switch (7).	Remove.	
7. Adjusting hex nut (8).	Remove.	
<b>B. INSTALLATION.</b>		
8. Adjusting hex nut (7)	Install and adjust to proper depth on item (7) to allow installation of item (9). Replace in item (2).	
9. Starter push-button switch (7).		
10. Knurled nut (9)	Install and tighten.	
11. Wire (5), wire (6), wire (10), wire (11), two screws (3), and lockwasher (4).	Install	Connect according to identification tag from step 4.



ELECTRICAL SYSTEM.

3-75. PUSHBUTTON STARTER SWITCH REPLACEMENT (Continued).

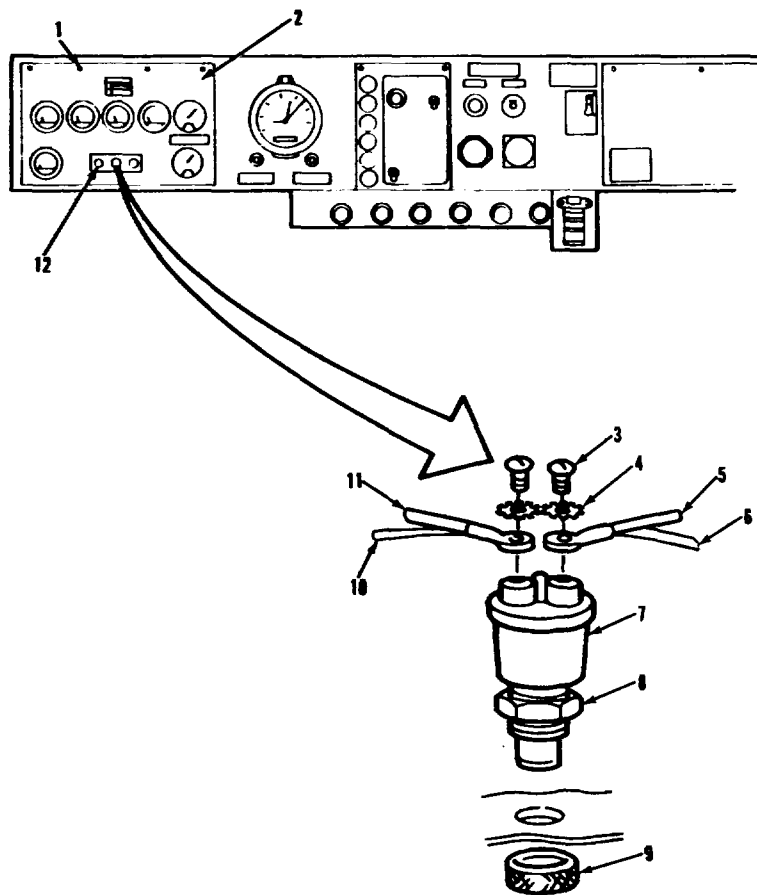

LEGEND:

- |                           |                              |
|---------------------------|------------------------------|
| 1. QUARTER-TURN SCREW (4) | 7. STARTER PUSHBUTTON SWITCH |
| 2. INSTRUMENT PANEL       | 8. ADJUSTING HEX NUT         |
| 3. SCREW (2)              | 9. KNURLED NUT               |
| 4. LOCKWASHER (2)         | 10. WIRE (98E)               |
| 5. WIRE (46)              | 11. WIRE (98F)               |
| 6. WIRE (55C)             | 12. IGNITION SWITCH          |

TA 237191

**ELECTRICAL SYSTEM.**

**3-75. PUSHBUTTON STARTER SWITCH REPLACEMENT (Continued).**

LOCATION/ITEM	ACTION	REMARKS
---------------	--------	---------

C. OPERATIONAL CHECK.

12. Panel (2).	Raise into place.	
13. Four screws (1).	Tighten.	
14. Batteries.	Connect.	Refer to paragraph 3-120.
15. Ignition switch (12).	Turn ON.	
16. Starter push-button switch (7).	Depress momentarily and observe that the starter motor engages.	

NOTE  
Follow-on maintenance action required:  
None.

ELECTRICAL SYSTEM.

3-75. PUSHBUTTON STARTER SWITCH REPLACEMENT (Continued).

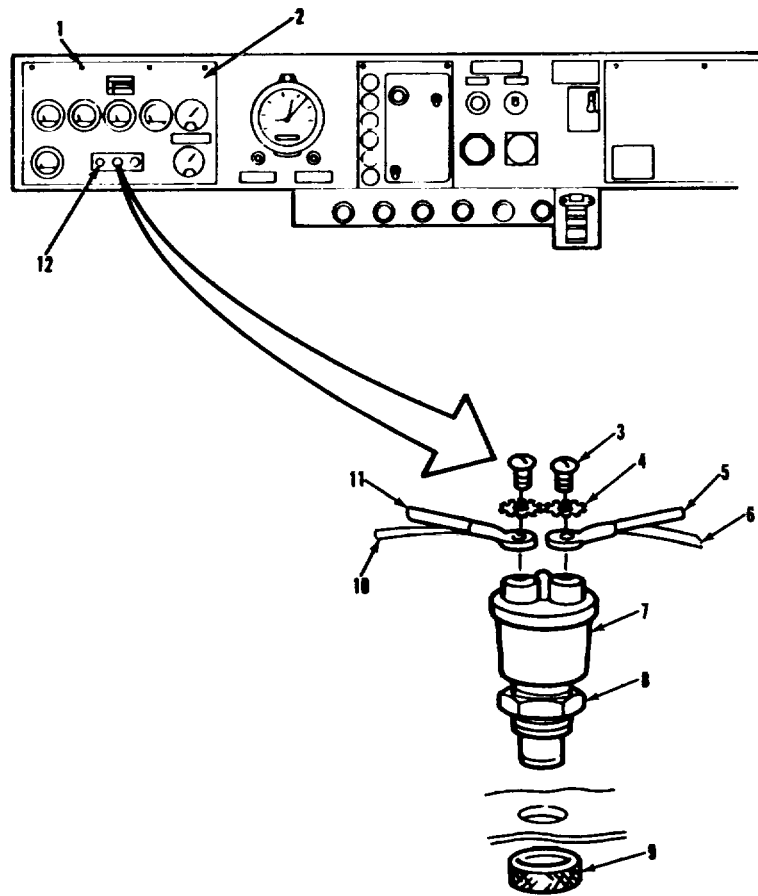

LEGEND:

- 1. QUARTER-TURN SCREW (4)
- 2. INSTRUMENT PANEL
- 3. SCREW (2)
- 4. LOCKWASHER (2)
- 5. WIRE (46)
- 6. WIRE (55C)

- 7. STARTER PUSHBUTTON SWITCH
- 8. ADJUSTING HEX NUT
- 9. KNURLED NUT
- 10. WIRE (98E)
- 11. WIRE (98F)
- 12. IGNITION SWITCH

TA 237192

**ELECTRICAL SYSTEM.**

**3-76. ETHER START SWITCH REPLACEMENT.**

THIS TASK COVERS

- a. Removal.
- b. Installation.
- c. Operational Check.

INITIAL SETUP

EQUIPMENT CONDITION

<u>APPLICABLE CONFIGURATIONS</u>	<u>PARAGRAPH</u>	<u>CONDITION DESCRIPTION</u>
All. disconnected.	3-120.	Battery power

TEST EQUIPMENT

None.

SPECIAL TOOLS

None.

MATERIALS/PARTS (P/N)

None.

PERSONNEL REQUIRED

One (MOS-63S).

REFERENCES (TM)

TM 9-2320-283-10.

SPECIAL ENVIRONMENTAL CONDITIONS

Vehicle parked on level ground.

GENERAL SAFETY INSTRUCTIONS

Engine off.

Transmission in neutral.

Park brake set.

TROUBLESHOOTING REFERENCES

Paragraph 2-11.

ELECTRICAL SYSTEM.

3-76. ETHER START SWITCH REPLACEMENT (Continued).

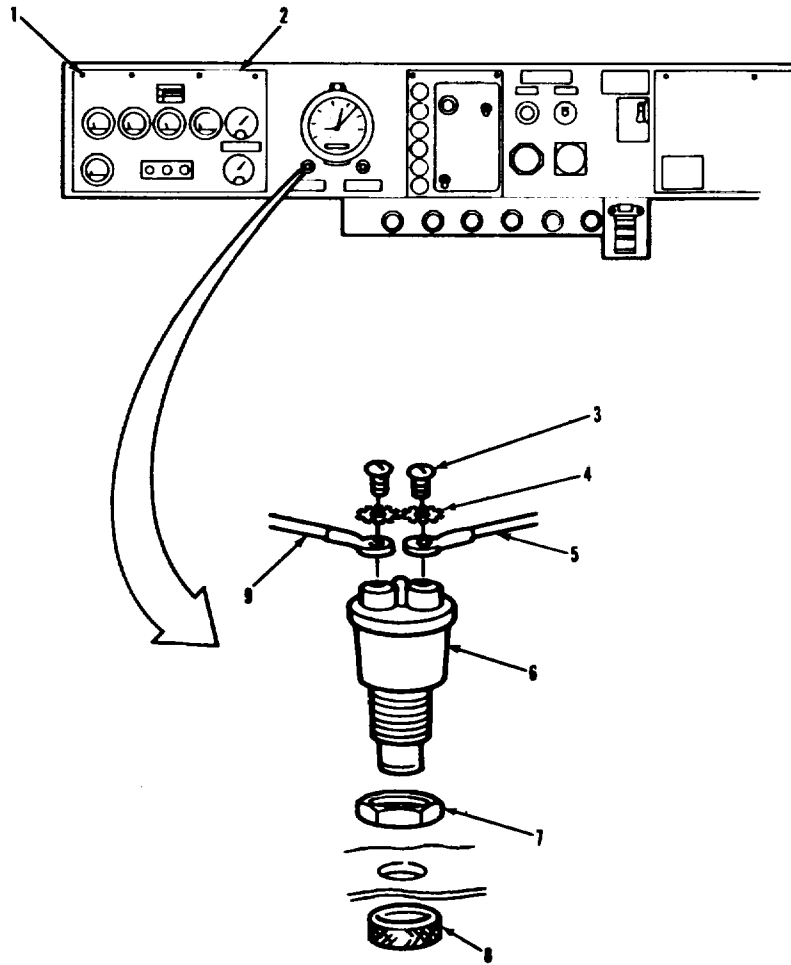

LEGEND:

- 1. QUARTER-TURN SCREW
- 2. INSTRUMENT PANEL
- 3. SCREW (2)
- 4. LOCKWASHER (2)
- 5. WIRE (51A)

- 6. ETHER START SWITCH
- 7. HEX NUT
- 8. KNURLED NUT
- 9. WIRE (51)

TA 237193

**ELECTRICAL SYSTEM.**

**3-76. ETHER START SWITCH REPLACEMENT (Continued).**

LOCATION/ITEM	ACTION	REMARKS
---------------	--------	---------

**A. REMOVAL.**

- |  |                                |                       |
|--|--------------------------------|-----------------------|
| 1. Four screws (1).  | Loosen.                        |                       |
| 2. Panel (2).  | Lower.                         |                       |
| 3. Knurled nut (8).  | Remove.                        |                       |
| 4. Switch (6).   | Remove.                        |                       |
| 5. Two screws (3), lockwashers (4), and wires (5) and (9). | Remove.<br>for identification. | Tag items (5) and (9) |
| 6. Hex nut (7).  | Remove.                        |                       |

**B. INSTALLATION.**

- |   |                      |   |
|---|----------------------|---|
| 7. Wires (5) and (9), two screws (3), and lockwashers (4).    | Install.             | Connect according to identification tags from step 5. |
| 8. Hex nut (7) on item (6) to allow installation of item (8). | Install.             | Adjust to proper depth                                |
| 9. Switch (6).  | Install in item (2). |   |
| 10. Knurled nut (8).  | Install and tighten. |   |
| 11. Panel (2).  | Raise into place.    |   |
| 12. Four screws (1).  | Tighten.             |   |
| 13. Batteries.  | Connect.             | Refer to paragraph 3-120.                             |

**C. OPERATIONAL CHECK.**

- |             |                                      |                            |
|-------------|--------------------------------------|----------------------------|
| 14. Engine. | Start up using cold start procedure. | Refer to TM 9-2320-283-10. |
|-------------|--------------------------------------|----------------------------|

**NOTE**

Follow-on maintenance action required:  
None.

ELECTRICAL SYSTEM.

3-76. ETHER START SWITCH REPLACEMENT (Continued).

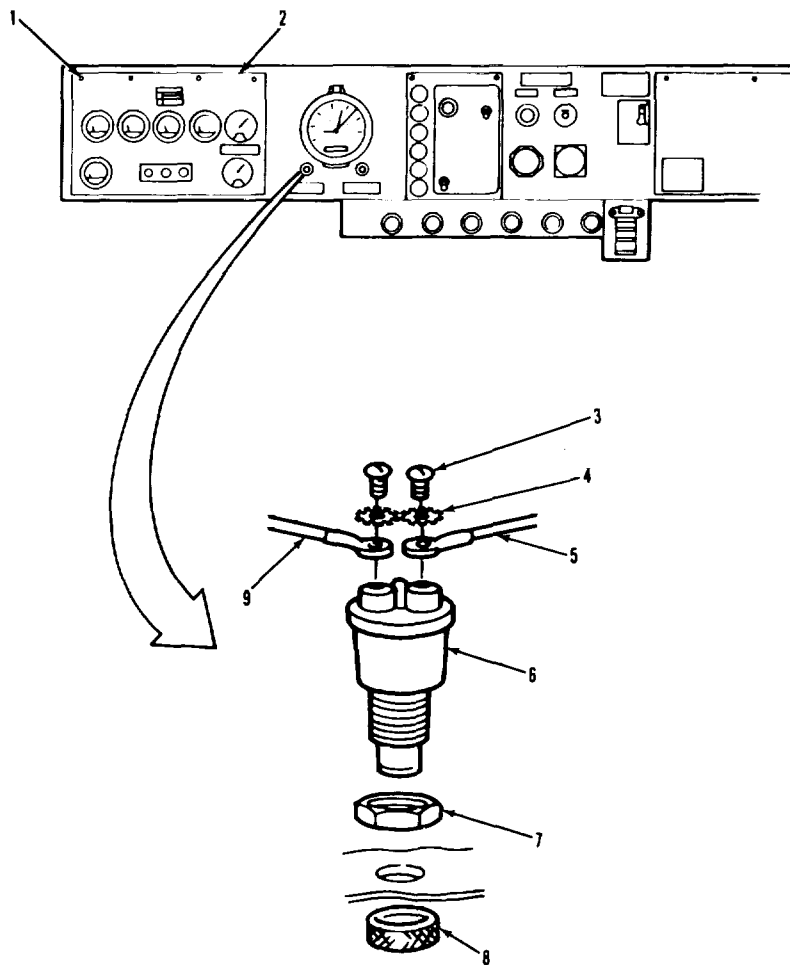

LEGEND:

- 1. QUARTER-TURN SCREW
- 2. INSTRUMENT PANEL
- 3. SCREW (2)
- 4. LOCKWASHER (2)
- 5. WIRE (51A)

- 6. ETHER START SWITCH
- 7. HEX NUT
- 8. KNURLED NUT
- 9. WIRE (51)

TA 237194

**3-77. PUSHBUTTON CLEARANCE LAMP SWITCH REPLACEMENT.**

THIS TASK COVERS

- a. Removal.
- b. Installation.
- c. Operational Check.

INITIAL SETUP

<u>APPLICABLE CONFIGURATIONS</u>	<u>EQUIPMENT CONDITION</u> <u>PARAGRAPH</u>	<u>CONDITION DESCRIPTION</u>
All. 3-120. disconnected.	Battery power	
<u>TEST EQUIPMENT</u>		
None.		
<u>SPECIAL TOOLS</u>		
None.		
<u>MATERIALS/PARTS (P/N)</u>		
None.		
<u>PERSONNEL REQUIRED</u>	<u>SPECIAL ENVIRONMENTAL CONDITIONS</u>	
One (MOS-63S).	Vehicle parked on level ground.	
<u>REFERENCES (TM)</u>	<u>GENERAL SAFETY INSTRUCTIONS</u>	
TM 9-2320-283-10.	Engine off.	
	Transmission in neutral.	
	Park brake set.	
<u>TROUBLESHOOTING REFERENCES</u>		
Paragraph 2-11.		



ELECTRICAL SYSTEM.

3-77. PUSHBUTTON CLEARANCE LAMP SWITCH REPLACEMENT (Continued).

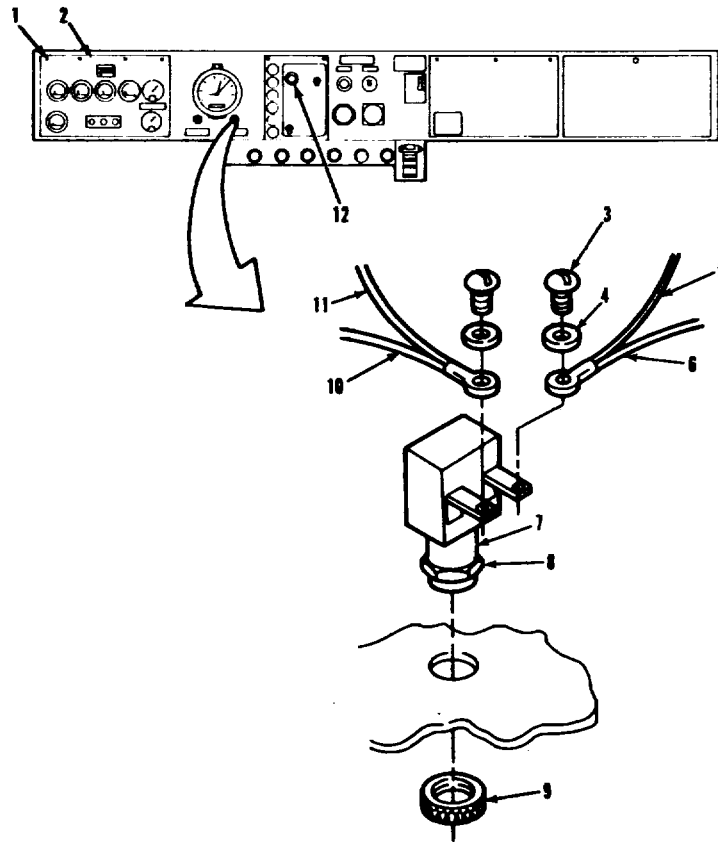

LEGEND:

- |                           |                                     |
|---------------------------|-------------------------------------|
| 1. QUARTER-TURN SCREW (4) | 7. PUSHBUTTON CLEARANCE LAMP SWITCH |
| 2. INSTRUMENT PANEL       | 8. ADJUSTING HEX NUT                |
| 3. SCREW (2)              | 9. KNURLED NUT                      |
| 4. LOCKWASHER (2)         | 10. WIRE (30P)                      |
| 5. WIRE (31B)             | 11. WIRE (30N)                      |
| 6. WIRE (31)              | 12. HEADLAMP SWITCH                 |

TA 237195

**ELECTRICAL SYSTEM.**

**3-77. PUSHBUTTON CLEARANCE LAMP SWITCH REPLACEMENT (Continued).**

LOCATION/ITEM	ACTION	REMARKS
<b>A. REMOVAL.</b>		
1. Four screws (1).	Loosen.	
2. Instrument panel (2).	Lower.	
3. Two screws (3) and lockwashers (4).	Remove.	
4. Wire (5), (6), (10), and (11).	Remove.	Tag for identification. Items (5) and (6) share a common terminal. Items (10) and (11) share a common terminal.
5. Knurled nut (9).	Remove.	
6. Pushbutton clearance lamp switch (7).	Remove.	
7. Nut (8).	Remove.	
<b>B. INSTALLATION</b>		
8. Nut (8).	Install and adjust to proper depth on item (7) to allow installation of item (9).	
9. Pushbutton clearance lamp (7).	Install.	
10. Knurled nut (9).	Install and tighten.	
11. Wires (5), (6), (10), and (11), two screws (3) and lockwashers (4).	a. Install.  b. Tighten two items (3).	Connect according to identification tag from step 4.

ELECTRICAL SYSTEM.

3-77. PUSHBUTTON CLEARANCE LAMP SWITCH REPLACEMENT (Continued).

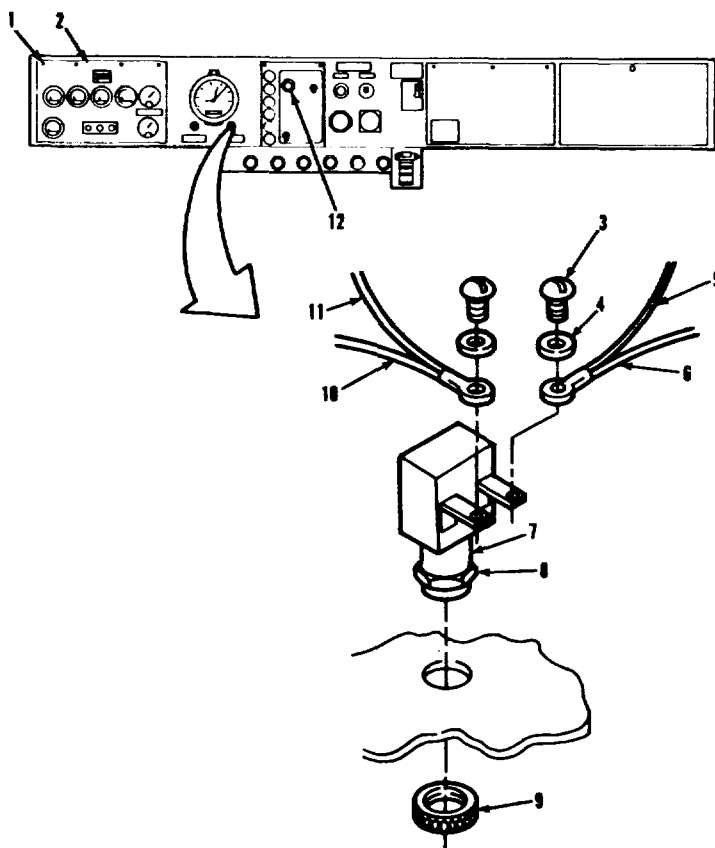

LEGEND:

- |                           |                                     |
|---------------------------|-------------------------------------|
| 1. QUARTER-TURN SCREW (4) | 7. PUSHBUTTON CLEARANCE LAMP SWITCH |
| 2. INSTRUMENT PANEL       | 8. ADJUSTING HEX NUT                |
| 3. SCREW (2)              | 9. KNURLED NUT                      |
| 4. LOCKWASHER (2)         | 10. WIRE (30P)                      |
| 5. WIRE (31B)             | 11. WIRE (30N)                      |
| 6. WIRE (31)              | 12. HEADLAMP SWITCH                 |

TA 237196

ELECTRICAL SYSTEM.

**3-77. PUSHBUTTON CLEARANCE LAMP SWITCH REPLACEMENT (Continued).**

LOCATION/ITEM	ACTION	REMARKS
---------------	--------	---------

**B. INSTALLATION (Continued).**

12. Instrument panel (2)	Raise into position.	
13. Four screws (4).	Tighten.	
14. Batteries. 3-120.	Connect.	Refer to paragraph

**C. OPERATIONAL CHECK.**

15. Headlamp switch (12).	Pull out to turn on. 10.	Refer to TM 9-2320-283-10.
16. Pushbutton clearance lamp switch (7).	Press.	Verify that truck and trailer clearance lamps go off. (Refer to TM 9-2320-283-10).

NOTE  
Follow-on maintenance action required:  
None.

ELECTRICAL SYSTEM.

3-77. PUSHBUTTON CLEARANCE LAMP SWITCH REPLACEMENT (Continued).

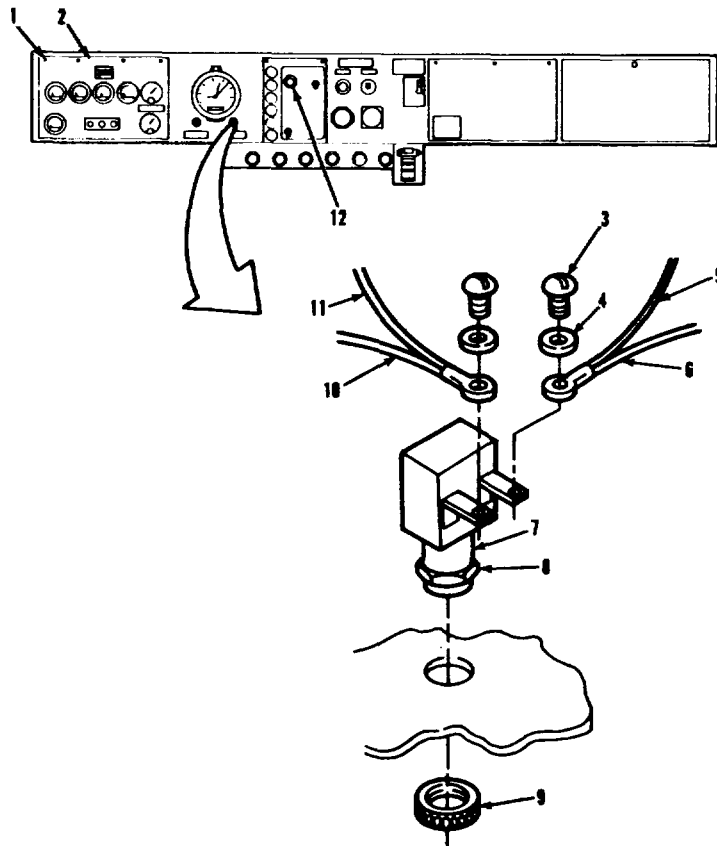

LEGEND:

- |                           |                                     |
|---------------------------|-------------------------------------|
| 1. QUARTER-TURN SCREW (4) | 7. PUSHBUTTON CLEARANCE LAMP SWITCH |
| 2. INSTRUMENT PANEL       | 8. ADJUSTING HEX NUT                |
| 3. SCREW (2)              | 9. KNURLED NUT                      |
| 4. LOCKWASHER (2)         | 10. WIRE (30P)                      |
| 5. WIRE (31B)             | 11. WIRE (30N)                      |
| 6. WIRE (31)              | 12. HEADLAMP SWITCH                 |

TA 237196

**ELECTRICAL SYSTEM.**

**3-78. HEADLAMP SWITCH REPLACEMENT.**

THIS TASK COVERS

- a. Removal.
- b. Installation.
- c. Operational Check.

INITIAL SETUP

EQUIPMENT CONDITION

<u>APPLICABLE CONFIGURATIONS</u>	<u>PARAGRAPH</u>
----------------------------------	------------------

All.	3-120.
------	--------

CONDITION DESCRIPTION

Battery power disconnected.

TEST EQUIPMENT

None.

SPECIAL TOOLS

None.

MATERIALS/PARTS (P/N)

Tie, cable

(06383) SST4S.

PERSONNEL REQUIRED

One (MOS-63S).

REFERENCES (TM)

IM 9-2320-283-10.

Transmission in neutral.

Park brake set.

TROUBLESHOOTING REFERENCES

Paragraph 2-11.

SPECIAL ENVIRONMENTAL CONDITIONS

Vehicle parked on level ground.

GENERAL SAFETY INSTRUCTIONS

Engine off.

ELECTRICAL SYSTEM.

3-78. HEADLAMP SWITCH REPLACEMENT (Continued).

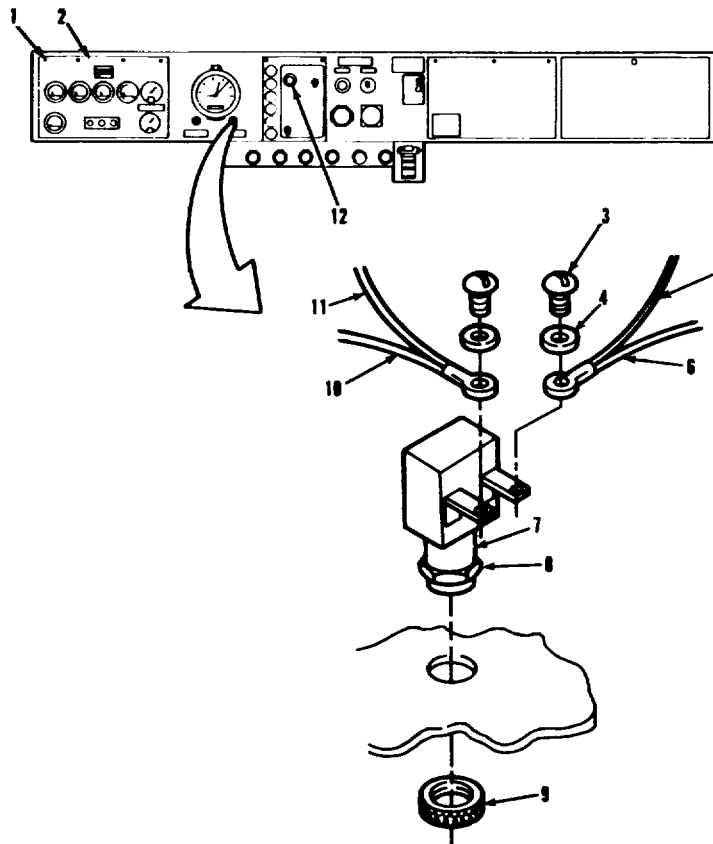

LEGEND:

- |                           |                                     |
|---------------------------|-------------------------------------|
| 1. QUARTER-TURN SCREW (4) | 7. PUSHBUTTON CLEARANCE LAMP SWITCH |
| 2. INSTRUMENT PANEL       | 8. ADJUSTING HEX NUT                |
| 3. SCREW (2)              | 9. KNURLED NUT                      |
| 4. LOCKWASHER (2)         | 10. WIRE (30P)                      |
| 5. WIRE (31B)             | 11. WIRE (30N)                      |
| 6. WIRE (31)              | 12. HEADLAMP SWITCH                 |

TA 237197

**ELECTRICAL SYSTEM.**

**3-78. HEADLAMP SWITCH REPLACEMENT (Continued).**

LOCATION/ITEM	ACTION	REMARKS
<b>A. REMOVAL.</b>		
1. Two screws (1).	Loosen.	
2. Panel (2).	Lower	
3. Release button (7).	Push and hold.	
4. Knob and control rod (4).	Pull out and remove.	
5. Hex nut (5).	Remove.	
6. Switch (6).	Remove.	
7. Cable tie (8).	Cut and remove.	
8. Connector (3).	Remove from item (6).	Disengage two molded clips from side of item (6), and remove item (3).
<b>B. INSTALLATION.</b>		
9. Connector (3).	Install on item (6).	Snap molded clips around side of item (6) to secure item (3) in place.
10. New cable tie (8).	Wrap around items (6) and (3) and secure in place.	Trim off excess length of item (8).
11. Switch (6).	Install.	
12. Hex nut (5).	Install and tighten.	
13. Knob and control rod (4).	Install. felt and item (4) locks	Push in until click is into place.
14. Panel (2).	Raise into place.	
15. Two screws (1).	Tighten.	



ELECTRICAL SYSTEM.

3-78. HEADLAMP SWITCH REPLACEMENT (Continued).

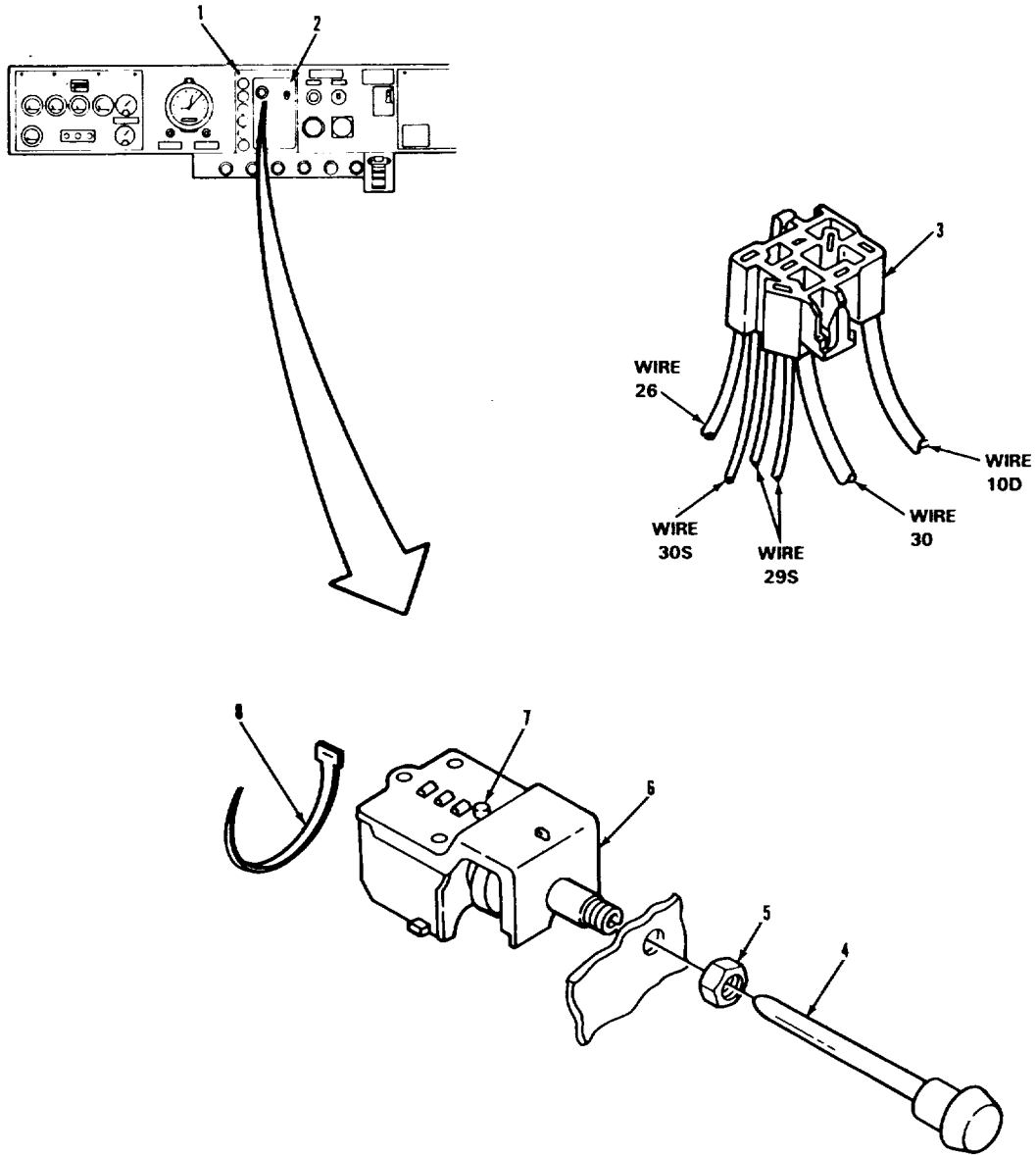

LEGEND:

- 1. QUARTER-TURN SCREW (2)
- 2. INSTRUMENT PANEL
- 3. CONNECTOR
- 4. KNOB AND CONTROL ROD

- 5. HEX NUT
- 6. HEADLAMP SWITCH
- 7. RELEASE BUTTON
- 8. CABLE TIE

TA 237198

ELECTRICAL SYSTEM.

3-78. HEADLAMP SWITCH REPLACEMENT (Continued).		
LOCATION/ITEM	ACTION	REMARKS
B. INSTALLATION (Continued).		
16. Batteries.	Connect.	Refer to paragraph 3-120.
C. OPERATIONAL TEST.		
17 Headlamp switch (6).	<ul style="list-style-type: none"> <li>a. Pull out to first position.</li> <li>b. Pull out to second position.</li> <li>c. Rotate.</li> </ul>	<ul style="list-style-type: none"> <li>Verify that parking and clearance lamps operate. (Refer to TM 9-2320-283-10).</li> <li>Verify that headlamps operate along with parking and clearance lamps.</li> <li>Verify that gage lamps dim and brighten.</li> </ul>
<p>NOTE</p> <p>Follow-on' maintenance action required: None.</p>		
<p><b>3-450</b></p>		

ELECTRICAL SYSTEM.

3-78. HEADLAMP SWITCH REPLACEMENT (Continued).

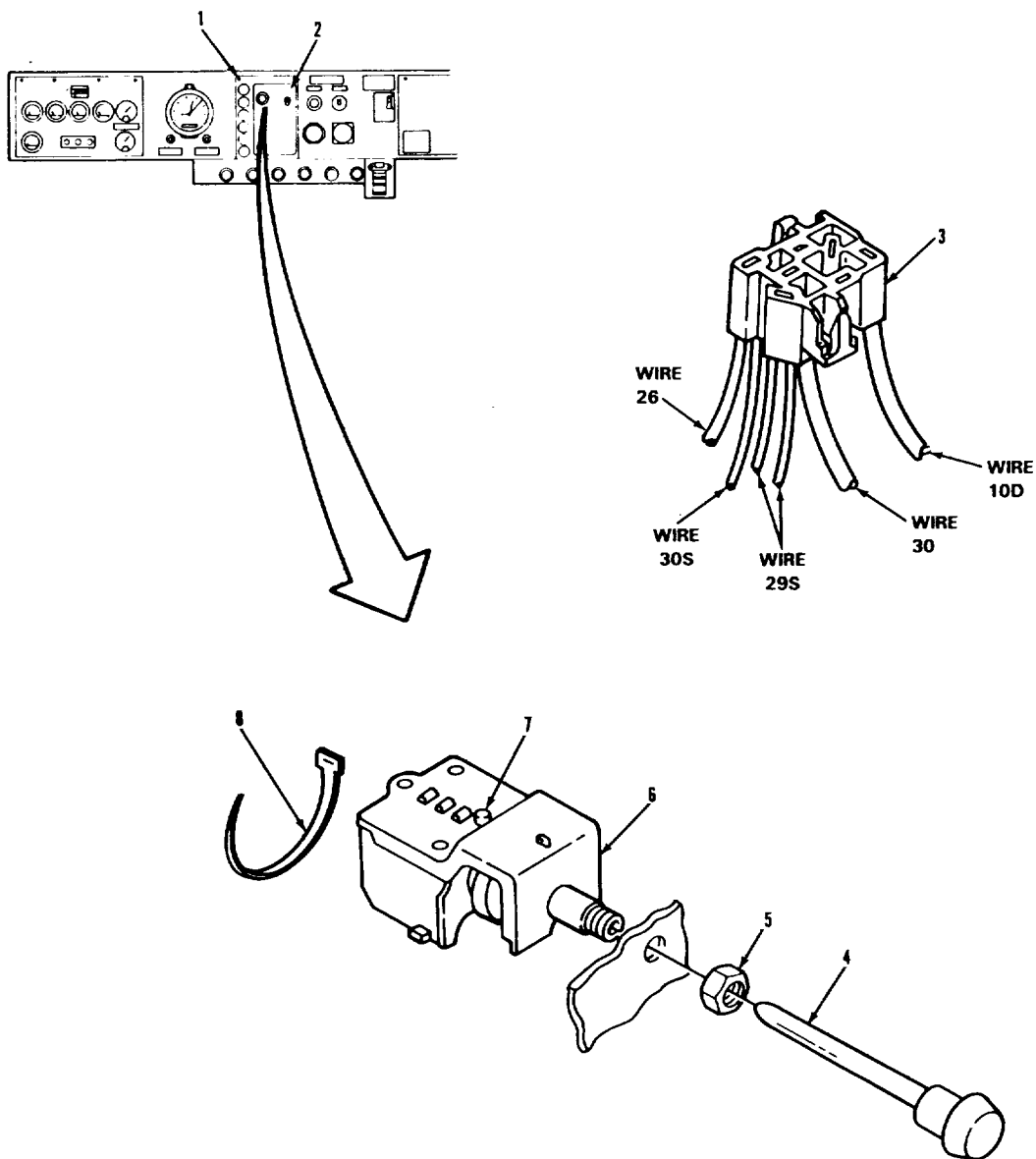

LEGEND:

- 1. QUARTER-TURN SCREW (2)
- 2. INSTRUMENT PANEL
- 3. CONNECTOR
- 4. KNOB AND CONTROL ROD

- 5. HEX NUT
- 6. HEADLAMP SWITCH
- 7. RELEASE BUTTON
- 8. CABLE TIE

TA 237198

**ELECTRICAL SYSTEM.**

**3-79. BLACKOUT TOGGLE SWITCH REPLACEMENT.**

THIS TASK COVERS

- a. Removal.
- b. Installation.
- c. Operational Check.

INITIAL SETUP

<u>APPLICABLE CONFIGURATIONS</u>	<u>EQUIPMENT CONDITION PARAGRAPH</u>	<u>CONDITION DESCRIPTION</u>
All. 3-120.		Battery power disconnected.

TEST EQUIPMENT

None.

SPECIAL TOOLS

None.

MATERIALS/PARTS (P/N)

None.

PERSONNEL REQUIRED

One (MOS-63S).

REFERENCES (TM)

TM 9-2320-283-10.

SPECIAL ENVIRONMENTAL CONDITIONS

Vehicle parked on level ground.

GENERAL SAFETY INSTRUCTIONS

Engine off.

Transmission in neutral.

Park brake set.

TROUBLESHOOTING REFERENCES

Paragraph 2-11.

ELECTRICAL SYSTEM.

3-79. BLACKOUT TOGGLE SWITCH REPLACEMENT (Continued).

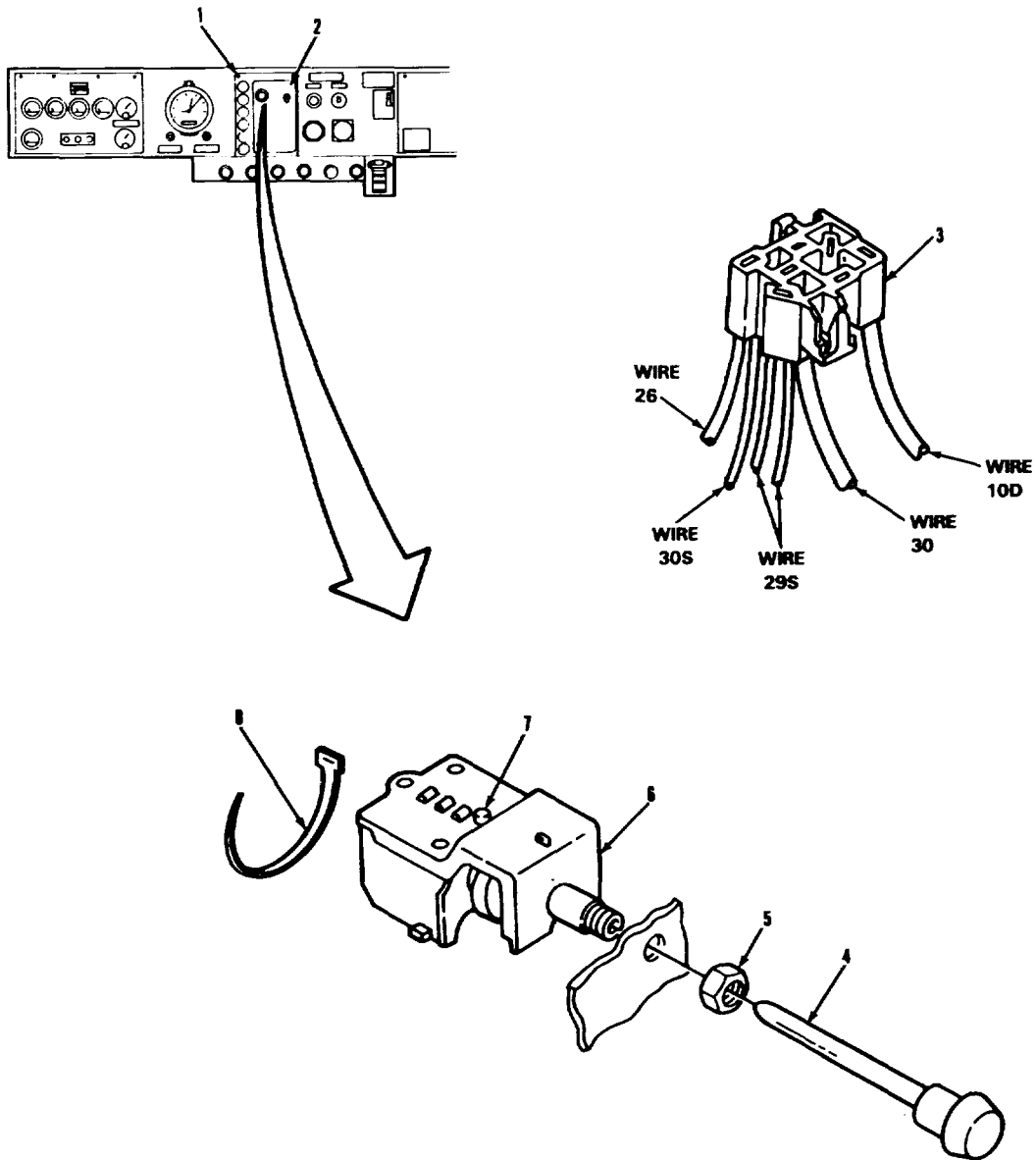

LEGEND:

- 1. QUARTER-TURN SCREW (2)
- 2. INSTRUMENT PANEL
- 3. CONNECTOR
- 4. KNOB AND CONTROL ROD

- 5. HEX NUT
- 6. HEADLAMP SWITCH
- 7. RELEASE BUTTON
- 8. CABLE TIE

TA 237199

**ELECTRICAL SYSTEM.**

**3-79. BLACKOUT TOGGLE SWITCH REPLACEMENT (Continued).**

LOCATION/ITEM	ACTION	REMARKS
A. REMOVAL. I		
1. Two screws (1).	Loosen.	
2. Panel (2).	Lower.	
3. Hex nut (13) and lockwasher (12).	Remove.	
4. Blackout toggle switch (14).	Remove.	Push through item (2).
5. Twelve screws (16), twelve lockwashers (15), wires (3), (4), (5), (6), (7), (8), (9), (10), (11), (17), (18), and (19).	Remove.	Tag wires for identification.
B. INSTALLATION.		
6. Twelve screws (16), twelve lockwashers (15), wires (3), (4), (5), (6), (7), (8), (9), (10), (11), (17), (18), and (19).	Install.	Connect according to identification tag from step 5.
7. Blackout toggle switch (14).	Install.	Make sure that item (14) can be operated in up and down position prior to mounting.
8. Hex nut (13) and lockwasher (12).	Install and tighten.	

**ELECTRICAL SYSTEM.**

**3-79. BLACKOUT TOGGLE SWITCH REPLACEMENT (Continued).**

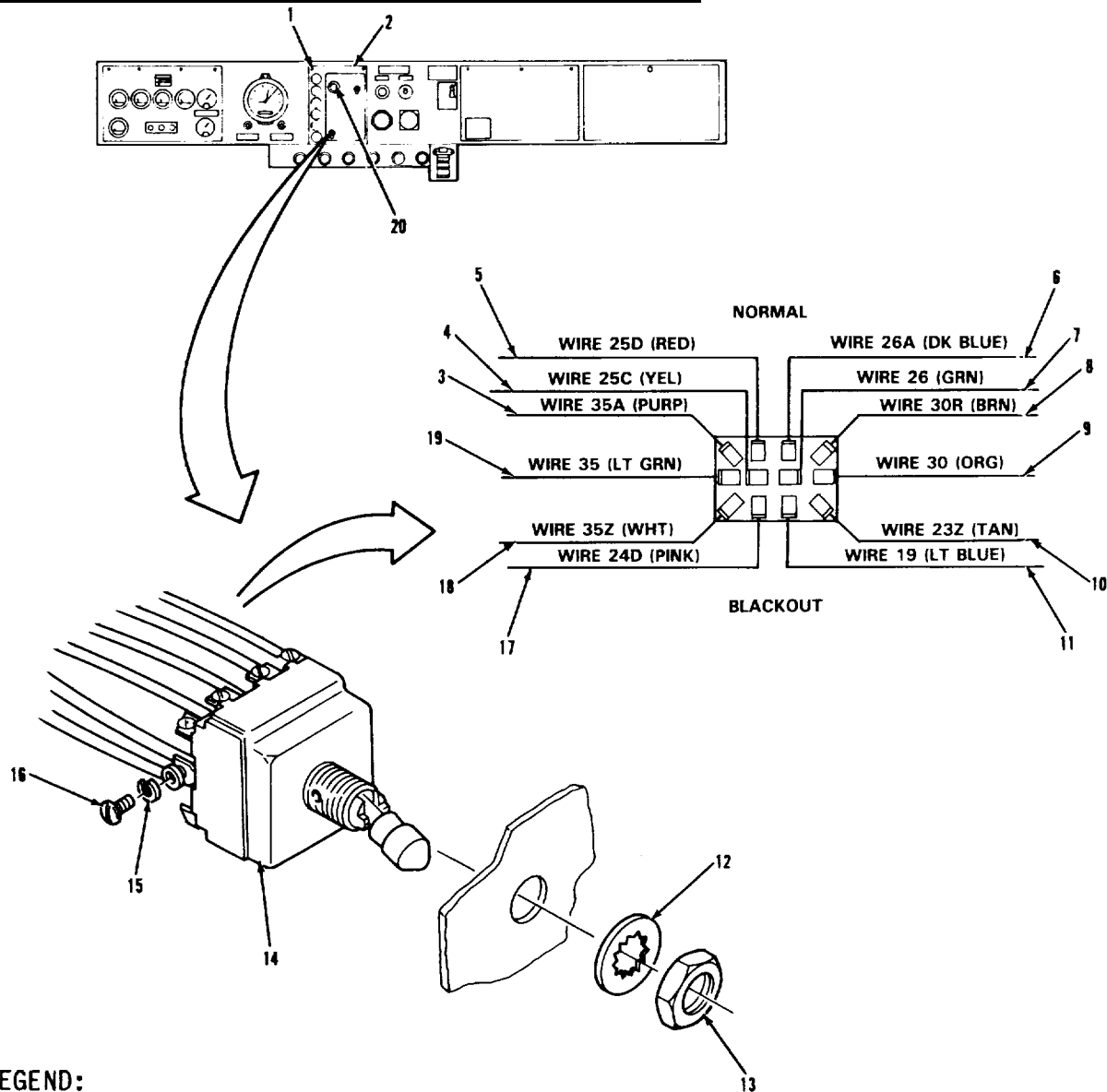

**LEGEND:**

- |                           |                            |
|---------------------------|----------------------------|
| 1. QUARTER-TURN SCREW (2) | 11. WIRE (19)              |
| 2. INSTRUMENT PANEL       | 12. LOCKWASHER             |
| 3. WIRE (35A)             | 13. HEX NUT                |
| 4. WIRE (25C)             | 14. BLACKOUT TOGGLE SWITCH |
| 5. WIRE (25D)             | 15. LOCKWASHER (12)        |
| 6. WIRE (26A)             | 16. SCREW (12)             |
| 7. WIRE (26)              | 17. WIRE (24D)             |
| 8. WIRE (30R)             | 18. WIRE (35Z)             |
| 9. WIRE (30)              | 19. WIRE (35)              |
| 10. WIRE (23Z)            | 20. HEADLAMP SWITCH        |

TA 237202

**ELECTRICAL SYSTEM.**

**3-79. BLACKOUT TOGGLE SWITCH REPLACEMENT (Continued).**

LOCATION/ITEM	ACTION	REMARKS
<b>B. INSTALLATION (Continued).</b>		
9. Panel (2).	Raise into position.	
10. Two screws (1).	Tighten.	
11. Batteries.	Connect.	Refer to paragraph 3-120.
<b>C. OPERATIONAL CHECK.</b>		
12. Blackout toggle switch (14).	a. Set to normal.	Pull out item (20). Verify that all lamps operate. (Refer to TM 9-2320-283-10).
	b. Set to blackout.	Verify correct operation. (Refer to TM 9-2320-283-10).
<p><b>NOTE</b>                      Follow-on maintenance action required:                      None.</p>		
<p><b>3-456</b></p>		



ELECTRICAL SYSTEM.

3-79. BLACKOUT TOGGLE SWITCH REPLACEMENT (Continued).

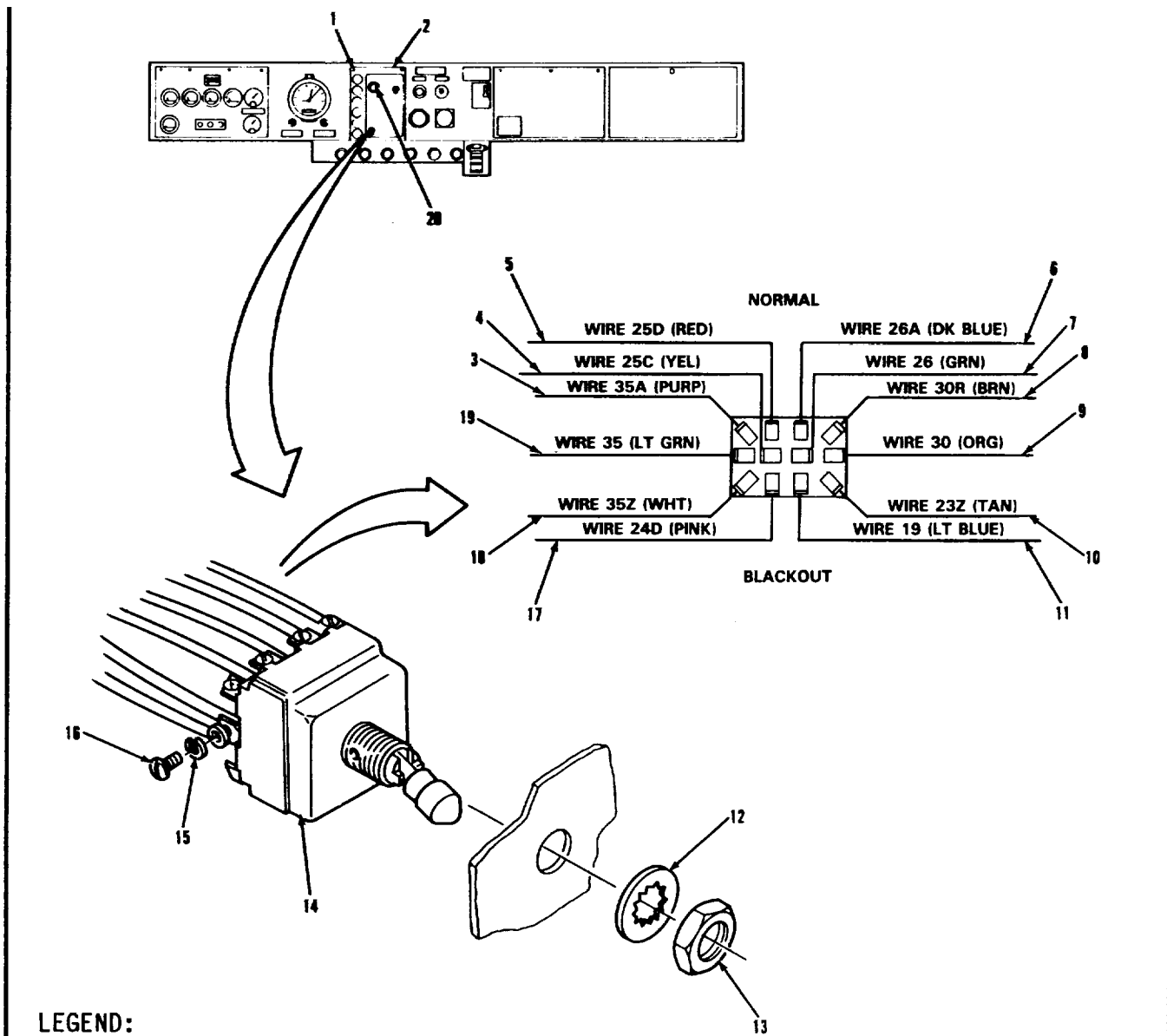

LEGEND:

- |                           |                            |
|---------------------------|----------------------------|
| 1. QUARTER-TURN SCREW (2) | 11. WIRE (19)              |
| 2. INSTRUMENT PANEL       | 12. LOCKWASHER             |
| 3. WIRE (35A)             | 13. HEX NUT                |
| 4. WIRE (25C)             | 14. BLACKOUT TOGGLE SWITCH |
| 5. WIRE (25D)             | 15. LOCKWASHER (12)        |
| 6. WIRE (26A)             | 16. SCREW (12)             |
| 7. WIRE (26)              | 17. WIRE (24D)             |
| 8. WIRE (30R)             | 18. WIRE (35Z)             |
| 9. WIRE (30)              | 19. WIRE (35)              |
| 10. WIRE (23Z)            | 20. HEADLAMP SWITCH        |

TA 237203

**ELECTRICAL SYSTEM.**

**3-80. TURN SIGNAL SWITCH REPLACEMENT.**

**THIS TASK COVERS**

- |                 |                       |
|-----------------|-----------------------|
| a. Removal.     | d. Installation.      |
| b. Disassembly. | e. Operational Check. |
| c. Assembly.    |                       |

INITIAL SETUP

APPLICABLE CONFIGURATIONS

All.

EQUIPMENT CONDITION

PARAGRAPH

None.

CONDITION DESCRIPTION

None.

TEST EQUIPMENT

None.

SPECIAL TOOLS

None.

MATERIALS/PARTS (P/N)

None.

PERSONNEL REQUIRED

One (MOS-63S).

SPECIAL ENVIRONMENTAL CONDITIONS

Vehicle parked on level ground.

REFERENCES (TM)

TM 9-2320-283-10.

GENERAL SAFETY INSTRUCTIONS

Engine off.  
Transmission in neutral.  
Park brake set.

TROUBLESHOOTING REFERENCES

Paragraph 2-11.

ELECTRICAL SYSTEM.

3-80. TURN SIGNAL SWITCH REPLACEMENT (Continued).

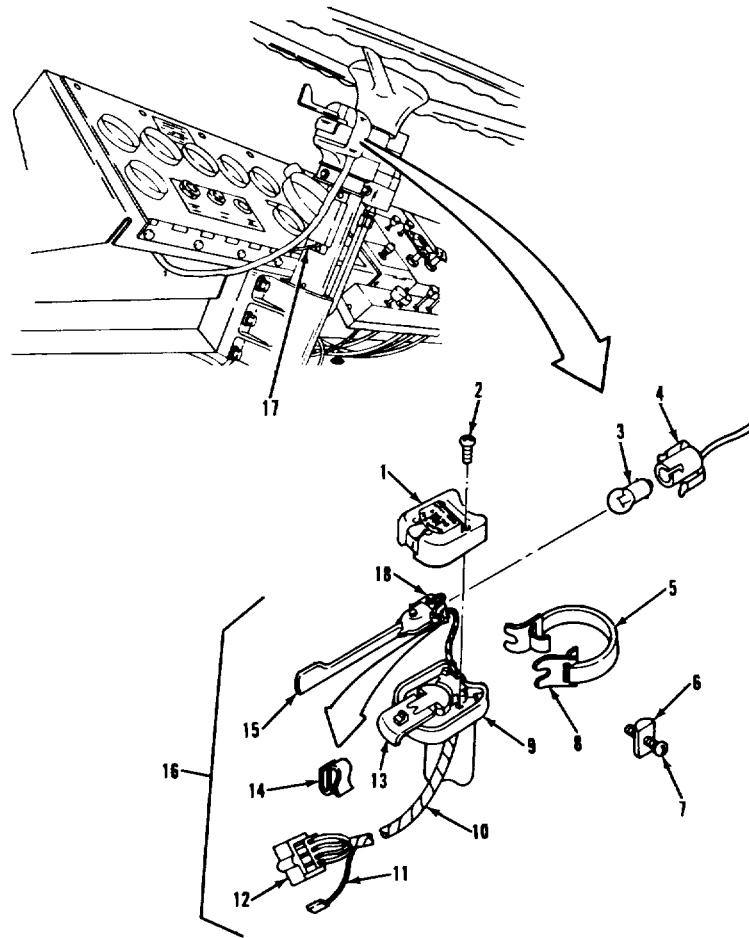

LEGEND:

- |               |                                 |
|---------------|---------------------------------|
| 1. COVER      | 10. HARNESS                     |
| 2. SCREW (2)  | 11. TERMINAL (7)                |
| 3. BULB       | 12. CONNECTOR                   |
| 4. SOCKET     | 13. HAZARD SWITCH ACTUATOR      |
| 5. STRAP      | 14. SPRING CLIP                 |
| 6. ANCHOR (2) | 15. HANDLE                      |
| 7. SCREW (2)  | 16. TURN SIGNAL SWITCH ASSEMBLY |
| 8. CLIP (2)   | 17. WIRE (41C)                  |
| 9. SWITCH     | 18. PIN                         |

TA 237204

**ELECTRICAL SYSTEM.**

**3-80. TURN SIGNAL SWITCH REPLACEMENT (Continued).**

LOCATION/ITEM	ACTION	REMARKS
---------------	--------	---------

**NOTE**

If only bulb is to be replaced, do steps 5, 6, 7, 8, 9, 10, 14, 15, 16, 18, 19, and 20

**A. REMOVAL.**

- |  |   |  |
|--|---|--|
| 1. Connector (12).   | Remove from mating connector under instrument panel.  |  |
| 2. Wire (17).  | Remove from item (10) bundle. Unwrap electrical tape. |  |
| 3. Two screws (7) and two anchors (6).                             | Remove.   |  |
| 4. Turn signal switch assembly (16), strap (5), and two clips (8). | Remove.   |  |

**B. DISASSEMBLY**

- |                                  |                       |   |
|----------------------------------|-----------------------|---|
| 5. Two screws (2).               | Remove.               |   |
| 6. Cover (1).                    | Remove.               |   |
| 7. Handle (15).                  | Remove.               | Item (15) has lead from Item (4) attached.          |
| 8. Spring clip (14).             | Remove.               |   |
| 9. Bulb (3) and socket (4).      | Remove.               |   |
| 10. Bulb (3).                    | Remove from item (4). | Push in and turn counterclockwise one quarter turn. |
| 11. Hazard switch actuator (13). | Remove.               |   |
| 12. Seven terminals (11).        | Remove from item (12) | Tag for identification.                             |

ELECTRICAL SYSTEM.

3-80. TURN SIGNAL SWITCH REPLACEMENT (Continued).

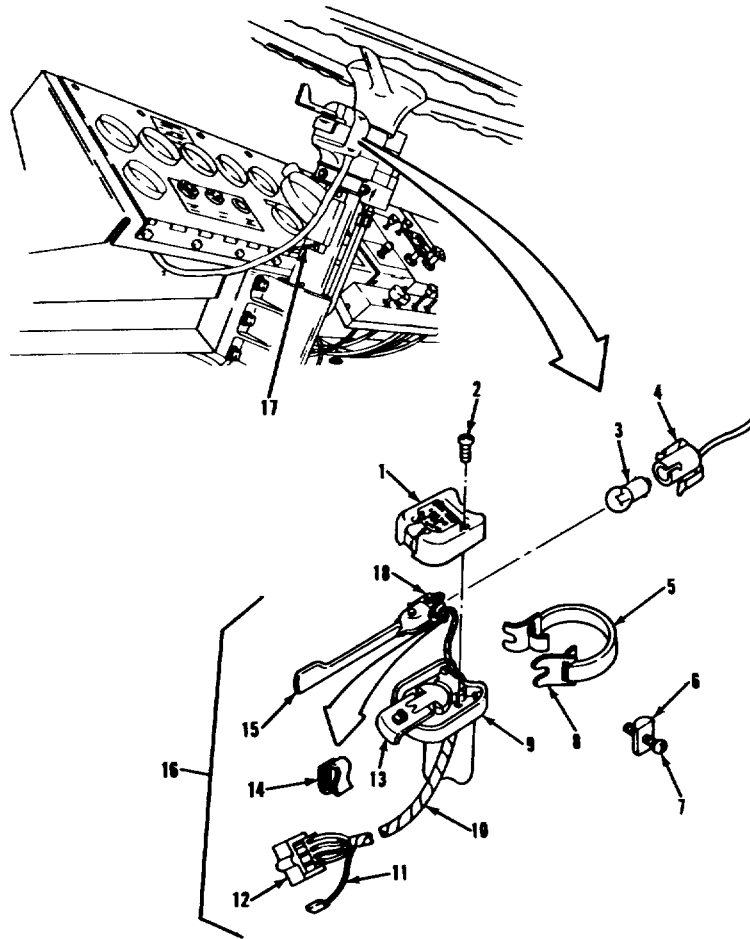

LEGEND:

- |               |                                 |
|---------------|---------------------------------|
| 1. COVER      | 10. HARNESS                     |
| 2. SCREW (2)  | 11. TERMINAL (7)                |
| 3. BULB       | 12. CONNECTOR                   |
| 4. SOCKET     | 13. HAZARD SWITCH ACTUATOR      |
| 5. STRAP      | 14. SPRING CLIP                 |
| 6. ANCHOR (2) | 15. HANDLE                      |
| 7. SCREW (2)  | 16. TURN SIGNAL SWITCH ASSEMBLY |
| 8. CLIP (2)   | 17. WIRE (41C)                  |
| 9. SWITCH     | 18. PIN                         |

TA 237205

## ELECTRICAL SYSTEM.

**3-80. TURN SIGNAL SWITCH REPLACEMENT (Continued).**

LOCATION/ITEM	ACTION	REMARKS
C. ASSEMBLY.		
13. Seven terminals (11).	Install in item (12).	Connect according to identification tag from step 12.
14. Bulb (3).	Install in item (4).	Push in and turn one quarter turn clockwise.
15. Spring clip (14).	Install on side of item (4).	Make sure lead from item (4) is secured inside item (14).
16. Bulb (3) and socket (4).	Install in item (15).	
17. Hazard switch actuator (13).	Place over pin and press down.	
18. Handle (15).	Install.	Use item (4) end of item (15) to push in on spring loaded hazard switch.
19. Cover (1).	Place in position. Aline item (18) with hole on underside of item (1).	
<b>CAUTION</b> Switch body and cover are made of aluminum. Do not overtighten screws that fasten cover to switch body. Failure to heed caution will result in damage to switch body.		
20. Two screws (2).	Install and tighten.	Do not overtighten.

ELECTRICAL SYSTEM.

3-80. TURN SIGNAL SWITCH REPLACEMENT (Continued).

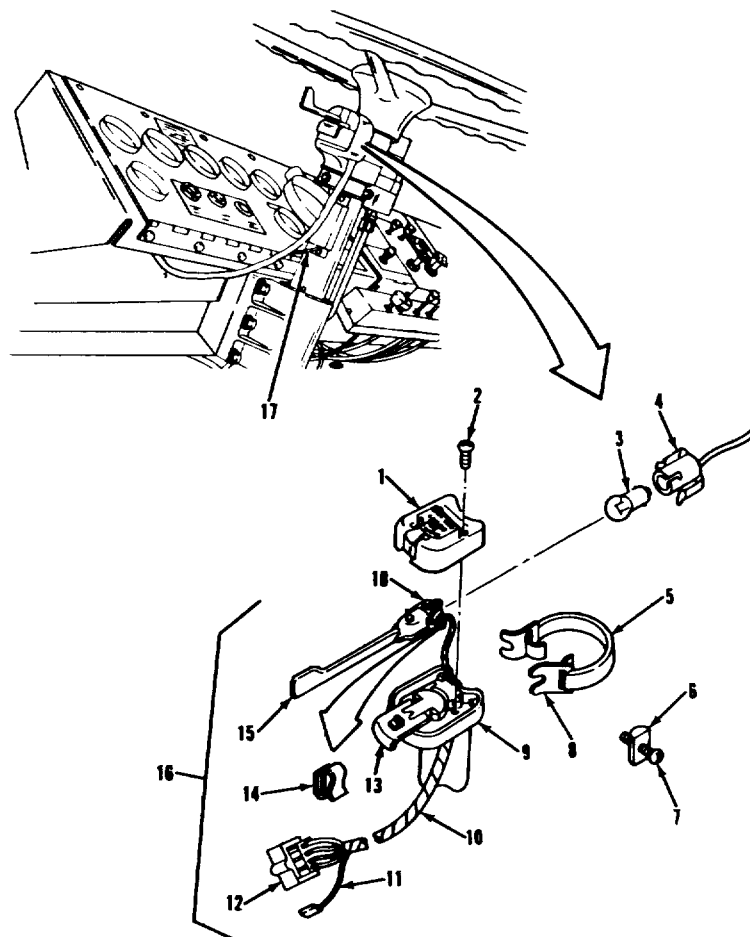

LEGEND:

- |               |                                 |
|---------------|---------------------------------|
| 1. COVER      | 10. HARNESS                     |
| 2. SCREW (2)  | 11. TERMINAL (7)                |
| 3. BULB       | 12. CONNECTOR                   |
| 4. SOCKET     | 13. HAZARD SWITCH ACTUATOR      |
| 5. STRAP      | 14. SPRING CLIP                 |
| 6. ANCHOR (2) | 15. HANDLE                      |
| 7. SCREW (2)  | 16. TURN SIGNAL SWITCH ASSEMBLY |
| 8. CLIP (2)   | 17. WIRE (41C)                  |
| 9. SWITCH     | 18. PIN                         |

TA 237206

## ELECTRICAL SYSTEM.

**3-80. TURN SIGNAL SWITCH REPLACEMENT (Continued).**

LOCATION/ITEM	ACTION	REMARKS
<b><u>D. INSTALLATION.</u></b>		
21 Two screws (7)	Insert two items (7) into two items (6).	
22 Two screws (7) and two anchors (6)	Insert two assembled items (7) and (6) into slots in item (9).	Do not tighten.
23 Strap (5)	Bend through and around one item (8).	
24 Strap (5) and one clip (8)	Put one item (8) between item (6) and item (9).	
25 Switch (9)	Raise into position on steering column and hold.	
26 Strap (5)	Insert unbent portion of item (5) through slot in other item (8). Wrap item (5) around steering column. Estimate length needed to reach item (9) and adjust to suit.	Scrape paint from steering column under item (5) to make ground contact.
27 Clip (8)	Catch item (8) under item (6) and tighten two items (7) equally until item (9) is firmly clamped to steering column.	
28 Connector (12) 29 Wire (17)	Reconnect. Position alongside item (10) and wrap with electrical tape.	

3-464



ELECTRICAL SYSTEM.

3-80. TURN SIGNAL SWITCH REPLACEMENT (Continued).

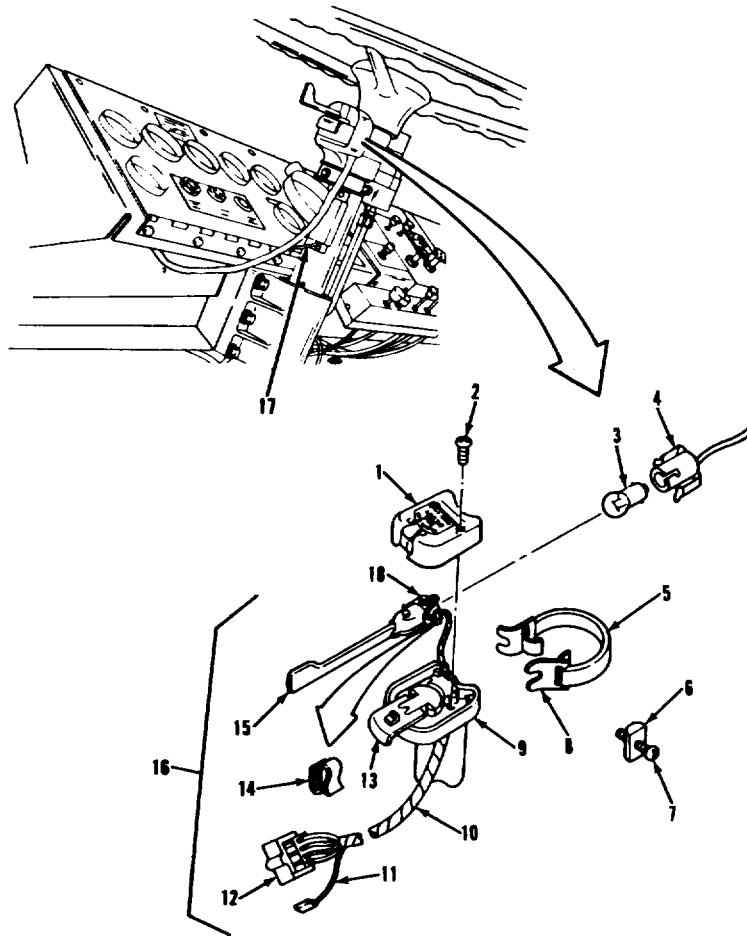

LEGEND:

- |               |                                 |
|---------------|---------------------------------|
| 1. COVER      | 10. HARNESS                     |
| 2. SCREW (2)  | 11. TERMINAL (7)                |
| 3. BULB       | 12. CONNECTOR                   |
| 4. SOCKET     | 13. HAZARD SWITCH ACTUATOR      |
| 5. STRAP      | 14. SPRING CLIP                 |
| 6. ANCHOR (2) | 15. HANDLE                      |
| 7. SCREW (2)  | 16. TURN SIGNAL SWITCH ASSEMBLY |
| 8. CLIP (2)   | 17. WIRE (41C)                  |
| 9. SWITCH     | 18. PIN                         |

TA 237207

**ELECTRICAL SYSTEM.**

**3-80. TURN SIGNAL SWITCH REPLACEMENT (Continued).**

LOCATION/ITEM	ACTION	REMARKS
<b><u>E. OPERATIONAL CHECK.</u></b>		
30. Blackout toggle switch.	Set to normal. 10.	Refer to TM 9-2320-283-10.
31. Handle (15).	a. Place in down position and observe that left green lamp flashes. b. Place in up position and observe that right green lamp flashes.	Refer to TM 9-2320-283-10.
32. Hazard switch actuator (13).	Pull and observe that red lamp flashes.	Refer to TM 9-2320-283-10.
<b>NOTE</b>		
Follow-on maintenance action required:		
None.		
<b>3-466</b>		

ELECTRICAL SYSTEM.

3-80. TURN SIGNAL SWITCH REPLACEMENT (Continued).

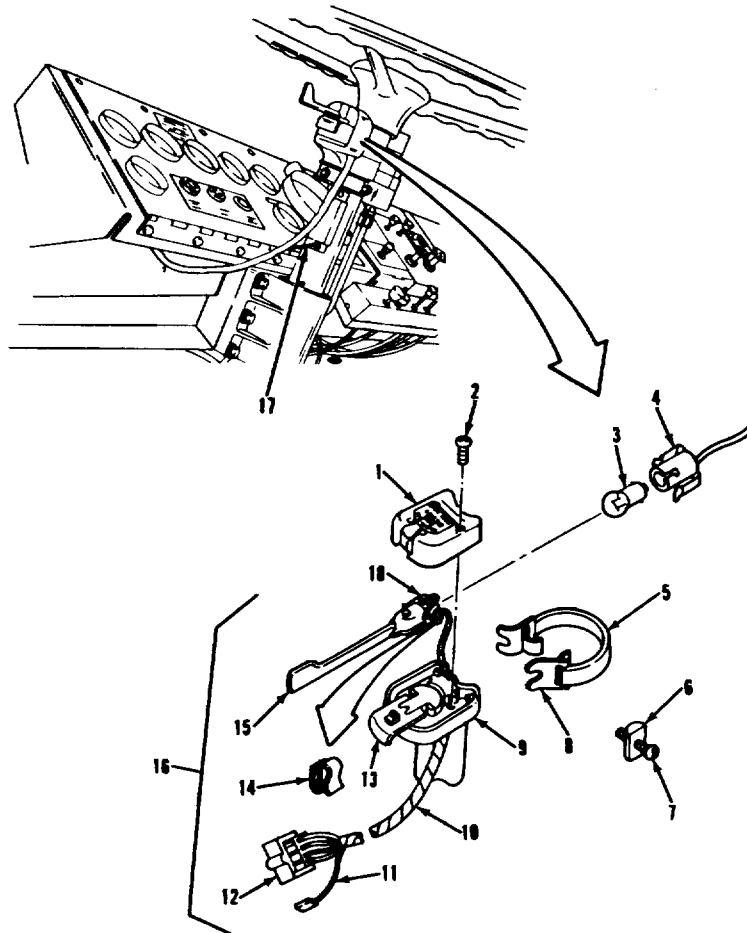

LEGEND:

- |               |                                 |
|---------------|---------------------------------|
| 1. COVER      | 10. HARNESS                     |
| 2. SCREW (2)  | 11. TERMINAL (7)                |
| 3. BULB       | 12. CONNECTOR                   |
| 4. SOCKET     | 13. HAZARD SWITCH ACTUATOR      |
| 5. STRAP      | 14. SPRING CLIP                 |
| 6. ANCHOR (2) | 15. HANDLE                      |
| 7. SCREW (2)  | 16. TURN SIGNAL SWITCH ASSEMBLY |
| 8. CLIP (2)   | 17. WIRE (41C)                  |
| 9. SWITCH     | 18. PIN                         |

TA 237208

**ELECTRICAL SYSTEM.**  
**3-81. HEATER FAN SWITCH REPLACEMENT.**

---

THIS TASK COVERS

- a. Removal.
- b. Installation.
- c. Operational Check.

---

INITIAL SETUP

APPLICABLE CONFIGURATIONS  
 All.

EQUIPMENT CONDITION  
 PARAGRAPH  
 3-120.

CONDITION DESCRIPTION  
 Battery power  
 disconnected.

TEST EQUIPMENT

None.

SPECIAL TOOLS

None.

MATERIALS/PARTS (P/N)

None.

PERSONNEL REQUIRED

One (MOS-63S).

REFERENCES (TM)

TM 9-2320-283-10.

Transmission in neutral.

Park brake set.

TROUBLESHOOTING REFERENCES

Paragraph 2-11.

SPECIAL ENVIRONMENTAL CONDITIONS

Vehicle parked on level ground.

GENERAL SAFETY INSTRUCTIONS

Engine off.

ELECTRICAL SYSTEM.

1 3-81. HEATER FAN SWITCH REPLACEMENT (Continued).

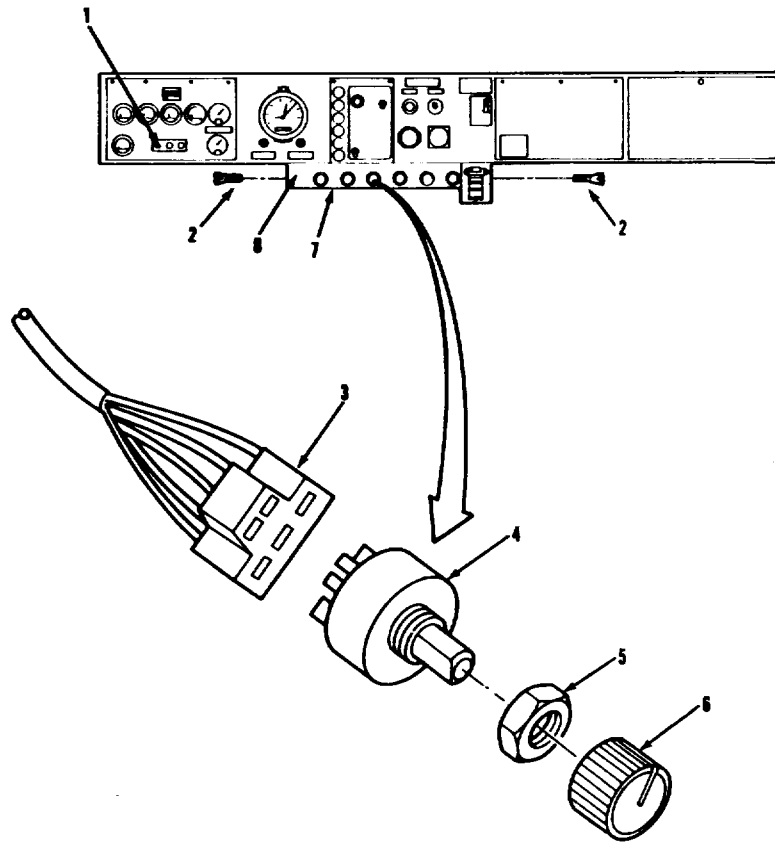

LEGEND:

- 1. ENGINE RUN SWITCH
- 2. SCREW (2)
- 3. CONNECTOR
- 4. HEATER FAN SWITCH

- 5. HEX NUT
- 6. HEATER KNOB
- 7. BACK PANEL COVER
- 8. LOWER CONTROL PANEL

TA 237209

**ELECTRICAL SYSTEM.**

**3-81. HEATER FAN SWITCH REPLACEMENT (Continued).**

LOCATION/ITEM	ACTION	REMARKS
<b>A. REMOVAL. I</b>		
1. Two screws (2).	Remove.	
2. Back panel cover (7).	Slide back over cables.	
3. Heater knob (6).	Pull off.	
4. Hex nut (5).	Remove.	
5. Heater fan switch (4).	Remove from item (8).	
6. Connector (3).	Remove from item (4).	
<b>B. INSTALLATION.</b>		
7. Connector (3).	Install on item (4).	
8. Heater fan switch (4).	Aline and install in item (8).	
9. Hex nut (5).	Install and tighten.	
10. Heater knob (6).	Install.	
11. Back panel cover (7).	Slide over cables and press on back of item (8).	
12. Two screws (2).	Install and tighten.	
13. Batteries.	Connect.	Refer to paragraph 3-120.
<b>3-470</b>		

ELECTRICAL SYSTEM.

3-81. HEATER FAN SWITCH REPLACEMENT (Continued).

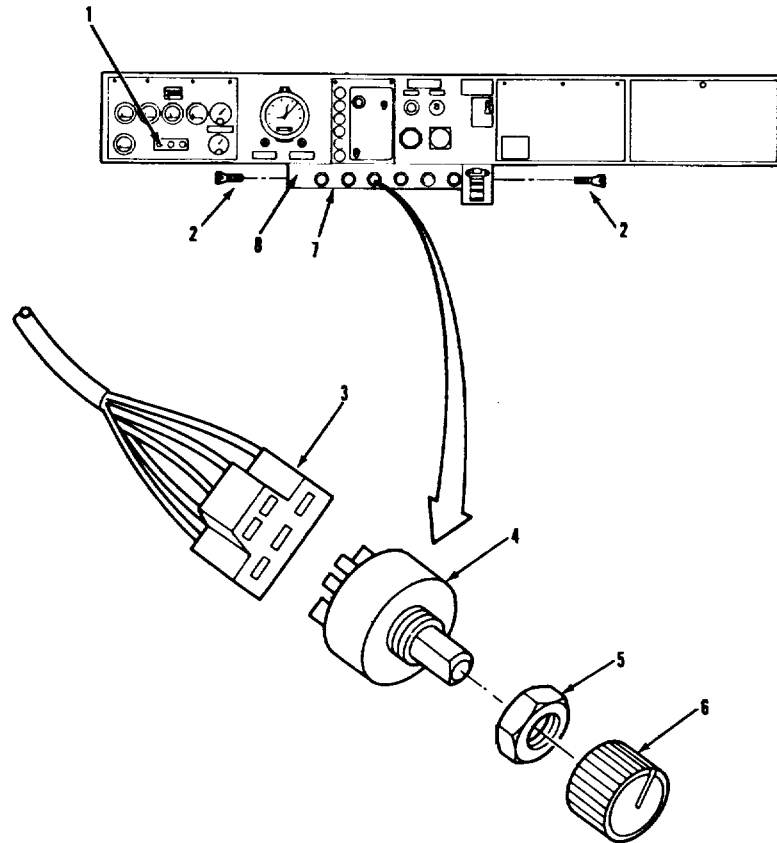

LEGEND:

- 1. ENGINE RUN SWITCH
- 2. SCREW (2)
- 3. CONNECTOR
- 4. HEATER FAN SWITCH

- 5. HEX NUT
- 6. HEATER KNOB
- 7. BACK PANEL COVER
- 8. LOWER CONTROL PANEL

TA 237210

**ELECTRICAL SYSTEM.**

**3-81. HEATER FAN SWITCH REPLACEMENT (Continued).**

LOCATION/ITEM	ACTION	REMARKS
<b><u>C. OPERATIONAL CHECK.</u></b>		
14. Engine run switch (1)	Turn left to accessory	Refer to TM 9-2320-283-10.
15. Heater fan switch (4)	Rotate item (6) through all positions (LO, MED, HI) and verify the heater fan increases and decreases accordingly. Verify that fan motor shuts off with item (6) set to OFF.	
Follow-on maintenance action required: None.		<b>NOTE</b>
		<b>3-472</b>



ELECTRICAL SYSTEM.

3-81. HEATER FAN SWITCH REPLACEMENT (Continued).

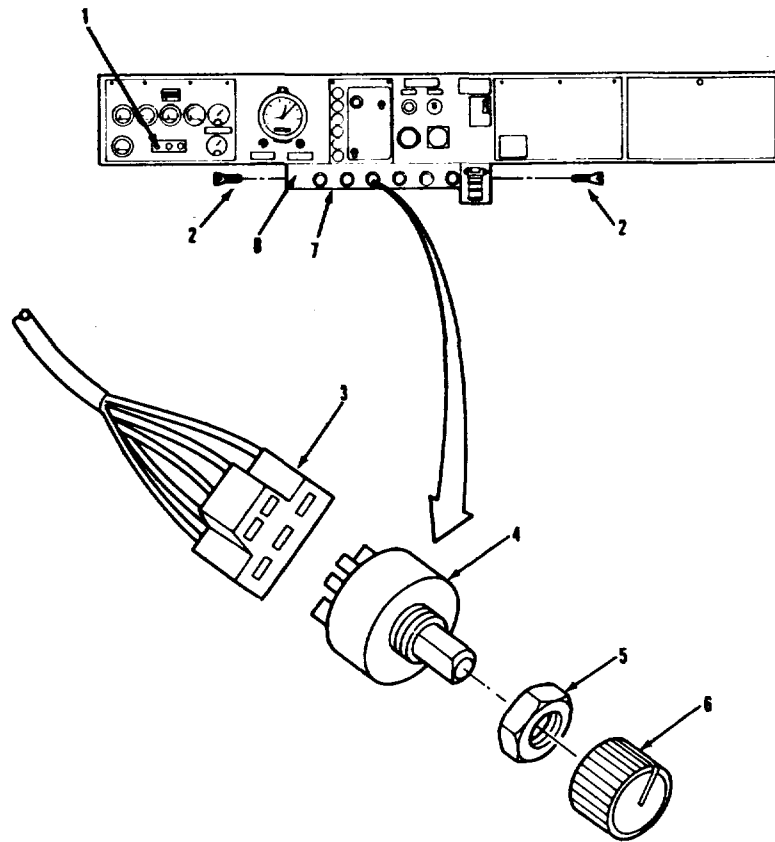

LEGEND:

- 1. ENGINE RUN SWITCH
- 2. SCREW (2)
- 3. CONNECTOR
- 4. HEATER FAN SWITCH

- 5. HEX NUT
- 6. HEATER KNOB
- 7. BACK PANEL COVER
- 8. LOWER CONTROL PANEL

TA 237211

**ELECTRICAL SYSTEM.****3-82. HEADLAMP DIMMER SWITCH REPLACEMENT.**

---

THIS TASK COVERS

- a. Removal.
- b. Installation.
- c. Operational Check.

---

INITIAL SETUPAPPLICABLE CONFIGURATIONS

All.

TEST EQUIPMENT

None.

SPECIAL TOOLS

None.

MATERIALS/PARTS (P/N)

None.

PERSONNEL REQUIRED

One (MOS-63S).

REFERENCES (TM)

TM 9-2320-283-10.

TM 9-2320-283-20P.

TROUBLESHOOTING REFERENCES

Paragraph 2-11.

EQUIPMENT CONDITIONPARAGRAPH

TM 9-2320-283-10.

CONDITION DESCRIPTION

Headlamp switch off.

SPECIAL ENVIRONMENTAL CONDITIONS

Vehicle parked on level ground.

GENERAL SAFETY INSTRUCTIONS

Engine off.

Transmission in neutral.

Park brake set.

ELECTRICAL SYSTEM.

3-82. HEADLAMP DIMMER SWITCH REPLACEMENT (Continued).

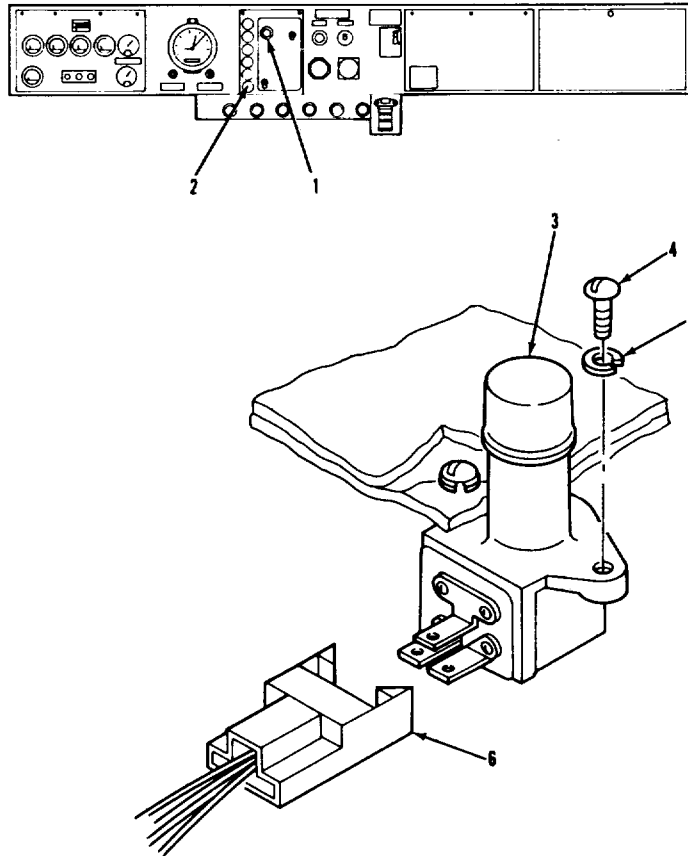

LEGEND:

- 1. LAMP SWITCH
- 2. HIGH BEAM INDICATOR LAMP
- 3. HEADLAMP DIMMER SWITCH

- 4. SCREW (2)
- 5. LOCKWASHER (2)
- 6. CONNECTOR

TA 237212

**ELECTRICAL SYSTEM.**

**3-82. HEADLAMP DIMMER SWITCH REPLACEMENT (Continued).**

LOCATION/ITEM	ACTION	REMARKS
<b><u>A. REMOVAL.</u></b>		
1. Floor mat.	Lift from item (3).	
2. Two screws (4) and lockwashers (5).	Remove.	
3. Switch (3).	Remove from under cab floor-board.	
4. Connector (6).	Remove.	
<b><u>B. INSTALLATION.</u></b>		
5. Connector (6).	Install on item (3).	
6. Switch (3).	Install into cab floorboard.	Install from under cab.
7. Two lockwashers (5) and screws (4).	Install and tighten.	
8. Floor mat.	Replace.	
<b><u>C. OPERATIONAL CHECK.</u></b>		
9. Lamp switch (1).	Pull on.	Refer to TM 9-2320-283-10.
10. Switch (3). item (2) comes on.	a. Press down. Verify that 10. b. Press down again and verify that item (2) goes out. c. Push headlamp switch (1) to off.	Refer to TM 9-2320-283-
<b>NOTE</b>		
Follow-on maintenance action required:		
None.		
<b>3-476</b>		

ELECTRICAL SYSTEM.

3-82. HEADLAMP DIMMER SWITCH REPLACEMENT (Continued).

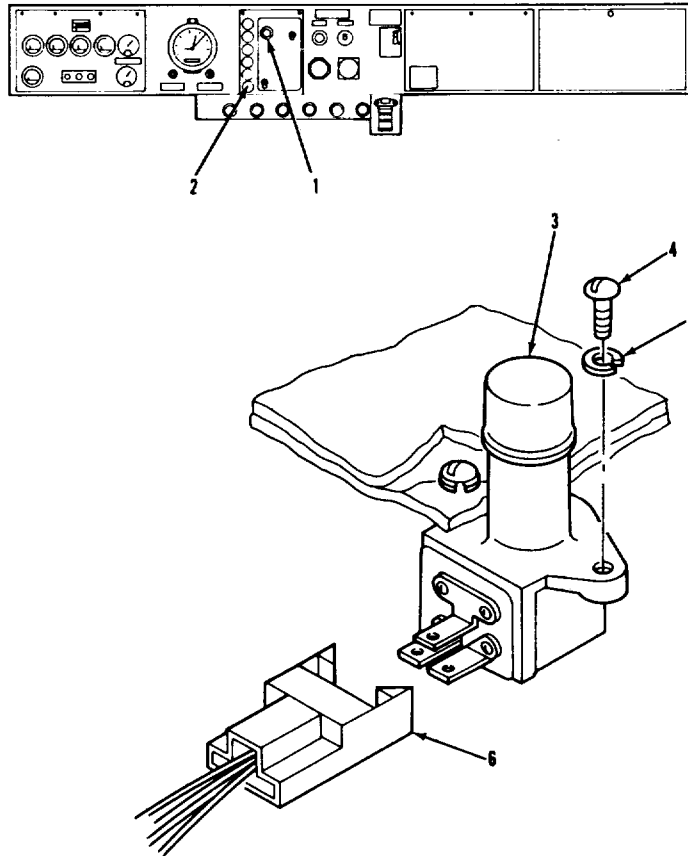

LEGEND:

- 1. LAMP SWITCH
- 2. HIGH BEAM INDICATOR LAMP
- 3. HEADLAMP DIMMER SWITCH

- 4. SCREW (2)
- 5. LOCKWASHER (2)
- 6. CONNECTOR

TA 237212

**ELECTRICAL SYSTEM.**

**3-83. CIGAR LIGHTER REPLACEMENT.**

---

THIS TASK COVERS

- a. Removal.
  - b. Installation.
  - c. Operational Check.
- 

INITIAL SETUP

APPLICABLE CONFIGURATIONS

All.

EQUIPMENT CONDITION

PARAGRAPH

3-120.

CONDITION DESCRIPTION

Battery power disconnected.

TEST EQUIPMENT

None.

SPECIAL TOOLS

None.

MATERIALS/PARTS (P/N)

None.

PERSONNEL REQUIRED

One (MOS-63S).

REFERENCES (TM)

TM 9-2320-283-10.

SPECIAL ENVIRONMENTAL CONDITIONS

Vehicle parked on level ground.

GENERAL SAFETY INSTRUCTIONS

Engine off.

Park brake set.

Transmission in neutral.

TROUBLESHOOTING REFERENCES

Paragraph 2-11.

ELECTRICAL SYSTEM.

3-83. CIGAR LIGHTER REPLACEMENT (Continued).

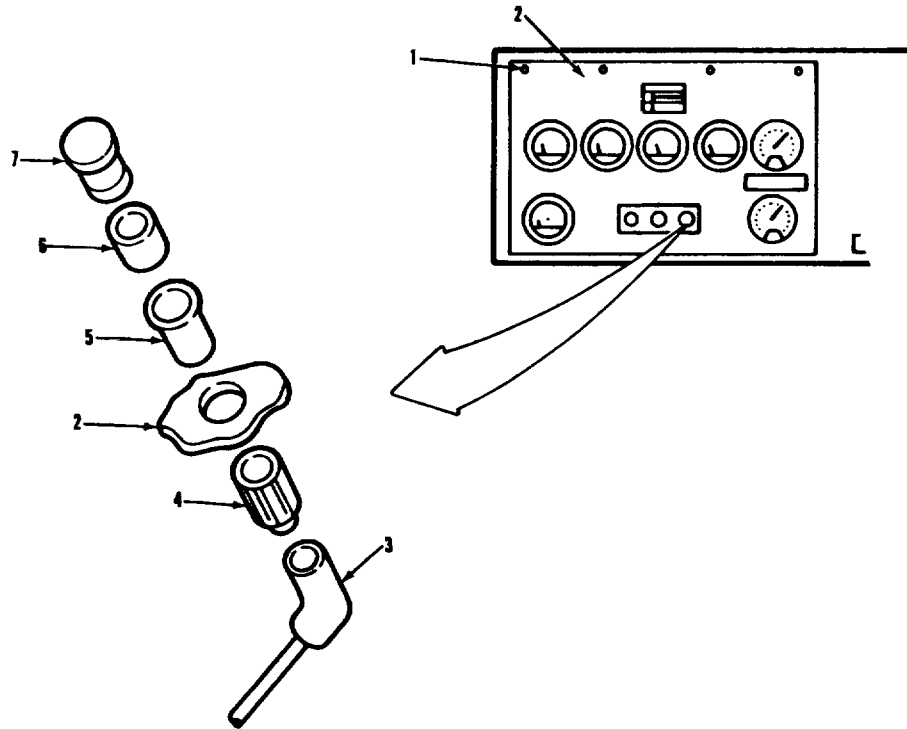

LEGEND:

- 1. QUARTER-TURN SCREW (4)
- 2. INSTRUMENT PANEL
- 3. WIRE CAP CONNECTOR
- 4. SHELL

- 5. DIAPHRAGM
- 6. HEATING UNIT
- 7. KNOB

TA 237214

**ELECTRICAL SYSTEM.**

**3-83. CIGAR LIGHTER REPLACEMENT (Continued).**

LOCATION/ITEM	ACTION	REMARKS
1. Four screws (1). 2. Instrument panel (2). 3. Connector (3). 4. Heating unit (6) and knob (7). 5. Shell (4). 6. Diaphragm (5).	Loosen. Lower. Remove. Remove item (6) from item (7). Unscrew from item (5). Remove from item (2).	Clean.
<b>B. INSTALLATION.</b>		
7. Diaphragm (5).	Install in item (2) from front.	
8. Shell (4).	Install on item (5) and tighten.	Be sure item (4) makes good ground contact with item (2).
9. Connector (3). 10. Knob (7) and heating unit (6).	Install on item (5). Connect together.	
11. Instrument panel (2). 12. Four screws (1). 13. Batteries.	Raise into place. Tighten. Connect.	Refer to paragraph 3-120.
<b>C. OPERATIONAL CHECK.</b>		
14. Knob (7) and heating unit (6).	Insert and press. Verify that element gets hot.	
<b>NOTE</b>		
Follow-on maintenance action required: None.		
<b>3-480</b>		



ELECTRICAL SYSTEM.

3-83. CIGAR LIGHTER REPLACEMENT (Continued).

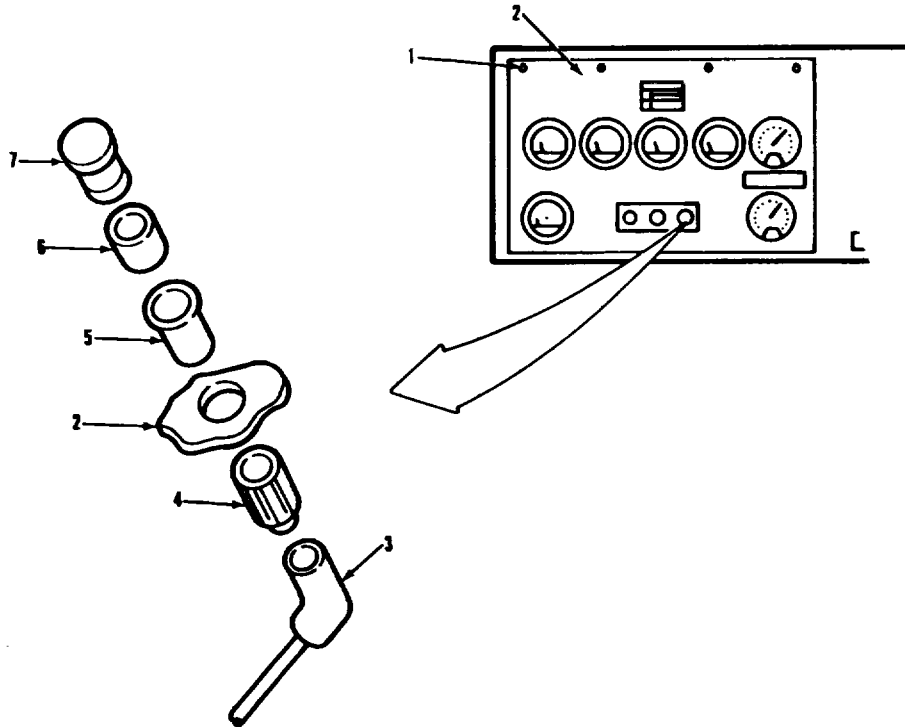

LEGEND:

- 1. QUARTER-TURN SCREW (4)
- 2. INSTRUMENT PANEL
- 3. WIRE CAP CONNECTOR
- 4. SHELL

- 5. DIAPHRAGM
- 6. HEATING UNIT
- 7. KNOB

TA 237215

**ELECTRICAL SYSTEM.**

**3-84. LOW AIR PRESSURE LAMP REPLACEMENT.**

---

THIS TASK COVERS

- a. Removal.
  - b. Installation
  - c. Operational Check.
- 

INITIAL SETUP

APPLICABLE CONFIGURATIONS

EQUIPMENT CONDITION  
PARAGRAPH  
All.

CONDITION DESCRIPTION  
3-120. Battery power  
disconnected.

TEST EQUIPMENT

None.

SPECIAL TOOLS

None.

MATERIALS/PARTS (P/N)

None.

PERSONNEL REQUIRED

One (MOS-63S ).

REFERENCES (TM)

TM 9-2320-283-10.

SPECIAL ENVIRONMENTAL CONDITIONS

None.

GENERAL SAFETY INSTRUCTIONS

Engine off.  
Park brake set.  
Transmission in neutral.

TROUBLESHOOTING REFERENCES

Paragraph 2-11.

ELECTRICAL SYSTEM.

3-84. LOW AIR PRESSURE LAMP REPLACEMENT (Continued).

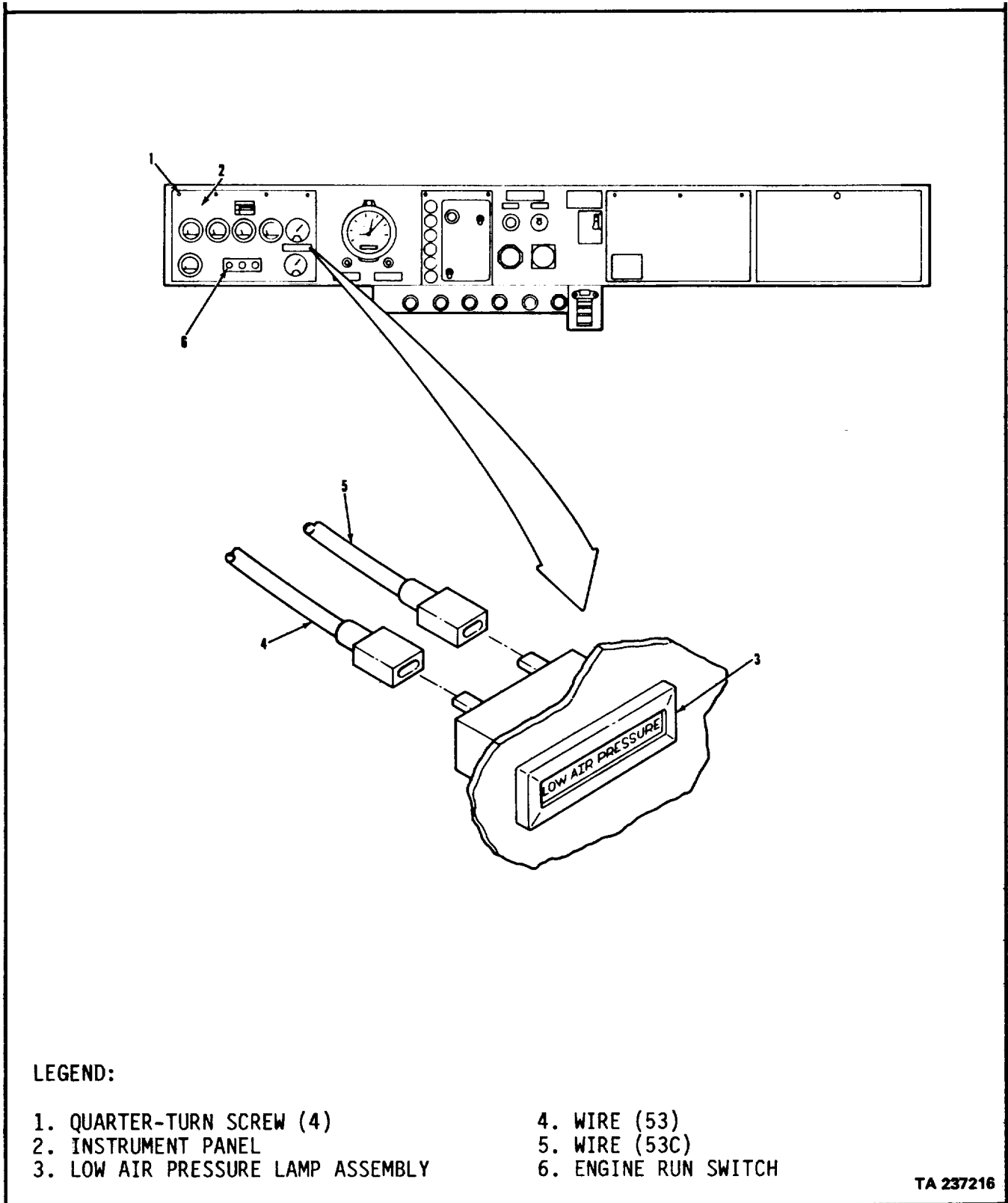

TA 237216

**ELECTRICAL SYSTEM.**

**3-84. LOW AIR PRESSURE LAMP REPLACEMENT (Continued).**

LOCATION/ITEM	ACTION	REMARKS
<b><u>A. REMOVAL.</u></b>		
1. Four screws (1)	Loosen.	
2. Instrument panel (2).	Lower.	
3. Wires (4) and (5)	Remove	Tag for identification.
4. Low air pressure lamp assembly (3).	Remove.	
<b><u>B. INSTALLATION.</u></b>		
5. Low air pressure lamp assembly (3)	Aline and press into item (2).	
6. Wires (4) and (5)	Connect	Connect according to identification tag from step 3.
7. Instrument panel (2).	Raise into place.	
8. Four screws (1)	Tighten.	
9. Batteries	Connect	Refer to paragraph 3-120.
<b><u>C. OPERATIONAL CHECK.</u></b>		
10. Air pressure supply reservoir	Bleed off air pressure	Refer to TM 9-2320-283-10.
11. Engine run switch	a. Turn on. b. Verify that item (3) comes on.	
<b>NOTE</b>		
Follow-on maintenance action required:		
None.		
<b>3-484</b>		

ELECTRICAL SYSTEM.

3-84. LOW AIR PRESSURE LAMP REPLACEMENT (Continued).

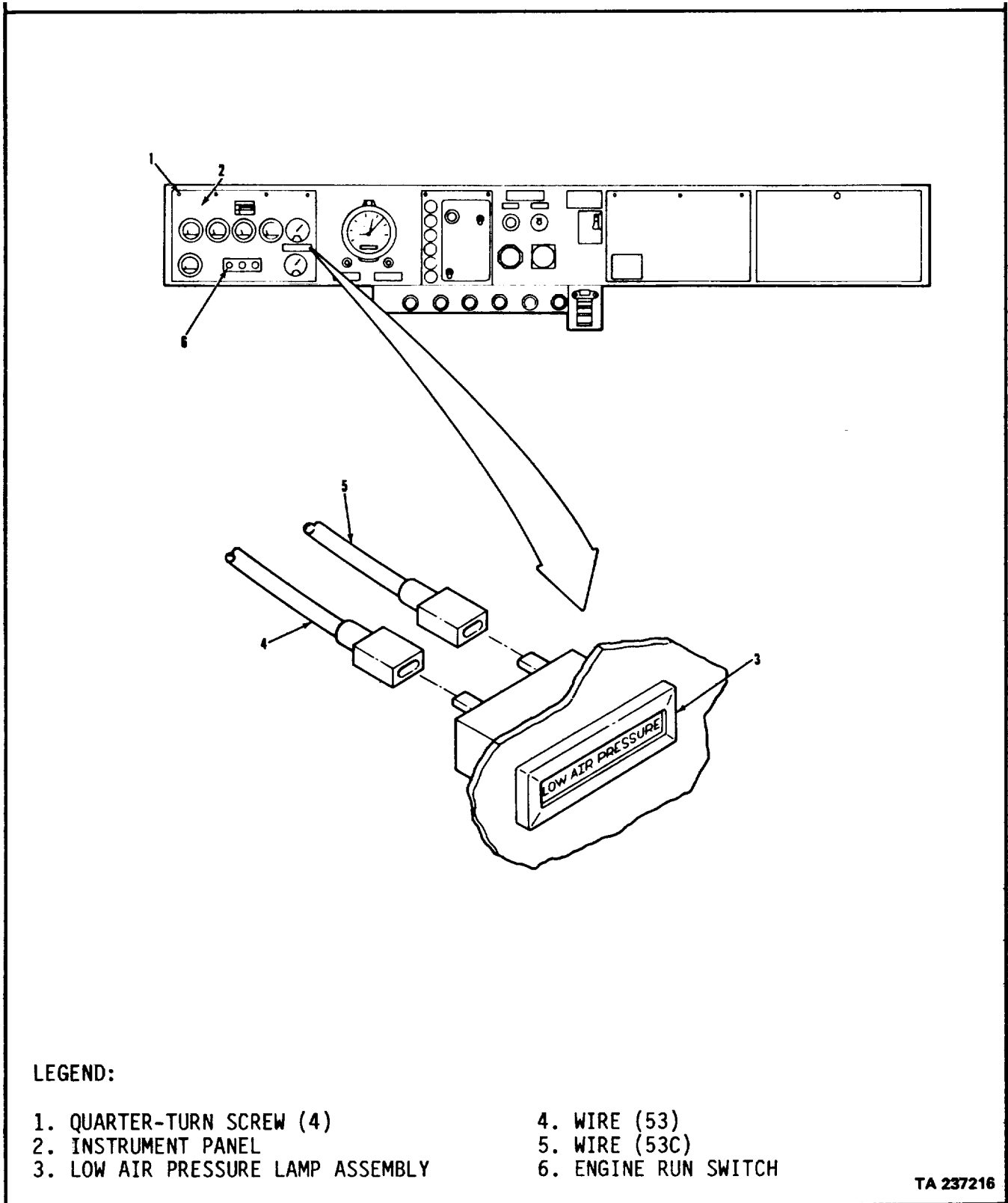

TA 237216

**ELECTRICAL SYSTEM.**

**3-85. ETHER LAMP AND CLEARANCE LAMP REPLACEMENT.**

---

THIS TASK COVERS

- a. Removal.
- b. Installation.
- c. Operational Check.

INITIAL SETUP

<u>APPLICABLE CONFIGURATIONS</u>	<u>EQUIPMENT CONDITION PARAGRAPH</u>	<u>CONDITION DESCRIPTION</u>
All. disconnected.	3-120.	Battery power
<u>TEST EQUIPMENT</u>		
None.		
<u>SPECIAL TOOLS</u>		
None.		
<u>MATERIALS/PARTS (P/N)</u>		
Seal, O-ring (15434) 3030808.		
<u>PERSONNEL REQUIRED</u>	<u>SPECIAL ENVIRONMENTAL CONDITIONS</u>	
One (MOS-63S).	None.	
<u>REFERENCES (TM)</u>	<u>GENERAL SAFETY INSTRUCTIONS</u>	
TM 9-2320-283-10. Transmission in neutral. Park brake set.	Engine off.	
<u>TROUBLESHOOTING REFERENCES</u>		
Paragraph 2-11.		

ELECTRICAL SYSTEM.

3-85. ETHER LAMP AND CLEARANCE LAMP REPLACEMENT (Continued).

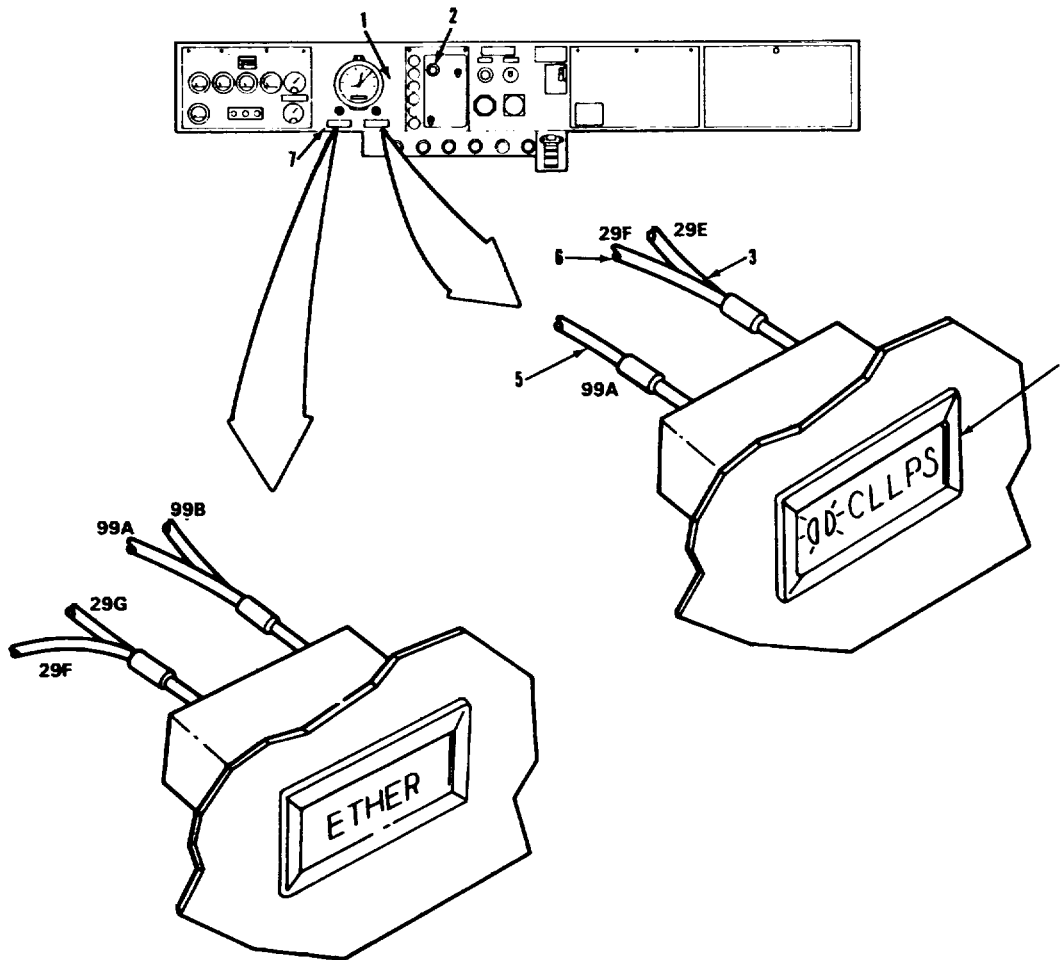

LEGEND:

- |                     |               |
|---------------------|---------------|
| 1. INSTRUMENT PANEL | 5. WIRE (99A) |
| 2. HEADLAMP SWITCH  | 6. WIRE (29F) |
| 3. WIRE (29E)       | 7. ETHER LAMP |
| 4. CLEARANCE LAMP   |               |

TA 237218

**ELECTRICAL SYSTEM.**

**3-85. ETHER LAMP AND CLEARANCE LAMP REPLACEMENT (Continued).**

LOCATION/ITEM	ACTION	REMARKS
<p><b>NOTE</b>                      Clearance lamp replacement and ether lamp replacement are the similar. This procedure covers clearance lamp re- placement.</p>		
<p><b><u>A. REMOVAL.</u></b></p>		
<p>1. Wire (5), wire (6), and wire (3).</p>	<p>Remove from underneath item (1). Item (6) and item (3)</p>	<p>Tag for identification. share a common terminal.</p>
<p>2. Clearance lamp (4).</p>	<p>Remove from item (1) by pushing outward from behind.</p>	
<p><b><u>B. INSTALLATION.</u></b></p>		
<p>3. Clearance lamp (4).</p>	<p>Aline and press into item (1).</p>	
<p>4. Wire (5), wire (6), and wire (3).</p>	<p>Connect.</p>	<p>Connect according to identification tag from step 1.</p>
<p>5. Batteries.</p>	<p>Connect.</p>	<p>Refer to paragraph 3-120.</p>
<p><b><u>C. OPERATIONAL CHECK.</u></b></p>		
<p>6. Headlamp switch (2).</p>	<p>a. Pull out to first stop. 283-10. b. Verify that item (4) comes on.</p>	<p>Refer to TM 9-2320-</p>
<p><b>NOTE</b> Follow-on maintenance action required: None.</p>		
<p><b>3-488</b></p>		



ELECTRICAL SYSTEM.

3-85. ETHER LAMP AND CLEARANCE LAMP REPLACEMENT (Continued).

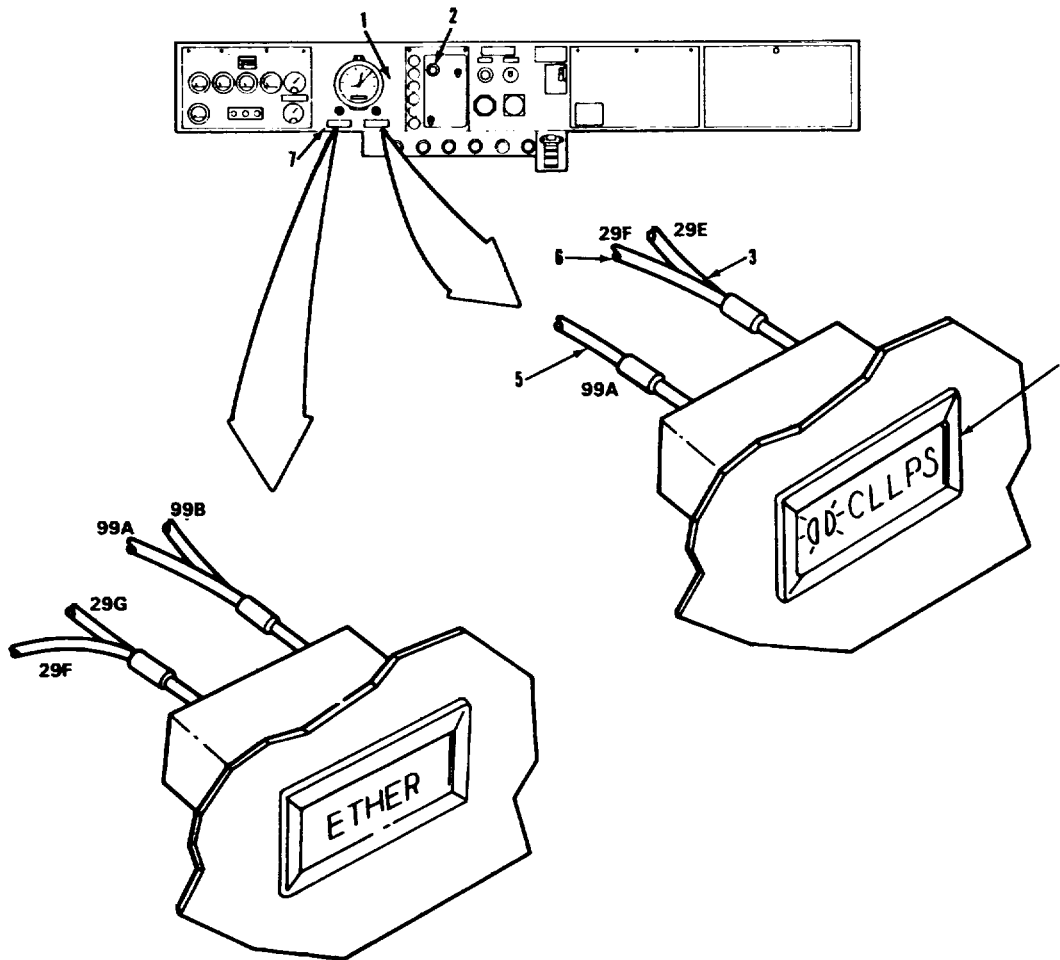

LEGEND:

- |                     |               |
|---------------------|---------------|
| 1. INSTRUMENT PANEL | 5. WIRE (99A) |
| 2. HEADLAMP SWITCH  | 6. WIRE (29F) |
| 3. WIRE (29E)       | 7. ETHER LAMP |
| 4. CLEARANCE LAMP   |               |

TA 237218

**ELECTRICAL SYSTEM.**

**3-86. WIPER LAMP AND WASHER LAMP REPLACEMENT.**

---

THIS TASK COVERS

- a. Removal.
  - b. Installation.
  - c. Operational Check.
- 

INITIAL SETUP

APPLICABLE CONFIGURATIONS

All.

EQUIPMENT CONDITION

PARAGRAPH

3-120.

CONDITION DESCRIPTION

Battery power disconnected.

TEST EQUIPMENT

None.

SPECIAL TOOLS

None.

MATERIALS/PARTS (P/N)

None.

PERSONNEL REQUIRED

One (MOS-63S).

SPECIAL ENVIRONMENTAL CONDITIONS

None.

REFERENCES (TM)

TM 9-2326-283-10.

GENERAL SAFETY INSTRUCTIONS

Engine off.

Transmission in neutral.

Park brake set.

TROUBLESHOOTING REFERENCES

Paragraph 2-11.

Wait until exhaust components are cool.

ELECTRICAL SYSTEM.

3-86. WIPER LAMP AND WASHER LAMP REPLACEMENT (Continued).

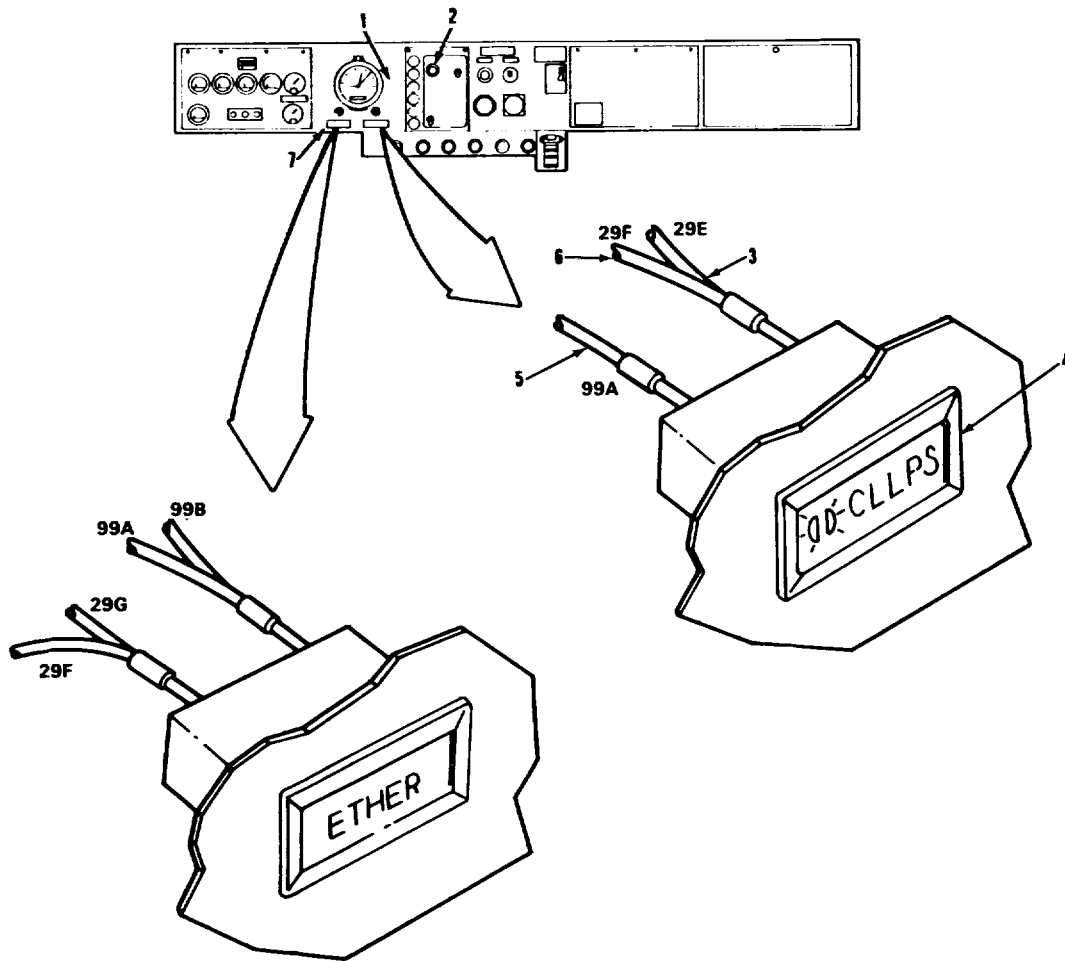

LEGEND:

- |                     |               |
|---------------------|---------------|
| 1. INSTRUMENT PANEL | 5. WIRE (99A) |
| 2. HEADLAMP SWITCH  | 6. WIRE (29F) |
| 3. WIRE (29E)       | 7. ETHER LAMP |
| 4. CLEARANCE LAMP   |               |

TA 237219

**ELECTRICAL SYSTEM.**

**3-86. WIPER LAMP AND WASHER LAMP REPLACEMENT (Continued).**

LOCATION/ITEM	ACTION	REMARKS
<p><b>NOTE</b> Wiper lamp replacement and washer lamp replacement are similar. This procedure covers wiper lamp replacement.</p>		
<p><b><u>A. REMOVAL.</u></b></p>		
1. Two quarter-turn screws (1).	Loosen.	
2. Instrument panel (3).	Lower.	
3. Wire (6), wire (7), and wire (8).	Remove.	Tag for identification.
4. Wiper lamp (5).	Wire (6) and wire (7) share a common terminal. Remove from item (3) by pushing outward from behind.	
<p><b><u>B. INSTALLATION.</u></b></p>		
5. Wiper lamp (5).	Align and press into item (3).	
6. Wire (6), wire (7), and wire (8).	Connect.	Connect according to identification tag from step 3.
7. Instrument panel (3).	Raise.	
8. Two quarter-turn screws (1).	Tighten.	
<p><b>3-492</b></p>		

ELECTRICAL SYSTEM.

3-86. WIPER LAMP AND WASHER LAMP REPLACEMENT (Continued).

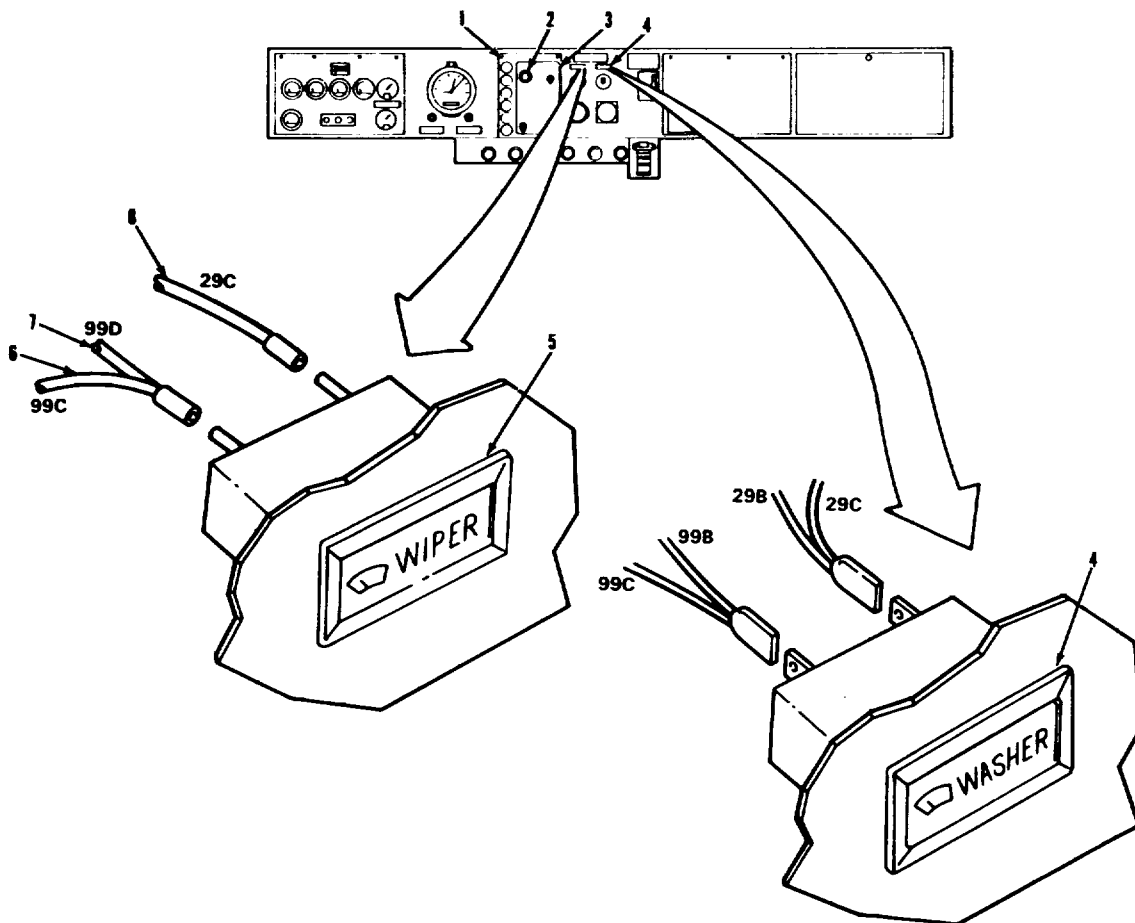

LEGEND:

- |                           |               |
|---------------------------|---------------|
| 1. QUARTER-TURN SCREW (2) | 5. WIPER LAMP |
| 2. HEADLAMP SWITCH        | 6. WIRE (99C) |
| 3. INSTRUMENT PANEL       | 7. WIRE(99D)  |
| 4. WASHER LAMP            | 8. WIRE(99C)  |

**ELECTRICAL SYSTEM.**

<b>3-86. WIPER LAMP AND WASHER LAMP REPLACEMENT (Continued).</b>		
<b>LOCATION/ITEM</b>	<b>ACTION</b>	<b>REMARKS</b>
<b><u>B. INSTALLATION (Continued).</u></b>		
9. Batteries	Connect	Refer to paragraph 3-120.
<b><u>C. OPERATIONAL CHECK.</u></b>		
10. Headlamp switch (2).	a. Pull out to first stop. b. Verify that item (5) comes on	Refer to TM 9-2320-283-10.
<p>NOTE Follow-on maintenance action required:  None.</p>		

ELECTRICAL SYSTEM.

3-86. WIPER LAMP AND WASHER LAMP REPLACEMENT (Continued).

LOCATION/ITEM	ACTION	REMARKS
---------------	--------	---------

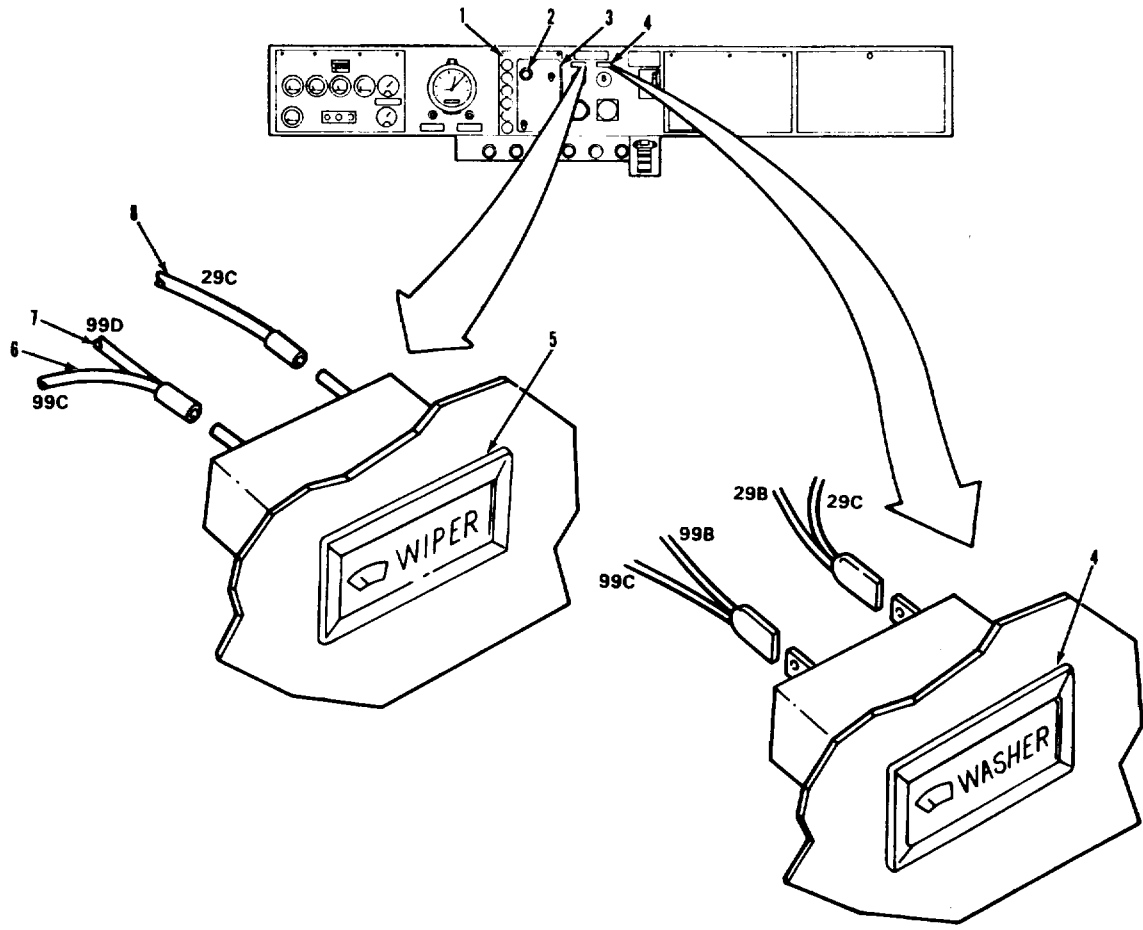

LEGEND:

- |                           |               |
|---------------------------|---------------|
| 1. QUARTER-TURN SCREW (2) | 5. WIPER LAMP |
| 2. HEADLAMP SWITCH        | 6. WIRE (99C) |
| 3. INSTRUMENT PANEL       | 7. WIRE (99D) |
| 4. WASHER LAMP            | 8. WIRE (99C) |

**ELECTRICAL SYSTEM.**

<b>3-87. WARNING AND INDICATOR LAMPS REPLACEMENT</b>		
<u>THIS TASK COVERS</u>		
<ul style="list-style-type: none"> <li>a. Marker Lamp Removal</li> <li>b. Marker Lamp Installation</li> <li>c. Tube Assembly and Lenses Removal</li> </ul>	<ul style="list-style-type: none"> <li>d. Tube Assembly and Lenses Installation.</li> <li>e. Operational Check.</li> </ul>	
<u>INITIAL SETUP</u>		
<u>APPLICABLE CONFIGURATIONS</u>	<u>EQUIPMENT CONDITION PARAGRAPH</u>	<u>CONDITION DESCRIPTION</u>
All	None	None.
<u>TEST EQUIPMENT</u>		
None.		
<u>SPECIAL TOOLS</u>		
None.		
<u>MATERIALS/PARTS (P/N</u>		
Rivet, blind, 3/16" 2) (05693) SSP-62.		
<u>PERSONNEL REQUIRED</u>	<u>SPECIAL ENVIRONMENTAL CONDITIONS</u>	
One (MOS-63S )	None.	
<u>REFERENCES (TM)</u>	<u>GENERAL SAFETY INSTRUCTIONS</u>	
TM 9-2320-283-10 TM 9-2320-283-20P	Engine off. Transmission in neutral. Park brake set.	
<u>TROUBLESHOOTING REFERENCES</u>		
Paragraph 2-11.		



ELECTRICAL SYSTEM.

3-87. WARNING AND INDICATOR LAMPS REPLACEMENT (Continued).

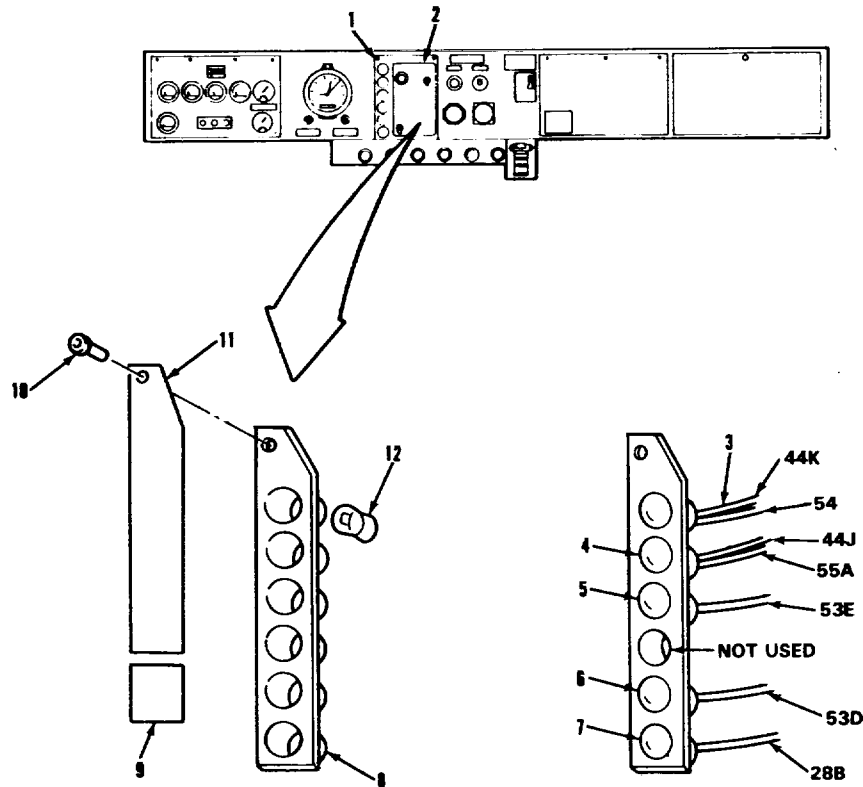

LEGEND:

- |  |  |
|--|--|
| 1. QUARTER-TURN SCREW (2)                        | 6. PARK BRAKE SOCKET AND WIRE ASSEMBLY |
| 2. INSTRUMENT PANEL                              | 7. HIGH BEAM SOCKET AND WIRE ASSEMBLY  |
| 3. ENGINE OIL SOCKET AND WIRE ASSEMBLY           | 8. TUBE ASSEMBLY                       |
| 4. ENGINE TEMPERATURE SOCKET AND WIRE ASSEMBLY   | 9. LENS                                |
| 5. DIFFERENTIAL LOCKOUT SOCKET AND WIRE ASSEMBLY | 10. RIVET (2)                          |
|  | 11. LENS                               |
|  | 12. MARKER LAMP (5)                    |

**ELECTRICAL SYSTEM.**

<b>3-87. WARNING AND INDICATOR LAMPS REPLACEMENT (Continued).</b>		
<b>LOCATION/ITEM</b>	<b>ACTION</b>	<b>REMARKS</b>
<p><b>NOTE</b></p> <p>The steps required to replace any of the warning and indicator lamps are the same This procedure covers replacement of the engine oil warning lamp.</p>		
<b><u>A. MARKER LAMP REMOVAL.</u></b>		
1. Two quarter-turn screws (1).	Loosen.	
2. Instrument panel (2).	Lower.	
3. Engine oil socket and wire assembly (3).	Remove from item (8)	Pull straight out.
4. Marker lamp (12)	Remove from item (3)	Tag for identification.
<b><u>B. MARKER LAMP INSIALATION.</u></b>		
5. Marker lamp (12)	Install in item (3).	
6. Engine oil socket and wire assembly (3)	Insert in item (8)	Install according to identification tag from step 3.

ELECTRICAL SYSTEM.

3-87. WARNING AND INDICATOR LAMPS REPLACEMENT (Continued).

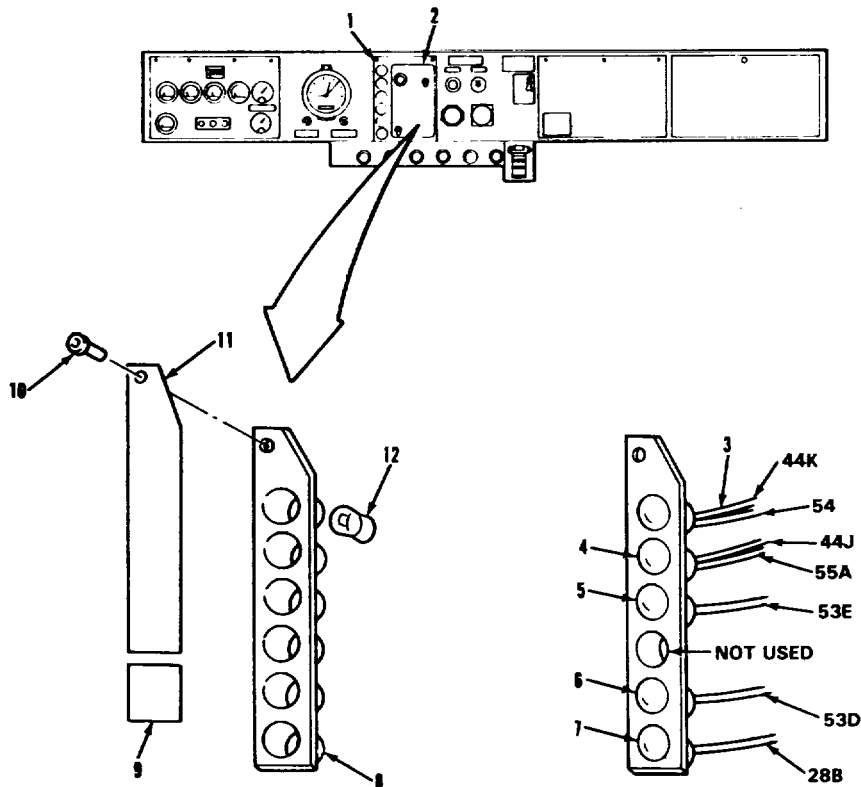

LEGEND:

- |  |  |
|--|--|
| 1. QUARTER-TURN SCREW (2)                        | 6. PARK BRAKE SOCKET AND WIRE ASSEMBLY |
| 2. INSTRUMENT PANEL                              | 7. HIGH BEAM SOCKET AND WIRE ASSEMBLY  |
| 3. ENGINE OIL SOCKET AND WIRE ASSEMBLY           | 8. TUBE ASSEMBLY                       |
| 4. ENGINE TEMPERATURE SOCKET AND WIRE ASSEMBLY   | 9. LENS                                |
| 5. DIFFERENTIAL LOCKOUT SOCKET AND WIRE ASSEMBLY | 10. RIVET (2)                          |
|  | 11. LENS                               |
|  | 12. MARKER LAMP (5)                    |

## ELECTRICAL SYSTEM.

<b>3-87. WARNING AND INDICATOR LAMPS REPLACEMENT (Continued).</b>		
<b>LOCATION/ITEM</b>	<b>ACTION</b>	<b>REMARKS</b>
<b><u>C. TUBE ASSEMBLY AND LENSES REMOVAL.</u></b>		
7. Engine oil socket and wire assembly (3), engine temperature socket and wire assembly (4), differential lockout socket and wire assembly (5), park brake socket and wire assembly (6), and high beam socket and wire assembly (7).	Remove from item (8) for identification.	Pull straight out. Tag
8. Instrument panel (2).	Raise	Do not tighten.
9. Two rivets (10)	Drill out, remove, and discard.	Use 3/16" drill bit.
10. Instrument panel (2).	Lower.	
11. Tube assembly (8)	Remove.	
12. Lens (9) and lens (10).	Remove.	
<b><u>D. TUBE ASSEMBLY AND LENSES INSTALLATION.</u></b>		
13. Lens (9) and lens (11)	Install on item (8)	Match notch in top corner of item (11) with notch in top corner of item (8).
14. Tube assembly (8), lens (9), and lens (11)	Aline with mounting holes in item (2). Secure with two new items (10).	

ELECTRICAL SYSTEM.

3-87. WARNING AND INDICATOR LAMPS REPLACEMENT (Continued).

LOCATION/ITEM	ACTION	REMARKS
---------------	--------	---------

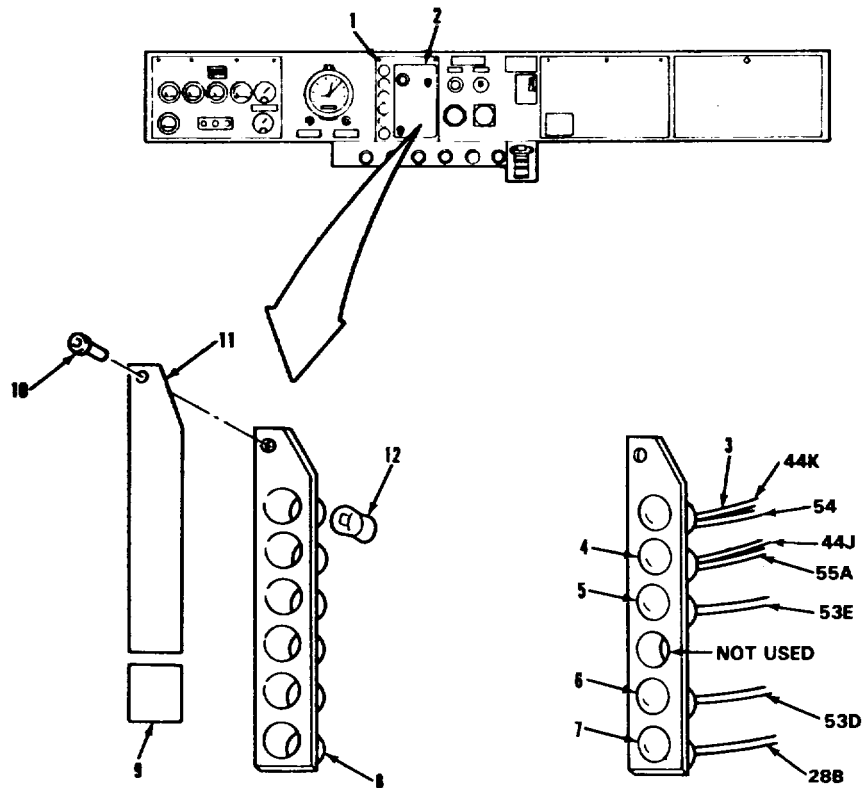

**LEGEND:**

- |  |  |
|--|--|
| <ul style="list-style-type: none"> <li>1. QUARTER-TURN SCREW (2)</li> <li>2. INSTRUMENT PANEL</li> <li>3. ENGINE OIL SOCKET AND WIRE ASSEMBLY</li> <li>4. ENGINE TEMPERATURE SOCKET AND WIRE ASSEMBLY</li> <li>5. DIFFETENTIAL LOCKOUT SOCKET AND WIRE ASSEMBLY</li> </ul> | <ul style="list-style-type: none"> <li>6. PARK BRAKE SOCKET AND WIRE ASSEMBLY</li> <li>7. HIGH BEAM SOCKET AND WIRE ASSEMBLY</li> <li>8. TUBE ASSEMBLY</li> <li>9. LENS</li> <li>10. RIVET (2)</li> <li>11. LENS</li> <li>12. MARKER LAMP (5)</li> </ul> |
|--|--|

**ELECTRICAL SYSTEM.**

<b>3-87. WARNING AND INDICATOR LAMPS REPLACEMENT (Continued).</b>		
<b>LOCATION/ITEM</b>	<b>ACTION</b>	<b>REMARKS</b>
<b><u>D. TUBE ASSEMBLY AND LENSES INSTALLATION (Continued)</u></b>		
15. High beam socket and wire assembly (7), park brake socket and wire assembly (6), differential lockout socket and wire assembly (5), engine temperature socket and wire assembly (4), and engine oil socket and wire assembly (3).	Install in item (8).	Install according to identification tag from step 7.
<b><u>E. OPERATIONAL CHECK.</u></b>		
16. Instrument panel	Raise. (2).	
17. Two quarter-turn screws (1).	Tighten.	
18. Switch (as required).	Turn on and verify operation of new bulb.	Refer to TM 9-2320-283-10.
<b>NOTE</b>		
Follow-on maintenance action required:		
None.		

ELECTRICAL SYSTEM.

3-87. WARNING AND INDICATOR LAMPS REPLACEMENT (Continued).

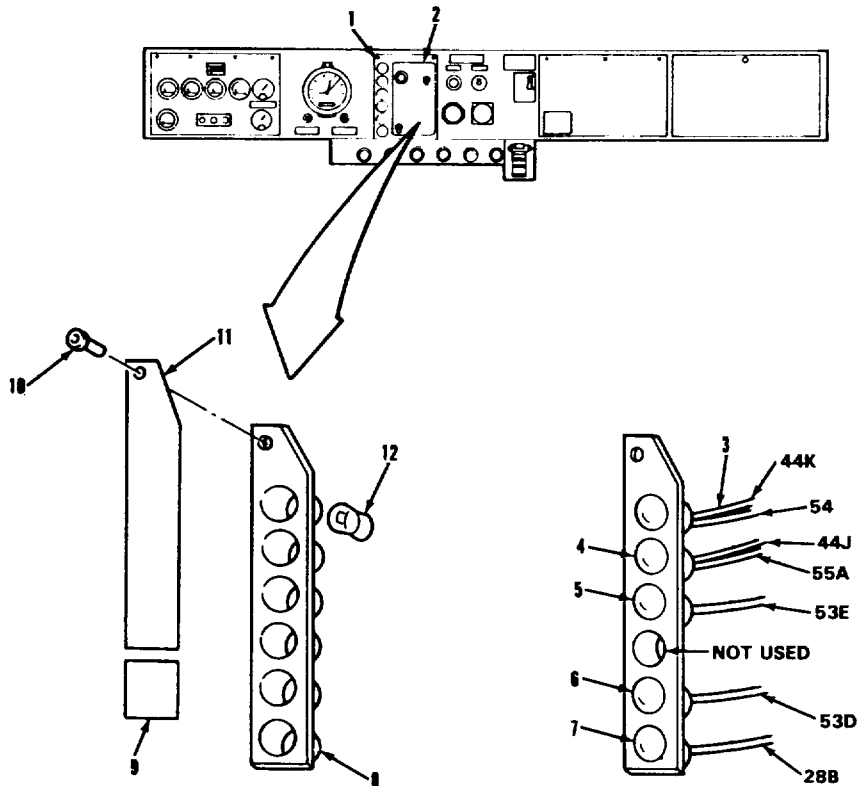

LEGEND:

- |  |  |
|--|--|
| <ul style="list-style-type: none"> <li>1. QUARTER-TURN SCREW (2)</li> <li>2. INSTRUMENT PANEL</li> <li>3. ENGINE OIL SOCKET AND WIRE ASSEMBLY</li> <li>4. ENGINE TEMPERATURE SOCKET AND WIRE ASSEMBLY</li> <li>5. DIFFERENTIAL LOCKOUT SOCKET AND WIRE ASSEMBLY</li> </ul> | <ul style="list-style-type: none"> <li>6. PARK BRAKE SOCKET AND WIRE ASSEMBLY</li> <li>7. HIGH BEAM SOCKET AND WIRE ASSEMBLY</li> <li>8. TUBE ASSEMBLY</li> <li>9. LENS</li> <li>10. RIVET (2)</li> <li>11. LENS</li> <li>12. MARKER LAMP (5)</li> </ul> |
|--|--|

**ELECTRICAL SYSTEM.**

**3-88. THREE POSITION ENGINE RETARDER SWITCH REPLACEMENT**

**THIS TASK COVERS**

- a. Removal.
- b. Installation.
- c. Operational Check.

<b>INITIAL SETUP</b>		
<u>APPLICABLE CONFIGURATIONS</u> All.	<u>EQUIPMENT CONDITION PARAGRAPH</u> 3-120.	<u>CONDITION DESCRIPTION</u> Battery power disconnected.
<u>TEST EQUIPMENT</u> None.		
<u>SPECIAL TOOLS</u> None.		
<u>MATERIALS/PARTS (P/N)</u> None.		
<u>PERSONNEL REQUIRED</u> One (MOS-63S).	<u>SPECIAL ENVIRONMENTAL CONDITIONS</u> Vehicle parked on level ground.	
<u>REFERENCES (TM)</u> None.	<u>GENERAL SAFETY INSTRUCTIONS</u> Engine off. Transmission in neutral. Park brake set.	
<u>TROUBLESHOOTING REFERENCES</u> Paragraph 2-11.		



ELECTRICAL SYSTEM.

3-88. THREE POSITION ENGINE RETARDER SWITCH REPLACEMENT (Continued).

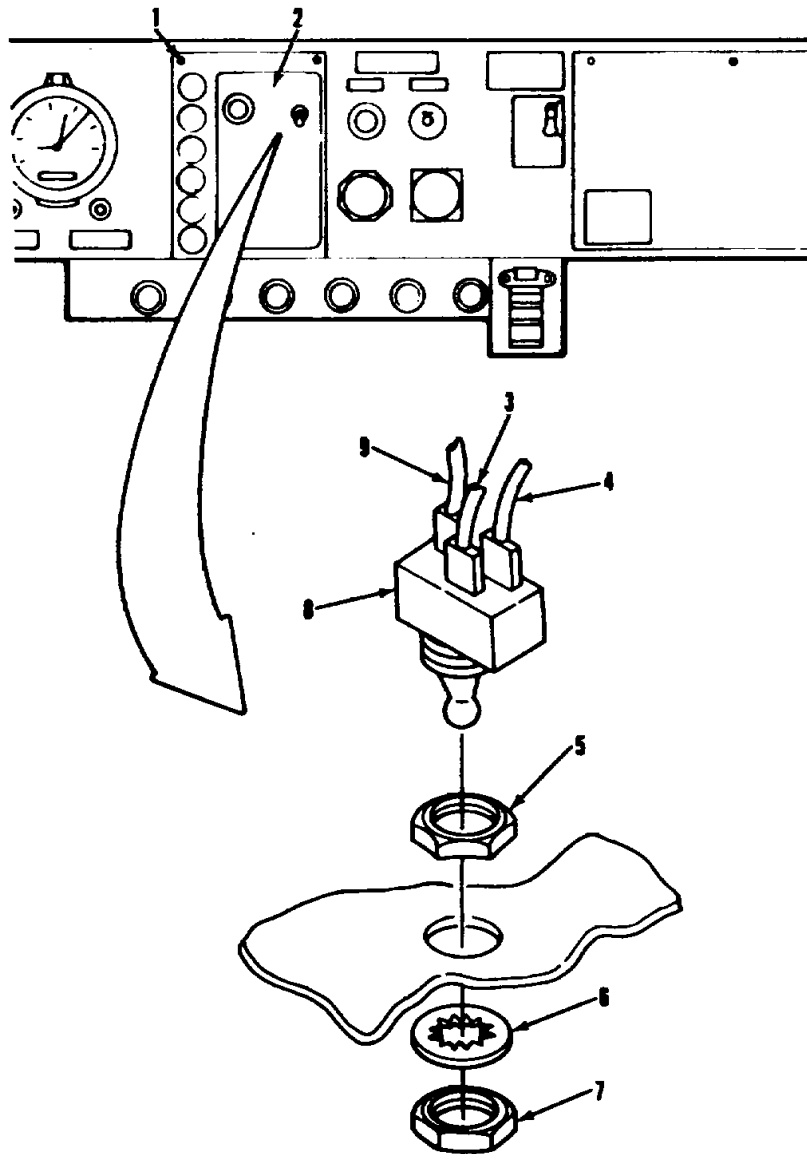

LEGEND:

- |                           |  |
|---------------------------|--|
| 1. QUARTER-TURN SCREW (2) | 6. LOCKWASHER                            |
| 2. INSTRUMENT PANEL       | 7. HEX NUT                               |
| 3. WIRE (52G)             | 8. THREE POSITION ENGINE RETARDER SWITCH |
| 4. WIRE (52F)             | 9. WIRE (52J)                            |
| 5. ADJUSTING NUT          |  |

3-505

## ELECTRICAL SYSTEM.

3-88. THREE POSITION ENGINE RETARDER SWITCH REPLACEMENT (Continued).		
LOCATION/ITEM	ACTION	REMARKS
<b><u>A. REMOVAL.</u></b>		
1. Two screws (1)	Loosen.	
2. Instrument panel (2).	Lower.	
3. Wire (3), wire (4), and wire (9).	Remove	Tag for identification.
4. Hex nut (7) and lockwasher (6).	Remove.	
5. Three position engine retarder switch (8).	Remove.	
6. Adjusting nut (5). Remove.		
<b><u>B. INSTALLATION.</u></b>		
7. Adjusting nut (5).	Install and adjust to proper depth on item (8) to allow for installation of items (6) and (7).	
8. Three position engine retarder switch (8).	Aline and install.	
9. Hex nut (7) and lockwasher (6).	Install and tighten.	
10. Wire (3), wire (4), and wire (9)	Install	Connect according to identification tag from step 3.
11. Instrument panel (2).	Raise into position.	
12. Two screws (1)	Tighten.	
13. Batteries	Connect	Refer to paragraph 3-120.

ELECTRICAL SYSTEM.

3-88. THREE POSITION ENGINE RETARDER SWITCH REPLACEMENT (Continued).

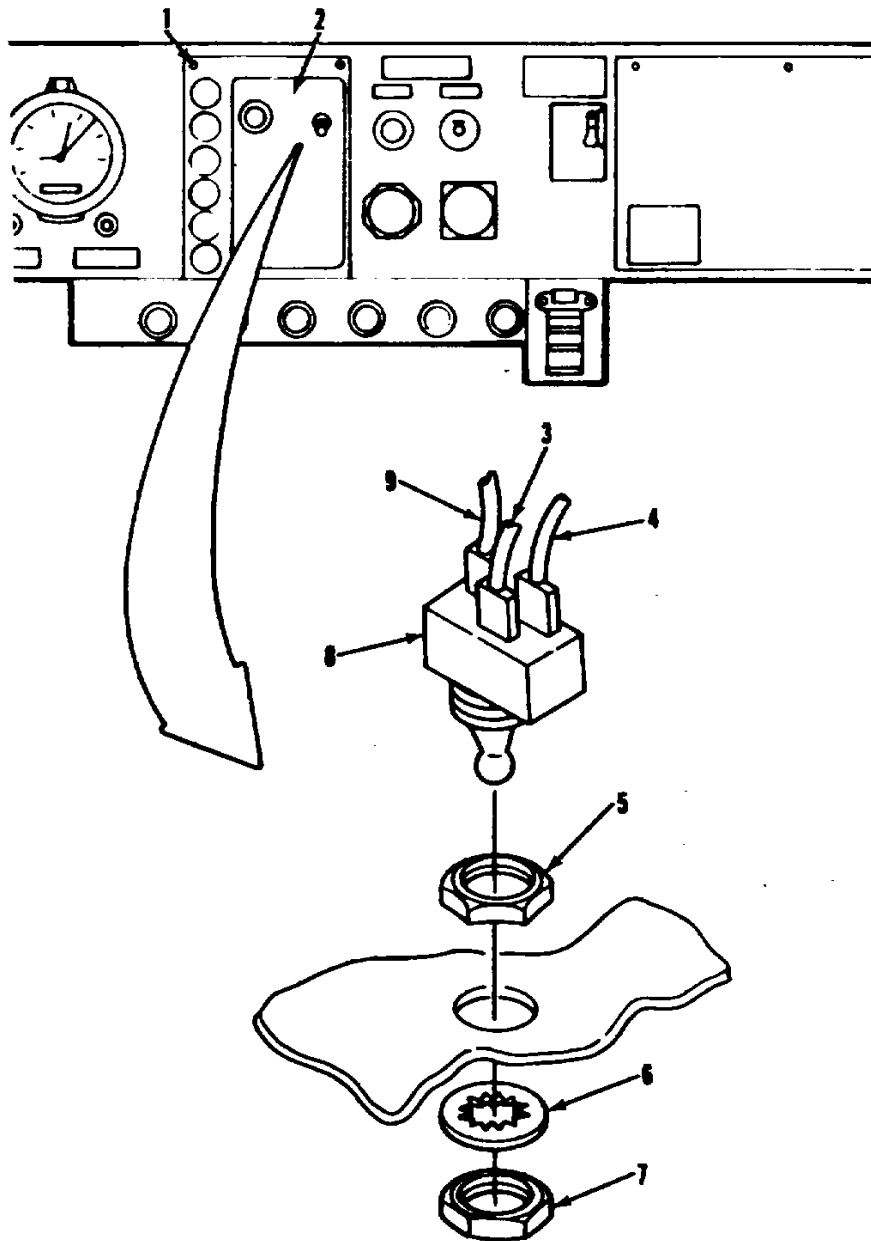

LEGEND:

- |                           |  |
|---------------------------|--|
| 1. QUARTER-TURN SCREW (2) | 6. LOCK WASHER                           |
| 2. INSTRUMENT PANEL       | 7. HEX NUT                               |
| 3. WIRE (52G)             | 8. THREE POSITION ENGINE RETARDER SWITCH |
| 4. WIRE (52F)             | 9. WIRE (52J)                            |
| 5. ADJUSTING NUT          |  |

**ELECTRICAL SYSTEM.**

<b>3-88. THREE POSITION ENGINE RETARDER SWITCH REPLACEMENT (Continued).</b>		
<b>LOCATION/ITEM</b>	<b>ACTION</b>	<b>REMARKS</b>
<b><u>C. OPERATIONAL CHECK. I</u></b>		
14. Engine	Start	Refer to TM 9-2320-283-10.
15. Three position engine retarder switch (8).	Set item (8) to HI, MED, LO to TM 9-2320-283-10).	Verify operation. (Refer
<p><b>NOTE</b>                      Follow-on maintenance action required:                      None.</p>		
<p><b>3-508</b></p>		

ELECTRICAL SYSTEM.

3-88. THREE POSITION ENGINE RETARDER SWITCH REPLACEMENT (Continued).

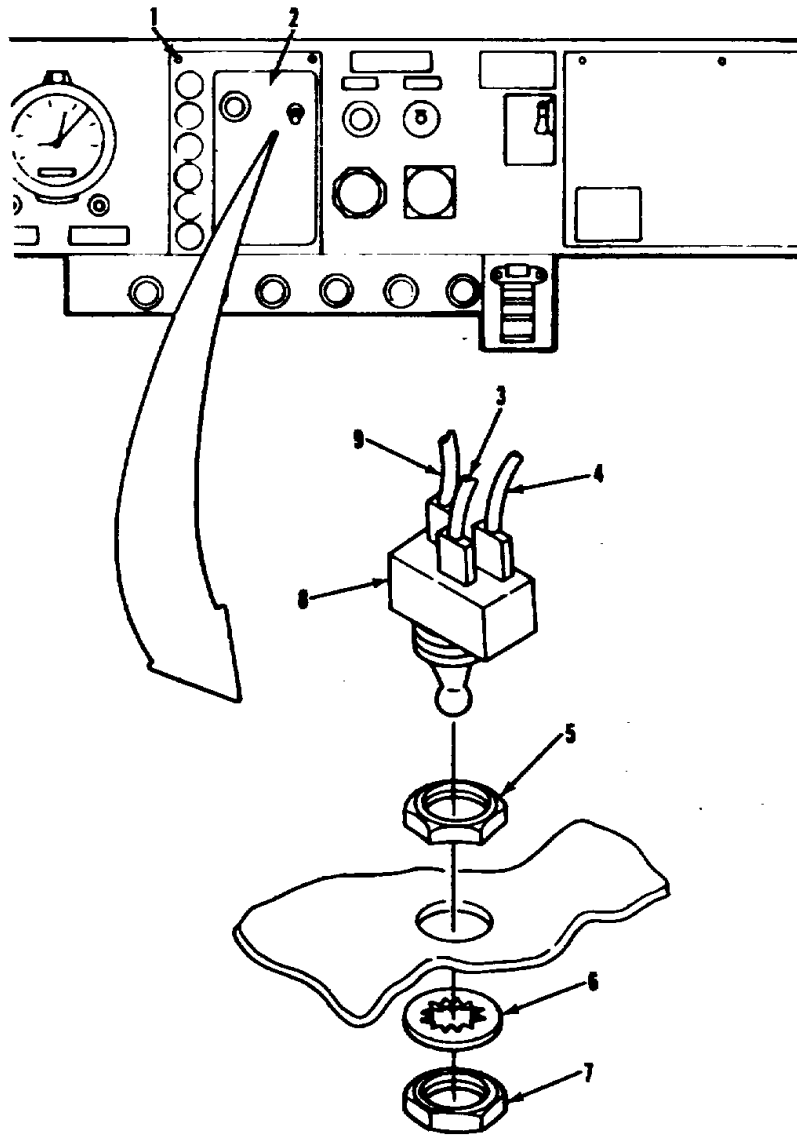

LEGEND:

- |                           |  |
|---------------------------|--|
| 1. QUARTER-TURN SCREW (2) | 6. LOCKWASHER                            |
| 2. INSTRUMENT PANEL       | 7. HEX NUT                               |
| 3. WIRE (52G)             | 8. THREE POSITION ENGINE RETARDER SWITCH |
| 4. WIRE (52F)             | 9. WIRE (52J)                            |
| 5. ADJUSTING NUT          |  |

**ELECTRICAL SYSTEM.**

<b>3-89. ENGINE RETARDER SWITCH REPLACEMENT</b>		
<u>THIS TASK COVERS</u>		
<ul style="list-style-type: none"> <li>a. Removal.</li> <li>b. Installation.</li> <li>c. Operational Check.</li> </ul>		
<u>INITIAL SETUP</u>		
<u>APPLICABLE CONFIGURATIONS</u>	<u>EQUIPMENT CONDITION PARAGRAPH</u>	<u>CONDITION DESCRIPTION</u>
All	3-120	Battery power disconnected.
<u>TEST EQUIPMENT</u>		
None.		
<u>SPECIAL TOOLS</u>		
None.		
<u>MATERIALS/PARTS (P/N)</u>		
Pin, cotter (24617) 137137.		
<u>PERSONNEL REQUIRED</u>	<u>SPECIAL ENVIRONMENTAL CONDITIONS</u>	
One (MOS-63S)	Vehicle parked on level ground.	
<u>REFERENCES (TM)</u>	<u>GENERAL SAFETY INSTRUCTIONS</u>	
TM 9-2320-283-10 TM 9-2320-283-20P	Engine off. Transmission in neutral. Park brake set.	
<u>TROUBLESHOOTING REFERENCES</u>		
Paragraph 2-11.		

ELECTRICAL SYSTEM.

3-89. ENGINE RETARDER FOOT SWITCH REPLACEMENT (Continued).

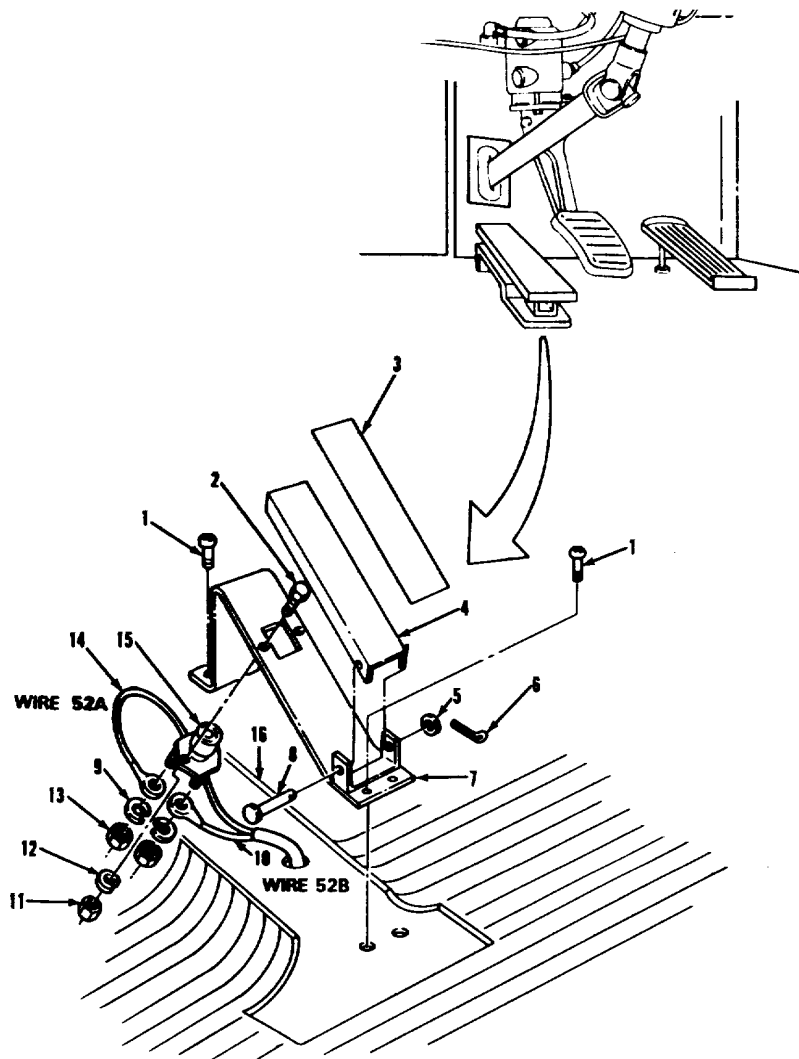

LEGEND:

- |               |                                 |
|---------------|---------------------------------|
| 1. SCREW (4)  | 9. LOCKWASHER (2)               |
| 2. SCREW (2)  | 10. WIRE (52B)                  |
| 3. PAD        | 11. NUT (2)                     |
| 4. PEDAL      | 12. LOCKWAHSER (2)              |
| 5. WASHER     | 13. NUT (2)                     |
| 6. COTTER PIN | 14. WIRE (52A)                  |
| 7. BASE       | 15. ENGINE RETARDER FOOT SWITCH |
| 8. CLEVIS PIN | 16. FLOOR MAT                   |

## ELECTRICAL SYSTEM.

<b>3-89. ENGINE RETARDER FOOT SWITCH REPLACEMENT (Continued).</b>		
<b>LOCATION/ITEM</b>	<b>ACTION</b>	<b>REMARKS</b>
<b><u>A. REMOVAL.</u></b>		
1. Floor mat (16)	Fold back from corner.	
2. Cotter pin (6) and washer (5).	Remove	Discard item (6).
3. Clevis pin (8)	Remove	Inspect for distortion.
4. Pedal (4)	Remove	Discard if damaged.
5. Pad (3)	Inspect for wear	If worn, scrape off and replace with new item (3). Remove backing before installing.
6. Two nuts (13) and two lockwashers (9).	Remove.	
7. Wire (10) and wire (14).	Remove	Tag for identification.
8. Two nuts (11), two lockwashers (12), and two screws (2).	Remove.	
9. Engine retarder foot switch (15).	Remove.	
10. Four screws (1)	Remove.	
11. Base (7)	Remove.	
<b><u>B. INSTALLATION</u></b>		
12. Base (7)	Place in position.	
13. Four screws (1)	Install and tighten.	
14. Engine retarder foot switch (15).	Hold in position.	



ELECTRICAL SYSTEM.

3-88. ENGINE RETARDER FOOT SWITCH REPLACEMENT (Continued).

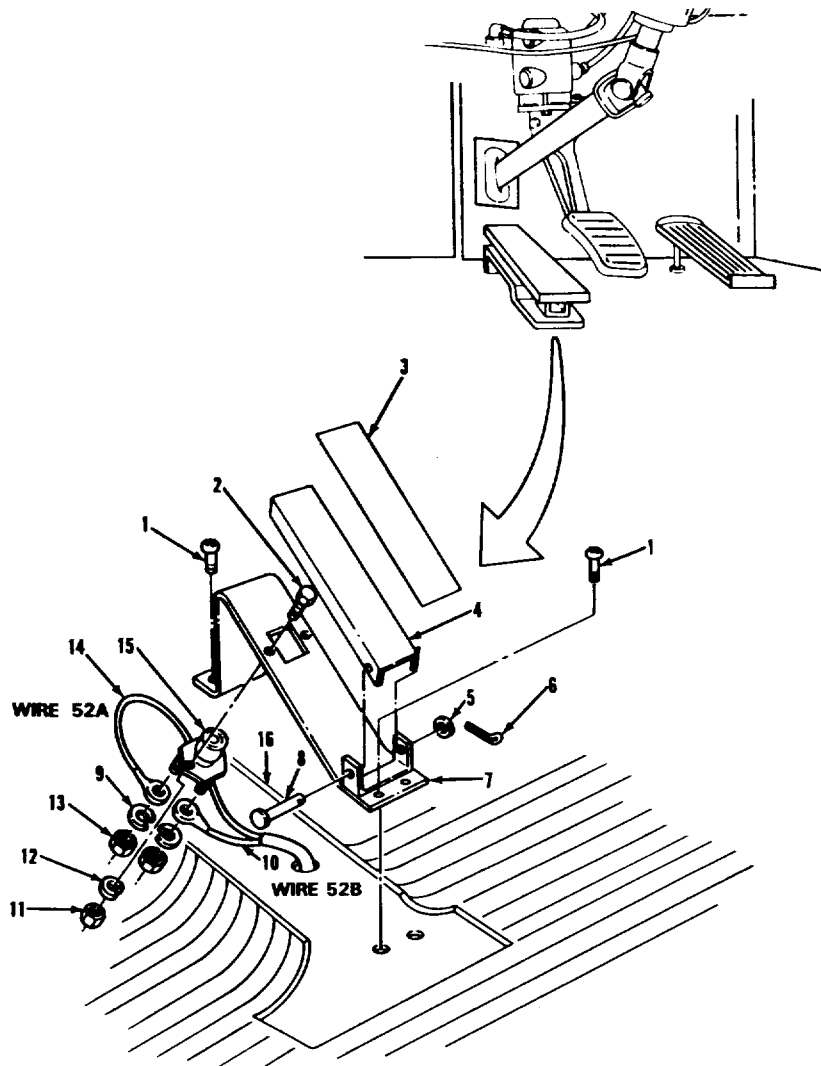

LEGEND:

- |               |                                 |
|---------------|---------------------------------|
| 1. SCREW (4)  | 9. LOCKWASHER (2)               |
| 2. SCREW (2)  | 10. WIRE (52B)                  |
| 3. PAD        | 11. NUT (2)                     |
| 4. PEDAL      | 12. LOCKWASHER (2)              |
| 5. WASHER     | 13. NUT (2)                     |
| 6. COTTER PIN | 14. WIRE (52A)                  |
| 7. BASE       | 15. ENGINE RETARDER FOOT SWITCH |
| 8. CLEVIS PIN | 16. FLOOR MAT                   |

**ELECTRICAL SYSTEM.**

<b>3-89. ENGINE RETARDER FOOT SWITCH REPLACEMENT (Continued).</b>		
<b>LOCATION/ITEM</b>	<b>ACTION</b>	<b>REMARKS</b>
<b>B. INSTALLATION (Continued).</b>		
15. Two nuts (11), two lockwashers (12), and two screws (2).	Install and tighten.	
16. Wire (10) and wire (14)	Install	Connect according to identification tag from step 7.
17. Two lockwashers (9) and two nuts (13).	Install and tighten.	
18. Pedal (4)	Place in position and aline with holes in item (7).	
19. Clevis pin (8) through item (4).	Insert into item (7) and	
20. Washer (5) and new cotter pin (6)	Install	Bend end of item (6) to keep it from falling out.
21. Floor mat (16)	Replace.	
22. Batteries	Connect	Refer to paragraph 3-120.
<b><u>C. OPERATIONAL CHECK.</u></b>		
23. Engine	Start up	Refer to TM 9-2320-283-10.
24. Engine retarder foot switch (15)	Push with foot	Verify operation. (Refer to TM 9-2320-283-10).
<b>NOTE</b>		
Follow-on maintenance action required:		
None.		
<b>3-514</b>		

ELECTRICAL SYSTEM.

3-89. ENGINE RETARDER FOOT SWITCH REPLACEMENT (Continued).

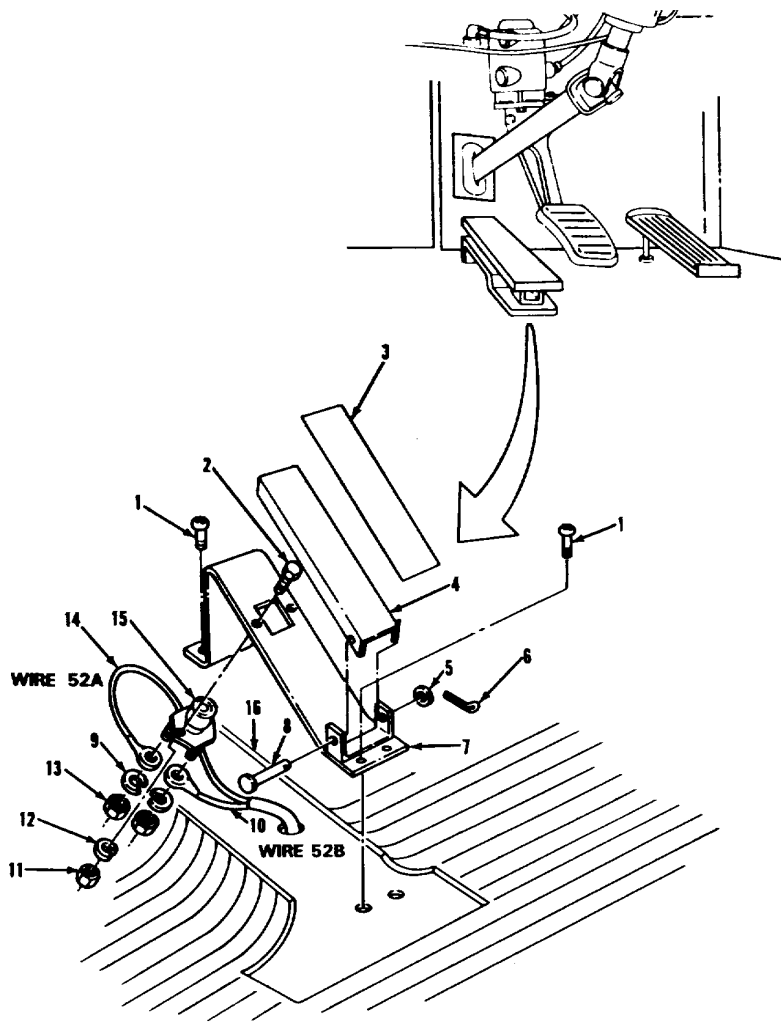

LEGEND:

- |               |                                 |
|---------------|---------------------------------|
| 1. SCREW (4)  | 9. LOCKWASHER (2)               |
| 2. SCREW (2)  | 10. WIRE (52B)                  |
| 3. PAD        | 11. NUT (2)                     |
| 4. PEDAL      | 12. LOCKWASHER (2)              |
| 5. WASHER     | 13. NUT (2)                     |
| 6. COTTER PIN | 14. WIRE (52A)                  |
| 7. BASE       | 15. ENGINE RETARDER FOOT SWITCH |
| 8. CLEVIS PIN | 16. FLOOR MAT                   |

**ELECTRICAL SYSTEM.**

<b>3-90. FUEL PUMP ENGINE RETARDER SWITCH REPLACEMENT</b>		
THIS TASK COVERS		
a. Removal.	d. Installation.	
b. Disassembly.	e. Operational Check.	
c. Assembly.		
<u>INITIAL SETUP</u>		
<u>APPLICABLE CONFIGURATIONS</u>	<u>EQUIPMENT CONDITION PARAGRAPH</u>	<u>CONDITION DESCRIPTION</u>
All.	TM 9-2320-283-10.	Left hood panel opened and supported.
<u>TEST EQUIPMENT</u>		
None.		
<u>SPECIAL TOOLS</u>		
None.		
<u>MATERIALS/PARTS (P/N)</u>		
None.		
<u>PERSONNEL REQUIRED</u>	<u>SPECIAL ENVIRONMENTAL CONDITIONS</u>	
One (MOS-63S).	Vehicle parked on level ground.	
<u>REFERENCES (TM)</u>	<u>GENERAL SAFETY INSTRUCTIONS</u>	
TM 9-2320-283-10.	Engine off. Transmission in neutral. Park brake set.	
<u>TROUBLESHOOTING REFERENCES</u>		
Paragraph 2-11.		

ELECTRICAL SYSTEM.

3-90. FUEL PUMP ENGINE RETARDER REPLACEMENT (Continued).

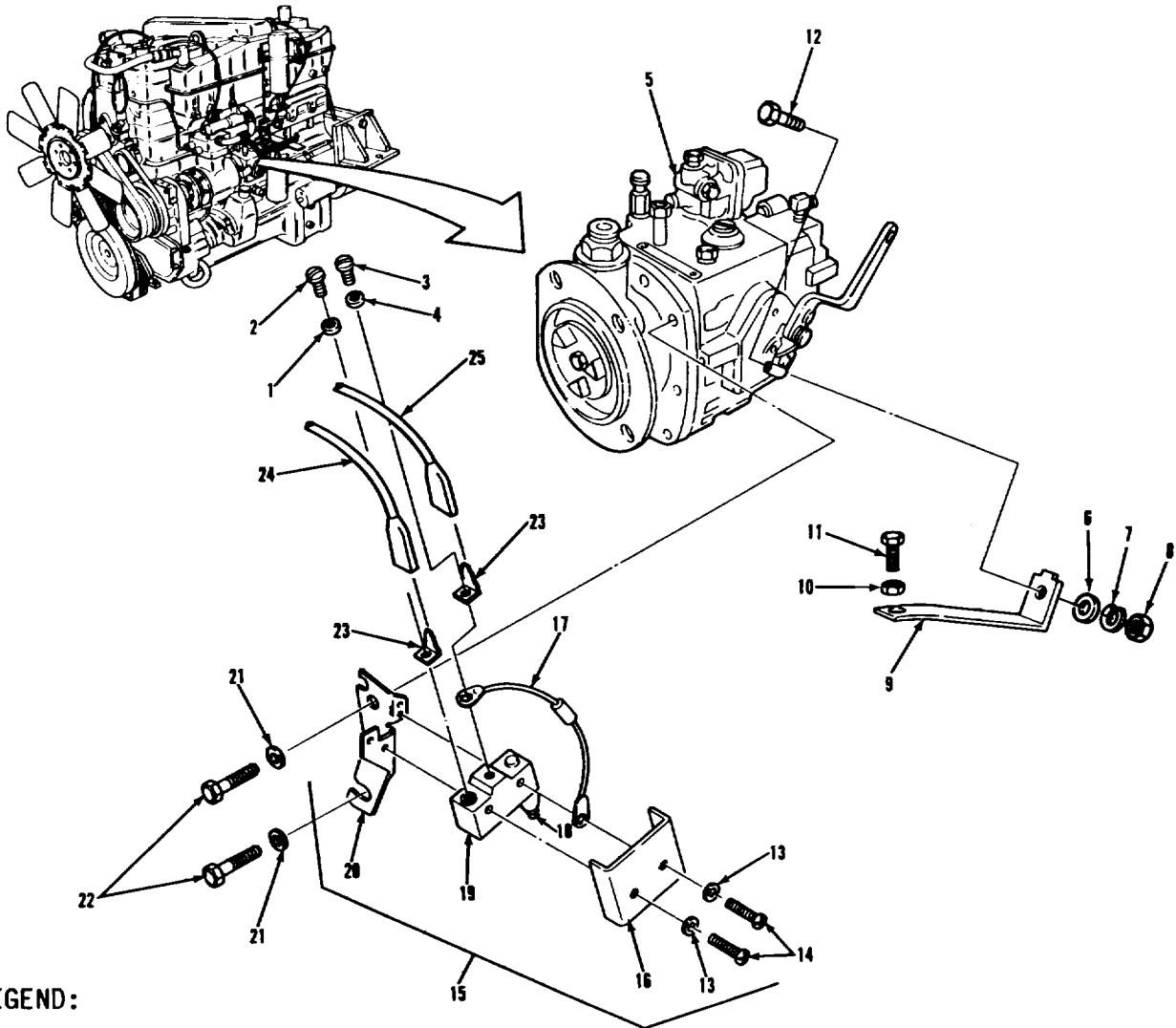

LEGEND:

- |                    |                      |
|--------------------|----------------------|
| 1. LOCKWASHER      | 14. SCREW (2)        |
| 2. SCREW           | 15. SWITCH ASSEMBLY  |
| 3. SCREW           | 16. COVER            |
| 4. LOCKWASHER      | 17. DIODE ASSEMBLY   |
| 5. FUEL PUMP       | 18. ACTUATING BUTTON |
| 6. WASHER          | 19. SWITCH           |
| 7. LOCKWASHER      | 20. BRACKET          |
| 8. NUT             | 21. LOCKWASHER (2)   |
| 9. LEVER           | 22. SCREW (2)        |
| 10. NUT            | 23. TAB (2)          |
| 11. SCREW          | 24. WIRE 52D         |
| 12. SCREW          | 25. WIRE 52E         |
| 13. LOCKWASHER (2) |                      |

TA 237233

## ELECTRICAL SYSTEM.

3-90. FUEL PUMP ENGINE RETARDER REPLACEMENT (Continued).		
LOCATION/ITEM	ACTION	REMARKS
<b>A. REMOVAL.</b>		
1. Wire (24) and wire (25).	Remove	Tag for identification.
2. Two screws (22) and two lockwashers (21).	Loosen.	
3. Switch assembly (15).	Remove from item (5).	
4. Screw (12) and nut (8).	Loosen.	
5. Nut (8), lockwasher (7), and washer (6).	Remove.	
6. Lever (9)	Remove.	
7. Nut (10)	Loosen.	
8. Screw (11)	Remove from item (9).	
9. Nut (10)	Remove from item (11).	
<b>B. DISASSEMBLY.</b>		
10. Two screws (14) and lockwashers (13)	Remove	Note and mark location of mounting holes in item (20).
11. Cover (16)	Remove.	
12. Switch (19)	Remove from item (20).	
13. Screw (2), screw (3), lockwasher (1), and lockwasher (4).	Remove.	
14. Diode (17) end.	Remove	Note location of banded
15. Two tabs (24)	Remove.	

ELECTRICAL SYSTEM.

3-90. FUEL PUMP ENGINE RETARDER REPLACEMENT (Continued).

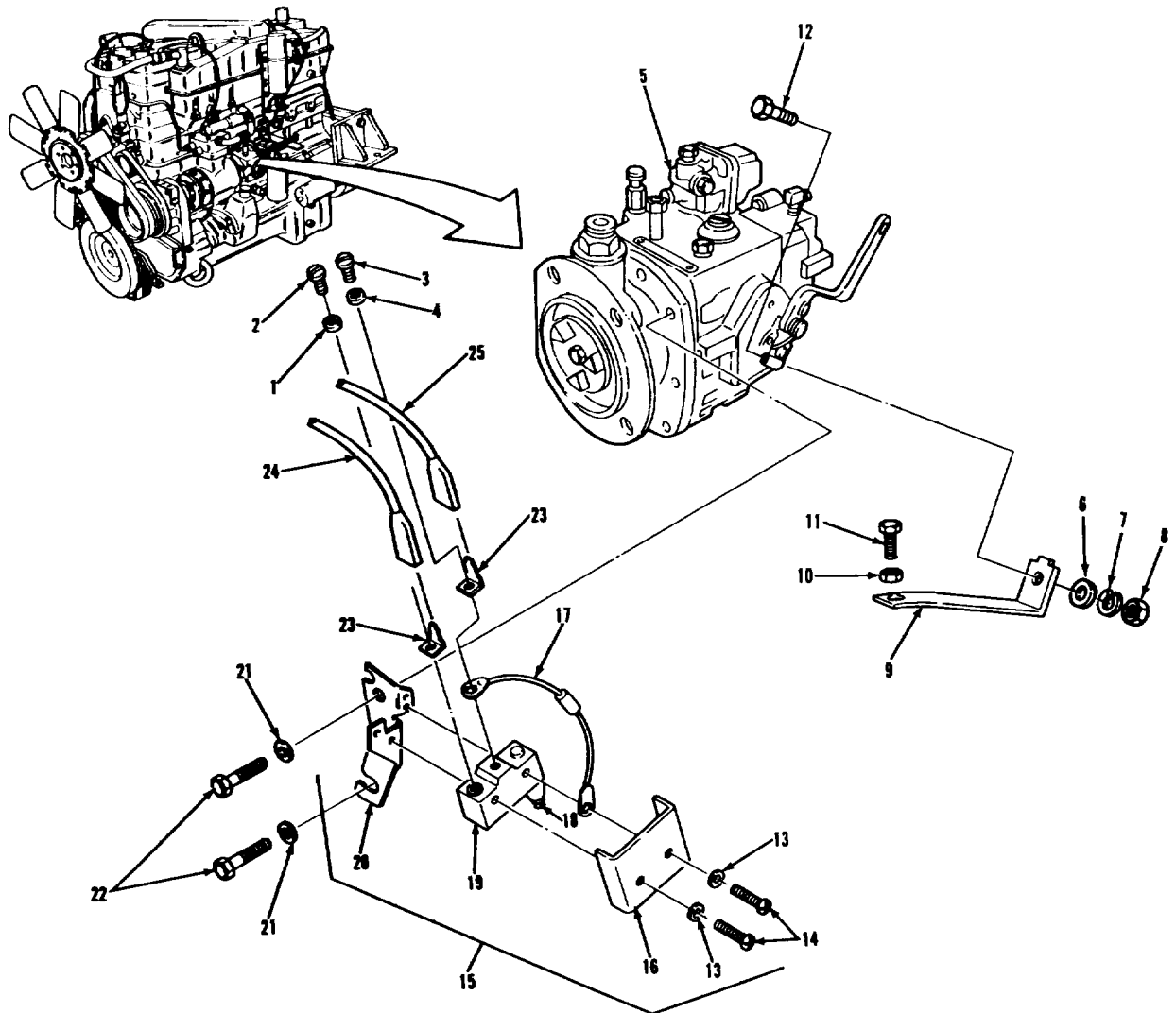

LEGEND:

- |                    |                      |
|--------------------|----------------------|
| 1. LOCKWASHER      | 14. SCREW (2)        |
| 2. SCREW           | 15. SWITCH ASSEMBLY  |
| 3. SCREW           | 16. COVER            |
| 4. LOCKWASHER      | 17. DIODE ASSEMBLY   |
| 5. FUEL PUMP       | 18. ACTUATING BUTTON |
| 6. WASHER          | 19. SWITCH           |
| 7. LOCKWASHER      | 20. BRACKET          |
| 8. NUT             | 21. LOCKWASHER (2)   |
| 9. LEVER           | 22. SCREW (2)        |
| 10. NUT            | 23. TAB (2)          |
| 11. SCREW          | 24. WIRE 52D         |
| 12. SCREW          | 25. WIRE 52E         |
| 13. LOCKWASHER (2) |                      |

TA 237234

## ELECTRICAL SYSTEM.

3-90. FUEL PUMP ENGINE RETARDER REPLACEMENT (Continued).		
LOCATION/ITEM	ACTION	REMARKS
<b>C. ASSEMBLY.</b>		
16. Screw (3), lock-washer (4), diode (17), and tab (23).	Install item (3) through items (4), (17), (23), and tighten	Note location of banded end of item (17) and install accordingly.
17. Screw (2), lock-washer (1), and tab (23).	Install and tighten.	
18. Bracket (20), switch (19), and cover (16).	Aline mounting holes.	
19. Two screws (14) and lockwashers (13)	Install through item (16), terminal of item (17), item (19), and item (20). Tighten items (14).	
<b>D. INSTALLATION.</b>		
20. Switch assembly (15)	Move into position on item (5). Aline mounting slots with two items (22). Make sure item (20) fits between item (5) and two items (21). Tighten two items (22).	
21. Nut (10)	Install halfway onto item (11).	
22. Screw (11)	Install halfway onto item (9).	
23. Lever (9)	Install. Secure with items (6), (7), (8), and (12).	
24. Screw (12) and	Tighten. nut (8).	
<b>3-520</b>		



ELECTRICAL SYSTEM.

3-90. FUEL PUMP ENGINE RETARDER REPLACEMENT (Continued).

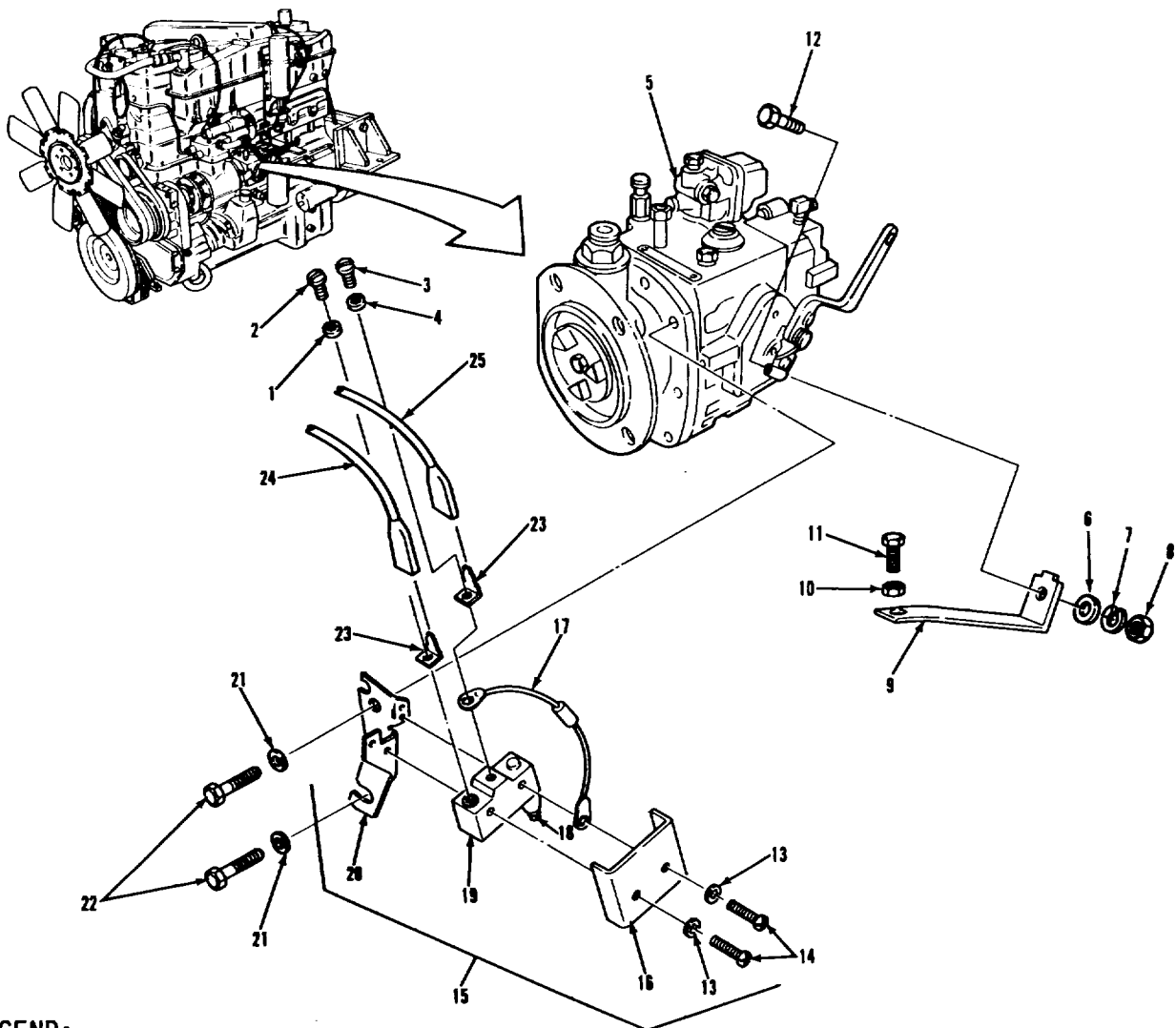

LEGEND:

- |                    |                      |
|--------------------|----------------------|
| 1. LOCKWASHER      | 14. SCREW (2)        |
| 2. SCREW           | 15. SWITCH ASSEMBLY  |
| 3. SCREW           | 16. COVER            |
| 4. LOCKWASHER      | 17. DIODE ASSEMBLY   |
| 5. FUEL PUMP       | 18. ACTUATING BUTTON |
| 6. WASHER          | 19. SWITCH           |
| 7. LOCKWASHER      | 20. BRACKET          |
| 8. NUT             | 21. LOCKWASHER (2)   |
| 9. LEVER           | 22. SCREW (2)        |
| 10. NUT            | 23. TAB (2)          |
| 11. SCREW          | 24. WIRE 52D         |
| 12. SCREW          | 25. WIRE 52E         |
| 13. LOCKWASHER (2) |                      |

TA 237235

**ELECTRICAL SYSTEM.**

<b>3-90. FUEL PUMP ENGINE RETARDER REPLACEMENT (Continued).</b>		
<b>LOCATION/ITEM</b>	<b>ACTION</b>	<b>REMARKS</b>
<b><u>D. INSTALLATION (Continued).</u></b>		
<b>NOTE</b>		
<b>It may be necessary to bend the lever slightly to obtain proper contact between the actuating button and the head of the screw.</b>		
25. Screw (11)	Turn clockwise or counter-clockwise until head touches item (18). Continue to turn until click is heard from item (19).	Make sure that throttle arm is in idle fuel position.
26. Nut (10) Tighten item (10) against item (9).	Hold item (11) in place.	
27. Wire (24) and wire (25)	Install tag from step 1.	Connect according to
<b><u>E. OPERATIONAL CHECK.</u></b>		
28. Engine	Start	Refer to TM 9-2320-283-10.
29. Switch assembly (15)	Verify operation	Refer to TM 9-2320-283-10.
<b>NOTE</b>		
<b>Follow-on maintenance action required:</b>		
<b>Lower left hood panel (TM 9-2320283-10).</b>		

ELECTRICAL SYSTEM.

**3-90. FUEL PUMP ENGINE RETARDER REPLACEMENT (Continued)**

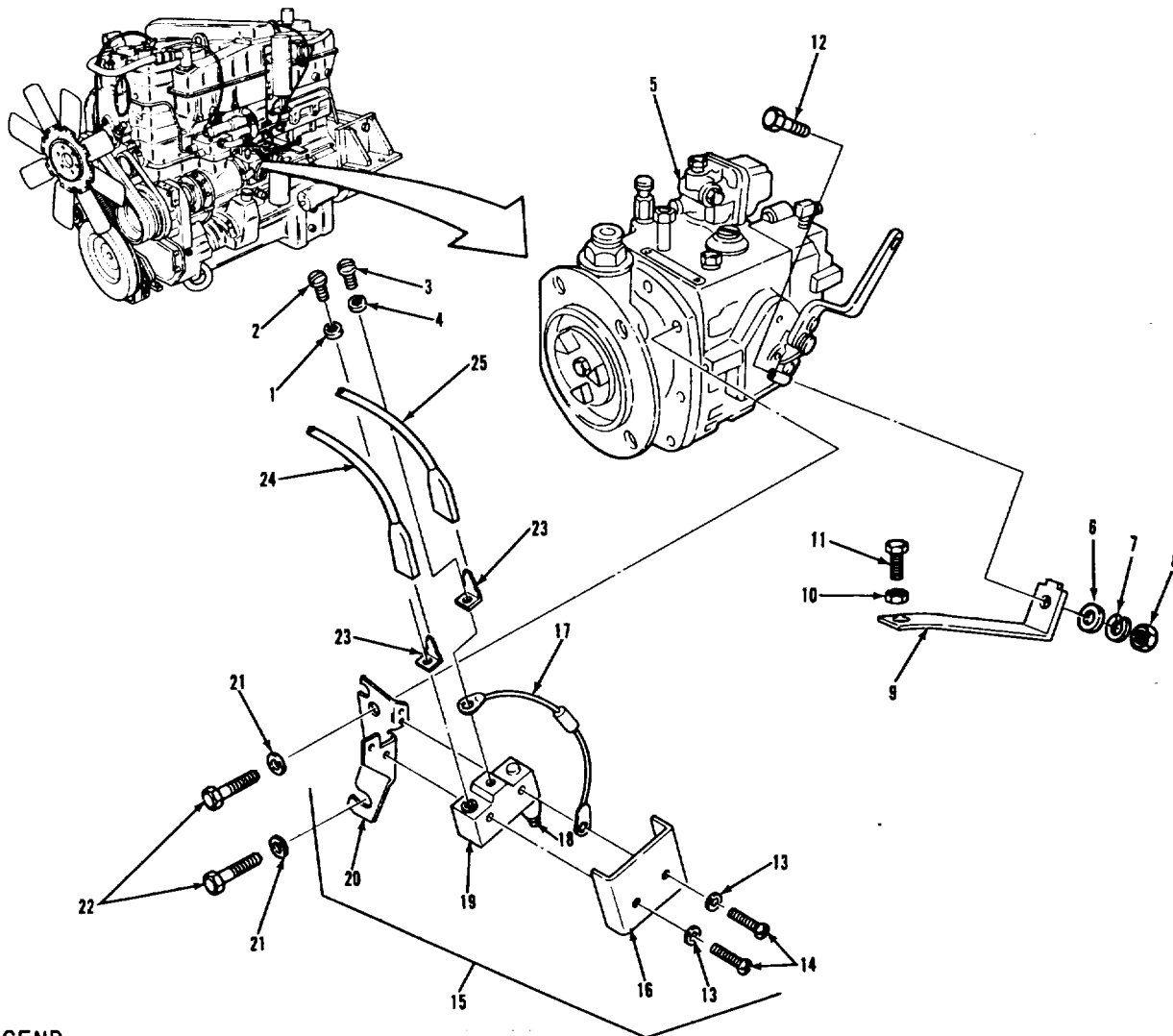

LEGEND:

- |                    |                      |
|--------------------|----------------------|
| 1. LOCKWASHER      | 14. SCREW (2)        |
| 2. SCREW           | 15. SWITCH ASSEMBLY  |
| 3. SCREW           | 16. COVER            |
| 4. LOCKWASHER      | 17. DIODE ASSEMBLY   |
| 5. FUEL PUMP       | 18. ACTUATING BUTTON |
| 6. WASHER          | 19. SWITCH           |
| 7. LOCKWASHER      | 20. BRACKET          |
| 8. NUT             | 21. LOCKWASHER (2)   |
| 9. LEVER           | 22. SCREW (2)        |
| 10. NUT            | 23. TAB (2)          |
| 11. SCREW          | 24. WIRE 52D         |
| 12. SCREW          | 25. WIRE 52E         |
| 13. LOCKWASHER (2) |                      |

TA 237236

**ELECTRICAL SYSTEM.**

**3-91. HEADLAMP ASSEMBLY REPLACEMENT.**

**THIS TASK COVERS**

- a. Removal.
- b. Installation.
- c. Operational Check.

**INITIAL SETUP**

APPLICABLE CONFIGURATIONS  
All.

EQUIPMENT CONDITION  
PARAGRAPH  
TM 9-2320-283-10.

CONDITION DESCRIPTION  
Headlamp switch off.

TEST EQUIPMENT  
None.

SPECIAL TOOLS  
None.

MATERIALS/PARTS (P/N)  
None.

PERSONNEL REQUIRED  
One (MOS-63S).

SPECIAL ENVIRONMENTAL CONDITIONS  
None.

REFERENCES (TM)  
TM 9-2320-283-10.

GENERAL SAFETY INSTRUCTIONS  
Engine off.  
Park brake set.  
Transmission in neutral.

TROUBLESHOOTING REFERENCES  
Paragraph 2-11.

ELECTRICAL SYSTEM.

**3-91. HEADLAMP ASSEMBLY REPLACEMENT (Continued)**

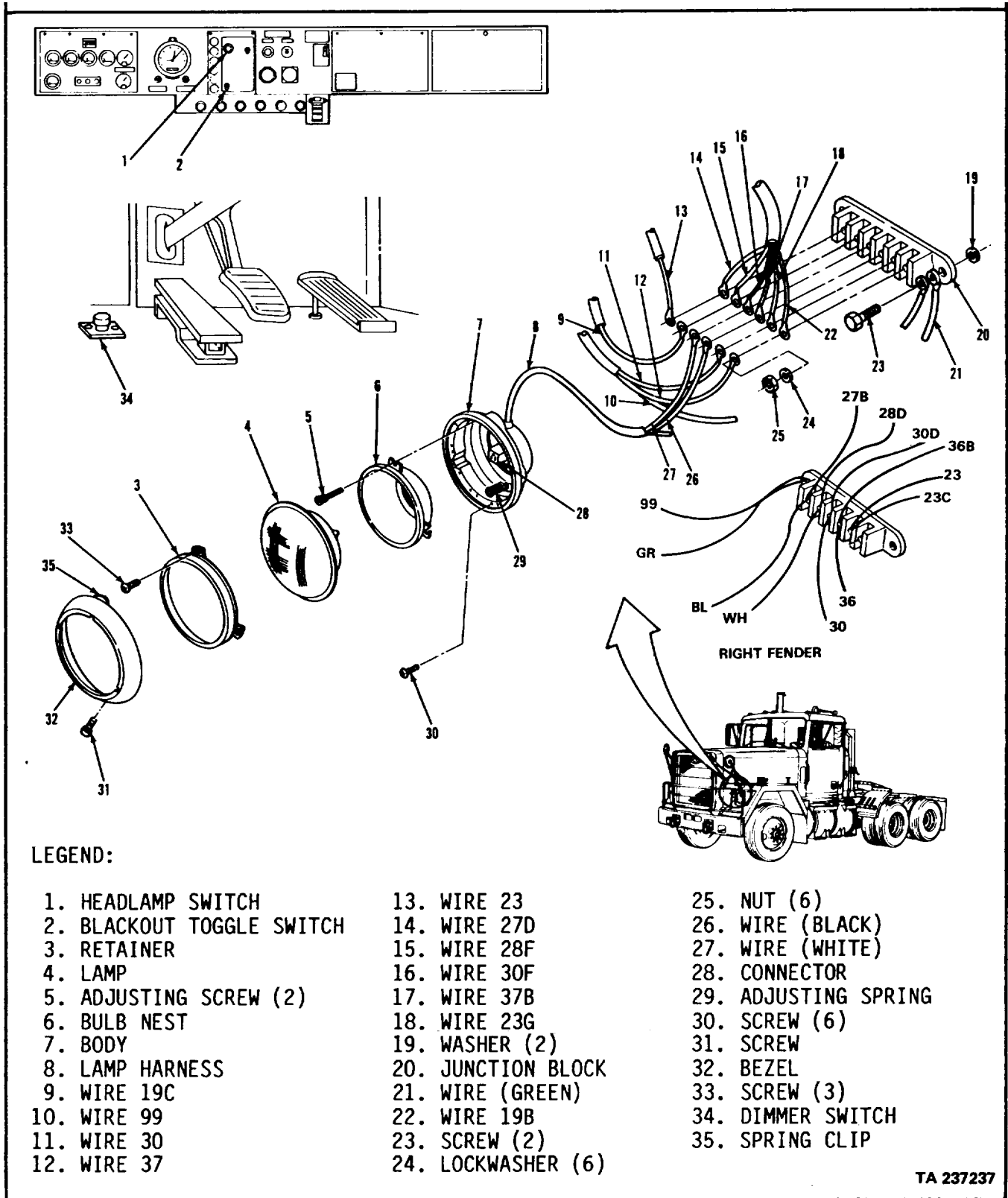

3-91. HEADLAMP ASSEMBLY REPLACEMENT (Continued)		
LOCATION/ITEM	ACTION	REMARKS
<b>A. REMOVAL</b>		
<b>NOTE</b>		
	Replacement of the headlamp assembly is the same for both sides. If only lamp is being replaced, do steps 1, 2, 3, 4, 18, 19, 20, 21, 22, 23, and 24.	
1. Screw (31)	Remove.	
2. Bezel (32)	Remove by pushing up and pulling outward to release spring clip (35) at top.	
<b>NOTE</b>		
	Do not remove adjusting spring and two adjusting screws which hold bulb nest and body together, otherwise headlamp realignment will become necessary.	
3. Three screws (33)	a. Remove	Hold item (4) to prevent it from falling out while removing three items (33) and item (3). Note position of mounting ears on item (3) for reassembly.
4. Lamp (4)	b. Remove item (3). Disconnect item (28) and remove.	
5. Six screws (30)	Remove.	
6. Bulb nest (6) and body (7).	Remove as an assembly.	
7. Six nuts (25) and six lockwashers (24).	Remove.	

ELECTRICAL SYSTEM.

3-91. HEADLAMP ASSEMBLY REPLACEMENT (Continued)

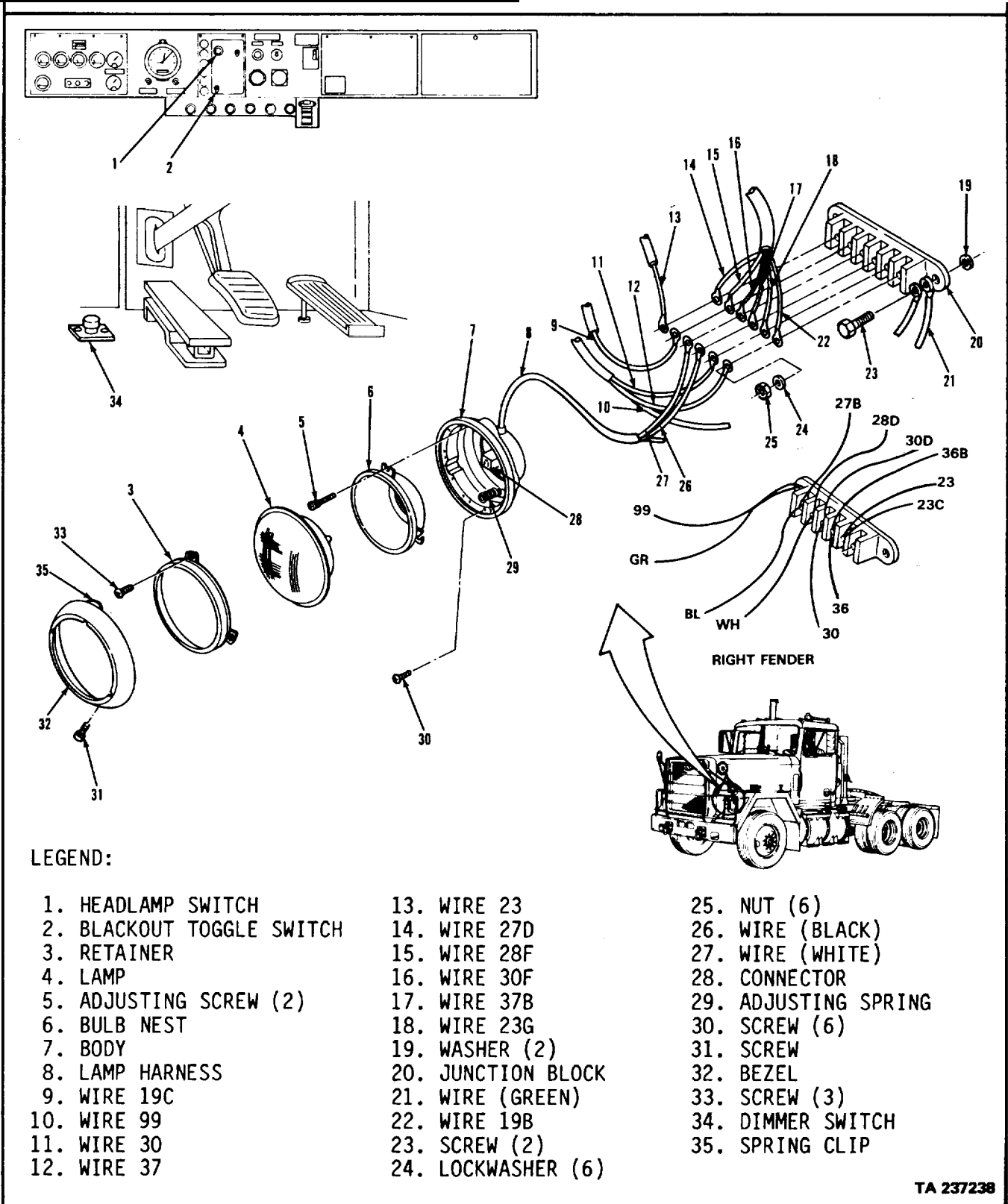

TA 237238

**ELECTRICAL SYSTEM.**

<b>3-91. HEADLAMP ASSEMBLY REPLACEMENT (Continued).</b>		
<b>LOCATION/ITEM</b>	<b>ACTION</b>	<b>REMARKS</b>
<b><u>A. REMOVAL (Continued). I</u></b>		
8. Wire (9), wire (11), wire (12), wire (13), wire (14), wire (15), wire (16), wire (17), wire (18), wire (22), wire (26), and wire (27).	Remove	Tag for identification.
9. Two screws (23)	Remove.	
10. wire (21).	Wire (10) and	Remove.
11. (20) and two washers (19).	Junction block	Remove.
12. Lamp harness (8)	Remove from item (7).	
<b><u>B. INSTALLATION. I</u></b>		
13. Lamp harness (8)	Install on item (7).	
14. Junction block (20) two screws (23), two washers (19), wire (10), and wire (21)	Hold in position and install item (21) and item (10) on one item (23). Secure with two items (23) and two items (19)	Make sure both items (19) are between fender and back of mounting holes in item (20), one on each side. Connect according to identification tag from step 10.
15. Wire (9), wire (11), wire (12), wire (13), wire (14), wire (15), wire (16), wire (17), wire (18), wire (22), wire (26), and wire (27).	Install on item (13)	Connect according to identification tag from step 8.



ELECTRICAL SYSTEM.

3-91. HEADLAMP ASSEMBLY REPLACEMENT (Continued)

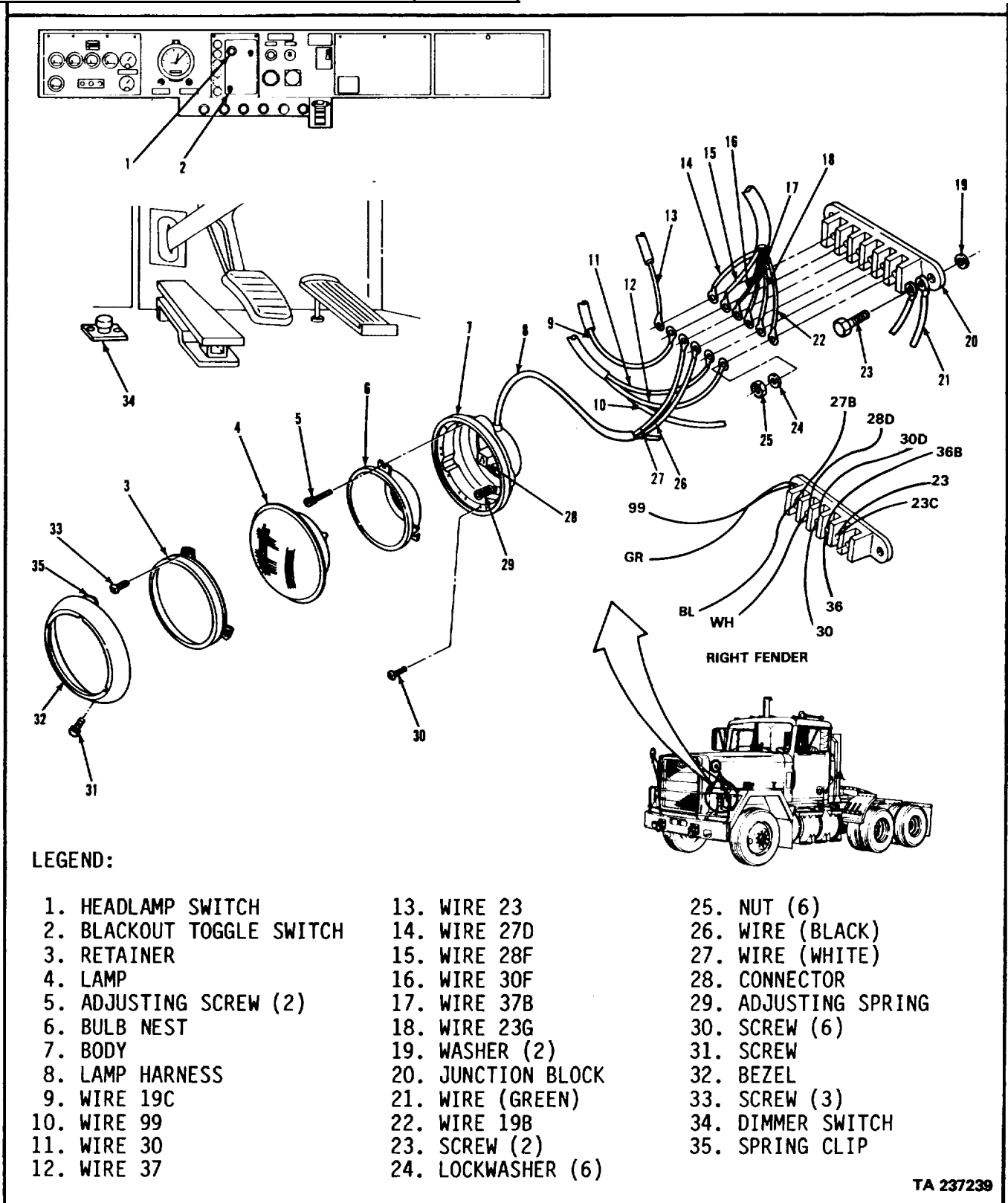

## ELECTRICAL SYSTEM.

3-91. HEADLAMP ASSEMBLY REPLACEMENT (Continued)		
LOCATION/ITEM	ACTION	REMARKS
<b><u>B. INSTALLATION (Continued). I</u></b>		
16. Six nuts (25) and six lockwashers (24).	Install and tighten on item (20).	
17. Bulb nest (6) and body (7)	Move into position and install with six items (30) Tighten six items (30) alternately and evenly	Item (7) is keyed to fit cutout in fender. Rotate item (7) until it slips into mounting cutout.
18. Lamp (4)	Connect item (28) and insert item (4) into item (6).	
19. Retainer (3)	Install with three items (33)	Note position of mounting ears on item (3) from step (3).
20. Bezel (32)	Install with item (31).	
<b><u>C. OPERATIONAL CHECK. I</u></b>		
21. Blackout toggle switch (2)	Set to normal	Refer to TM 9-2320-283-10.
22. Headlamp switch (1)	Pull on to second stop	Refer to TM 9-2320-283-10.
23. Lamp (4)	Observe that item (4) comes on.	
24. Dimmer switch (34)	Press and verify that high beam comes on. Press again and verify that low beam comes on.	
<p><b>NOTE</b> Follow-on maintenance action required: None.</p>		
3-530		

ELECTRICAL SYSTEM.

3-91. HEADLAMP ASSEMBLY REPLACEMENT (Continued).

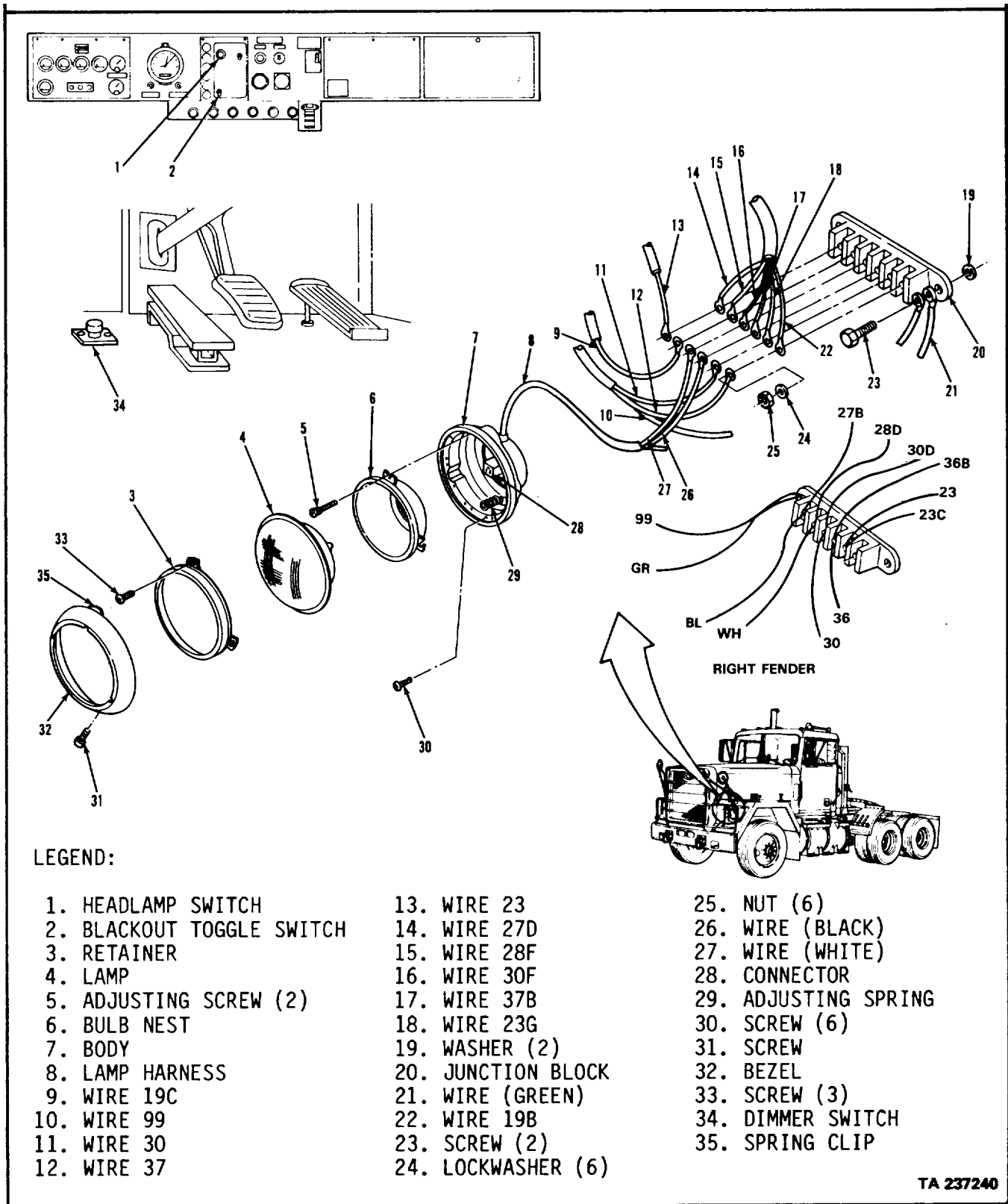

**ELECTRICAL SYSTEM.**

**3-92. TURN SIGNAL AND MARKER LAMP REPLACEMENT**

**THIS TASK COVERS**

- a. Turn Signal and Marker Lamp Bulb Removal.
- b. Turn Signal and Marker Lamp Bulb Installation.
- c. Turn Signal and Marker Lamp Assembly Removal.
- d. Turn Signal and Marker Lamp Assembly Installation.
- e. Operational Check.

**INITIAL SETUP**

<u>APPLICABLE CONFIGURATIONS</u>	<u>EQUIPMENT CONDITION</u> <u>PARAGRAPH</u>	<u>CONDITION DESCRIPTION</u>
All.	None.	None.

TEST EQUIPMENT  
None.

SPECIAL TOOLS  
None.

MATERIALS/PARTS (P/N)  
None.

PERSONNEL REQUIRED  
One (MOS-63S) .

SPECIAL ENVIRONMENTAL CONDITIONS  
None.

REFERENCES (TM)  
TM 9-2320-283-10.

GENERAL SAFETY INSTRUCTIONS  
Engine off.  
Transmission in neutral.  
Park brake set.

TROUBLESHOOTING REFERENCES  
Paragraph 2-11.

ELECTRICAL SYSTEM.

3-92. TURN SIGNAL AND MARKER LAMP REPLACEMENT (Continued)

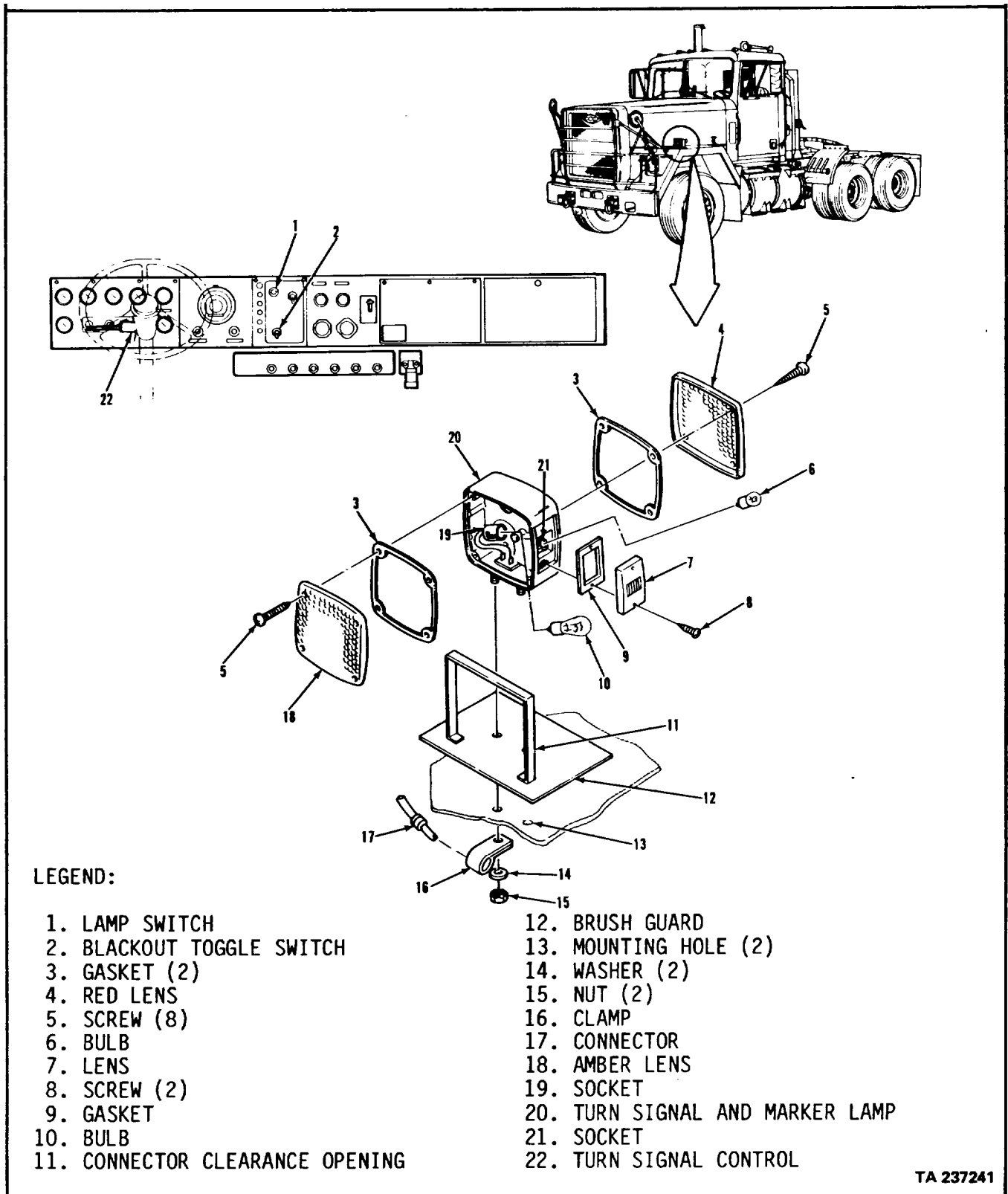

TA 237241

**ELECTRICAL SYSTEM.**

<b>3-92. TURN SIGNAL AND MARKER LAMP REPLACEMENT</b>		
<b>LOCATION/ITEM</b>	<b>ACTION</b>	<b>REMARKS</b>
<p><b>NOTE</b> Turn signal and marker lamp bulb and assembly replacement is the same for both sides.</p>		
<b><u>A. TURN SIGNAL AND MARKER LAMP BULB REMOVAL. I</u></b>		
<p><b>NOTE</b> If turn signal bulb is to be replaced, do steps 1, 2, 3, 9, and 10. If marker lamp bulb is to be replaced, do steps 4, 5, 6, 7, and 8.</p>		
1. Four screws (5)	Remove from item (18).	
2. Amber lens (18) and gasket (3).	Remove.	
3. Bulb (10)	Remove from item (19)	Push in and turn a quarter turn to the left.
4. Two screws (8)	Remove.	
5. Lens (7) and gasket (9).	Remove.	
6. Bulb (6)	Remove from item (21)	Push in and turn a quarter turn to the left.
<b><u>B. TURN SIGNAL AND MARKER LAMP BULB INSTALLATION. I</u></b>		
7. Bulb (6)	Install in item (21)	Push in and turn a quarter turn to the right.
8. Lens (7) and gasket (9)	Install and secure with two items (8)	Do not overtighten two items (8).

ELECTRICAL SYSTEM.

3-92. TURN SIGNAL AND MARKER LAMP REPLACEMENT (Continued).

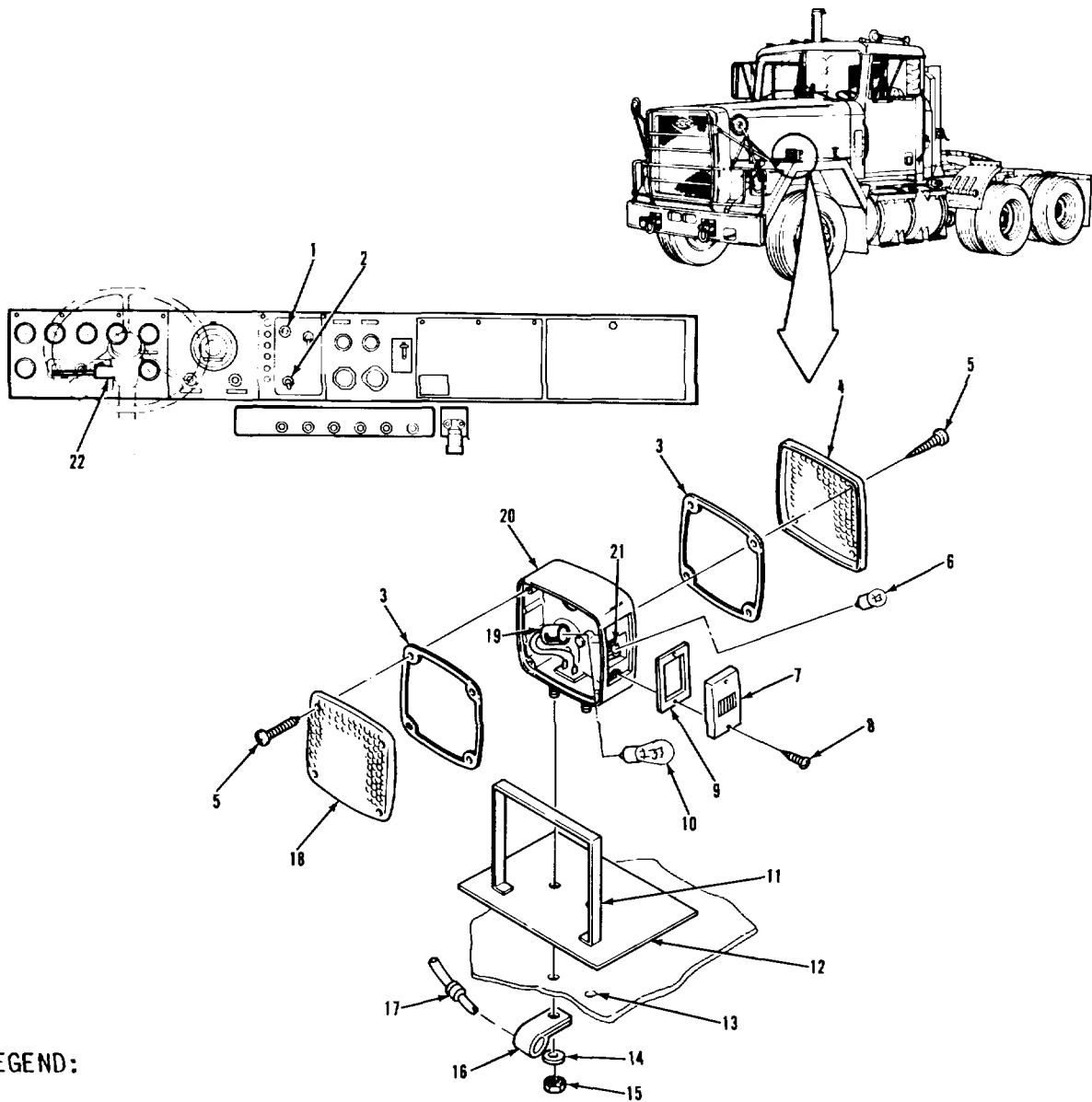

LEGEND:

- |                                 |                                 |
|---------------------------------|---------------------------------|
| 1. LAMP SWITCH                  | 12. BRUSH GUARD                 |
| 2. BLACKOUT TOGGLE SWITCH       | 13. MOUNTING HOLE (2)           |
| 3. GASKET (2)                   | 14. WASHER (2)                  |
| 4. RED LENS                     | 15. NUT (2)                     |
| 5. SCREW (8)                    | 16. CLAMP                       |
| 6. BULB                         | 17. CONNECTOR                   |
| 7. LENS                         | 18. AMBER LENS                  |
| 8. SCREW (2)                    | 19. SOCKET                      |
| 9. GASKET                       | 20. TURN SIGNAL AND MARKER LAMP |
| 10. BULB                        | 21. SOCKET                      |
| 11. CONNECTOR CLEARANCE OPENING | 22. TURN SIGNAL CONTROL         |

TA 237242

## ELECTRICAL SYSTEM.

<b>3-92. TURN SIGNAL LAMP REPLACEMENT (Continued)</b>		
<b>LOCATION/ITEM</b>	<b>ACTION</b>	<b>REMARKS</b>
<b><u>B. TURN SIGNAL AND MARKER LAMP BULB INSTALLATION (Continued). I</u></b>		
9. Bulb (10)	Install in item (19)	Push in and turn a quarter turn to the right.
10. Red lens (4) and gasket (3)	Install and secure with four items (5)	Do not over tighten four items (5).
<b><u>C. TURN SIGNAL AND MARKER LAMP ASSEMBLY REMOVAL. I</u></b>		
11. Eight screws (5)	Remove.	
12. Amber lens (18), red lens (4), and two gaskets (3).	Remove.	
13. Two screws (8), lens (7), and gasket (9).	Remove.	
14. Connector (17)	Disconnect from base of item (20)	Disconnect from under fender.
15. Two nuts (15), two washers (14), and clamp (16).	Remove.	
16. Turn signal and marker lamp (20) and brush guard (12).	Remove.	
<b><u>D. TURN SIGNAL AND MARKER LAMP ASSEMBLY INSTALLATION. I</u></b>		
17. Brush guard (12)	Place on top of fender. Align item (11) and two items (13) with matching holes.	
18. Turn signal and marker lamp (20)	Install through item (12) with opening in side for item (7) facing out.	



ELECTRICAL SYSTEM.

3-92. TURN SIGNAL AND MARKER LAMP REPLACEMENT (Continued)

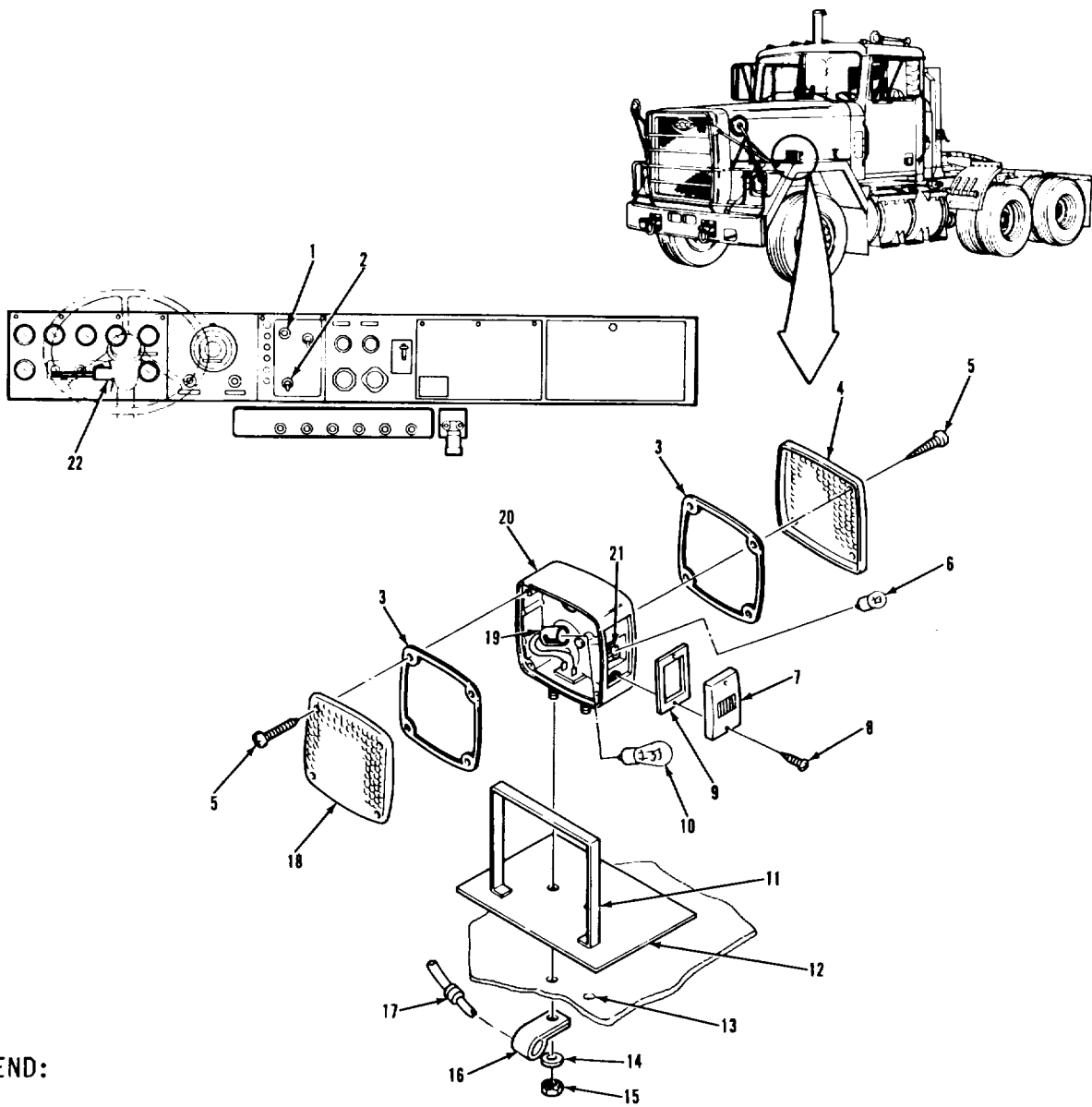

LEGEND:

- |                                 |                                 |
|---------------------------------|---------------------------------|
| 1. LAMP SWITCH                  | 12. BRUSH GUARD                 |
| 2. BLACKOUT TOGGLE SWITCH       | 13. MOUNTING HOLE (2)           |
| 3. GASKET (2)                   | 14. WASHER (2)                  |
| 4. RED LENS                     | 15. NUT (2)                     |
| 5. SCREW (8)                    | 16. CLAMP                       |
| 6. BULB                         | 17. CONNECTOR                   |
| 7. LENS                         | 18. AMBER LENS                  |
| 8. SCREW (2)                    | 19. SOCKET                      |
| 9. GASKET                       | 20. TURN SIGNAL AND MARKER LAMP |
| 10. BULB                        | 21. SOCKET                      |
| 11. CONNECTOR CLEARANCE OPENING | 22. TURN SIGNAL CONTROL         |

TA 237243

**ELECTRICAL SYSTEM.**

<b>3-92. TURN SIGNAL AND MARKER LAMP REPLACEMENT (Continued)</b>		
<b>LOCATION/ITEM</b>	<b>ACTION</b>	<b>REMARKS</b>
<b><u>D. TURN SIGNAL AND MARKER LAMP ASSEMBLY INSTALLATION (Continued). I</u></b>		
19. Clamp (16)	Install on one stud on item (20).	
20. Two nuts (15) and two washers (14).	Install and tighten.	
21. Connector (17)	Install.	
22. Lens (7) and gasket (9)	Install and secure with two items (8)	Do not over tighten two items (8).
23. Amber lens (18), red lens (4), and two gaskets (3).	Install and secure with eight items (5)	Do not over tighten eight items (5).
<b><u>E. OPERATIONAL CHECK. I</u></b>		
24. Blackout toggle switch (2)	Set to normal	Refer to TM 9-2320-283-10.
25. Lamp switch (1)	<ul style="list-style-type: none"> <li>a. Pull out to first stop.</li> <li>b. Verify that items (6) and (10) come on.</li> </ul>	
26. Turn signal control (22)	<ul style="list-style-type: none"> <li>a. Push lever down. Verify that left item (10) flashes.</li> <li>b. Push lever up. Verify that right item (10) flashes.</li> </ul>	
<p><b>NOTE</b> Follow-on maintenance action required: None.</p>		
<p><b>3-538</b></p>		

ELECTRICAL SYSTEM.

3-92. TURN SIGNAL AND MARKER LAMP REPLACEMENT (Continued).

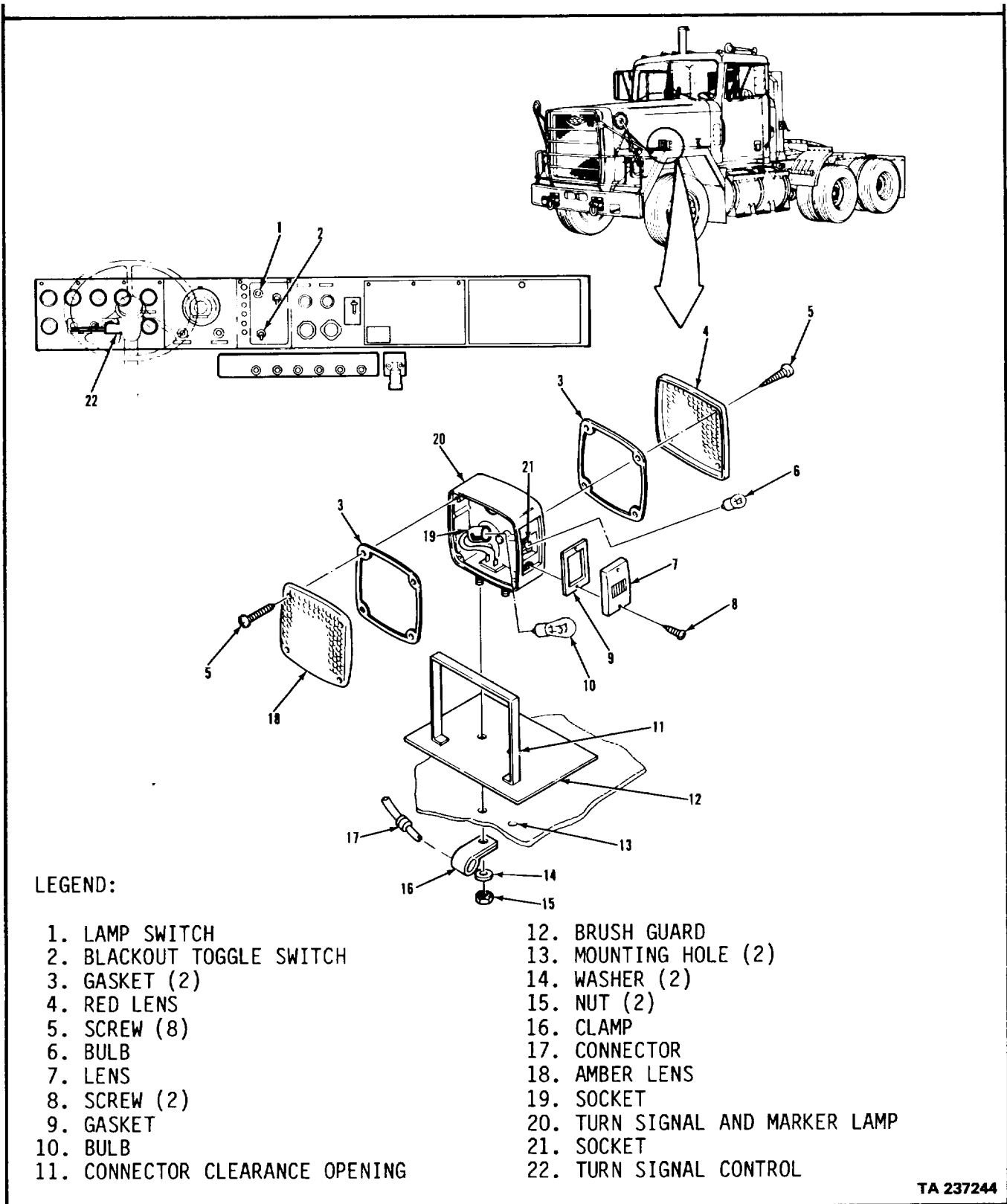

TA 237244

ELECTRICAL SYSTEM.

**3-93. CAB CLEARANCE LAMP ASSEMBLY REPLACEMENT**

**THIS TASK COVERS**

- |  |  |
|--|--|
| a. Cab Clearance Lamp Removal          | d. Cab Clearance Lamp Assembly Installation. |
| b. Cab Clearance Lamp Installation     | e. Operational Check.                        |
| c. Cab Clearance Lamp Assembly Removal |  |

**INITIAL SETUP**

<b><u>APPLICABLE CONFIGURATIONS</u></b>	<b><u>EQUIPMENT CONDITION</u></b> <b><u>PARAGRAPH</u></b>	<b><u>CONDITION DESCRIPTION</u></b>
All	TM 9-2320-283-20	Headlamp switch off.

**TEST EQUIPMENT**

None.

**SPECIAL TOOLS**

None.

**MATERIALS/PARTS (P/N)**

Putty, linseed oil  
Item 21, Appendix C.  
Sealer, nonhardening  
Item 25, Appendix C.

**PERSONNEL REQUIRED**

One (MOS-63S)

**SPECIAL ENVIRONMENTAL CONDITIONS**

None.

**REFERENCES (TM)**

TM 9-2320-283-10  
Transmission in neutral.  
Park brake set.

**GENERAL SAFETY INSTRUCTIONS**

Engine off.

**TROUBLESHOOTING REFERENCES**

Paragraph 2-11.

ELECTRICAL SYSTEM.

3-93. CAB CLEARANCE LAMP ASSEMBLY REPLACEMENT (Continued).

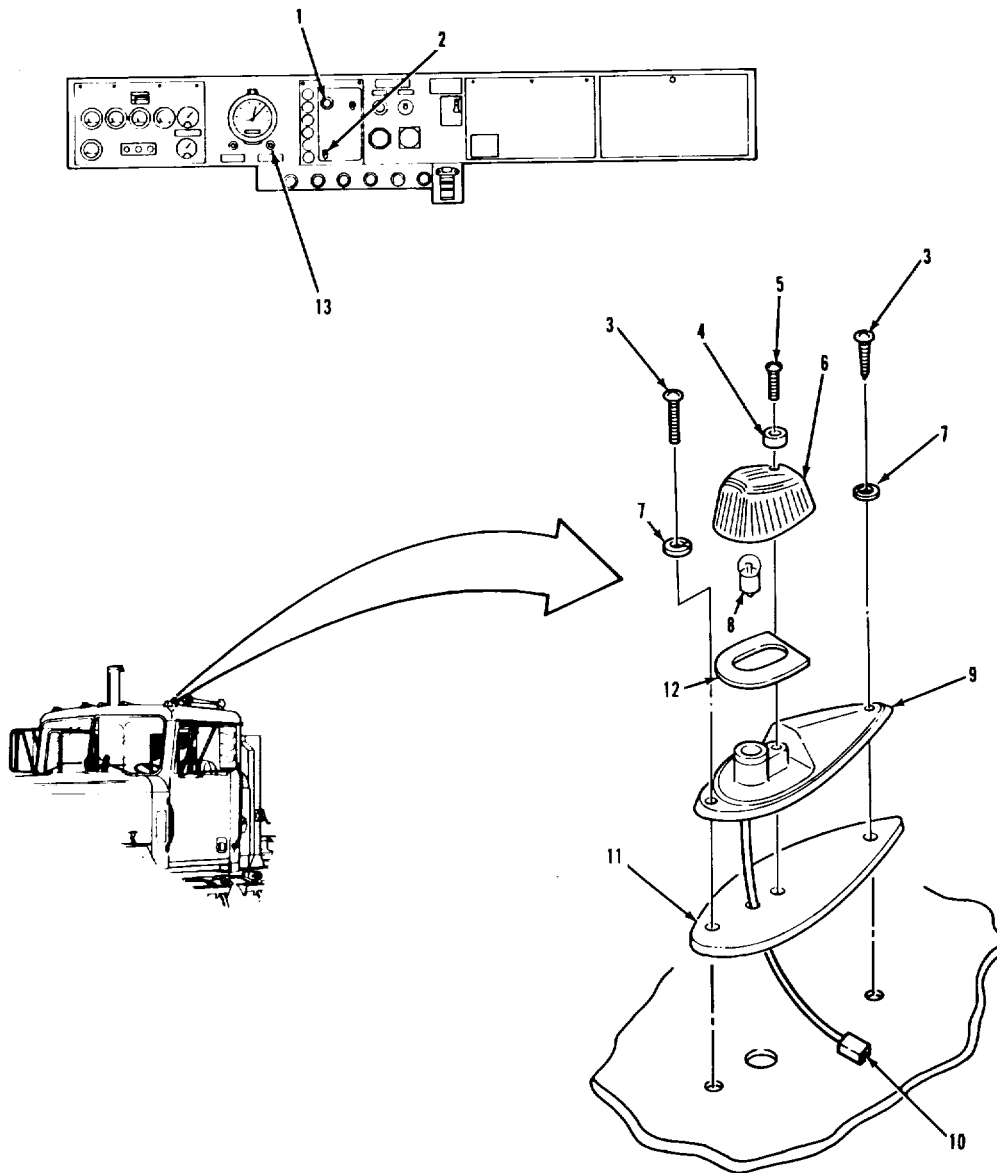

LEGEND:

- |                           |   |
|---------------------------|---|
| 1. HEADLAMP SWITCH        | 8. LAMP                                 |
| 2. BLACKOUT TOGGLE SWITCH | 9. BASE                                 |
| 3. SCREW (2)              | 10. CONNECTOR                           |
| 4. SEAL                   | 11. GASKET                              |
| 5. SCREW                  | 12. GASKET                              |
| 6. AMBER LENS             | 13. PUSHBUTTON CLEARANCE<br>LAMP SWITCH |
| 7. LOCKWASHER (2)         |   |

TA 237245

**ELECTRICAL SYSTEM.**

<b>3-93. CAB CLEARANCE LAMP ASSEMBLY REPLACEMENT (Continued)</b>		
<b>LOCATION/ITEM</b>	<b>ACTION</b>	<b>REMARKS</b>
<p><b>NOTE</b>                      Replacement procedures for all cab clearance lamps and cab clearance lamp assemblies are the same. Legend item quantities are for one cab clearance and marker lamp assembly.</p>		
<b><u>A. CAB CLEARANCE LAMP REMOVAL. I</u></b>		
1. Screw (5) and seal (4).	Remove.	
2. Amber lens (6) and gasket (12)	Remove	Discard item (12) if cracked or torn.
3. Lamp (8)	Remove.	
<b><u>B. CAB CLEARANCE LAMP INSTALLATION. I</u></b>		
4. Lamp (8)	Install.	
5. Amber lens (6) and gasket (12).	Replace.	
6. Screw (5) and seal (4).	Install and tighten.	
<b><u>C. CAB CLEARANCE LAMP ASSEMBLY REMOVAL. I</u></b>		
7. Two screws (3) and two lockwashers (7).	Remove.	
8. Base (9) and gasket (11)	Remove	Discard item (11) if cracked or torn.
<p><b>3-542</b></p>		

ELECTRICAL SYSTEM.

3-93. CAB CLEARANCE LAMP ASSEMBLY REPLACEMENT (Continued)

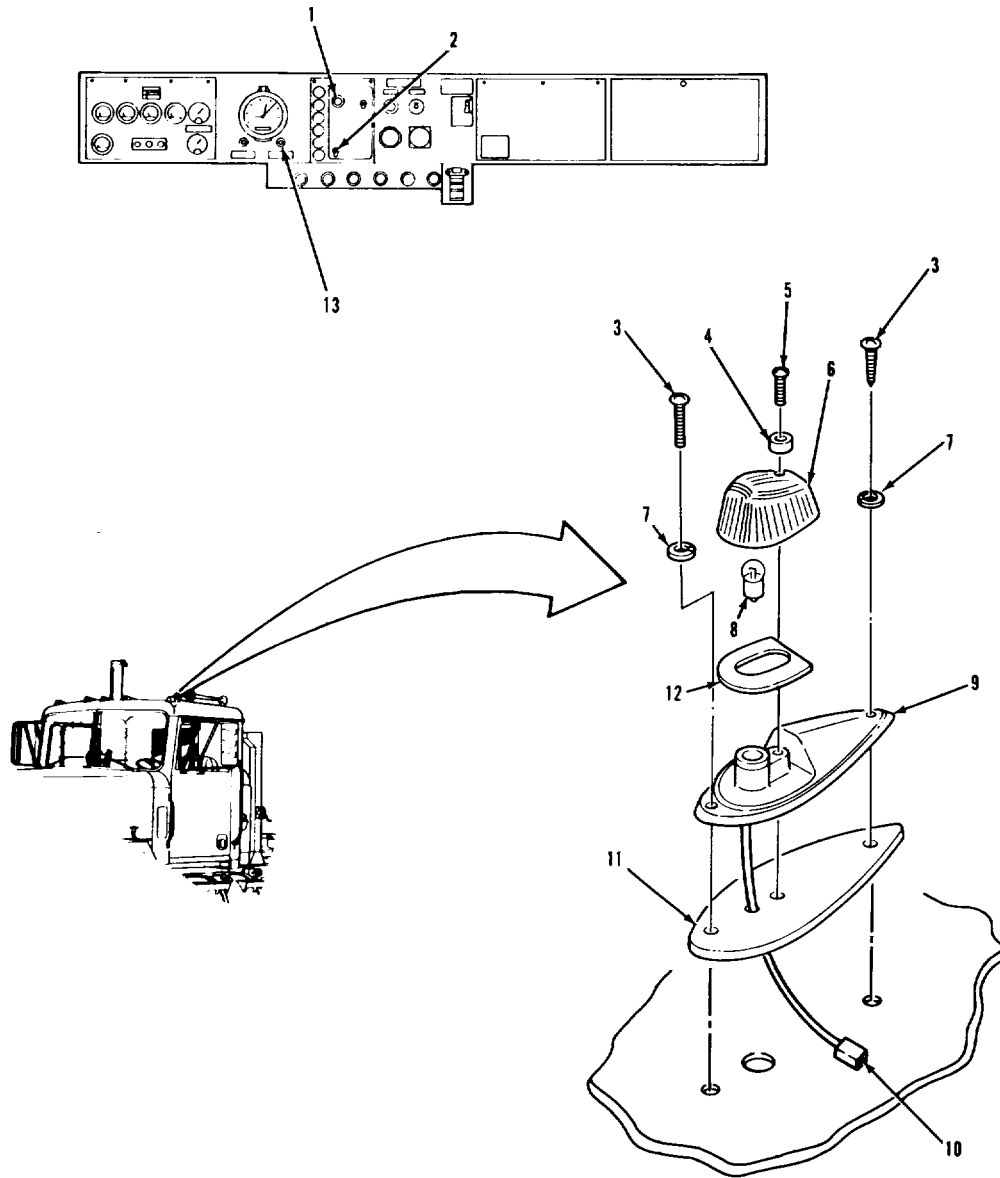

LEGEND:

- 1. HEADLAMP SWITCH
- 2. BLACKOUT TOGGLE SWITCH
- 3. SCREW (2)
- 4. SEAL
- 5. SCREW
- 6. AMBER LENS
- 7. LOCKWASHER (2)

- 8. LAMP
- 9. BASE
- 10. CONNECTOR
- 11. GASKET
- 12. GASKET
- 13. PUSHBUTTON CLEARANCE LAMP SWITCH

TA 237246

**ELECTRICAL SYSTEM.**

<b>3-93. CAB CLEARANCE LAMP ASSEMBLY REPLACEMENT (Continued).</b>		
<b>LOCATION/ITEM</b>	<b>ACTION</b>	<b>REMARKS</b>
<b><u>c. CAB CLEARANCE LAMP ASSEMBLY REMVAL (Continued)</u></b>		
9. Connector (10)	Disconnect	Pull wire lead through cab roof about 6" to expose item (10). Make sure that other end of wire lead does not slip back through hole in cab roof
<b><u>D. CAB CLEARANCE LAMP ASSEMBLY INSTALLATION. I</u></b>		
10. Connector (10)	Connect.	
11. Base (9) and gasket (11)	Align mounting holes and install	Use small amount of putty to seal holes in roof.
12. Two screws (3) and two lock-washer (7).	Install and tighten.	
<b><u>E. OPERATIONAL CHECK. I</u></b>		
13. Blackout toggle switch (2)	Set to normal	Refer to TM 9-2320-283-10.
14. Headlamp switch (1).	a. Pull out to first stop. b. Verify that all items (8) come on.	
15. Push button clearance lamp switch (13).	Press and verify that all items (8) go off.	
<p><b>NOTE</b></p> <ul style="list-style-type: none"> <li>• After performing operational check, apply nonhardening sealer over tops of two base mounting screws to prevent water entry.</li> <li>• Follow-on maintenance action required: None.</li> </ul>		
<p><b>3-544</b></p>		



ELECTRICAL SYSTEM.

**3-93. CAB CLEARANCE LAMP ASSEMBLY REPLACEMENT (Continued).**

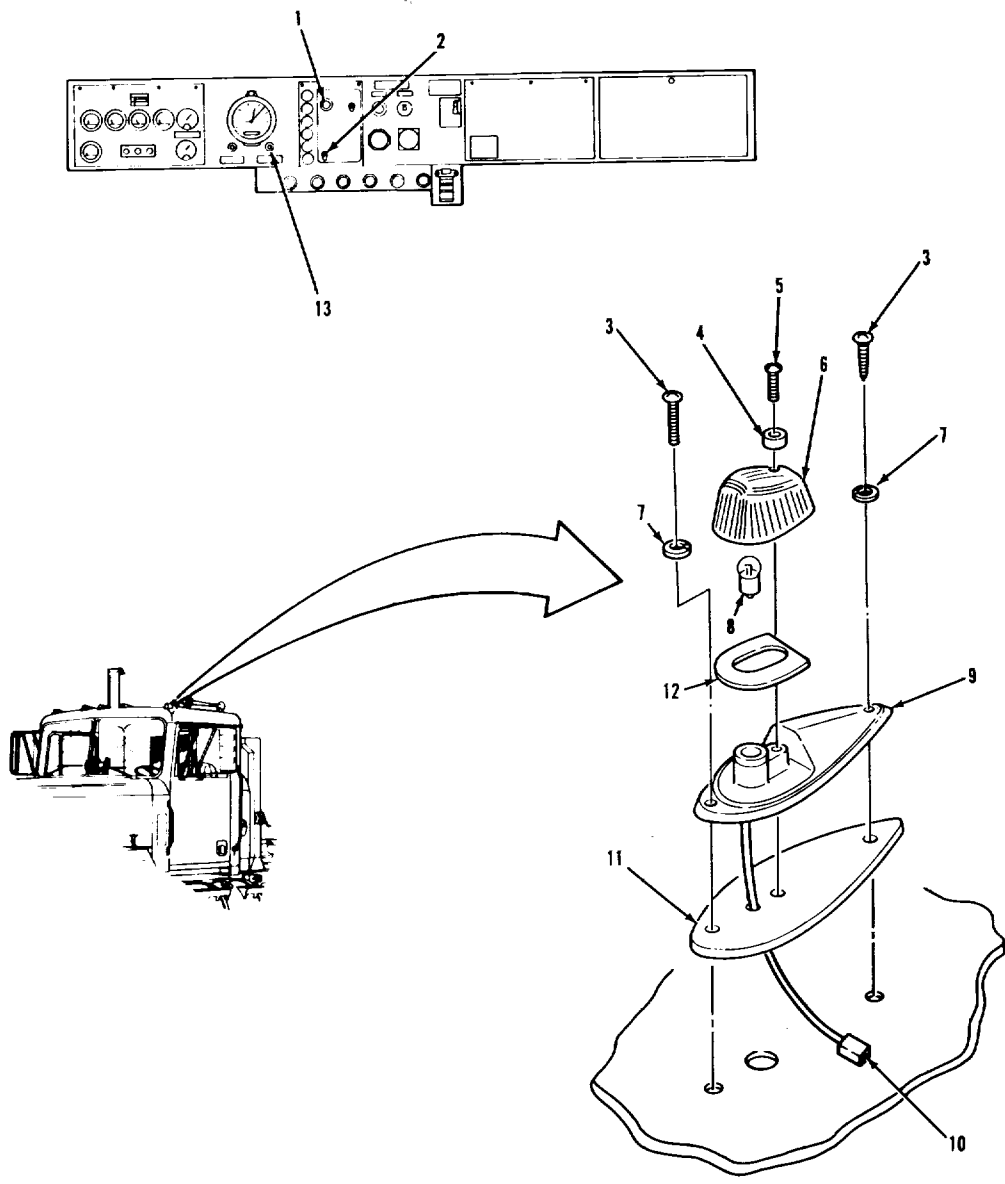

LEGEND:

- |                           |   |
|---------------------------|---|
| 1. HEADLAMP SWITCH        | 8. LAMP                                 |
| 2. BLACKOUT TOGGLE SWITCH | 9. BASE                                 |
| 3. SCREW (2)              | 10. CONNECTOR                           |
| 4. SEAL                   | 11. GASKET                              |
| 5. SCREW                  | 12. GASKET                              |
| 6. AMBER LENS             | 13. PUSHBUTTON CLEARANCE<br>LAMP SWITCH |
| 7. LOCKWASHER (2)         |   |

TA 237247

**ELECTRICAL SYSTEM.**

**3-94. BLACKOUT MARKER LAMP ASSEMBLY REPLACEMENT.**

THIS TASK COVERS

- a. Blackout Marker Lamp Removal.
- b. Blackout Marker Lamp Installation.
- c. Blackout Marker Lamp Assembly Removal.
- d. Blackout Marker Lamp Assembly Disassembly.
- e. Blackout Marker Lamp Assembly Reassemble.
- f. Blackout Marker Lamp Assembly Installation.
- g. Blackout Marker Lamp Assembly Operational Check.

INITIAL SETUP

<u>APPLICABLE CONFIGURATIONS</u>	<u>EQUIPMENT CONDITION</u> <u>PARAGRAPH</u>	<u>CONDITION DESCRIPTION</u>
All	TM 9-2320-283-10	Headlamp switch off.
	TM 9-2320-283-10	Blackout toggle switch
<u>TEST EQUIPMENT</u> None.	set to normal.	
	3-91	Headlamp assembly removed

SPECIAL TOOLS

None.

MATERIALS/PARTS (P/N)

None.

PERSONNEL REQUIRED

One (MOS-63S)

SPECIAL ENVIRONMENTAL CONDITIONS

None.

REFERENCES (TM)

TM 9-2320-283-10

GENERAL SAFETY INSTRUCTIONS

Engine off.  
Transmission in neutral.  
Park brake set.

TROUBLESHOOTING REFERENCES

Paragraph 2-11.

ELECTRICAL SYSTEM.

3-94. BLACKOUT MARKER LAMP ASSEMBLY REPLACEMENT (Continued)

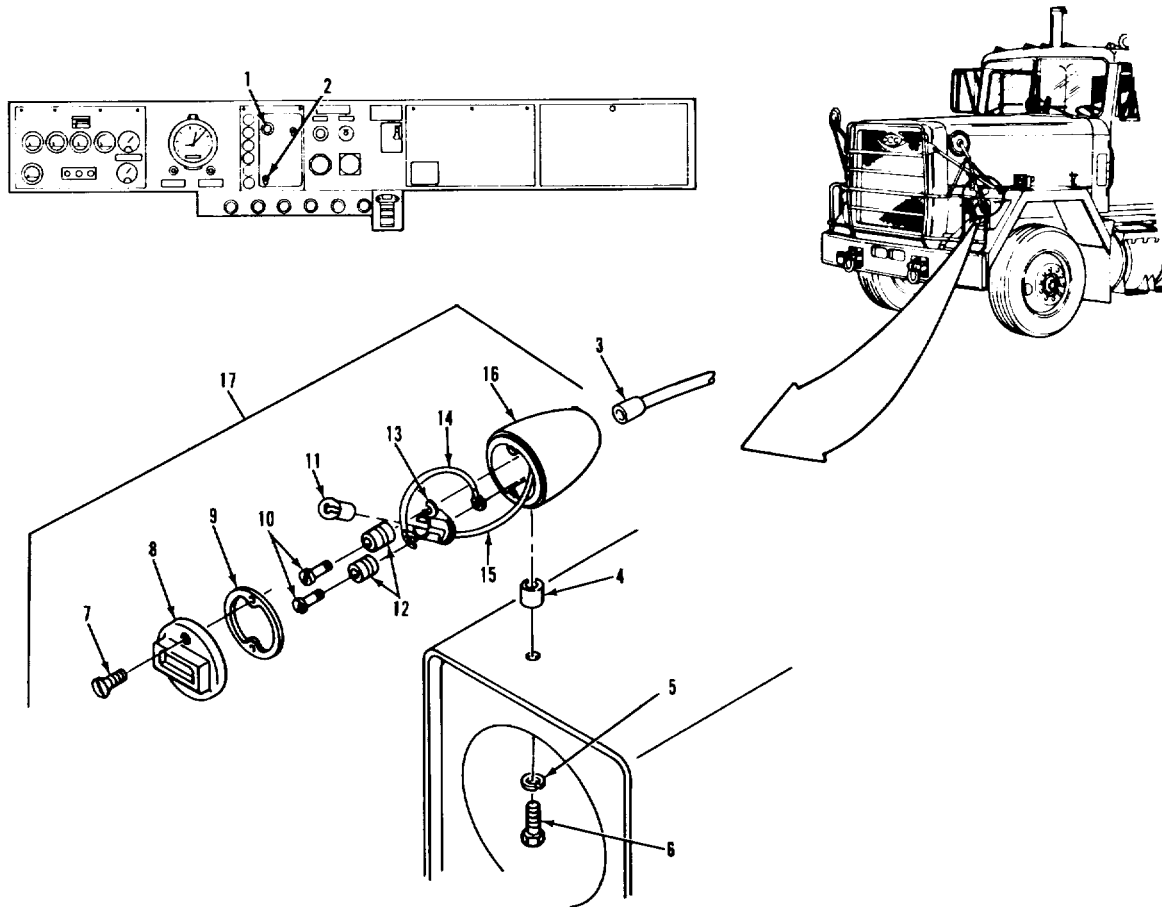

LEGEND:

- |                               |                                   |
|-------------------------------|-----------------------------------|
| 1. HEADLAMP SWITCH            | 10. SHOULDER SCREW (2)            |
| 2. BLACKOUT TOGGLE SWITCH     | 11. LAMP                          |
| 3. BLACKOUT MARKER LAMP CABLE | 12. GROMMET (2)                   |
| 4. SPACER                     | 13. HOLDER                        |
| 5. LOCKWASHER                 | 14. JUMPER                        |
| 6. SCREW                      | 15. CONNECTOR                     |
| 7. SCREW (2)                  | 16. HOUSING                       |
| 8. DOOR ASSEMBLY              | 17. BLACKOUT MARKER LAMP ASSEMBLY |
| 9. GASKET                     |                                   |

TA 237248

3-94. BLACKOUT MARKER LAMP ASSEMBLY REPLACEMENT (Continued).		
LOCATION/ITEM	ACTION	REMARKS
<b>NOTE</b> Replacement procedures for left and right fender blackout. marker lamp assemblies are the same.		
<b>A. BLACKOUT MARKER LAMP REMOVAL. I</b>		
1. Two screws (7)	Remove.	
2. Door assembly (8) and gasket (9)	Remove	Discard item (9) if cracked or torn.
3. Lamp (11)	Remove	Push in and turn a quarter turn to the left.
<b>B. BLACKOUT MARKER LAMP INSTALLATION. I</b>		
4. Lamp (11)	Install in item (13)	Push in and turn a quarter turn to the right.
5. Gasket (9)	Install in item (8).	
6. Door assembly (8) and gasket (9)	Align and install	Keyway at bottom of item (8).
7. Two screws (7)	Install and tighten.	
<b>C. BLACKOUT MARKER LAMP ASSEMBLY REMOVAL. I</b>		
8. Blackout marker lamp cable (3)	Disconnect from back of item (14)	Pull straight out. Grasp item (3) where it enters item (14).
9. Screw (6) and lock washer (5) 3-91).	Loosen and remove	Remove headlamp assembly. (Refer to paragraph
10. Blackout marker lamp assembly (16) and spacer (4).	Remove.	

ELECTRICAL SYSTEM.

**3-94. BLACKOUT MARKER LAMP ASSEMBLY REPLACEMENT (Continued).**

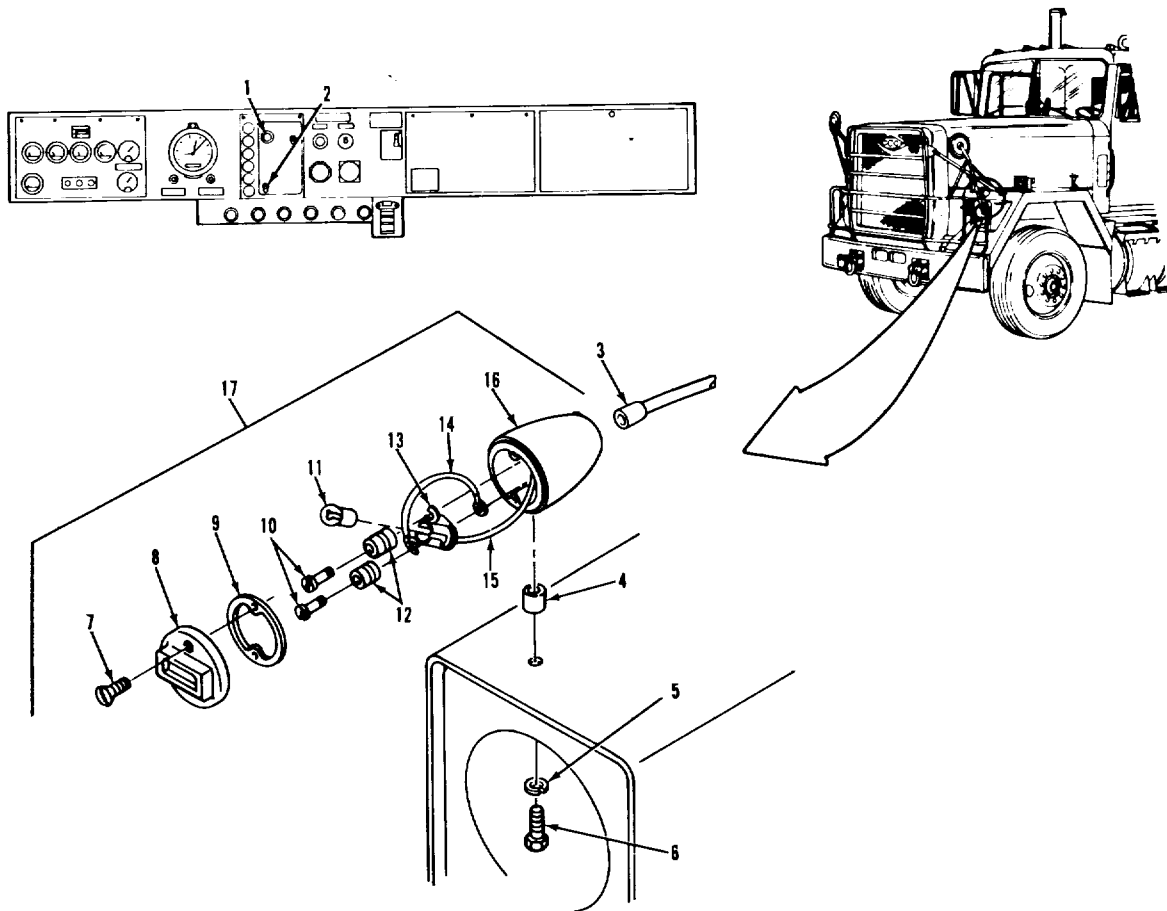

LEGEND:

- |                               |                                   |
|-------------------------------|-----------------------------------|
| 1. HEADLAMP SWITCH            | 10. SHOULDER SCREW (2)            |
| 2. BLACKOUT TOGGLE SWITCH     | 11. LAMP                          |
| 3. BLACKOUT MARKER LAMP CABLE | 12. GROMMET (2)                   |
| 4. SPACER                     | 13. HOLDER                        |
| 5. LOCKWASHER                 | 14. JUMPER                        |
| 6. SCREW                      | 15. CONNECTOR                     |
| 7. SCREW (2)                  | 16. HOUSING                       |
| 8. DOOR ASSEMBLY              | 17. BLACKOUT MARKER LAMP ASSEMBLY |
| 9. GASKET                     |                                   |

TA 237249

3-94. BLACKOUT MARKER LAMP ASSEMBLY REPLACEMENT (Continued).		
LOCATION/ITEM	ACTION	REMARKS
<b><u>D. BLACKOUT MARKER LAMP ASSEMBLY DISASSEMBLY. I</u></b>		
11. Two screws (7)	Remove.	
12. Door assembly (8).	Remove.	
13. Gasket (9)	Remove	Discard if cracked or torn.
14. Lamp (11)	Remove	Push in and turn a quarter turn to the left.
15. Two shoulder screws (10).	Remove.	
16. Holder (13) and jumper (14)	Disconnect item (15) and then remove item (13) and item (14).	
17. Two grommets (12).	Remove from item (13)	Discard items (12) if cracked or torn.
<b><u>E. BLACKOUT MARKER LAMP ASSEMBLY REASSEMBLY. I</u></b>		
18. Two grommets (12)	Install on item (13).	
19. Two shoulder screws (10)	Install through two items (12).	
20. Jumper (14)	Install on back of one item (12).	
21. Holder (13) and jumper (14)	Move into position, connect item (15), and secure with two items (10).	Make sure item (14) stays on item (10).
22. Lamp (11)	Install in item (13)	Push in and turn a quarter turn to the right.

ELECTRICAL SYSTEM.

**3-94. BLACKOUT MARKER LAMP ASSEMBLY REPLACEMENT (Continued)**

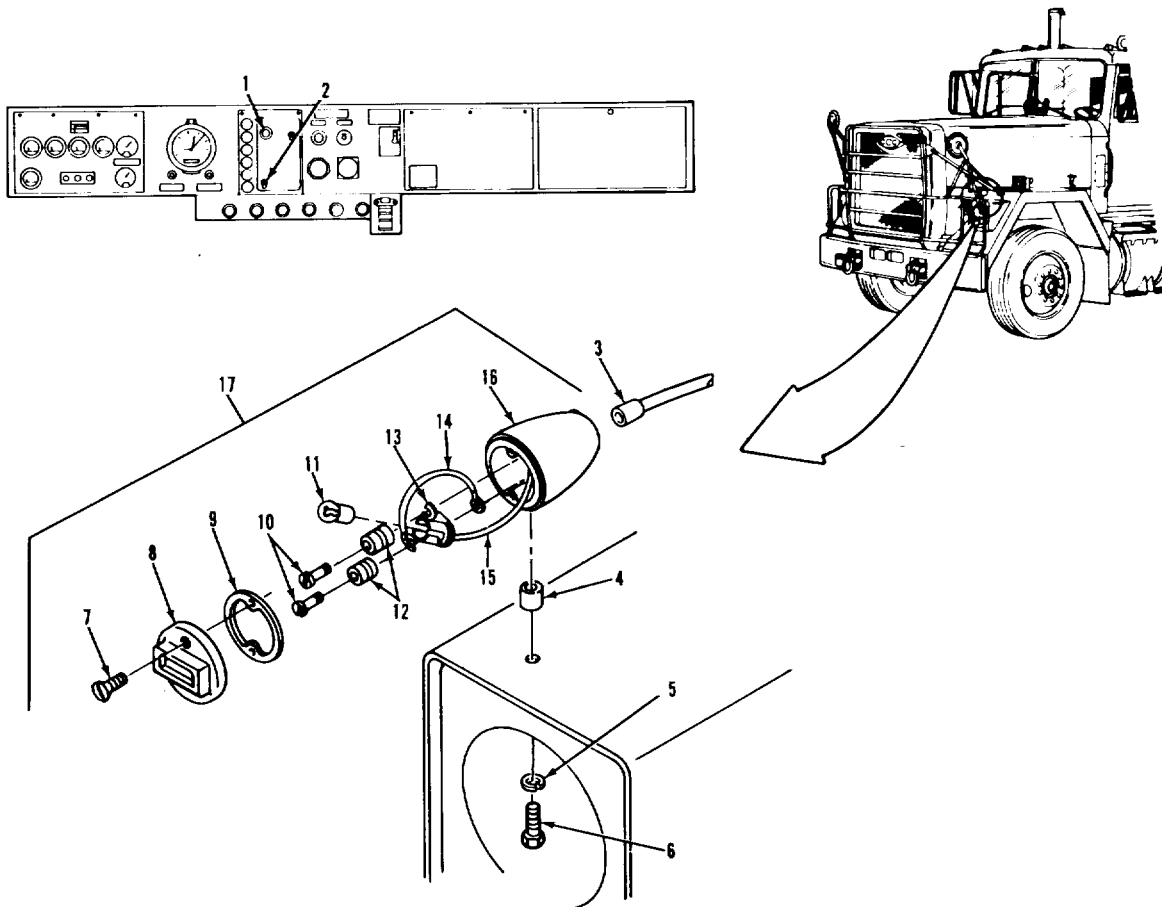

LEGEND:

- |                               |                                   |
|-------------------------------|-----------------------------------|
| 1. HEADLAMP SWITCH            | 10. SHOULDER SCREW (2)            |
| 2. BLACKOUT TOGGLE SWITCH     | 11. LAMP                          |
| 3. BLACKOUT MARKER LAMP CABLE | 12. GROMMET (2)                   |
| 4. SPACER                     | 13. HOLDER                        |
| 5. LOCKWASHER                 | 14. JUMPER                        |
| 6. SCREW                      | 15. CONNECTOR                     |
| 7. SCREW (2)                  | 16. HOUSING                       |
| 8. DOOR ASSEMBLY              | 17. BLACKOUT MARKER LAMP ASSEMBLY |
| 9. GASKET                     |                                   |

TA 237250

**ELECTRICAL SYSTEM.**

<b>3-94. BLACKOUT MARKER LAMP ASSEMBLY REPLACEMENT (Continued).</b>		
<b>LOCATION/ITEM</b>	<b>ACTION</b>	<b>REMARKS</b>
<b><u>E. BLACKOUT MARKER LAMP ASSEMBLY REASSEMBLY (Continued). I</u></b>		
23. Gasket (9)	Install in item (8).	
24. Door assembly (8) and gasket (9)	Align and install (8).	Key way at bottom of item
25. Two screws (7)	Install and tighten.	
<b><u>F. BLACKOUT MARKER LAMP ASSEMBLY INSTALLATION. I</u></b>		
26. Spacer (4)	Align with mounting hole on fender.	
27. Blackout marker lamp assembly (17)	Install on spacer (4). Secure with item (5) and item (6), and tighten.	
28. Blackout marker lamp cable (3).	Connect to back of item (6).	
<b><u>G. BLACKOUT MARKER LAMP ASSEMBLY OPERATIONAL CHECK. I</u></b>		
29. Operation switch (2)	Set to blackout	Refer to TM 9-2320-283-10.
30. Headlamp switch (1)	a. Pull out to first position.  b. Verify that blackout marker lamp comes on.	
<b>NOTE</b>		
Follow-on maintenance action required:		
Replace headlamp assembly (para 3-91).		
<b>3-552</b>		



ELECTRICAL SYSTEM.

3-94. BLACKOUT MARKER LAMP ASSEMBLY REPLACEMENT (Continued).

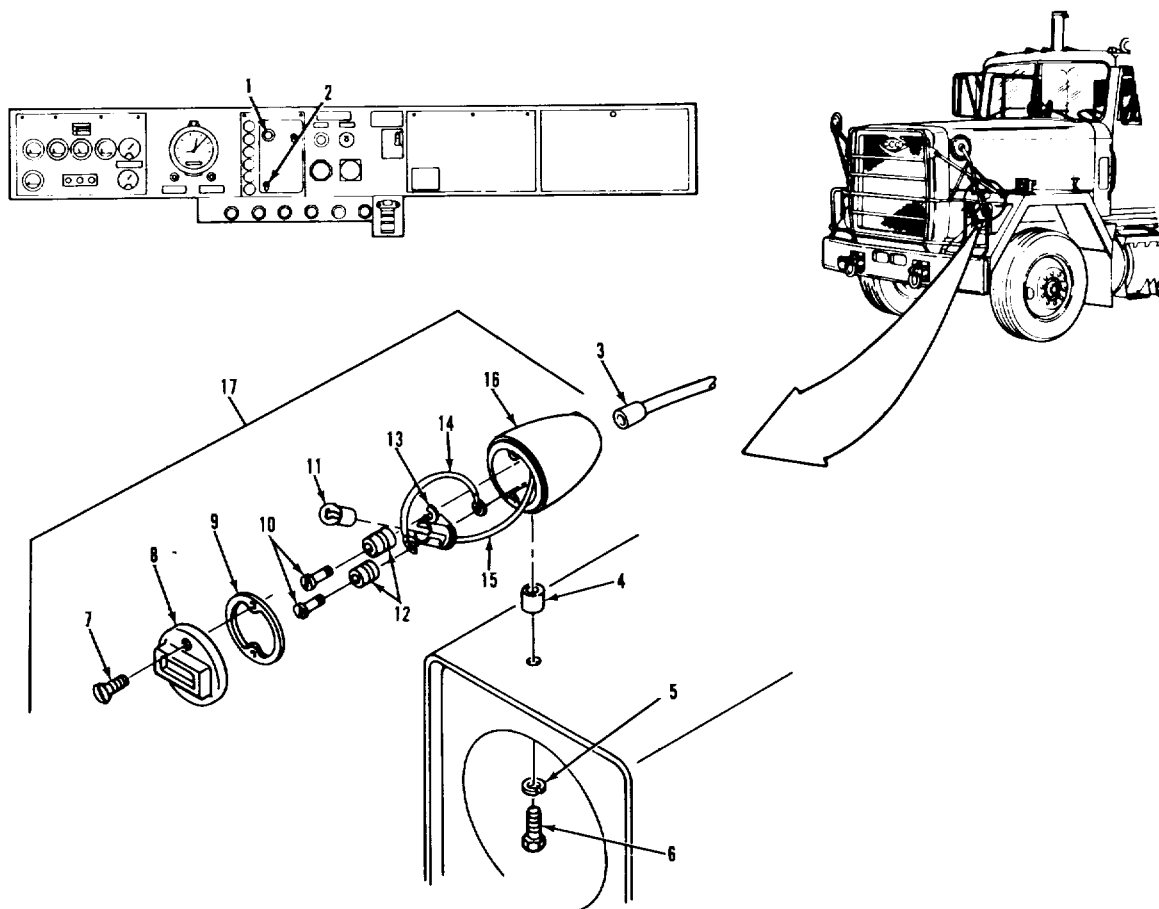

LEGEND:

- |                               |                                   |
|-------------------------------|-----------------------------------|
| 1. HEADLAMP SWITCH            | 10. SHOULDER SCREW (2)            |
| 2. BLACKOUT TOGGLE SWITCH     | 11. LAMP                          |
| 3. BLACKOUT MARKER LAMP CABLE | 12. GROMMET (2)                   |
| 4. SPACER                     | 13. HOLDER                        |
| 5. LOCKWASHER                 | 14. JUMPER                        |
| 6. SCREW                      | 15. CONNECTOR                     |
| 7. SCREW (2)                  | 16. HOUSING                       |
| 8. DOOR ASSEMBLY              | 17. BLACKOUT MARKER LAMP ASSEMBLY |
| 9. GASKET                     |                                   |

**ELECTRICAL SYSTEM.**

**3-95. BLACKOUT HEADLAMP ASSEMBLY REPLACEMENT.**

THIS TASK COVERS

- a. Blackout Headlamp Removal.
- b. Blackout Headlamp Installation.
- c. Blackout Headlamp Assembly Removal.
- d. Blackout Headlamp Assembly Disassembly.
- e. Blackout Headlamp Assembly Reassembly.
- f. Blackout Headlamp Assembly Installation.
- g. Blackout Headlamp Assembly Operational Check.

INITIAL SETUP

<p><u>APPLICABLE CONFIGURATIONS</u> All.</p>	<p><u>EQUIPMENT CONDITION PARAGRAPH</u> TM 9-2320-283-10.</p>	<p><u>CONDITION DESCRIPTION</u> Headlamp switch off.</p>
<p><u>TEST EQUIPMENT</u> None.</p>	<p>TM 9-2320-283-10.</p>	<p>Blackout toggle switch set to normal.</p>
<p><u>SPECIAL TOOLS</u> None.</p>		
<p><u>MATERIALS/PARTS (P/N)</u> None.</p>		
<p><u>PERSONNEL REQUIRED</u> One (MOS-63S).</p>	<p><u>SPECIAL ENVIRONMENTAL CONDITIONS</u> None.</p>	
<p><u>REFERENCES (TM)</u> TM 9-2320-283-10.</p>	<p><u>GENERAL SAFETY INSTRUCTIONS</u> Engine off. Transmission in neutral. Park brake set.</p>	
<p><u>TROUBLESHOOTING REFERENCES</u> Paragraph 2-11.</p>		

ELECTRICAL SYSTEM.

3-95. BLACKOUT HEADLAMP ASSEMBLY REPLACEMENT (Continued).

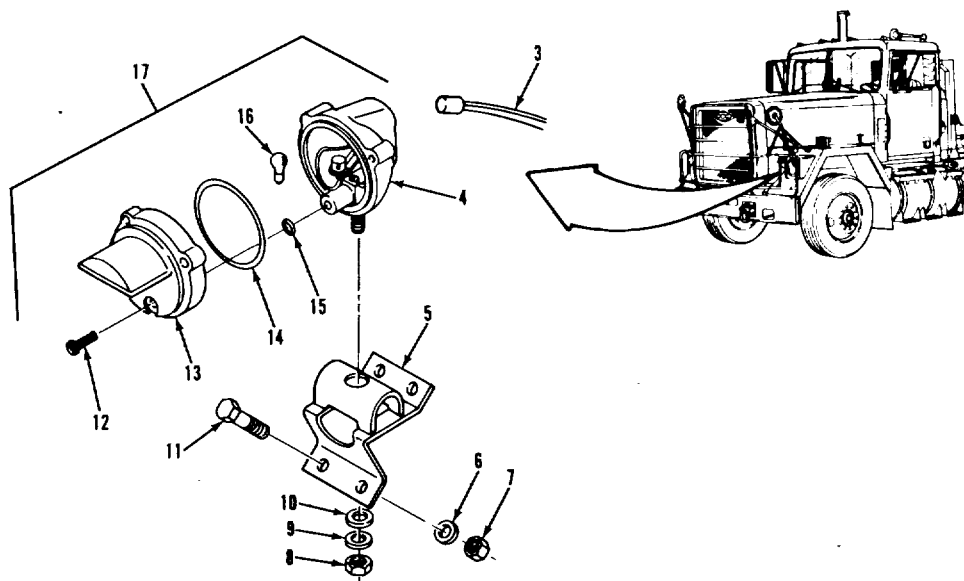
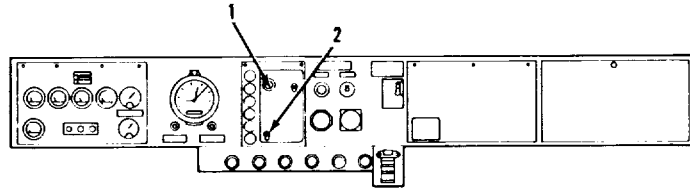

LEGEND:

- |                            |                                |
|----------------------------|--------------------------------|
| 1. HEADLAMP SWITCH         | 10. WASHER                     |
| 2. BLACKOUT TOGGLE SWITCH  | 11. SCREW (4)                  |
| 3. BLACKOUT HEADLAMP CABLE | 12. SCREW (3)                  |
| 4. BODY                    | 13. COVER                      |
| 5. SUPPORT                 | 14. GASKET                     |
| 6. WASHER (4)              | 15. GASKET                     |
| 7. NUT (4)                 | 16. LAMP                       |
| 8. NUT                     | 17. BLACKOUT HEADLAMP ASSEMBLY |
| 9. WASHER                  |                                |

## ELECTRICAL SYSTEM.

3.95. BLACKOUT HEADLAMP ASSEMBLY REPLACEMENT (Continued)		
LOCATION/ITEM	ACTION	REMARKS
A. <u>BLACKOUT HEADLAMP REMOVAL.</u>		
1. Three screws (12).	Remove.	
2. Cover (13).	Remove.	
3. Lamp (16).	Remove.	Push in and turn a quarter turn to the left.
B. <u>BLACKOUT HEADLAMP INSTALLATION.</u>		
4. Lamp (16).	Install.	
5. Cover (13).	Align and install.	
6. Three screws (12).	Install and tighten.	
C. <u>BLACKOUT HEADLAMP ASSEMBLY REMOVAL.</u>		
7. Blackout headlamp cable (3).	Disconnect from back of item (4).	Grasp item (3) where it enters item (4) and pull straight out on boot.
8. Nut (8), washer (10), and washer (9).	Remove.	
9. Blackout headlamp assembly (17).	Remove.	
10. Four nuts (7), four washers (6), and four screws (11).	Loosen and remove.	
11. Support (5).Remove.		

ELECTRICAL SYSTEM.

3-95. BLACKOUT HEADLAMP ASSEMBLY REPLACEMENT (Continued).

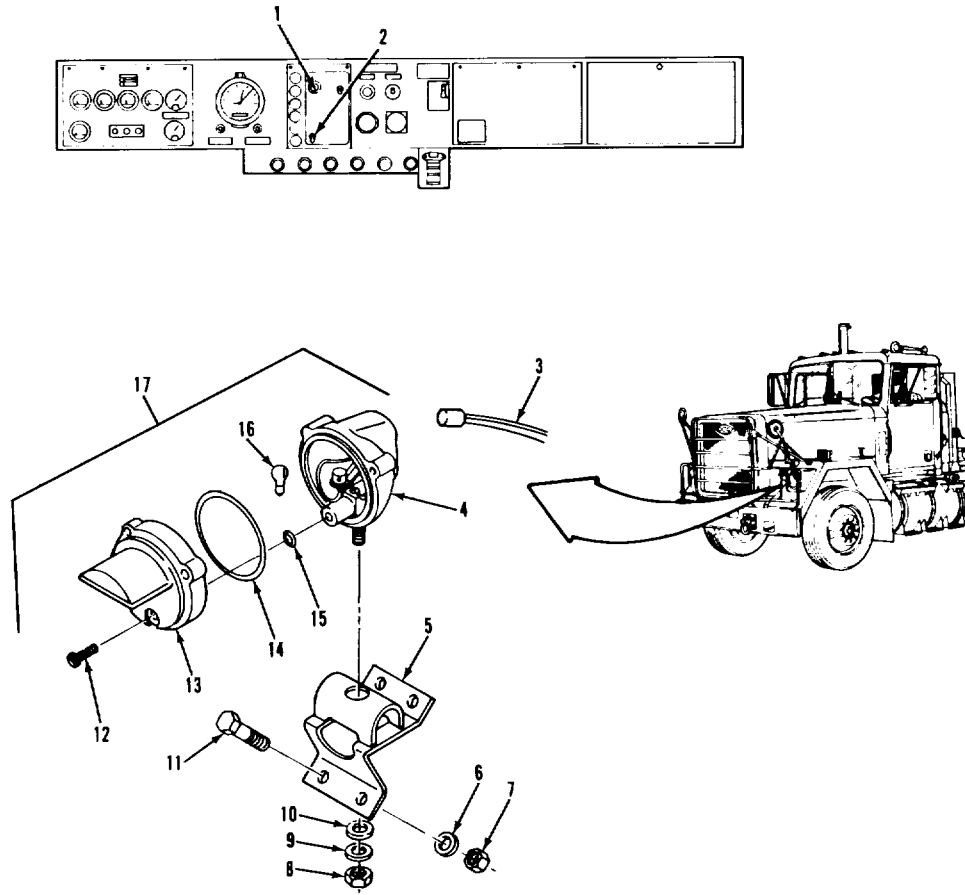

LEGEND:

- |                            |                                |
|----------------------------|--------------------------------|
| 1. HEADLAMP SWITCH         | 10. WASHER                     |
| 2. BLACKOUT TOGGLE SWITCH  | 11. SCREW (4)                  |
| 3. BLACKOUT HEADLAMP CABLE | 12. SCREW (3)                  |
| 4. BODY                    | 13. COVER                      |
| 5. SUPPORT                 | 14. GASKET                     |
| 6. WASHER (4)              | 15. GASKET                     |
| 7. NUT (4)                 | 16. LAMP                       |
| 8. NUT                     | 17. BLACKOUT HEADLAMP ASSEMBLY |
| 9. WASHER                  |                                |

## ELECTRICAL SYSTEM.

3-95. BLACKOUT HEADLAMP ASSEMBLY REPLACEMENT (Continued)		
LOCATION/ITEM	ACTION	REMARKS
<b>D. <u>BLACKOUT HEADLAMP ASSEMBLY DISASSEMBLY.</u></b>		
12. Three screws (12).	Remove.	
13. Cover (13).	Remove.	
14. Gasket (14) and gasket (15).	Remove from item (13).	Use small blade screwdriver. Discard item (14) or item (15) if cracked or distorted.
15. Lamp (16).	Remove.	Push in and turn a quarter turn to the left.
<b>E. <u>BLACKOUT HEADLAMP ASSEMBLY REASSEMBLY.</u></b>		
16. Lamp (16).	Install.	Push in and turn a quarter turn to the right.
17. Gasket (14) and gasket (15).	Install in item (13).	
18. Three screws (12).	Install and tighten.	
<b>F. <u>BLACKOUT HEADLAMP ASSEMBLY INSTALLATION.</u></b>		
19. Support (5).	Align with mounting holes in fender.	
20. Four nuts (7), four washers (6), and four screws (11).	Install through item (5) into fender, and tighten.	
21. Blackout headlamp assembly (17).	Install onto item (5).	

ELECTRICAL SYSTEM.

3-95. BLACKOUT HEADLAMP ASSEMBLY REPLACEMENT (Continued).

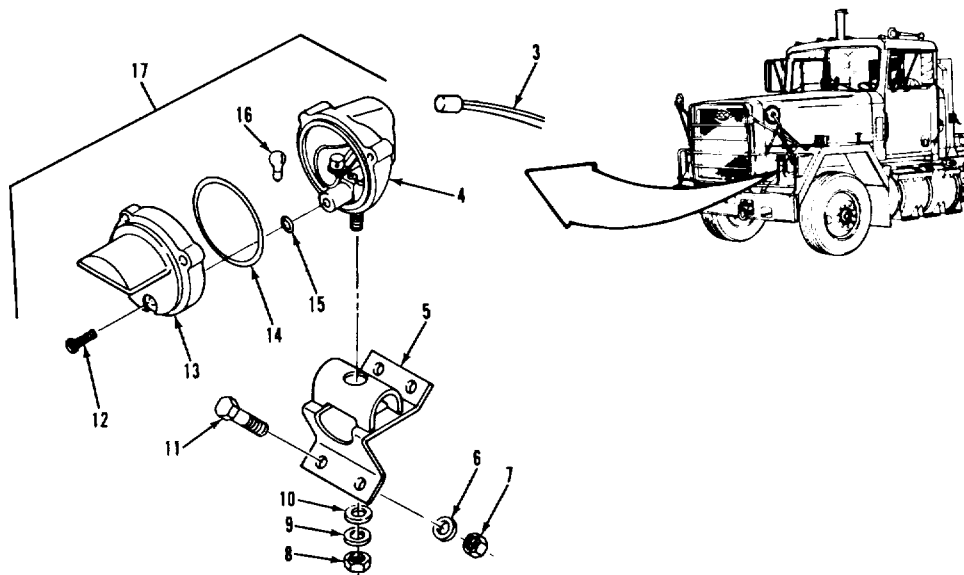
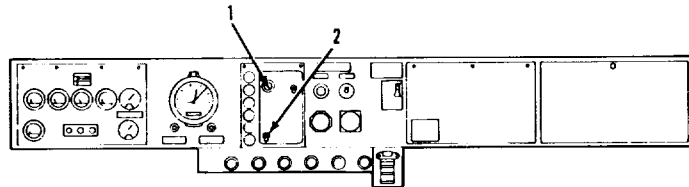

LEGEND:

- |                            |                                |
|----------------------------|--------------------------------|
| 1. HEADLAMP SWITCH         | 10. WASHER                     |
| 2. BLACKOUT TOGGLE SWITCH  | 11. SCREW (4)                  |
| 3. BLACKOUT HEADLAMP CABLE | 12. SCREW (3)                  |
| 4. BODY                    | 13. COVER                      |
| 5. SUPPORT                 | 14. GASKET                     |
| 6. WASHER (4)              | 15. GASKET                     |
| 7. NUT (4)                 | 16. LAMP                       |
| 8. NUT                     | 17. BLACKOUT HEADLAMP ASSEMBLY |
| 9. WASHER                  |                                |

**ELECTRICAL SYSTEM.**

<b>3.95. BLACKOUT HEADLAMP ASSEMBLY REPLACEMENT (Continued).</b>		
<b>LOCATION/ITEM</b>	<b>ACTION</b>	<b>REMARKS</b>
<b>F. <u>BLACKOUT HEADLAMP ASSEMBLY INSTALLATION (Continued).</u></b>		
22. Nut (8), washer (9), and washer (10).	Install and tighten.	
23. Blackout headlamp cable (3).	Connect to back of item (4).	
<b>G. <u>BLACKOUT MARKER LAMP ASSEMBLY OPERATIONAL CHECK.</u></b>		
24. Blackout toggle switch (2).	Set to blackout.	Refer to TM 9-2320-283-10.
25. Headlamp switch (1).	<ul style="list-style-type: none"> <li>a. Pull out to second position.</li> <li>b. Verify that blackout headlamp comes on.</li> </ul>	
<p>NOTE</p> <p>Follow-on maintenance action required:</p> <p>None.</p>		
<b>3-560</b>		



ELECTRICAL SYSTEM.

3-95. BLACKOUT HEADLAMP ASSEMBLY REPLACEMENT (Continued).

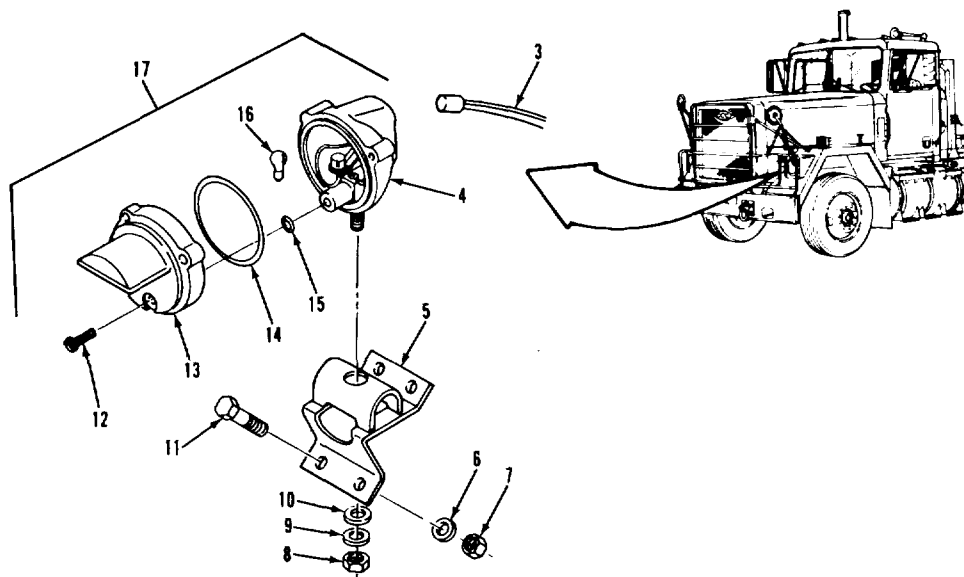
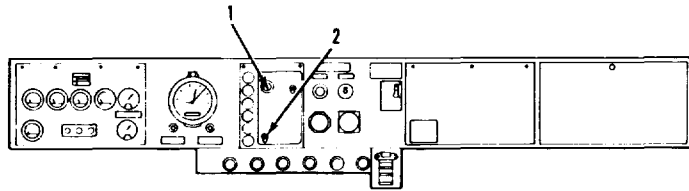

LEGEND:

- |                            |                                |
|----------------------------|--------------------------------|
| 1. HEADLAMP SWITCH         | 10. WASHER                     |
| 2. BLACKOUT TOGGLE SWITCH  | 11. SCREW (4)                  |
| 3. BLACKOUT HEADLAMP CABLE | 12. SCREW (3)                  |
| 4. BODY                    | 13. COVER                      |
| 5. SUPPORT                 | 14. GASKET                     |
| 6. WASHER (4)              | 15. GASKET                     |
| 7. NUT (4)                 | 16. LAMP                       |
| 8. NUT                     | 17. BLACKOUT HEADLAMP ASSEMBLY |
| 9. WASHER                  |                                |

**ELECTRICAL SYSTEM.**

**3-96. STOPLAMP-TAILLAMP ASSEMBLY REPLACEMENT.**

**THIS TASK COVERS**

- a. Stoplamp-Taillamp-Backup Lamp Removal.
- b. Stoplamp-Taillamp-Backup Lamp Installation.
- c. Stoplamp-Taillamp Assembly Removal.
- d. Stoplamp-Taillamp Assembly Disassembly.
- e. Stoplamp-Taillamp Assembly Reassembly
- f. Stoplamp-Taillamp Assembly Installation.
- g. Stoplamp-Taillamp Operational Check.

**INITIAL SETUP**

<p><u>APPLICABLE CONFIGURATIONS</u> All.</p>	<p><u>EQUIPMENT CONDITION PARAGRAPH</u> TM 9-2320-283-10.</p>	<p><u>CONDITION DESCRIPTION</u> Headlamp switch off.</p>
<p><u>TEST EQUIPMENT</u> None.</p>	<p>TM 9-2320-283-10.</p>	<p>Blackout toggle switch set to normal</p>
<p><u>SPECIAL TOOLS</u> None.</p>		
<p><u>MATERIALS/PARTS (P/N)</u> Grease, automotive and artillery Item 7, Appendix C. Solvent, dry cleaning, SD-2 Item 29, Appendix C.</p>		
<p><u>PERSONNEL REQUIRED</u> Two (MOS-63S).</p>	<p><u>SPECIAL ENVIRONMENTAL CONDITIONS</u> None.</p>	
<p><u>REFERENCES (TM)</u> TM 9-2320-283-10.</p>	<p><u>GENERAL SAFETY INSTRUCTIONS</u> Engine off. Transmission in neutral. Park brake set.</p>	
<p><u>TROUBLESHOOTING REFERENCES</u> Paragraph 2-11.</p>		

ELECTRICAL SYSTEM.

3-96. STOPLAMP-TAILLAMP ASSEMBLY REPLACEMENT (Continued).

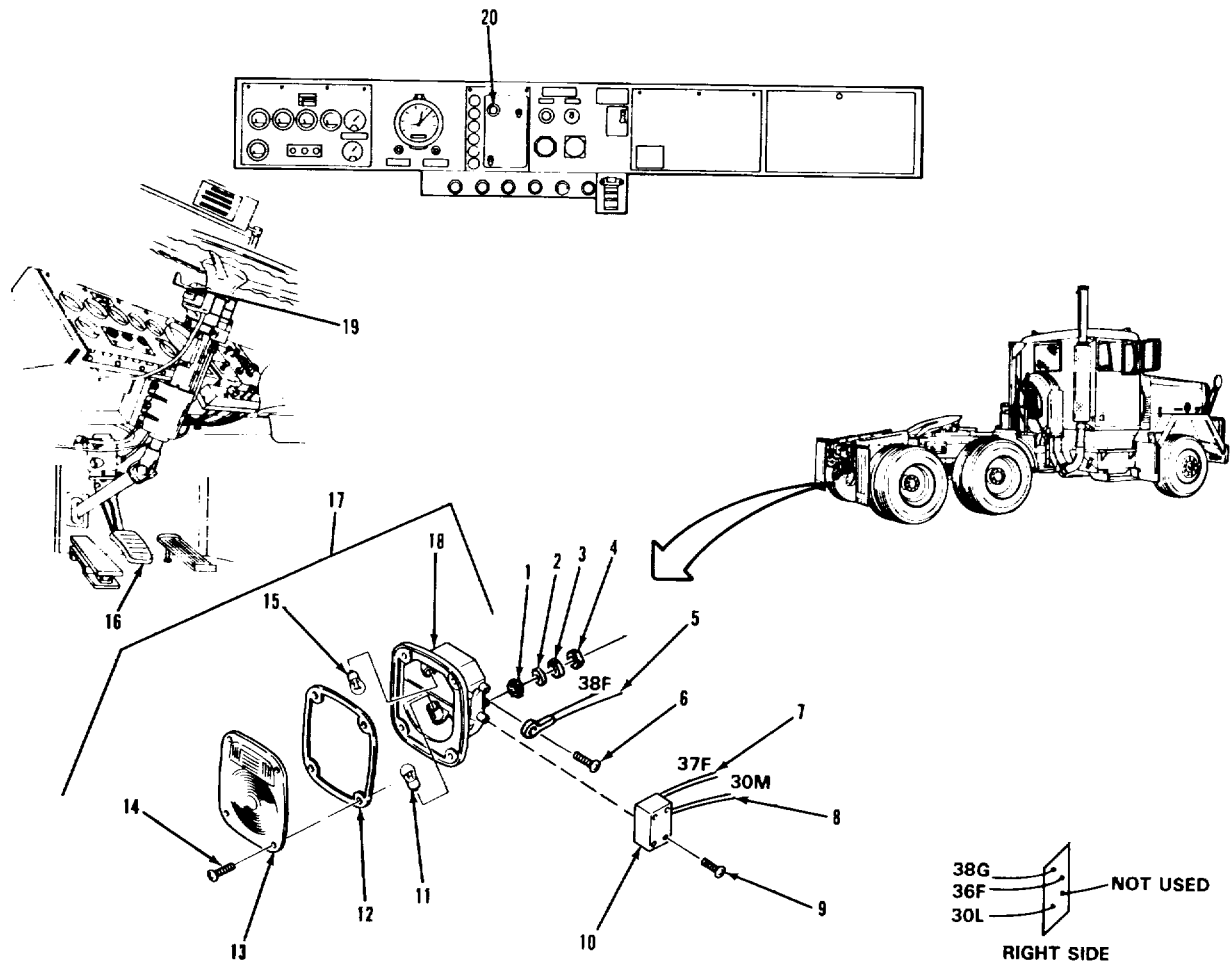

LEGEND:

- |                           |                                |
|---------------------------|--------------------------------|
| 1. LOCKWASHER             | 11. LAMP                       |
| 2. WASHER (2)             | 12. GASKET                     |
| 3. LOCKWASHER (2)         | 13. LENS                       |
| 4. NUT (2)                | 14. SCREW (4)                  |
| 5. WIRE (38F) (RIGHT 38G) | 15. LAMP                       |
| 6. SCREW (3)              | 16. BRAKE PEDAL                |
| 7. WIRE (37F) (RIGHT 36F) | 17. STOPLAMP-TAILLAMP ASSEMBLY |
| 8. WIRE (30M) (RIGHT 30L) | 18. HOUSING                    |
| 9. SCREW (4)              | 19. TURN SIGNAL CONTROL        |
| 10. COVER                 | 20. HEADLAMP SWITCH            |

TA 237256

ELECTRICAL SYSTEM.

3.96. STOPLAMP-TAILLAMP ASSEMBLY REPALCMENT (Continued)		
LOCATION/ITEM	ACTION	REMARKS
<b>NOTE</b>		
Stoplamp-taillamp-backup lamp replacement procedures are the same for both sides. covers replace-ment of the left-side stoplamp-taillamp-backup lamp.		This procedure
<b>A. <u>STOPLAMP-TAILLAMP-BACKUP LAMP REMOVAL.</u></b>		
1. Four screws (14).	Remove.	
2. Lens (13) and gasket (12).	Remove.	Discard item (12) if cracked or torn.
3. Lamp (15).	Remove.	Backup lamp. Push in and turn a quarter turn to the left.
4. Lamp (11).	Remove.	Stoplamp-taillamp-turn signal lamp. Push in and turn a quarter turn to the left.
<b>B. <u>STOPLAMP-TAILLAMP-BACKUP LAMP INSTALLATION.</u></b>		
5. Lamp (11).	Install.	Push in and turn a quarter turn to the right
6. Lamp (15).	Install.	Push in and turn a quarter turn to the right
7. Lens (13) and gasket (12).	Align and install.	Window for backup lamp on top.
8. Four screws (14).	Install and tighten.	
<b>3-564</b>		

ELECTRICAL SYSTEM.

3-96. STOPLAMP-TAILLAMP ASSEMBLY REPLACEMENT (Continued).

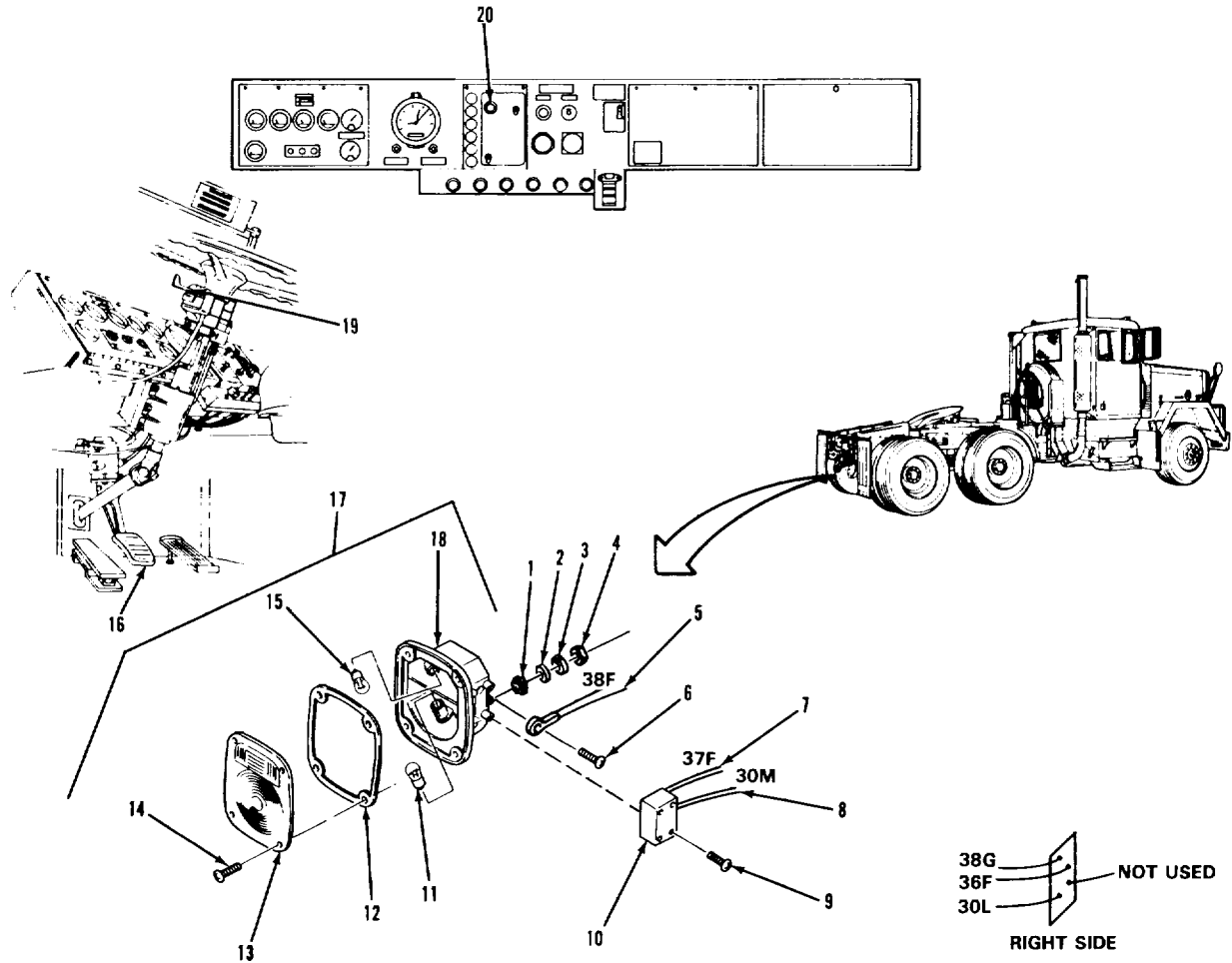

LEGEND:

- |                           |                                |
|---------------------------|--------------------------------|
| 1. LOCKWASHER             | 11. LAMP                       |
| 2. WASHER (2)             | 12. GASKET                     |
| 3. LOCKWASHER (2)         | 13. LENS                       |
| 4. NUT (2)                | 14. SCREW (4)                  |
| 5. WIRE (38F) (RIGHT 38G) | 15. LAMP                       |
| 6. SCREW (3)              | 16. BRAKE PEDAL                |
| 7. WIRE (37F) (RIGHT 36F) | 17. STOPLAMP-TAILLAMP ASSEMBLY |
| 8. WIRE (30M) (RIGHT 30L) | 18. HOUSING                    |
| 9. SCREW (4)              | 19. TURN SIGNAL CONTROL        |
| 10. COVER                 | 20. HEADLAMP SWITCH            |

## ELECTRICAL SYSTEM.

3-96. STOPLAMP-TAILLAMP ASSEMBLY REPALCEMENT (Continued)		
LOCATION/ITEM	ACTION	REMARKS
<b>C. <u>STOPLAMP-TAILLAMP ASSEMBLY REMOVAL.</u></b>		
9. Two nuts (4), two lockwashers (3), two washers (2), and one lockwasher (1).	Remove.	
10. Stoplamp-taillamp assembly (17).	Remove.	
11. Four screws (9).	Remove.	
12. Cover (10).	Remove.	
<b>NOTE</b>		
<b>Remove grease from wire connections with cleaning solvent before doing next step.</b>		
13. Three screws (6), wire (5), wire (7), and wire (8).	Remove.	Tag items (5), (7), and (8) for identification.
<b>D. <u>STOPLAMP-TAILLAMP ASSEMBLY DISASSEMBLY.</u></b>		
14. Four screws (14).	Remove.	
15. Lens (13) and gasket (12).	Remove.	Discard item (12) if cracked or torn.
16. Lamp (15) and lamp (11). left.	Remove.	Push in and turn a quarter turn to the
<b>3-566</b>		

ELECTRICAL SYSTEM.

3-96. STOPLAMP-TAILLAMP ASSEMBLY REPLACEMENT (Continued).

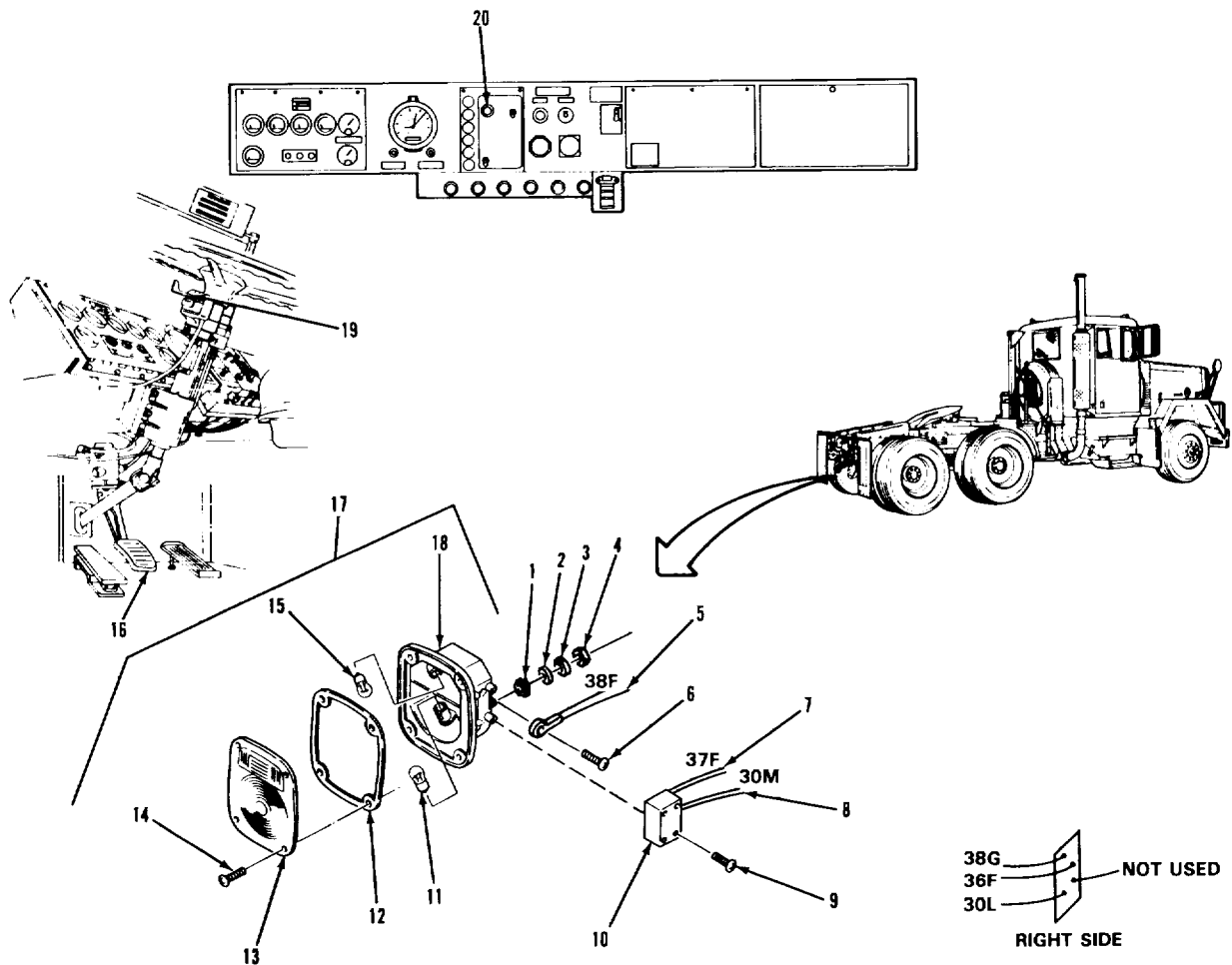

LEGEND:

- |                           |                                |
|---------------------------|--------------------------------|
| 1. LOCKWASHER             | 11. LAMP                       |
| 2. WASHER (2)             | 12. GASKET                     |
| 3. LOCKWASHER (2)         | 13. LENS                       |
| 4. NUT (2)                | 14. SCREW (4)                  |
| 5. WIRE (38F) (RIGHT 38G) | 15. LAMP                       |
| 6. SCREW (3)              | 16. BRAKE PEDAL                |
| 7. WIRE (37F) (RIGHT 36F) | 17. STOPLAMP-TAILLAMP ASSEMBLY |
| 8. WIRE (30M) (RIGHT 30L) | 18. HOUSING                    |
| 9. SCREW (4)              | 19. TURN SIGNAL CONTROL        |
| 10. COVER                 | 20. HEADLAMP SWITCH            |

TA 237258

**ELECTRICAL SYSTEM.**

<b>3-96. STOPLAMP-TAILLAMP ASSEMBLY REPLACEMENT (Continued)</b>		
<b>LOCATION/ITEM</b>	<b>ACTION</b>	<b>REMARKS</b>
<b>E. <u>STOPLAMP-TAILLAMP ASSEMBLY REASSEMBLY.</u></b>		
17. Lamp (15) and lamp (11).	Install.	Push in and turn a quarter turn to the right.
18. Lens (13) and gasket (12).	Align and install on top.	Window for backup lamp
19. Four screws (14).	Install and tighten.	
<b>F. <u>STOPLAMP-TAILLAMP ASSEMBLY INSTALLATION.</u></b>		
20. Wire (5), wire (7), and wire (8).	Install with three items (6). identification tags from step 11.	Connect according to
21. Cover (10) and tighten.	Fill with grease. Align	
22. Four screws (9).	Install and tighten.	
23. Stoplamp-tail-lamp assembly (17).	Align mounting studs and install.	
24. Two nuts (4), two lockwashers (3), two washers (2), and one lock-washer (1).	Install and tighten.	
<b>G. <u>STOPLAMP-TAILLAMP OPERATIONAL CHECK.</u></b>		
25. Headlamp switch (20).	Pull out to first stop.	First mechanic.
26. Stoplamp-tail-lamp assembly (17).	Verify that lights go on.	Second mechanic.



ELECTRICAL SYSTEM.

3-96. STOPLAMP-TAILLAMP ASSEMBLY REPLACEMENT (Continued).

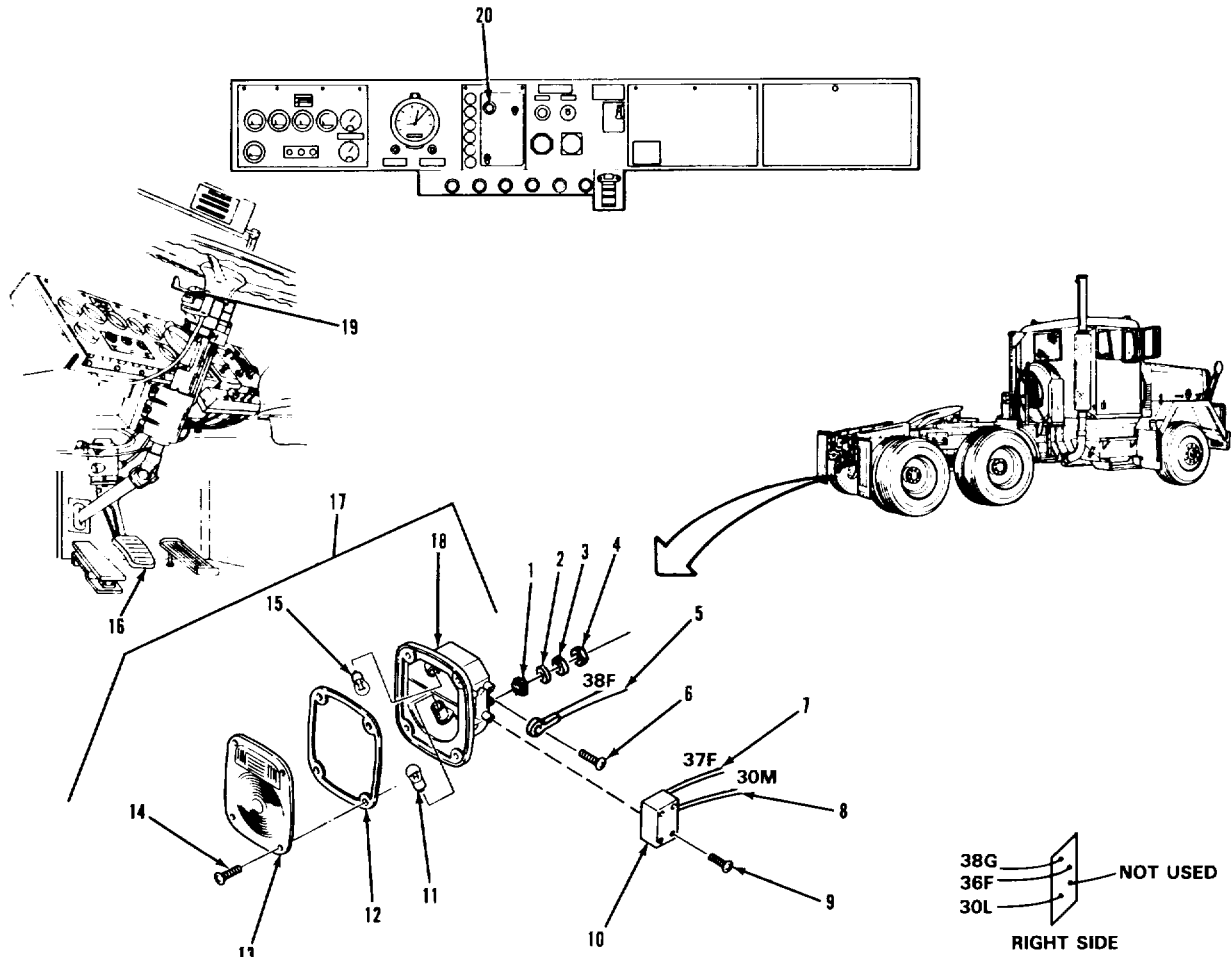

LEGEND:

- |                           |                                |
|---------------------------|--------------------------------|
| 1. LOCKWASHER             | 11. LAMP                       |
| 2. WASHER (2)             | 12. GASKET                     |
| 3. LOCKWASHER (2)         | 13. LENS                       |
| 4. NUT (2)                | 14. SCREW (4)                  |
| 5. WIRE (38F) (RIGHT 38G) | 15. LAMP                       |
| 6. SCREW (3)              | 16. BRAKE PEDAL                |
| 7. WIRE (37F) (RIGHT 36F) | 17. STOPLAMP-TAILLAMP ASSEMBLY |
| 8. WIRE (30M) (RIGHT 30L) | 18. HOUSING                    |
| 9. SCREW (4)              | 19. TURN SIGNAL CONTROL        |
| 10. COVER                 | 20. HEADLAMP SWITCH            |

## ELECTRICAL SYSTEM.

3-96. STOPLAMP TAILLAMP ASSEMBLY REPALCEMENT (Continued).		
LOCATION/ITEM	ACTION	REMARKS
<b>G. STOPLAMP-TAILLAMP OPERATIONAL CHECK (Continued).</b>		
27. Brake pedal (16).	Press down.	First mechanic.
28. Stoplamp-taillamp assembly (17).	Verify that brake lights go on.	Second mechanic.
29. Turn signal control (9).	Press down lever.	First mechanic.
30. Stoplamp-taillamp assembly (17).	Verify that left turn signal comes on.	Second mechanic.
31. Turn signal control (19).	Push lever up.	First mechanic.
32. Stoplamp-taillamp assembly (17).	Verify that right turn signal comes on.	Second mechanic.
<b>NOTE</b>		
Follow-on maintenance action required: None.		
<b>3-570</b>		

ELECTRICAL SYSTEM.

3-96. STOPLAMP-TAILLAMP ASSEMBLY REPLACEMENT (Continued).

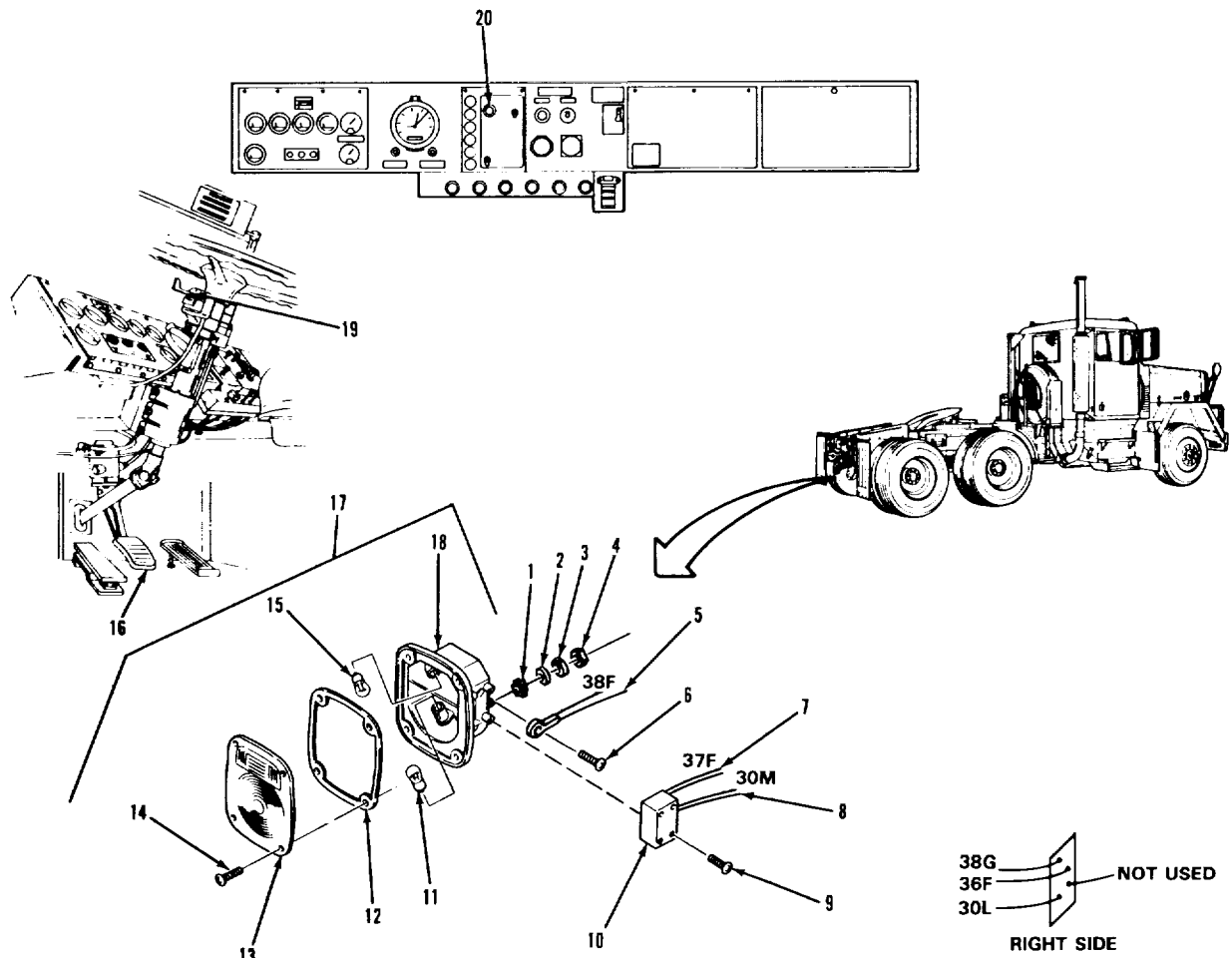

LEGEND:

- |                           |                                |
|---------------------------|--------------------------------|
| 1. LOCKWASHER             | 11. LAMP                       |
| 2. WASHER (2)             | 12. GASKET                     |
| 3. LOCKWASHER (2)         | 13. LENS                       |
| 4. NUT (2)                | 14. SCREW (4)                  |
| 5. WIRE (38F) (RIGHT 38G) | 15. LAMP                       |
| 6. SCREW (3)              | 16. BRAKE PEDAL                |
| 7. WIRE (37F) (RIGHT 36F) | 17. STOPLAMP-TAILLAMP ASSEMBLY |
| 8. WIRE (30M) (RIGHT 30L) | 18. HOUSING                    |
| 9. SCREW (4)              | 19. TURN SIGNAL CONTROL        |
| 10. COVER                 | 20. HEADLAMP SWITCH            |

**ELECTRICAL SYSTEM.**

**3-97. BLACKOUT TAILLAMP ASSEMBLY REPLACEMENT.**

THIS TASK COVERS

- a. Blackout Taillamp Removal.
- b. Blackout Taillamp Installation.
- c. Blackout Taillamp Assembly Removal.
- d. Blackout Taillamp Assembly Disassembly.
- e. Blackout Taillamp Assembly Reassembly.
- f. Blackout Taillamp Assembly Installation.
- g. Blackout Taillamp Assembly Operational Check.

INITIAL SETUP

<p><u>APPLICABLE CONFIGURATIONS</u> All.</p>	<p><u>EQUIPMENT CONDITION PARAGRAPH</u> TM 9-2320-283-10.</p>	<p><u>CONDITION DESCRIPTION</u> Headlamp switch off.</p>
<p><u>TEST EQUIPMENT</u> None.</p>	<p>TM 9-2320-283-10. set to normal.</p>	<p>Blackout toggle switch</p>
<p><u>SPECIAL TOOLS</u> None.</p>		
<p><u>MATERIALS/PARTS (P/N)</u> None.</p>		
<p><u>PERSONNEL REQUIRED</u> Two (MOS-63S .</p>	<p><u>SPECIAL ENVIRONMENTAL CONDITIONS</u> None.</p>	
<p><u>REFERENCES (TM)</u> TM 9-2320-283-10.</p>	<p><u>GENERAL SAFETY INSTRUCTIONS</u> Engine off. Transmission in neutral. Park brake set.</p>	
<p><u>TROUBLESHOOTING REFERENCES</u> Paragraph 2-11.</p>		

ELECTRICAL SYSTEM.

3-97. BLACKOUT TAILLAMP ASSEMBLY REPLACEMENT (Continued).

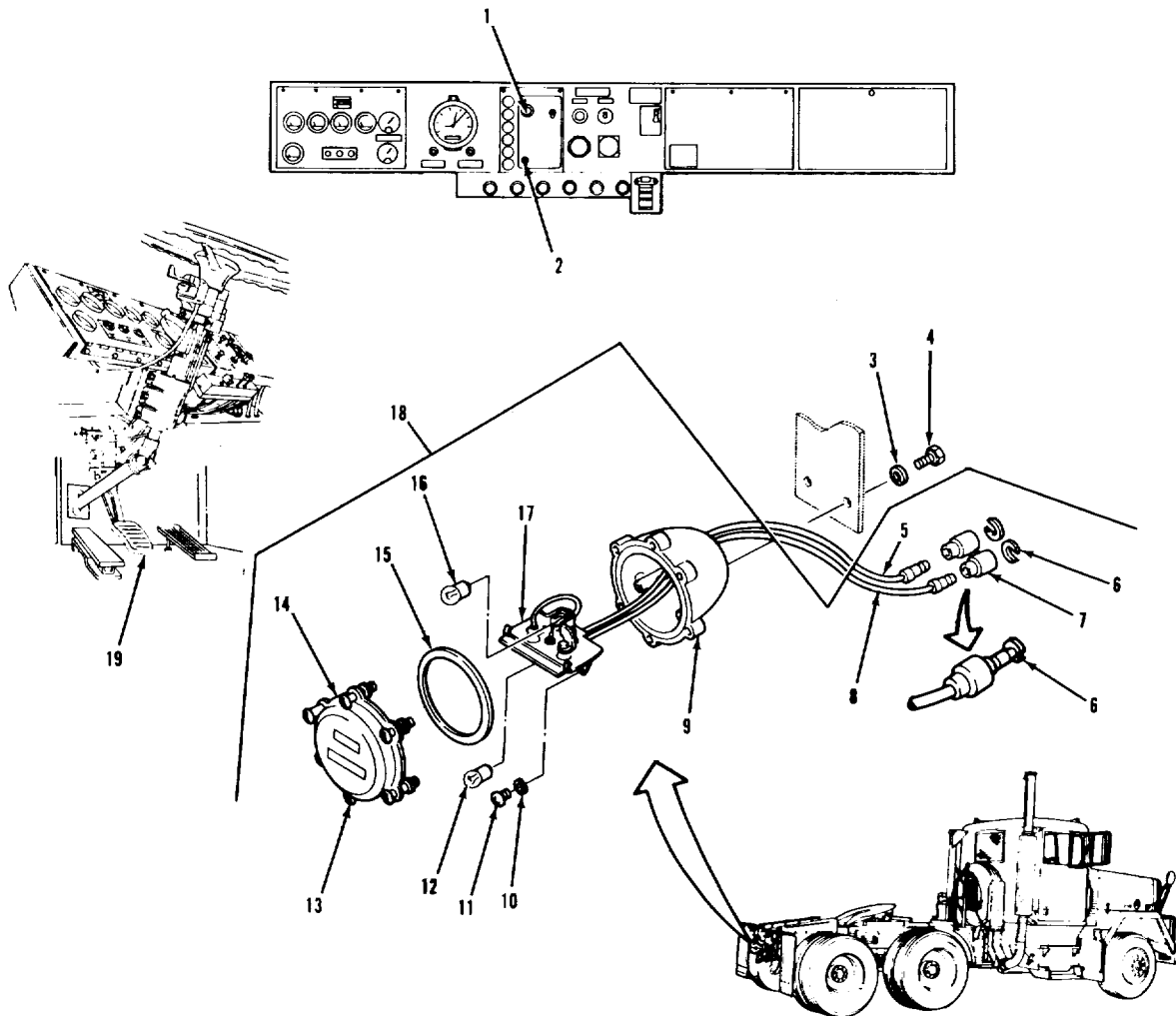

LEGEND:

- |                                     |                                |
|-------------------------------------|--------------------------------|
| 1. HEADLAMP SWITCH                  | 11. SCREW (2)                  |
| 2. BLACKOUT TOGGLE SWITCH           | 12. LAMP                       |
| 3. LOCKWASHER (2)                   | 13. SCREW (6)                  |
| 4. SCREW (2)                        | 14. DOOR                       |
| 5. WIRE CONNECTOR (24B) (RIGHT-24B) | 15. PREFORMED PACKING          |
| 6. SLOTTED WASHER (2)               | 16. LAMP                       |
| 7. SHELL (2)                        | 17. LAMPHOLDER                 |
| 8. WIRE CONNECTOR (23V) (RIGHT-23W) | 18. BLACKOUT TAILLAMP ASSEMBLY |
| 9. HOUSING                          | 19. BRAKE PEDAL                |
| 10. LOCKWASHER (2)                  |                                |

**ELECTRICAL SYSTEM.**

<b>3-97. BLACKOUT TAILLAMP ASSEMBLY REPLACEMENT (Continued)</b>		
<b>LOCATION/ITEM</b>	<b>ACTION</b>	<b>REMARKS</b>
<b>NOTE</b>		
Blackout taillamp assembly replacement procedures are the same for both sides. This procedure covers replacement of the left side blackout taillamp assembly.		
<b>A. <u>BLACKOUT TAILLAMP REMOVAL.</u></b>		
1. Six screws (13).	Loosen.	Six items (13) cannot be removed from item (14).
2. Door (14).	Remove.	
3. Preformed packing (15).	Remove.	Use small blade screwdriver. Discard item (15) if cracked or torn.
4. Stoplamp (16).	Remove.	Push in and turn a quarter turn to the left.
5. Taillamp (12).	Remove.	Push in and turn a quarter turn to the left.
<b>B. <u>BLACKOUT TAILLAMP INSTALLATION.</u></b>		
6. Stoplamp (12).	Install.	Push in and turn a quarter turn to the right.
7. Taillamp (16).	Install.	Push in and turn a quarter turn to the right.
8. Preformed packing (15).	Install in item (14).	
9. Door (14) with six screws (13).	Align and install to item (9). Tighten six items (13).	
<b>3-574</b>		

ELECTRICAL SYSTEM.

3-97. BLACKOUT TAILLAMP ASSEMBLY REPLACEMENT (Continued).

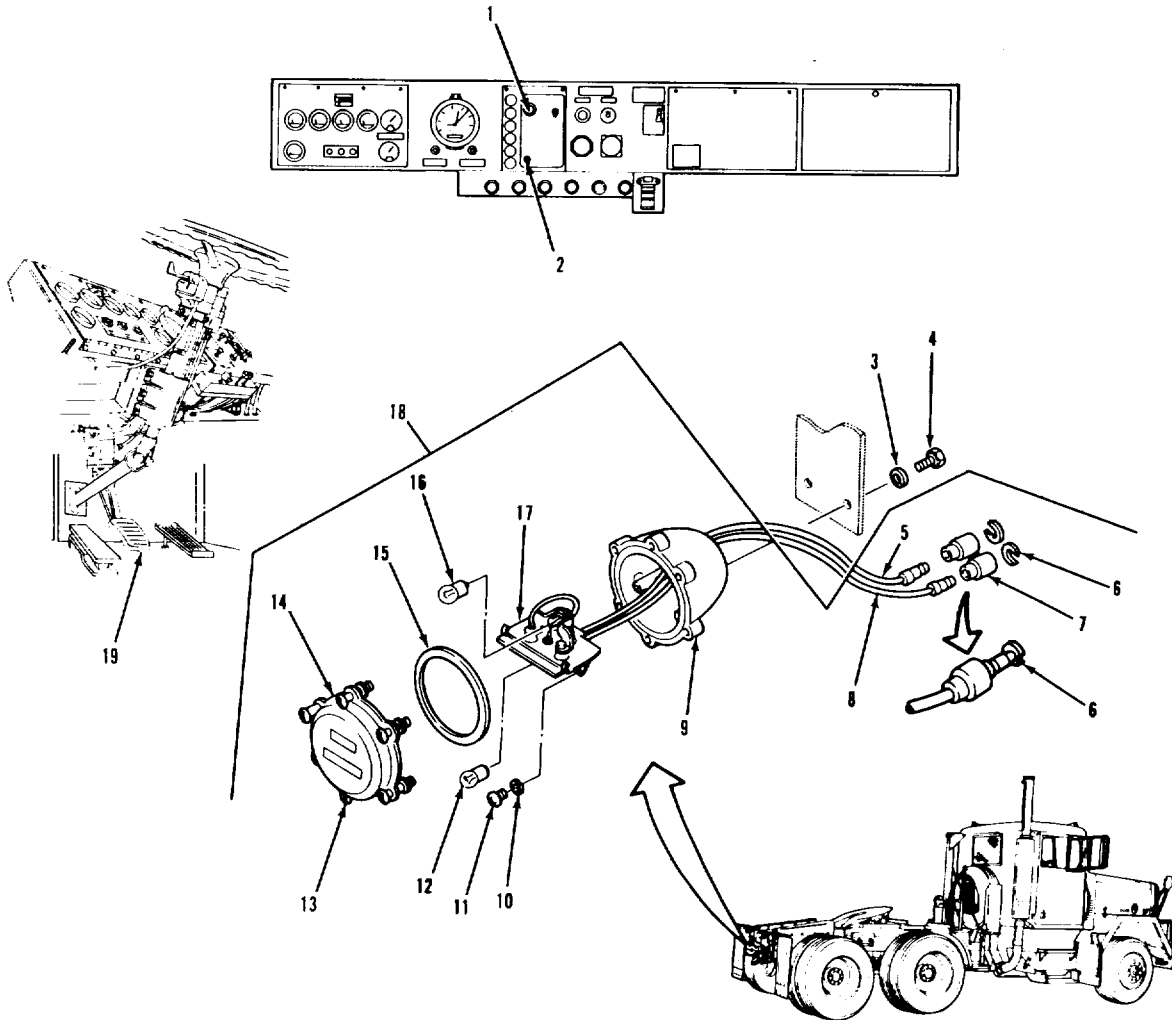

LEGEND:

- |                                     |                                |
|-------------------------------------|--------------------------------|
| 1. HEADLAMP SWITCH                  | 11. SCREW (2)                  |
| 2. BLACKOUT TOGGLE SWITCH           | 12. LAMP                       |
| 3. LOCKWASHER (2)                   | 13. SCREW (6)                  |
| 4. SCREW (2)                        | 14. DOOR                       |
| 5. WIRE CONNECTOR (24B) (RIGHT-24B) | 15. PREFORMED PACKING          |
| 6. SLOTTED WASHER (2)               | 16. LAMP                       |
| 7. SHELL (2)                        | 17. LAMPHOLDER                 |
| 8. WIRE CONNECTOR (23V) (RIGHT-23W) | 18. BLACKOUT TAILLAMP ASSEMBLY |
| 9. HOUSING                          | 19. BRAKE PEDAL                |
| 10. LOCKWASHER (2)                  |                                |

**ELECTRICAL SYSTEM.**

<b>3-97. BLACKOUT TAILLAMP ASSEMBLY REPLACEMENT (Continued).</b>		
<b>LOCATION/ITEM</b>	<b>ACTION</b>	<b>REMARKS</b>
<b>C. <u>BLACKOUT TAILLAMP ASSEMBLY REMOVAL.</u></b>		
10. Wire connector (5) and wire connector (8).	Disconnect.	Tag for identification.
11. Two screws (4) and two lock-washers (3).	Loosen and remove.	
12. Blackout taillamp assembly (18).	Remove.	
<b>D. <u>BLACKOUT TAILLAMP ASSEMBLY DISASSEMBLY.</u></b>		
13. Two shells (7).	Slide back on items (5) and (8).	
14. Two slotted washers (6).	Remove two items (6) and two items (7).	
15. Door (14) with six screws (13). (9).	Loosen six items (13) and remove item (14) from item (9).	Six items (13) cannot be removed from item (14).
16. Preformed packing (15).	Remove from item (14).	Use small blade screwdriver. Discard item (15) if cracked or torn.
17. Lamp (12) and lamp (16). left.	Remove.	Push in and turn a quarter turn to the
18. Two screws (11) and two lock-washers (10).	Loosen and remove from item (9).	
19. Lampholder (17).	Remove.	Pull items (5) and (8) through back of item (9).



ELECTRICAL SYSTEM.

3-97. BLACKOUT TAILLAMP ASSEMBLY REPLACEMENT (Continued).

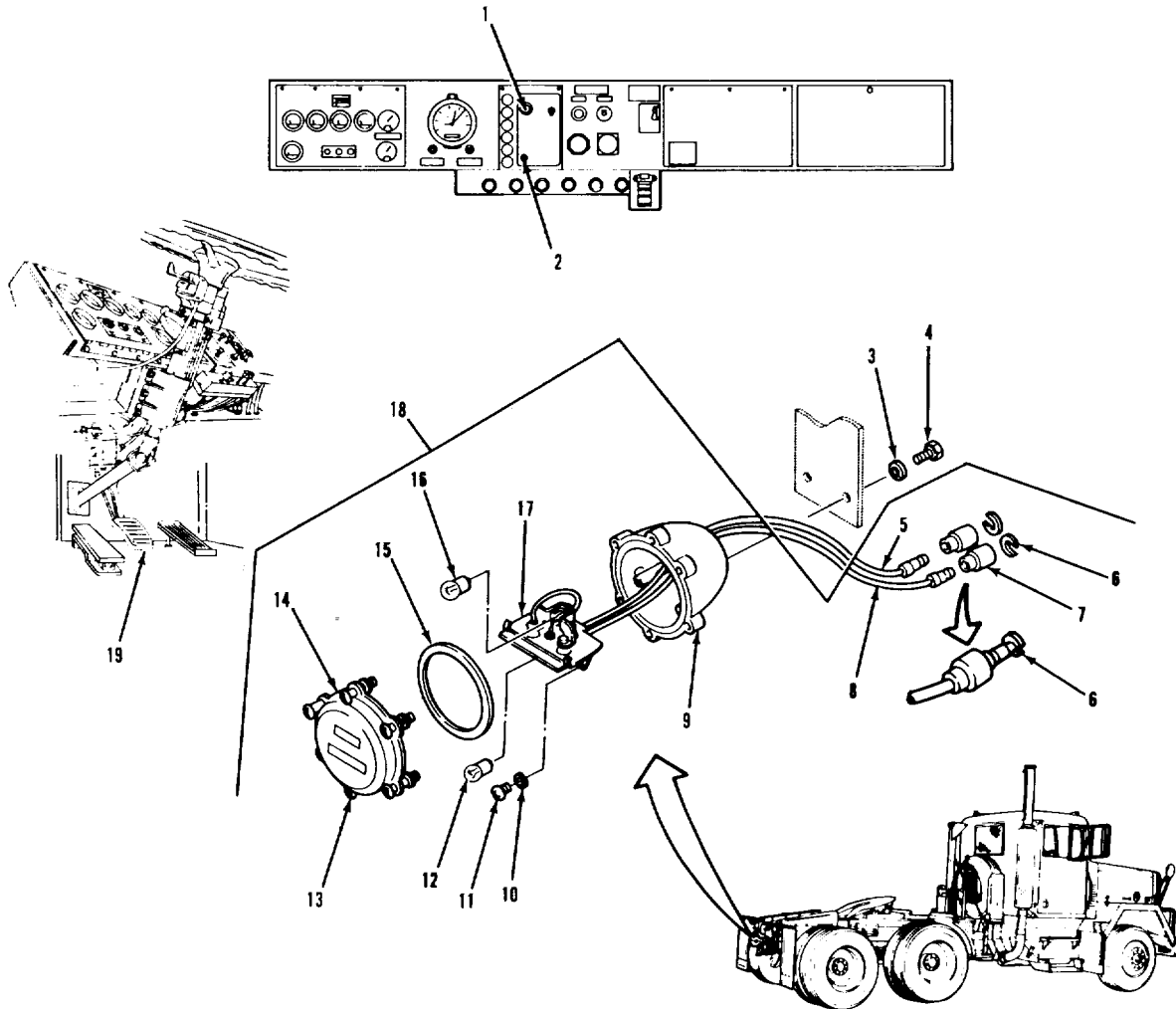

LEGEND:

- |                                     |                                |
|-------------------------------------|--------------------------------|
| 1. HEADLAMP SWITCH                  | 11. SCREW (2)                  |
| 2. BLACKOUT TOGGLE SWITCH           | 12. LAMP                       |
| 3. LOCKWASHER (2)                   | 13. SCREW (6)                  |
| 4. SCREW (2)                        | 14. DOOR                       |
| 5. WIRE CONNECTOR (24B) (RIGHT-24B) | 15. PREFORMED PACKING          |
| 6. SLOTTED WASHER (2)               | 16. LAMP                       |
| 7. SHELL (2)                        | 17. LAMPHOLDER                 |
| 8. WIRE CONNECTOR (23V) (RIGHT-23W) | 18. BLACKOUT TAILLAMP ASSEMBLY |
| 9. HOUSING                          | 19. BRAKE PEDAL                |
| 10. LOCKWASHER (2)                  |                                |

## ELECTRICAL SYSTEM.

3-97. BLACKOUT TAILLAMP ASSEMBLY REPLACEMENT (Continued)		
LOCATION/ITEM	ACTION	REMARKS
<b>E. <u>BLACKOUT TAILLAMP ASSEMBLY REASSEMBLY.</u></b>		
20. Wire connector (5) and wire connector (8).	Insert items (5) and (8) through back of item (9).	
21. Lampholder (17).	Install in item (9).	
22. Two screws (11) and two lock-washers (10).	Install and tighten.	
23. Lamp (12) and lamp (16).	Install.	Push in and turn a quarter turn to the right.
24. Preformed packing (15).	Install in item (14).	
25. Door (14) with six screws (13).	Align and install to item (9). Tighten six items (13).	
26. Two shells (7).	Install on items (5) and (8).	Slide back on items (5) and (8) to expose connectors.
27. Two slotted washers (6).	Install on items (5) and (8).	Prevents two items (7) from coming off.
28. Two shells (7).	Slide down on ends of item (5) and (8) until stopped by two items (6).	
<b>F. <u>BLACKOUT TAILLAMP ASSEMBLY INSTALLATION.</u></b>		
29. Blackout taillamp assembly (18).	Align with mounting holes.	

ELECTRICAL SYSTEM.

3-97. BLACKOUT TAILLAMP ASSEMBLY REPLACEMENT (Continued).

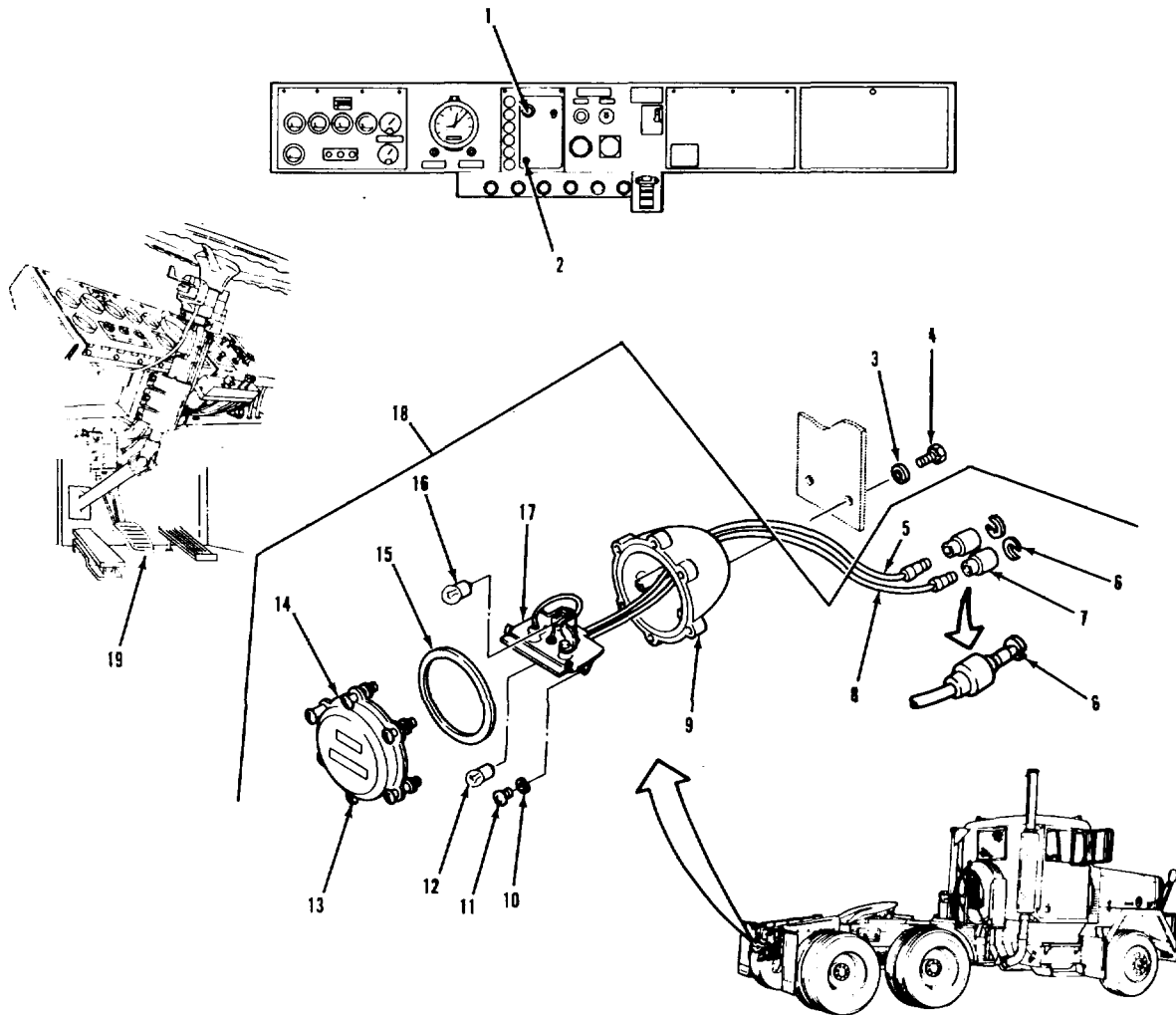

LEGEND:

- |                                     |                                |
|-------------------------------------|--------------------------------|
| 1. HEADLAMP SWITCH                  | 11. SCREW (2)                  |
| 2. BLACKOUT TOGGLE SWITCH           | 12. LAMP                       |
| 3. LOCKWASHER (2)                   | 13. SCREW (6)                  |
| 4. SCREW (2)                        | 14. DOOR                       |
| 5. WIRE CONNECTOR (24B) (RIGHT-24B) | 15. PREFORMED PACKING          |
| 6. SLOTTED WASHER (2)               | 16. LAMP                       |
| 7. SHELL (2)                        | 17. LAMPHOLDER                 |
| 8. WIRE CONNECTOR (23V) (RIGHT-23W) | 18. BLACKOUT TAILLAMP ASSEMBLY |
| 9. HOUSING                          | 19. BRAKE PEDAL                |
| 10. LOCKWASHER (2)                  |                                |

**ELECTRICAL SYSTEM.**

<b>3-97. BLACKOUT TAILLAMP ASSEMBLY REPLACEMENT (Continued)</b>		
<b>LOCATION/ITEM</b>	<b>ACTION</b>	<b>REMARKS</b>
<b>F. <u>BLACKOUT TAILLAMP ASSEMBLY INSTALLATION (Continued).</u></b>		
30. Two screws (4) and two lock-washers (3).	Install and tighten.	
31. Wire connector (5) and wire connector (8).	Connect.	Connect according to identification tag from step 10.
<b>G. <u>BLACKOUT TAILLAMP ASSEMBLY OPERATIONAL CHECK.</u></b>		
32. Blackout toggle switch (2).	Set to blackout.	First mechanic.
33. Headlamp switch (1).	Pull out to second stop.	First mechanic.
34. Blackout taillamp assembly (18).	Verify that both items (12) come on.	Second mechanic.
35. Brake pedal (19).	Press down.	First mechanic.
36. Blackout taillamp assembly (18).	Verify that both items (16) come on.	Second mechanic.
<b>NOTE</b>		
Follow-on maintenance action required: None.		
<b>3-580</b>		

ELECTRICAL SYSTEM.

3-97. BLACKOUT TAILLAMP ASSEMBLY REPLACEMENT (Continued).

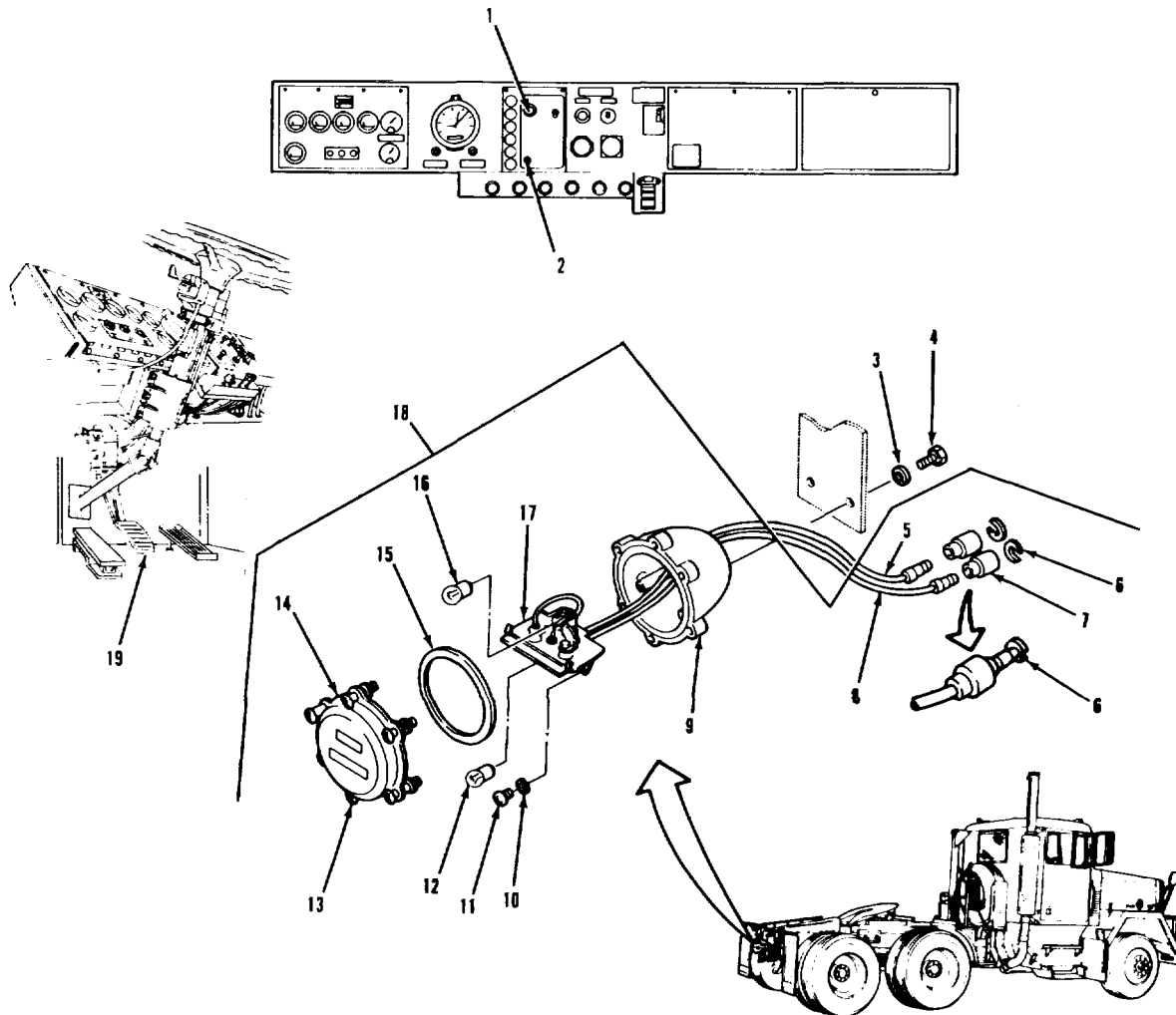

LEGEND:

- |                                     |                                |
|-------------------------------------|--------------------------------|
| 1. HEADLAMP SWITCH                  | 11. SCREW (2)                  |
| 2. BLACKOUT TOGGLE SWITCH           | 12. LAMP                       |
| 3. LOCKWASHER (2)                   | 13. SCREW (6)                  |
| 4. SCREW (2)                        | 14. DOOR                       |
| 5. WIRE CONNECTOR (24B) (RIGHT-24B) | 15. PREFORMED PACKING          |
| 6. SLOTTED WASHER (2)               | 16. LAMP                       |
| 7. SHELL (2)                        | 17. LAMPHOLDER                 |
| 8. WIRE CONNECTOR (23V) (RIGHT-23W) | 18. BLACKOUT TAILLAMP ASSEMBLY |
| 9. HOUSING                          | 19. BRAKE PEDAL                |
| 10. LOCKWASHER (2)                  |                                |

**ELECTRICAL SYSTEM.**

**3-98. DOME LAMP AND SWITCH REPLACEMENT.**

THIS TASK COVERS

- a. Dome Lamp Removal.
- b. Dome Lamp Installation.
- c. Dome Lamp and Switch Assembly Removal.
- d. Dome Lamp and Switch Assembly Installation.
- e. Dome Lamp and Switch Assembly Operational Check.

INITIAL SETUP

APPLICABLE CONFIGURATIONS

All.

EQUIPMENT CONDITION  
PARAGRAPH

TM 9-2320-283-10.

CONDITION DESCRIPTION

Blackout toggle switch  
set to normal.

TEST EQUIPMENT

None.

SPECIAL TOOLS

None.

MATERIALS/PARTS (P/N)

None.

PERSONNEL REQUIRED

One (MOS-63S).

SPECIAL ENVIRONMENTAL CONDITIONS

None.

REFERENCES (TM)

None.

GENERAL SAFETY INSTRUCTIONS

Engine off.  
Transmission in neutral.  
Park brake set.

TROUBLESHOOTING REFERENCES

Paragraph 2-11.

ELECTRICAL SYSTEM.

3-98. DOME LAMP AND SWITCH REPLACEMENT (Continued).

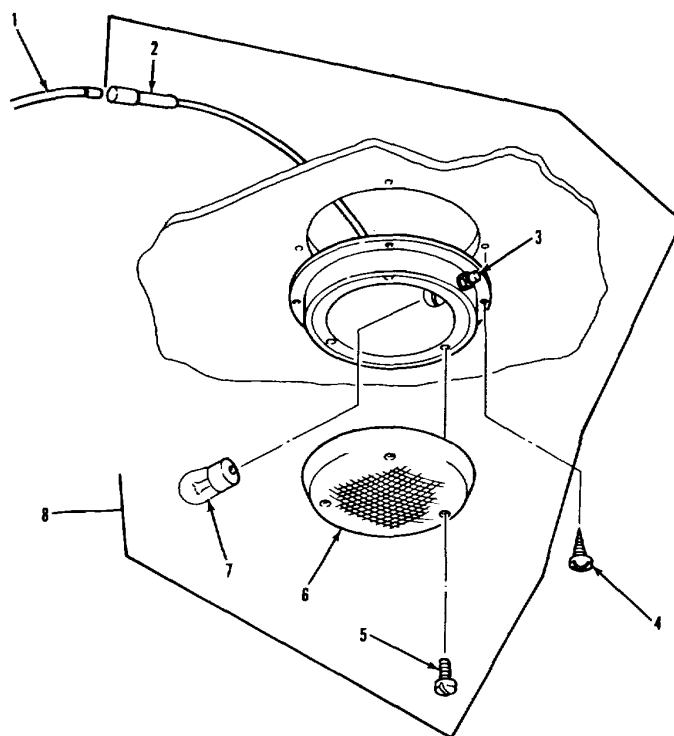

LEGEND:

- |                                      |                                  |
|--------------------------------------|----------------------------------|
| 1. WIRE (15B)                        | 5. SCREW (3)                     |
| 2. INSULATED CRIMP-ON BUTT CONNECTOR | 6. LENS                          |
| 3. SWITCH                            | 7. LAMP                          |
| 4. SCREW (2)                         | 8. DOME LAMP AND SWITCH ASSEMBLY |

TA 237266

**ELECTRICAL SYSTEM.**

<b>3-98. DOME LAMP AND SWITCH REPLACEMENT (Continued).</b>		
<b>LOCATION/ITEM</b>	<b>ACTION</b>	<b>REMARKS</b>
<b><u>A. DOME LAMP REMOVAL.</u></b>		
1. Three screws (5).	Remove.	
2. Lens (6).	Remove.	
3. Lamp (7).	Remove.	Push in and turn a quarter turn to the left.
<b><u>B. DOME LAMP INSTALLATION.</u></b>		
4. Lamp (7).	Install.	Push in and turn a quarter turn to the right.
5. Lens (6).	Aline and install.	
6. Three screws (5).	Install and tighten.	
<b><u>C. DOME LAMP AND SWITCH ASSEMBLY REMOVAL.</u></b>		
<b><u>WARNING</u></b>		
<b>Disconnect batteries before performing step (7). Failure to heed warning may result in serious personal injury or damage to vehicle wiring.</b>		
7. Two screws (4) removing two items (4).	Remove.	Hold item (8) while
8. Dome lamp and switch assembly (8).	Lower from roof of cab.	
9. Wire (1).	Cut where item (1) enters item (2).	Remove item (8).



ELECTRICAL SYSTEM.

3-98. DOME LAMP AND SWITCH REPLACEMENT (Continued).

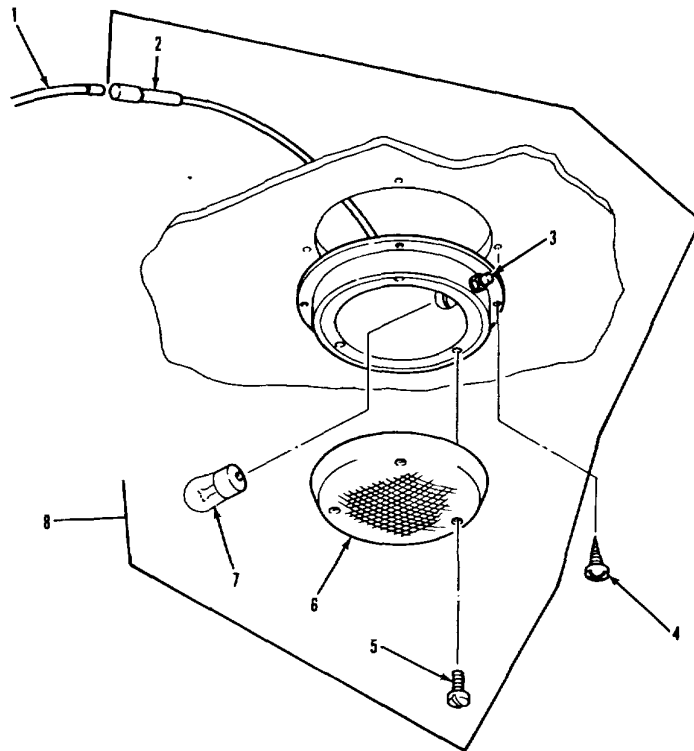

LEGEND:

- |                                      |                                  |
|--------------------------------------|----------------------------------|
| 1. WIRE (15B)                        | 5. SCREW (3)                     |
| 2. INSULATED CRIMP-ON BUTT CONNECTOR | 6. LENS                          |
| 3. SWITCH                            | 7. LAMP                          |
| 4. SCREW (2)                         | 8. DOME LAMP AND SWITCH ASSEMBLY |

TA 237267

**ELECTRICAL SYSTEM.**

<b>3-98. DOME LAMP AND SWITCH REPLACEMENT (Continued).</b>		
<b>LOCATION/ITEM</b>	<b>ACTION</b>	<b>REMARKS</b>
<b><u>D. DOME LAMP AND SWITCH ASSEMBLY INSTALLATION.</u></b>		
10. Wire (1).	Trim insulation back 0.375 inch from end.	
11. Dome lamp and switch assembly (8).	Raise into position about six inches from roof.	
12. Insulated crimp-on butt connector (2).	Insert bare end of item (1) into item (2) and crimp securely.	Use suitable crimping tool. Make sure that no bare wires are exposed after crimping item (2).
13. Dome lamp and switch assembly (8).	Aline and install.	
14. Two screws (4).	Install and tighten.	
15. Batteries.	Connect.	
<b><u>E. DOME LAMP AND SWITCH ASSEMBLY OPERATIONAL CHECK.</u></b>		
16. Switch (3).	Press twice. Verify that lamp comes on and goes off.	
<b>NOTE</b>		
<b>Follow-on maintenance action required:</b>		
<b>None.</b>		

ELECTRICAL SYSTEM.

3-98. DOME LAMP AND SWITCH REPLACEMENT (Continued).

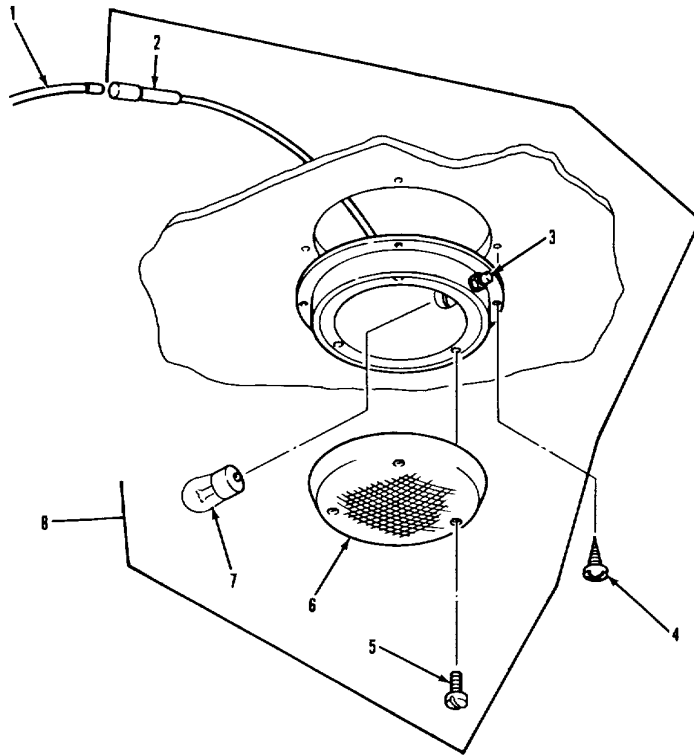

LEGEND:

- 1. WIRE (15B)
- 2. INSULATED CRIMP-ON BUTT CONNECTOR
- 3. SWITCH
- 4. SCREW (2)

- 5. SCREW (3)
- 6. LENS
- 7. LAMP
- 8. DOME LAMP AND SWITCH ASSEMBLY

TA 237268

**ELECTRICAL SYSTEM.**

<b>3-99. MAP LAMP AND SWITCH REPLACEMENT.</b>		
<u>THIS TASK COVERS</u>		
<ul style="list-style-type: none"> <li>a. Removal.</li> <li>b. Installation.</li> </ul>		
<u>INITIAL SETUP</u>		
<u>APPLICABLE CONFIGURATIONS</u>	<u>EQUIPMENT CONDITION PARAGRAPH</u>	<u>CONDITION DESCRIPTION</u>
All.	TM 9-2320-283-10.	Blackout toggle switch set to normal.
<u>TEST EQUIPMENT</u>		
None.		
<u>SPECIAL TOOLS</u>		
None.		
<u>MATERIALS/PARTS (P/N)</u>		
None.		
<u>PERSONNEL REQUIRED</u>	<u>SPECIAL ENVIRONMENTAL CONDITIONS</u>	
One (MOS-63S .	None.	
<u>REFERENCES (TM)</u>	<u>GENERAL SAFETY INSTRUCTIONS</u>	
None.	Engine off. Transmission in neutral. Park brake set.	
<u>TROUBLESHOOTING REFERENCES</u>		
Paragraph 2-11.		

ELECTRICAL SYSTEM.

3-99. MAP LAMP AND SWITCH REPLACEMENT (Continued).

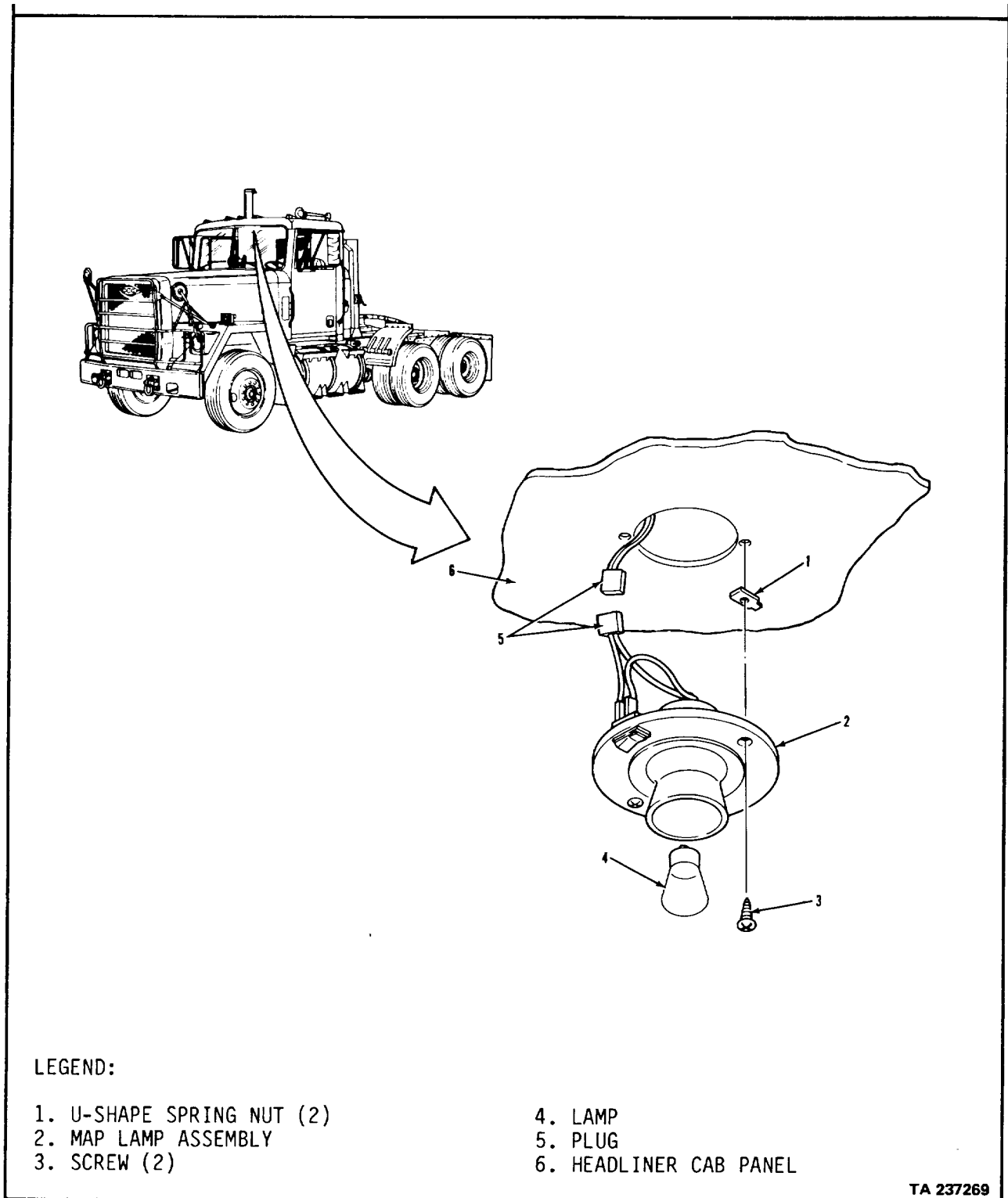

**ELECTRICAL SYSTEM.**

<b>3-99. MAP LAMP AND SWITCH REPLACEMENT (Continued).</b>		
<b>LOCATION/ITEM</b>	<b>ACTION</b>	<b>REMARKS</b>
<b>NOTE</b>		
<b>Replacement of map lamp and switch is the same for both sides.</b>		
<b><u>A. REMOVAL.</u></b>		
1. Lamp (4).	Remove from item (2).	Push in and unscrew.
2. Two screws (3).	Remove from item (2).	
3. Plug (5).	Disconnect.	
4. Two nuts (1).	Remove from item (6).	
<b><u>B. INSTALLATION.</u></b>		
5. Two nuts (1).	Install on item (6).	
6. Plug (5).	Connect.	
7. Lamp assembly (2).	Put in place on item (6).	
8. Two screws (3).	Secure item (2) to item (6).	
9. Lamp (4).	Install in item (2).	
<b>NOTE</b>		
<b>Follow-on maintenance action required:</b>		
None.		

ELECTRICAL SYSTEM.

3-99. MAP LAMP AND SWITCH REPLACEMENT (Continued).

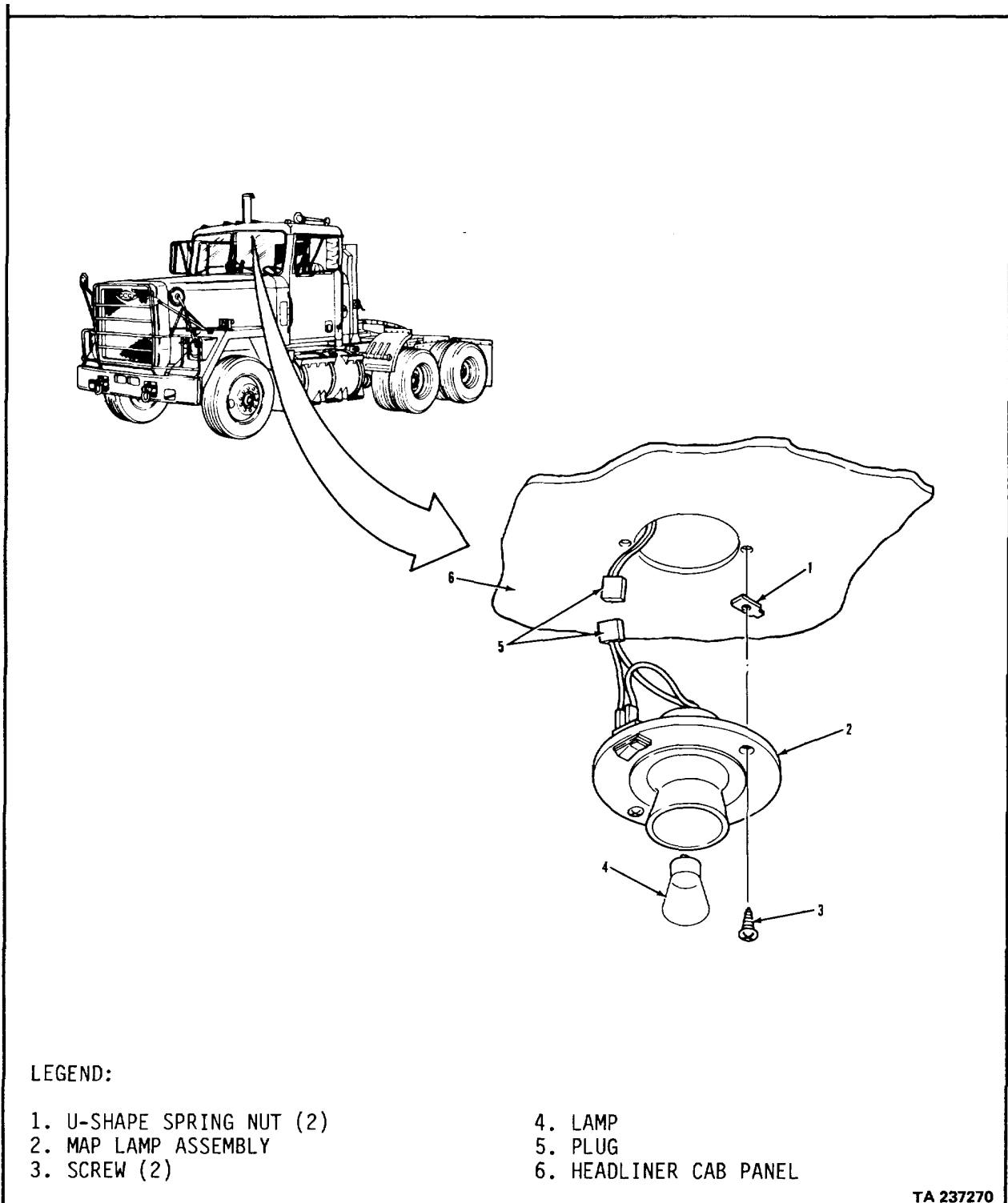

TA 237270

**ELECTRICAL SYSTEM.**

<b>3-100. HOT ENGINE TEMPERATURE SWITCH REPLACEMENT.</b>		
<u>THIS TASK COVERS</u>		
<ul style="list-style-type: none"> <li>a. Removal.</li> <li>b. Installation.</li> <li>c. Operational Check.</li> </ul>		
<u>INITIAL SETUP</u>		
<u>APPLICABLE CONFIGURATIONS</u>	<u>EQUIPMENT CONDITION PARAGRAPH</u>	<u>CONDITION DESCRIPTION</u>
All.	3-52.	Radiator drained below hot engine temperature switch level.
<u>TEST EQUIPMENT</u>		
None.	TM 9-2320-283-10.	Engine run switch off.
<u>SPECIAL TOOLS</u>		
None.		
<u>MATERIALS/PARTS (P/N)</u>		
Thread sealant, liquid Item 25, Appendix C.		
<u>PERSONNEL REQUIRED</u>	<u>SPECIAL ENVIRONMENTAL CONDITIONS</u>	
One (MOS-63S).	Vehicle parked on level ground.	
<u>REFERENCES (TM)</u>	<u>GENERAL SAFETY INSTRUCTIONS</u>	
TM 9-2320-283-10. TM 9-2320-283-20P.	Engine coolant at room temperature. Engine off. Transmission in neutral. Park brake set.	
<u>TROUBLESHOOTING REFERENCES</u>		
Paragraph 2-11.		



ELECTRICAL SYSTEM.

3-100. HOT ENGINE TEMPERATURE SWITCH REPLACEMENT (Continued).

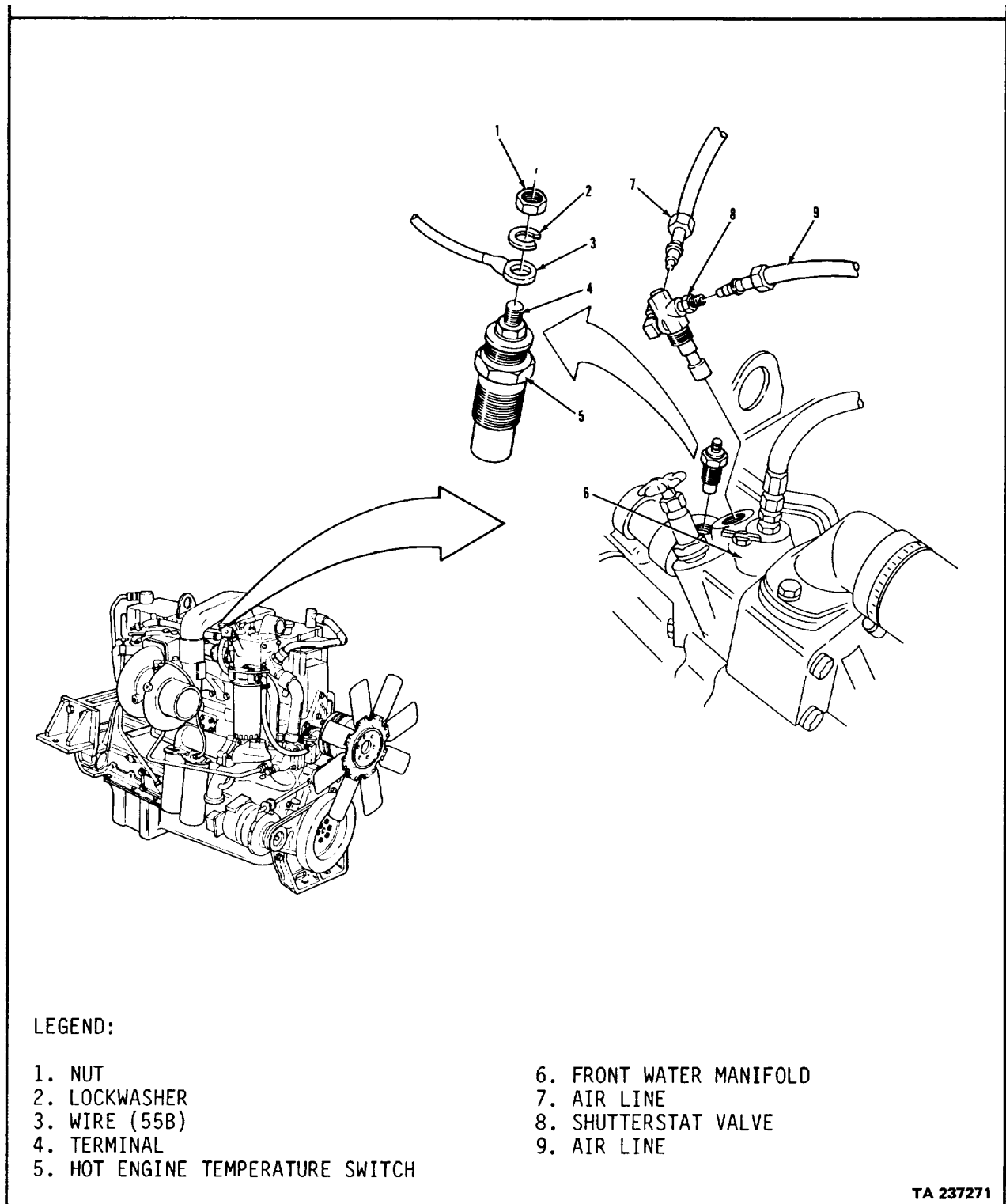

TA 237271

**ELECTRICAL SYSTEM.**

<b>3-100. HOT ENGINE TEMPERATURE SWITCH REPLACEMENT (Continued).</b>		
<b>LOCATION/ITEM</b>	<b>ACTION</b>	<b>REMARKS</b>
<b><u>A. REMOVAL.</u></b>		
1. Air line (7) and air line (9).	Disconnect.	Tag for identification.
2. Shutterstat valve (8).	Remove from item (6).	Retain for reassembly.
3. Nut (1) and lockwasher (2).	Remove from item (4).	
4. Wire (3).	Remove.	Tag for identification.
5. Hot engine temperature switch (5).	Remove.	Use deepwell socket and extension.
<b><u>B. INSTALLATION.</u></b>		
6. Hot engine temperature switch (5).	Coat threads with liquid thread sealant. Install and tighten.	Use deepwell socket and extension.
7. Wire (3).	Place on item (4).	Connect according to identification tag from step 4.
8. Lockwasher (2) and nut (1).	Install and tighten.	
9. Shutterstat valve (8.).	Coat threads with liquid thread sealant. Install and tighten.	
10. Air line (7) and air line (9).	Connect.	Connect according to identification tag from step 1.
<p><b><u>WARNING</u></b></p> <p><b>Do not operate engine without a supply of coolant in the cooling system. Failure to heed warning can result in engine damage.</b></p>		

ELECTRICAL SYSTEM.

3-100. HOT ENGINE TEMPERATURE SWITCH REPLACEMENT (Continued).

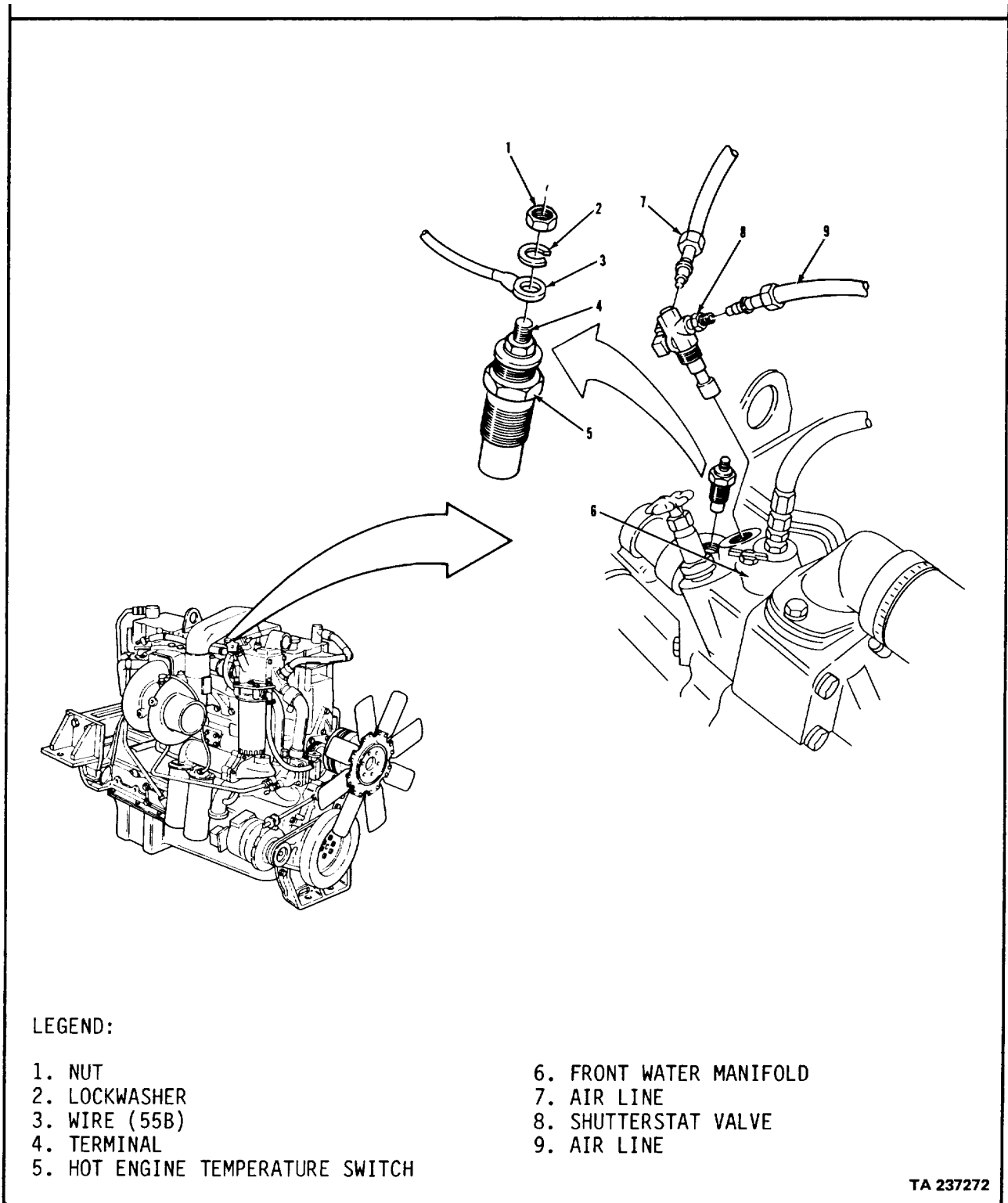

**ELECTRICAL SYSTEM.**

<b>3-100. HOT ENGINE TEMPERATURE SWITCH REPLACEMENT (Continued).</b>		
<b>LOCATION/ITEM</b>	<b>ACTION</b>	<b>REMARKS</b>
<b><u>D. OPERATIONAL CHECK.</u></b>		
11. Engine.	Start. Monitor water temperature gage. Switch should close and activate indicator	Refer to TM 9-2320-283-10. Shutdown engine after operational check. lamp when coolant reaches 225°F on gage.
<b><u>WARNING</u></b>		
<p><b>Let radiator cool before removing cap. Remove radiator cap in two steps. First, place a thick cloth over the cap and slowly rotate cap counterclockwise to its first stop; pause, and let pressure escape from the cooling system. Then rotate cap further counterclockwise until it can be removed. Failure to follow this procedure can result in burns and serious personal injury.</b></p>		
<b>NOTE</b>		
<p><b>Follow-on maintenance action required:</b></p> <p><b>Fill radiator (para 3-52). Check for coolant leaks around hot engine temperature switch and shutterstat valve. Tighten if necessary.</b></p>		

ELECTRICAL SYSTEM.

3-100. HOT ENGINE TEMPERATURE SWITCH REPLACEMENT (Continued).

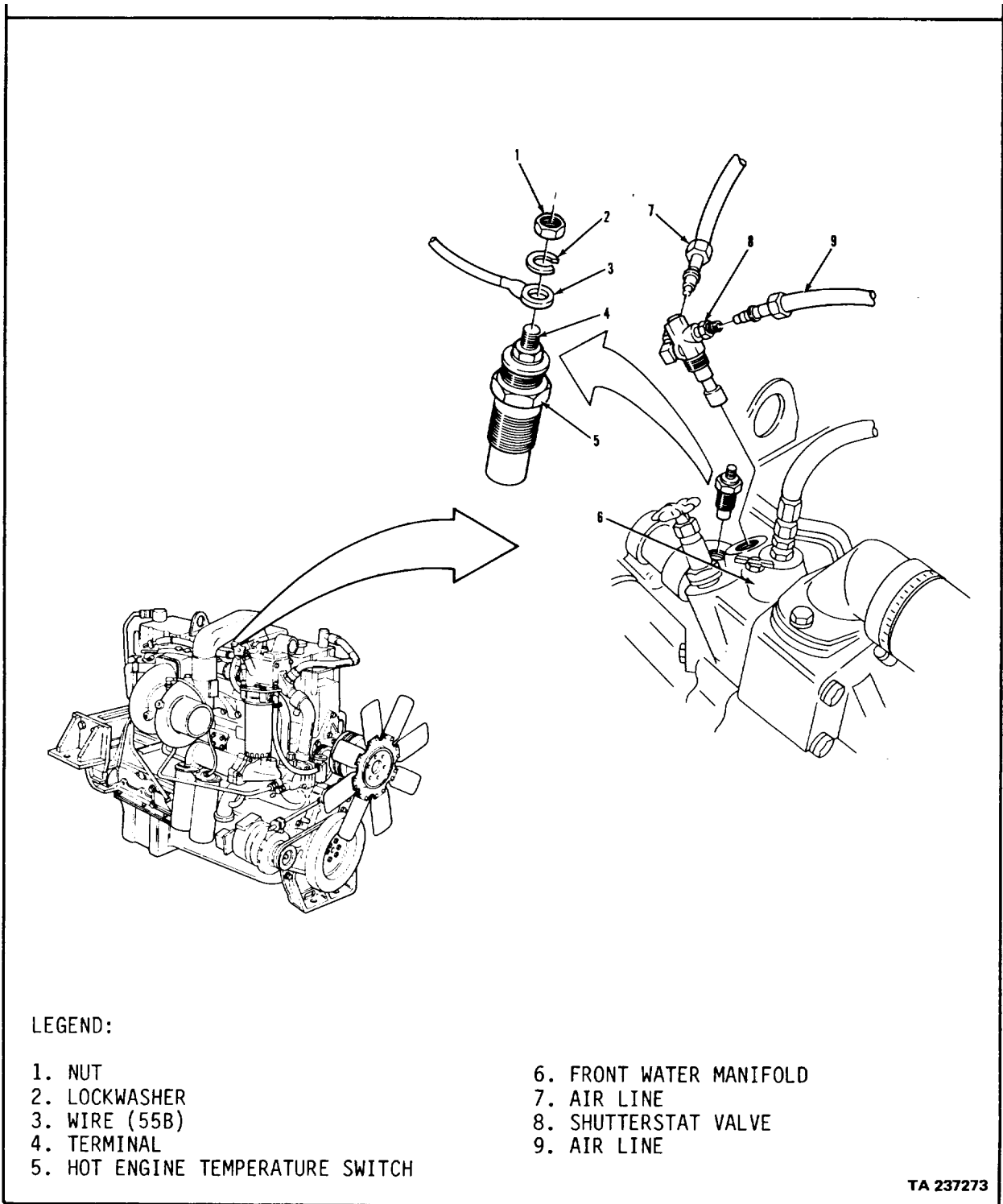

**ELECTRICAL SYSTEM.**

<b>3-101. WATER TEMPERATURE SENDING UNIT REPLACEMENT.</b>		
<u>THIS TASK COVERS</u>		
<ul style="list-style-type: none"> <li>a. Removal.</li> <li>b. Installation.</li> </ul>		
<u>INITIAL SETUP</u>		
<u>APPLICABLE CONFIGURATIONS</u>	<u>EQUIPMENT CONDITION PARAGRAPH</u>	<u>CONDITION DESCRIPTION</u>
All.	3-52.	Radiator drained below sending unit level.
<u>TEST EQUIPMENT</u>		
None.		
<u>SPECIAL TOOLS</u>		
None.		
<u>MATERIALS/PARTS (P/N)</u>		
Tape, thread sealing Item 32, Appendix C.		
<u>PERSONNEL REQUIRED</u>	<u>SPECIAL ENVIRONMENTAL CONDITIONS</u>	
One (MOS-63S ).	None.	
<u>REFERENCES (TM)</u>	<u>GENERAL SAFETY INSTRUCTIONS</u>	
TM 9-2320-283-10.	Engine off. Transmission in neutral. Park brake set.	
<u>TROUBLESHOOTING REFERENCES</u>		
Paragraph 2-11.		

ELECTRICAL SYSTEM.

3-101. WATER TEMPERATURE SENDING UNIT REPLACEMENT (Continued).

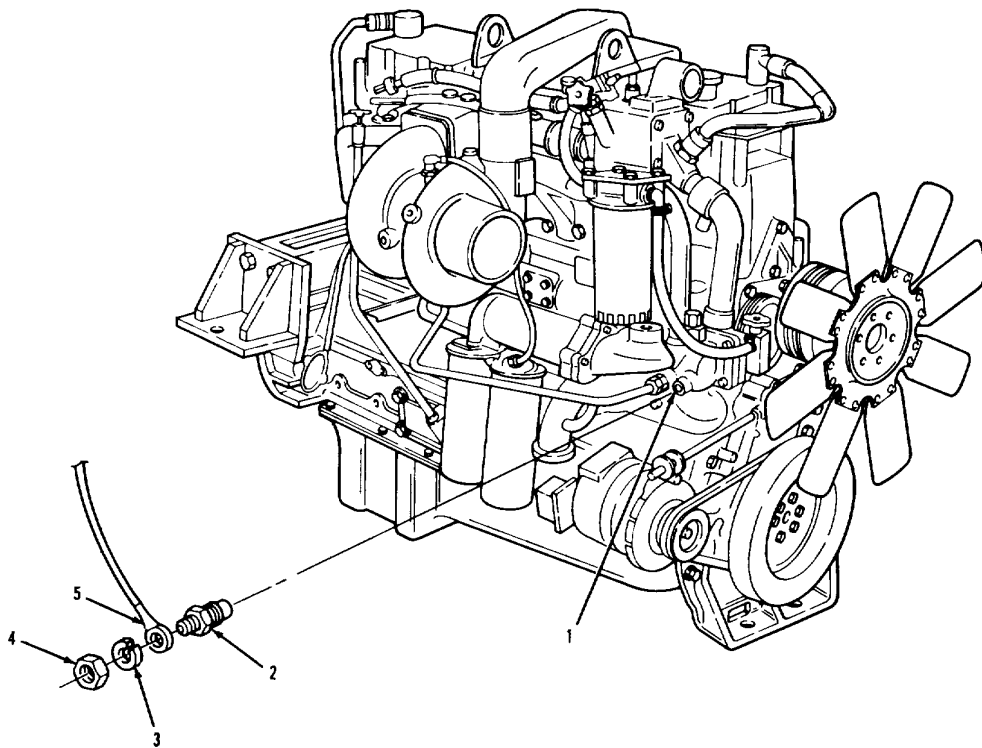

LEGEND:

- 1. WATER PUMP TO RADIATOR CONNECTION
- 2. WATER TEMPERATURE SENDING UNIT
- 3. LOCKWASHER
- 4. PLAIN NUT
- 5. WIRE (55E)

TA 237274

**ELECTRICAL SYSTEM.**

<b>3-101. WATER TEMPERATURE SENDING UNIT REPLACEMENT (Continued).</b>		
<b>LOCATION/ITEM</b>	<b>ACTION</b>	<b>REMARKS</b>
<b><u>A. REMOVAL.</u></b>		
1. Nut (4), lock-washer (3), and wire (5).	Remove from item (2).	
2. Unit (2).	Remove from item (1).	
<b><u>B. INSTALLATION.</u></b>		
3. Unit (2).	Install in item (1).	Put thread sealing tape on threads.
4. Nut (4) and lock-washer (3).	Secure item (5) to item (2).	
<b>NOTE</b>		
<b>Follow-on maintenance action required:</b>		
<b>Fill cooling system (TM 9-2320-283-10).</b>		



ELECTRICAL SYSTEM.

3-101. WATER TEMPERATURE SENDING UNIT REPLACEMENT (Continued).

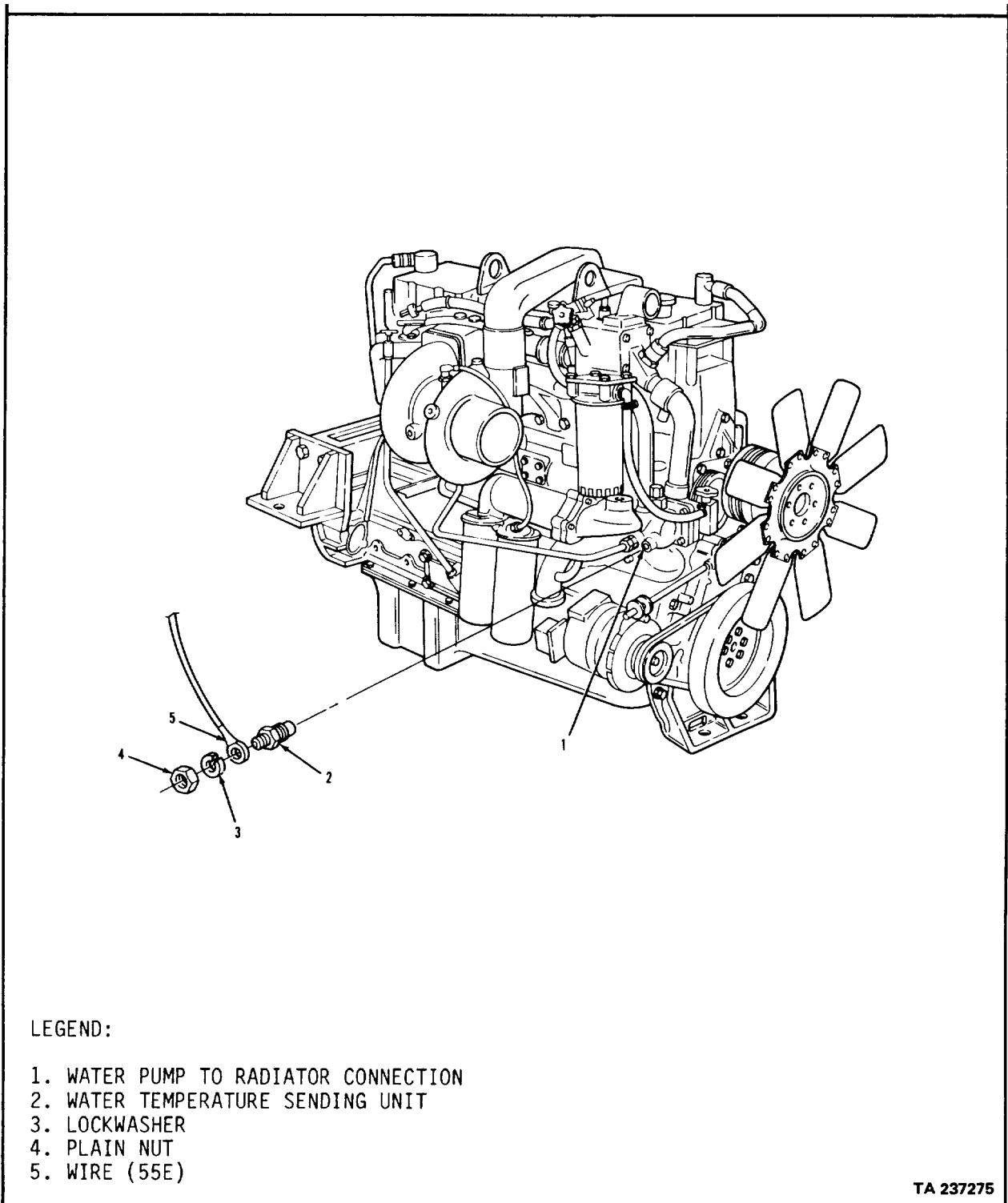

**ELECTRICAL SYSTEM.**

**3-102. OIL PRESSURE SENDING UNIT REPLACEMENT.**

THIS TASK COVERS

- a. Removal.
- b. Installation.

INITIAL SETUP

<p><u>APPLICABLE CONFIGURATIONS</u> All.</p>	<p><u>EQUIPMENT CONDITION PARAGRAPH</u> None.</p>	<p><u>CONDITION DESCRIPTION</u> None.</p>
<p><u>TEST EQUIPMENT</u> None.</p>		
<p><u>SPECIAL TOOLS</u> None.</p>		
<p><u>MATERIALS/PARTS (P/N)</u> Tape, thread sealing Item 32, Appendix C.</p>		
<p><u>PERSONNEL REQUIRED</u> One (MOS-63S).</p>	<p><u>SPECIAL ENVIRONMENTAL CONDITIONS</u> None.</p>	
<p><u>REFERENCES (TM)</u> None.</p>	<p><u>GENERAL SAFETY INSTRUCTIONS</u> Engine off. Transmission in neutral. Park brake set.</p>	
<p><u>TROUBLESHOOTING REFERENCES</u> Paragraph 2-11.</p>		

ELECTRICAL SYSTEM.

3-102. OIL PRESSURE SENDING UNIT REPLACEMENT (Continued).

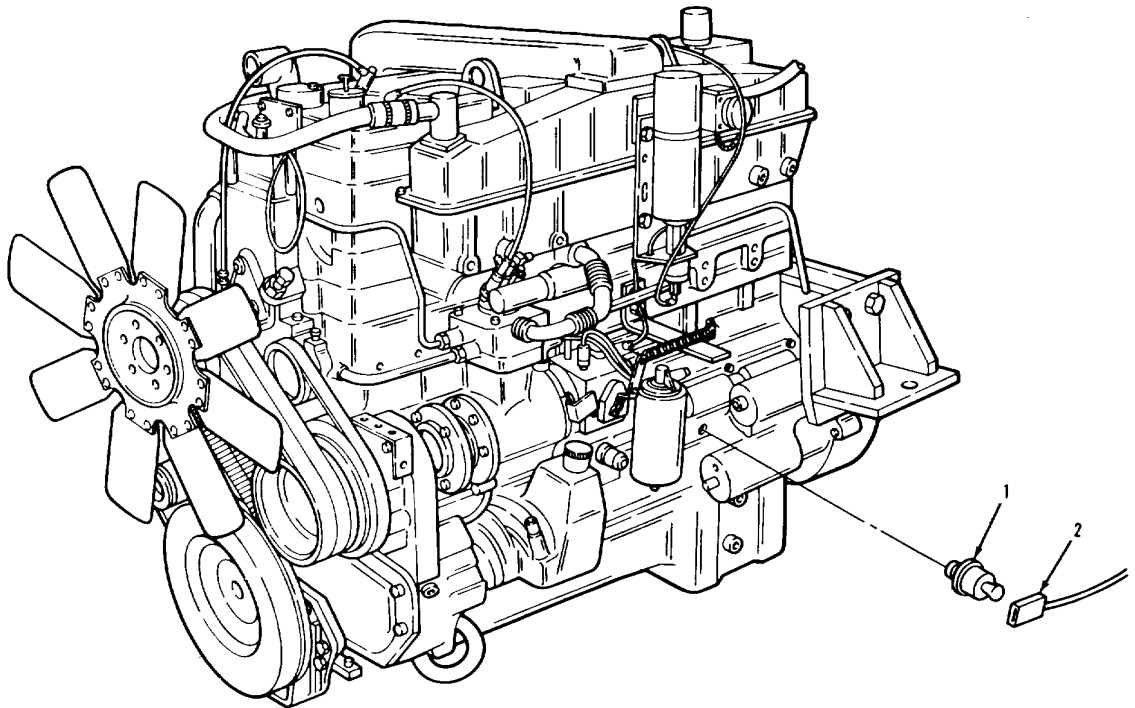

LEGEND:

- 1. OIL PRESSURE SENDING UNIT
- 2. WIRE (54C)

TA 237276

**ELECTRICAL SYSTEM.**

<b>3-102. OIL PRESSURE SENDING UNIT REPLACEMENT (Continued).</b>		
<b>LOCATION/ITEM</b>	<b>ACTION</b>	<b>REMARKS</b>
<b><u>A. REMOVAL.</u></b>		
1. Wire (2).	Remove from item (1).	
2. Unit (1).	Remove from engine.	
<b><u>B. INSTALLATION.</u></b>		
3. Unit (1).	Install in engine.	Put thread sealing tape on threads.
4. Wire (2).	Install on item (1).	
<b>NOTE</b>		
<b>Follow-on maintenance action required:</b>		
<b>None.</b>		

ELECTRICAL SYSTEM.

3-102. OIL PRESSURE SENDING UNIT REPLACEMENT (Continued).

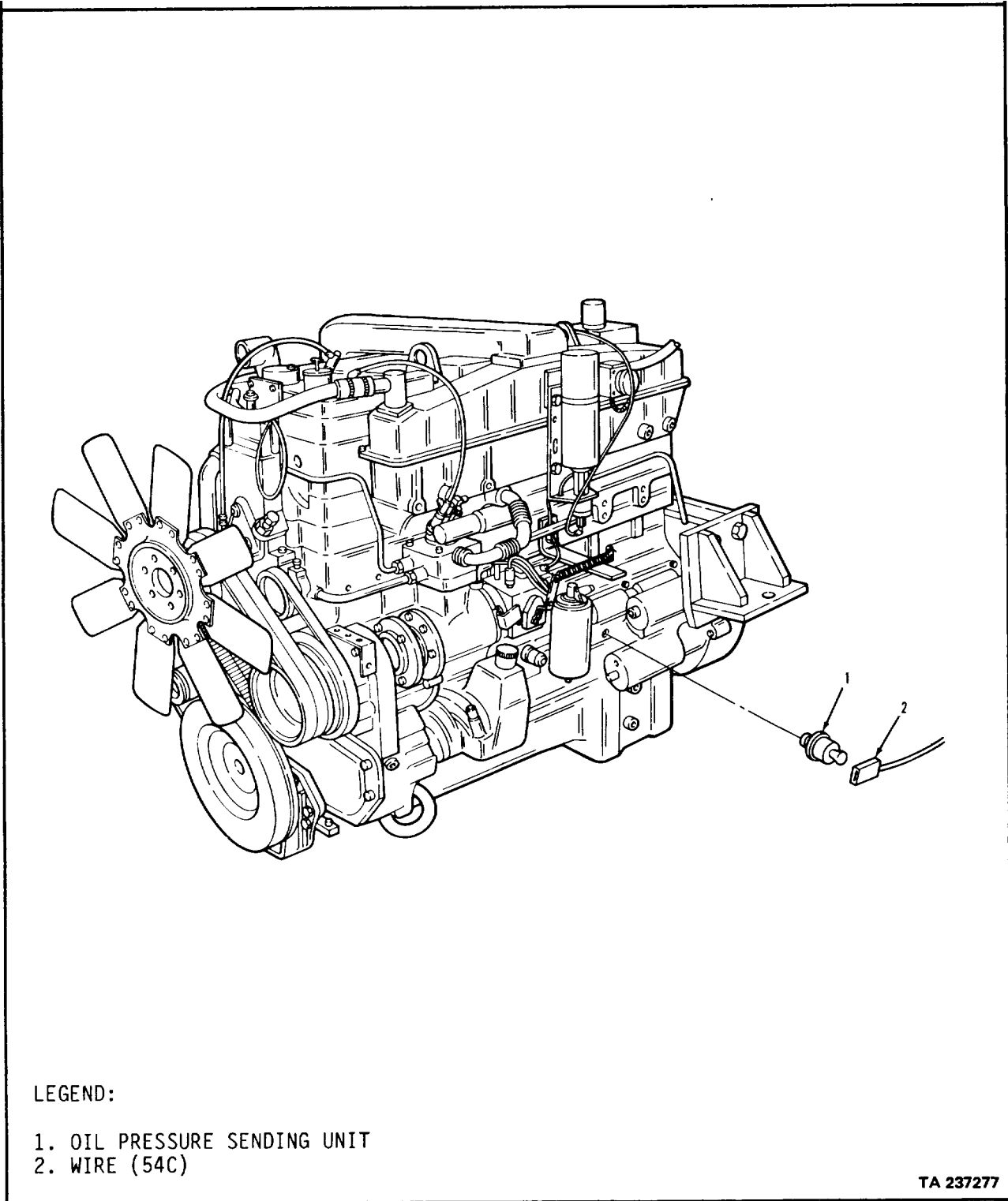

LEGEND:

- 1. OIL PRESSURE SENDING UNIT
- 2. WIRE (54C)

TA 237277

**ELECTRICAL SYSTEM.**

**3-103. TRANSMISSION TEMPERATURE SENDING UNIT REPLACEMENT.**

THIS TASK COVERS

- a. Removal.
- b. Installation.

INITIAL SETUP

<u>APPLICABLE CONFIGURATIONS</u> All.	<u>EQUIPMENT CONDITION PARAGRAPH</u> None.	<u>CONDITION DESCRIPTION</u> None.
<u>TEST EQUIPMENT</u> None.		
<u>SPECIAL TOOLS</u> None.		
<u>MATERIALS/PARTS (P/N)</u> Tape, thread sealing Item 32, Appendix C.		
<u>PERSONNEL REQUIRED</u> One (MOS-63S).	<u>SPECIAL ENVIRONMENTAL CONDITIONS</u> None.	
<u>REFERENCES (TM)</u> None.	<u>GENERAL SAFETY INSTRUCTIONS</u> Engine off. Transmission in neutral. Park brake set.	
<u>TROUBLESHOOTING REFERENCES</u> Paragraph 2-11.		

ELECTRICAL SYSTEM.

3-103. TRANSMISSION TEMPERATURE SENDING UNIT REPLACEMENT (Continued).

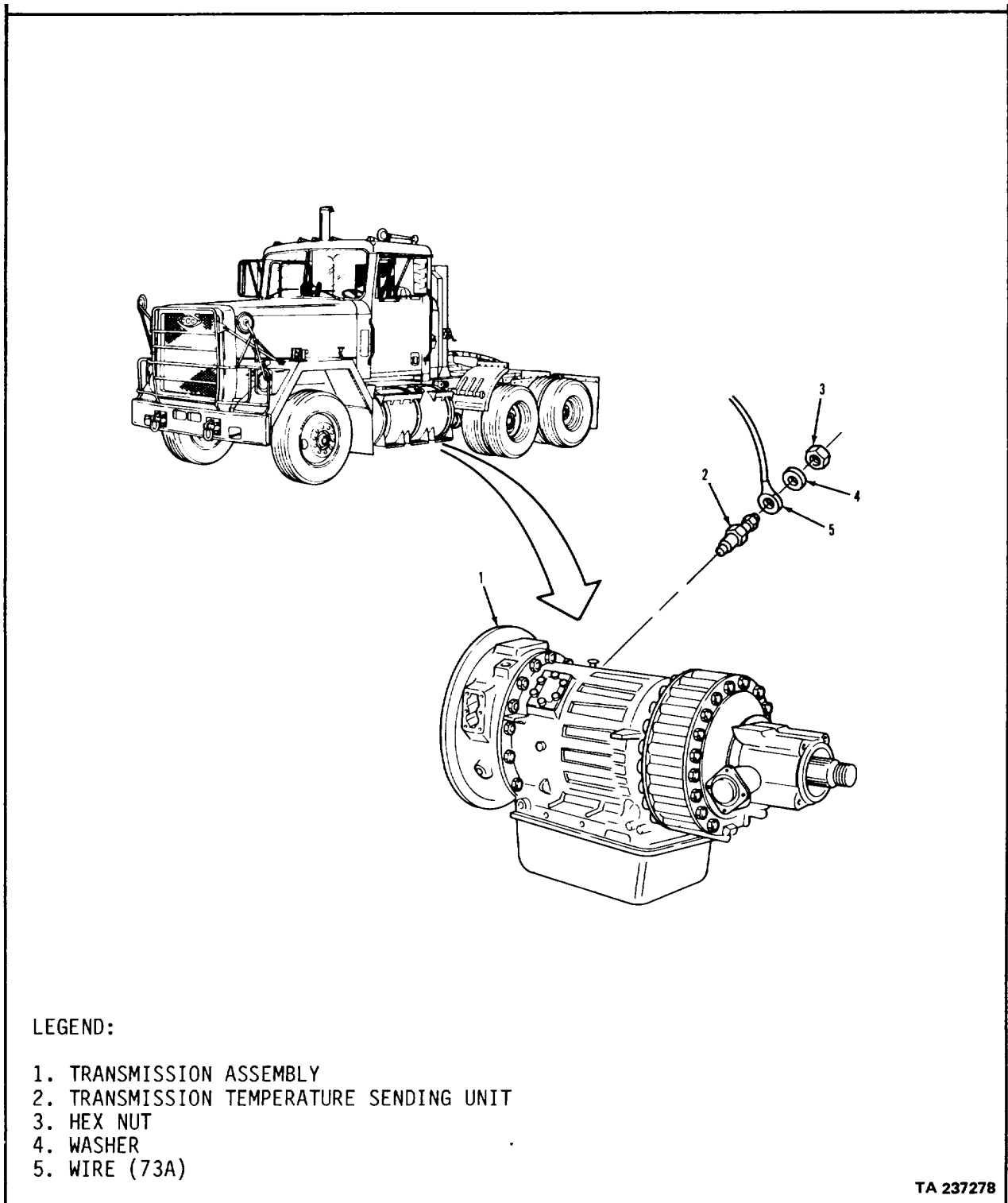

**ELECTRICAL SYSTEM.**

<b>3-103. TRANSMISSION TEMPERATURE SENDING UNIT REPLACEMENT (Continued).</b>		
<b>LOCATION/ITEM</b>	<b>ACTION</b>	<b>REMARKS</b>
<b><u>A. REMOVAL.</u></b>		
1. Nut (3), washer (4), and wire (5).	Remove from item (2).	
2. Unit (2).	Remove from item (1).	
<b><u>B. INSTALLATION.</u></b>		
3. Unit (2).	Install in item (1).	Put thread sealing tape on threads.
4. Nut (3) and washer (4).	Secure item (5) to item (2).	
<b>NOTE</b>		
<b>Follow-on maintenance action required:</b>		
<b>None.</b>		



ELECTRICAL SYSTEM.

3-103. TRANSMISSION TEMPERATURE SENDING UNIT REPLACEMENT (Continued).

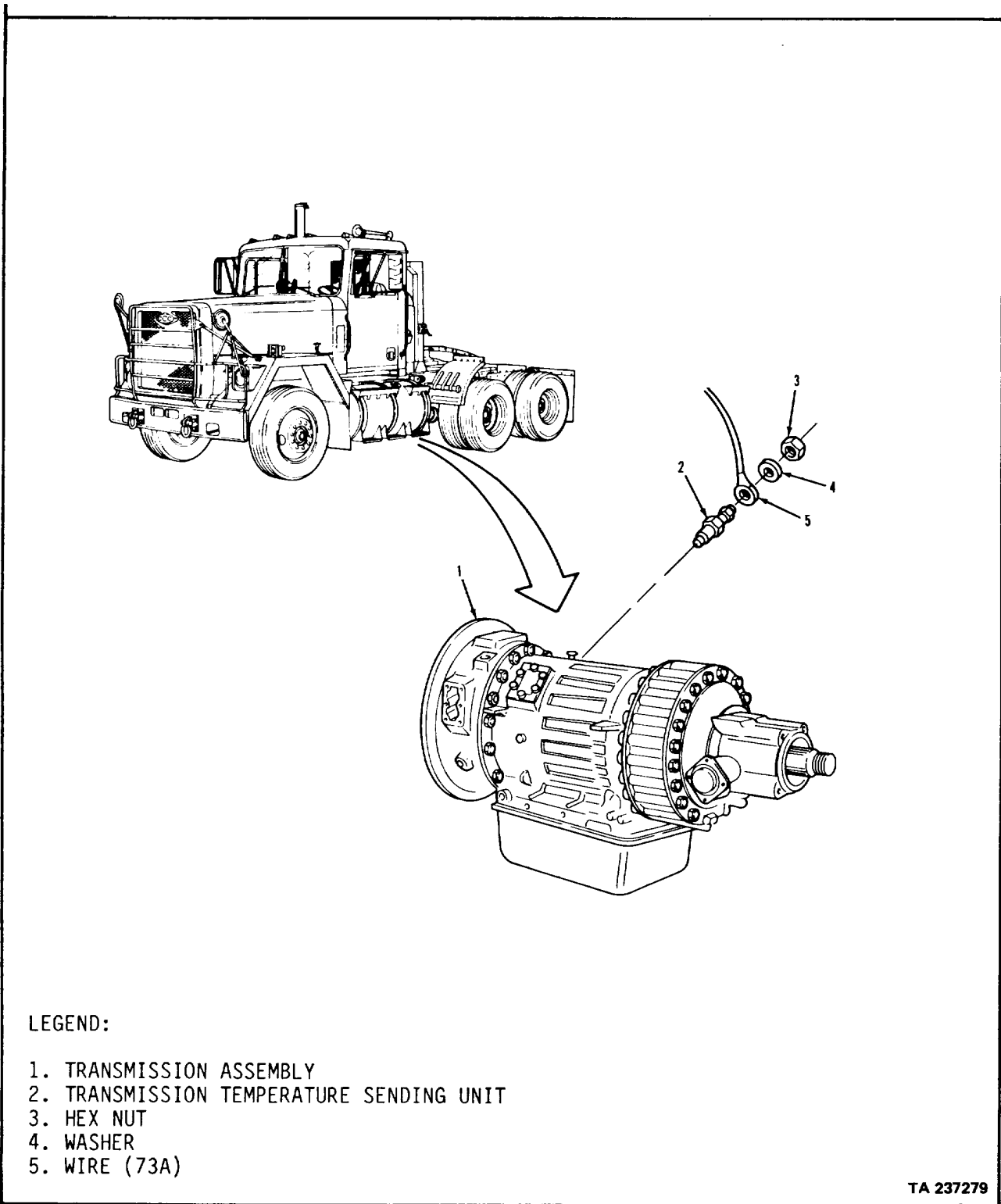

**ELECTRICAL SYSTEM.**

<b>3-104. LOW OIL PRESSURE SENDING UNIT REPLACEMENT.</b>		
<u>THIS TASK COVERS</u>		
<ul style="list-style-type: none"> <li>a. Removal.</li> <li>b. Installation.</li> </ul>		
<u>INITIAL SETUP</u>		
<u>APPLICABLE CONFIGURATIONS</u>	<u>EQUIPMENT CONDITION PARAGRAPH</u>	<u>CONDITION DESCRIPTION</u>
All.	None.	None.
<u>TEST EQUIPMENT</u>		
None.		
<u>SPECIAL TOOLS</u>		
None.		
<u>MATERIALS/PARTS (P/N)</u>		
Seal, O-ring (15434) 3030808.		
<u>PERSONNEL REQUIRED</u>	<u>SPECIAL ENVIRONMENTAL CONDITIONS</u>	
One (MOS-63S).	None.	
<u>REFERENCES (TM)</u>	<u>GENERAL SAFETY INSTRUCTIONS</u>	
TM 9-2320-283-20P.	Engine off. Transmission in neutral. Park brake set.	
<u>TROUBLESHOOTING REFERENCES</u>		
Paragraph 2-11.		

ELECTRICAL SYSTEM.

3-104. LOW OIL PRESSURE SENDING UNIT REPLACEMENT (Continued).

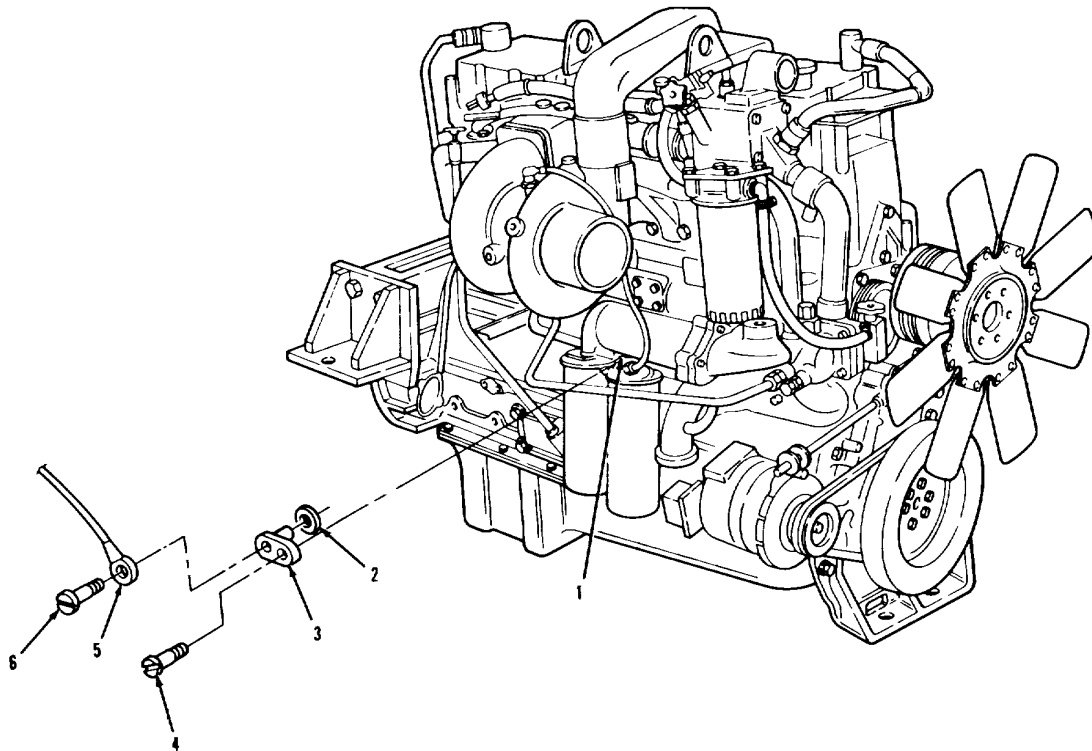

LEGEND:

- 1. OIL COOLER ASSEMBLY
- 2. O-RING SEAL
- 3. SENDING UNIT

- 4. PAN HEAD SCREW
- 5. WIRE (54A)
- 6. SCREW

TA 237280

**ELECTRICAL SYSTEM.**

<b>3-104. LOW OIL PRESSURE SENDING UNIT REPLACEMENT (Continued).</b>		
<b>LOCATION/ITEM</b>	<b>ACTION</b>	<b>REMARKS</b>
<b><u>A. REMOVAL.</u></b>		
1. Screw (6) and wire (5).	Remove from item (3).	
2. Screw (4).	Remove from item (3).	
3. Unit (3).	Remove from item (1).	
4. Seal (2).	Remove from item (3).	Discard item (2).
<b><u>B. INSTALLATION.</u></b>		
5. New seal (2).	Install on item (3).	
6. Unit (3).	Install in item (1).	
7. Screw (4).	Screw item (3) to item (1).	
8. Screw (6).	Secure item (5) to item (3).	
<b>NOTE</b>		
<b>Follow-on maintenance action required:</b>		
<b>None.</b>		

ELECTRICAL SYSTEM.

3-104. LOW OIL PRESSURE SENDING UNIT REPLACEMENT (Continued).

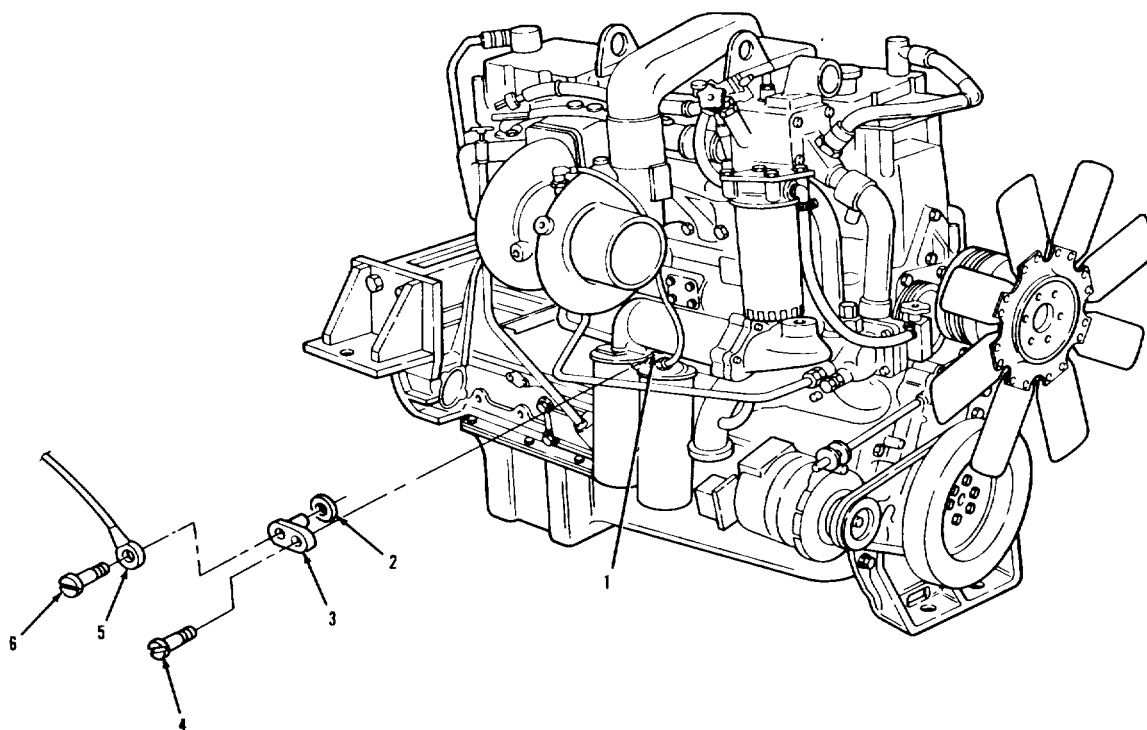

LEGEND:

- 1. OIL COOLER ASSEMBLY
- 2. O-RING SEAL
- 3. SENDING UNIT

- 4. PAN HEAD SCREW
- 5. WIRE (54A)
- 6. SCREW

TA 237281

ELECTRICAL SYSTEM.

**3-105. FUEL LEVEL SENDING UNIT REPLACEMENT.**

**THIS TASK COVERS**  
 a. Removal.  
 b. Installation.

<u>INITIAL SETUP</u>		
<u>APPLICABLE CONFIGURATIONS</u>	<u>EQUIPMENT CONDITION</u>	
All.	<u>PARAGRAPH</u> _____	<u>CONDITION DESCRIPTION</u>
	None.	None.
<u>TEST EQUIPMENT</u>		
None.		
<u>SPECIAL TOOLS</u>		
None.		
<u>MATERIALS/PARTS (P/N)</u>		
Gasket		
(98440) 2013.		
<u>PERSONNEL REQUIRED</u>	<u>SPECIAL ENVIRONMENTAL CONDITIONS</u>	
One (MOS-63S).	None.	
<u>REFERENCES (TM)</u>	<u>GENERAL SAFETY INSTRUCTIONS</u>	
TM 9-2320-283-20P.	Engine off.	
	Transmission in neutral.	
	Park brake set.	
<u>TROUBLESHOOTING REFERENCES</u>		
Paragraph 2-11.		
<b>3-614</b>		

ELECTRICAL SYSTEM.

3-105. FUEL LEVEL SENDING UNIT REPLACEMENT (Continued).

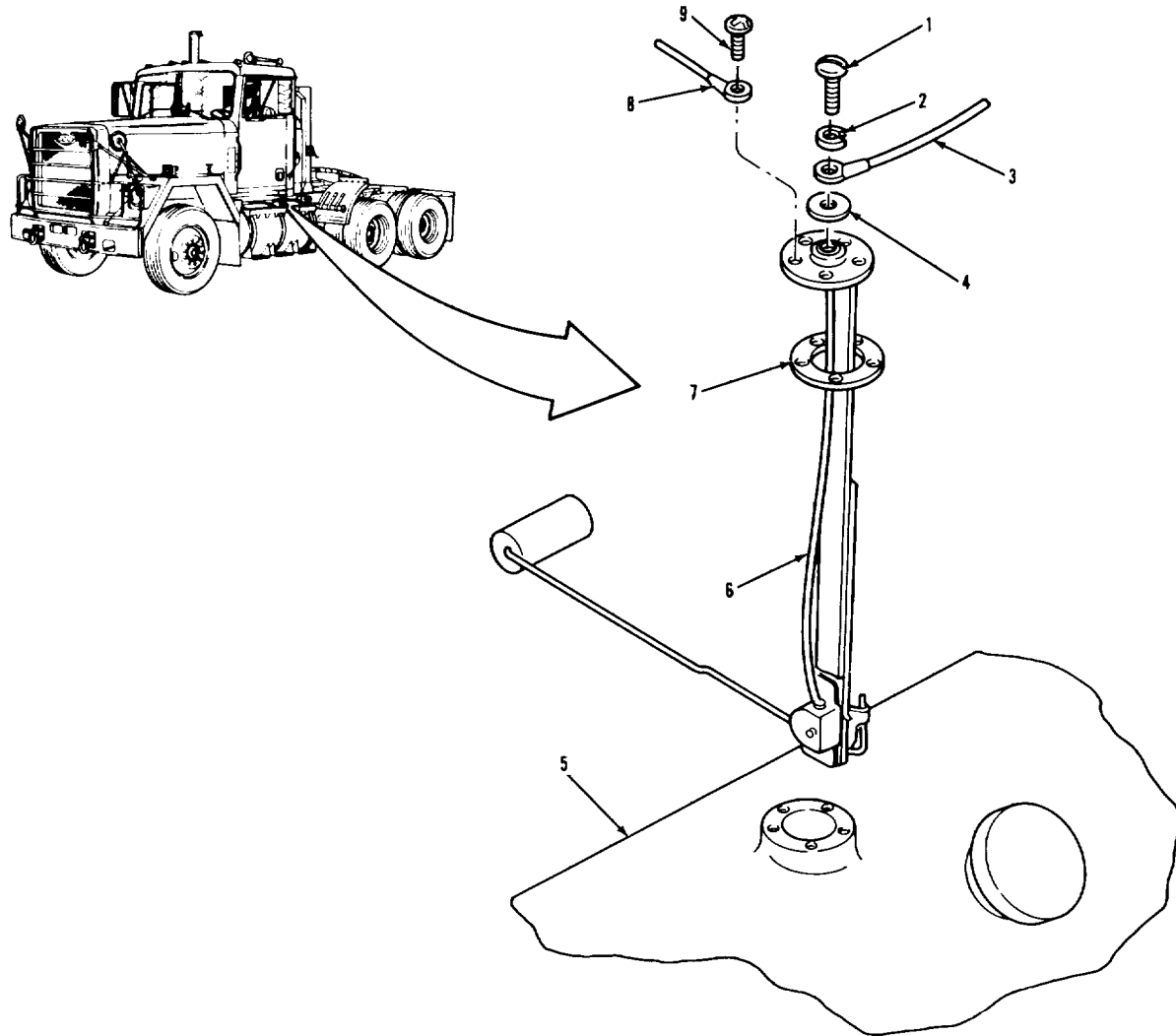

LEGEND:

- 1. SCREW
- 2. LOCKWASHER
- 3. WIRE (74A)
- 4. WASHER
- 5. FUEL TANK

- 6. FUEL LEVEL SENDING UNIT
- 7. GASKET
- 8. WIRE (99)
- 9. SCREW (5)

TA 237282

**ELECTRICAL SYSTEM.**

<b>3-105. FUEL LEVEL SENDING UNIT REPLACEMENT (Continued).</b>		
<b>LOCATION/ITEM</b>	<b>ACTION</b>	<b>REMARKS</b>
<b><u>A. REMOVAL.</u></b>		
1. Screw (1), lock-washer (2), wire (3), and washer (4).	Remove from item (6)	Tag wire (3) for identification.
2. Five screws (9) and wire (8).	Remove from item (6).	
3. Unit (6) and gasket (7).	Remove from item (5)	Discard item (7).
<b><u>B. INSTALLATION.</u></b>		
4. Unit (6) and new gasket (7).	Install in item (5).	
5. Five screws (9)	Secure item (8), item (6), and item (7) to item (5).	
6. Screw (1), lock-washer (2), and washer (4).	Secure item (3) to item (6).	
<p><b>NOTE</b>  <b>Follow-on maintenance action required:</b>  <b>None.</b></p>		
<p><b>3-616</b></p>		



ELECTRICAL SYSTEM.

3-105. FUEL LEVEL SENDING UNIT REPLACEMENT (Continued).

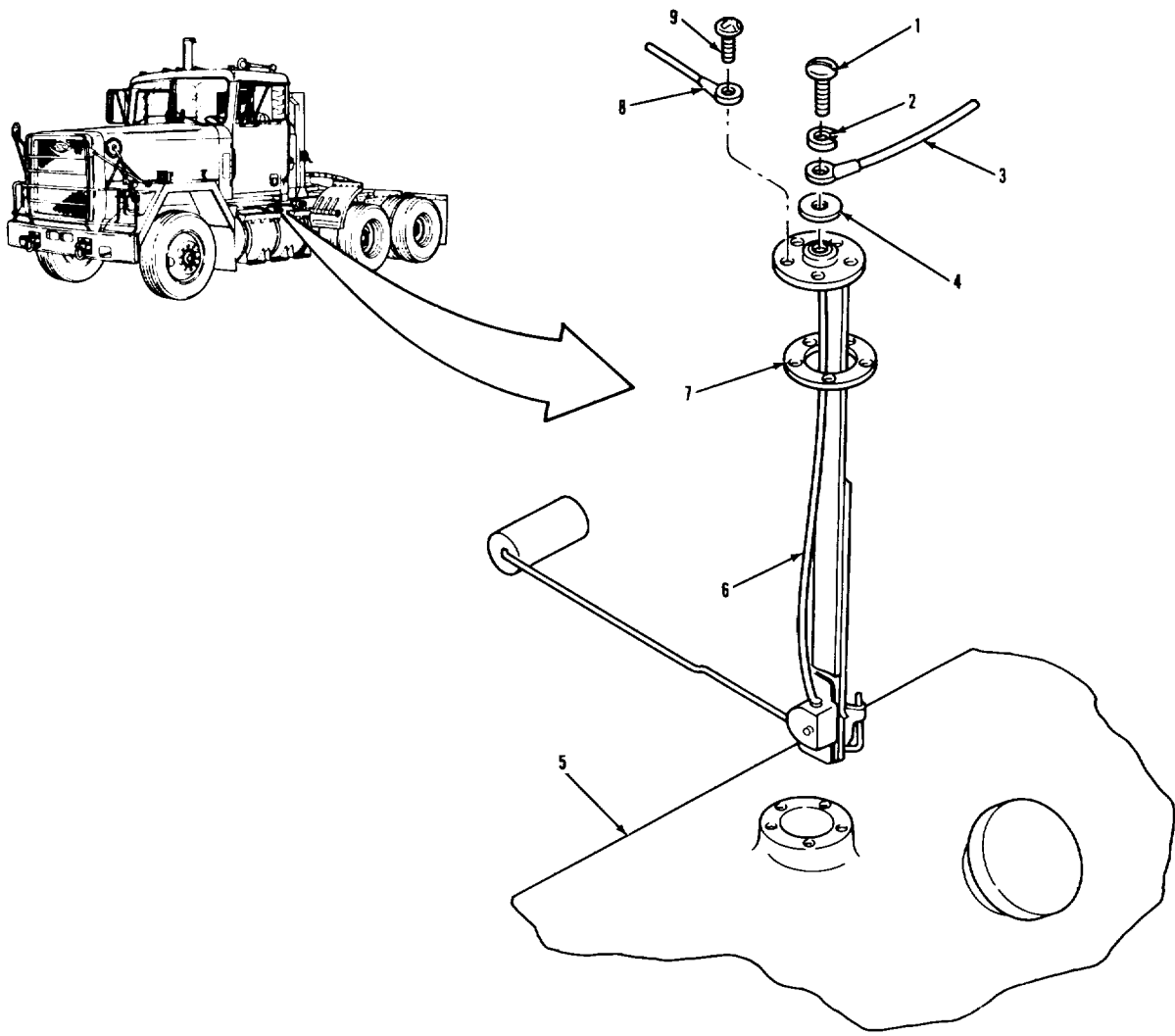

LEGEND:

- 1. SCREW
- 2. LOCKWASHER
- 3. WIRE (74A)
- 4. WASHER
- 5. FUEL TANK

- 6. FUEL LEVEL SENDING UNIT
- 7. GASKET
- 8. WIRE (99)
- 9. SCREW (5)

TA 237283

**ELECTRICAL SYSTEM.**

**3-106. NEUTRAL SAFETY SWITCH AND REVERSE SWITCH REPLACEMENT.**

**THIS TASK COVERS**  
 a. Removal.  
 b. Installation.  
 c. Operational Check.

<u>INITIAL SETUP</u>		
<u>APPLICABLE CONFIGURATIONS</u> All.	<u>EQUIPMENT CONDITION PARAGRAPH</u> TM 9-2320-283-10.	<u>CONDITION DESCRIPTION</u> Transmission shift lever selector in "1" range.
<u>TEST EQUIPMENT</u> None.		
<u>SPECIAL TOOLS</u> None.		
<u>MATERIALS/PARTS (P/N)</u> Cable tie (06383) SST4S.		
<u>PERSONNEL REQUIRED</u> One (MOS-63S).	<u>SPECIAL ENVIRONMENTAL CONDITIONS</u> Vehicle parked on level ground.	
<u>REFERENCES (TM)</u> TM 9-2320-283-10. TM 9-2320-283-20P.	<u>GENERAL SAFETY INSTRUCTIONS</u> Engine off. Park brake set.	
<u>TROUBLESHOOTING REFERENCES</u> Paragraph 2-11.		

ELECTRICAL SYSTEM.

**3-106. NEUTRAL SAFETY SWITCH AND REVERSE SWITCH REPLACEMENT (Continued).**

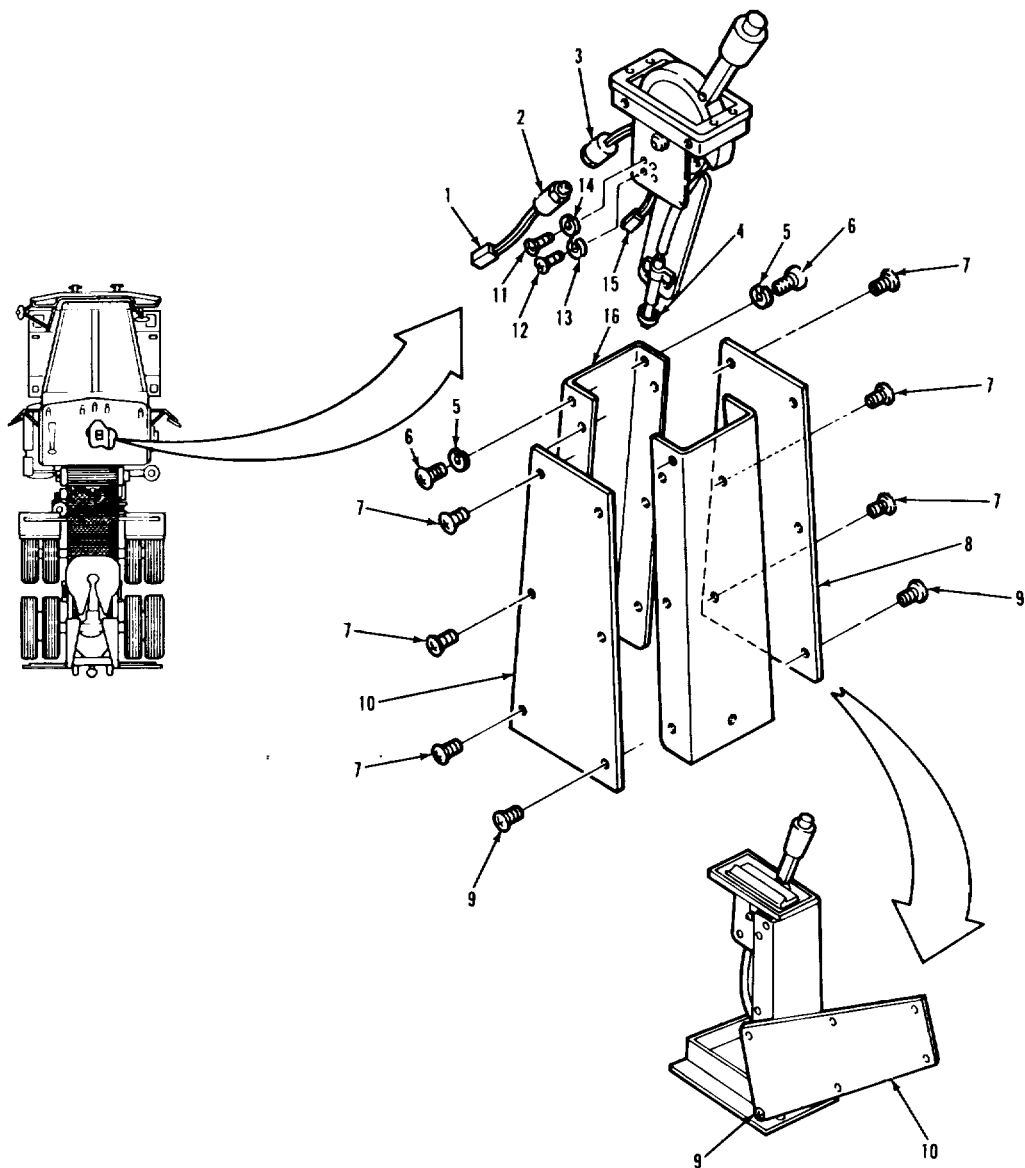

LEGEND:

- |                          |                       |
|--------------------------|-----------------------|
| 1. CONNECTOR             | 9. SCREW (2)          |
| 2. NEUTRAL SAFETY SWITCH | 10. LEFT SIDE BRACKET |
| 3. REVERSE SWITCH        | 11. SCREW (2)         |
| 4. CABLE TIE             | 12. SCREW (2)         |
| 5. LOCKWASHER (2)        | 13. LOCKWASHER (2)    |
| 6. SCREW (2)             | 14. LOCKWASHER (2)    |
| 7. SCREW (9)             | 15. CONNECTOR         |
| 8. RIGHT SIDE BRACKET    | 16. FRONT BRACKET     |

TA 237284

## ELECTRICAL SYSTEM.

3-106. NEUTRAL SAFETY SWITCH AND REVERSE SWITCH REPLACEMENT (Continued).		
LOCATION/ITEM	ACTION	REMARKS
<u>A. REMOVAL.</u>		
1. Two screws (6) and two lock-washers (5).	Remove.	
2. Nine screws (7)	Remove	Remove five items (7) from item (10), three items (7) from item (8), and one item (7) from bottom center of item (16).
3. Two screws (9)	Loosen, but do not remove	Do not remove screws.
4. Front bracket (16).	Remove.	
5. Left side bracket (10)	Rotate clockwise (right) at pivot point of item (9) towards rear of truck.	Exposes left side of shifter mechanism.
6. Cable tie (4)	Note position and remove	Note cables secured by item (4).
7. Two screws (12) and two lock-washers (13).	Remove.	
8. Neutral safety switch (2).	Remove.	
9. Connector (1)	Disconnect	Tag for identification.
10. Two screws (11) and two lock-washers (14).	Remove.	
11. Reverse switch (3).	Remove.	
12. Connector (15)	Disconnect	Tag for identification.

**3-106. NEUTRAL SAFETY SWITCH AND REVERSE SWITCH REPLACEMENT (Continued).**

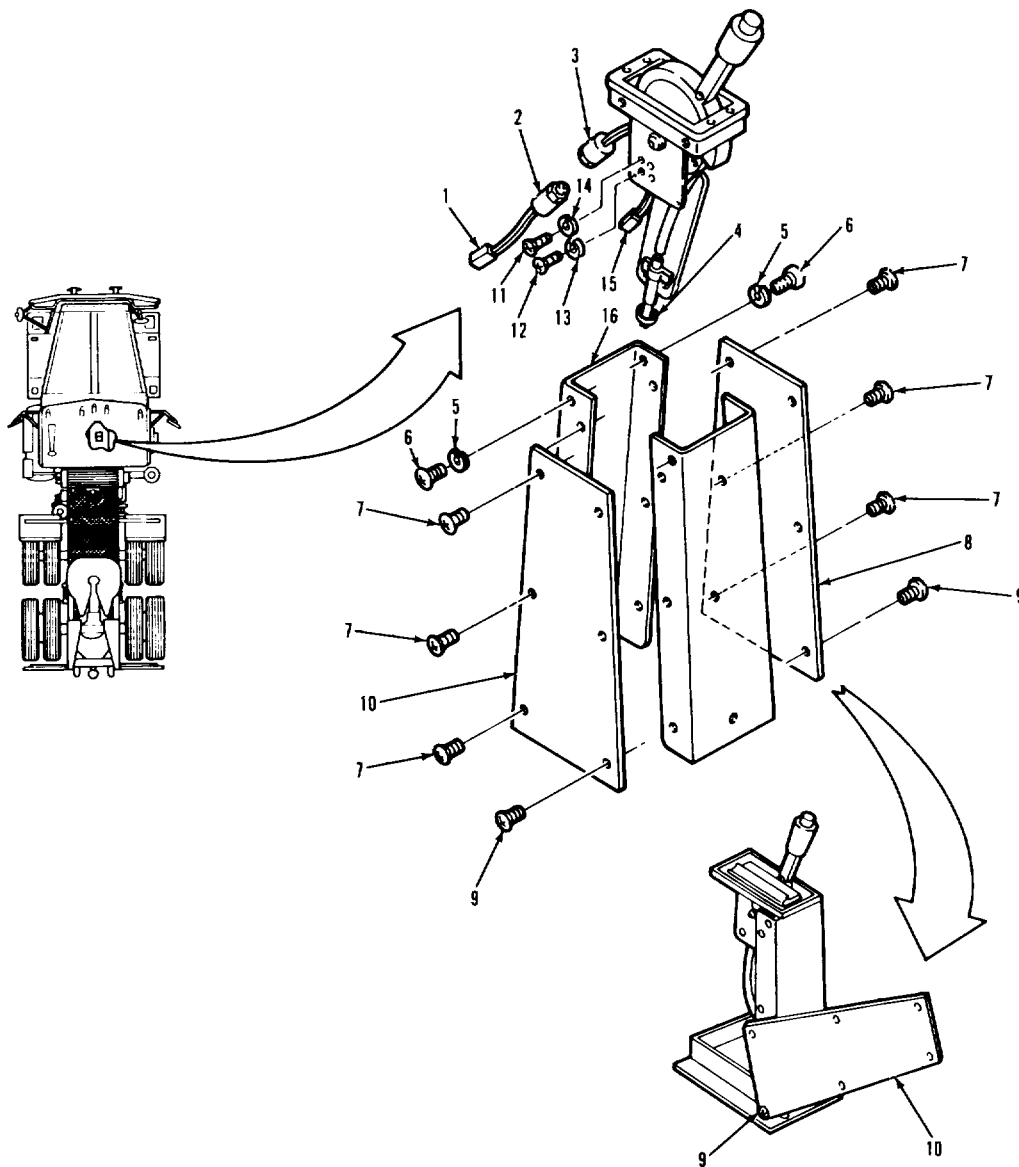

LEGEND:

- |                          |                       |
|--------------------------|-----------------------|
| 1. CONNECTOR             | 9. SCREW (2)          |
| 2. NEUTRAL SAFETY SWITCH | 10. LEFT SIDE BRACKET |
| 3. REVERSE SWITCH        | 11. SCREW (2)         |
| 4. CABLE TIE             | 12. SCREW (2)         |
| 5. LOCKWASHER (2)        | 13. LOCKWASHER (2)    |
| 6. SCREW (2)             | 14. LOCKWASHER (2)    |
| 7. SCREW (9)             | 15. CONNECTOR         |
| 8. RIGHT SIDE BRACKET    | 16. FRONT BRACKET     |

TA 237285

ELECTRICAL SYSTEM.

3-106. NEUTRAL SAFETY SWITCH AND REVERSE SWITCH REPLACEMENT (Continued).		
LOCATION/ITEM	ACTION	REMARKS
<u>B. INSTALLATION.</u>		
13. Connector (15)	Connect	Connect according to identification tag from step 12.
14. Reverse switch (3)	Move into position and aline mounting holes Secure with two items (11) and two items (14).	
15. Connector (1)	Connect	Connect according to identification tag from step 9.
16. Neutral safety switch (2)	Move into position and aline mounting holes two items (12) and two items (13).	Secure with
17. New cable tie (4)	Install. Secure cables noted in step 6	Trim and discard excess length.
18. Left side bracket (10).	Return to normal position.	
19. Frontal bracket (16).	Move into position.	
20. Two screws (6) and two lock-washers (5).	Install and tighten.	
21. Nine screws (7)	Install and tighten.	
22. Two screws (9)	Tighten.	

ELECTRICAL SYSTEM.

3-106. NEUTRAL SAFETY SWITCH AND REVERSE SWITCH REPLACEMENT (Continued).

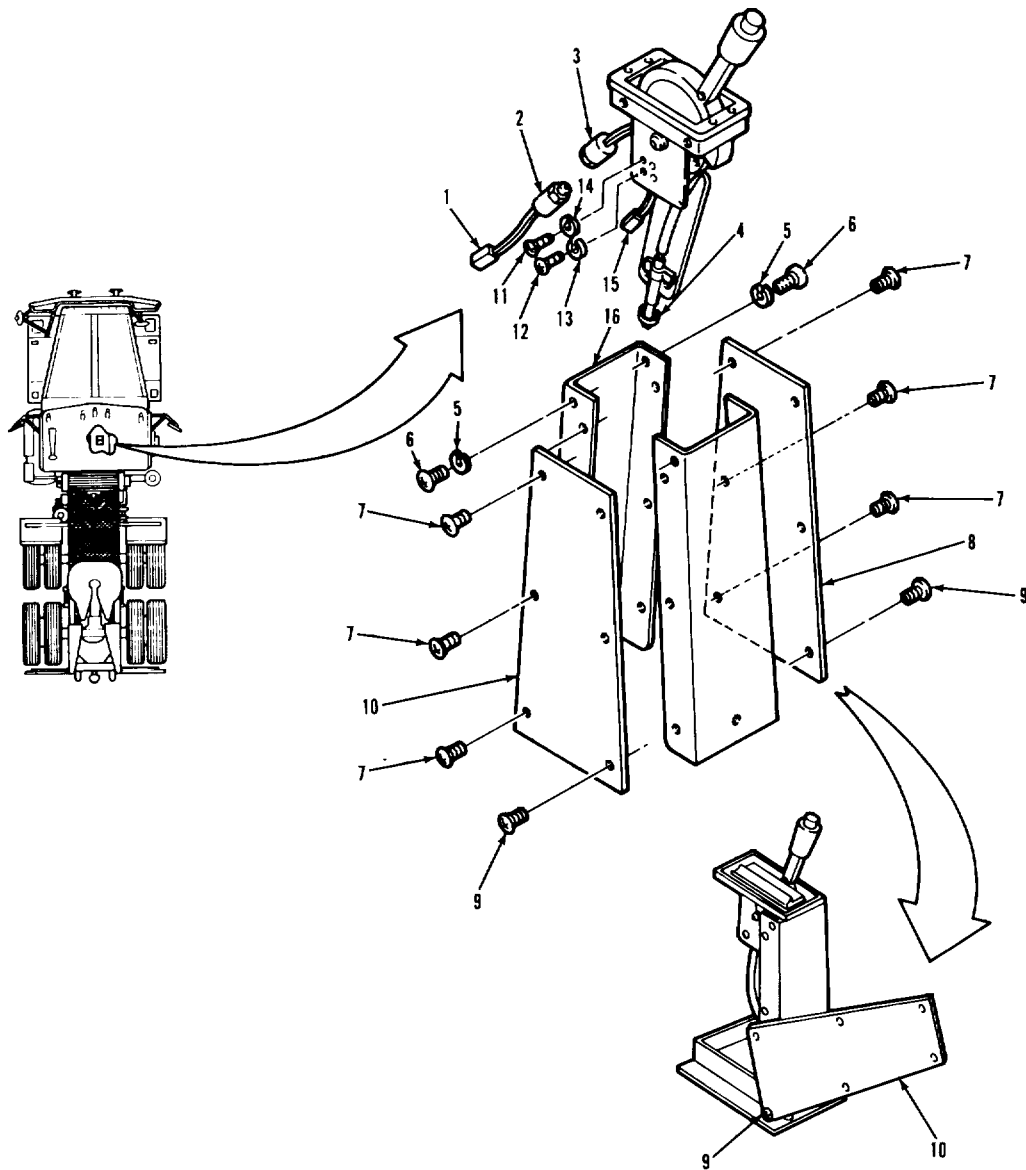

LEGEND:

- |                          |                       |
|--------------------------|-----------------------|
| 1. CONNECTOR             | 9. SCREW (2)          |
| 2. NEUTRAL SAFETY SWITCH | 10. LEFT SIDE BRACKET |
| 3. REVERSE SWITCH        | 11. SCREW (2)         |
| 4. CABLE TIE             | 12. SCREW (2)         |
| 5. LOCKWASHER (2)        | 13. LOCKWASHER (2)    |
| 6. SCREW (2)             | 14. LOCKWASHER (2)    |
| 7. SCREW (9)             | 15. CONNECTOR         |
| 8. RIGHT SIDE BRACKET    | 16. FRONT BRACKET     |

TA 237286

ELECTRICAL SYSTEM.

3-106. NEUTRAL SAFETY SWITCH AND REVERSE SWITCH REPLACEMENT (Continued).		
LOCATION/ITEM	ACTION	REMARKS
<u>C. OPERATIONAL CHECK.</u>		
23. Engine	<ul style="list-style-type: none"> <li>a. Verify that engine starts in neutral and not in any other gear.</li> <li>b. Verify that reverse lamps come on when transmission is shifted to R.</li> <li>c. Shutdown engine.</li> </ul>	Refer to TM 9-2320-283-10.
<p><b>NOTE</b></p> <p><b>Follow-on maintenance action required:</b> <b>None.</b></p>		
3-624		



ELECTRICAL SYSTEM.

3-106. NEUTRAL SAFETY SWITCH AND REVERSE SWITCH REPLACEMENT (Continued).

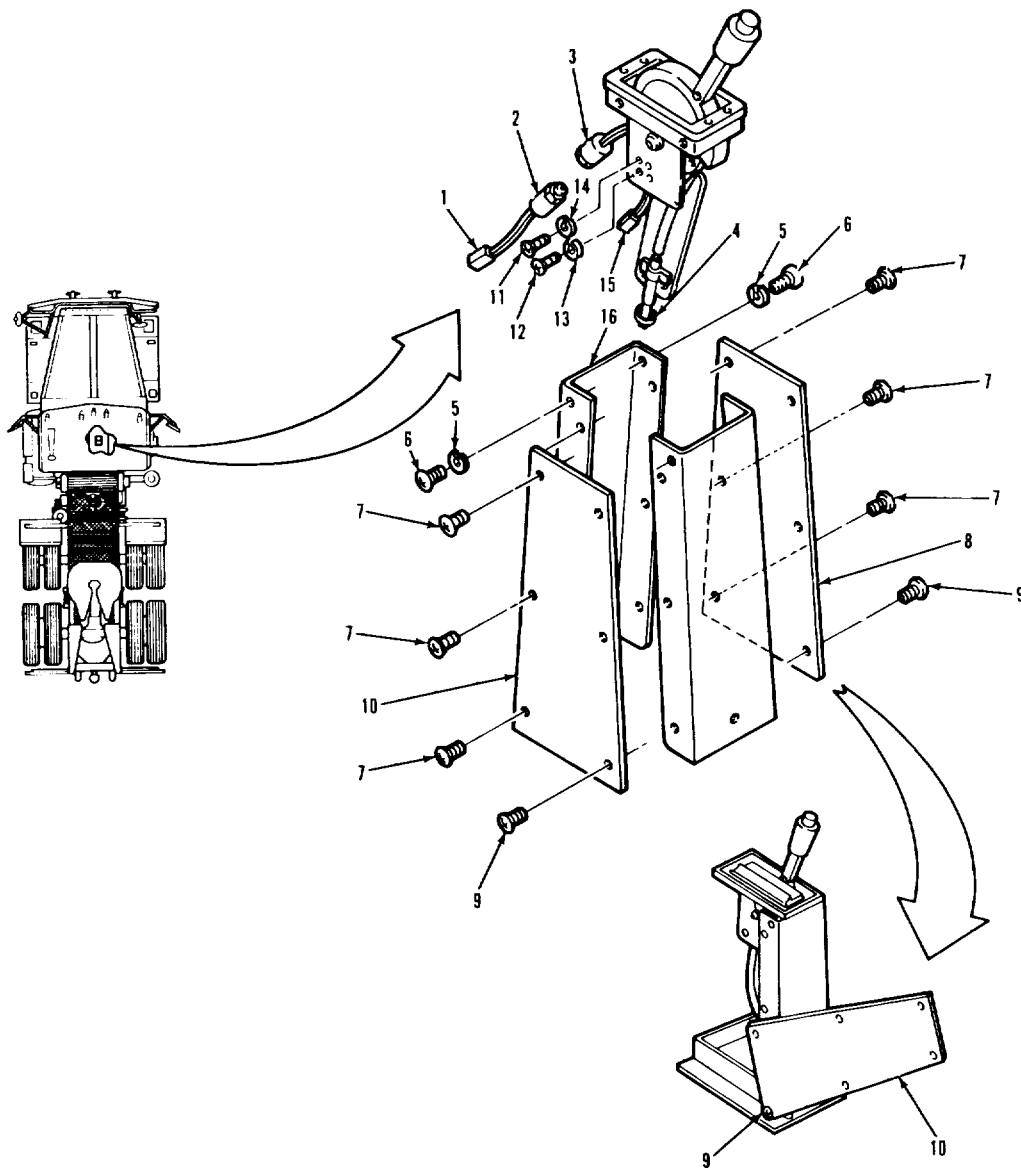

LEGEND:

- 1. CONNECTOR
- 2. NEUTRAL SAFETY SWITCH
- 3. REVERSE SWITCH
- 4. CABLE TIE
- 5. LOCKWASHER (2)
- 6. SCREW (2)
- 7. SCREW (9)
- 8. RIGHT SIDE BRACKET

- 9. SCREW (2)
- 10. LEFT SIDE BRACKET
- 11. SCREW (2)
- 12. SCREW (2)
- 13. LOCKWASHER (2)
- 14. LOCKWASHER (2)
- 15. CONNECTOR
- 16. FRONT BRACKET

TA 237287

**ELECTRICAL SYSTEM.**

**3-107. DIFFERENTIAL LOCK PRESSURE SWITCH REPLACEMENT.**

**THIS TASK COVERS**

- a. Removal.
- b. Installation.
- c. Operational Check.

INITIAL SETUP

APPLICABLE CONFIGURATIONS

All

EQUIPMENT CONDITION

PARAGRAPH

3-120

CONDITION DESCRIPTION

Battery power disconnected.

TEST EQUIPMENT

None.

TM 9-2320-283-10

Air reservoirs drained.

SPECIAL TOOLS

None.

MATERIALS/PARTS (P/N)

Thread sealant, liquid  
Item 33, Appendix C.

PERSONNEL REQUIRED

One (MOS-63S)

SPECIAL ENVIRONMENTAL CONDITIONS

Vehicle parked on level ground.

REFERENCES (TM)

TM 9-2320-283-10  
TM 9-2320-283-20P  
Transmission in neutral.

GENERAL SAFETY INSTRUCTIONS

Engine off.  
Park brake set.

TROUBLESHOOTING REFERENCES

Paragraph 2-11.

ELECTRICAL SYSTEM.

3-107. DIFFERENTIAL LOCK PRESSURE SWITCH REPLACEMENT (Continued).

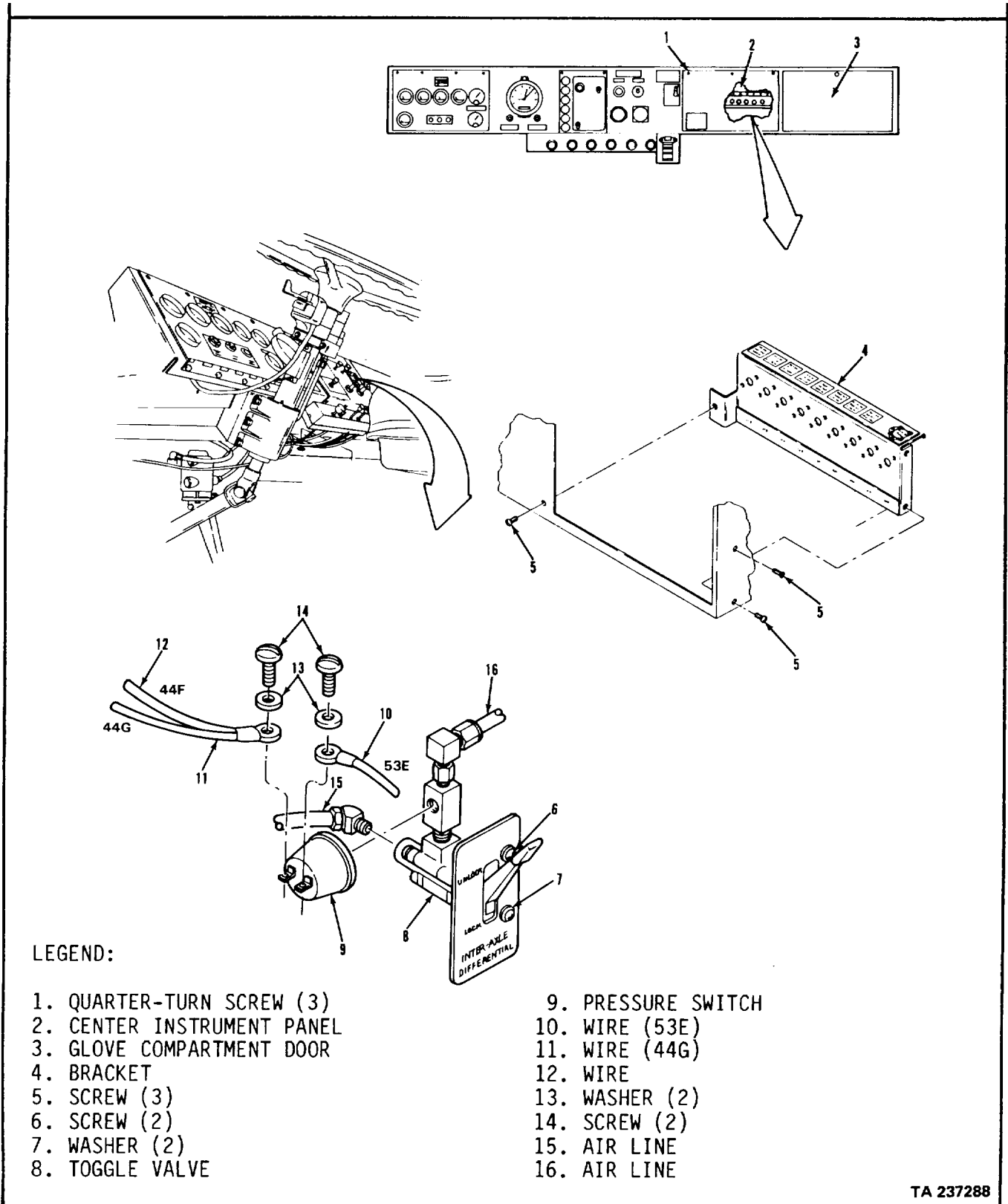

TA 237288

**ELECTRICAL SYSTEM.**

<b>3-107. DIFFERENTIAL LOCK PRESSURE SWITCH REPLACEMENT (Continued).</b>		
<b>LOCATION/ITEM</b>	<b>ACTION</b>	<b>REMARKS</b>
<b>A. REMOVAL.</b>		
1. Three quarter-turn Loosen. screws (1).		
2. Center instrument panel (2).	Lower.	
3. Glove compartment door (3).	Open and lower.	
<p><b><u>WARNING</u></b>  <b>Disconnect batteries before removing circuit breaker bracket Failure to heed warning may result in vehicle electrical system damage and serious personal injury.</b></p>		
3. Three screws (5)	Remove.	
4. Bracket (4)	Remove and position out of way	Remove with circuit breakers and wire harness attached.
5. Two screws (6) and two washers (7).	Remove.	
6. Toggle valve (8)	Remove from back of instrument panel.	
7. Airline (15) and airline (16).	Remove	Tag for identification.
8. Two screws (14) and two washers (13).	Remove.	
9. Wire (10), wire (11), and wire (12)	Remove	Tag for identification. Item (11) and item (12) share a common terminal.
10. Pressure switch (9).	Remove.	

ELECTRICAL SYSTEM.

**3-107. DIFFERENTIAL LOCK PRESSURE SWITCH REPLACEMENT (Continued).**

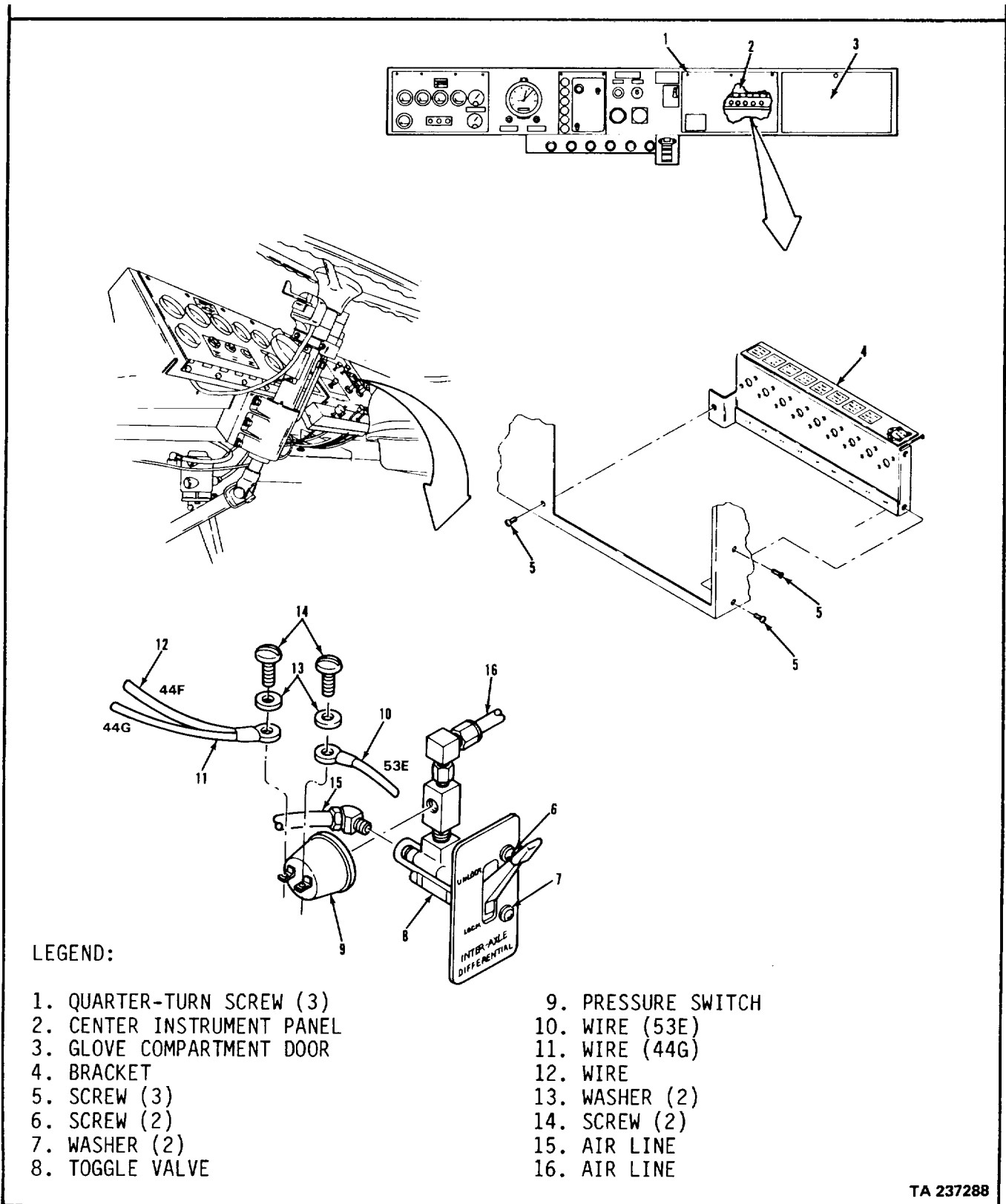

TA 237288

## ELECTRICAL SYSTEM.

3-107. DIFFERENTIAL LOCK PRESSURE SWITCH REPLACEMENT (Continued).		
LOCATION/ITEM	ACTION	REMARKS
<b>B. INSTALLATION.</b>		
11. Pressure switch (9)	Install and tighten	Coat threads with liquid thread sealant.
12. Wire (10), wire (11), and wire (12)	Install using two items (13) and two items (14)	Connect according to identification tag from step 9.
13. Airline (15) and airline (16)	Connect	Connect according to identification tag from step 7.
14. Toggle valve (8)	Move into position behind instrument panel.	
15. Two screws (6) and two washers (7).	Install and tighten.	
16. Bracket (4)	Move into position and secure with three screws (5).	
17. Center instrument panel (2).	Raise into position.	
18. Three quarter-turn screws (1).	Tighten.	
19. Glove compartment door (3).	Raise and close.	
20. Air reservoirs	Close draincocks.	
21. Batteries	Connect.	

ELECTRICAL SYSTEM.

3-107. DIFFERENTIAL LOCK PRESSURE SWITCH REPLACEMENT (Continued).

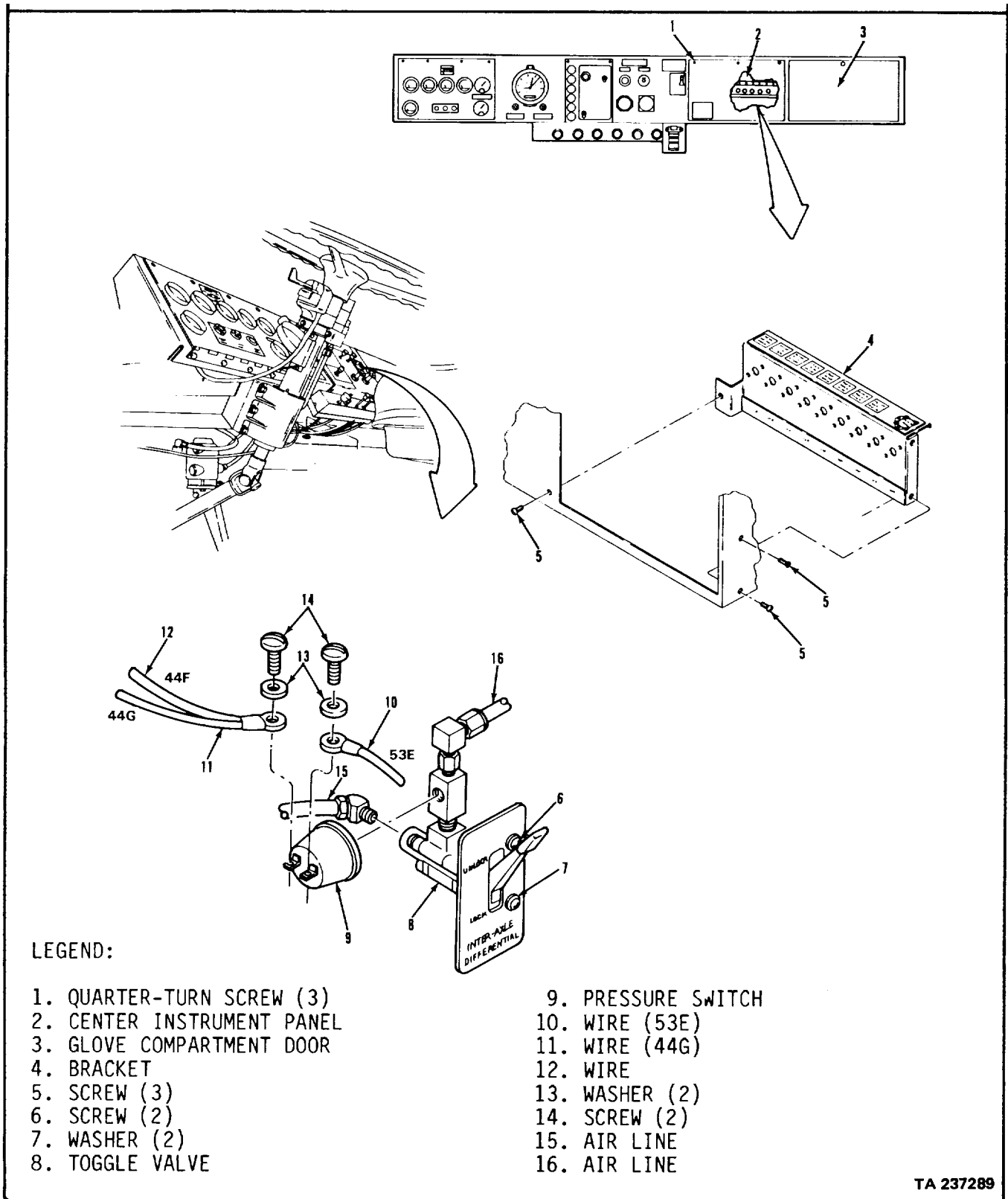

TA 237289

ELECTRICAL SYSTEM.

**3-107. DIFFERENTIAL LOCK PRESSURE SWITCH REPLACEMENT (Continued).**

LOCATION/ITEM	ACTION	REMARKS
---------------	--------	---------

C. OPERATIONAL CHECK.

22. Engine	Start	Refer to TM 9-2320-283-10.
23. Toggle valve (8)	Energize. Set to lock Observe that differential lockout indicator lamp comes on.	Refer to TM 9-2320-283-10.

**NOTE**

**Follow-on maintenance action required:  
None.**



ELECTRICAL SYSTEM.

3-107. DIFFERENTIAL LOCK PRESSURE SWITCH REPLACEMENT (Continued).

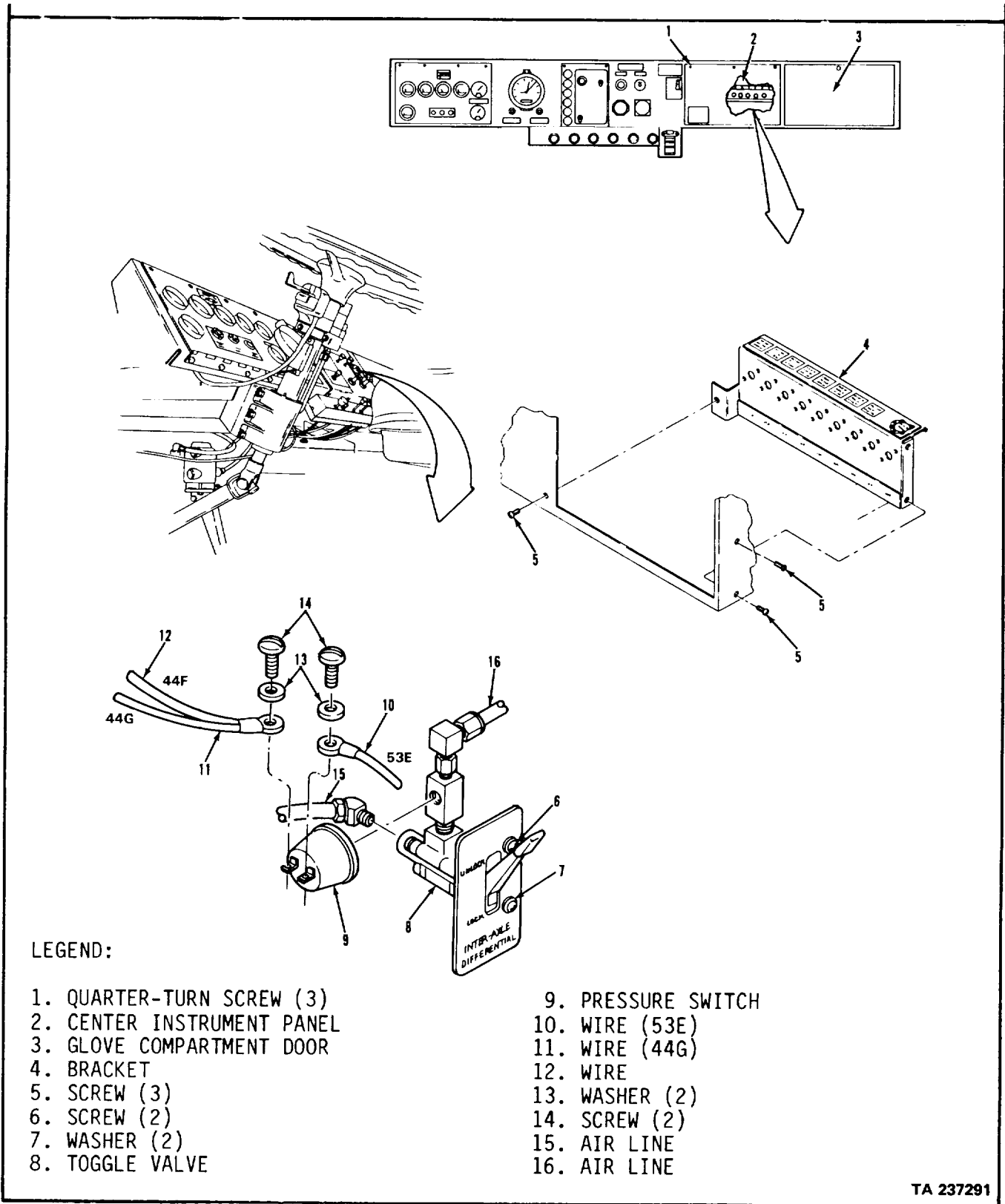

TA 237291

**ELECTRICAL SYSTEM.**

**3-108. PARK BRAKE PRESSURE SWITCH REPLACEMENT.**

**THIS TASK COVERS**

- a. Removal.
- b. Installation.
- c. Operational Check.

INITIAL SETUP

APPLICABLE CONFIGURATIONS

All

EQUIPMENT CONDITION

PARAGRAPH

3-120

CONDITION DESCRIPTION

Battery power disconnected.

TEST EQUIPMENT

None

TM 9-2320-283-10

Air system draincocks open.

SPECIAL TOOLS

None.

MATERIALS/PARTS (P/N)

Thread sealant, liquid  
Item 33, Appendix C.

PERSONNEL REQUIRED

One (MOS-63S)

SPECIAL ENVIRONMENTAL CONDITIONS

None.

REFERENCES (TM)

TM 9-2320-283-10  
TM 9-2320-283-20P

GENERAL SAFETY INSTRUCTIONS

Engine off.  
Park brake set.  
Transmission in neutral.

TROUBLESHOOTING REFERENCES

Paragraph 2-11.

ELECTRICAL SYSTEM.

**3-108. PARK BRAKE PRESSURE SWITCH REPLACEMENT (Continued).**

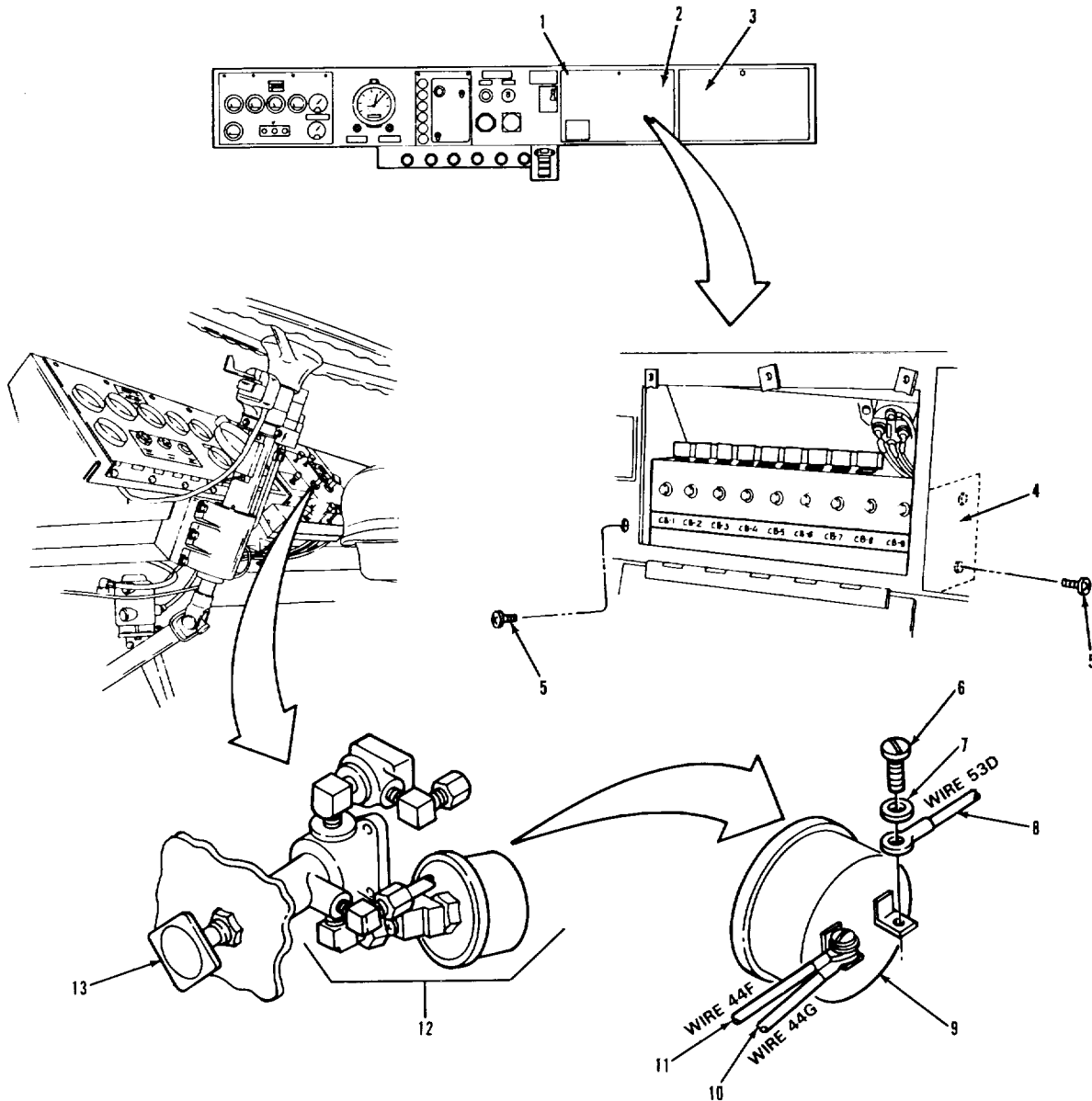

LEGEND:

- |                            |                        |
|----------------------------|------------------------|
| 1. QUARTER-TURN SCREW (3)  | 8. WIRE (53D)          |
| 2. CENTER INSTRUMENT PANEL | 9. PRESSURE SWITCH     |
| 3. GLOVE COMPARTMENT DOOR  | 10. WIRE (44G)         |
| 4. BRACKET                 | 11. WIRE (44F)         |
| 5. SCREW (3)               | 12. VALVE ASSEMBLY     |
| 6. SCREW (2)               | 13. PARK BRAKE CONTROL |
| 7. WASHER (2)              |                        |

TA 237292

**ELECTRICAL SYSTEM.**

<b>3-108. PARK BRAKE PRESSURE SWITCH REPLACEMENT (Continued).</b>		
<b>LOCATION/ITEM</b>	<b>ACTION</b>	<b>REMARKS</b>
<b>A. REMOVAL</b>		
1. Three quarter-turn screws (1).	Loosen.	
2. Center instrument panel (2).	Lower.	
3. Glove compartment door (3).	Open and lower.	
<b>WARNING</b> <b>Disconnect batteries before removing circuit breaker bracket Failure to heed warning may result in vehicle electrical system damage and serious personal injury.</b>		
3. Three screws (5)	Remove.	
4. Bracket (4)	Remove and position out of way	Remove with circuit breakers and wire harness attached.
5. Two screws (6) and two washers (7).	Remove.	
6. Wires (8), (10), and (11)	Remove	Tag for identification. Item (10) and item (11) share a common terminal.
7. Pressure switch (9).	Remove.	
<b>3-636</b>		

ELECTRICAL SYSTEM.

**3-108. PARK BRAKE PRESSURE SWITCH REPLACEMENT (Continued).**

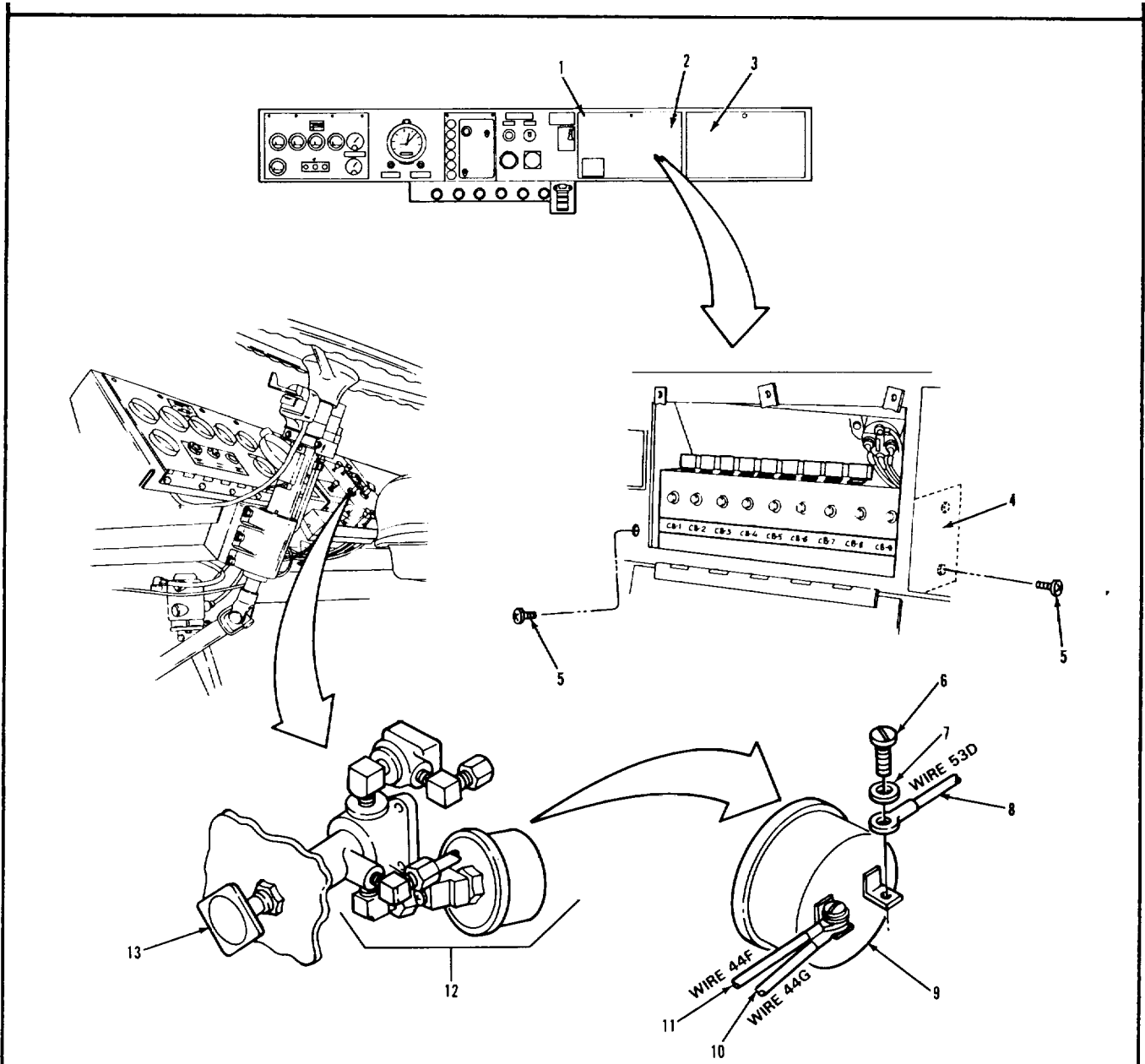

LEGEND:

- 1. QUARTER-TURN SCREW (3)
- 2. CENTER INSTRUMENT PANEL
- 3. GLOVE COMPARTMENT DOOR
- 4. BRACKET
- 5. SCREW (3)
- 6. SCREW (2)
- 7. WASHER (2)

- 8. WIRE (53D)
- 9. PRESSURE SWITCH
- 10. WIRE (44G)
- 11. WIRE (44F)
- 12. VALVE ASSEMBLY
- 13. PARK BRAKE CONTROL

TA 237293

**ELECTRICAL SYSTEM.**

<b>3-108. PARK BRAKE PRESSURE SWITCH REPLACEMENT (Continued).</b>		
<b>LOCATION/ITEM</b>	<b>ACTION</b>	<b>REMARKS</b>
<b><u>B. INSTALLATION. I</u></b>		
8. Pressure switch (9)	Coat threads with liquid thread sealant Install tighten into item (12).	
9. Wires (8), (10), and (11)	Connect using two items (6) and two items (7)	Connect according to identification tag from step 6.
10. Bracket (4)	Move into position and secure with three screws (5).	
11. Center instrument panel (2).	Raise into position.	
12. Three quarter-turn screws (1).	Tighten.	
13. Glove compartment door (3).	Raise and close.	
14. Air reservoirs	Close draincocks.	
15. Batteries	Connect.	
<b><u>C. OPERATIONAL CHECK.</u></b>		
16. Engine	Start	Refer to TM 9-2320-283-10.
17. Park brake control (13)	Pull on indicator lamp comes on	Observe that Refer to TM 9-2320-283-10.
<p><b>NOTE</b>  <b>Follow-on maintenance action required:</b>  <b>None.</b></p>		

ELECTRICAL SYSTEM.

**3-108. PARK BRAKE PRESSURE SWITCH REPLACEMENT (Continued).**

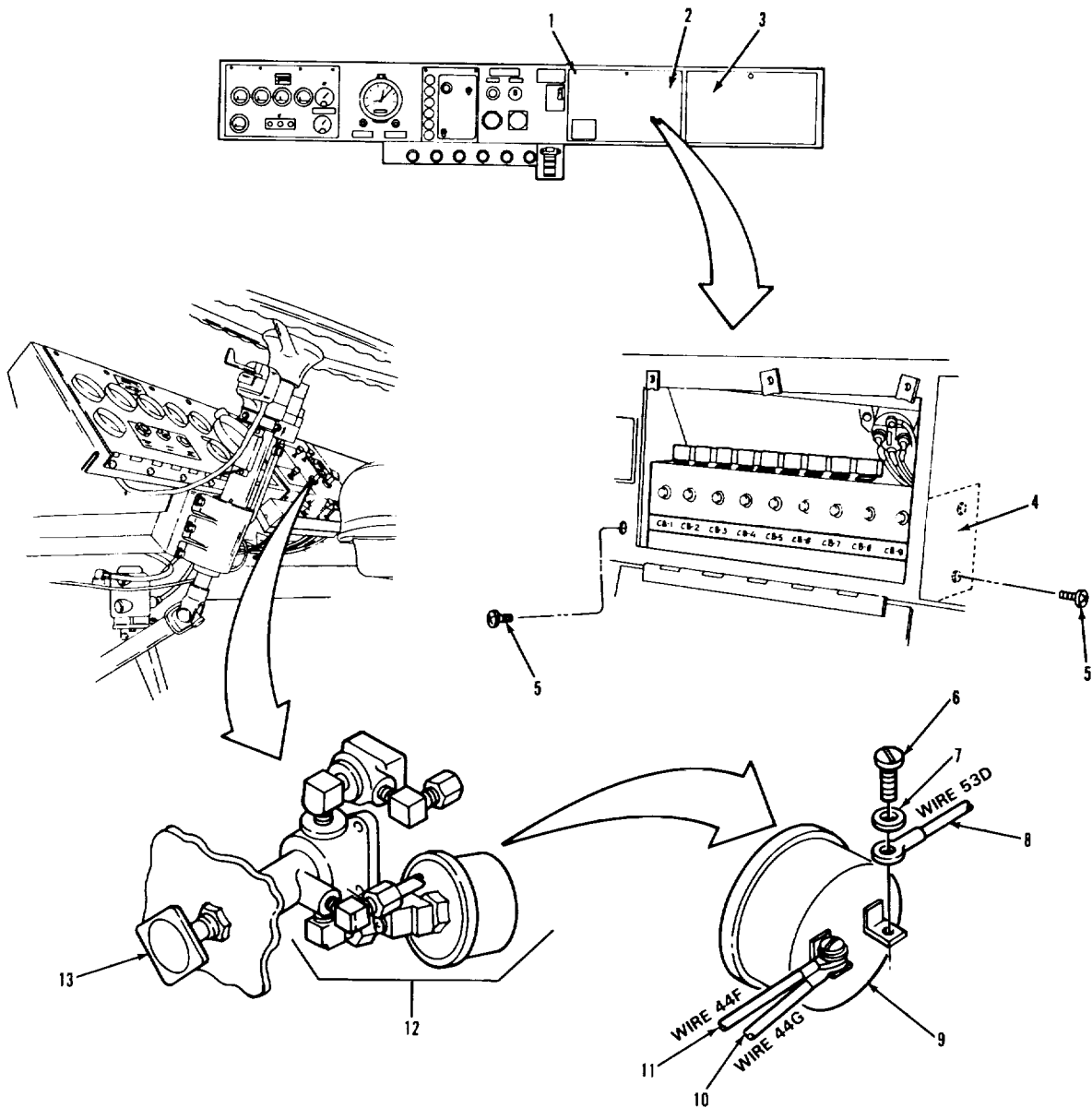

LEGEND:

- |                            |                        |
|----------------------------|------------------------|
| 1. QUARTER-TURN SCREW (3)  | 8. WIRE (53D)          |
| 2. CENTER INSTRUMENT PANEL | 9. PRESSURE SWITCH     |
| 3. GLOVE COMPARTMENT DOOR  | 10. WIRE (44G)         |
| 4. BRACKET                 | 11. WIRE (44F)         |
| 5. SCREW (3)               | 12. VALVE ASSEMBLY     |
| 6. SCREW (2)               | 13. PARK BRAKE CONTROL |
| 7. WASHER (2)              |                        |

TA 237294

**ELECTRICAL SYSTEM.**

**3-109. LOW AIR PRESSURE SWITCH REPLACEMENT.**

**THIS TASK COVERS**

- a. Removal.
- b. Installation.
- c. Installation.

INITIAL SETUP

<u>APPLICABLE CONFIGURATIONS</u> All	<u>EQUIPMENT CONDITION PARAGRAPH</u> TM 9-2320-283-10	<u>CONDITION DESCRIPTION</u> Air system draincocks open.
---	--	---

<u>TEST EQUIPMENT</u> None	3-120	Battery power disconnected.
-------------------------------	-------	-----------------------------

SPECIAL TOOLS  
None.

MATERIALS/PARTS (P/N)  
None.

<u>PERSONNEL REQUIRED</u> One (MOS-63S)	<u>SPECIAL ENVIRONMENTAL CONDITIONS</u> None.
--	--

<u>REFERENCES (TM)</u> TM 9-2320-283-10	<u>GENERAL SAFETY INSTRUCTIONS</u> Engine off. Transmission in neutral. Park brake set.
--	--

TROUBLESHOOTING REFERENCES  
Paragraph 2-11.



ELECTRICAL SYSTEM.

**3-109. LOW AIR PRESSURE SWITCH REPLACEMENT (Continued).**

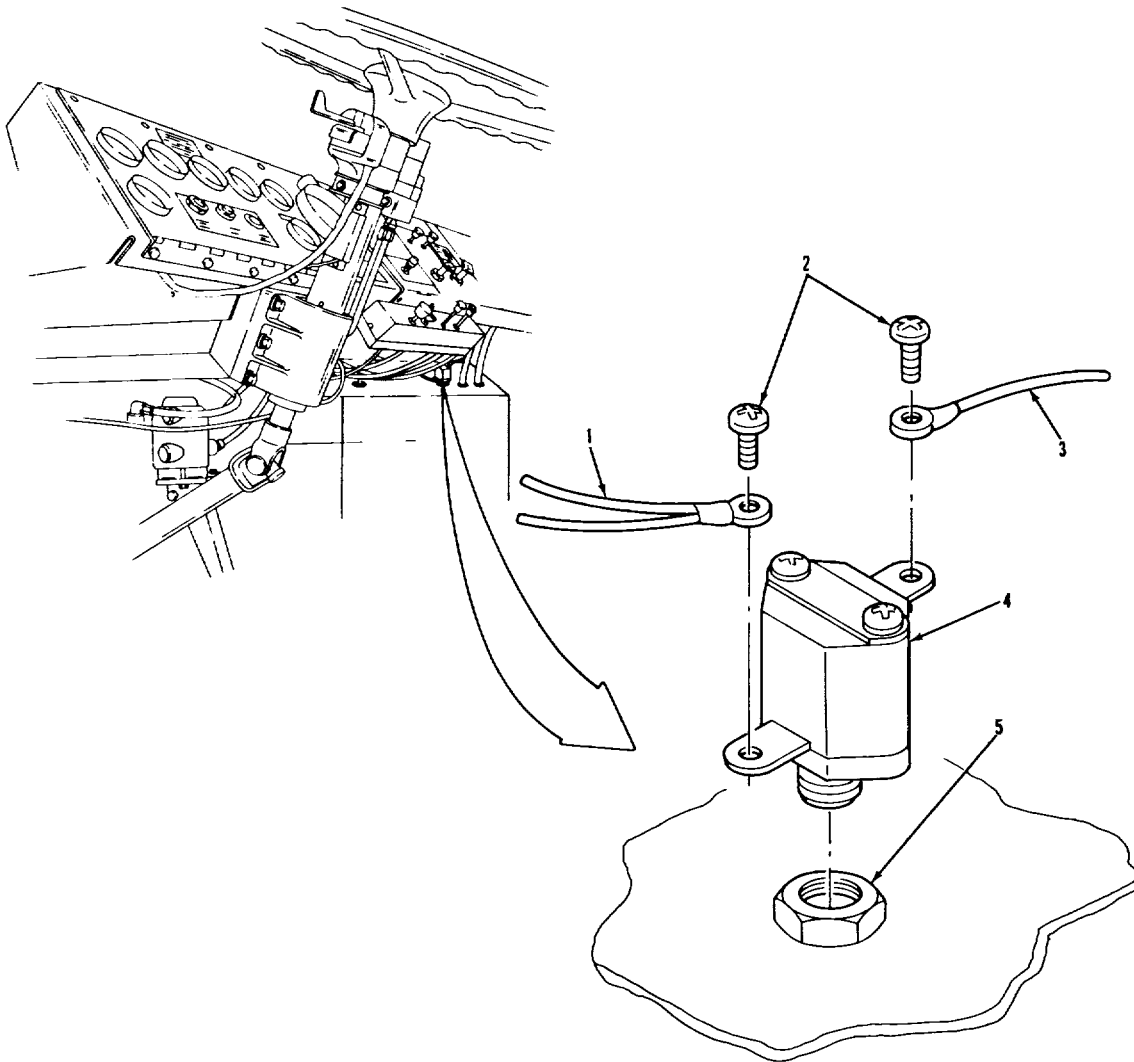

LEGEND:

- 1. WIRES (44E and 44F)
- 2. SCREW (2)
- 3. WIRE (53)
- 4. LOW AIR PRESSURE SWITCH
- 5. BULKHEAD UNION

TA 237295

**ELECTRICAL SYSTEM.**

<b>3-109. LOW AIR PRESSURE SWITCH REPLACEMENT (Continued).</b>		
<b>LOCATION/ITEM</b>	<b>ACTION</b>	<b>REMARKS</b>
<b><u>A. REMOVAL.</u></b>		
1. Two screws (2), wires (1), and wire (3).	Remove from item (4)	Tag wires for identification.
2. Switch (4)	Unscrew from item (5).	
<b><u>B. CLEANING AND INSPECTION.</u></b>		
3. All parts and 3-5.	Clean and inspect	Refer to paragraphs 3-4
<b><u>C. INSTALLATION.</u></b>		
4. Switch (4)	Screw into item (5).	
5. Wires (1) and wire (3)	a. Position on terminals of item (4). b. Secure in place with two items (2).	
<p><b>NOTE</b>  <b>Follow-on maintenance action required:</b>  <b>Connect battery power (para 3-120).</b></p>		

ELECTRICAL SYSTEM.

3-109. LOW AIR PRESSURE SWITCH REPLACEMENT (Continued).

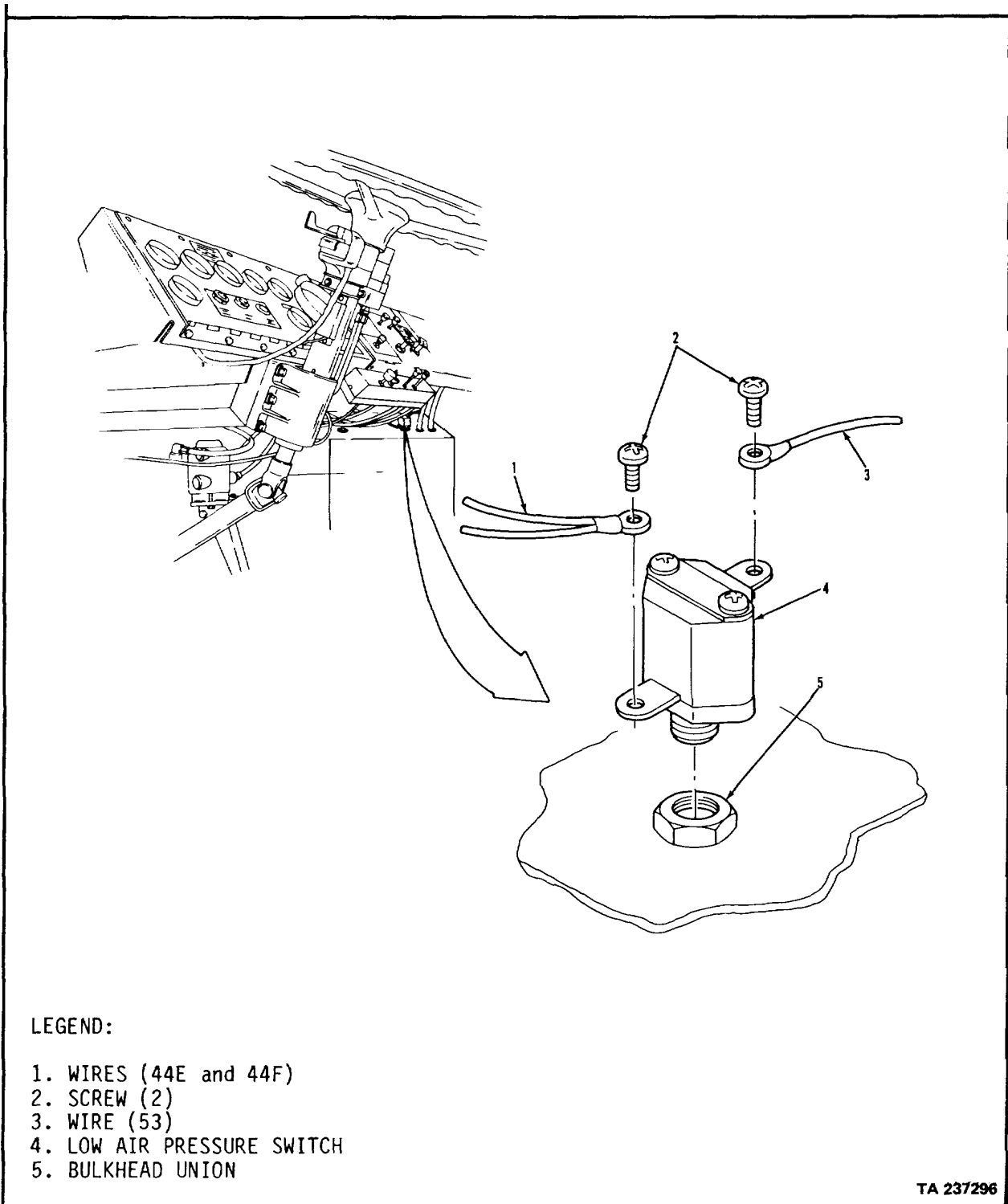

**ELECTRICAL SYSTEM.**

**3-110. LOW AIR PRESSURE BUZZER REPLACEMENT.**

THIS TASK COVERS

- a. Removal.
- b. Cleaning and Inspection.
- c. Installation.

INITIAL SETUP

EQUIPMENT CONDITION

APPLICABLE CONFIGURATIONS

All.

PARAGRAPH

3-120.

CONDITION DESCRIPTION

Battery power disconnected.

TEST EQUIPMENT

None.

SPECIAL TOOLS

None.

MATERIALS/PARTS (P/N)

None.

PERSONNEL REQUIRED

One (MOS-63S).

REFERENCES (TM)

None.

SPECIAL ENVIRONMENTAL CONDITIONS

None.

GENERAL SAFETY INSTRUCTIONS

Engine off.  
Transmission in neutral.  
Park brake set.

TROUBLESHOOTING REFERENCES

Paragraph 2-11.

ELECTRICAL SYSTEM.

**3-110. LOW AIR PRESSURE BUZZER REPLACEMENT (Continued).**

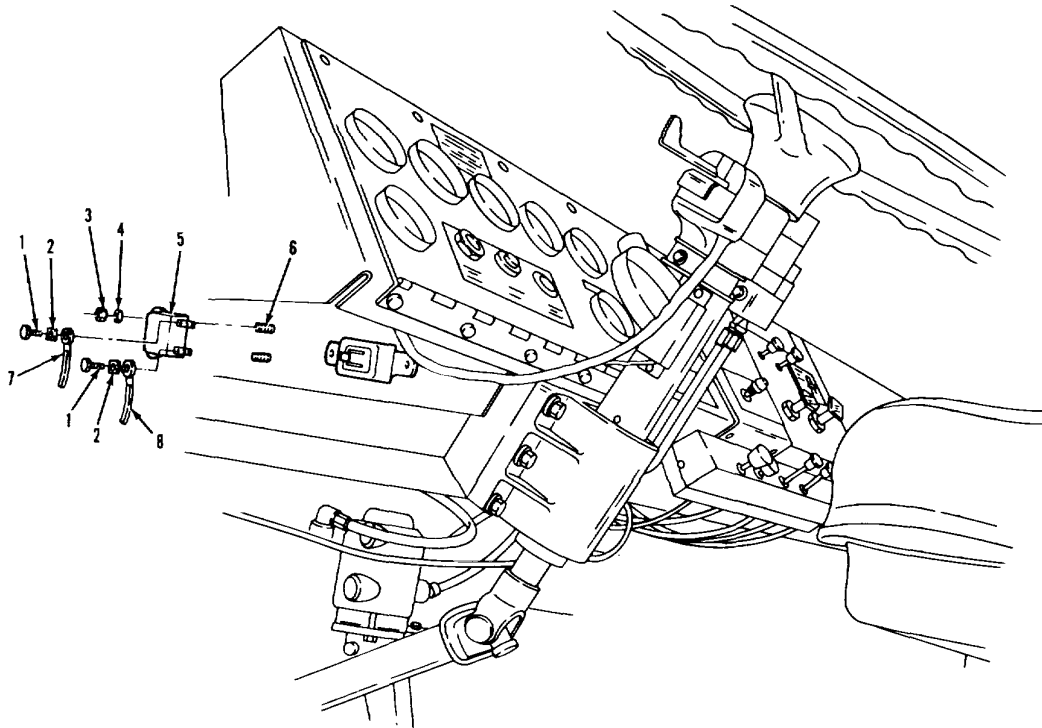

LEGEND:

- 1. SCREW (2)
- 2. WASHER (2)
- 3. NUT (2)
- 4. WASHER (2)

- 5. LOW AIR WARNING BUZZER
- 6. STUD (2)
- 7. WIRE (53A)
- 8. WIRES (99E and 99D)

TA 237297

**ELECTRICAL SYSTEM.**

**3-110. LOW AIR PRESSURE BUZZER REPLACEMENT (Continued).**

LOCATION/ITEM	ACTION	REMARKS
<u>A. REMOVAL.</u>		
1. Two screws (1), washers (2), wire (7), and two wires (8).	Remove from item (5).	Tag wires for identification.
2. Two nuts (3), washers (4), and buzzer (5).	Remove from two items (6).	
<u>B. CLEANING AND INSPECTION.</u>		
3. All parts.	Clean and inspect. and 3-5.	Refer to paragraphs 3-4
<u>C. INSTALLATION.</u>		
4. Buzzer (5). and (4).	a. Position on two items (6). b. Secure with two items (3)	
5. Wire (7) and two wires (8).	a. Position on item (5). b. Secure with two items (1) and (2).	
<p><b>NOTE</b>  <b>Follow-on maintenance action required: Connect battery power (para 3-120).</b></p>		
<p><b>3-646</b></p>		

ELECTRICAL SYSTEM.

**3-110. LOW AIR PRESSURE BUZZER REPLACEMENT (Continued).**

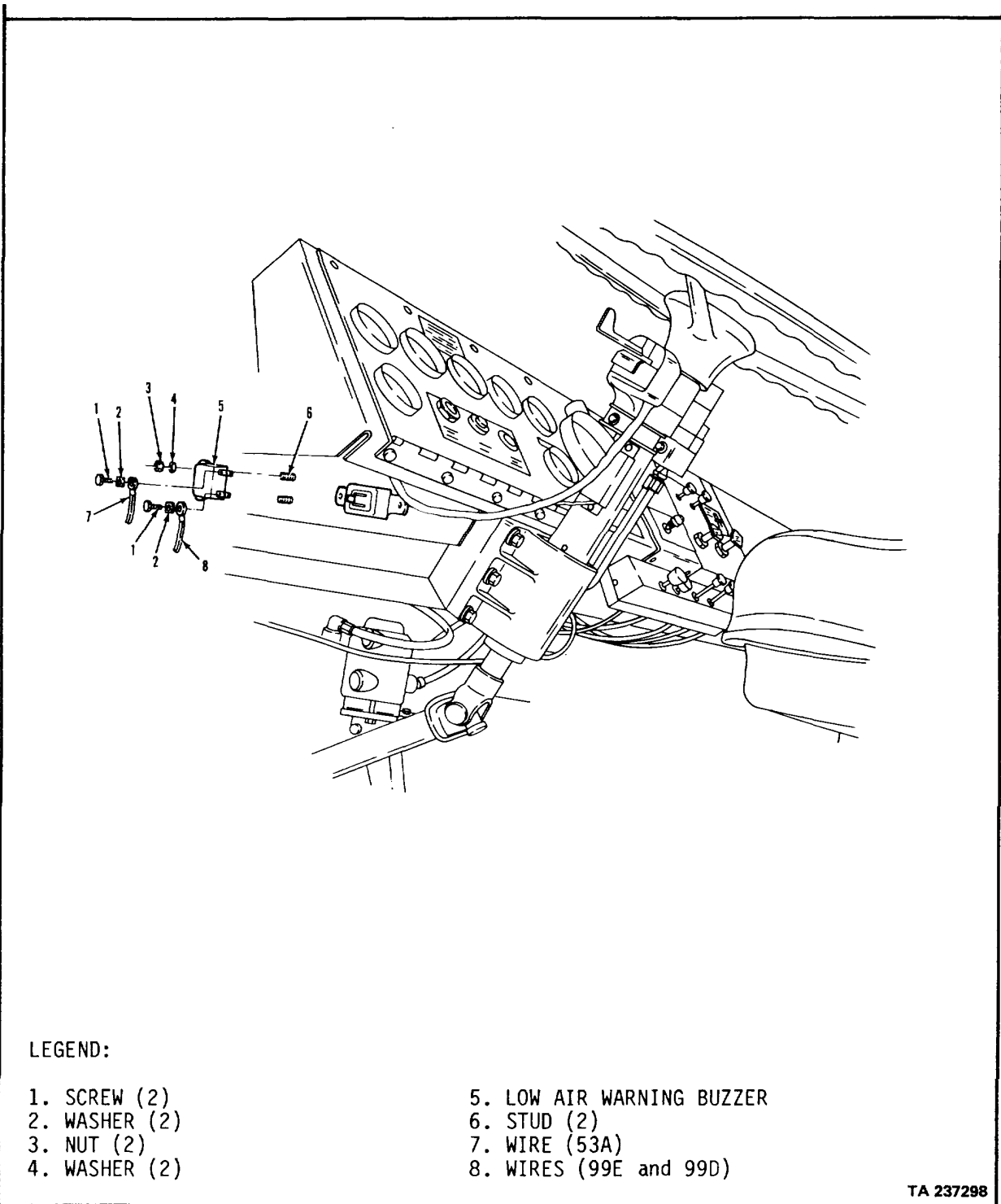

**ELECTRICAL SYSTEM.**

**3-111. TURN SIGNAL FLASHER REPLACEMENT.**

**THIS TASK COVERS**

- a. Removal.
- b. Cleaning and Inspection.
- c. Installation.

INITIAL SETUP

EQUIPMENT CONDITION

APPLICABLE CONFIGURATIONS

All.

PARAGRAPH

None.

CONDITION DESCRIPTION

None.

TEST EQUIPMENT

None.

SPECIAL TOOLS

None.

MATERIALS/PARTS (P/N)

None.

PERSONNEL REQUIRED

One (MOS-63S ).

REFERENCES (TM)

None.

SPECIAL ENVIRONMENTAL CONDITIONS

None.

GENERAL SAFETY INSTRUCTIONS

Engine off.  
Transmission in neutral.  
Park brake set.

TROUBLESHOOTING REFERENCES

Paragraph 2-11.



ELECTRICAL SYSTEM.

3-111. TURN SIGNAL FLASHER REPLACEMENT (Continued).

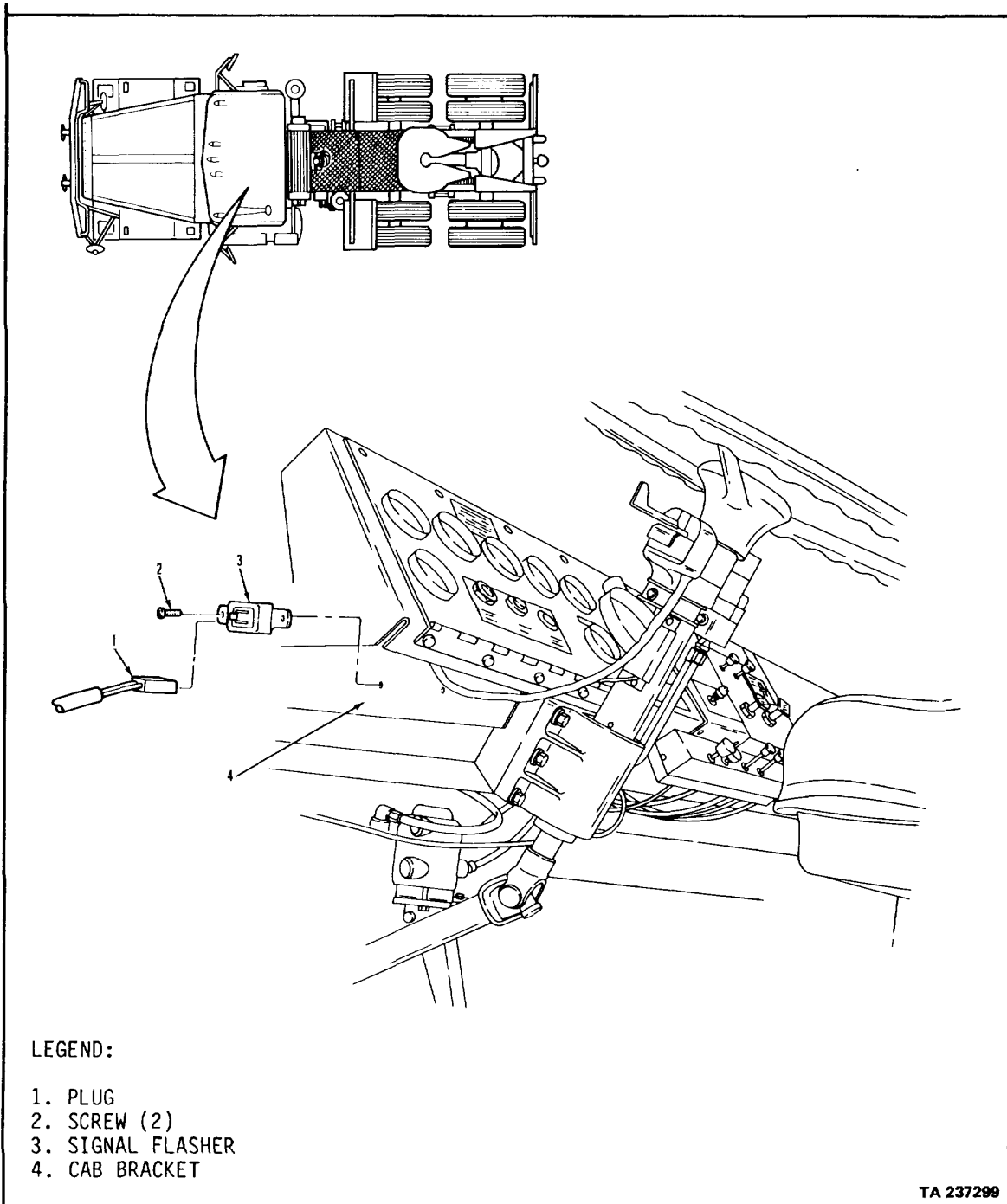

**ELECTRICAL SYSTEM.**

**3-111. TURN SIGNAL FLASHER REPLACEMENT (Continued).**

LOCATION/ITEM	ACTION	REMARKS
<u>A. REMOVAL.</u>		
1. Plug (1).	Pull off of item (3).	
2. Two screws (2) and flasher (3).	Remove from item (4).	
<u>B. CLEANING AND INSPECTION.</u>		
3. All parts.	Clean and inspect.	Refer to paragraphs 3-4 and 3-5.
<u>C. INSTALLATION.</u>		
4. Flasher (3).	a. Position on item (4).	
	b. Secure with two items (2).	
5. Plug (1).	Push onto item (3).	
<p><b>NOTE</b>  <b>Follow-on maintenance action required:</b>  <b>None.</b></p>		
<p><b>3-650</b></p>		

ELECTRICAL SYSTEM.

3-111. TURN SIGNAL FLASHER REPLACEMENT (Continued).

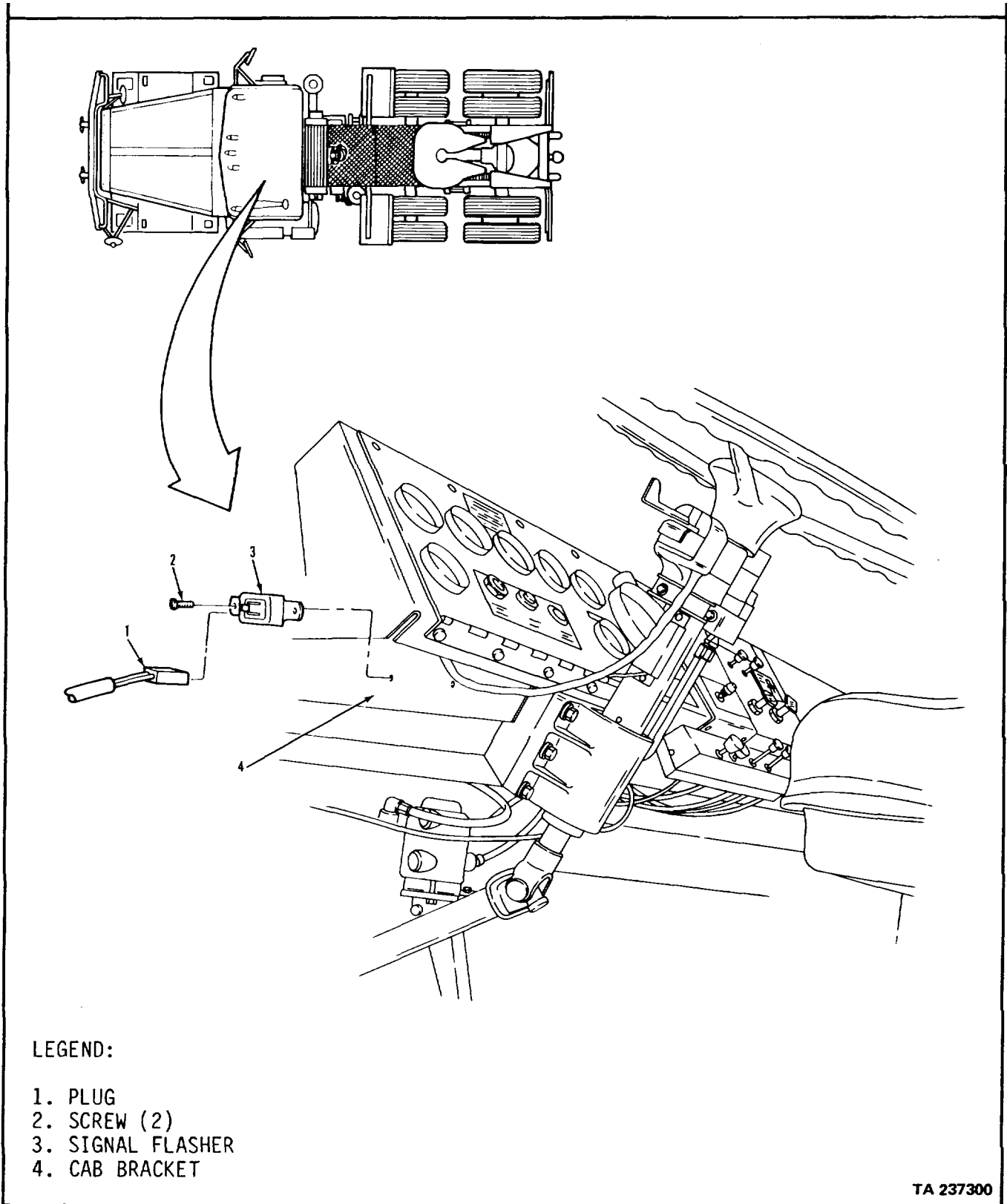

**ELECTRICAL SYSTEM.**

**3-112. INSTRUMENT PANEL RELAYS REPLACEMENT.**

**THIS TASK COVERS**

- a. Removal.
- b. Cleaning and Inspection.
- c. Installation.

INITIAL SETUP

<u>APPLICABLE CONFIGURATIONS</u> All.	<u>EQUIPMENT CONDITION PARAGRAPH</u> 3-120.	<u>CONDITION DESCRIPTION</u> Battery power disconnected.
--	--	---

TEST EQUIPMENT

None.

SPECIAL TOOLS

None.

MATERIALS/PARTS (P/N)

None.

PERSONNEL REQUIRED

One (MOS-63S5).

SPECIAL ENVIRONMENTAL CONDITIONS

None.

REFERENCES (TM)

None.

GENERAL SAFETY INSTRUCTIONS

Engine off.

Transmission in neutral.

Park brake set.

TROUBLESHOOTING REFERENCES

Paragraph 2-11.

ELECTRICAL SYSTEM.

**3-112. INSTRUMENT PANEL RELAYS REPLACEMENT (Continued).**

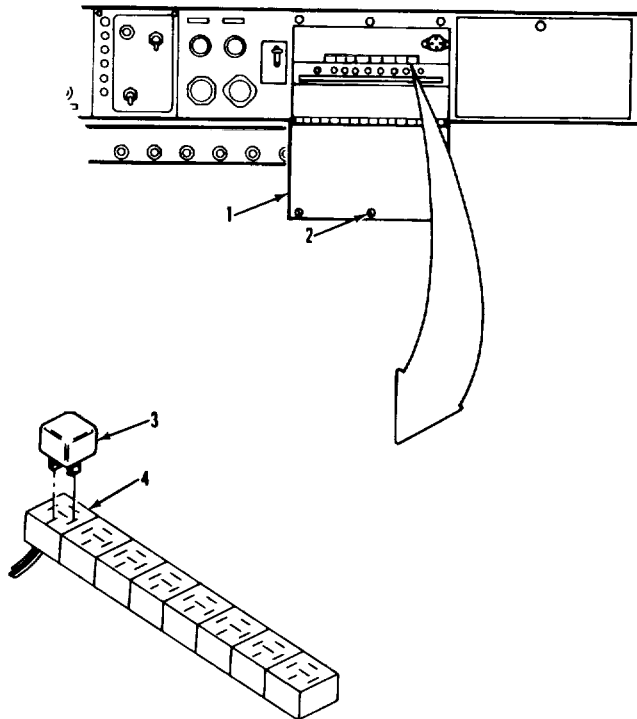

LEGEND:

- 1. INSTRUMENT PANEL CENTER PANEL ASSEMBLY
- 2. QUARTER-TURN SCREW (3)
- 3. RELAY (8)
- 4. RELAY CONNECTOR (8)

TA 237301

ELECTRICAL SYSTEM.

**3-112. INSTRUMENT PANEL RELAYS REPLACEMENT (Continued).**

LOCATION/ITEM	ACTION	REMARKS
<p><b>NOTE</b></p> <p>Use this procedure to replace any one of the eight instrument panel relays.</p>		
<p><u>A. REMOVAL.</u></p>		
1. Panel (1).	Loosen three items (2), and open.	
2. Relay (3).	Using flat tip screwdriver, pry out of item (4).	
<p><u>B. CLEANING AND INSPECTION.</u></p>		
3. All parts.	Clean and inspect.	Refer to paragraphs 3-4 and 3-5. If item (4) is damaged, go to paragraph 3-127 (Wire Harness Repair).
<p><u>C. INSTALLATION</u></p>		
5. Relay (3).	Line up terminals, and push into item (4).	
6. Panel (1).	Close, and secure with three items (2).	
<p><b>NOTE</b></p> <p><b>Follow-on maintenance action required:</b>  <b>Connect battery power (para 3-120).</b></p>		
<p><b>3-654</b></p>		

ELECTRICAL SYSTEM.

**3-112. INSTRUMENT PANEL RELAYS REPLACEMENT (Continued).**

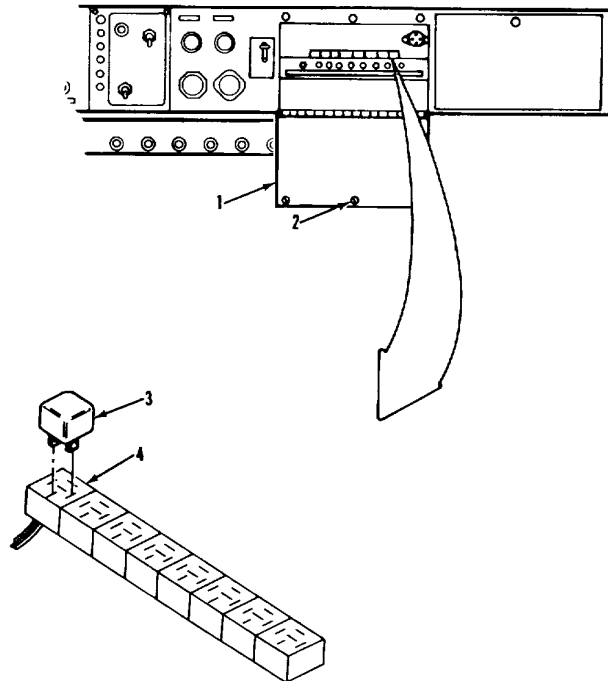

LEGEND:

- 1. INSTRUMENT PANEL CENTER PANEL ASSEMBLY
- 2. QUARTER-TURN SCREW (3)
- 3. RELAY (8)
- 4. RELAY CONNECTOR (8)

TA 237302

**ELECTRICAL SYSTEM.**

**3-113. INSTRUMENT PANEL 24 VOLT RELAY REPLACEMENT.**

THIS TASK COVERS

- a. Removal.
- b. Cleaning and Inspection.
- c. Installation.

INITIAL SETUP

EQUIPMENT CONDITION

APPLICABLE CONFIGURATIONS

All.

PARAGRAPH

3-120.

CONDITION DESCRIPTION

Battery power disconnected.

TEST EQUIPMENT

None.

bracket removed.

SPECIAL TOOLS

None.

MATERIALS/PARTS (P/N)

None.

PERSONNEL REQUIRED

One (MOS-63S).

REFERENCES (TM)

None.

3-114.

breaker mounting

Manual reset circuit

SPECIAL ENVIRONMENTAL CONDITIONS

None.

GENERAL SAFETY INSTRUCTIONS

Engine off.  
Transmission in neutral.  
Park brake set.

TROUBLESHOOTING REFERENCES

Paragraph 2-11.

**3-656**



ELECTRICAL SYSTEM.

3-113. INSTRUMENT PANEL 24 VOLT RELAY REPLACEMENT (Continued).

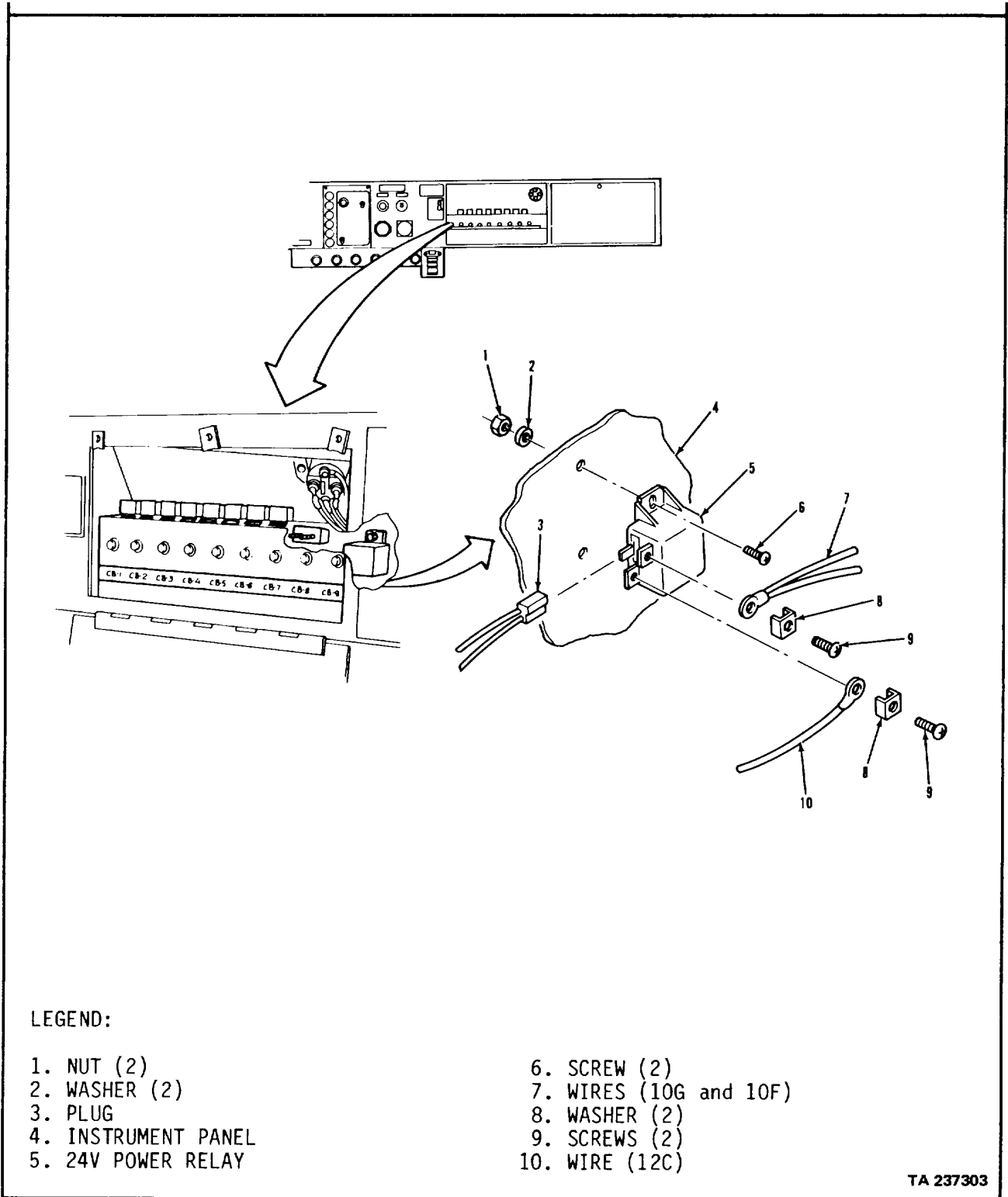

**ELECTRICAL SYSTEM.**

**3-113. INSTRUMENT PANEL 24 VOLT RELAY REPLACEMENT (Continued).**

LOCATION/ITEM	ACTION	REMARKS
<u>A. REMOVAL.</u>		
1. Two screws (9), washer (8), two wires (7), and wire (10).	Remove from item (5).	Tag wires for identification.
2. Plug (3).	Pull out of item (5).	
3. Two nuts (1), washers (2), screws (6), and relay (5).	Remove from item (4).	
<u>B. CLEANING AND INSPECTION.</u>		
4. All parts and 3-5.	Clean and inspect.	Refer to paragraphs 3-4
<u>C. INSTALLATION.</u>		
5. Relay (5).	a. Position on item (4). b. Secure with two items (1),	
6. Plug (3).	Push onto terminals of item	
7. Two wires (7) and wire (10).	a. Position on terminals of item (5). b. Secure with two items (8) and (9).	
<p><b>NOTE</b>  <b>Follow-on maintenance action required: Install manual reset circuit breaker mounting bracket (para 3-114). Connect battery power (para 3-120).</b></p>		
<p><b>3-658</b></p>		

ELECTRICAL SYSTEM.

3-113. INSTRUMENT PANEL 24 VOLT RELAY REPLACEMENT (Continued).

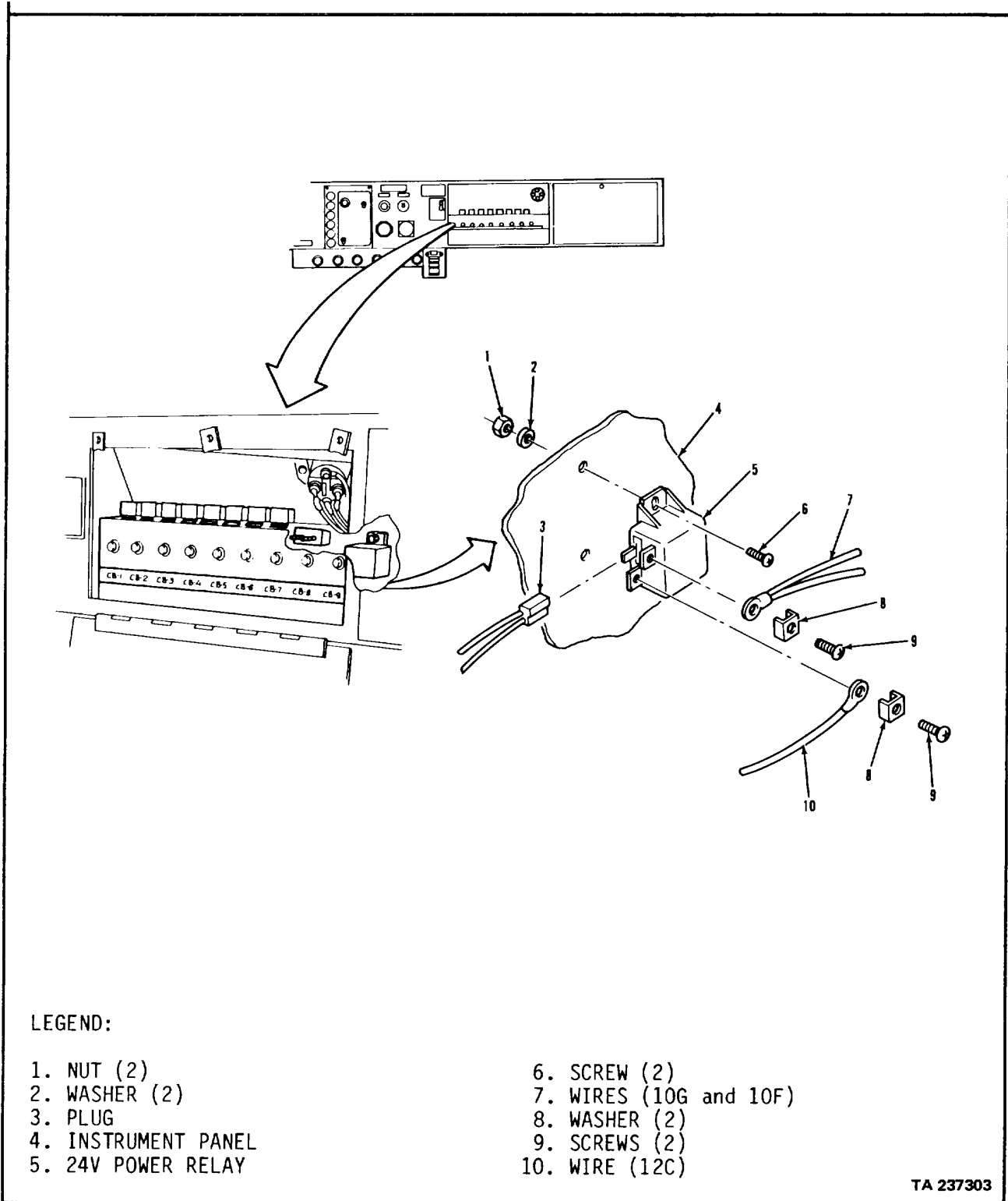

**ELECTRICAL SYSTEM.**

**3-114. MANUAL RESET CIRCUIT BREAKER AND MOUNTING BRACKET REPLACEMENT.**

THIS TASK COVERS

- a. Mounting Bracket Removal.
- b. Circuit Breaker Removal.
- c. Circuit Breaker Installation.
- d. Mounting Bracket Installation.

INITIAL SETUP

APPLICABLE CONFIGURATIONS  
All.

EQUIPMENT CONDITION  
PARAGRAPH  
3-120

CONDITION DESCRIPTION  
Battery power  
disconnected.

TEST EQUIPMENT

None.

SPECIAL TOOLS

None.

MATERIALS/PARTS (P/N)

None.

PERSONNEL REQUIRED

One (MOS-63S).

REFERENCES (TM)

None.

SPECIAL ENVIRONMENTAL CONDITIONS

None.

GENERAL SAFETY INSTRUCTIONS

Engine off.  
Transmission in neutral.  
Park brake set.

TROUBLESHOOTING REFERENCES

Paragraph 2-11.

ELECTRICAL SYSTEM.

**3-114. MANUAL RESET CIRCUIT BREAKER AND MOUNTING BRACKET REPLACEMENT**  
**(Continued).**

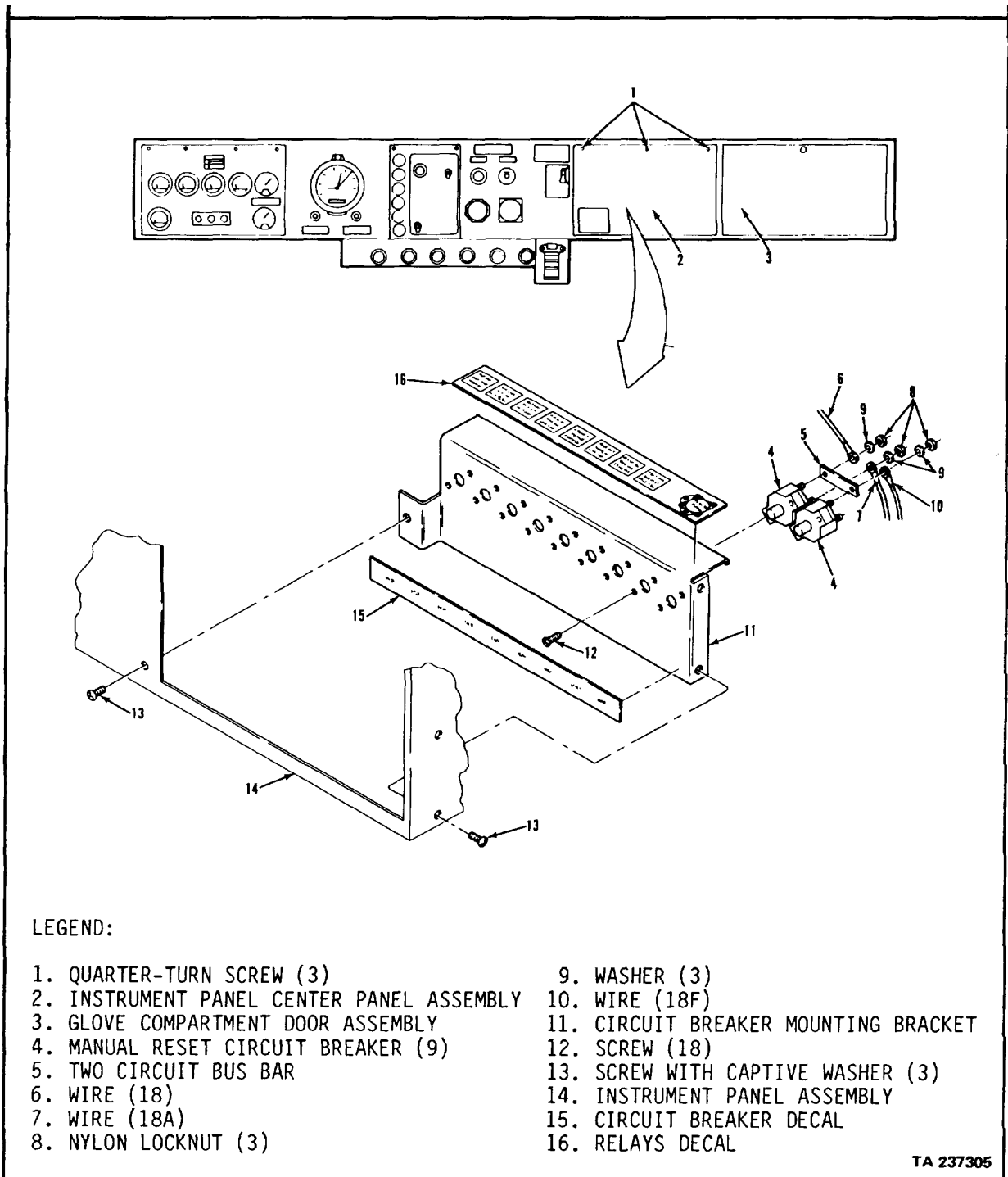

**ELECTRICAL SYSTEM.**

**3-114. MANUAL RESET CIRCUIT BREAKER AND MOUNTING BRACKET REPLACEMENT**

**(Continued).**

LOCATION/ITEM	ACTION	REMARKS
<b>A. MOUNTING BRACKET REMOVAL.</b>		
1. Three screws (1).	Loosen.	
2. Panel assembly (2).	Open.	
3. Door assembly (3).	Open.	
4. Three screws (13).	Remove from item (14) and item (11).	
5. Bracket (11).	Remove from item (14).	
<b>NOTE</b>		
Only do step 6 if you are removing bracket to install a new one.		
6. Eighteen screws (12).	Remove from item (11) and nine items (4).	
<b>B. CIRCUIT BREAKER REMOVAL.</b>		
<b>NOTE</b>		
<b>Replacement of any of the nine circuit breakers is similar. Replacement of CB-8 is shown.</b>		
7. Two locknuts (8), washers (9), bar (5), and wires (6) and (10).	Remove from two items (4).	Tag wires for identification.
8. Locknut (8), washer (9), and wire (7).	Remove from item (4). Remove from item (4).	Tag wire for identification.
9. Two screws (12).	Remove from item (11) and item (4).	
10. Circuit breaker (4).	Remove from item (11).	
<b>3-662</b>		

ELECTRICAL SYSTEM.

**3-114. MANUAL RESET CIRCUIT BREAKER AND MOUNTING BRACKET REPLACEMENT**  
**(Continued).**

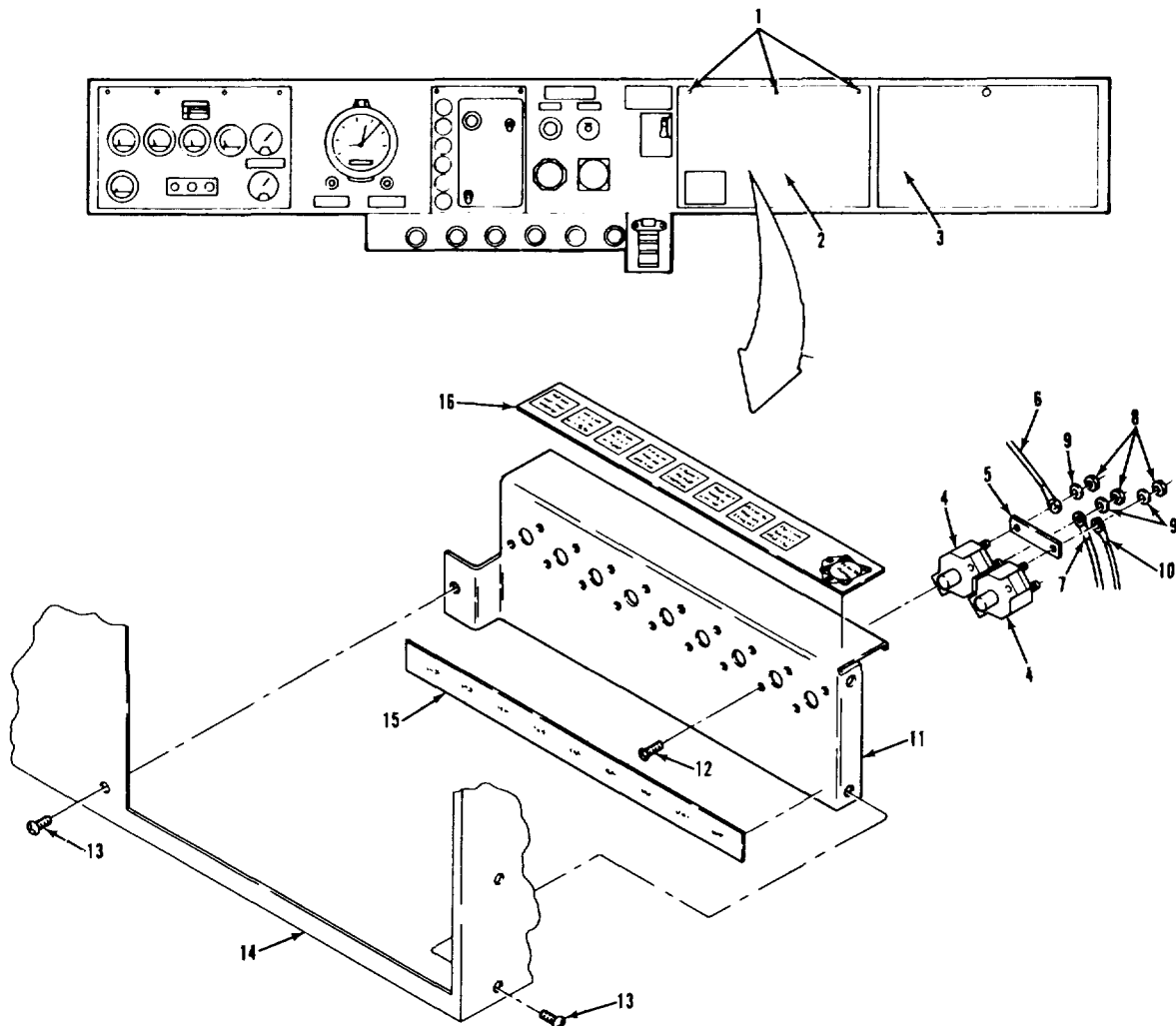

LEGEND:

- |   |                                      |
|---|--------------------------------------|
| 1. QUARTER-TURN SCREW (3)                 | 9. WASHER (3)                        |
| 2. INSTRUMENT PANEL CENTER PANEL ASSEMBLY | 10. WIRE (18F)                       |
| 3. GLOVE COMPARTMENT DOOR ASSEMBLY        | 11. CIRCUIT BREAKER MOUNTING BRACKET |
| 4. MANUAL RESET CIRCUIT BREAKER (9)       | 12. SCREW (18)                       |
| 5. TWO CIRCUIT BUS BAR                    | 13. SCREW WITH CAPTIVE WASHER (3)    |
| 6. WIRE (18)                              | 14. INSTRUMENT PANEL ASSEMBLY        |
| 7. WIRE (18A)                             | 15. CIRCUIT BREAKER DECAL            |
| 8. NYLON LOCKNUT (3)                      | 16. RELAYS DECAL                     |

TA 237306

**ELECTRICAL SYSTEM.**

**3-114. MANUAL RESET CIRCUIT BREAKER AND MOUNTING BRACKET REPLACEMENT**

**(Continued).**

LOCATION/ITEM	ACTION	REMARKS
<u>C. CIRCUIT BREAKER INSTALLATION.</u>		
11. Circuit breaker (4).	Install in item (11).	
12. Two screws (12).	Secure item (4) to item (11).	
13. Locknut (8) and washer (9).	Secure item (7) to item (4).	
14. Two locknuts (8) and washers (9):	Secure item (5), item (6), and item (10) to two items	
<u>D. MOUNTING BRACKET INSTALLATION</u>		
<b>NOTE</b>		
<b>Only do step 15 if you are installing a new bracket.</b>		
15. Decal (16) and decal (15).	Install on item (11).	
16. Eighteen screws (12).	Secure nine items (4) to item (11).	
17. Bracket (11).	Put in place in item (14).	
18. Three screws (13).	Secure item (11) to item (14).	
19. Door assembly (3).	Close.	
20. Panel assembly (2).	Close.	
21. Three screws (1). Tighten.		
<b>NOTE</b>		
<b>Follow-on maintenance action required: Connect battery power (para 3-120).</b>		
<b>3-664</b>		



ELECTRICAL SYSTEM.

**3-114. MANUAL RESET CIRCUIT BREAKER AND MOUNTING BRACKET REPLACEMENT**  
**(Continued).**

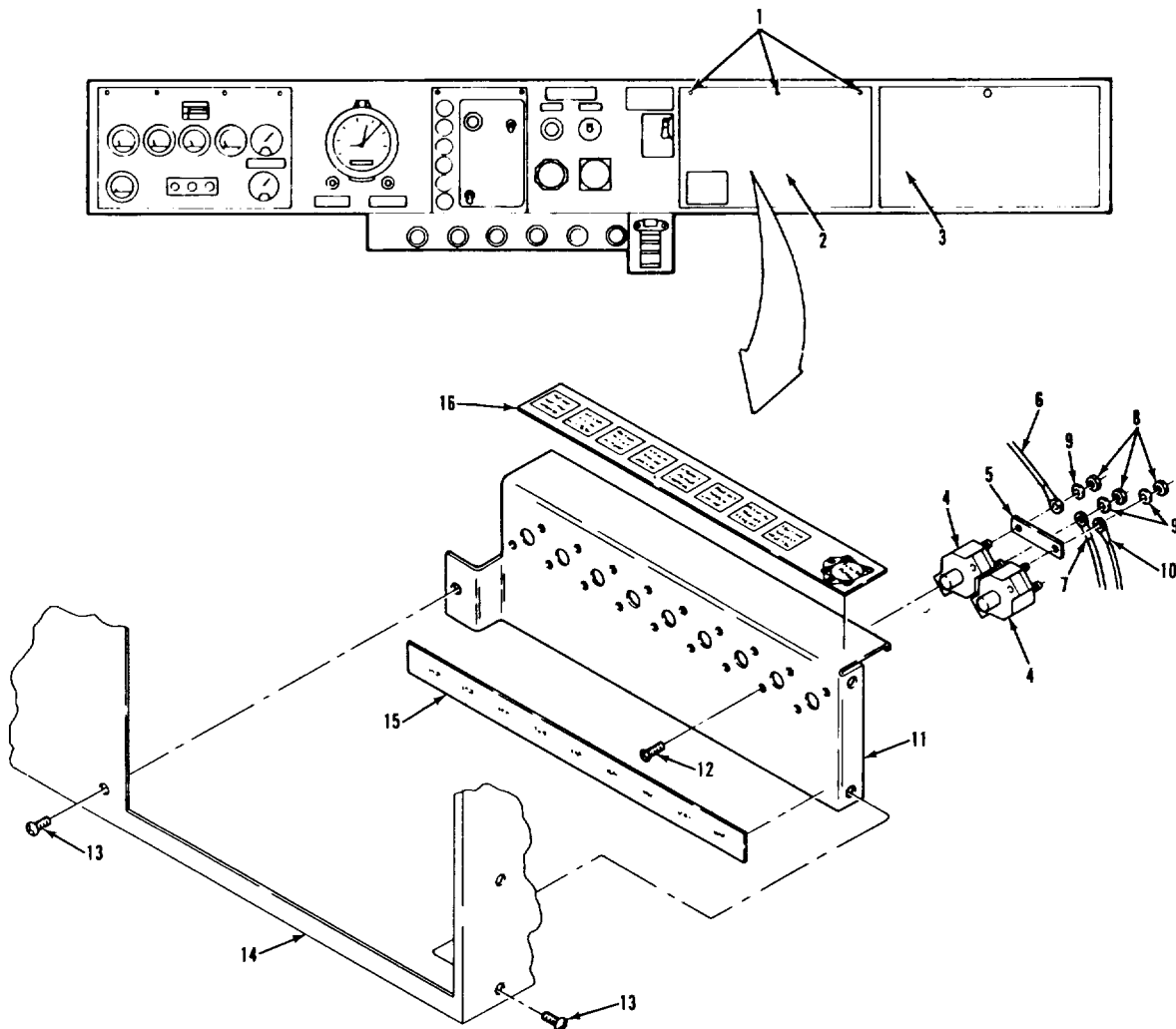

LEGEND:

- |   |                                      |
|---|--------------------------------------|
| 1. QUARTER-TURN SCREW (3)                 | 9. WASHER (3)                        |
| 2. INSTRUMENT PANEL CENTER PANEL ASSEMBLY | 10. WIRE (18F)                       |
| 3. GLOVE COMPARTMENT DOOR ASSEMBLY        | 11. CIRCUIT BREAKER MOUNTING BRACKET |
| 4. MANUAL RESET CIRCUIT BREAKER (9)       | 12. SCREW (18)                       |
| 5. TWO CIRCUIT BUS BAR                    | 13. SCREW WITH CAPTIVE WASHER (3)    |
| 6. WIRE (18)                              | 14. INSTRUMENT PANEL ASSEMBLY        |
| 7. WIRE (18A)                             | 15. CIRCUIT BREAKER DECAL            |
| 8. NYLON LOCKNUT (3)                      | 16. RELAYS DECAL                     |

TA 237307

**ELECTRICAL SYSTEM.**

**3-115. STARTER RELAY REPLACEMENT.**

THIS TASK COVERS

- a. Removal.
- b. Installation.

INITIAL SETUP

APPLICABLE CONFIGURATIONS

All.

EQUIPMENT CONDITION

PARAGRAPH

3-120.

CONDITION DESCRIPTION

Battery power dis-  
connected.

TEST EQUIPMENT

None.

SPECIAL TOOLS

None.

MATERIALS/PARTS (P/N)

None.

PERSONNEL REQUIRED

One (MOS-63S ).

REFERENCES (TM)

None.

SPECIAL ENVIRONMENTAL CONDITIONS

None.

GENERAL SAFETY INSTRUCTIONS

Engine off.  
Transmission in neutral.  
Park brake set.

TROUBLESHOOTING REFERENCES

Paragraph 2-11.

**3-666**

ELECTRICAL SYSTEM.

3-115. STARTER RELAY REPLACEMENT (Continued).

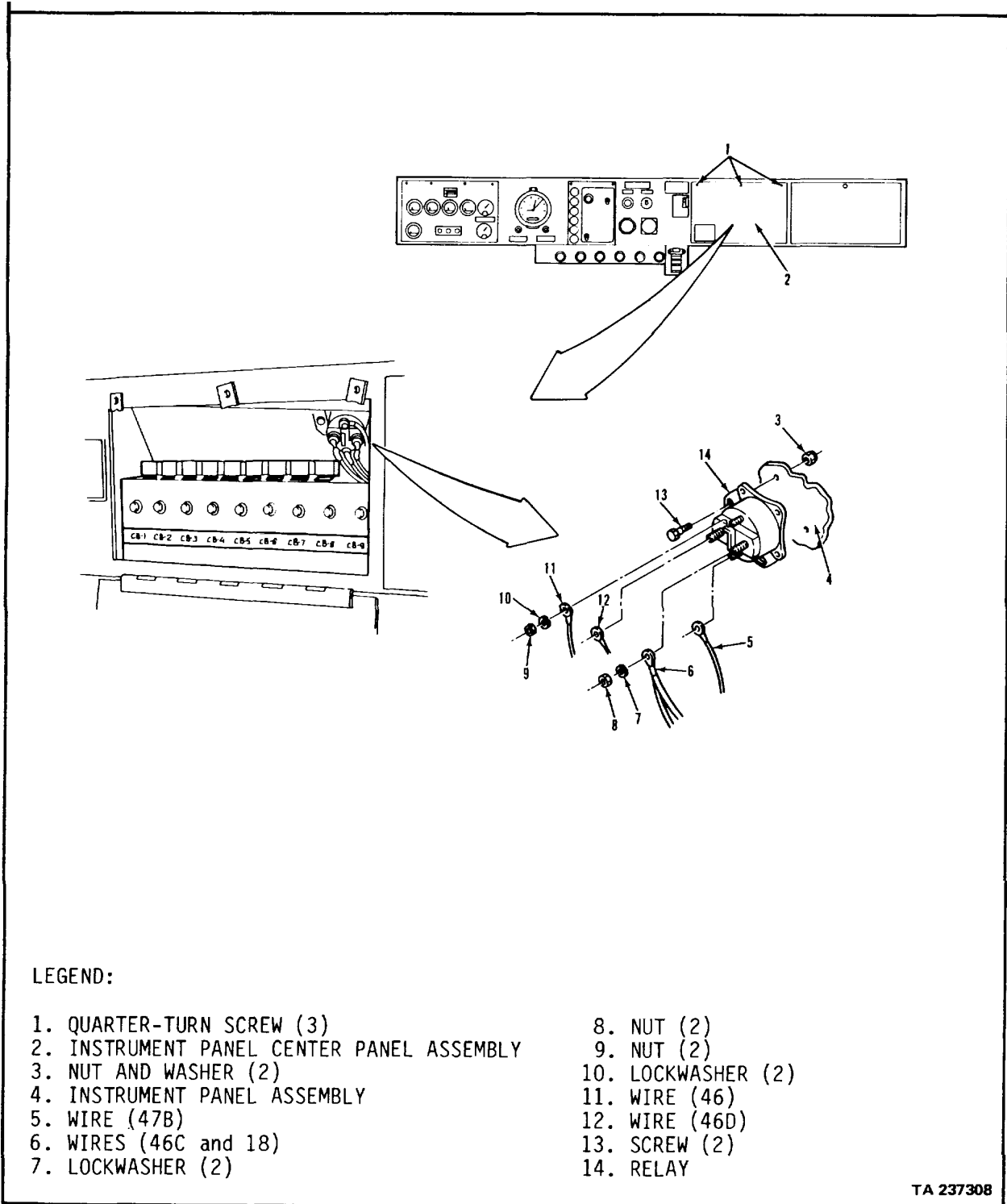

**ELECTRICAL SYSTEM.**

**3-115. STARTER RELAY REPLACEMENT (Continued).**

LOCATION/ITEM	ACTION	REMARKS
<u>A. REMOVAL.</u>		
1. Three screws (1).	Loosen.	
2. Panel (2).	Open.	
3. Two nuts (9), lockwashers (10), wire (11), and wire (5).	Remove from item (14).	Tag wires for identification.
4. Two nuts (8), lockwashers (7), wire (12), and two wires (6).	Remove from item (14).	Tag wires for identification.
5. Two screws (13) and nuts (3).	Remove from item (14) and item (4).	
6. Relay (14).	Remove.	
<u>B. INSTALLATION.</u>		
7. Relay (14).	Put in place on item (4).	
8. Two screws (13) and nuts (3).	Secure two items (14) to item (4).	
9. Two nuts (8) and lockwashers (7).	Secure two items (6) and item (12) to item (14).	Two items (6) go on right side.
10. Two nuts (9) and lockwashers (10).	Secure item (11) and item (5) to item (14).	Item (11) goes on top.
11. Panel (2).	Close.	
12. Three screws (1).	Tighten.	

**NOTE**

**Follow-on maintenance action required: Connect battery power (para 3-120).**

ELECTRICAL SYSTEM.

**3-115. STARTER RELAY REPLACEMENT (Continued).**

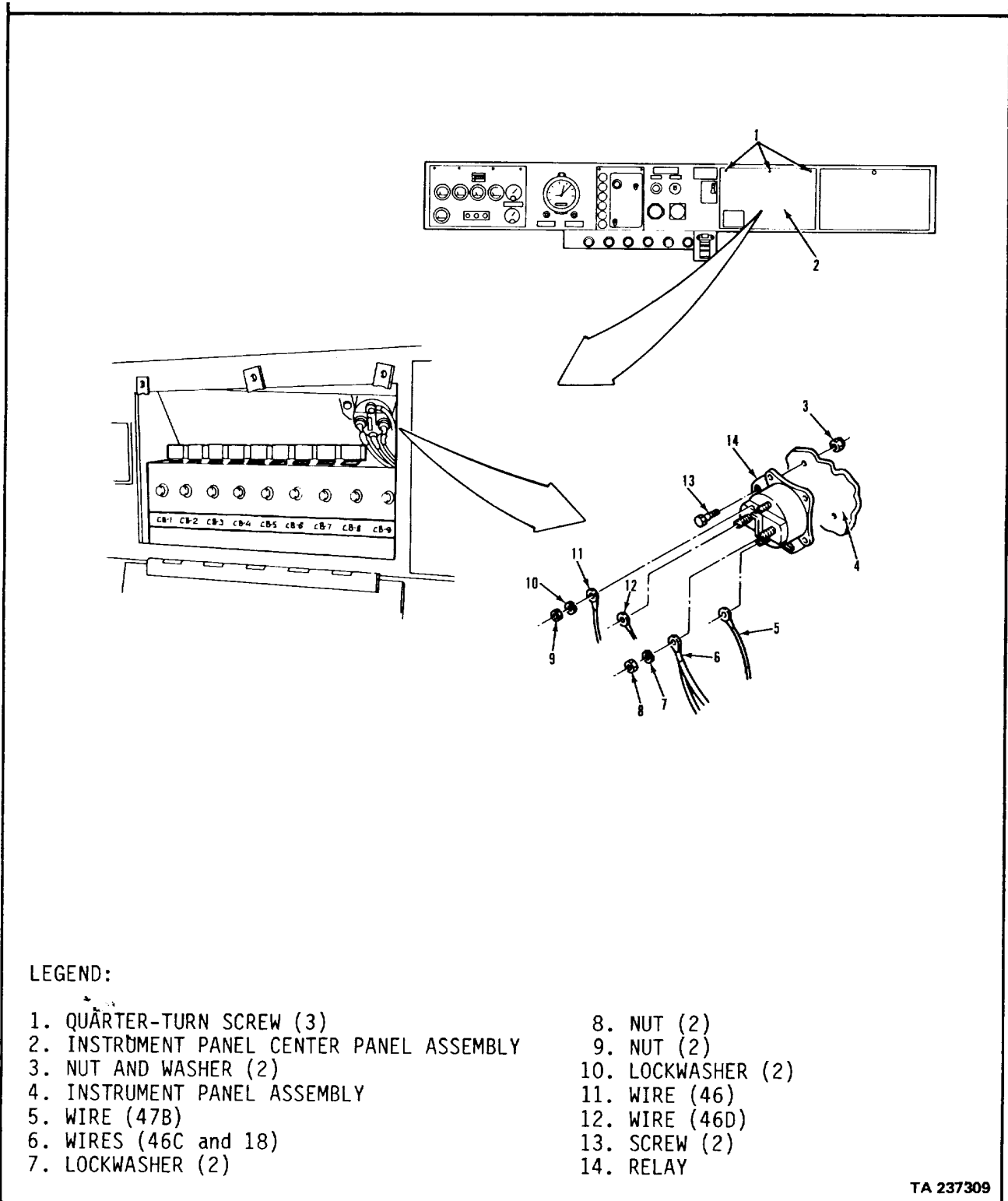

TA 237309

**ELECTRICAL SYSTEM.**

**3-116. STARTING CIRCUIT DIODE REPLACEMENT.**

THIS TASK COVERS

- a. Removal.
- b. Installation.

INITIAL SETUP

APPLICABLE CONFIGURATIONS  
All.

EQUIPMENT CONDITION  
PARAGRAPH  
3-114.

CONDITION DESCRIPTION  
Circuit breaker mounting bracket removed.

TEST EQUIPMENT

None.

SPECIAL TOOLS

None.

MATERIALS/PARTS (P/N)

None.

PERSONNEL REQUIRED

One (MOS-63S).

REFERENCES (TM)

None.

SPECIAL ENVIRONMENTAL CONDITIONS

None.

GENERAL SAFETY INSTRUCTIONS

Engine off.  
Transmission in neutral.  
Park brake set.

TROUBLESHOOTING REFERENCES

Paragraph 2-11.

**3-670**

ELECTRICAL SYSTEM.

3-116. STARTING CIRCUIT DIODE REPLACEMENT (Continued).

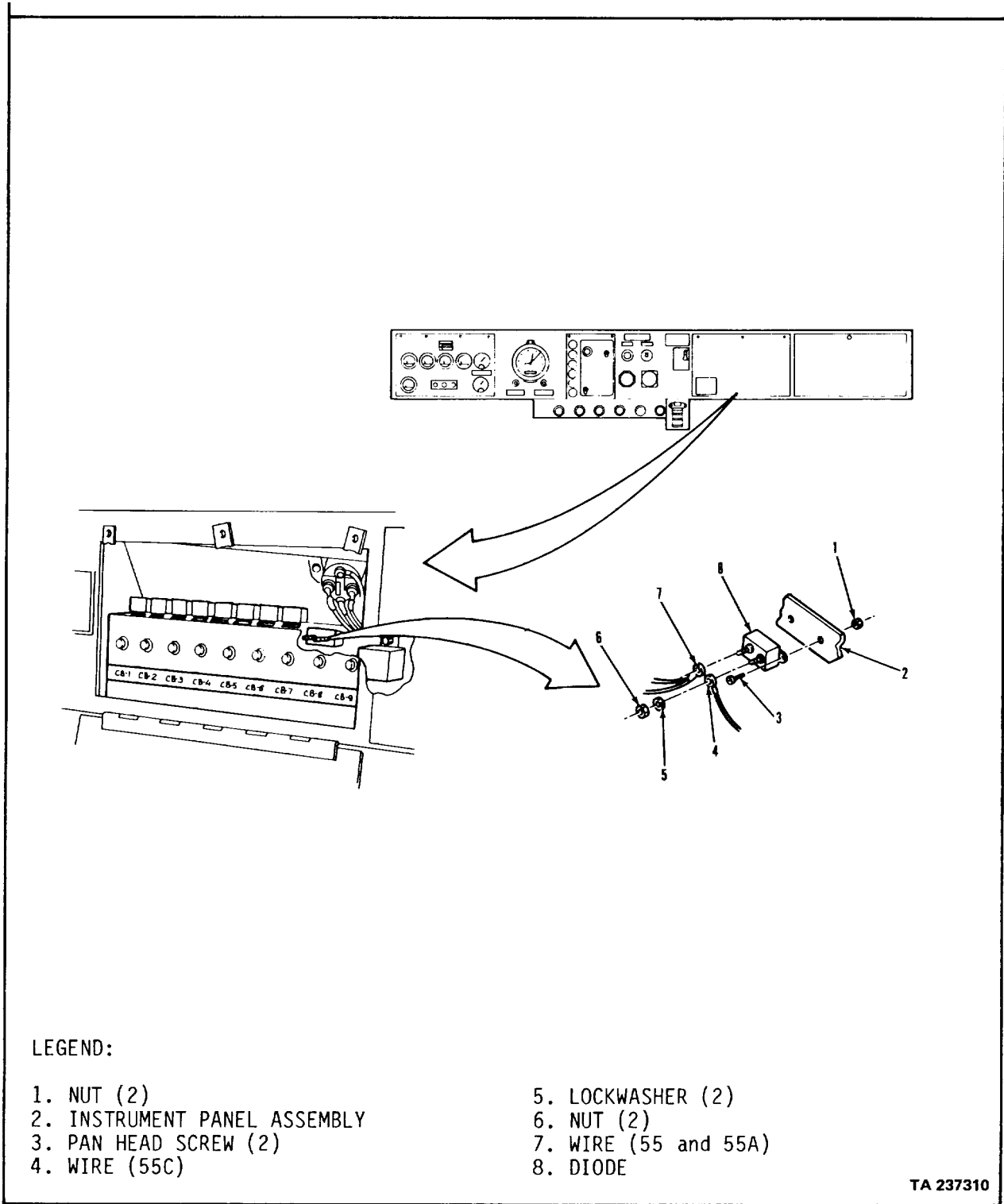

TA 237310

**ELECTRICAL SYSTEM.**

**3-116. STARTING CIRCUIT DIODE REPLACEMENT (Continued).**

LOCATION/ITEM	ACTION	REMARKS
---------------	--------	---------

A. REMOVAL.

- |  |                                    |  |
|--|------------------------------------|--|
| 1. Two nuts (6), lockwashers (5), wires (7), and wire (4). | Remove from item (8).              |  |
| 2. Two screws (3) and nuts (1).                            | Remove from item (8) and item (2). |  |
| 3. Diode (8).  | Remove.                            |  |

B. INSTALLATION

- |                                      |  |   |
|--------------------------------------|--|---|
| 4. Diode (8).                        | Put in place on item (2).                      |   |
| 5. Two screws (3) and nuts (1).      | Secure item (8) to item (2).                   |   |
| 6. Two nuts (6) and lockwashers (5). | Secure two items (7) and item (4) to item (8). | Two items (7) go on gold colored end of item (8). |

**NOTE**  
**Follow-on maintenance action required:**  
**Install circuit breaker mounting**  
**bracket (para 3-114).**



ELECTRICAL SYSTEM.

3-116. STARTING CIRCUIT DIODE REPLACEMENT (Continued).

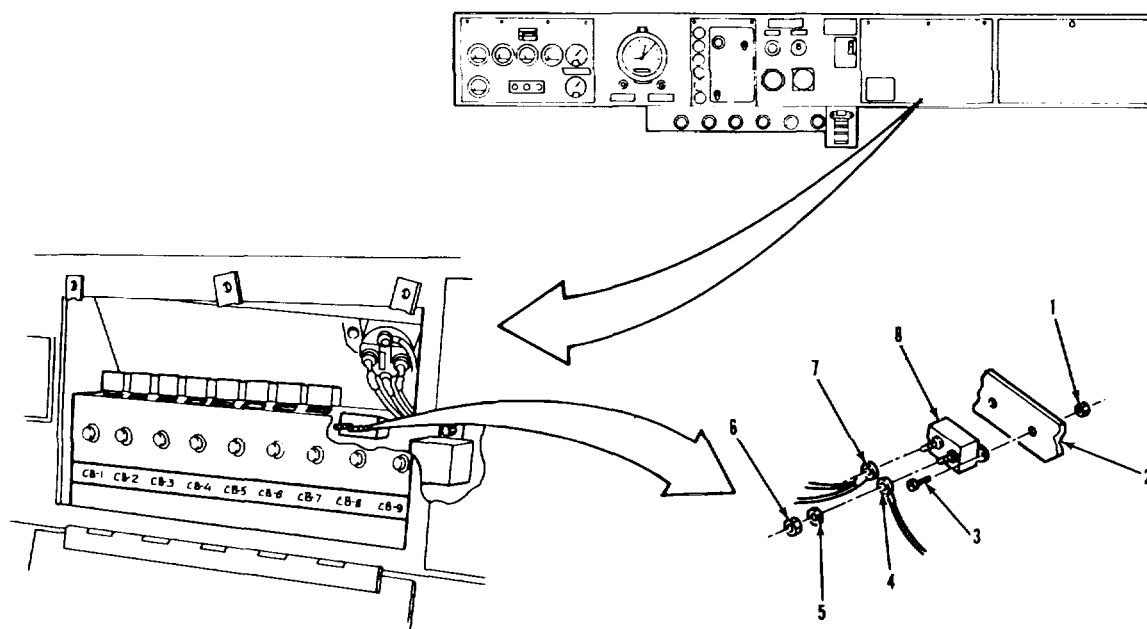

LEGEND:

- 1. NUT (2)
- 2. INSTRUMENT PANEL ASSEMBLY
- 3. PAN HEAD SCREW (2)
- 4. WIRE (55C)

- 5. LOCKWASHER (2)
- 6. NUT (2)
- 7. WIRE (55 and 55A)
- 8. DIODE

TA 237311

**ELECTRICAL SYSTEM.**

**3-117. HORN REPLACEMENT.**

THIS TASK COVERS

- a. Removal.
- b. Cleaning.
- c. Inspection.
- d. Installation.

**INITIAL SETUP**

APPLICABLE CONFIGURATIONS

All.

EQUIPMENT CONDITION  
PARAGRAPH

TM 9-2320-283-10.

CONDITION DESCRIPTION

Hood opened and "S"  
hooks installed.

TEST EQUIPMENT

None.

SPECIAL TOOLS

None.

MATERIALS/PARTS (P/N)

None.

PERSONNEL REQUIRED

One (MOS-63S).

SPECIAL ENVIRONMENTAL CONDITIONS

Vehicle parked on level ground.

REFERENCES (TM)

TM 9-2320-283-10.

GENERAL SAFETY INSTRUCTIONS

Engine off.  
Park brake set.  
Transmission in neutral.

TROUBLESHOOTING REFERENCES

Paragraph 2-11.

ELECTRICAL SYSTEM.

3-117. HORN REPLACEMENT (Continued).

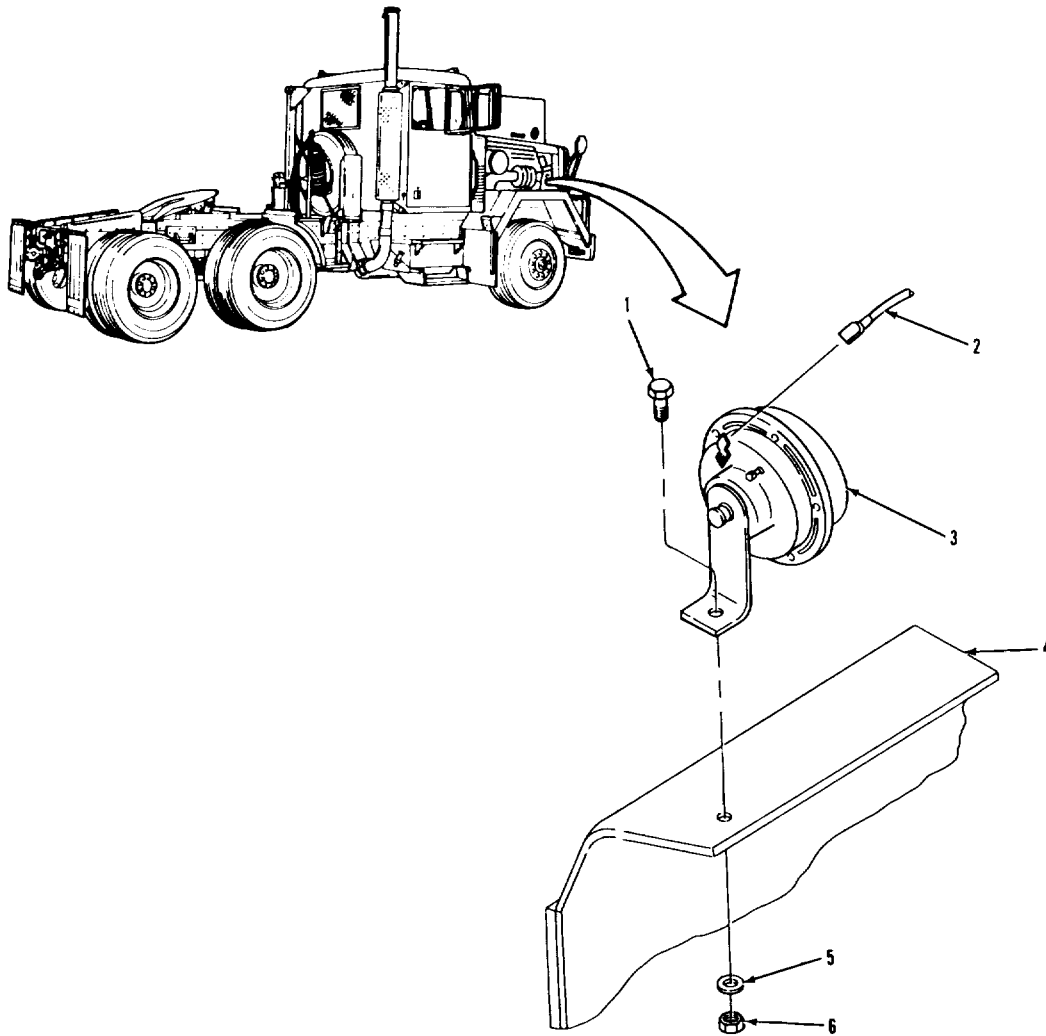

LEGEND:

- 1. HEXAGON HEAD BOLT
- 2. WIRE (41A)
- 3. ELECTRIC HORN ASSEMBLY

- 4. RIGHT-HAND MAIN RAIL
- 5. FLAT WASHER
- 6. HEXAGON HEAD NUT

TA 237312

**ELECTRICAL SYSTEM.**

<b>3-117. HORN REPLACEMENT (Continued).</b>		
<b>LOCATION/ITEM</b>	<b>ACTION</b>	<b>REMARKS</b>
<b>A. REMOVAL.</b>		
1. Wire (2).	Remove from terminal on item (3).	
2. Bolt (1), washer (5), and nut (6).	a. Remove from item (3) and (4). b. Remove item (3) from item (4).	
<b>B. CLEANING.</b>		
3. Horn (3) and rail (4).	Clean mounting surfaces thoroughly with wire brush.	Insures good electrical ground.
4. All metal parts.	Clean.	Refer to paragraph 3-4.
<b>C. INSPECTION</b>		
5. All metal parts.	Inspect.	Refer to paragraph 3-5.
<b>D. INSTALLATION.</b>		
6. Horn (3).	a. Line up hole in item (3) with hole in item (4). b. Secure with items (1), (5), and (6).	
7. Wire (2).	Install on item (3).	
<p><b>NOTE</b>                      Follow-on maintenance action required:                      Close and secure hood (TM 9-2320-283-10).</p>		
<p><b>3-676</b></p>		

ELECTRICAL SYSTEM.

3-117. HORN REPLACEMENT  
Continued)

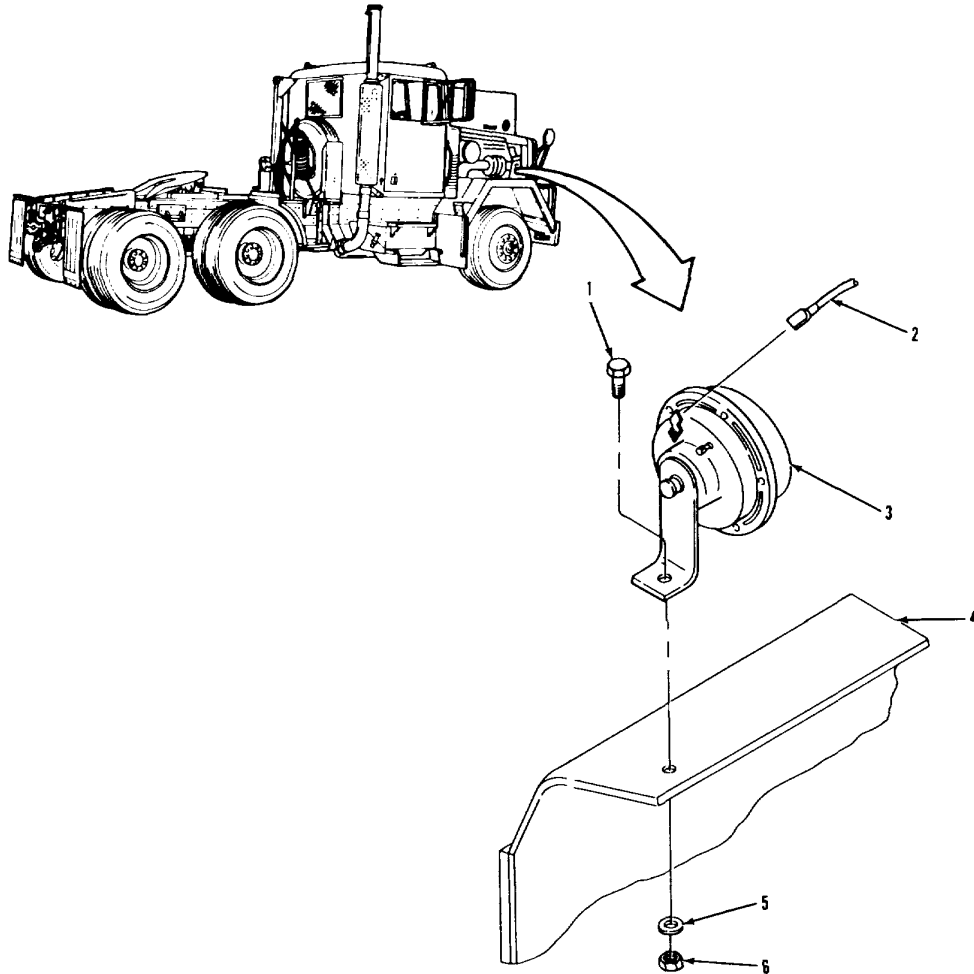

LEGEND:

- 1. HEXAGON HEAD BOLT
- 2. WIRE (41A)
- 3. ELECTRIC HORN ASSEMBLY

- 4. RIGHT-HAND MAIN RAIL
- 5. FLAT WASHER
- 6. HEXAGON HEAD NUT

TA 237313

**ELECTRICAL SYSTEM.**

**3-118. HORN BUTTON REPLACEMENT.**

THIS TASK COVERS

- a. Removal.
- b. Cleaning and Inspection.
- c. Installation.

INITIAL SETUP

APPLICABLE CONFIGURATIONS

All.

EQUIPMENT CONDITION  
PARAGRAPH

3-112.

CONDITION DESCRIPTION

Horn relay removed.

TEST EQUIPMENT

None.

SPECIAL TOOLS

None.

MATERIALS/PARTS (P/N)

None.

PERSONNEL REQUIRED

One (MOS-63SY.

SPECIAL ENVIRONMENTAL CONDITIONS

None.

REFERENCES (TM)

None.

GENERAL SAFETY INSTRUCTIONS

Engine off.  
Park brake set.  
Transmission in neutral.

TROUBLESHOOTING REFERENCES

None.

**3-678**

ELECTRICAL SYSTEM.

3-118. HORN BUTTON REPLACEMENT (Continued).

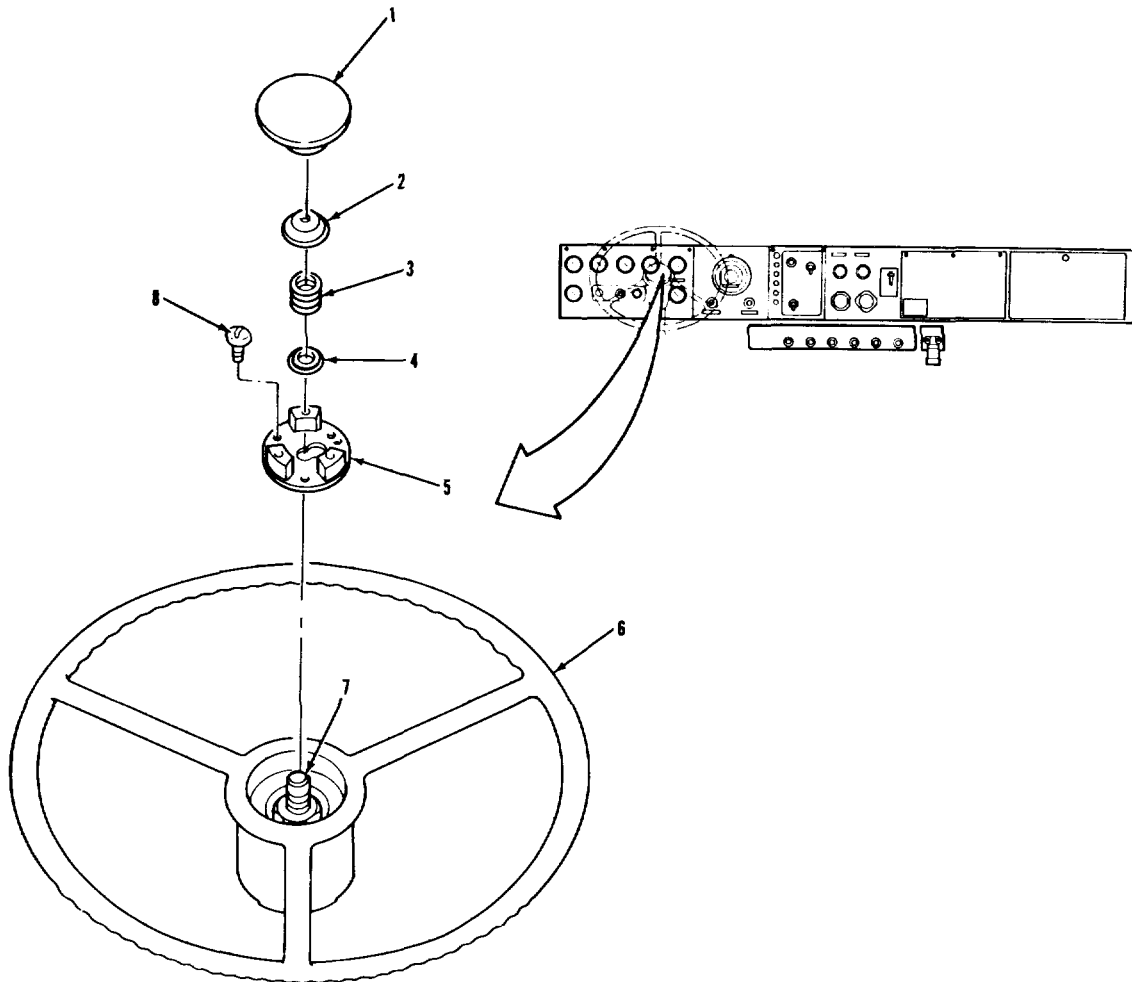

LEGEND:

- 1. HORN BUTTON
- 2. HORN BUTTON CUP
- 3. HORN BUTTON SPRING
- 4. HORN BUTTON CAP

- 5. HORN BUTTON PLATE
- 6. STEERING WHEEL
- 7. CONTACT
- 8. SCREW (3)

TA 237314

**ELECTRICAL SYSTEM.**

<b>3-118. HORN BUTTON REPLACEMENT (Continued).</b>		
<b>LOCATION/ITEM</b>	<b>ACTION</b>	<b>REMARKS</b>
<b>A. REMOVAL</b>		
1. Button (1).	Push completely down and twist counterclockwise, and remove from item (6).	
2. Cup (2), spring (3), and cap (4).	Remove from item (6) and (7).	
3. Three screws (8).	Remove from item (5) and (6).	
4. Plate (5).	Remove from item (6) and (7).	
<b>B. CLEANING AND INSPECTION.</b>		
5. All metal and plastic parts.	Clean and inspect. and 3-5.	Refer to paragraph 3-4
<b>C. INSTALLATION.</b>		
6. Plate (5).	<ul style="list-style-type: none"> <li>a. Pull item (7) up through opening in item (5).</li> <li>b. Line up holes in item (5) with holes in item (6).</li> <li>c. Secure with three items (8).</li> </ul>	
7. Cap (4), spring (3), and cup (2).	Install on item (7).	



3-118. HORN BUTTON REPLACEMENT (Continued).

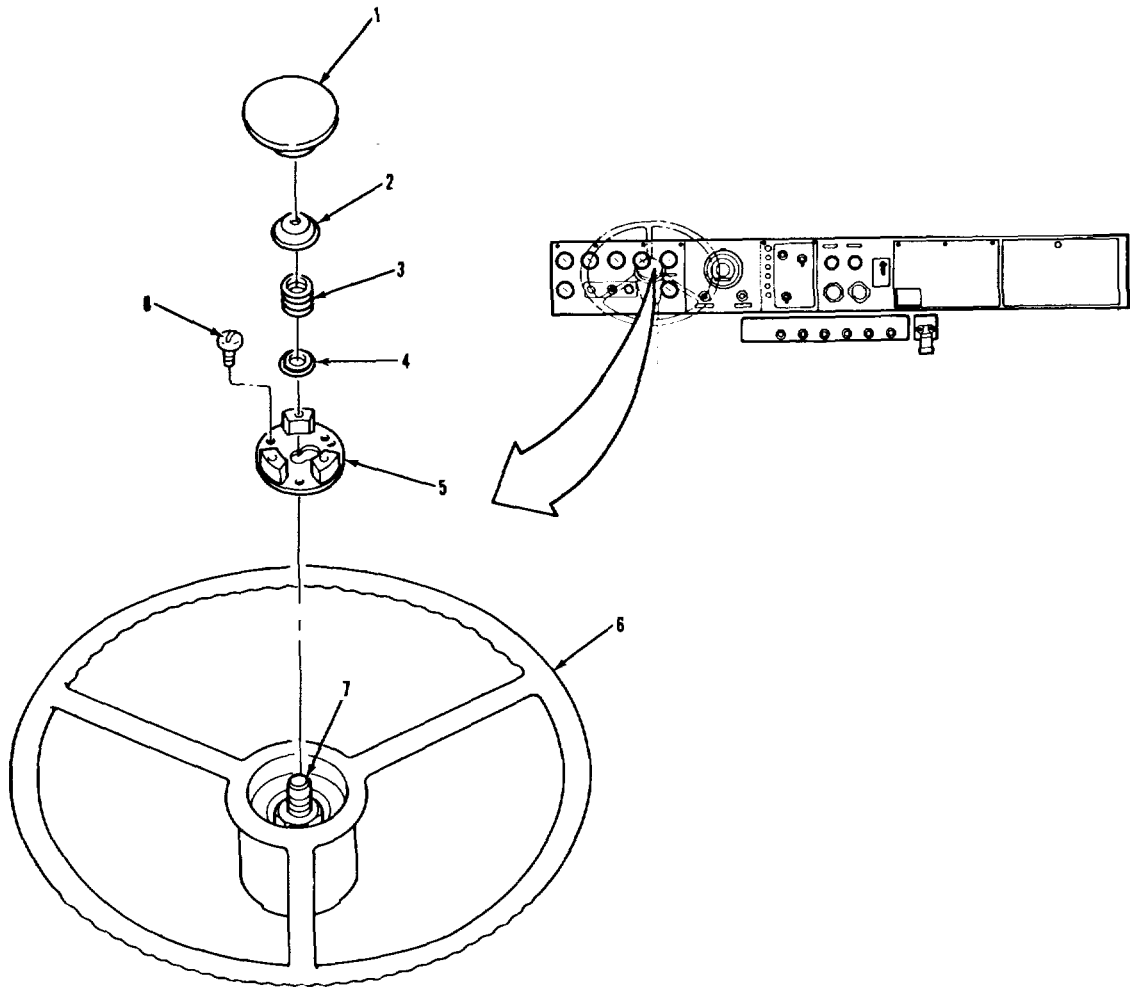

LEGEND:

- 1. HORN BUTTON
- 2. HORN BUTTON CUP
- 3. HORN BUTTON SPRING
- 4. HORN BUTTON CAP

- 5. HORN BUTTON PLATE
- 6. STEERING WHEEL
- 7. CONTACT
- 8. SCREW (3)

TA 237315

**ELECTRICAL SYSTEM.**

<b>3-118. HORN BUTTON REPLACEMENT (Continued).</b>		
<b>LOCATION/ITEM</b>	<b>ACTION</b>	<b>REMARKS</b>
<b>C. INSTALLATION (Continued).</b>		
8. Button (1).	a. Position over item (2). b. Push down and turn clockwise.	
<p>NOTE</p> <p><b>Follow-on maintenance action required:</b></p> <p><b>Install horn relay (para 3-112).</b></p>		

ELECTRICAL SYSTEM.

3-118. HORN BUTTON REPLACEMENT (Continued).

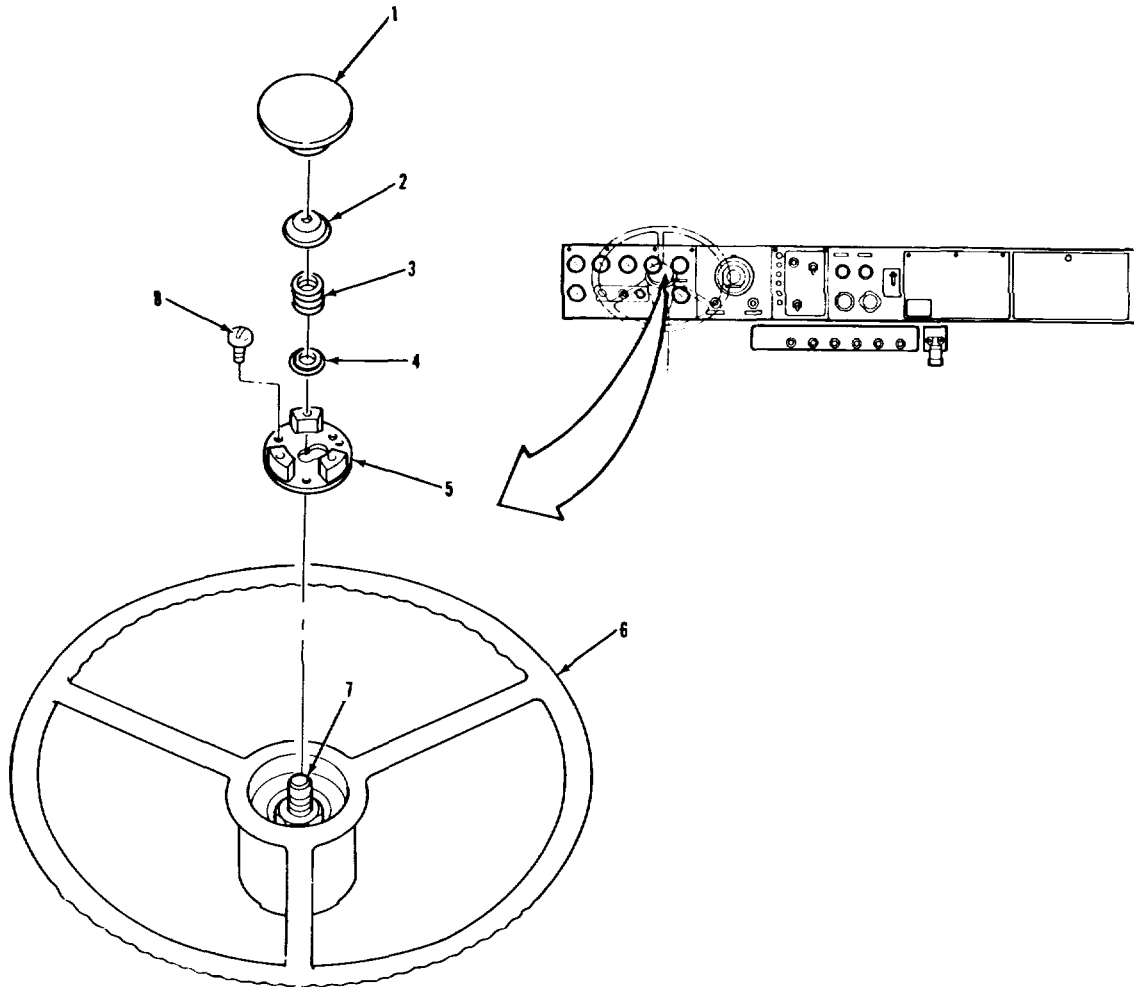

LEGEND:

- |                       |                      |
|-----------------------|----------------------|
| 1. HORN BUTTON        | 5. HORN BUTTON PLATE |
| 2. HORN BUTTON CUP    | 6. STEERING WHEEL    |
| 3. HORN BUTTON SPRING | 7. CONTACT           |
| 4. HORN BUTTON CAP    | 8. SCREW (3)         |

TA 237316

**ELECTRICAL SYSTEM.**

**3-119. BATTERY CHARGING.**

---

THIS TASK COVERS

- a. Connect Charger.
  - b. Charge Battery.
  - c. Disconnect Charger.
- 

INITIAL SETUP

<u>APPLICABLE CONFIGURATIONS</u>	<u>EQUIPMENT CONDITION PARAGRAPH</u>	<u>CONDITION DESCRIPTION</u>
All.		
 <u>TEST EQUIPMENT</u> None.		NOTE If it is necessary to remove batteries for charging, do the following:
 <u>SPECIAL TOOLS</u> None.	3-121.	Remove low charge battery.
 <u>MATERIALS/PARTS (P/N)</u> Grease, automotive and artillery Item 7, Appendix C,		
 <u>PERSONNEL REQUIRED</u> One (MOS-63S ).	 <u>SPECIAL ENVIRONMENTAL CONDITIONS</u> None.	
 <u>REFERENCES (TM)</u> None.	 <u>GENERAL SAFETY INSTRUCTIONS</u> Engine off. Transmission in neutral. Park brake set. Wear safety goggles.	
 <u>TROUBLESHOOTING REFERENCES.</u> Paragraph 2-11.		

ELECTRICAL SYSTEM.

3-119. BATTERY CHARGING (Continued).

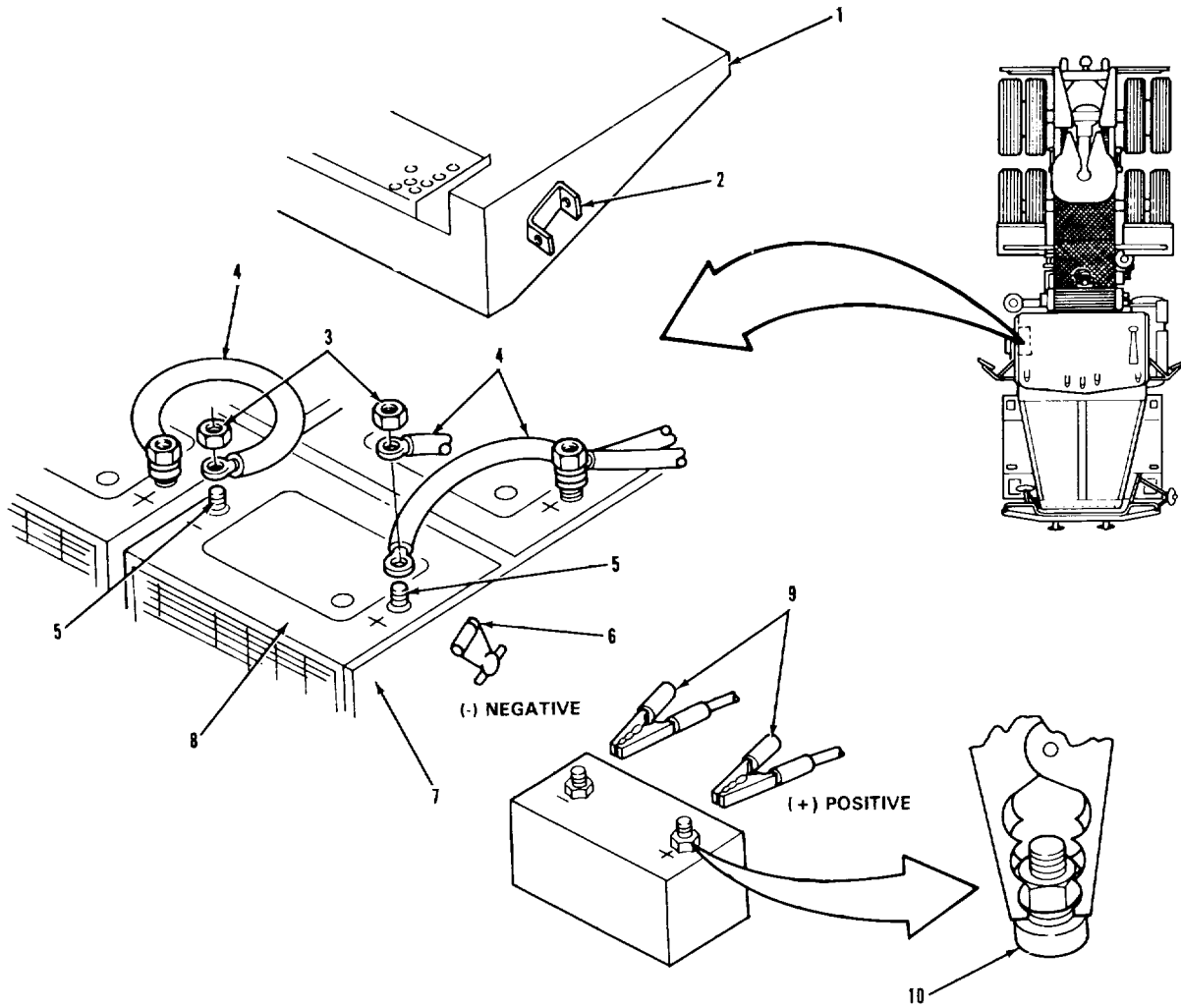

LEGEND:

- |                                     |                        |
|-------------------------------------|------------------------|
| 1. BATTERY BOX COVER                | 6. HOOD HOOK (2)       |
| 2. HOOD HOOK BRACKET (2)            | 7. BATTERY BOX         |
| 3. NUT (2)                          | 8. BATTERY (4)         |
| 4. POSITIVE BATTERY POWER CABLE (3) | 9. ALLIGATOR CLAMP (2) |
| 5. TERMINAL (2)                     | 10. LEAD PAD (2)       |

TA 237317

ELECTRICAL SYSTEM.

3-119. BATTERY CHARGING (Continued).		
LOCATION/ITEM	ACTION	REMARKS
<div style="border: 1px solid black; padding: 2px; display: inline-block;">A. CONNECT CHARGER</div>		
NOTE		
<p>* Skip steps 1 thru 5 if battery is removed.</p> <p>* All batteries are charged in similar manner. One battery shown here.</p>		
1. Two hooks (6).	Remove from two items (2).	
2. Cover (1).	Lift up and pull away from vehicle.	
<p><b><u>WARNING</u></b></p> <p><b>Always remove negative battery ground cables first to avoid sparks and explosion. Failure to follow this precaution may result in serious injury to you and other personnel.</b></p>		
3. Battery (8).	Disconnect from ground.	Refer to paragraph 3-120.
4. Two nuts (3).	Remove from two items (5).	
5. Three cables (4).	<p>a. Remove from two items (5).</p> <p>b. Tag items (4).</p>	
6. Two nuts (3).	Install back onto two items (5).	This is done to insure that a good contact will be maintained between items (9) and items (10) during charging.

ELECTRICAL SYSTEM.

3-119. BATTERY CHARGING (Continued).

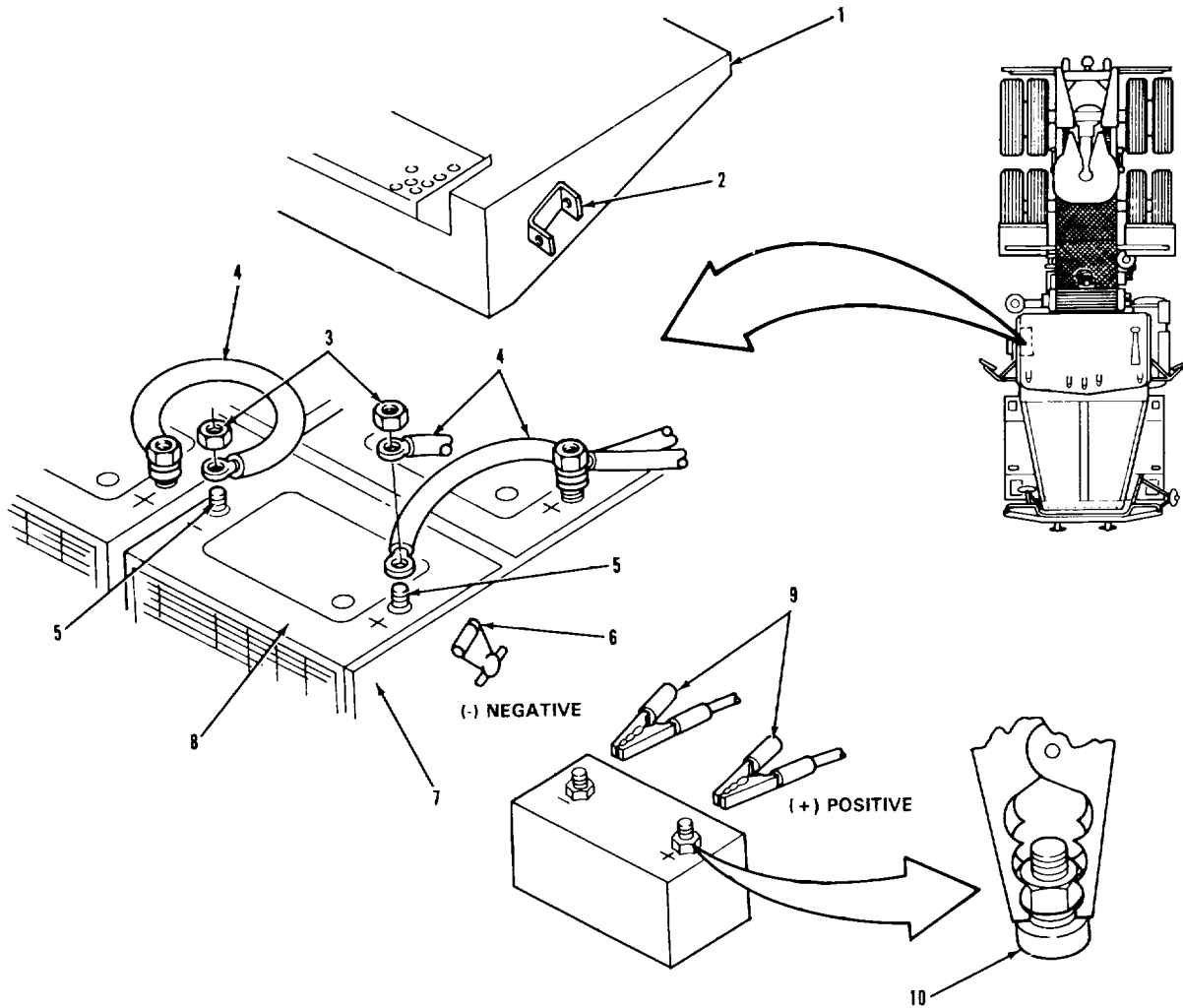

LEGEND:

- |                                     |                        |
|-------------------------------------|------------------------|
| 1. BATTERY BOX COVER                | 6. HOOD HOOK (2)       |
| 2. HOOD HOOK BRACKET (2)            | 7. BATTERY BOX         |
| 3. NUT (2)                          | 8. BATTERY (4)         |
| 4. POSITIVE BATTERY POWER CABLE (3) | 9. ALLIGATOR CLAMP (2) |
| 5. TERMINAL (2)                     | 10. LEAD PAD (2)       |

TA 237317

ELECTRICAL SYSTEM.

3-119. BATTERY CHARGING (Continued).		
LOCATION/ITEM	ACTION	REMARKS
<p>A. CONNECT CHARGER (Continued).</p> <p style="text-align: center;"><b><u>WARNING</u></b></p> <p>Be sure charger is off before connecting clamps to battery, otherwise sparks may result, causing an explosion. Failure to follow this precaution may result in serious injury to you and other personnel.</p> <p style="text-align: center;"><b><u>CAUTION</u></b></p> <p>Turn off charger if battery feels hot (125°F) or begins gassing and spewing electrolyte. Damage to batteries will occur if either of these conditions persist for a length of time.</p> <p style="text-align: center;">NOTE</p> <p>Battery does not need charging when battery test indicator shows green or light yellow condition. If light yellow condition exists, replace battery (para 3-121).</p>		
7. Two clamps (9).	Install between two items (3) and (10).	Positive item (9) connects to positive item (5) and negative item (9) connects to negative item (5).
<p>B. CHARGE BATTERY. I</p> <p style="text-align: center;">NOTE</p> <p>*Shake or tilt battery at hourly intervals to mix electrolyte and to self indicator is green.</p> <p>*Stop charging when indicator is green.</p>		
8. Battery (8).	Charge.	Refer to the battery charging rates on page 3-690.



ELECTRICAL SYSTEM.

3-119. BATTERY CHARGING (Continued).

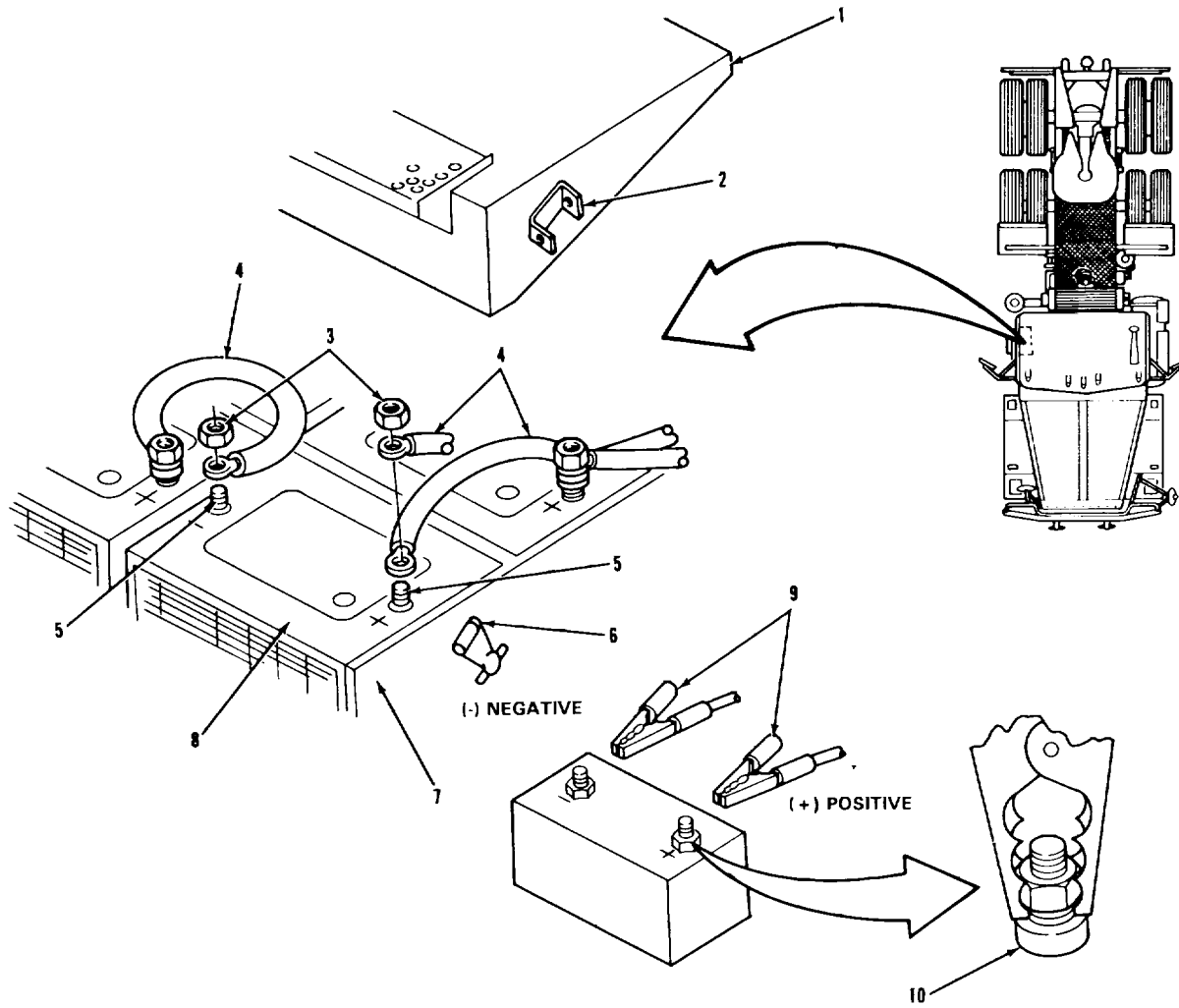

LEGEND:

- |                                     |                        |
|-------------------------------------|------------------------|
| 1. BATTERY BOX COVER                | 6. HOOD HOOK (2)       |
| 2. HOOD HOOK BRACKET (2)            | 7. BATTERY BOX         |
| 3. NUT (2)                          | 8. BATTERY (4)         |
| 4. POSITIVE BATTERY POWER CABLE (3) | 9. ALLIGATOR CLAMP (2) |
| 5. TERMINAL (2)                     | 10. LEAD PAD (2)       |

TA 237319

ELECTRICAL SYSTEM.

3-119. BATTERY CHARGING (Continued).		
LOCATION/ITEM	ACTION	REMARKS
B. CHARGE BATTERY (Continued).		
BATTERY CHARGING RATES		
<u>Battery Model</u>	<u>Slow Charging Rate</u>	<u>Fast Charging Rate</u>
1200	5A at 15 hours 10A at 7-1/2 hours	20A at 3-3/4 hours 30A at 2-1/2 hours 40A at 2 hours 50A at 1-1/2 hours
C. DISCONNECT CHARGER.		
<b><u>WARNING</u></b>		
<b>Be sure charger is off before removing clamps from battery; otherwise, sparks may result, causing an explosion. Failure to follow this precaution may result in serious injury to you and other personnel.</b>		
9. Two clamps (9) and nuts (3).	Remove from item (5).	
NOTE		
Skip step 10 if battery was not removed for charging.		
10. Battery (8).	a. Install.	Refer to paragraph 3-121.
	b. Go to follow-on maintenance.	

ELECTRICAL SYSTEM.

3-119. BATTERY CHARGING (Continued).

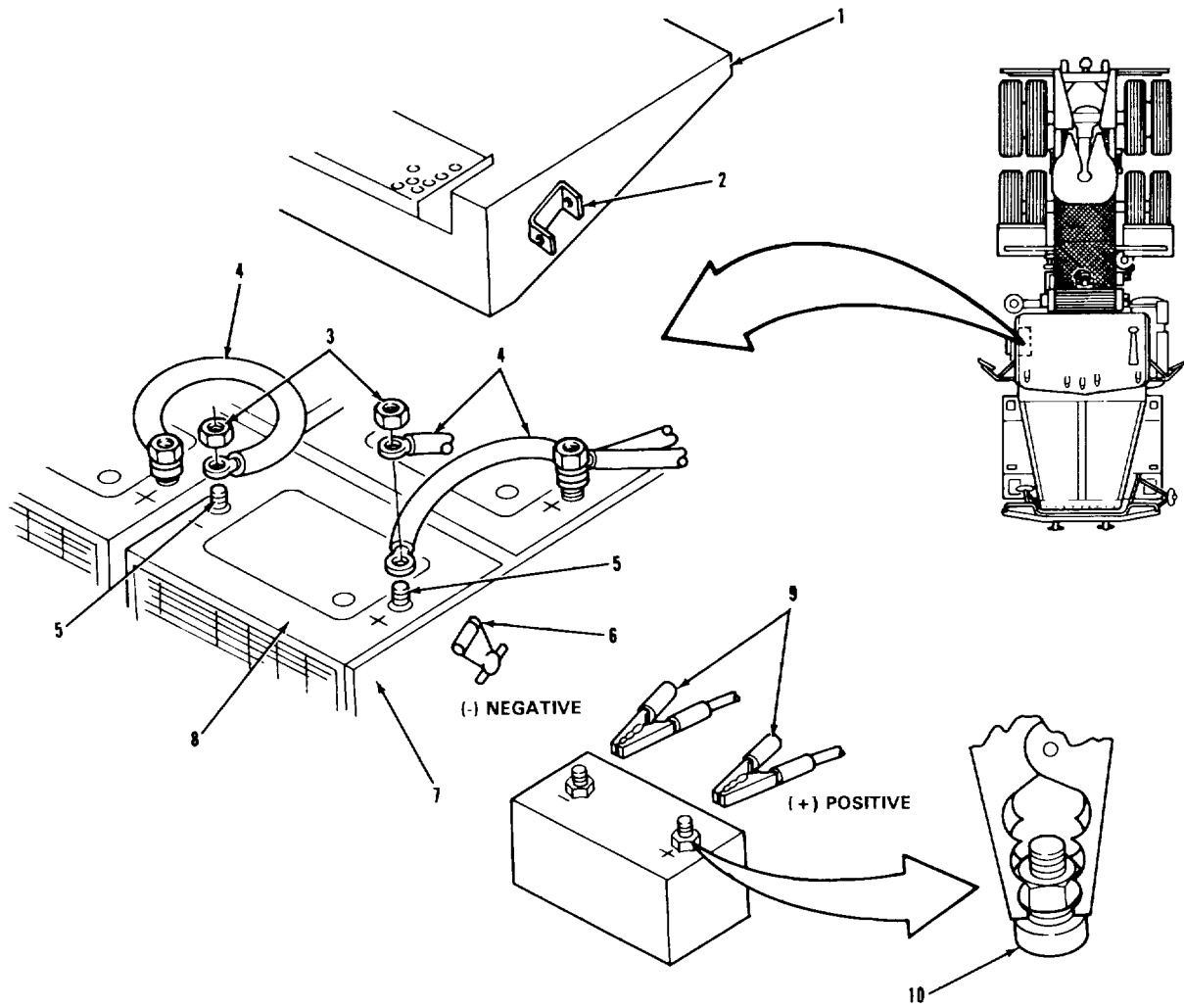

LEGEND:

- |                                     |                        |
|-------------------------------------|------------------------|
| 1. BATTERY BOX COVER                | 6. HOOD HOOK (2)       |
| 2. HOOD HOOK BRACKET (2)            | 7. BATTERY BOX         |
| 3. NUT (2)                          | 8. BATTERY (4)         |
| 4. POSITIVE BATTERY POWER CABLE (3) | 9. ALLIGATOR CLAMP (2) |
| 5. TERMINAL (2)                     | 10. LEAD PAD (2)       |

TA 237320

ELECTRICAL SYSTEM.

3-119. BATTERY CHARGING (Continued).		
LOCATION/ITEM	ACTION	REMARKS
C. DISCONNECT CHARGER (Continued).		
<p><b><u>WARNING</u></b></p> <p>Always install negative battery ground cables last to avoid sparks and explosion. Failure to follow this precaution may result in serious injury to you and other personnel.</p> <p><b><u>CAUTION</u></b></p> <p>Make sure battery is connected in series-parallel. Failure to properly connect battery can result in severe damage to vehicle electrical system.</p>		
11. Three cables (4).	a. Install on two items (5) (See illustration).	
b. Secure with two items (3).		
c. Coat items (3) and (4) with grease.		
12. Cover (1).	a. Line up two pins on item (1) with holes in item (7).	
	b. Push item (1) in and lower onto item (7).	
	c. Secure with two items (6).	
<p>NOTE</p> <p>Follow-on maintenance action required: None.</p>		
<p><b>3-692</b></p>		

ELECTRICAL SYSTEM.

3-119. BATTERY CHARGING (Continued).

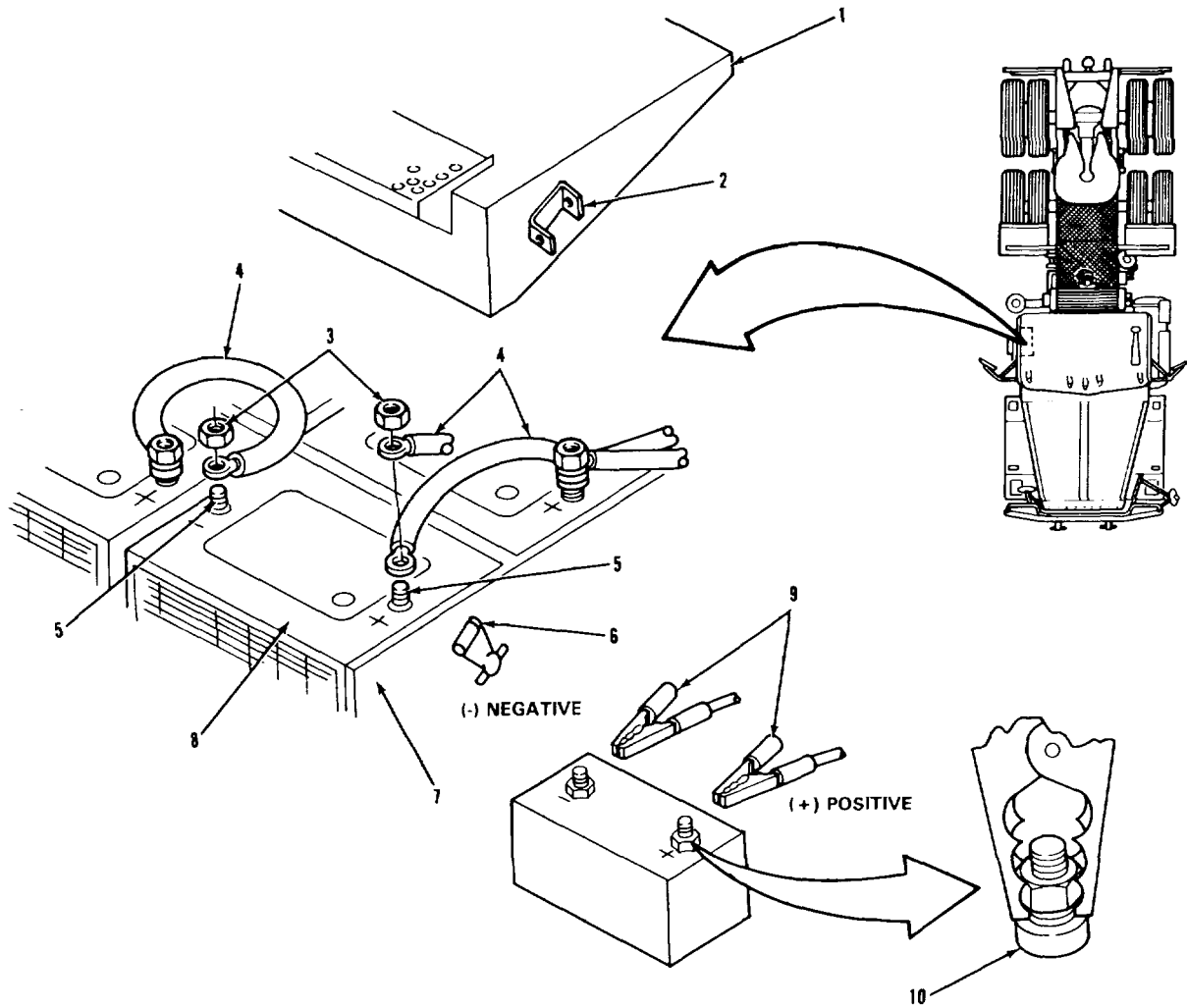

LEGEND:

- |                                     |                        |
|-------------------------------------|------------------------|
| 1. BATTERY BOX COVER                | 6. HOOD HOOK (2)       |
| 2. HOOD HOOK BRACKET (2)            | 7. BATTERY BOX         |
| 3. NUT (2)                          | 8. BATTERY (4)         |
| 4. POSITIVE BATTERY POWER CABLE (3) | 9. ALLIGATOR CLAMP (2) |
| 5. TERMINAL (2)                     | 10. LEAD PAD (2)       |

TA 237321

**ELECTRICAL SYSTEM.****3-120. BATTERY POWER DISCONNECT AND CONNECT PROCEDURE.**

---

## THIS TASK COVERS

- a. Disconnect.
  - b. Cleaning.
  - c. Inspection.
  - d. Connect.
- 

INITIAL SETUPAPPLICABLE CONFIGURATIONS

All.

EQUIPMENT CONDITION  
PARAGRAPH

None.

CONDITION DESCRIPTION

None.

TEST EQUIPMENT

None.

SPECIAL TOOLS

None.

MATERIALS/PARTS (P/N)

Grease, automotive and artillery

Item 7, Appendix C.

Rag, wiping

Item 22, Appendix C.

Sodium bicarbonate (baking soda)

Item 27, Appendix C.

PERSONNEL REQUIRED

One (MOS-63S).

SPECIAL ENVIRONMENTAL CONDITIONS

None.

REFERENCES (TM)

None.

GENERAL SAFETY INSTRUCTIONS

Engine off.

Transmission in neutral.

Park brake set.

Wear safety goggles.

TROUBLESHOOTING REFERENCES

Paragraph 2-11.

**3-694**

ELECTRICAL SYSTEM.

3-120. BATTERY POWER DISCONNECT AND CONNECT PROCEDURE (Continued).

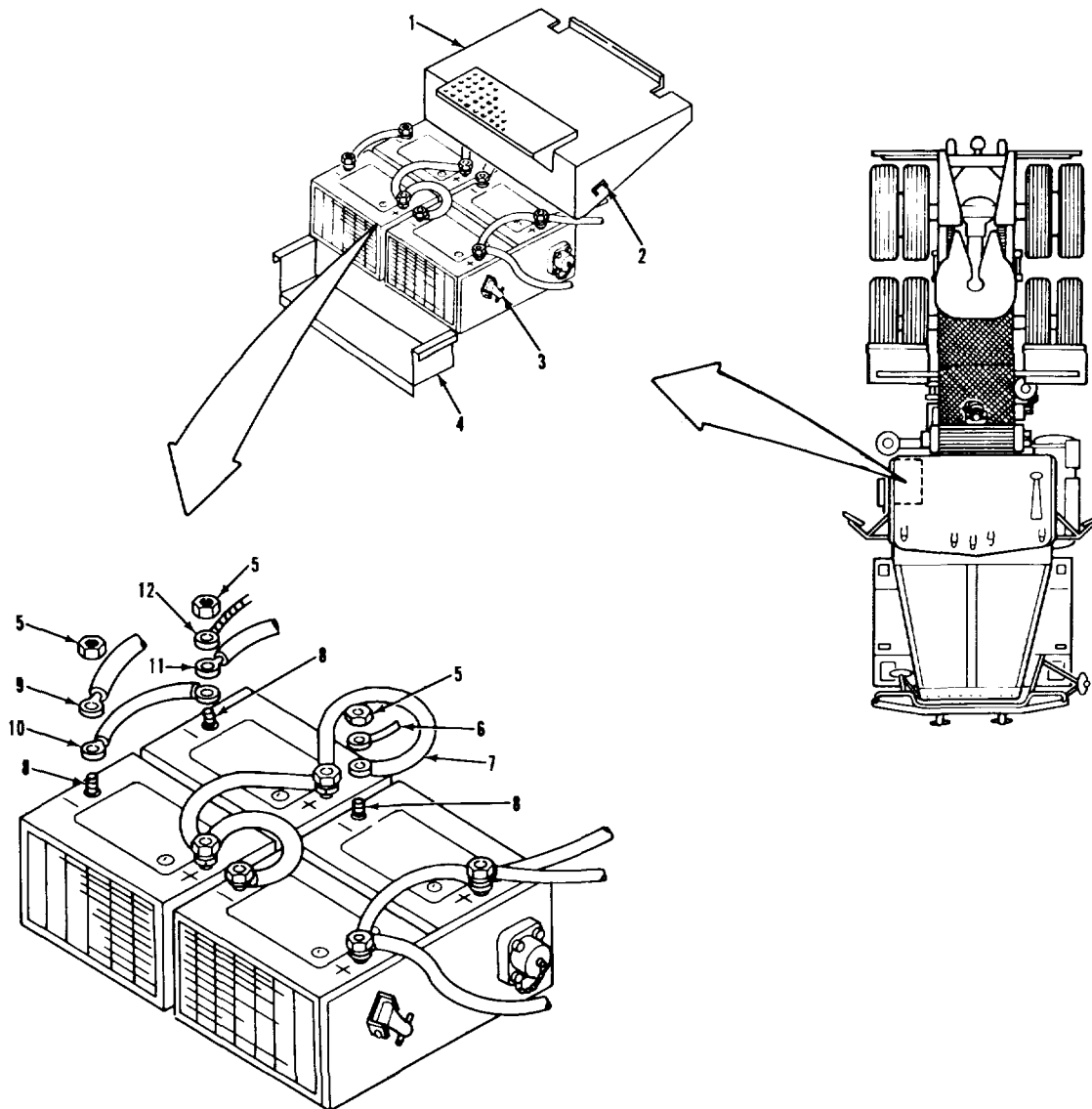

LEGEND:

- |  |   |
|--|---|
| 1. BATTERY BOX COVER                   | 8. TERMINAL (3)   |
| 2. HOOD HOOK BRACKET (2)               | 9. NEGATIVE BATTERY POWER CABLE (BATTERY-TO-RECEPTACLE)     |
| 3. HOOD HOOK (2)                       | 10. NEGATIVE BATTERY POWER CABLE                            |
| 4. BATTERY BOX                         | 11. NEGATIVE BATTERY POWER CABLE (BATTERY-TO-STARTER MOTOR) |
| 5. NUT (3)                             | 12. STE/ICE NEGATIVE POWER CABLE                            |
| 6. ENGINE HARNESS 12-VOLT SUPPLY CABLE |   |
| 7. POSITIVE BATTERY POWER CABLE        |   |

TA 237322

ELECTRICAL SYSTEM.

3-120. BATTERY POWER DISCONNECT AND CONNECT PROCEDURE (Continued).		
LOCATION/ITEM	ACTION	REMARKS
<b>A. DISCONNECT.</b>		
1. Two hooks (3).	<ul style="list-style-type: none"> <li>a. Remove from two items (2).</li> <li>b. Lift item (1) from item (4).</li> </ul>	
<p><b><u>WARNING</u></b></p> <p><b>Disconnect engine harness 12-volt supply cable last. If cable is disconnected first, sparks may result causing a possible explosion. Failure to follow this precaution could result in serious injury to you and other personnel.</b></p>		
2. Two nuts (5).	<ul style="list-style-type: none"> <li>a. Remove from two items (8).</li> <li>b. Remove items (9), (10), (11), and (12) from item (8).</li> <li>c. Tag items (9), (10), (11), and (12).</li> </ul>	
3. Nut (5).	<ul style="list-style-type: none"> <li>a. Remove from item (8).</li> <li>b. Remove items (6) and (7) from item (8).</li> <li>c. Tag items (6) and (7).</li> </ul>	
<b>B. CLEANING</b>		
4. Cables (6), (7), (9), (10), (11), (12), and three terminals (8).	<ul style="list-style-type: none"> <li>a. Clean with wire brush and sodium bicarbonate.</li> <li>b. Rinse with clear water and dry thoroughly with clean dry rags.</li> </ul>	



ELECTRICAL SYSTEM.

3-120. BATTERY POWER DISCONNECT AND CONNECT PROCEDURE (Continued).

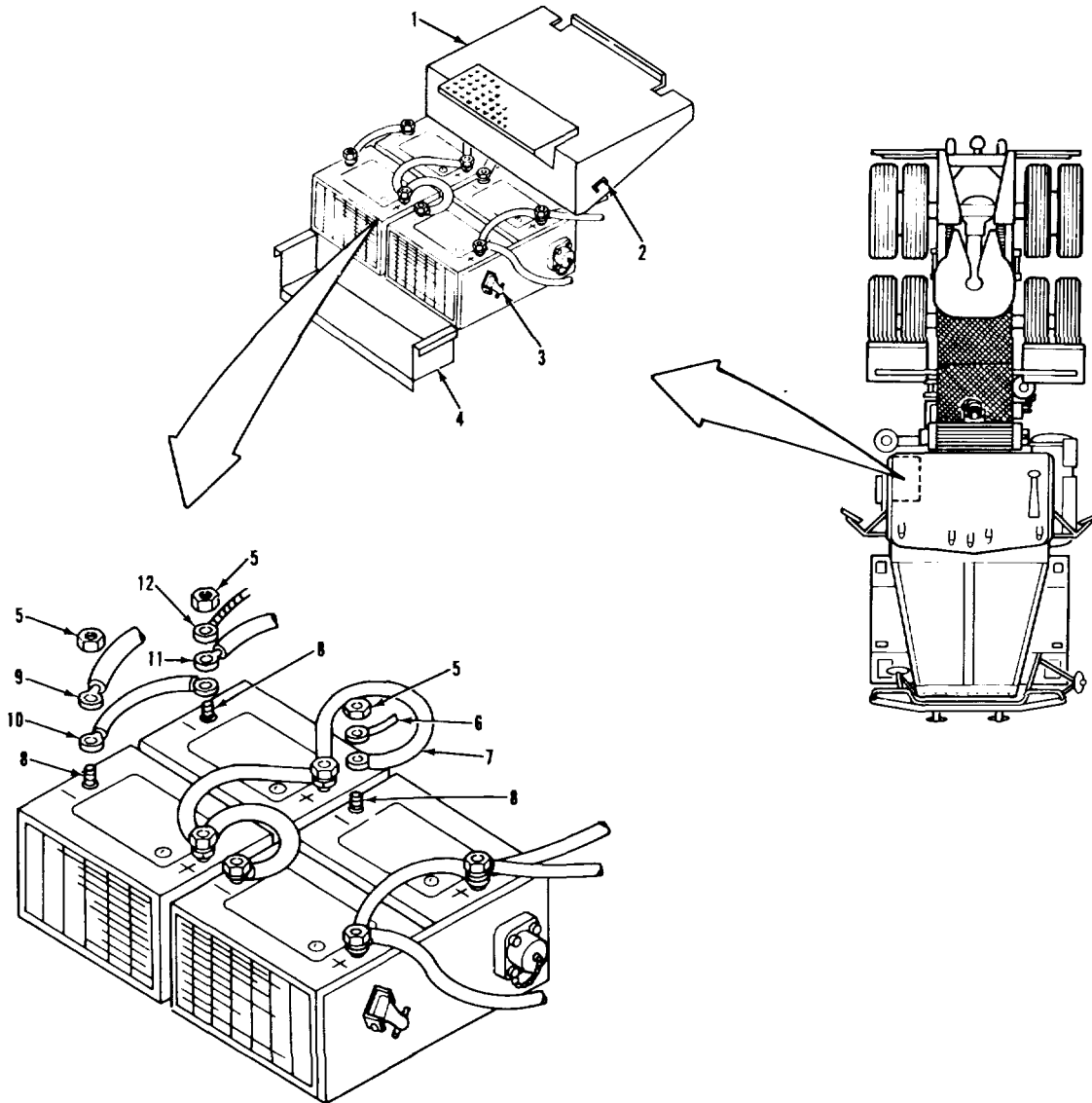

LEGEND:

- |  |  |
|--|--|
| 1. BATTERY BOX COVER                   | 8. TERMINAL (3)  |
| 2. HOOD HOOK BRACKET (2)               | 9. NEGATIVE BATTERY POWER CABLE<br>(BATTERY-TO-RECEPTACLE)     |
| 3. HOOD HOOK (2)                       | 10. NEGATIVE BATTERY POWER CABLE                               |
| 4. BATTERY BOX                         | 11. NEGATIVE BATTERY POWER CABLE<br>(BATTERY-TO-STARTER MOTOR) |
| 5. NUT (3)                             | 12. STE/ICE NEGATIVE POWER CABLE                               |
| 6. ENGINE HARNESS 12-VOLT SUPPLY CABLE |  |
| 7. POSITIVE BATTERY POWER CABLE        |  |

TA 237323

ELECTRICAL SYSTEM.

3-120. BATTERY POWER DISCONNECT AND CONNECT PROCEDURE (Continued).		
LOCATION/ITEM	ACTION	REMARKS
<b>C. INSPECTION.</b>		
5. All metal parts.	Inspect.	Refer paragraph 3-5.
<b>D. CONNECT.</b>		
<b><u>WARNING</u></b>		
<p><b>Connect engine harness 12-volt supply cable first. If cable is connected last, sparks may result causing a possible explosion. Failure to follow this precaution could result in serious injury to you and other personnel.</b></p>		
<b><u>CAUTION</u></b>		
<p><b>Make sure battery is connected in series-parallel. Failure to properly connect batteries can result in severe damage to vehicle electrical system.</b></p>		
6. Cable (6) and (7).	<ul style="list-style-type: none"> <li>a. Install on item (8).</li> <li>b. Secure with item (5).</li> </ul>	See illustration.
7. Cable (9) and (10) and (11) and (12).	<ul style="list-style-type: none"> <li>a. Install two on items (8).</li> <li>b. Secure with two items (5).</li> <li>c. Coat items (6), (7), (8), (9), (10), (11), and (12) with grease.</li> </ul>	See illustration.

ELECTRICAL SYSTEM.

3-120. BATTERY POWER DISCONNECT AND CONNECT PROCEDURE (Continued).

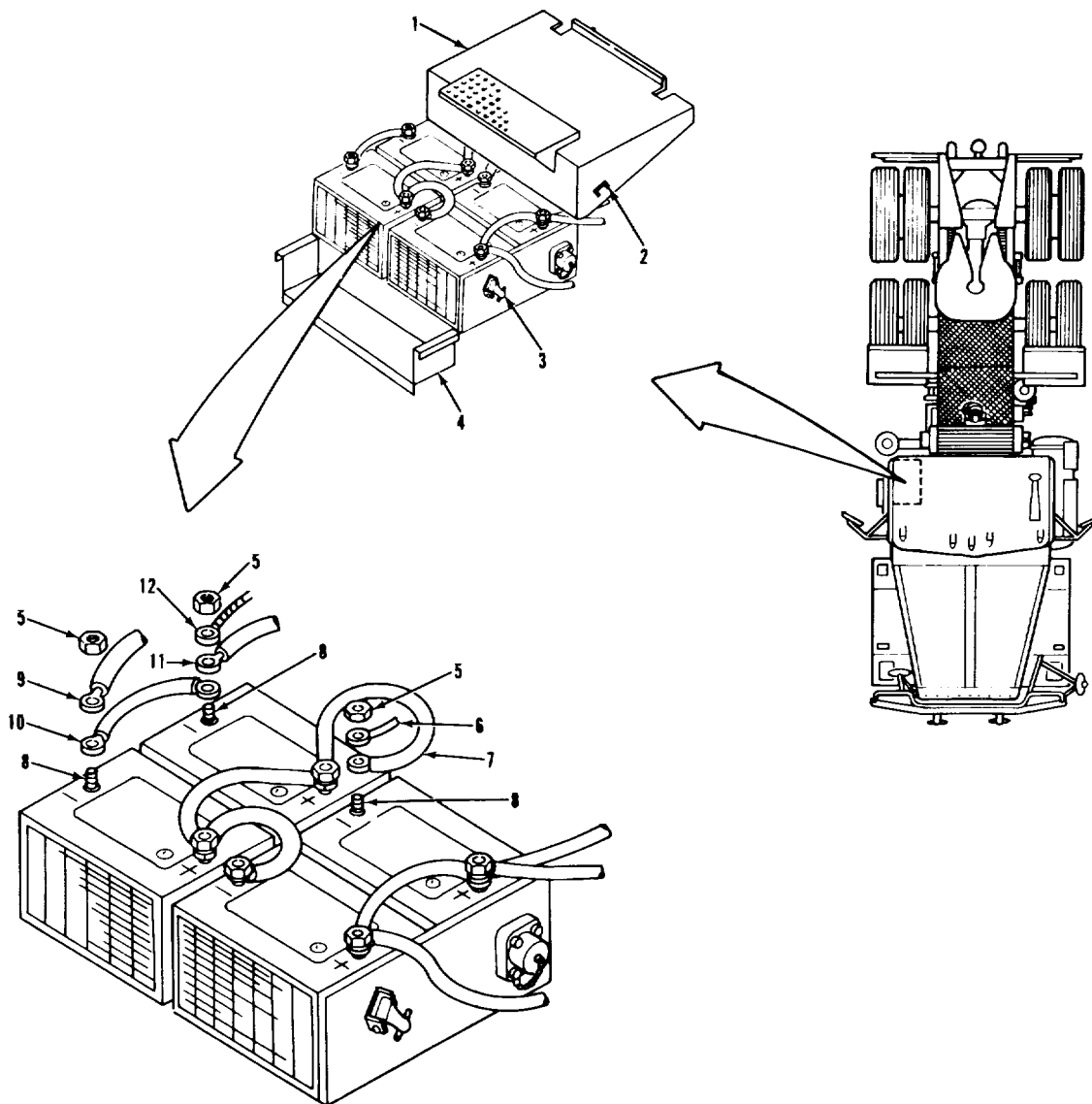

LEGEND:

- |  |   |
|--|---|
| 1. BATTERY BOX COVER                   | 8. TERMINAL (3)   |
| 2. HOOD HOOK BRACKET (2)               | 9. NEGATIVE BATTERY POWER CABLE (BATTERY-TO-RECEPTACLE)     |
| 3. HOOD HOOK (2)                       | 10. NEGATIVE BATTERY POWER CABLE                            |
| 4. BATTERY BOX                         | 11. NEGATIVE BATTERY POWER CABLE (BATTERY-TO-STARTER MOTOR) |
| 5. NUT (3)                             | 12. STE/ICE NEGATIVE POWER CABLE                            |
| 6. ENGINE HARNESS 12-VOLT SUPPLY CABLE |   |
| 7. POSITIVE BATTERY POWER CABLE        |   |

TA 237324

ELECTRICAL SYSTEM.

**3-120. BATTERY POWER DISCONNECT AND CONNECT PROCEDURE (Continued).**

LOCATION/ITEM	ACTION	REMARKS
---------------	--------	---------

**D. CONNECT (Continued).**

- |                      |  |  |
|----------------------|--|--|
| <p>7. Cover (1).</p> | <ul style="list-style-type: none"> <li>a. Line up two pins on item (1) with holes in item (4).</li> <li>b. Push item (1) in and lower onto item (4).</li> <li>c. Secure with two items (9).</li> </ul> |  |
|----------------------|--|--|

**NOTE**

**Follow-on maintenance action required:**

**Reset tachograph clock (para 3-309).**

ELECTRICAL SYSTEM.

3-120. BATTERY POWER DISCONNECT AND CONNECT PROCEDURE (Continued).

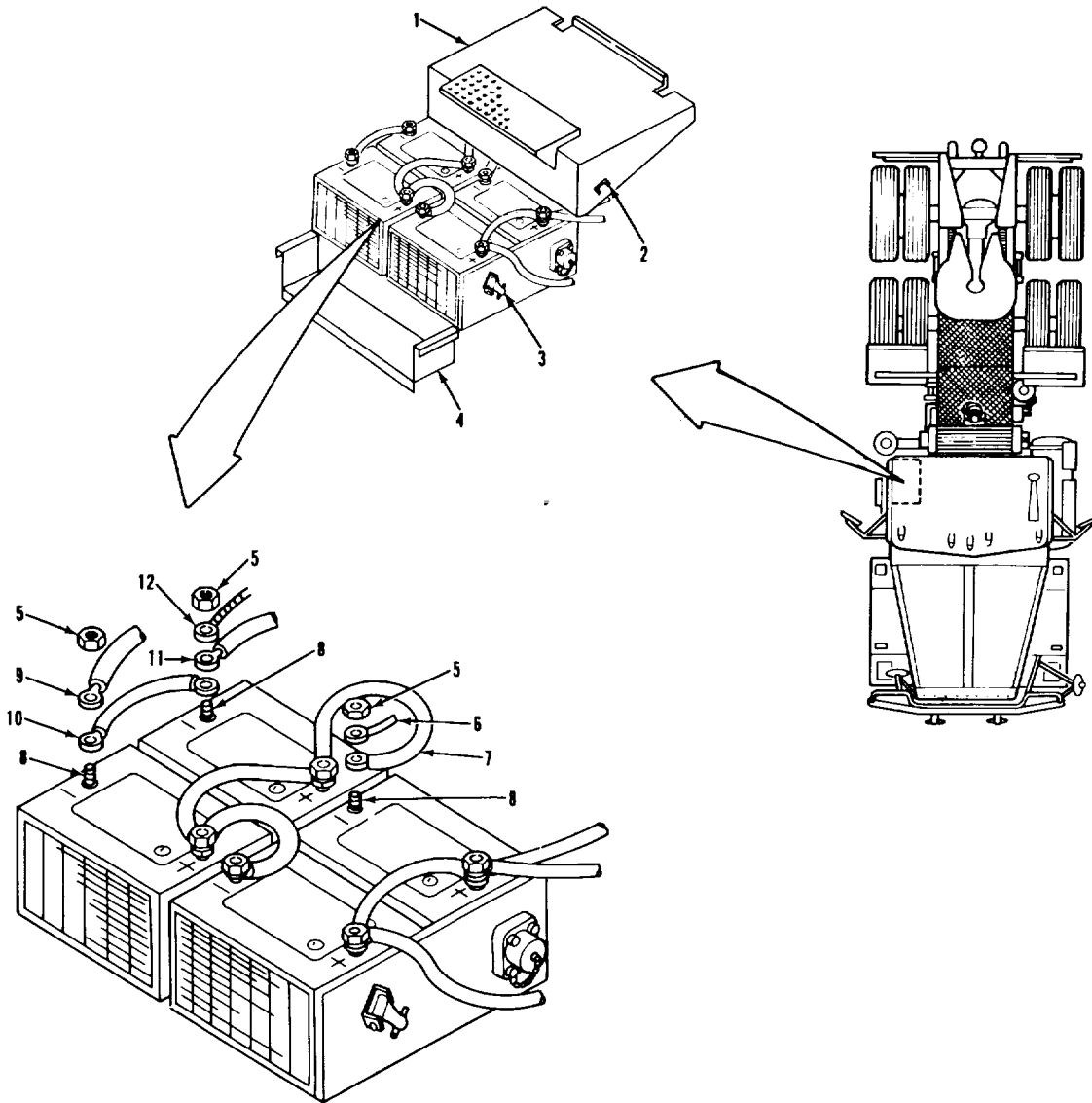

LEGEND:

- |  |  |
|--|--|
| 1. BATTERY BOX COVER                   | 8. TERMINAL (3)  |
| 2. HOOD HOOK BRACKET (2)               | 9. NEGATIVE BATTERY POWER CABLE<br>(BATTERY-TO-RECEPTACLE)     |
| 3. HOOD HOOK (2)                       | 10. NEGATIVE BATTERY POWER CABLE                               |
| 4. BATTERY BOX                         | 11. NEGATIVE BATTERY POWER CABLE<br>(BATTERY-TO-STARTER MOTOR) |
| 5. NUT (3)                             | 12. STE/ICE NEGATIVE POWER CABLE                               |
| 6. ENGINE HARNESS 12-VOLT SUPPLY CABLE |  |
| 7. POSITIVE BATTERY POWER CABLE        |  |

TA 237325

**ELECTRICAL SYSTEM.**

**3-121. BATTERY REPLACEMENT.**

THIS TASK COVERS

- a. Removal.
- b. Cleaning.
- c. Inspection.
- d. Installation.

INITIAL SETUP

APPLICABLE CONFIGURATIONS

All.

EQUIPMENT CONDITION  
PARAGRAPH

None.

CONDITION DESCRIPTION

None.

TEST EQUIPMENT

None.

SPECIAL TOOLS

None.

MATERIALS/PARTS (P/N)

Sodium bicarbonate (baking soda)  
Item 27, Appendix C.

PERSONNEL REQUIRED

One (MOS-63S).

SPECIAL ENVIRONMENTAL CONDITIONS

None.

REFERENCES (TM)

None.

GENERAL SAFETY INSTRUCTIONS

Engine off.  
Transmission in neutral.  
Park brake set.  
Wear safety goggles.

TROUBLESHOOTING REFERENCES

Paragraph 2-11.

ELECTRICAL SYSTEM.

3-121. BATTERY REPLACEMENT (Continued).

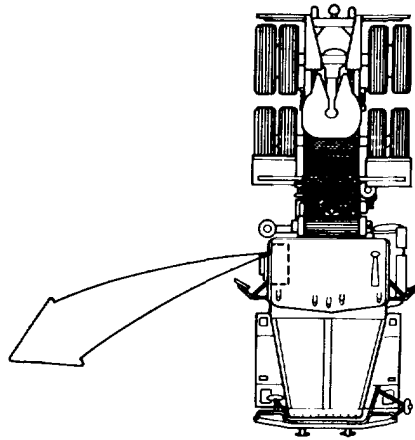
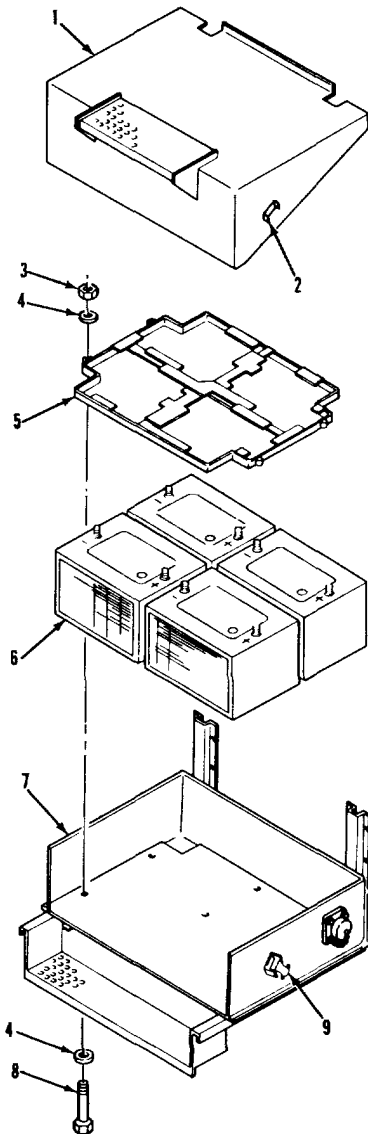

FRONT  
OF VEHICLE



LEGEND:

- 1. BATTERY BOX COVER
- 2. HOOD HOOK BRACKET (2)
- 3. HEXAGON NUT (5)
- 4. WASHER (10)
- 5. BATTERY HOLDDOWN

- 6. BATTERY (4)
- 7. BATTERY BOX
- 8. HEXAGON BOLT (5)
- 9. HOOD HOOK

TA 237226

**ELECTRICAL SYSTEM.**

**3-121. BATTERY REPLACEMENT (Continued).**

LOCATION/ITEM	ACTION	REMARKS
<b><u>A. REMOVAL.</u></b>		
1. Two hooks (9)	a. Remove from two items (2). b. Lift item (1) from item (7).	
<b>NOTE</b>		
Skip step 2 if cables are already removed.		
2. Battery cables	Remove from battery	Refer to paragraph 3-124.
3. Five nuts (3), ten washers (4), and five bolts (8).	Remove from item (5) and (7).	
4. Holddown (5)	Remove from item (6).	
5. Batteries (6) (as necessary).	Remove from item (7).	
<b><u>B. CLEANING.</u></b>		
6. Batteries (6) and holddown (5)	a. Clean with water and sodium bicarbonate. b. Rinse with clear water and dry thoroughly with clean, dry rags.	
<b><u>C. INSPECTION.</u></b>		
7. Batteries (6)	a. Inspect for cracks and breaks that allow electrolyte to leak. b. Inspect test indicator for green, dark, or yellow condition (para 3-119).	Replace if leaking.  Batteries are good in green condition Charge batteries in dark con-
Replace batteries in yellow condition		
<b>3-704</b>		



**ELECTRICAL SYSTEM.**

**3-121. BATTERY REPLACEMENT (Continued)**

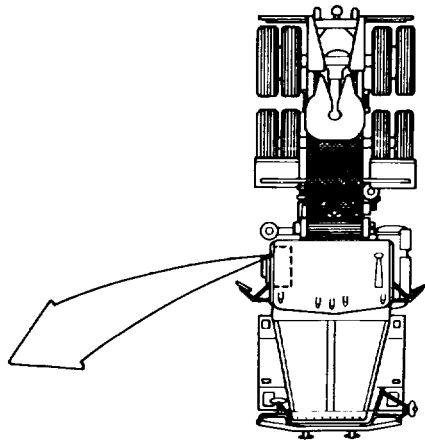
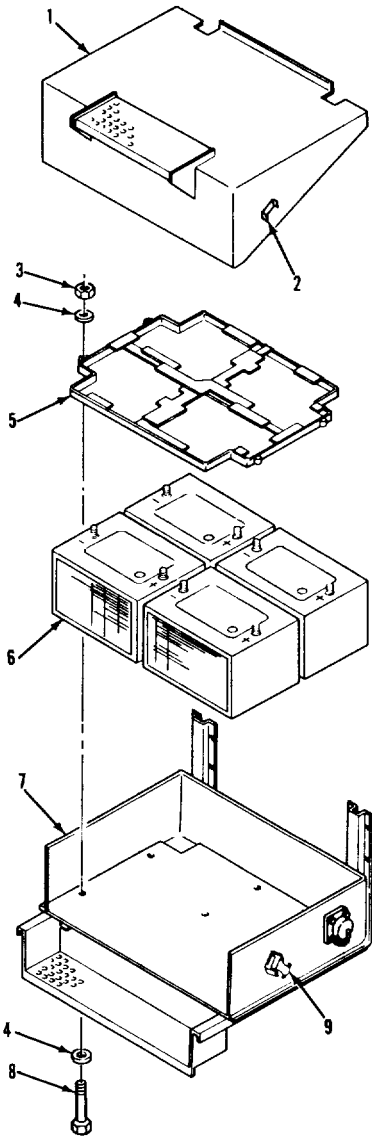

FRONT  
OF VEHICLE



**LEGEND:**

- 1. BATTERY BOX COVER
- 2. HOOD HOOK BRACKET (2)
- 3. HEXAGON NUT (5)
- 4. WASHER (10)
- 5. BATTERY HOLDDOWN

- 6. BATTERY (4)
- 7. BATTERY BOX
- 8. HEXAGON BOLT (5)
- 9. HOOD HOOK

TA 237327

ELECTRICAL SYSTEM.

3-121. BATTERY REPLACEMENT (Continued).		
LOCATION/ITEM	ACTION	REMARKS
<b>C. INSPECTION (Continued).</b>		
8. All metal parts	Inspect	Refer to paragraph 3-5.
<b>D. INSTALLATION.</b>		
<b>NOTE</b>		
Position batteries in vehicle with positive (+) terminals toward front of vehicle.		
9. Batteries (6)	Install in item (7).	
10. Holddown (5)	a. Position on item (6). b. Secure with five items (8), ten items (4), and five items (3).	
11. Battery cables	Install	Refer to paragraph 3-124.
12. Cover (1)	a. Line up two pins on item (1) with holes in item (4). b. Push item (1) in and lower onto item (4). c. Secure with two items (9).	
<b>NOTE</b>		
Follow-on maintenance action required: None.		
<b>3-706</b>		

**ELECTRICAL SYSTEM.**

**3-121. BATTERY REPLACEMENT (Continued)**

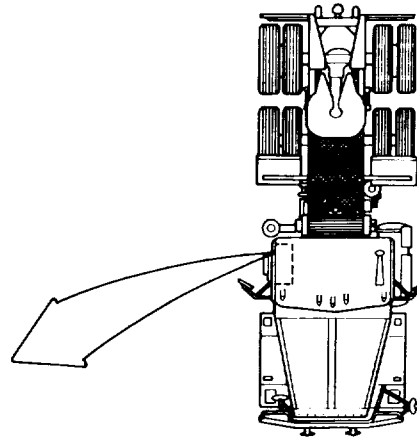
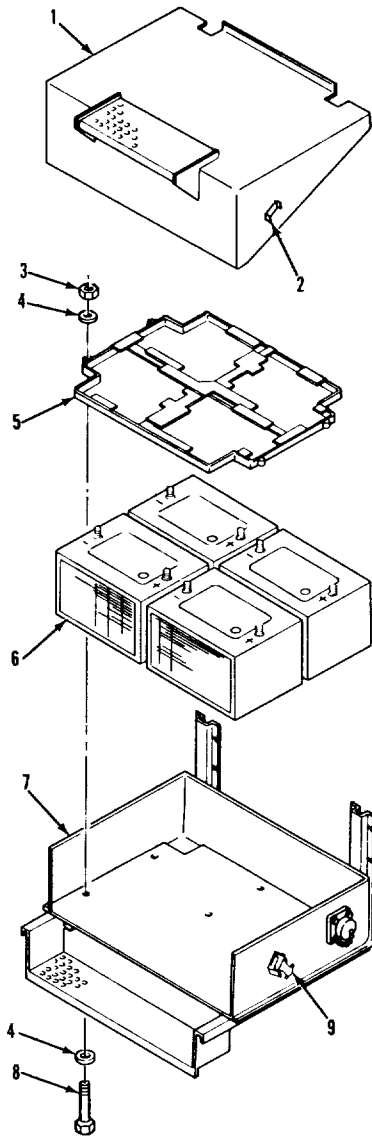

FRONT  
OF VEHICLE



**LEGEND:**

- 1. BATTERY BOX COVER
- 2. HOOD HOOK BRACKET (2)
- 3. HEXAGON NUT (5)
- 4. WASHER (10)
- 5. BATTERY HOLDDOWN

- 6. BATTERY (4)
- 7. BATTERY BOX
- 8. HEXAGON BOLT (5)
- 9. HOOD HOOK

TA 237328

**ELECTRICAL SYSTEM.  
3-122. BATTERY BOX REPLACEMENT.**

**This task covers:**

- 
- a. Removal
  - b. Cleaning
  - c. Installation
- 

**INITIAL SETUP:**

<u><b>APPLICABLE CONFIGURATIONS</b></u>	<u><b>EQUIPMENT CONDITION PARAGRAPH</b></u>	<u><b>CONDITION DESCRIPTION</b></u>
All removed.	3-170	Secondary reservoir
<u><b>TEST EQUIPMENT</b></u> None. 3-125 Slave start receptacle removed.	3-121	Batteries removed.
<u><b>SPECIAL TOOLS</b></u> None 3-123 Battery box latch removed.		
<u><b>MATERIALS/PARTS (P/N)</b></u> Sodium bicarbonate (baking soda) Item 27, Appendix C. Black acidproof paint Item 4, Appendix C.		
<u><b>PERSONNEL REQUIRED</b></u> Two (MOS-63S	<u><b>SPECIAL ENVIRONMENTAL CONDITIONS</b></u> None.	
<u><b>REFERENCES (TM)</b></u> None Engine off. Transmission in neutral. Park brake set.	<u><b>GENERAL SAFETY INSTRUCTIONS</b></u>	
<u><b>TROUBLESHOOTING REFERENCES</b></u> Paragraph 2-11.		

**ELECTRICAL SYSTEM.**

**3-122. BATTERY BOX REPLACEMENT (Continued).**

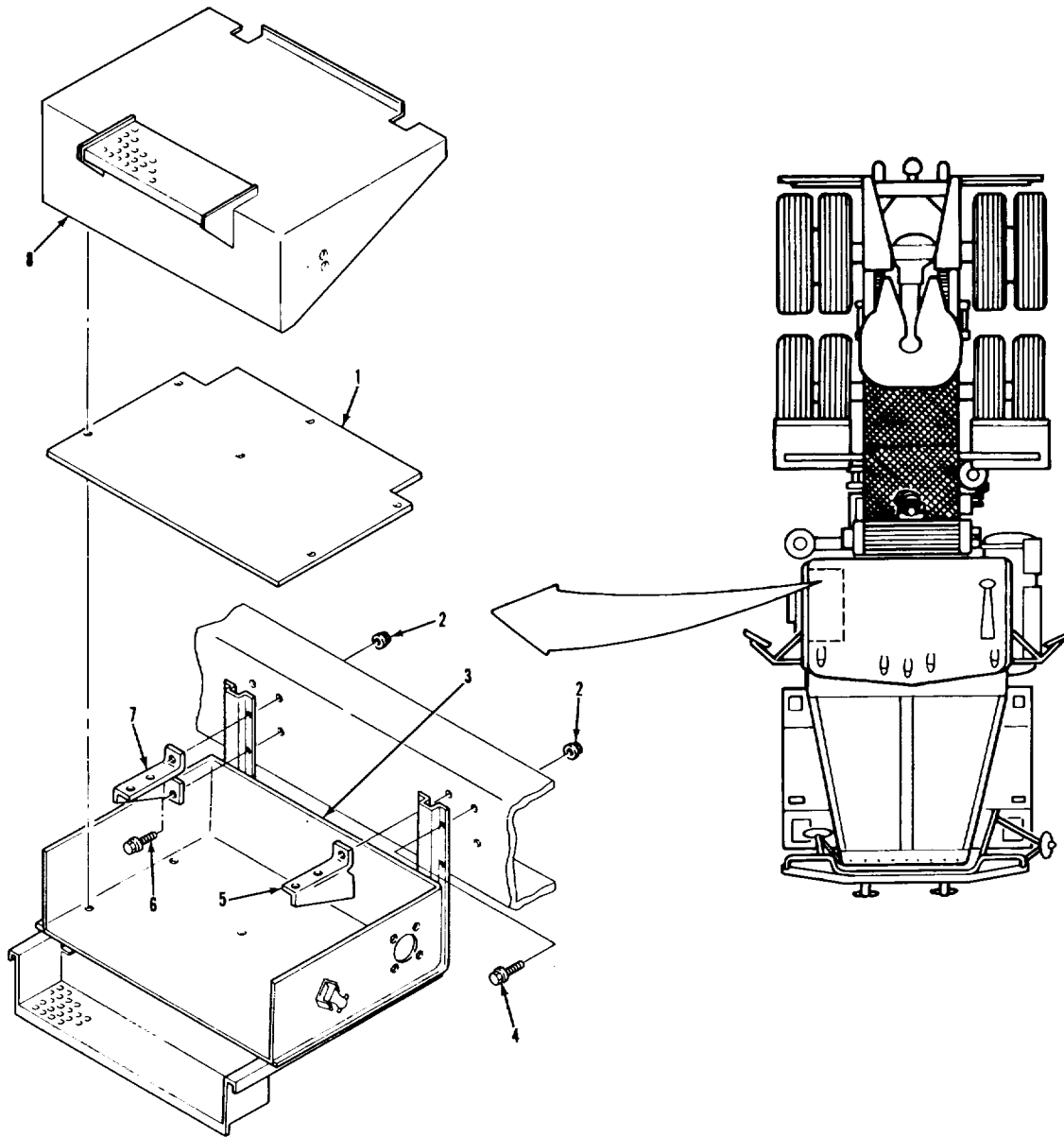

**LEGEND:**

- 1. BATTERY BOX TRAY SPACER
- 2. HEXAGON FLANGE NUT (8)
- 3. BATTERY BOX ASSEMBLY
- 4. SCREW (4)

- 5. FRONT AIR TANK SUPPORT
- 6. HEXAGON FLANGE BOLT (4)
- 7. REAR AIR TANK SUPPORT
- 8. BATTERY BOX COVER

TA 23732

**ELECTRICAL SYSTEM.**

**3-122. BATTERY BOX REPLACEMENT (Continued).**

LOCATION/ITEM	ACTION	REMARKS
<b><u>A. REMOVAL.</u></b>		
1. Spacer (1)	Remove from item (3).	
2. Four bolts (6) and nuts (2)	Remove from item (5), item (7), and item (3).	
3. Four screws (4) and nuts (2)	Remove from item (3) (3).	Assistant supports item
<b><u>B. CLEANING.</u></b>		
4. Box assembly (3), cover (8), and spacer (1).	a. Wash with water and sodium bicarbonate.	
	b. Clean with a wire brush.	
	c. Paint inside of item (3) and item (8) and all of item (1) with black acid-proof paint.	
<b><u>C. INSTALLATION.</u></b>		
5. Box assembly (3)	Put in place on frame	Assistant holds in place.
6. Four screws (4) and nuts (2).	Secure item (3) to frame.	
7. Four bolts (6) and nuts (2)	Secure item (5) and item (7) to item (3) and frame.	
8. Spacer (1)	Install in item (3).	
<b>NOTE</b>		
<b>Follow-on maintenance action required:</b>		
<b>Install battery box latch (para 3-123).</b>		
<b>Install slave start receptacle (para 3-125).</b>		
<b>Install batteries (para 3-121).</b>		
<b>Install secondary reservoir (para 3-170).</b>		
<b>3-710</b>		

**ELECTRICAL SYSTEM.**

**3-122. BATTERY BOX REPLACEMENT (Continued).**

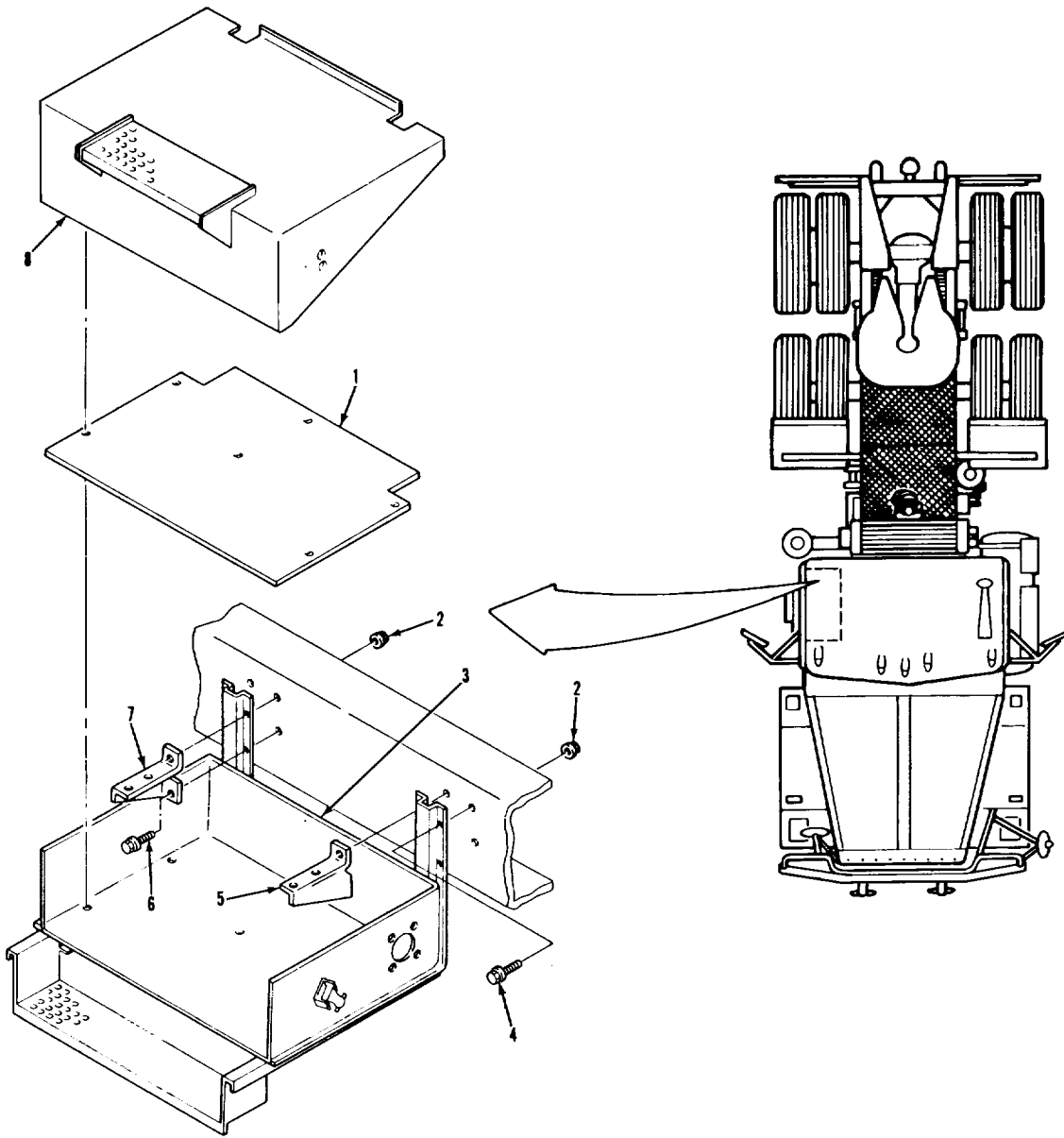

**LEGEND:**

- 1. BATTERY BOX TRAY SPACER
- 2. HEXAGON FLANGE NUT (8)
- 3. BATTERY BOX ASSEMBLY
- 4. SCREW (4)

- 5. FRONT AIR TANK SUPPORT
- 6. HEXAGON FLANGE BOLT (4)
- 7. REAR AIR TANK SUPPORT
- 8. BATTERY BOX COVER

TA 237329

**ELECTRICAL SYSTEM.**

**3-123. BATTERY BOX LATCH REPLACEMENT.**

**This task covers:**

- 
- a. Removal
  - b. Cleaning
  - c. Installation
- 

**INITIAL SETUP:**

**APPLICABLE CONFIGURATIONS**

All

**EQUIPMENT CONDITIONS**

**PARAGRAPH**

TM 9-2320-283-10

**CONDITION DESCRIPTION**

Battery box cover removed.

**TEST EQUIPMENT**

None.

**SPECIAL TOOLS**

None.

**MATERIALS/PARTS (P/N)**

Pin, cotter  
(24617) 453689.

**PERSONNEL REQUIRED**

One (MOS-63S)

**REFERENCES (TM)**

TM 9-2320-283-10  
TM 9-2320-283-20P  
Park brake set.

**TROUBLESHOOTING REFERENCES**

Paragraph 2-11.

**SPECIAL ENVIRONMENTAL CONDITIONS**

None.

**GENERAL SAFETY INSTRUCTIONS**

Engine off.  
Transmission in neutral.



ELECTRICAL SYSTEM.

3-123. BATTERY BOX LATCH REPLACEMENT (Continued)

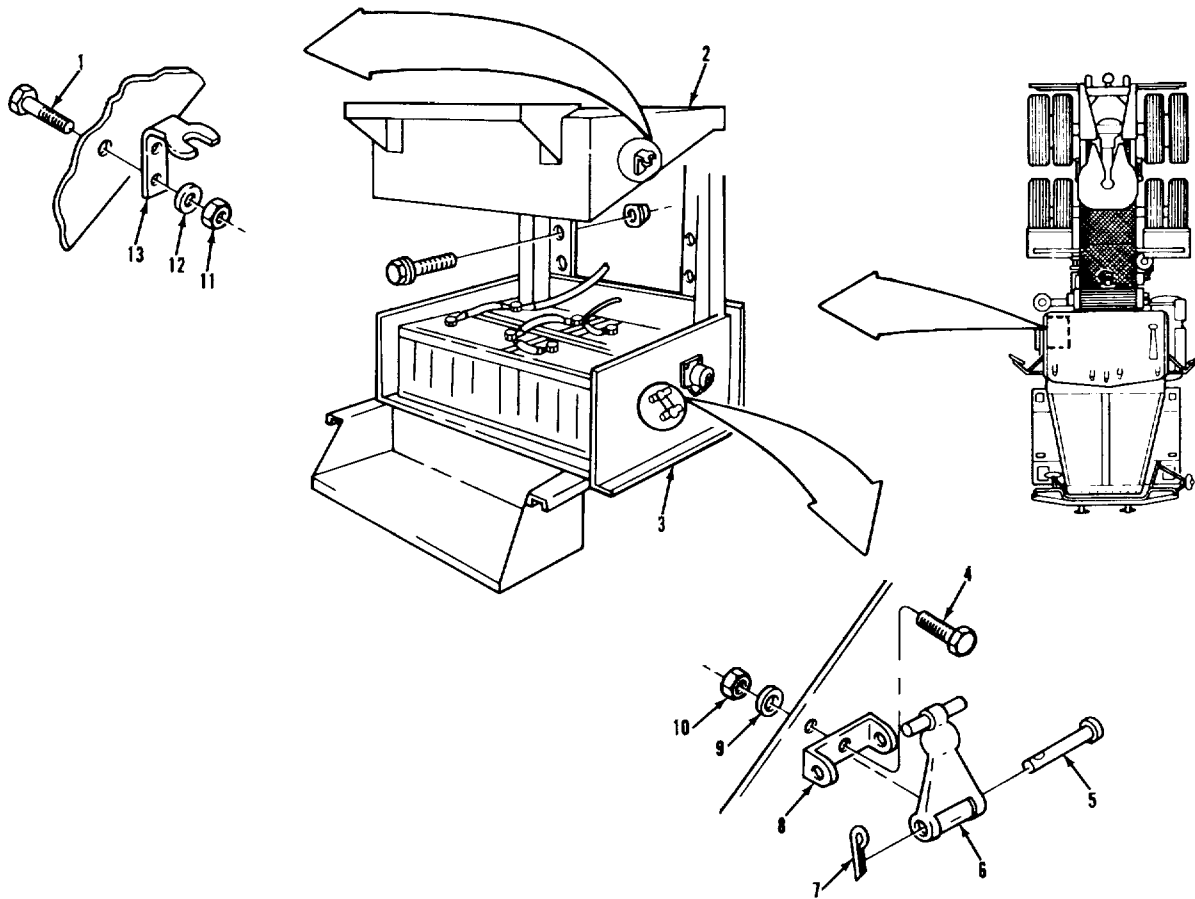

LEGEND:

- |                               |                             |
|-------------------------------|-----------------------------|
| 1. SCREW (2)                  | 8. HOOD HOOK ANCHOR BRACKET |
| 2. BATTERY BOX COVER ASSEMBLY | 9. FLAT WASHER              |
| 3. BATTERY BOX ASSEMBLY       | 10. HEX NUT                 |
| 4. SCREW                      | 11. NUT (2)                 |
| 5. HOOD HOOK ANCHOR PIN       | 12. FLAT WASHER (2)         |
| 6. HOOD HOOK                  | 13. HOOD HOOK BRACKET       |
| 7. COTTER PIN                 |                             |

TA 237331

**ELECTRICAL SYSTEM.**

**3-123. BATTERY BOX LATCH REPLACEMENT (Continued).**

LOCATION/ITEM	ACTION	REMARKS
<b>NOTE</b>		
<b>Replacement is the same for both latches.</b>		
<b><u>A. REMOVAL.</u></b>		
1. Cotter pin (7)	Remove from item (5)	Discard item (7).
2. Pin (5)	Remove from item (8) and item (6).	
3. Screw (4), washer (9), and nut (10)	Remove from item (8) and item (3).	
4. Two screws (1), washers (12), and nuts (11).	Remove from item (13) and item (2).	
<b><u>B. INSTALLATION.</u></b>		
5. Two screws (1), washers (12), and nuts (11).	Secure item (13) to item (2).	
6. Screw (4), washer (9), and nut (10).	Secure item (8) to item (3).	
7. Hook (6)	Put in place in item (8).	
8. Pin (5)	Install in item (8) and item (6).	
9. New cotter pin (7).	Install in item (5).	
<b>NOTE</b>		
Follow-on maintenance action required: Install battery box cover (TM 9-2320-283-10).		
<b>3-714</b>		

**ELECTRICAL SYSTEM.**

**3-123. BATTERY BOX LATCH REPLACEMENT (Continued).**

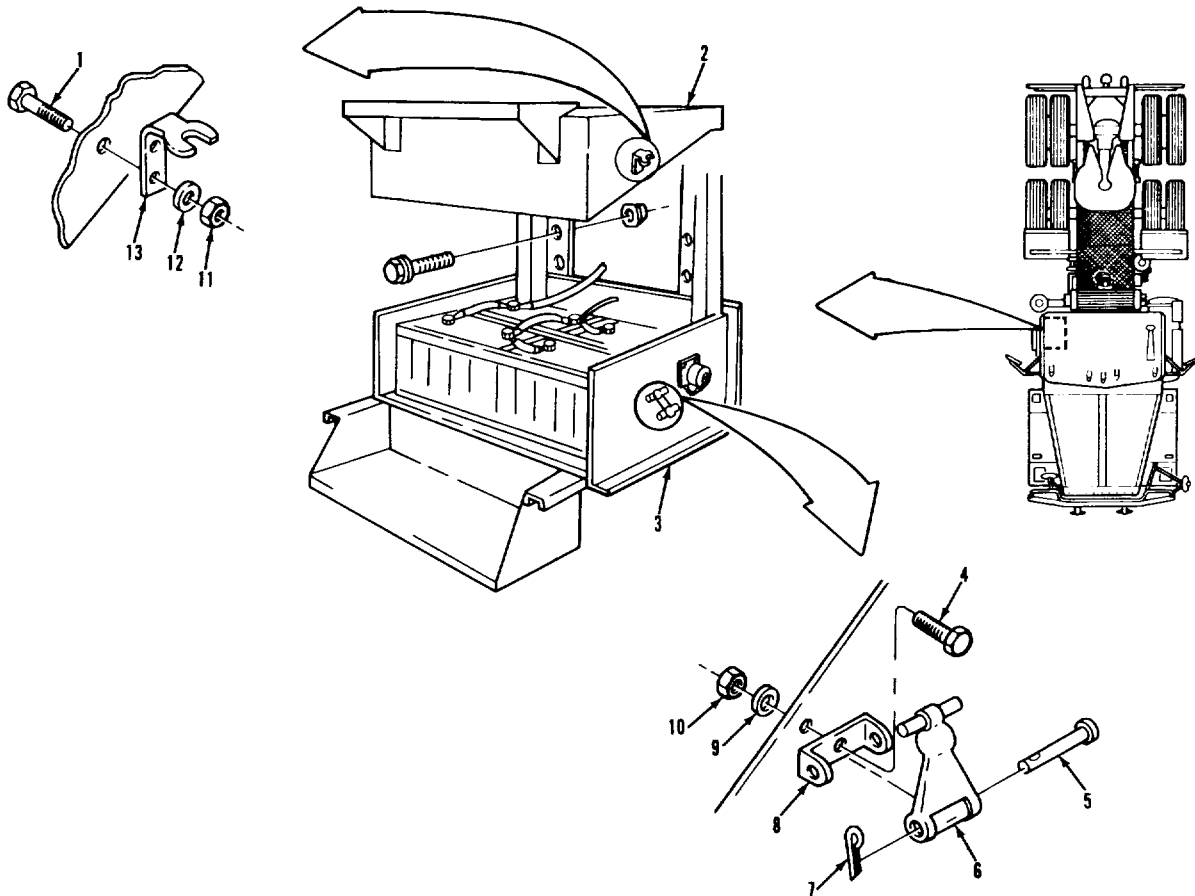

**LEGEND:**

- |                               |                             |
|-------------------------------|-----------------------------|
| 1. SCREW (2)                  | 8. HOOD HOOK ANCHOR BRACKET |
| 2. BATTERY BOX COVER ASSEMBLY | 9. FLAT WASHER              |
| 3. BATTERY BOX ASSEMBLY       | 10. HEX NUT                 |
| 4. SCREW                      | 11. NUT (2)                 |
| 5. HOOD HOOK ANCHOR PIN       | 12. FLAT WASHER (2)         |
| 6. HOOD HOOK                  | 13. HOOD HOOK BRACKET       |
| 7. COTTER PIN                 |                             |

TA 237332

**ELECTRICAL SYSTEM.**

**3-124. BATTERY CABLE REPLACEMENT.**

**THIS TASK COVERS**

- a. Battery Cable Removal.
- b. Battery Cable Installation.
- c. Positive Battery Power Cable (Battery-to-Starter Motor) Replacement.
- d. Negative Battery Power Cable (Battery-to-Starter Motor) Replacement.
- e. Positive Battery Power Cable (Battery-to-Receptacle) Replacement.
- f. Negative Battery Power Cable (Battery-to-Receptacle) Replacement.
- g. Positive Battery Power Cable (Battery A-to-Battery B) Replacement.
- h. Positive Battery Power Cable (Battery A-to-Battery C) Replacement.
- i. Positive Battery Power Cable (Battery C-to-Battery D) Replacement.
- j. Positive Battery Power Cable (Battery B-to-Battery D) Replacement.
- k. Negative Battery Power Cable (Battery D-to-Battery C) Replacement.
- l. Cleaning and Inspecting Cables.

**INITIAL SETUP**

**APPLICABLE CONFIGURATIONS**

All

**EQUIPMENT CONDITION**

**PARAGRAPH**

TM 9-2320-283-10

**CONDITION DESCRIPTION**

Battery box cover removed

**TEST EQUIPMENT**

None.

**SPECIAL TOOLS**

None.

**MATERIALS/PARTS (P/N)**

Grease, automotive and artillery  
 Item 7, Appendix C.  
 Rag, wiping  
 Item 22, Appendix C.  
 Sodium bicarbonate (baking soda)  
 Item 27, Appendix C.

**PERSONNEL REQUIRED**

One (MOS-63S)

**SPECIAL ENVIRONMENTAL CONDITIONS**

None.

**REFERENCES (TM)**

None

**GENERAL SAFETY INSTRUCTIONS**

Engine off.  
 Transmission in neutral.  
 Park brake set.  
 Wear safety goggles.

**TROUBLESHOOTING REFERENCES**

Paragraph 2-11

ELECTRICAL SYSTEM.

3-124. BATTERY CABLE REPLACEMENT (Continued).

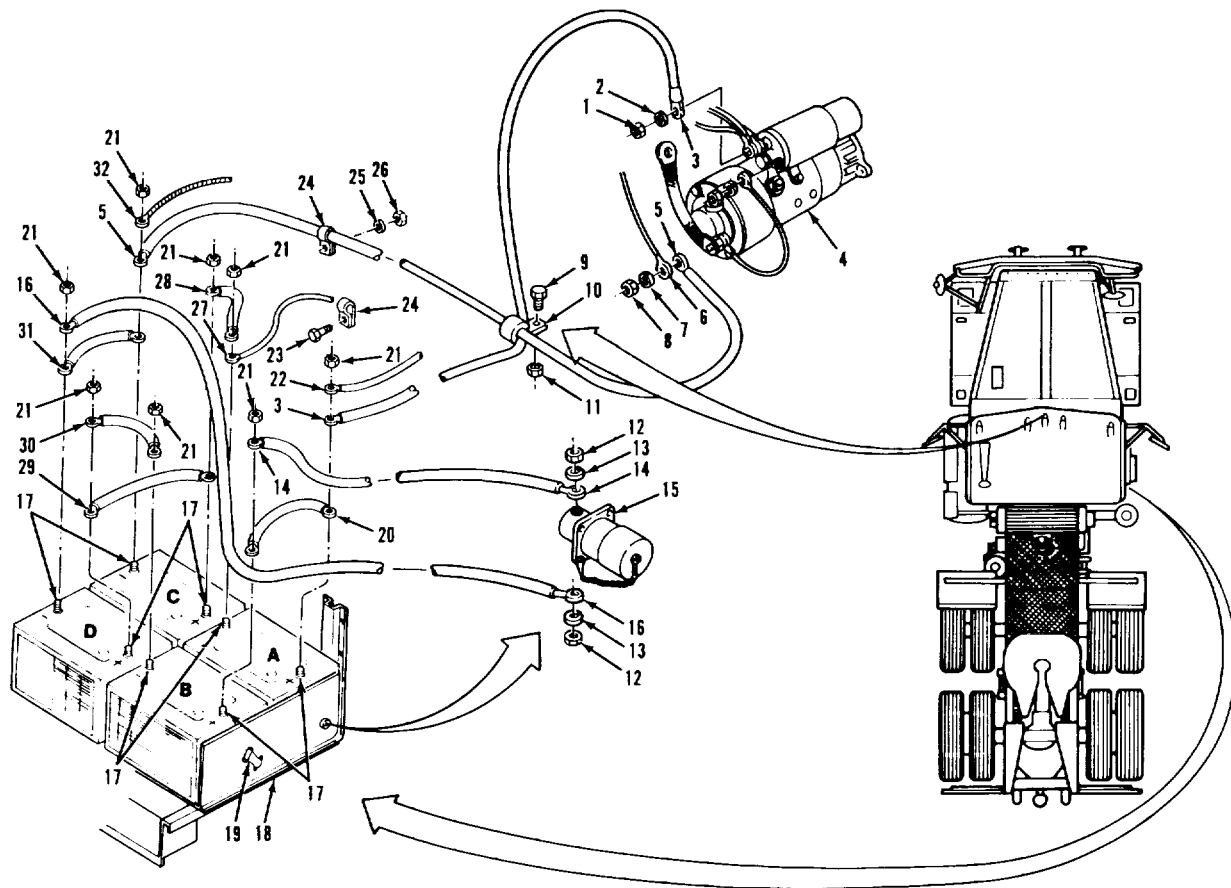

LEGEND:

- |                       |                       |                        |
|-----------------------|-----------------------|------------------------|
| 1. HEXAGON NUT        | 14. POSITIVE BATTERY  | 25. LOCKWASHER         |
| 2. LOCKWASHER         | POWER CABLE (BATTERY- | 26. NUT                |
| 3. POSITIVE BATTERY   | TO-RECEPTACLE)        | 27. ENGINE HARNESS 12- |
| POWER CABLE (BATTERY- | 15. RECEPTACLE        | VOLT SUPPLY CABLE      |
| TO-STARTER MOTOR)     | 16. NEGATIVE BATTERY  | 28. POSITIVE BATTERY   |
| 4. STARTER MOTOR      | POWER CABLE (BATTERY- | POWER CABLE (BATTERY   |
| 5. NEGATIVE BATTERY   | TO-RECEPTACLE)        | A-TO-BATTERY C)        |
| POWER CABLE (BATTERY- | 17. TERMINALS (8)     | 29. POSITIVE BATTERY   |
| TO-STARTER MOTOR)     | 18. BATTERY BOX       | POWER CABLE (BATTERY   |
| 6. WIRE (98K)         | 19. HOOD HOOK (2)     | C-TO-BATTERY D)        |
| 7. LOCKWASHER         | 20. POSITIVE BATTERY  | 30. POSITIVE BATTERY   |
| 8. HEXAGON NUT        | POWER CABLE (BATTERY  | POWER CABLE (BATTERY   |
| 9. SCREW              | A-TO-BATTERY B)       | B-TO-BATTERY D)        |
| 10. CUSHION CLAMP     | 21. NUT (8)           | 31. NEGATIVE BATTERY   |
| 11. HEXAGON NUT       | 22. STE/ICE POSITIVE  | POWER CABLE (BATTERY   |
| 12. SCREW (2)         | POWER CABLE           | D-TO-BATTERY C)        |
| 13. WASHER (2)        | 23. HEXAGON BOLT      | 32. STE/ICE NEGATIVE   |
|                       | 24. CLAMP (2)         | POWER CABLE            |

TA 237333

**ELECTRICAL SYSTEM.**

**3-124. BATTERY CABLE REPLACEMENT (Continued).**

LOCATION/ITEM	ACTION	REMARKS
<p style="text-align: center;"><b><u>WARNING</u></b></p> <p>Always remove negative battery ground cables first or install them last to avoid sparks that can cause an explosion Failure to follow this precaution may result in serious injury to you and other personnel.</p> <p style="text-align: center;"><b><u>CAUTION</u></b></p> <p>Make sure batteries are connected in series-parallel Failure to properly connect batteries can result in severe damage to vehicle electrical system.</p> <p style="text-align: center;"><b><u>NOTE</u></b></p> <p>Use general shop practices when removing and installing cable ties Cable ties are to be used as needed for securing battery cables.</p>		
<p><b><u>A. BATTERY CABLE REMOVAL.</u></b></p>		
<p>1. Nut (21) and cables (32), (5), and (31).</p>	<p>Remove from item (17)</p>	<p>Tag for identification.</p>
<p>2. Nut (21) and cables (31) and (16).</p>	<p>Remove from item (17)</p>	<p>Tag for identification.</p>
<p>3. Nut (21) and cables (27) and (28).</p>	<p>Remove from item (17)</p>	<p>Tag for identification.</p>
<p>4. Nut (21) and cables (29) and (30).</p>	<p>Remove from item (17)</p>	<p>Tag for identification.</p>
<p>5. Nut (21) and cables (28) and (29).</p>	<p>Remove from item (17)</p>	<p>Tag for identification.</p>
<p>6. Nut (21) and cable (30).</p>	<p>Remove from item (17)</p>	<p>Tag for identification.</p>
<p><b>3-718</b></p>		

ELECTRICAL SYSTEM.

3-124. BATTERY CABLE REPLACEMENT (Continued).

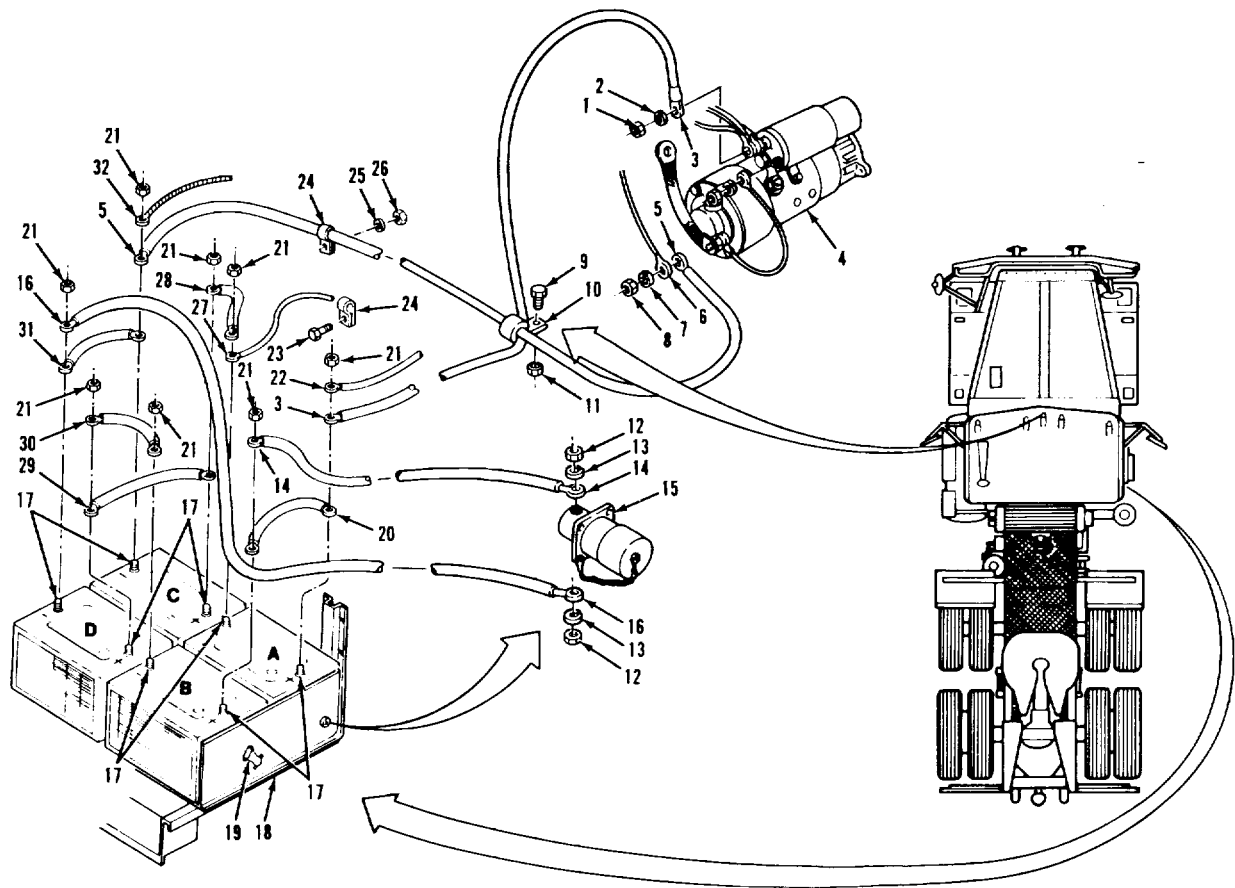

LEGEND:

- |  |   |   |
|--|---|---|
| 1. HEXAGON NUT   | 14. POSITIVE BATTERY POWER CABLE (BATTERY-TO-RECEPTACLE)  | 25. LOCKWASHER  |
| 2. LOCKWASHER  | 15. RECEPTACLE  | 26. NUT   |
| 3. POSITIVE BATTERY POWER CABLE (BATTERY-TO-STARTER MOTOR) | 16. NEGATIVE BATTERY POWER CABLE (BATTERY-TO-RECEPTACLE)  | 27. ENGINE HARNESS 12-VOLT SUPPLY CABLE                   |
| 4. STARTER MOTOR   | 17. TERMINALS (8)   | 28. POSITIVE BATTERY POWER CABLE (BATTERY A-TO-BATTERY C) |
| 5. NEGATIVE BATTERY POWER CABLE (BATTERY-TO-STARTER MOTOR) | 18. BATTERY BOX   | 29. POSITIVE BATTERY POWER CABLE (BATTERY C-TO-BATTERY D) |
| 6. WIRE (98K)  | 19. HOOD HOOK (2)   | 30. POSITIVE BATTERY POWER CABLE (BATTERY B-TO-BATTERY D) |
| 7. LOCKWASHER  | 20. POSITIVE BATTERY POWER CABLE (BATTERY A-TO-BATTERY B) | 31. NEGATIVE BATTERY POWER CABLE (BATTERY D-TO-BATTERY C) |
| 8. HEXAGON NUT   | 21. NUT (8)   | 32. STE/ICE NEGATIVE POWER CABLE                          |
| 9. SCREW   | 22. STE/ICE POSITIVE POWER CABLE                          |   |
| 10. CUSHION CLAMP  | 23. HEXAGON BOLT  |   |
| 11. HEXAGON NUT  | 24. CLAMP (2)   |   |
| 12. SCREW (2)  |   |   |
| 13. WASHER (2)   |   |   |

TA 237334

**ELECTRICAL SYSTEM.**

**3-124. BATTERY CABLE REPLACEMENT (Continued).**

LOCATION/ITEM	ACTION	REMARKS
<b><u>A. BATTERY CABLE REMOVAL (Continued).</u></b>		
7. Nut (21) and cables (20) and (14).	Remove from item (17)	Tag for identification.
8. Nut (21) and cables (20), (3), and (22).	Remove from item (17)	Tag for identification.
<b><u>B. BATTERY CABLE INSTALLATION.</u></b>		
9. Cables (22), (20), and (3).	a. Position on item (17).	
	b. Secure with item (21).	
	c. Lubricate with grease.	
10. Cables (14) and (20).	a. Position on item (17).	
	b. Secure with item (21).	
	c. Lubricate with grease.	
11. Cable (30)	a. Position on item (17).	
	b. Secure with item (21).	
	c. Lubricate with grease.	
12. Cables (28) and (29).	a. Position on item (17).	
	b. Secure with item (21).	
	c. Lubricate with grease.	
13. Cables (30) and (29).	a. Position on item (17).	
	b. Secure with item (21).	
	c. Lubricate with grease.	
14. Cables (28) and (27).	a. Position on item (17).	
	b. Secure with item (21).	
	c. Lubricate with grease.	



ELECTRICAL SYSTEM.

3-124. BATTERY CABLE REPLACEMENT (Continued).

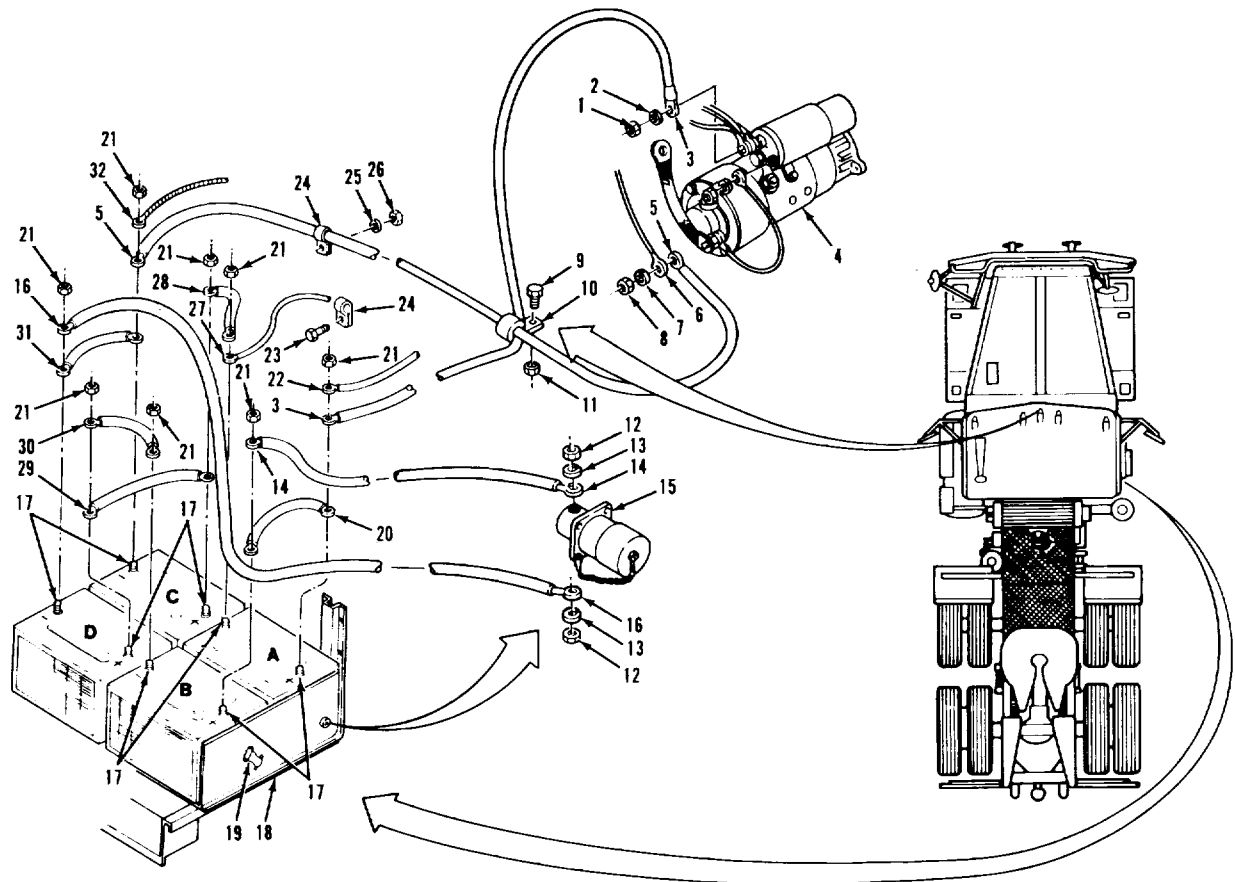

LEGEND:

- |   |   |   |
|---|---|---|
| 1. HEXAGON NUT  | 14. POSITIVE BATTERY<br>POWER CABLE (BATTERY-<br>TO-RECEPTACLE) | 25. LOCKWASHER  |
| 2. LOCKWASHER   | 15. RECEPTACLE  | 26. NUT   |
| 3. POSITIVE BATTERY<br>POWER CABLE (BATTERY-<br>TO-STARTER MOTOR) | 16. NEGATIVE BATTERY<br>POWER CABLE (BATTERY-<br>TO-RECEPTACLE) | 27. ENGINE HARNESS 12-<br>VOLT SUPPLY CABLE                     |
| 4. STARTER MOTOR  | 17. TERMINALS (8)   | 28. POSITIVE BATTERY<br>POWER CABLE (BATTERY<br>A-TO-BATTERY C) |
| 5. NEGATIVE BATTERY<br>POWER CABLE (BATTERY-<br>TO-STARTER MOTOR) | 18. BATTERY BOX   | 29. POSITIVE BATTERY<br>POWER CABLE (BATTERY<br>C-TO-BATTERY D) |
| 6. WIRE (98K)   | 19. HOOD HOOK (2)   | 30. POSITIVE BATTERY<br>POWER CABLE (BATTERY<br>B-TO-BATTERY D) |
| 7. LOCKWASHER   | 20. POSITIVE BATTERY<br>POWER CABLE (BATTERY<br>A-TO-BATTERY B) | 31. NEGATIVE BATTERY<br>POWER CABLE (BATTERY<br>D-TO-BATTERY C) |
| 8. HEXAGON NUT  | 21. NUT (8)   | 32. STE/ICE NEGATIVE<br>POWER CABLE                             |
| 9. SCREW  | 22. STE/ICE POSITIVE<br>POWER CABLE                             |   |
| 10. CUSHION CLAMP   | 23. HEXAGON BOLT  |   |
| 11. HEXAGON NUT   | 24. CLAMP (2)   |   |
| 12. SCREW (2)   |   |   |
| 13. WASHER (2)  |   |   |

TA 237335

**ELECTRICAL SYSTEM.**

**3-124. BATTERY CABLE REPLACEMENT (Continued).**

LOCATION/ITEM	ACTION	REMARKS
<b><u>B. BATTERY CABLE INSTALLATION (Continued).</u></b>		
15. Cables (16) and (31).	a. Position on item (17). b. Secure with item (21). c. Lubricate with grease.	
16. Cables (31), (5), and (32).	a. Position on item (17). b. Secure with item (21). c. Lubricate with grease.	
<b><u>C. POSITIVE BATTERY POWER CABLE (BATTERY-TO-STARTER MOTOR) REPLACEMENT.</u></b>		
17. Ground cables	Disconnect from batteries	Refer to paragraph 3-120.
18. Nut (21) and cables (22) and (3).	Remove from item (17)	Tag for identification.
19. Screw (9), clamp (10), and nut (11)	Remove from item (3), item (5), and transmission.	
20. Nut (1), lockwasher (2), and cable (3).	Remove from item (4).	
21. Cable (3)	a. Position on item (4). b. Secure with items (1) and (2).	
22. Cables (3) and (5)	a. Position in item (10). b. Secure item (10) to transmission with items (9) and (11). c. Lubricate with grease.	
23. Cables (3) and (22)	a. Position on item (17). b. Secure with item (21). c. Lubricate with grease.	
24. Ground cables	Connect to batteries	Refer to paragraph 3-120.

ELECTRICAL SYSTEM.

3-124. BATTERY CABLE REPLACEMENT (Continued).

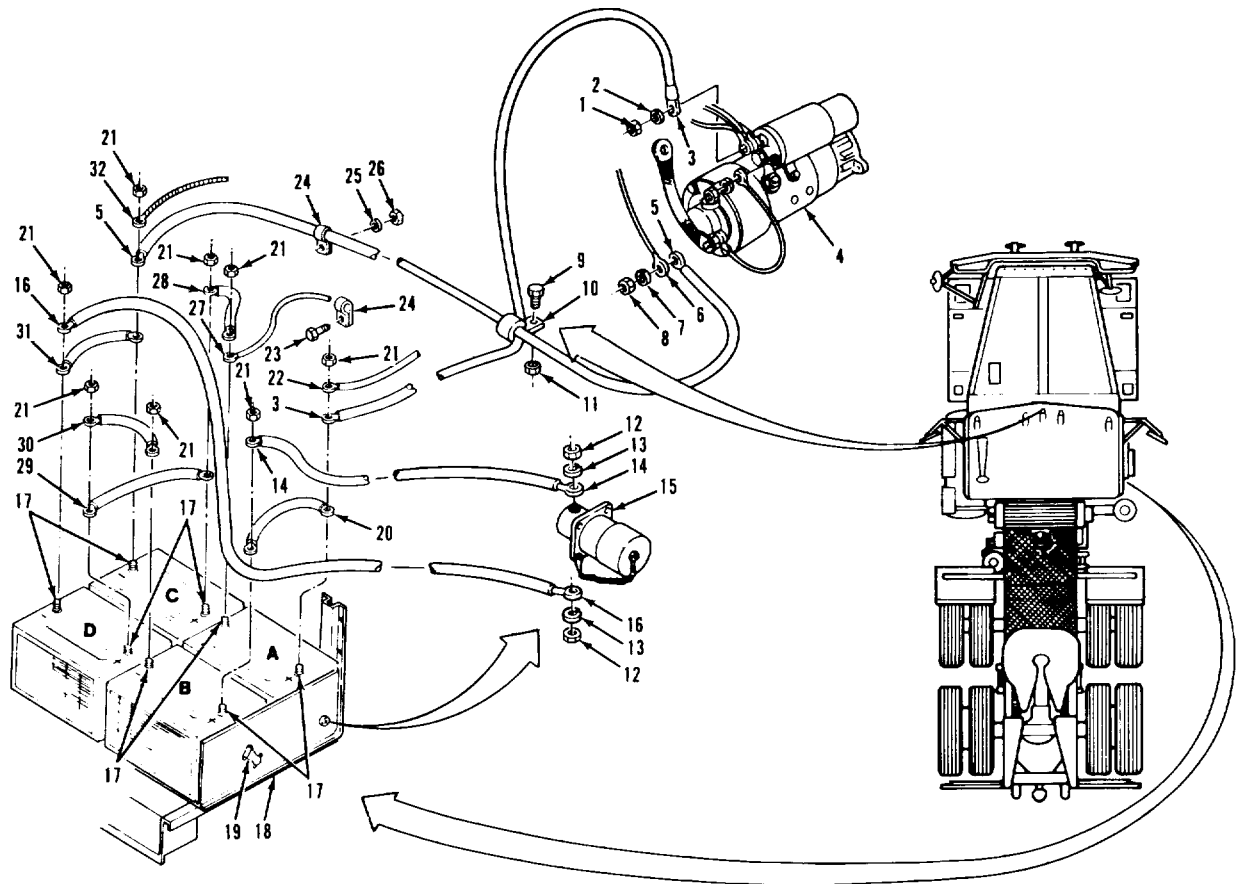

LEGEND:

- |  |   |   |
|--|---|---|
| 1. HEXAGON NUT   | 14. POSITIVE BATTERY POWER CABLE (BATTERY-TO-RECEPTACLE)  | 25. LOCKWASHER  |
| 2. LOCKWASHER  | 15. RECEPTACLE  | 26. NUT   |
| 3. POSITIVE BATTERY POWER CABLE (BATTERY-TO-STARTER MOTOR) | 16. NEGATIVE BATTERY POWER CABLE (BATTERY-TO-RECEPTACLE)  | 27. ENGINE HARNESS 12-VOLT SUPPLY CABLE                   |
| 4. STARTER MOTOR   | 17. TERMINALS (8)   | 28. POSITIVE BATTERY POWER CABLE (BATTERY A-TO-BATTERY C) |
| 5. NEGATIVE BATTERY POWER CABLE (BATTERY-TO-STARTER MOTOR) | 18. BATTERY BOX   | 29. POSITIVE BATTERY POWER CABLE (BATTERY C-TO-BATTERY D) |
| 6. WIRE (98K)  | 19. HOOD HOOK (2)   | 30. POSITIVE BATTERY POWER CABLE (BATTERY B-TO-BATTERY D) |
| 7. LOCKWASHER  | 20. POSITIVE BATTERY POWER CABLE (BATTERY A-TO-BATTERY B) | 31. NEGATIVE BATTERY POWER CABLE (BATTERY D-TO-BATTERY C) |
| 8. HEXAGON NUT   | 21. NUT (8)   | 32. STE/ICE NEGATIVE POWER CABLE                          |
| 9. SCREW   | 22. STE/ICE POSITIVE POWER CABLE                          |   |
| 10. CUSHION CLAMP  | 23. HEXAGON BOLT  |   |
| 11. HEXAGON NUT  | 24. CLAMP (2)   |   |
| 12. SCREW (2)  |   |   |
| 13. WASHER (2)   |   |   |

**ELECTRICAL SYSTEM.**

**3-124. BATTERY CABLE REPLACEMENT (Continued).**

LOCATION/ITEM	ACTION	REMARKS
<b><u>D. NEGATIVE BATTERY POWER CABLE (BATTERY-TO-STARTER MOTOR) REPLACEMENT.</u></b>		
25. Battery ground cables	Disconnect from batteries	Refer to paragraph 3-120.
26. Bolt (23), two clamps (24), lock-washer (25), and nut (26).	Remove from item (5) and frame.	
27. Nut (8), lock-washer (7), wire (6), and cable (5).	Remove from item (4).	
28. Cables (5) and wire (6).	a. Position on item (4). b. Secure with item (8) and item (7). c. Lubricate with grease.	
29. Cable (5)	a. Position in item (24). b. Secure item (24) to frame with item (23), (25), and (26). c. Lubricate with grease.	
30. Battery ground cables	Connect to batteries	Refer to paragraph 3-120.
<b><u>E. POSITIVE BATTERY POWER CABLE (BATTERY-TO-RECEPTACLE) REPLACEMENT.</u></b>		
31. Battery ground cables	Disconnect from batteries	Refer to paragraph 3-120.
32. Nut (21) and cable (14).	Remove from item (17).	
33. Screw (12), washer (13), and cable (14).	Remove from item (15).	
<b>3-724</b>		

**ELECTRICAL SYSTEM.**

**3-124. BATTERY CABLE REPLACEMENT (Continued).**

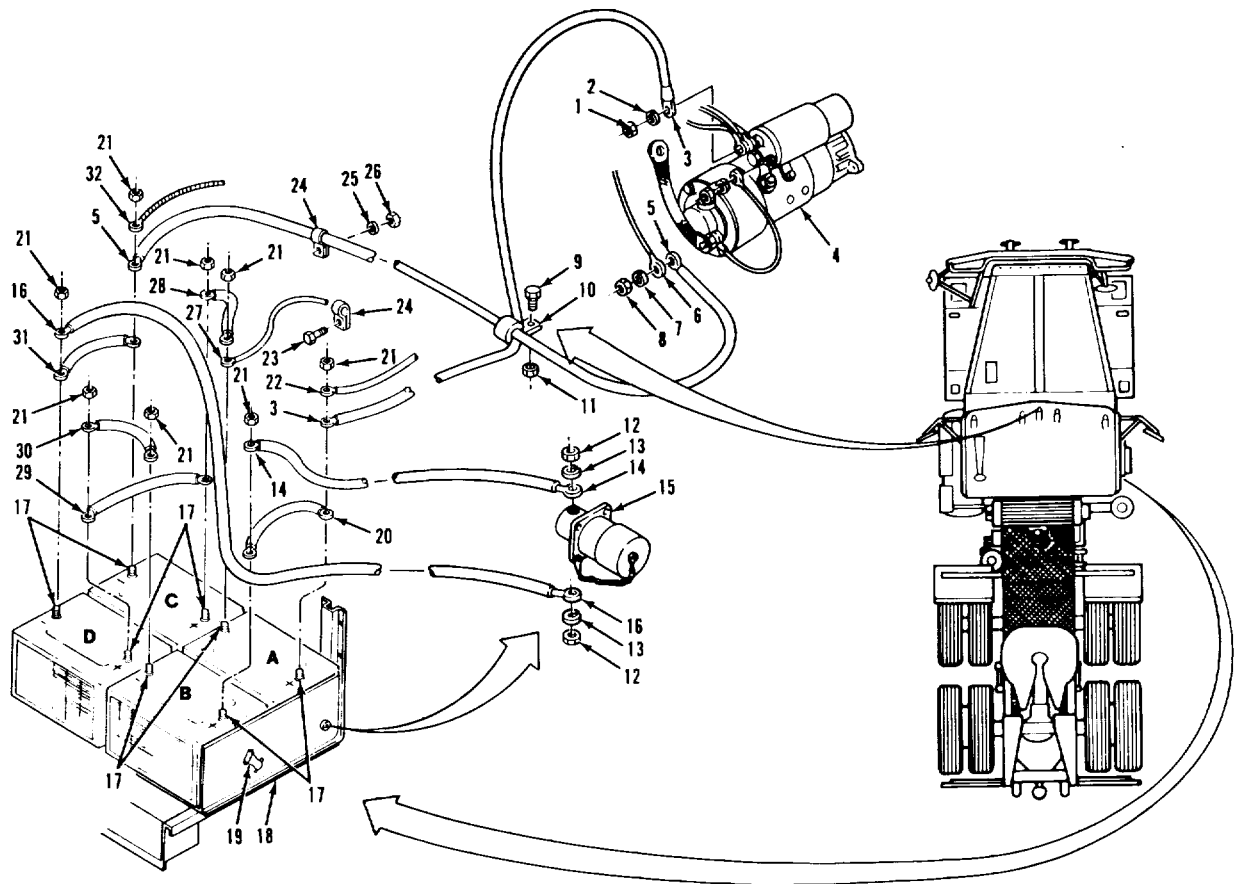

**LEGEND:**

- |  |   |   |
|--|---|---|
| 1. HEXAGON NUT   | 14. POSITIVE BATTERY POWER CABLE (BATTERY-TO-RECEPTACLE)  | 25. LOCKWASHER  |
| 2. LOCKWASHER  | 15. RECEPTACLE  | 26. NUT   |
| 3. POSITIVE BATTERY POWER CABLE (BATTERY-TO-STARTER MOTOR) | 16. NEGATIVE BATTERY POWER CABLE (BATTERY-TO-RECEPTACLE)  | 27. ENGINE HARNESS 12-VOLT SUPPLY CABLE                   |
| 4. STARTER MOTOR   | 17. TERMINALS (8)   | 28. POSITIVE BATTERY POWER CABLE (BATTERY A-TO-BATTERY C) |
| 5. NEGATIVE BATTERY POWER CABLE (BATTERY-TO-STARTER MOTOR) | 18. BATTERY BOX   | 29. POSITIVE BATTERY POWER CABLE (BATTERY C-TO-BATTERY D) |
| 6. WIRE (98K)  | 19. HOOD HOOK (2)   | 30. POSITIVE BATTERY POWER CABLE (BATTERY B-TO-BATTERY D) |
| 7. LOCKWASHER  | 20. POSITIVE BATTERY POWER CABLE (BATTERY A-TO-BATTERY B) | 31. NEGATIVE BATTERY POWER CABLE (BATTERY D-TO-BATTERY C) |
| 8. HEXAGON NUT   | 21. NUT (8)   | 32. STE/ICE NEGATIVE POWER CABLE                          |
| 9. SCREW   | 22. STE/ICE POSITIVE POWER CABLE                          |   |
| 10. CUSHION CLAMP  | 23. HEXAGON BOLT  |   |
| 11. HEXAGON NUT  | 24. CLAMP (2)   |   |
| 12. SCREW (2)  |   |   |
| 13. WASHER (2)   |   |   |

TA 237337

**ELECTRICAL SYSTEM.**

**3-124. BATTERY CABLE REPLACEMENT (Continued).**

LOCATION/ITEM	ACTION	REMARKS
<b><u>E. POSITIVE BATTERY POWER CABLE (BATTERY-TO-RECEPTACLE) REPLACEMENT (Continued).</u></b>		
34. Cable (14)	a. Line up with hole in item (15). b. Secure with item (12) and (13). c. Lubricate with grease.	
35. Cable (14)	a. Position on item (17). b. Secure with item (21). c. Lubricate with grease.	
36. Battery ground cables	Connect to batteries	Refer to paragraph 3-120.
<b><u>F. NEGATIVE BATTERY POWER CABLE (BATTERY-TO-RECEPTACLE) REPLACEMENT.</u></b>		
37. Battery ground cables	Disconnect from batteries	Refer to paragraph 3-120.
38. Screw (12), washer (13), and cable (16)	Remove from item (15)	Access item (12) through hole in bottom of item (18).
39. Cable (16) (15).	a. Line up with hole in item b. Secure with item (12) and (13). c. Lubricate with grease.	
40. Battery ground cables	Connect to batteries	Refer to paragraph 3-120.
<b>3-726</b>		

ELECTRICAL SYSTEM.

3-124. BATTERY CABLE REPLACEMENT (Continued).

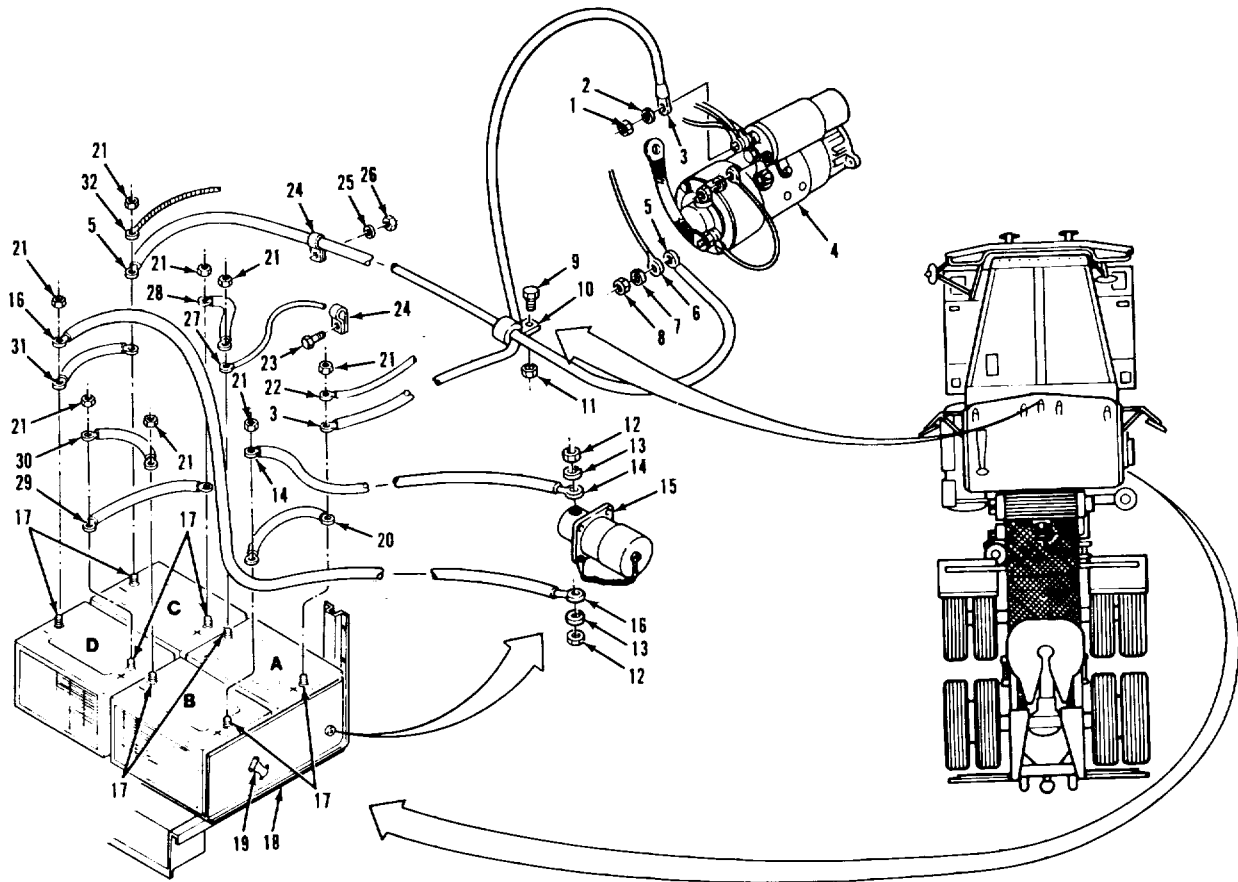

LEGEND:

- |   |   |   |
|---|---|---|
| 1. HEXAGON NUT  | 14. POSITIVE BATTERY<br>POWER CABLE (BATTERY-<br>TO-RECEPTACLE) | 25. LOCKWASHER  |
| 2. LOCKWASHER   | 15. RECEPTACLE  | 26. NUT   |
| 3. POSITIVE BATTERY<br>POWER CABLE (BATTERY-<br>TO-STARTER MOTOR) | 16. NEGATIVE BATTERY<br>POWER CABLE (BATTERY-<br>TO-RECEPTACLE) | 27. ENGINE HARNESS 12-<br>VOLT SUPPLY CABLE                     |
| 4. STARTER MOTOR  | 17. TERMINALS (8)   | 28. POSITIVE BATTERY<br>POWER CABLE (BATTERY<br>A-TO-BATTERY C) |
| 5. NEGATIVE BATTERY<br>POWER CABLE (BATTERY-<br>TO-STARTER MOTOR) | 18. BATTERY BOX   | 29. POSITIVE BATTERY<br>POWER CABLE (BATTERY<br>C-TO-BATTERY D) |
| 6. WIRE (98K)   | 19. HOOD HOOK (2)   | 30. POSITIVE BATTERY<br>POWER CABLE (BATTERY<br>B-TO-BATTERY D) |
| 7. LOCKWASHER   | 20. POSITIVE BATTERY<br>POWER CABLE (BATTERY<br>A-TO-BATTERY B) | 31. NEGATIVE BATTERY<br>POWER CABLE (BATTERY<br>D-TO-BATTERY C) |
| 8. HEXAGON NUT  | 21. NUT (8)   | 32. STE/ICE NEGATIVE<br>POWER CABLE                             |
| 9. SCREW  | 22. STE/ICE POSITIVE<br>POWER CABLE                             |   |
| 10. CUSHION CLAMP   | 23. HEXAGON BOLT  |   |
| 11. HEXAGON NUT   | 24. CLAMP (2)   |   |
| 12. SCREW (2)   |   |   |
| 13. WASHER (2)  |   |   |

TA 237338

**ELECTRICAL SYSTEM.**

**3-124. BATTERY CABLE REPLACEMENT (Continued).**

LOCATION/ITEM	ACTION	REMARKS
<b><u>G. POSITIVE BATTERY POWER CABLE (BATTERY A-TO-BATTERY B) REPLACEMENT.</u></b>		
41. Battery ground cables	Disconnect from batteries	Refer to paragraph 3-120.
42. Nut (23) and cables (22), (23), and (20).	Remove from item (17).	
43. Nut (21) and cables (14) and (20)	a. Remove from item (17). b. Remove item (20).	
44. Cables (20) and (14).	a. Position on item (17). b. Secure with item (21). c. Lubricate with grease.	
45. Cables (20), (3), and (22).	a. Position on item (17). b. Secure with item (21). c. Lubricate with grease.	
46. Battery ground cables	Connect to batteries	Refer to paragraph 3-120.
<b><u>H. POSITIVE BATTERY POWER CABLE (BATTERY A-TO-BATTERY C) REPLACEMENT. I</u></b>		
47. Battery ground cables	Disconnect for batteries	Refer to paragraph 3-120.
48. Nut (21) and cable (28).	Remove from item (17).	
49. Cable (28)	a. Position on item (17). b. Secure with nut (21).	
50. Battery ground cables	Connect to batteries	Refer to paragraph 3-120.



**ELECTRICAL SYSTEM.**

**3-124. BATTERY CABLE REPLACEMENT (Continued).**

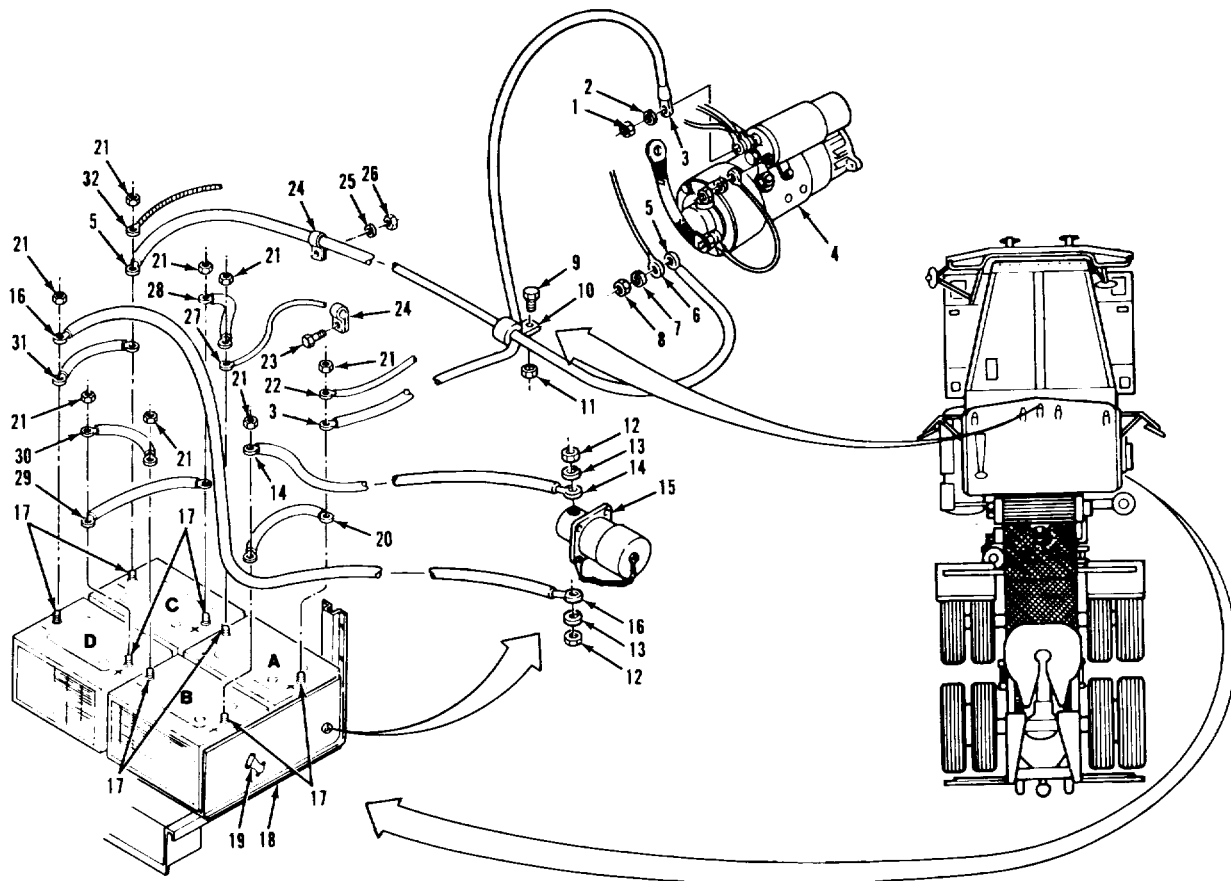

**LEGEND:**

- |  |   |   |
|--|---|---|
| 1. HEXAGON NUT   | 14. POSITIVE BATTERY POWER CABLE (BATTERY-TO-RECEPTACLE)  | 25. LOCKWASHER  |
| 2. LOCKWASHER  | 15. RECEPTACLE  | 26. NUT   |
| 3. POSITIVE BATTERY POWER CABLE (BATTERY-TO-STARTER MOTOR) | 16. NEGATIVE BATTERY POWER CABLE (BATTERY-TO-RECEPTACLE)  | 27. ENGINE HARNESS 12-VOLT SUPPLY CABLE                   |
| 4. STARTER MOTOR   | 17. TERMINALS (8)   | 28. POSITIVE BATTERY POWER CABLE (BATTERY A-TO-BATTERY C) |
| 5. NEGATIVE BATTERY POWER CABLE (BATTERY-TO-STARTER MOTOR) | 18. BATTERY BOX   | 29. POSITIVE BATTERY POWER CABLE (BATTERY C-TO-BATTERY D) |
| 6. WIRE (98K)  | 19. HOOD HOOK (2)   | 30. POSITIVE BATTERY POWER CABLE (BATTERY B-TO-BATTERY D) |
| 7. LOCKWASHER  | 20. POSITIVE BATTERY POWER CABLE (BATTERY A-TO-BATTERY B) | 31. NEGATIVE BATTERY POWER CABLE (BATTERY D-TO-BATTERY C) |
| 8. HEXAGON NUT   | 21. NUT (8)   | 32. STE/ICE NEGATIVE POWER CABLE                          |
| 9. SCREW   | 22. STE/ICE POSITIVE POWER CABLE                          |   |
| 10. CUSHION CLAMP  | 23. HEXAGON BOLT  |   |
| 11. HEXAGON NUT  | 24. CLAMP (2)   |   |
| 12. SCREW (2)  |   |   |
| 13. WASHER (2)   |   |   |

TA 237339

**ELECTRICAL SYSTEM.**

**3-124. BATTERY CABLE REPLACEMENT (Continued).**

LOCATION/ITEM	ACTION	REMARKS
<b><u>I. POSITIVE BATTERY POWER CABLE (BATTERY C-TO-BATTERY D) REPLACEMENT.</u></b>		
51 Battery ground cables	Disconnect from batteries	Refer to paragraph 3-120.
52 Nut (21) and cables (28) and (29).	Remove from item (17).	
53 Nut (21) and cables (30) and (29)	a. Remove from item (17). b. Remove item (29).	
54 Cables (29) and (30).	a. Position on item (17). b. Secure with item (21). c. Lubricate with grease.	
55. Cables (29) and (28).	a. Position on item (17). b. Secure with item (21). c. Lubricate with grease.	
56 Battery ground cables	Connect to batteries	Refer to paragraph 3-120.
<b><u>J. POSITIVE BATTERY POWER CABLE (BATTERY B-TO-BATTERY D) REPLACEMENT.</u></b>		
57 Battery ground cables	Disconnect from batteries	Refer to paragraph 3-120.
58 Nut (21) and cable (30).	Remove from item (17).	

**ELECTRICAL SYSTEM.**

**3-124. BATTERY CABLE REPLACEMENT (Continued).**

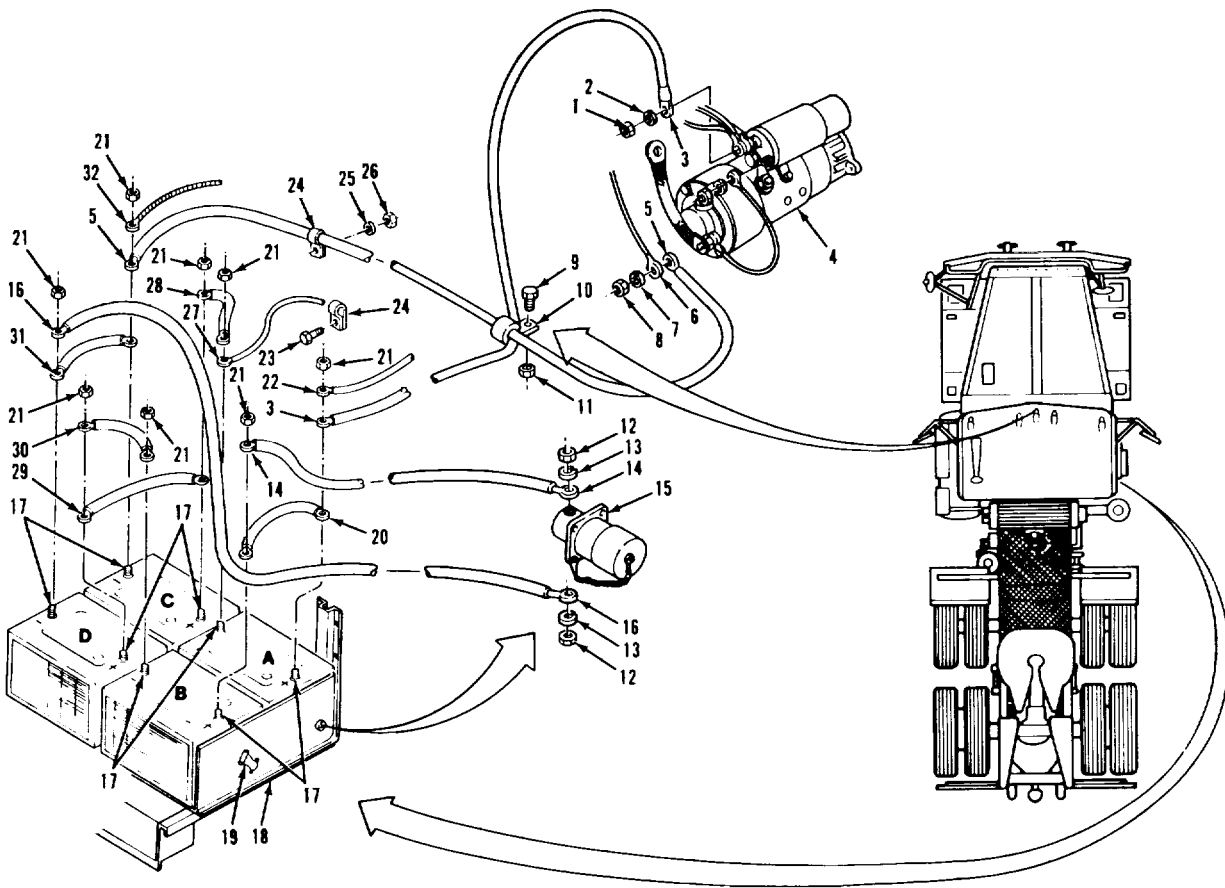

**LEGEND:**

- |  |   |   |
|--|---|---|
| 1. HEXAGON NUT   | 14. POSITIVE BATTERY POWER CABLE (BATTERY-TO-RECEPTACLE)  | 25. LOCKWASHER  |
| 2. LOCKWASHER  | 15. RECEPTACLE  | 26. NUT   |
| 3. POSITIVE BATTERY POWER CABLE (BATTERY-TO-STARTER MOTOR) | 16. NEGATIVE BATTERY POWER CABLE (BATTERY-TO-RECEPTACLE)  | 27. ENGINE HARNESS 12-VOLT SUPPLY CABLE                   |
| 4. STARTER MOTOR   | 17. TERMINALS (8)   | 28. POSITIVE BATTERY POWER CABLE (BATTERY A-TO-BATTERY C) |
| 5. NEGATIVE BATTERY POWER CABLE (BATTERY-TO-STARTER MOTOR) | 18. BATTERY BOX   | 29. POSITIVE BATTERY POWER CABLE (BATTERY C-TO-BATTERY D) |
| 6. WIRE (98K)  | 19. HOOD HOOK (2)   | 30. POSITIVE BATTERY POWER CABLE (BATTERY B-TO-BATTERY D) |
| 7. LOCKWASHER  | 20. POSITIVE BATTERY POWER CABLE (BATTERY A-TO-BATTERY B) | 31. NEGATIVE BATTERY POWER CABLE (BATTERY D-TO-BATTERY C) |
| 8. HEXAGON NUT   | 21. NUT (8)   | 32. STE/ICE NEGATIVE POWER CABLE                          |
| 9. SCREW   | 22. STE/ICE POSITIVE POWER CABLE                          |   |
| 10. CUSHION CLAMP  | 23. HEXAGON BOLT  |   |
| 11. HEXAGON NUT  | 24. CLAMP (2)   |   |
| 12. SCREW (2)  |   |   |
| 13. WASHER (2)   |   |   |

TA 237340

**ELECTRICAL SYSTEM.**

**3-124. BATTERY CABLE REPLACEMENT (Continued).**

LOCATION/ITEM	ACTION	REMARKS
<b><u>J. POSITIVE BATTERY POWER CABLE (BATTERY B-TO-BATTERY D) REPLACEMENT(Continued).</u></b>		
59. Nut (21) and cable (30).	a. Remove from item (17).	
	b. Remove item (30).	
60. Cable (30)	a. Position on item (17).	
	b. Secure with item (21).	
	c. Lubricate with grease.	
61. Cable (30)	a. Position on item (17).	
	b. Secure with item (21).	
	c. Lubricate with grease.	
62. Battery ground cables	Connect to batteries	Refer to paragraph 3-120.
<b><u>K. NEGATIVE BATTERY POWER CABLE (BATTERY D-TO-BATTERY C) REPLACEMENT.</u></b>		
63. Nut (21) and cables (32), (5), and (31).	Remove from item (17).	
64. Nut (21) and cables (16) and (31)	a. Remove from item (17).	
	b. Remove cable (31).	
65. Cables (31) and (16).	a. Position on item (17).	
	b. Secure with item (21).	
	c. Lubricate with grease.	
<b>3-732</b>		

ELECTRICAL SYSTEM.

3-124. BATTERY CABLE REPLACEMENT (Continued).

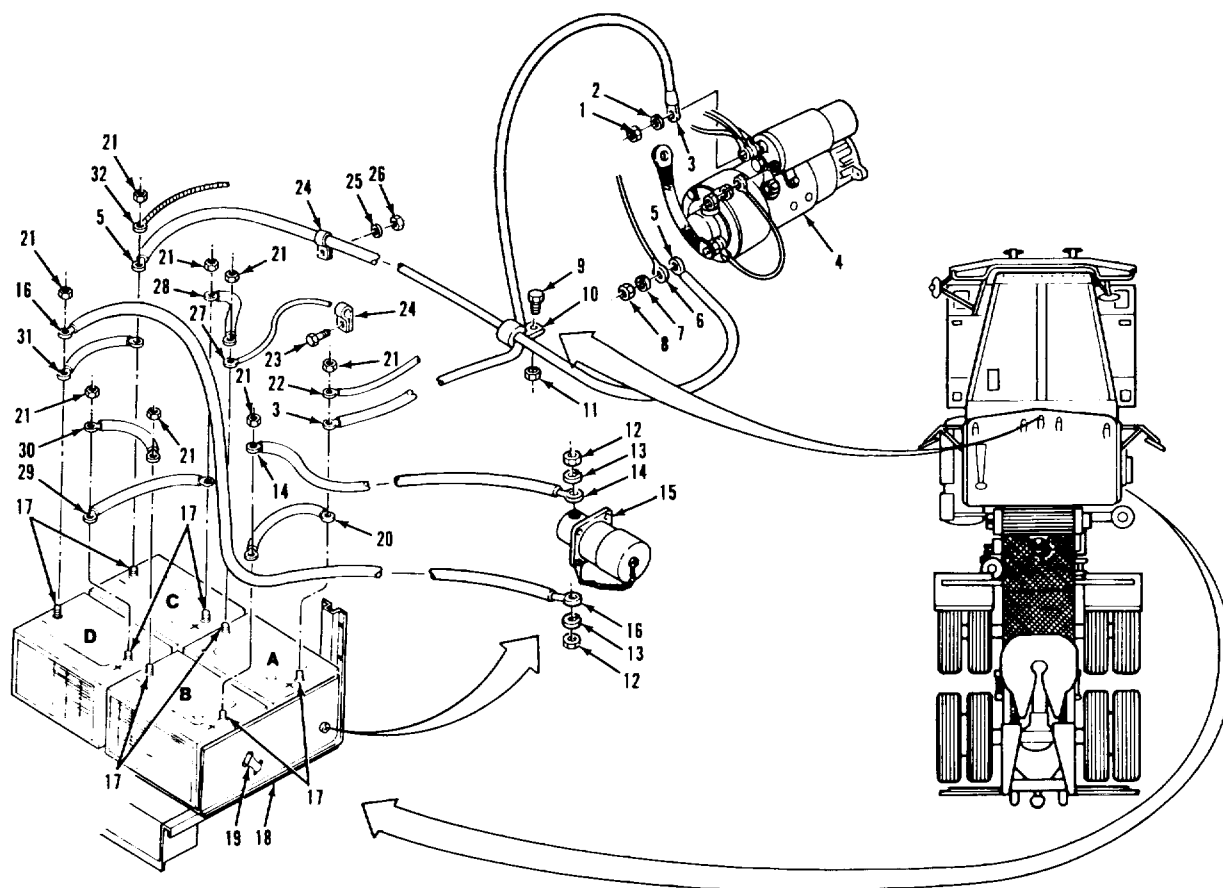

LEGEND:

- |  |   |   |
|--|---|---|
| 1. HEXAGON NUT   | 14. POSITIVE BATTERY POWER CABLE (BATTERY-TO-RECEPTACLE)  | 25. LOCKWASHER  |
| 2. LOCKWASHER  | 15. RECEPTACLE  | 26. NUT   |
| 3. POSITIVE BATTERY POWER CABLE (BATTERY-TO-STARTER MOTOR) | 16. NEGATIVE BATTERY POWER CABLE (BATTERY-TO-RECEPTACLE)  | 27. ENGINE HARNESS 12-VOLT SUPPLY CABLE                   |
| 4. STARTER MOTOR   | 17. TERMINALS (8)   | 28. POSITIVE BATTERY POWER CABLE (BATTERY A-TO-BATTERY C) |
| 5. NEGATIVE BATTERY POWER CABLE (BATTERY-TO-STARTER MOTOR) | 18. BATTERY BOX   | 29. POSITIVE BATTERY POWER CABLE (BATTERY C-TO-BATTERY D) |
| 6. WIRE (98K)  | 19. HOOD HOOK (2)   | 30. POSITIVE BATTERY POWER CABLE (BATTERY B-TO-BATTERY D) |
| 7. LOCKWASHER  | 20. POSITIVE BATTERY POWER CABLE (BATTERY A-TO-BATTERY B) | 31. NEGATIVE BATTERY POWER CABLE (BATTERY D-TO-BATTERY C) |
| 8. HEXAGON NUT   | 21. NUT (8)   | 32. STE/ICE NEGATIVE POWER CABLE                          |
| 9. SCREW   | 22. STE/ICE POSITIVE POWER CABLE                          |   |
| 10. CUSHION CLAMP  | 23. HEXAGON BOLT  |   |
| 11. HEXAGON NUT  | 24. CLAMP (2)   |   |
| 12. SCREW (2)  |   |   |
| 13. WASHER (2)   |   |   |

TA 237341

**ELECTRICAL SYSTEM.**

**3-124. BATTERY CABLE REPLACEMENT (Continued).**

LOCATION/ITEM	ACTION	REMARKS
<p><b><u>K. NEGATIVE BATTERY POWER CABLE (BATTERY D-TO-BATTERY C) REPLACEMENT (Continued).</u></b></p>		
<p>66. Cables (31), (5), and (32).</p>	<p>a. Position on item (17).                      b. Secure with item (21).                      c. Lubricate with grease.</p>	
<p><b><u>L. CLEANING AND INSPECTING CABLES.</u></b></p>		
<p>67. All cables and terminals.</p>	<p>a. Clean with wire brush and sodium bicarbonate.                      b. Rinse with clear water and dry thoroughly with clean dry rags.</p>	
<p>68. All cables.</p>	<p>a. Inspect for cracked and cut insulation.                      b. Inspect for cracked or broken lugs.</p>	
<p style="text-align: center;"><b>NOTE</b>                      Follow-on maintenance action required: Install battery box cover (TM 9-2320- 283-10).</p>		
<p style="text-align: center;"><b>3-734</b></p>		

ELECTRICAL SYSTEM.

3-124. BATTERY CABLE REPLACEMENT (Continued).

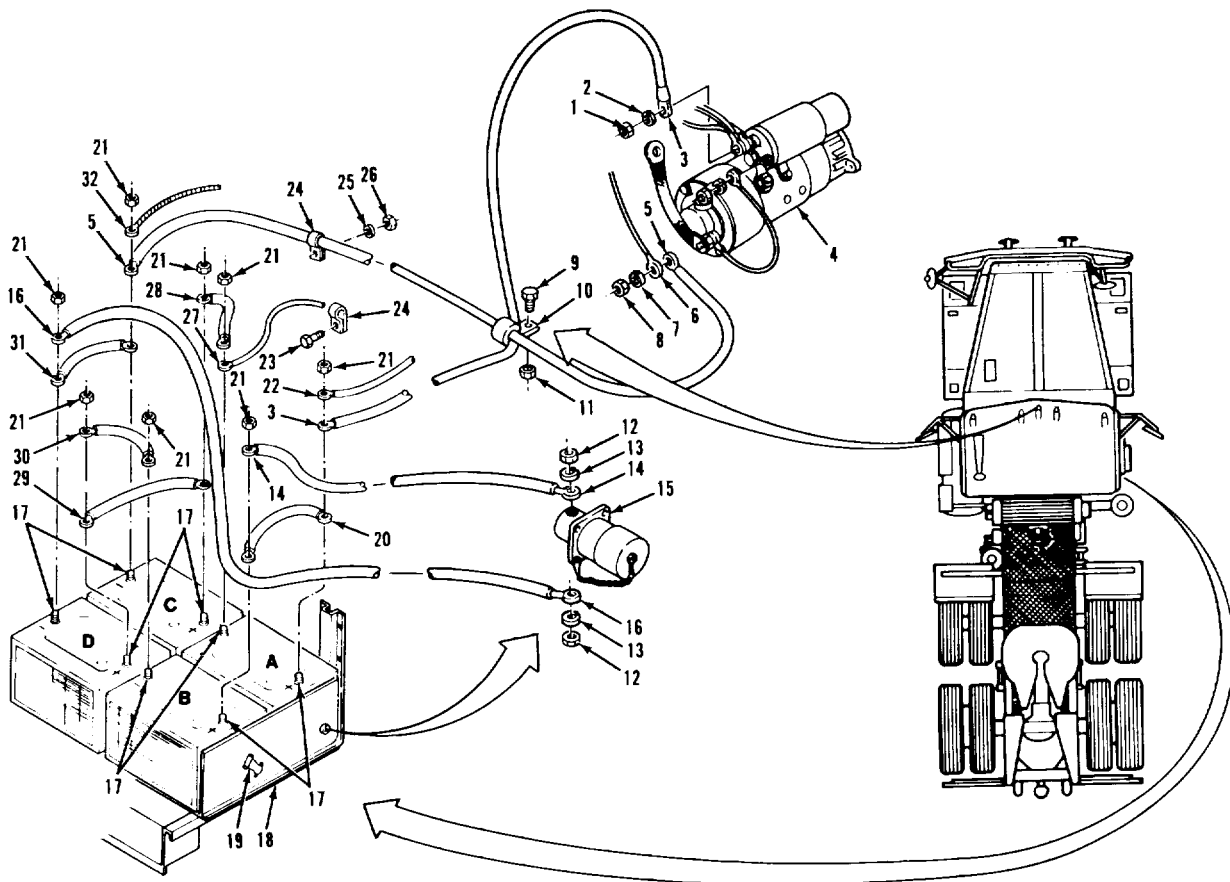

LEGEND:

- |  |   |   |
|--|---|---|
| 1. HEXAGON NUT   | 14. POSITIVE BATTERY POWER CABLE (BATTERY-TO-RECEPTACLE)  | 25. LOCKWASHER  |
| 2. LOCKWASHER  | 15. RECEPTACLE  | 26. NUT   |
| 3. POSITIVE BATTERY POWER CABLE (BATTERY-TO-STARTER MOTOR) | 16. NEGATIVE BATTERY POWER CABLE (BATTERY-TO-RECEPTACLE)  | 27. ENGINE HARNESS 12-VOLT SUPPLY CABLE                   |
| 4. STARTER MOTOR   | 17. TERMINALS (8)   | 28. POSITIVE BATTERY POWER CABLE (BATTERY A-TO-BATTERY C) |
| 5. NEGATIVE BATTERY POWER CABLE (BATTERY-TO-STARTER MOTOR) | 18. BATTERY BOX   | 29. POSITIVE BATTERY POWER CABLE (BATTERY C-TO-BATTERY D) |
| 6. WIRE (98K)  | 19. HOOD HOOK (2)   | 30. POSITIVE BATTERY POWER CABLE (BATTERY B-TO-BATTERY D) |
| 7. LOCKWASHER  | 20. POSITIVE BATTERY POWER CABLE (BATTERY A-TO-BATTERY B) | 31. NEGATIVE BATTERY POWER CABLE (BATTERY D-TO-BATTERY C) |
| 8. HEXAGON NUT   | 21. NUT (8)   | 32. STE/ICE NEGATIVE POWER CABLE                          |
| 9. SCREW   | 22. STE/ICE POSITIVE POWER CABLE                          |   |
| 10. CUSHION CLAMP  | 23. HEXAGON BOLT  |   |
| 11. HEXAGON NUT  | 24. CLAMP (2)   |   |
| 12. SCREW (2)  |   |   |
| 13. WASHER (2)   |   |   |

TA 237342

**ELECTRICAL SYSTEM.**

**3-125. SLAVE START RECEPTACLE REPLACEMENT.**

---

THIS TASK COVERS

- a. Removal.
  - b. Installation.
- 

INITIAL SETUP

APPLICABLE CONFIGURATIONS

All.

TEST EQUIPMENT

None.

SPECIAL TOOLS

None.

MATERIALS/PARTS (P/N)

None.

PERSONNEL REQUIRED

One (MOS-63S).

REFERENCES (TM)

None.

TROUBLESHOOTING REFERENCES

Paragraph 2-11.

EQUIPMENT CONDITION

PARAGRAPH

3-120.

CONDITION DESCRIPTION

Disconnect battery power.

SPECIAL ENVIRONMENTAL CONDITIONS

None.

GENERAL SAFETY INSTRUCTIONS

Engine off.  
Transmission in neutral.  
Park brake set.



ELECTRICAL SYSTEM.

3-125. SLAVE START RECEPTACLE REPLACEMENT (Continued).

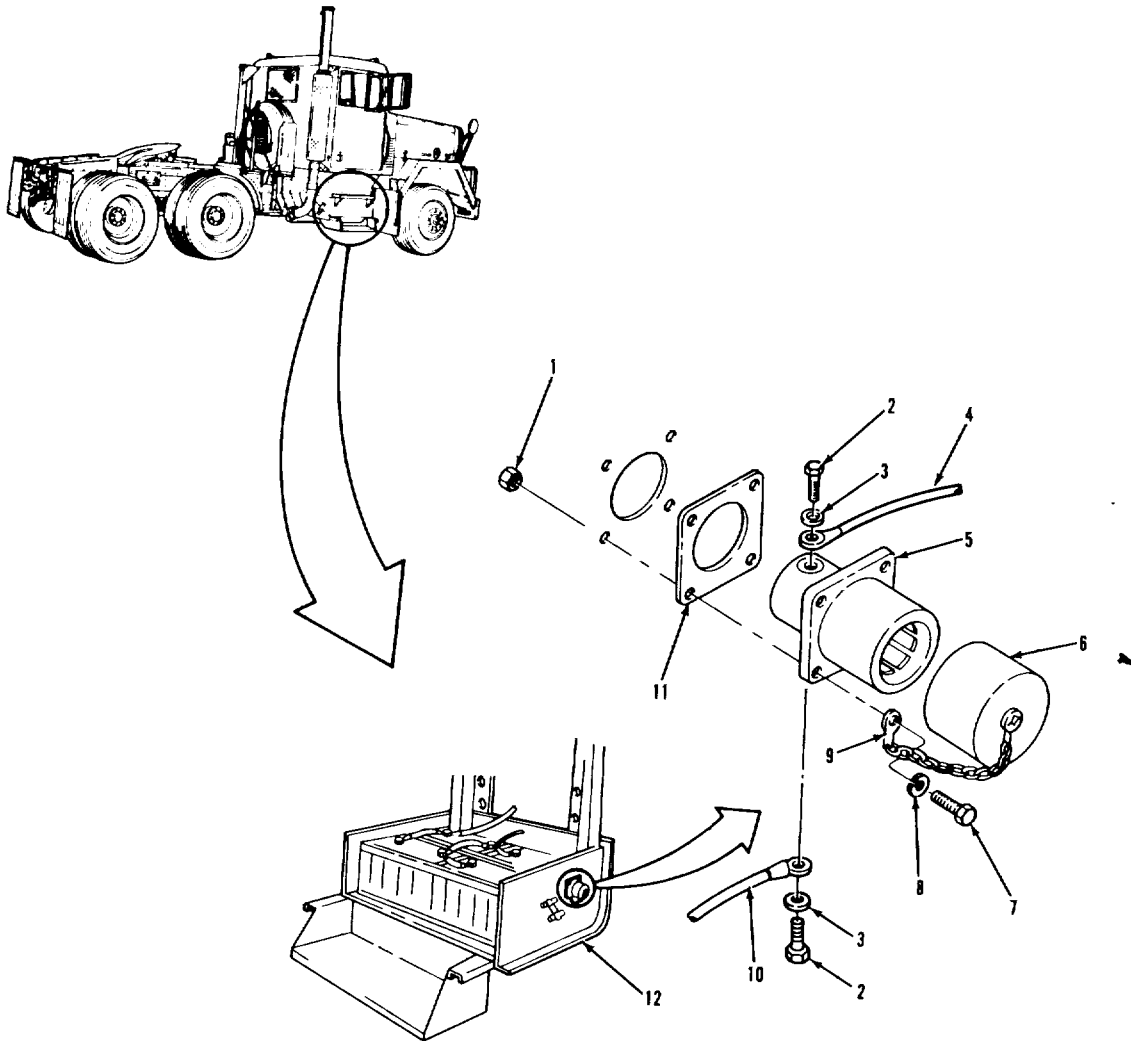

LEGEND:

- 1. NUT (4)
- 2. SCREW (2)
- 3. WASHER (2)
- 4. CABLE ASSEMBLY
- 5. RECEPTACLE
- 6. COVER

- 7. SCREW (4)
- 8. LOCKWASHER (4)
- 9. COVER CHAIN
- 10. CABLE ASSEMBLY
- 11. INSULATOR
- 12. BATTERY BOX ASSEMBLY

TA 237343

**ELECTRICAL SYSTEM.**

**3-125. SLAVE START RECEPTACLE REPLACEMENT (Continued).**

LOCATION/ITEM	ACTION	REMARKS
<b><u>A. REMOVAL.</u></b>		
1. Two screws (2), washers (3), cable assembly (4), and cable assembly (10).	Remove from item (5).	Tag item (4) and item (10) for identification.
2. Four screws (7), lockwashers (8), and nuts (1).	Remove from item (5).	
3. Receptacle (5) and insulator (11).	Remove from item (12).	
4. Cover (6).	Remove from item (5).	
<b><u>B. INSTALLATION.</u></b>		
5. Cover (6).	Install on item (5).	
6. Receptacle (5) and insulator (11).	Put in place in item (12).	
7. Four screws (7), lockwashers (8), and nuts (1).	Secure item (9), item (5), and item (11) to item (12).	
8. Two screws (2) and washers (3).	Secure item (4) and item (10) to item (5).	
<b>NOTE</b>		
Follow-on maintenance action required:		
Connect batteries (para 3-120).		
<b>3-738</b>		

ELECTRICAL SYSTEM.

3-125. SLAVE START RECEPTACLE REPLACEMENT (Continued).

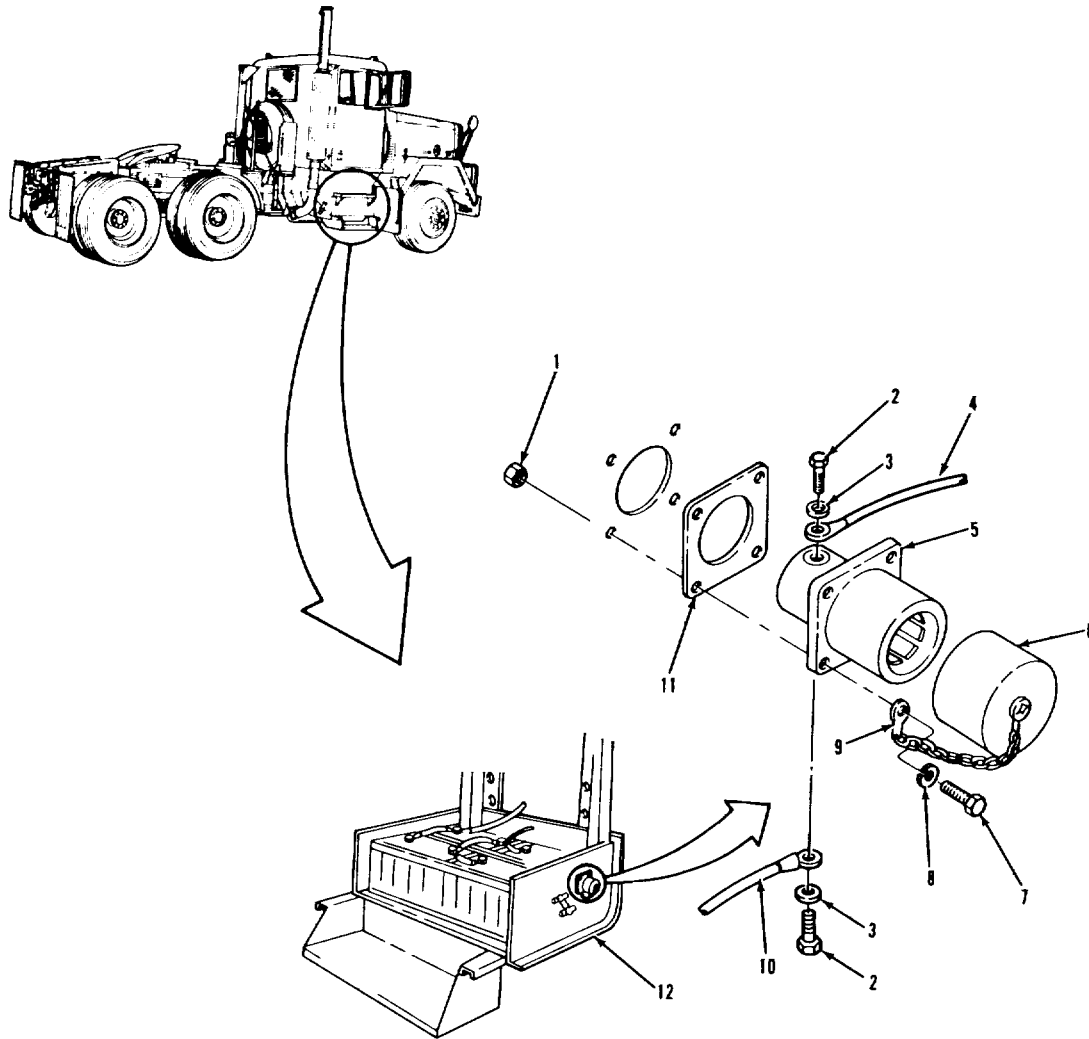

LEGEND:

- 1. NUT (4)
- 2. SCREW (2)
- 3. WASHER (2)
- 4. CABLE ASSEMBLY
- 5. RECEPTACLE
- 6. COVER

- 7. SCREW (4)
- 8. LOCKWASHER (4)
- 9. COVER CHAIN
- 10. CABLE ASSEMBLY
- 11. INSULATOR
- 12. BATTERY BOX ASSEMBLY

TA 237344

**ELECTRICAL SYSTEM.**  
**3-126. WIRING HARNESS REPLACEMENT.**

---

THIS TASK COVERS  
 Replacement.

---

INITIAL SETUP

EQUIPMENT CONDITION  
APPLICABLE CONFIGURATIONS  
 All.

PARAGRAPH  
 3-120.

CONDITION DESCRIPTION  
 Battery power  
 disconnected.

TEST EQUIPMENT

None.

SPECIAL TOOLS

None.

MATERIALS/PARTS (P/N)

Tie, cable (as required)  
 (06383) SST4S.

PERSONNEL REQUIRED

One (MOS-63S .

REFERENCES (TM)

TM 9-2320-283-20P.

SPECIAL ENVIRONMENTAL CONDITIONS

None.

GENERAL SAFETY INSTRUCTIONS

Engine off.  
 Transmission in neutral.  
 Park brake set.

TROUBLESHOOTING REFERENCES

Paragraph 2-11.

**ELECTRICAL SYSTEM.**

**3-126. WIRING HARNESS REPLACEMENT (Continued).**

LOCATION/ITEM	ACTION	REMARKS
<p><b><u>REPLACEMENT</u></b></p> <p style="text-align: center;"><b>NOTE</b></p> <ul style="list-style-type: none"> <li>• For replacement of vehicle wiring harness, refer to Appendix D for harness routing and location. Use standard shop maintenance procedures for removing harness clamps and cables ties. Be sure to tag terminal ends to insure proper installation. For repair of wiring harness connector ends, refer to paragraph 3-127.</li> <li>• Follow-on maintenance action required: Connect batteries (para 3-120).</li> </ul> <p style="text-align: center;"><b>3-741</b></p>		

**ELECTRICAL SYSTEM.****3-127. WIRING HARNESS REPAIR.**

---

**THIS TASK COVERS**

- a. STE/ICE Connector Receptacle Repair.
  - b. Circular Connector Plug Repair.
  - c. Circular Connector Receptacle Repair.
  - d. Relay Connector Receptacle Repair.
  - e. 24-Volt Connector Receptacle Repair.
  - f. 12-Volt Connector Receptacle Repair.
  - g. Plastic Connector Receptacle or Plug Repair.
  - h. Wire Replacement.
- 

**INITIAL SETUP****EQUIPMENT CONDITION****APPLICABLE CONFIGURATIONS**

All.

**PARAGRAPH**

3-120.

**CONDITION DESCRIPTION**Battery power  
disconnected.**TEST EQUIPMENT**

None.

**SPECIAL TOOLS**

As required.

**MATERIALS/PARTS (P/N)**

As required.

**PERSONNEL REQUIRED**

One (MOS-63G .

**REFERENCES (TM)**

TM 9-2320-283-20P.

**SPECIAL ENVIRONMENTAL CONDITIONS**

None.

**GENERAL SAFETY INSTRUCTIONS**

Engine off.

Transmission in neutral.

Park brake set.

**TROUBLESHOOTING REFERENCES**

Paragraph 2-11.

ELECTRICAL SYSTEM.

3-127. WIRING HARNESS REPAIR (Continued).

NOTE

Repair of harness is limited to repair of connector ends and replacement of wires. A location view and legend of all connector ends is shown below. The subparagraph letter for repair of each type of connector end is shown after the connector end name in the legend.

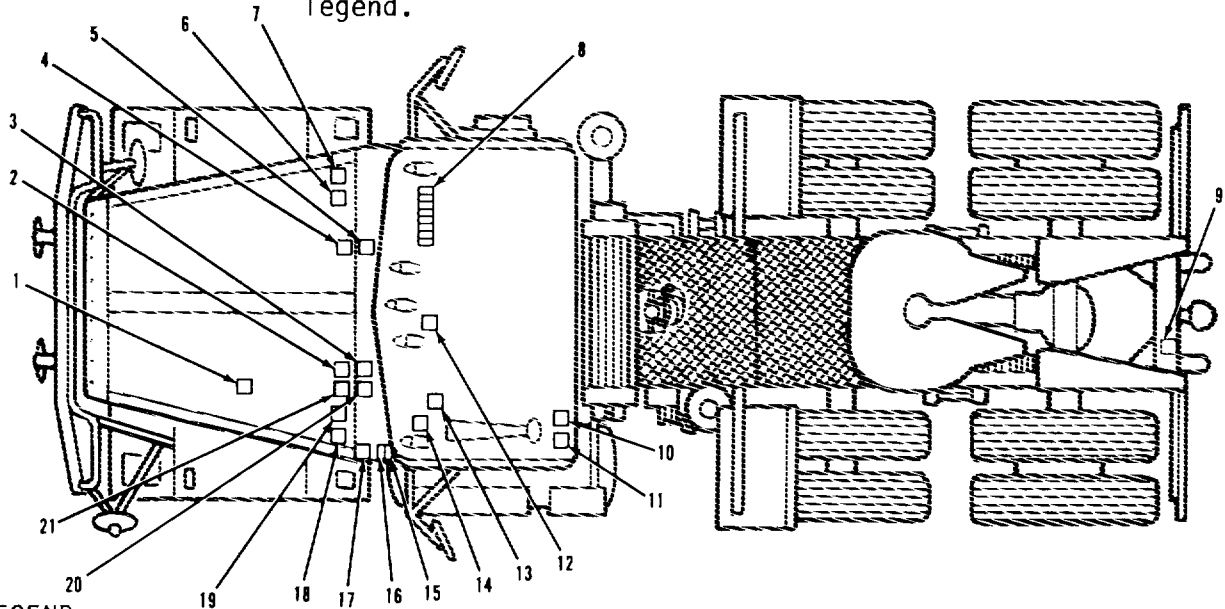

LEGEND:

- |   |   |
|---|---|
| 1. STE/ICE CONNECTOR RECEPTACLE (A)                         | 13. TURN SIGNAL SWITCH CONNECTOR RECEPTACLE (G)       |
| 2. ENGINE HARNESS CONNECTOR PLUG (B)                        | 14. IGNITION SWITCH CONNECTOR RECEPTACLE (G)          |
| 3. ENGINE HARNESS CONNECTOR RECEPTACLE (C)                  | 15. CAB MARKER LAMPS CONNECTOR PLUG (6)               |
| 4. FRONT CAB AND UNDERBODY HARNESS CONNECTOR PLUG (B)       | 16. CAB MARKER LAMPS CONNECTOR RECEPTACLE (G)         |
| 5. FRONT CAB AND UNDERBODY HARNESS CONNECTOR RECEPTACLE (C) | 17. DIMMER SWITCH CONNECTOR RECEPTACLE (G)            |
| 6. RIGHT HAND FENDER HARNESS CONNECTOR RECEPTACLE (C)       | 18. LEFT HAND FENDER HARNESS CONNECTOR PLUG (B)       |
| 7. RIGHT HAND FENDER HARNESS CONNECTOR PLUG (B)             | 19. LEFT HAND FENDER HARNESS CONNECTOR RECEPTACLE (C) |
| 8. RELAY CONNECTOR RECEPTACLE (D)                           | 20. CHASSIS HARNESS CONNECTOR RECEPTACLE (C)          |
| 9. 24-VOLT CONNECTOR RECEPTACLE (D)                         | 21. CHASSIS HARNESS CONNECTOR PLUG (B)                |
| 10. 24-VOLT CONNECTOR RECEPTACLE (E)                        |   |
| 11. 12-VOLT CONNECTOR RECEPTACLE (F)                        |   |
| 12. HEADLAMP SWITCH CONNECTOR RECEPTACLE (G)                |   |

TA 237345

**ELECTRICAL SYSTEM.**  
**3-127. WIRING HARNESS REPAIR (Continued).**

LOCATION/ITEM	ACTION	REMARKS
<b><u>A. STE/ICE CONNECTOR RECEPTACLE REPAIR.</u></b>		
1. Cap (29).	Unscrew and remove from item (1).	
2. Four screws (31).	Remove from items (1), (28), and (30).	
3. Receptacle (1).	Remove from item (28).	
4. Two screws (24).	Loosen, but do not remove.	
5. Clamp (23).	Unscrew from item (22) and pull back onto item (25).	
6. Endbell (22).	Unscrew from item (1) and pull back onto item (25).	
7. Socket (27).	Using item (32), push out towards rear end of item (1).	If item (1) is being replaced, repeat this step until all items (27) have been removed. Be sure to tag items (26).
8. All parts.	Clean and inspect.	Refer to paragraphs 3-4 and 3-5. If any items (27) are damaged, do steps 9 and 10.
9. Socket (27).	Remove from item (26) and discard.	
<b>3-744</b>		



ELECTRICAL SYSTEM.

3-127. WIRING HARNESS REPAIR (Continued).

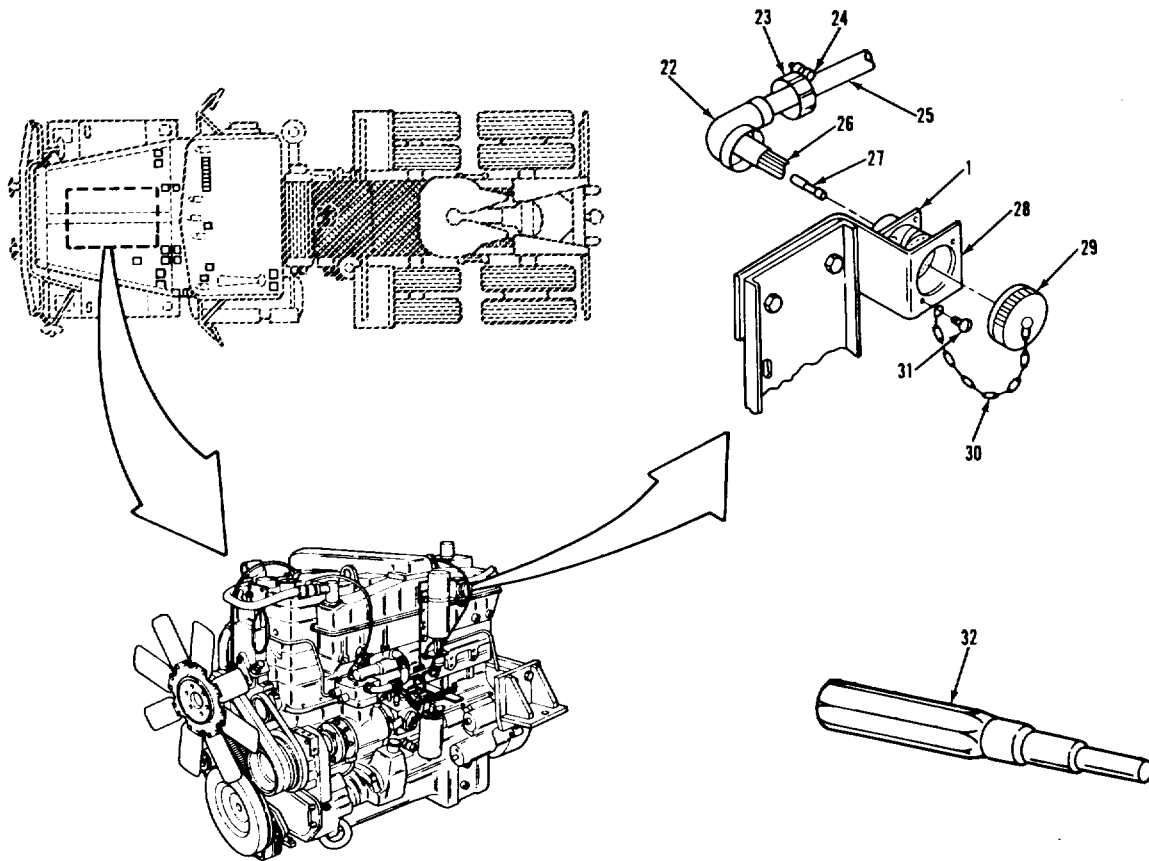

LEGEND:

- 1. STE/ICE CONNECTOR RECEPTACLE
- 22. 90° ENDBELL ASSEMBLY
- 23. CABLE CLAMP
- 24. SCREW (2)
- 25. ENGINE HARNESS ASSEMBLY
- 26. WIRE (39)

- 27. STE/ICE CONNECTOR SOCKET (39)
- 28. STE/ICE CONNECTOR BRACKET
- 29. STE/ICE CONNECTOR CAP
- 30. CAP CHAIN
- 31. CAPSCREW (4)
- 32. CONTACT EXTRACTION TOOL

TA 237346

**ELECTRICAL SYSTEM.**

**3-127. WIRING HARNESS REPAIR (Continued).**

LOCATION/ITEM	ACTION	REMARKS
<b><u>A STE/ICE CONNECTOR RECEPTACLE REPAIR (Continued)</u></b>		
10 New socket (27)	Using items (34) and (35), install onto item (26)	Be careful not to damage item (27) during this step.
11 Socket (27)	Using item (33), install into item (1)	If item (1) is new, repeat this step until all items (27) have been installed. Check the mating side of item (1) to make sure all items (27) are on the same level.
12 Endbell (22)	Screw onto item (1), but do not tighten.	
13 Clamp (23)	Screw onto item (22), and hand tighten.	
14 Two screws (24)	Tighten until snug.	
15 Receptacle (1) and chain (30).	a Position on item (28).  b Secure with four items (31).	
16 Endbell (22)	Tighten onto item (1).	
17 Cap (29)	Secure onto item (1) until it clicks into place.	

**ELECTRICAL SYSTEM.**  
**3-127. WIRING HARNESS REPAIR (Continued).**

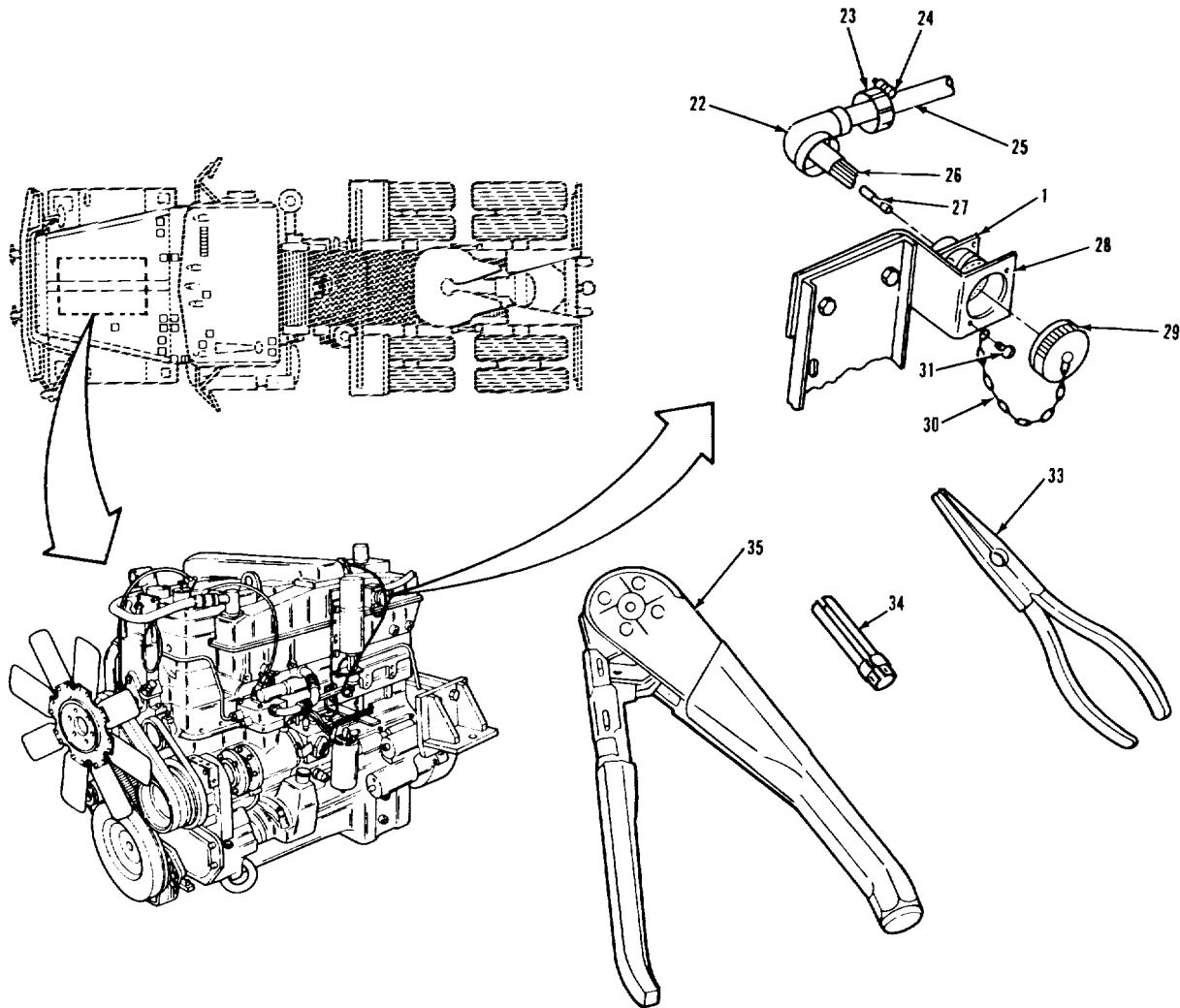

**LEGEND:**

- |                                   |                               |
|-----------------------------------|-------------------------------|
| 1. STE/ICE CONNECTOR RECEPTACLE   | 28. STE/ICE CONNECTOR BRACKET |
| 22. 90° ENDBELL ASSEMBLY          | 29. STE/ICE CONNECTOR CAP     |
| 23. CABLE CLAMP                   | 30. CAP CHAIN                 |
| 24. SCREW (2)                     | 31. CAPSCREW (4)              |
| 25. ENGINE HARNESS ASSEMBLY       | 33. CONTACT INSERTION TOOL    |
| 26. WIRE (39)                     | 34. SOCKET CONTACT LOCATOR    |
| 27. STE/ICE CONNECTOR SOCKET (39) | 35. CRIMPING TOOL             |

TA 237347

**ELECTRICAL SYSTEM.**  
**3-127. WIRING HARNESS REPAIR (Continued).**

LOCATION/ITEM	ACTION	REMARKS
<b><u>B. CIRCULAR CONNECTOR PLUG REPAIR.</u></b>		
<b>NOTE</b>		
Use this procedure to repair any one of the five connector plugs.		
18. Plug (18).	Unscrew and remove from item (19).	If item (18) is being replaced, repeat this step until all items (37) have been removed. Be sure to tag items (36). Refer to paragraphs 3-4 and 3-5. If any items (37) are damaged, do steps 21 and 22.
19. Pin (37).	Using item (39) or (40), pull out from rear side of item (18).	
20. All parts.	Clean and inspect.	Be careful not to damage item (37) during this step.
21. Pin (37).	Remove from item (36) and discard.	If item (18) is new, repeat this step until all items (37) have been installed. Check the mating side of item (18) to make sure all items (37) are on the same level.
22. New pin (37).	Using item (38), install onto item (36).	
23. Pin (37).	Push into rear end of item (18) until it snaps into place.	
24. Plug (18).	Line up slots with pins on item (19) and screw in until it clicks into place.	
<b>3-748</b>		

ELECTRICAL SYSTEM.

3-127. WIRING HARNESS REPAIR (Continued).

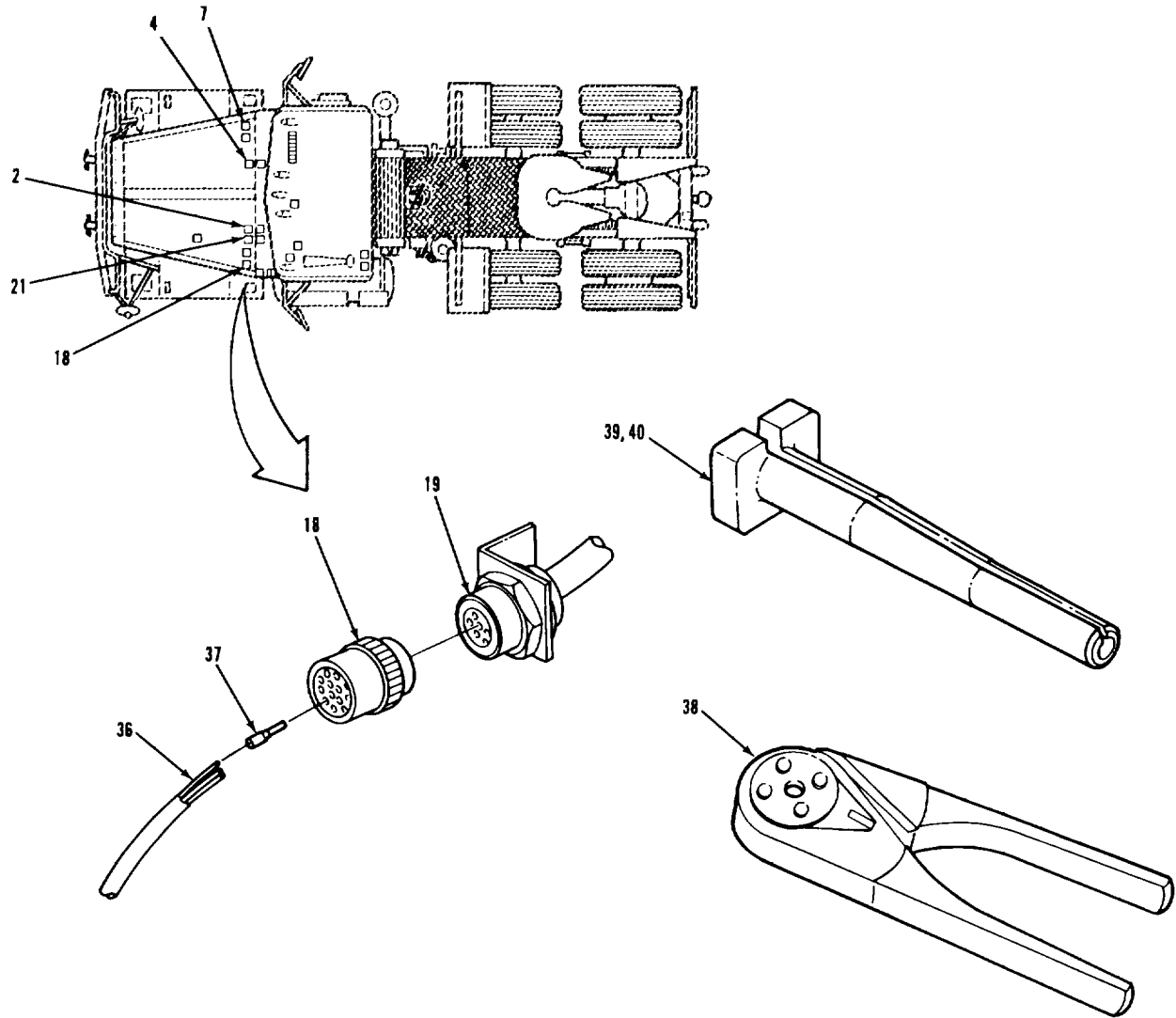

LEGEND:

- |   |   |
|---|---|
| 2. ENGINE HARNESS CONNECTOR PLUG                  | 19. LEFT-HAND FENDER HARNESS CONNECTOR RECEPTACLE |
| 4. FRONT CAB AND UNDERBODY HARNESS CONNECTOR PLUG | 21. CHASSIS HARNESS CONNECTOR PLUG                |
| 7. RIGHT-HAND FENDER HARNESS CONNECTOR PLUG       | 36. WIRE (as required)                            |
| 18. LEFT-HAND FENDER HARNESS CONNECTOR PLUG       | 37. TERMINAL PIN (as required)                    |
|   | 38. CRIMPING TOOL                                 |
|   | 39. CONTACT REMOVAL TOOL (size #12)               |
|   | 40. CONTACT REMOVAL TOOL (size #16)               |

TA 237348

**ELECTRICAL SYSTEM.**  
**3-127. WIRING HARNESS REPAIR (Continued).**

LOCATION/ITEM	ACTION	REMARKS
<b><u>C. CIRCULAR CONNECTOR RECEPTACLE REPAIR.</u></b>		
<b>NOTE</b>		
Use this procedure to repair any one of the five circular connector receptacles.		
25 Plug (18)	Unscrew and remove from item (19).	
26 Nut (41) and lockwasher (42)	Unscrew and remove from item (19).	
27 Receptacle (19)	Remove from item (43).	
28 Terminal (44)	Using item (39) or (40), pull out from rear side of item (19)	If item (19) is being replaced, repeat this step until all items (44) have been removed. Be sure to tag items (45).
29 All parts	Clean and inspect	Refer to paragraphs 3-4 and 3-5 If any items (44) are damaged, do steps 30 and 31.
30 Terminal (44)	Remove from item (45) and discard.	
<b>3-750</b>		

ELECTRICAL SYSTEM.

3-127. WIRING HARNESS REPAIR (Continued).

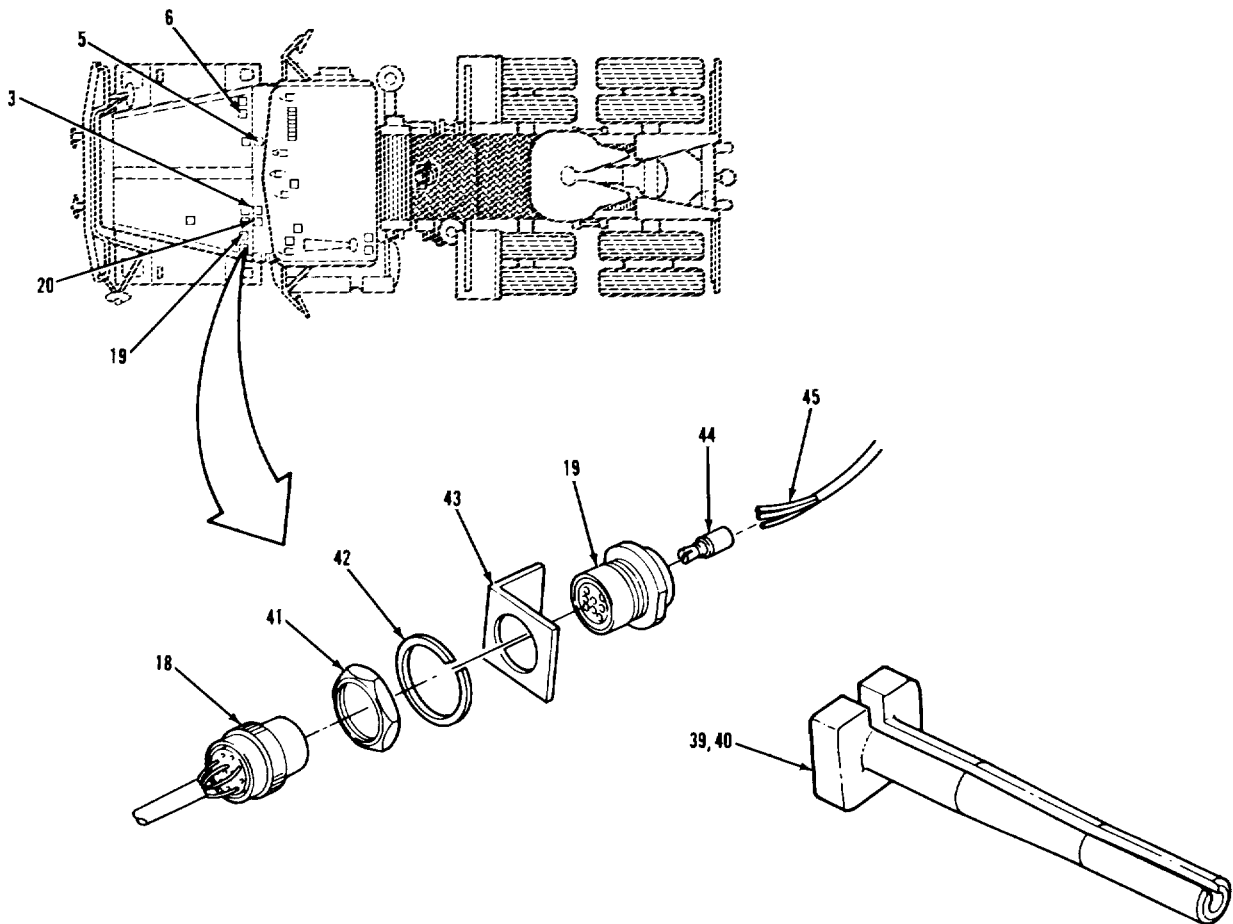

LEGEND:

- |   |  |
|---|--|
| 3. ENGINE HARNESS CONNECTOR RECEPTACLE                  | 20. CHASSIS HARNESS CONNECTOR RECEPTACLE |
| 5. FRONT CAB AND UNDERBODY HARNESS CONNECTOR RECEPTACLE | 39. CONTACT REMOVAL TOOL (size #12)      |
| 6. RIGHT-HAND FENDER HARNESS CONNECTOR RECEPTACLE       | 40. CONTACT REMOVAL TOOL (size #16)      |
| 18. LEFT-HAND FENDER HARNESS CONNECTOR PLUG             | 41. HEXAGON NUT                          |
| 19. LEFT-HAND FENDER HARNESS CONNECTOR RECEPTACLE       | 42. LOCKWASHER                           |
|   | 43. BRACKET                              |
|   | 44. TERMINAL (as required)               |
|   | 45. WIRE (as required)                   |

TA 237349

**ELECTRICAL SYSTEM.**

**3-127. WIRING HARNESS REPAIR (Continued).**

LOCATION/ITEM	ACTION	REMARKS
<b><u>C. CIRCULAR CONNECTOR RECEPTACLE REPAIR (Continued).</u></b>		
31. New terminal (44).	Using item (38), install onto item (45).	Be careful not to damage item (44) during this step.
32. Terminal (44).	Push into rear end of item (19) until it snaps into place.	If item (19) is new, repeat this step until all items (44) have been installed. Check the mating side of item (19) to make sure all items (44) are on the same level.
33. Receptacle (19)	<ul style="list-style-type: none"> <li>a. Position on item (43).</li> <li>b. Secure with items (41) and (42).</li> </ul>	
34. Plug (18).	Line up slots with pins on item (19) and screw on until it clicks into place.	
<b>3-752</b>		



ELECTRICAL SYSTEM.

3-127. WIRING HARNESS REPAIR (Continued).

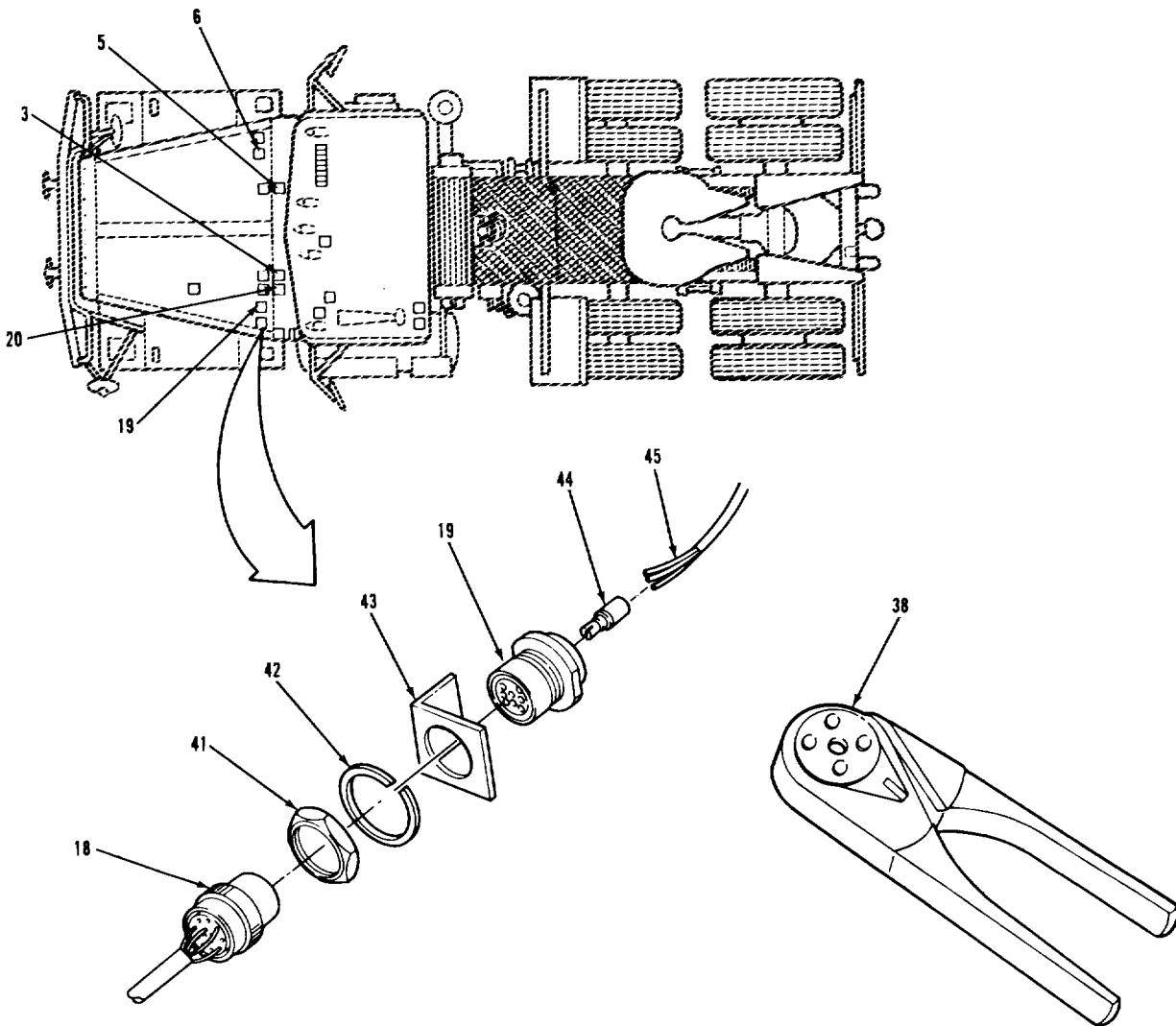

LEGEND:

- |   |  |
|---|--|
| 3. ENGINE HARNESS CONNECTOR RECEPTACLE                  | 20. CHASSIS HARNESS CONNECTOR RECEPTACLE |
| 5. FRONT CAB AND UNDERBODY HARNESS CONNECTOR RECEPTACLE | 38. CRIMPING TOOL                        |
| 6. RIGHT-HAND FENDER HARNESS CONNECTOR RECEPTACLE       | 41. HEXAGON NUT                          |
| 18. LEFT-HAND FENDER HARNESS CONNECTOR PLUG             | 42. LOCKWASHER                           |
| 19. LEFT-HAND FENDER HARNESS CONNECTOR RECEPTACLE       | 43. BRACKET                              |
|   | 44. TERMINAL (as required)               |
|   | 45. WIRE (as required)                   |

TA 237350

**ELECTRICAL SYSTEM.**

**3-127. WIRING HARNESS REPAIR (Continued).**

LOCATION/ITEM	ACTION	REMARKS
<b><u>D. RELAY CONNECTOR RECEPTACLE REPAIR.</u></b>		
<b>NOTE</b>		
Use this procedure to repair any one of the eight relay connector receptacles.		
35 Circuit breaker mounting bracket	Remove 3-114.	Refer to paragraph
36 Relay (46)	Remove from item (8) being repaired.	
37 Three relays (46)	Remove from first, fifth, and eighth items (8).	
38 Three screws (48) and eight receptacles (8).	Remove from item (47).	
39 Terminal (50)	Using small screwdriver, remove from rear end of item (8)	If item (8) is being replaced, repeat this step until all items (50) have been removed. Be sure to tag items (49).
40 All parts	Clean and inspect	Refer to paragraphs 3-4 and 3-5. Remove and replace any damaged items (50). Remove tape, and replace item (8), if damaged. Retape new item (8) to other seven items (8), as needed.
<b>3-754</b>		

ELECTRICAL SYSTEM.

3-127. WIRING HARNESS REPAIR (Continued).

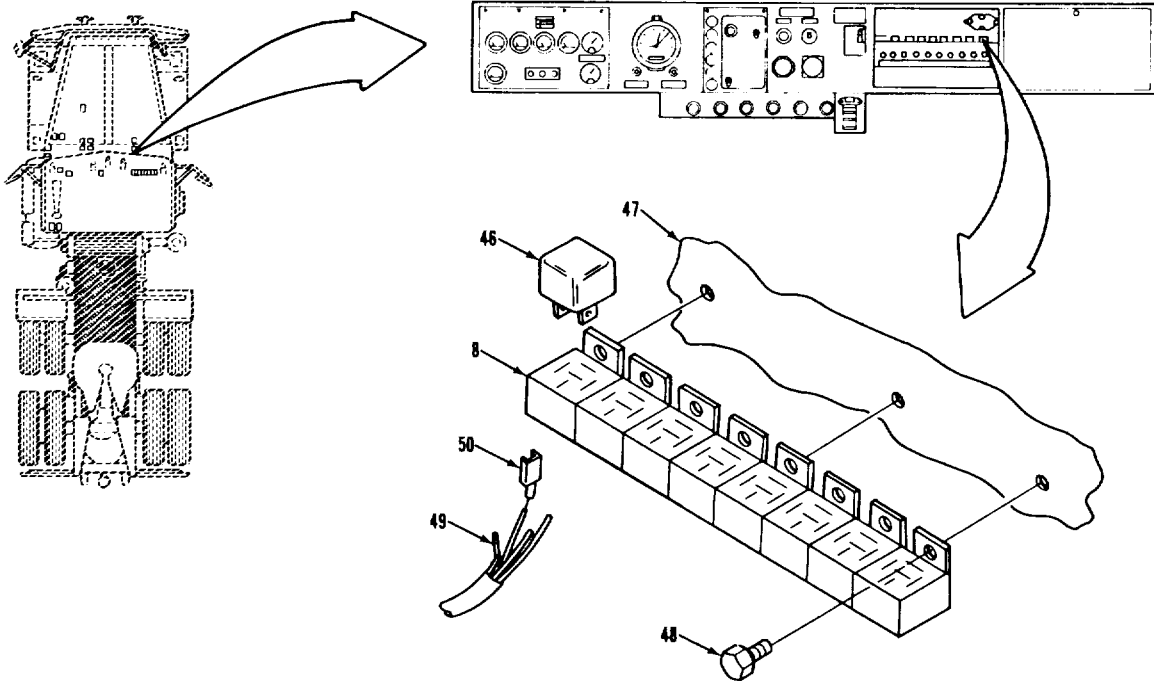

LEGEND:

- 8. RELAY CONNECTOR RECEPTACLE (8)
- 46. RELAY (8)
- 47. INSTRUMENT PANEL

- 48. SCREW (3)
- 49. WIRE (as required)
- 50. RELAY CONNECTOR TERMINAL (as required)

TA 237351

**ELECTRICAL SYSTEM.**

**3-127. WIRING HARNESS REPAIR (Continued).**

LOCATION/ITEM	ACTION	REMARKS
<b><u>D RELAY CONNECTOR RECEPTACLE REPAIR (Continued).</u></b>		
41. Terminal (50).	Push into rear of item (8) until it snaps in place.	If item (8) is new, repeat this step until all items (50) have been installed.
42. Eight receptacles	a. Position on item (47). b. Secure with three items (48).	
43. Four relays (46).	Install into four items (8).	
44. Circuit breaker mounting bracket.	Install.	Refer to paragraph 3-114.
<b>3-756</b>		

ELECTRICAL SYSTEM.

3-127. WIRING HARNESS REPAIR (Continued).

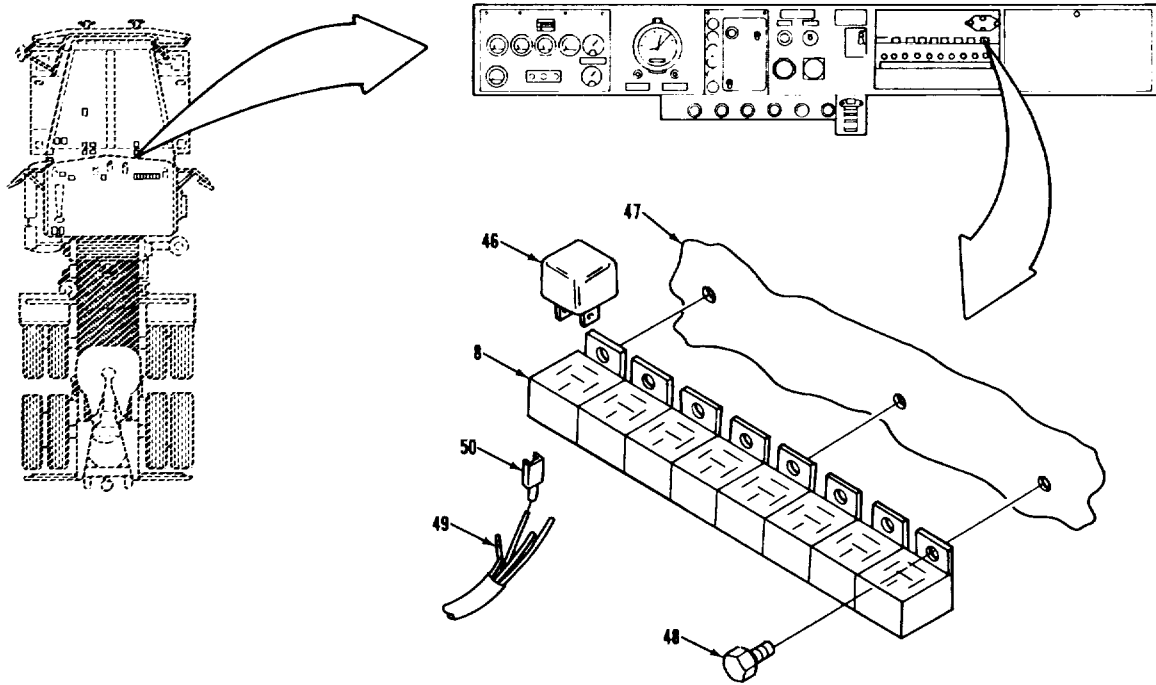

LEGEND:

- |                                   |  |
|-----------------------------------|--|
| 8. RELAY CONNECTOR RECEPTACLE (8) | 48. SCREW (3)                              |
| 46. RELAY (8)                     | 49. WIRE (as required)                     |
| 47. INSTRUMENT PANEL              | 50. RELAY CONNECTOR TERMINAL (as required) |

TA 237352

**ELECTRICAL SYSTEM.**  
**3-127. WIRING HARNESS REPAIR (Continued).**

LOCATION/ITEM	ACTION	REMARKS
<b><u>E. 24 VOLT CONNECTOR RECEPTACLE REPAIR. I</u></b>		
<p><b>NOTE</b>                      Use this procedure to repair any one of the two 24-volt connector receptacles.</p>		
45 Four screws (53), washers (56), nuts (57), and cover (52).	Remove from items (10) and (51).	
46 Receptacle (10)	Pull down and out of item (51) through slot.	
47 Nut (55)	Unscrew from item (10) and pull back onto items (58).	
48 All parts	Clean and inspect	Refer to paragraphs 3-4 and 3-5. Use standard shop maintenance procedures to replace any damaged parts.
49 Nut (55)	Screw onto item (10).	
50 Receptacle (10) and cover (52).	a Position on item (51).  b Secure with four items (53), (56), and (57).	
<b>3-758</b>		

ELECTRICAL SYSTEM.

3-127. WIRING HARNESS REPAIR (Continued).

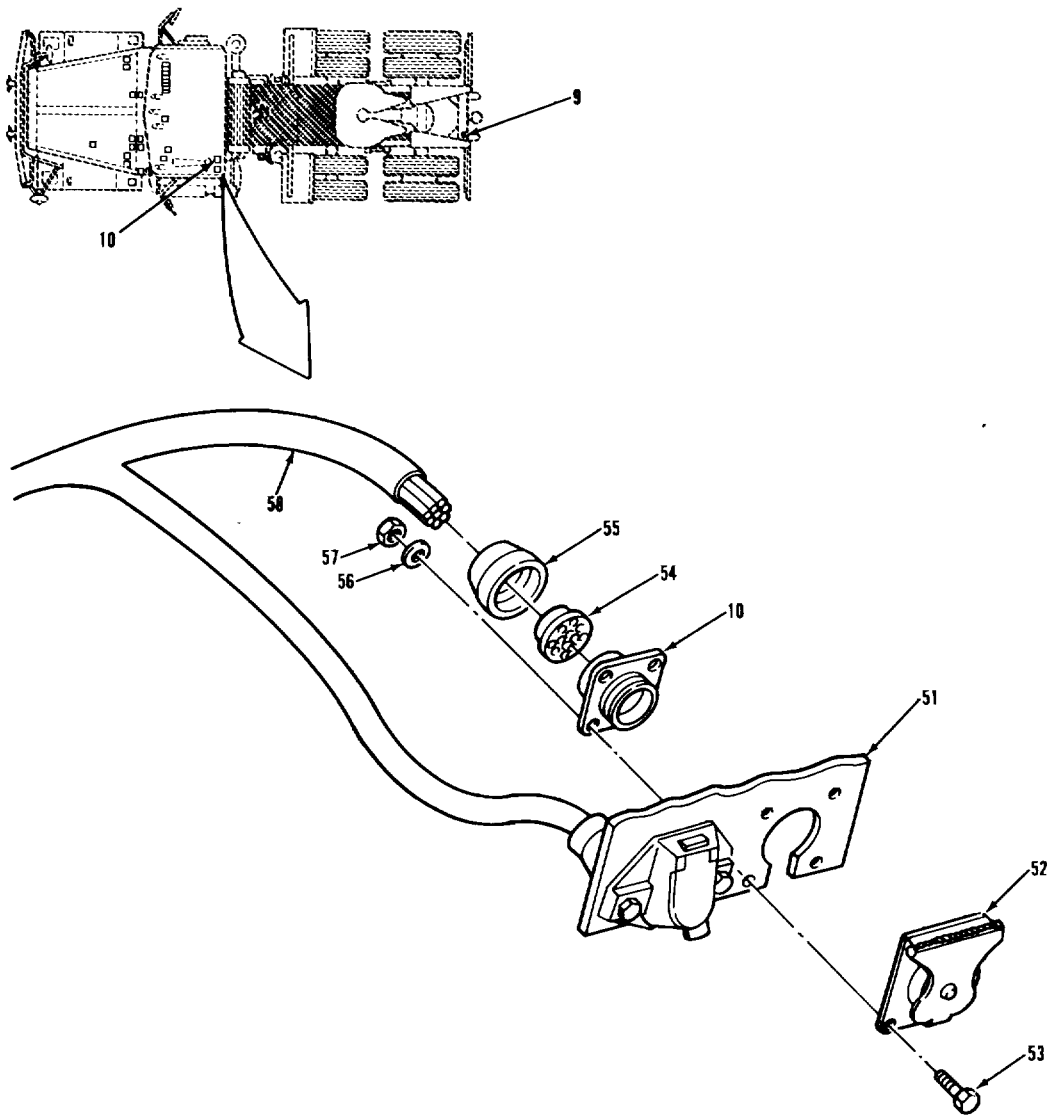

LEGEND:

- 9. 24-VOLT CONNECTOR RECEPTACLE
- 10. 24-VOLT CONNECTOR RECEPTACLE
- 51. BRACKET
- 52. COVER ASSEMBLY
- 53. HEXAGON BOLT (4)

- 54. GROMMET
- 55. 12-PIN NUT
- 56. FLAT WASHER (4)
- 57. NUT (4)
- 58. CHASSIS HARNESS ASSEMBLY

TA 237353

**ELECTRICAL SYSTEM.****3-127. WIRING HARNESS REPAIR (Continued).**

LOCATION/ITEM	ACTION	REMARKS
<b><u>F. 12 VOLT CONNECTOR RECEPTACLE REPAIR.</u></b>		
51 Boot (60)	Pull off of item (11) and onto item (58).	
52 Screw (61)	a Loosen, but do not remove. b Pull out item (59)	If item (11) is being replaced, repeat this step until all items (59) have been removed. Be sure to tag items (59).
53 Two screws (62), lockwashers (63), washers (64), nuts (65), and receptacle (11).	Remove from item (51)	Do this step only if replacing item (11).
54 All parts	Clean and inspect	Refer to paragraphs 3-4 and 3-5. Remove and replace item (60), if damaged.
55 Receptacle (11)	a Position on item (51). b Secure with two items (62), (63), (64), and (65).	
56 Wire (59)	a Position in item (11). b Secure with item (61)	If item (11) is new, repeat this step until all items (59) have been installed.
57 Boot (60)	Push onto item (11).	
<b>3-760</b>		



ELECTRICAL SYSTEM.

3-127. WIRING HARNESS REPAIR (Continued).

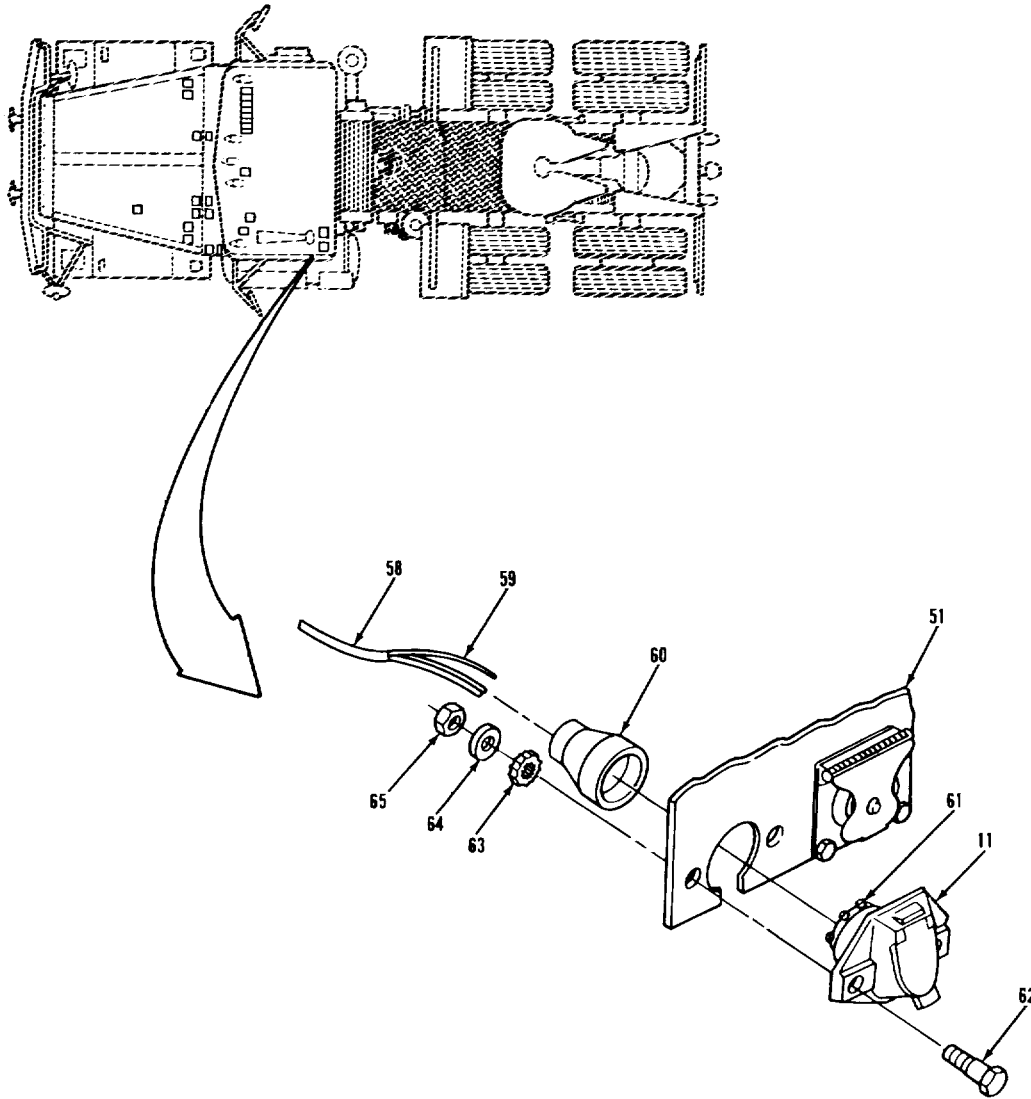

LÉGEND:

- 11. 12-VOLT CONNECTOR RECEPTACLE
- 51. BRACKET
- 58. CHASSIS HARNESS ASSEMBLY
- 59. WIRE (6)
- 60. 7-PIN RECEPTACLE BOOT

- 61. SCREW (6)
- 62. HEXAGON (2)
- 63. LOCKWASHER (2)
- 64. FLAT WASHER (2)
- 65. NUT (2)

TA 237354

**ELECTRICAL SYSTEM.**  
**3-127. WIRING HARNESS REPAIR (Continued).**

LOCATION/ITEM	ACTION	REMARKS
<b><u>G. PLASTIC CONNECTOR RECEPTACLE OR PLUG REPAIR.</u></b>		
<b>NOTE</b>		
Use this procedure to repair any one of the five plastic connector receptacles or plugs.		
58 Receptacle (16) 59 Terminal (66)	Pull off of item (15). Using small screwdriver, remove from rear end of item (16)	If item (16) is being replaced, repeat this step until all items (66) have been removed. Be sure to tag all items (67).
60 All parts	Clean and inspect	Refer to paragraphs 3-4 and 3-5. Remove and replace any damaged items (66).
61 Terminal (66)	Push into rear of item (16) until it snaps in place	If item (16) is new, re- peat this step until all items (66) have been installed.
62 Receptacle (16)	Push onto item (15).	
<b>3-762</b>		

ELECTRICAL SYSTEM.

3-127. WIRING HARNESS REPAIR (Continued).

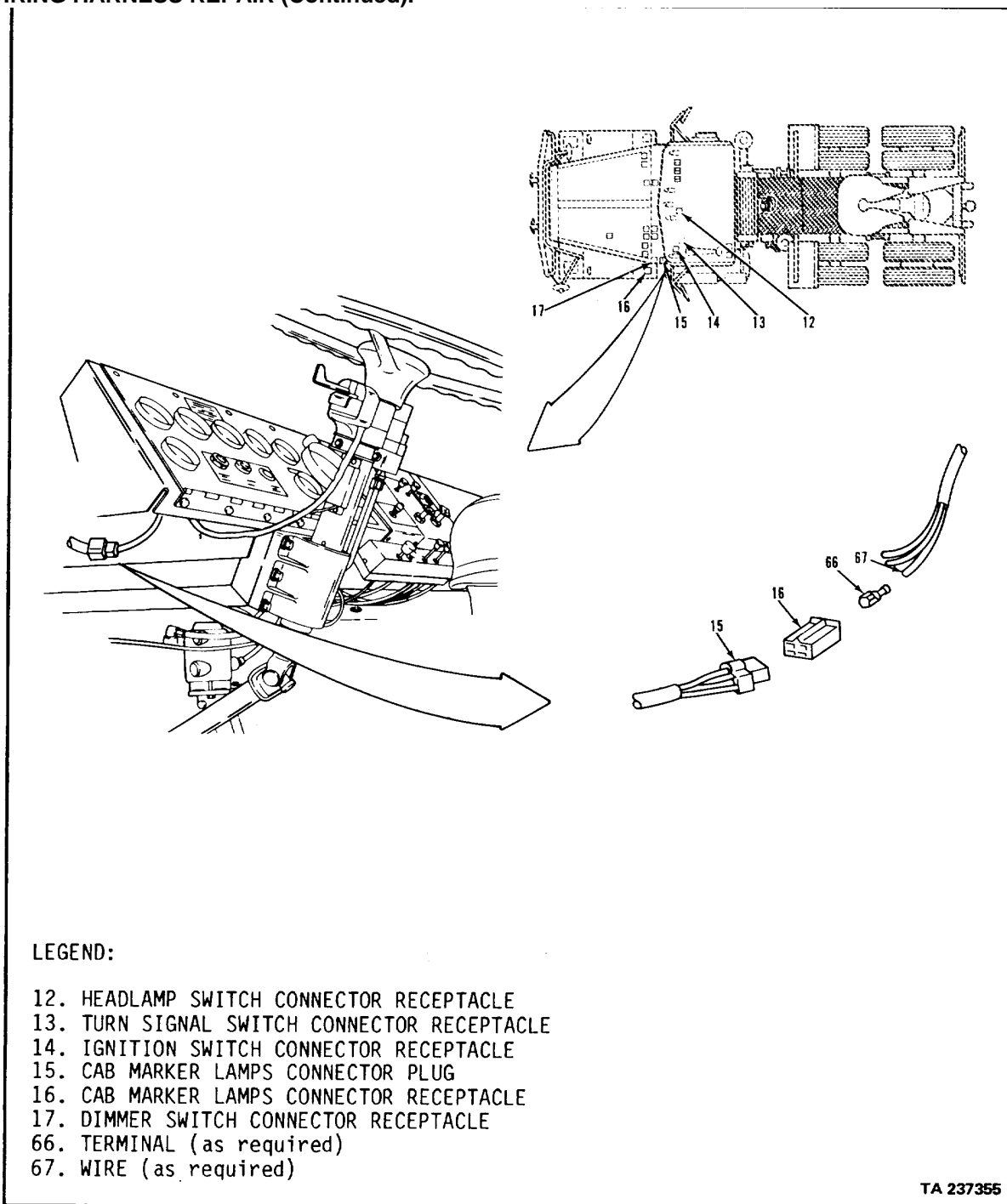

TA 237355

ELECTRICAL SYSTEM.

3-127. WIRING HARNESS REPAIR (Continued).

LOCATION / ITEM	ACTION	REMARKS
-----------------	--------	---------

H. WIRE REPLACEMENT.

**NOTE**

**Use this procedure to replace any damaged wire.  
Typical wire replacement is shown.**

- |                    |  |
|--------------------|--|
| 65. Wire (69).     | <ul style="list-style-type: none"> <li>a. Remove ends from terminal or connector.</li> <li>b. Cut off and insulate ends with suitable tape.</li> </ul>   |
| 66. New wire (69). | <ul style="list-style-type: none"> <li>a. Measure length of wire route, and cut to length.</li> <li>b. Secure one end to proper terminal or connector.</li> <li>c. Position along item (68), and screw in place on other terminal or connector.</li> <li>d. Using suitable tape, secure to item (68).</li> </ul> |

**NOTE**

**Follow-on maintenance action required:  
Connect battery power (para 3-120).**

ELECTRICAL SYSTEM.

3-127. WIRING HARNESS REPAIR (Continued).

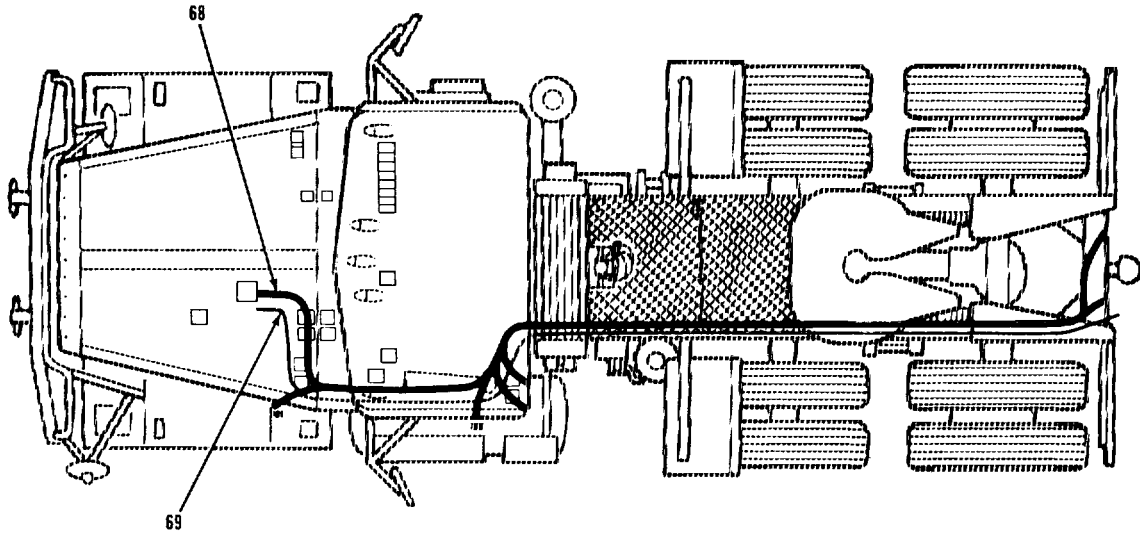

LEGEND:

- 68. CHASSIS HARNESS ASSEMBLY
- 69. WIRE

TA 237356

**ELECTRICAL SYSTEM.**

**3-128. GROUND STRAP AND CABLES REPLACEMENT.**

**THIS TASK COVERS**

- a. Starter Ground Strap Removal.
- b. Starter Ground Strap Installation.
- c. Engine to Frame Ground Cable Removal.
- d. Engine to Frame Ground Cable Installation.
- e. Cab to Frame Ground Cable Removal.
- f. Cab to Frame Ground Cable Installation.

**INITIAL SETUP**

<u>APPLICABLE CONFIGURATIONS</u> All.	<u>EQUIPMENT CONDITION PARAGRAPH</u> None.	<u>CONDITION DESCRIPTION</u> None.
--	---	---------------------------------------

TEST EQUIPMENT  
None.

SPECIAL TOOLS -  
None.

MATERIALS/PARTS (P/N)  
None.

PERSONNEL REQUIRED  
One (MOS-63S).

SPECIAL ENVIRONMENTAL CONDITIONS  
None.

REFERENCES (TM)  
None.

GENERAL SAFETY INSTRUCTIONS  
Engine off.  
Park brake set.  
Transmission in neutral.

TROUBLESHOOTING REFERENCES  
Paragraph 2-11.

ELECTRICAL SYSTEM.

3-128. GROUND STRAP AND CABLES REPLACEMENT (Continued).

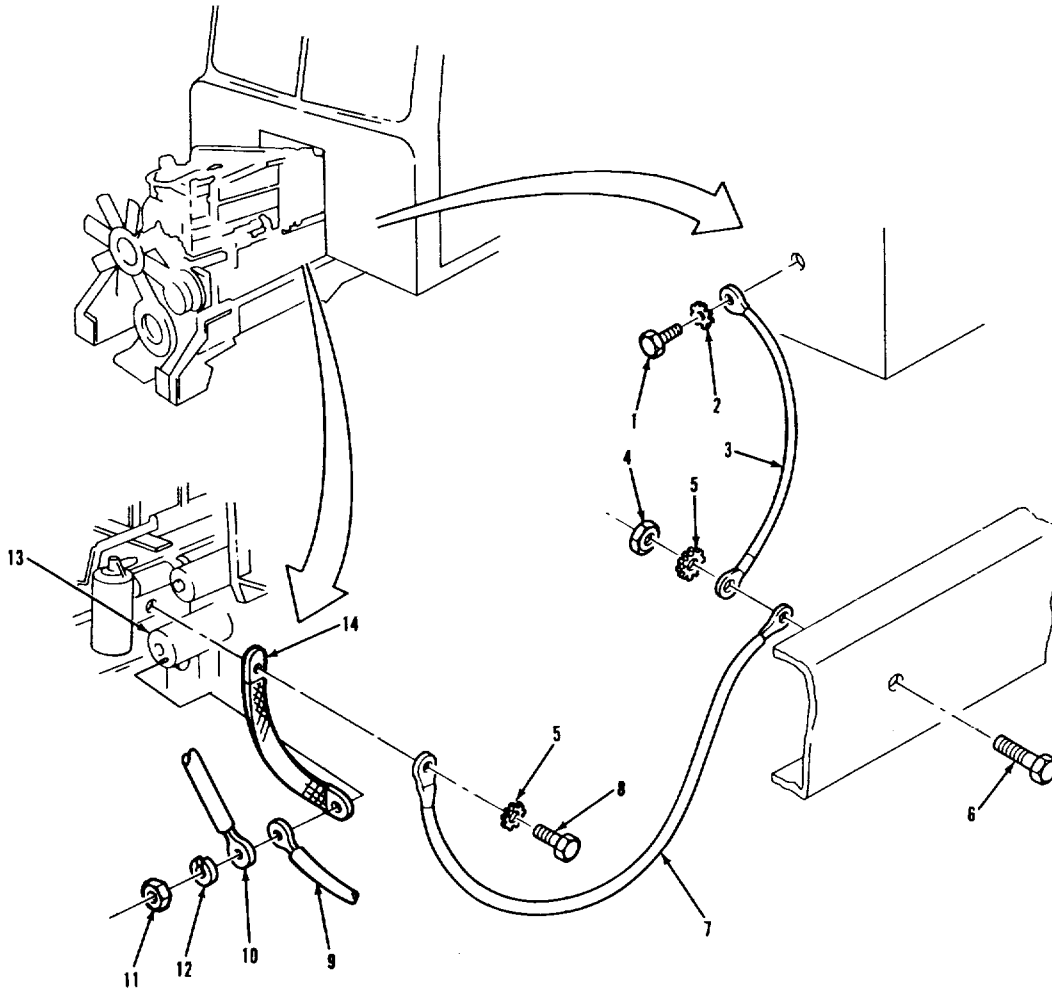

LEGEND:

- |                                     |  |
|-------------------------------------|--|
| 1. TAPPING SCREW                    | 9. NEGATIVE BATTERY POWER CABLE ASSEMBLY |
| 2. WASHER                           | 10. WIRE (98K)                           |
| 3. CAB TO FRAME GROUND CABLE        | 11. HEX NUT                              |
| 4. HEX NUT                          | 12. LOCKWASHER                           |
| 5. INTERNAL/EXTERNAL LOCKWASHER (2) | 13. STARTER MOTOR                        |
| 6. SCREW                            | 14. STARTER GROUND STRAP                 |
| 7. ENGINE TO FRAME GROUND CABLE     |  |
| 8. HEXAGON BOLT                     |  |

TA 237357

## ELECTRICAL SYSTEM.

## 3-128. GROUND STRAP AND CABLES REPLACEMENT (Continued).

LOCATION / ITEM	ACTION	REMARKS
A. <u>STARTER GROUND STRAP REMOVAL.</u>		
1. Nut (11), lock-washer (12), wire (10), cable assembly (9), and strap (14).	Remove from item (13).	
2. Bolt (8) and lockwasher (5).	Remove from item (7) and item (14).	
B. <u>STARTER GROUND STRAP INSTALLATION.</u>		
3. Bolt (8) and lockwasher (5).	Secure item (7) and item (14) to engine.	
4. Strap (14), cable assembly (9), and wire (10).	Install on item (13).	
5. Nut (11) and lockwasher (12).	Secure item (10), item (9), and item (14) to item (13).	
C. <u>ENGINE TO FRAME GROUND CABLE REMOVAL.</u>		
6. Bolt (8) and lockwasher (5).	Remove from item (7) and item (14).	
7. Screw (6), lock-washer (5), and nut (4).	Remove from item (7) and item (3).	



ELECTRICAL SYSTEM.

3-128. GROUND STRAP AND CABLES REPLACEMENT (Continued),

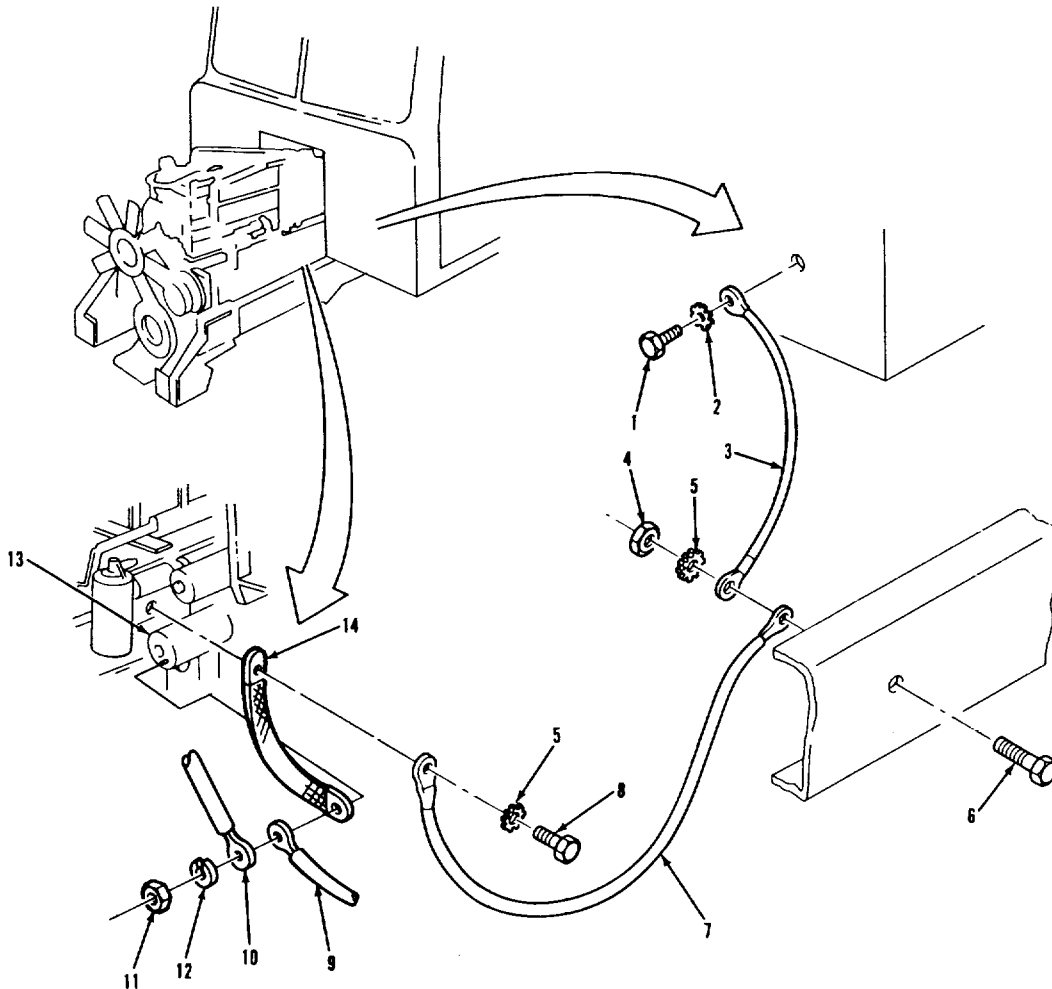

LEGEND:

- |                                     |  |
|-------------------------------------|--|
| 1. TAPPING SCREW                    | 9. NEGATIVE BATTERY POWER CABLE ASSEMBLY |
| 2. WASHER                           | 10. WIRE (98K)                           |
| 3. CAB TO FRAME GROUND CABLE        | 11. HEX NUT                              |
| 4. HEX NUT                          | 12. LOCKWASHER                           |
| 5. INTERNAL/EXTERNAL LOCKWASHER (2) | 13. STARTER MOTOR                        |
| 6. SCREW                            | 14. STARTER GROUND STRAP                 |
| 7. ENGINE TO FRAME GROUND CABLE     |  |
| 8. HEXAGON BOLT                     |  |

TA 237357

## ELECTRICAL SYSTEM.

## 3-128. GROUND STRAP AND CABLES REPLACEMENT (Continued).

LOCATION / ITEM	ACTION	REMARKS
D. <u>ENGINE TO FRAME GROUND CABLE INSTALLATION.</u>		
8. Screw (6), lock-washer (5), and nut (4).	Secure item (7) and item (3) to frame.	
9. Bolt (8) and lockwasher (5).	Secure item (7) and item (14) to engine.	
E. <u>CAB TO FRAME GROUND CABLE REMOVAL.</u>		
10. Screw (6), lock-washer (5), and nut (4).	Remove from item (3) and item (7).	
11. Screw (1) and washer (2).	Remove from item (3).	
F. <u>CAB TO FRAME GROUND CABLE INSTALLATION.</u>		
12. Screw (1) and washer (2).	Secure item (3) to cab.	
13. Screw (6), lock-washer (5), and nut (4).	Secure item (3) and item (7) to frame.	

**NOTE****Follow-on maintenance action required:**

None.

**3-770**

ELECTRICAL SYSTEM.

3-128. GROUND STRAP AND CABLES REPLACEMENT (Continued).

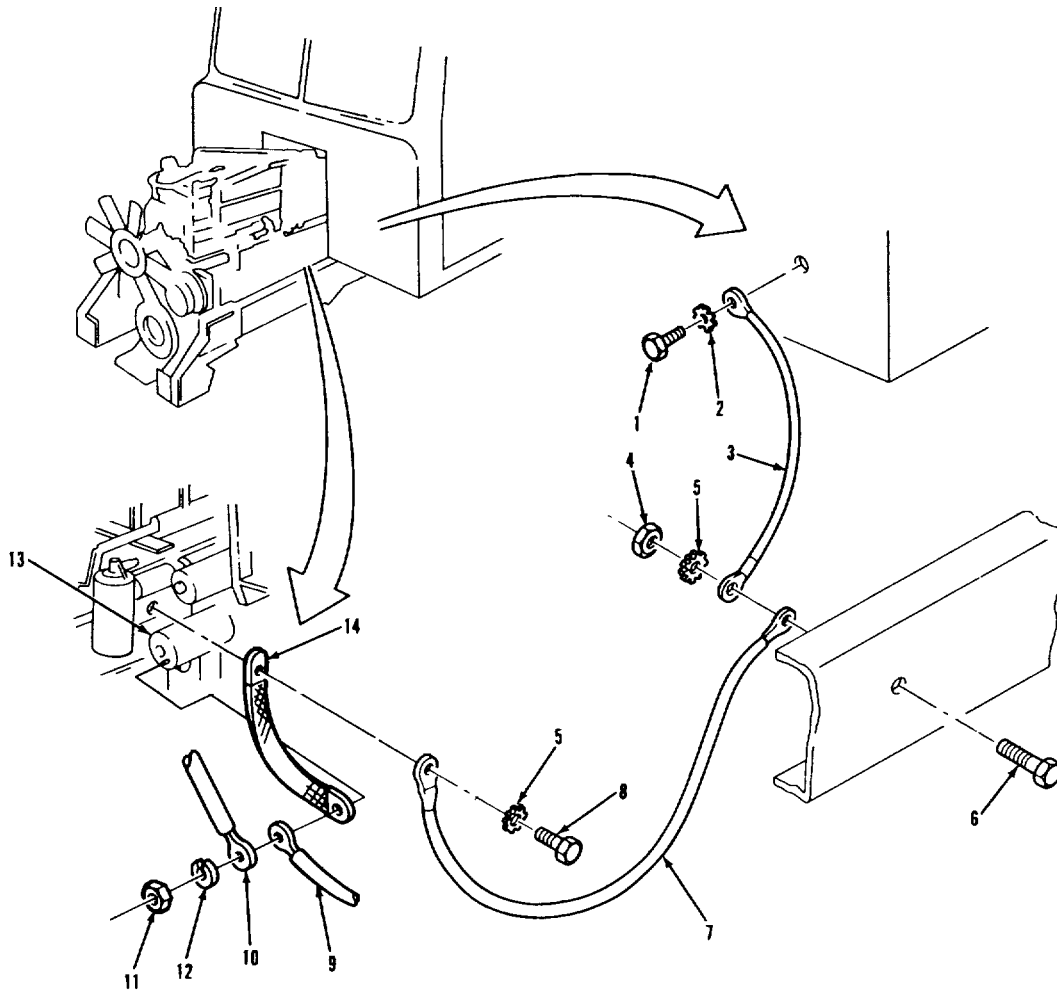

LEGEND:

- |                                     |  |
|-------------------------------------|--|
| 1. TAPPING SCREW                    | 9. NEGATIVE BATTERY POWER CABLE ASSEMBLY |
| 2. WASHER                           | 10. WIRE (98K)                           |
| 3. CAB TO FRAME GROUND CABLE        | 11. HEX NUT                              |
| 4. HEX NUT                          | 12. LOCKWASHER                           |
| 5. INTERNAL/EXTERNAL LOCKWASHER (2) | 13. STARTER MOTOR                        |
| 6. SCREW                            | 14. STARTER GROUND STRAP                 |
| 7. ENGINE TO FRAME GROUND CABLE     |  |
| 8. HEXAGON BOLT                     |  |

TA 237358

**ELECTRICAL SYSTEM.**

**3-129. BLACKOUT MARKER LAMP AND HEADLAMP CABLE REPLACEMENT.**

THIS TASK COVERS

- |                               |                                    |
|-------------------------------|------------------------------------|
| a. Access Cable.              | d. Headlamp Cable Installation.    |
| b. Marker Lamp Cable Removal. | e. Marker Lamp Cable Installation. |
| c. Headlamp Cable Removal.    | f. Headlamp Assembly Installation. |

INITIAL SETUP

APPLICABLE CONFIGURATIONS  
All.

EQUIPMENT CONDITION  
PARAGRAPH  
3-120.

CONDITION DESCRIPTION  
Battery power  
disconnected.

TEST EQUIPMENT  
None.

SPECIAL TOOLS  
None.

MATERIALS/PARTS (P/N)  
None.

PERSONNEL REQUIRED  
One (MOS-63S).

SPECIAL ENVIRONMENTAL CONDITIONS  
None.

REFERENCES (TM)  
None.

GENERAL SAFETY INSTRUCTIONS  
Engine off.  
Transmission in neutral.  
Park brake set.

TROUBLESHOOTING REFERENCES  
Paragraph 2-11.

ELECTRICAL SYSTEM.

3-129. BLACKOUT MARKER LAMP AND HEADLAMP CABLE REPLACEMENT (Continued).

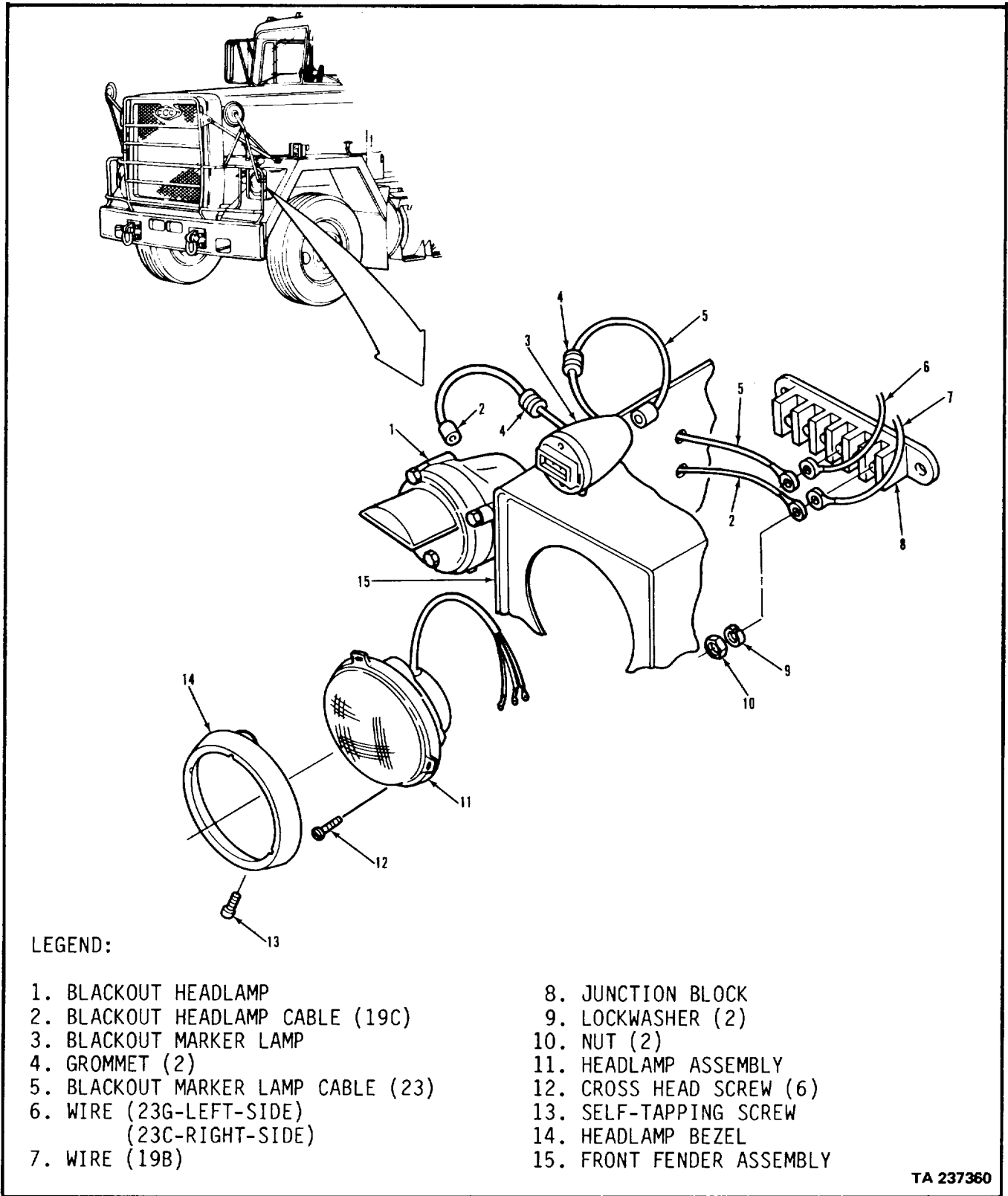

TA 237360

## ELECTRICAL SYSTEM.

## 3-129. BLACKOUT MARKER LAMP AND HEADLAMP CABLE REPLACEMENT (Continued).

LOCATION / ITEM	ACTION	REMARKS
-----------------	--------	---------

**NOTE**

**Replacement of blackout marker lamp cable is the same for both sides.**

A. ACCESS CABLE.

- |                            |                           |
|----------------------------|---------------------------|
| 1. Screw (13).             | Remove from item (14).    |
| 2. Bezel (14).             | Remove from item (11).    |
| 3. Six screws (12).        | Remove from item (11).    |
| 4. Headlamp assembly (11). | Set aside out of the way. |

B. MARKER LAMP CABLE REMOVAL.

- |   |                        |
|---|------------------------|
| 5. Nut (10), washer (9), wire (6), and cable (5). | Remove from item (8).  |
| 6. Cable (5).                                     | Pull from item (3).    |
| 7. Cable (5) and grommet (4).                     | Remove from item (15). |
| 8. Grommet (4).                                   | Remove from item (5).  |

C. HEADLAMP CABLE REMOVAL.

- |   |                        |
|---|------------------------|
| 9. Nut (10), washer (9), wire (7), and cable (2). | Remove from item (8).  |
| 10. Cable (2).                                    | Pull from item (1).    |
| 11. Cable (2) and grommet (4).                    | Remove from item (15). |
| 12. Grommet (4).                                  | Remove from item (2).  |

ELECTRICAL SYSTEM.

3-129. BLACKOUT MARKER LAMP AND HEADLAMP CABLE REPLACEMENT (Continued).

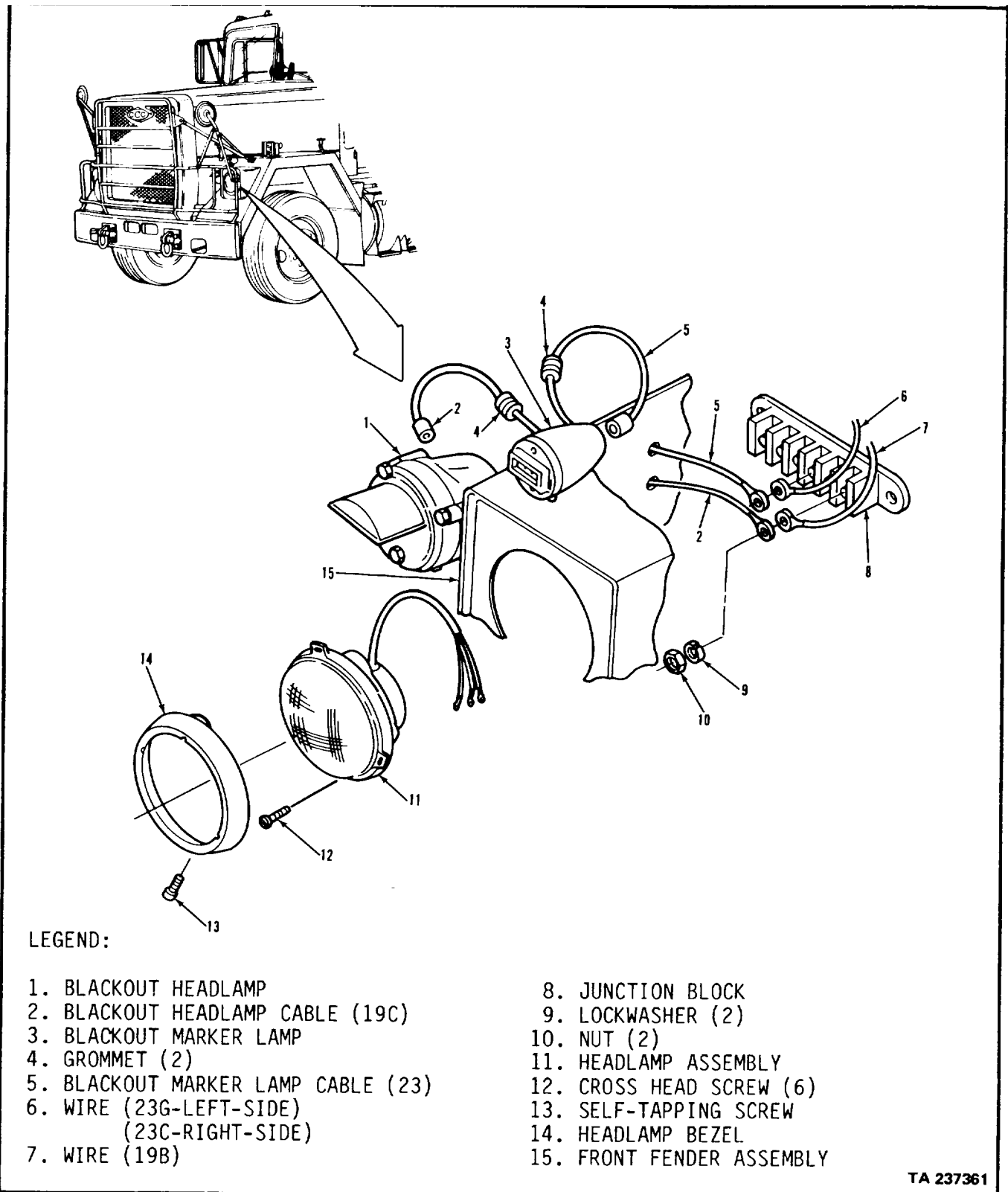

TA 237361

## ELECTRICAL SYSTEM.

## 3-129. BLACKOUT MARKER LAMP AND HEADLAMP CABLE REPLACEMENT (Continued).

LOCATION / ITEM	ACTION	REMARKS
D. <u>HEADLAMP CABLE INSTALLATION.</u>		
13. Grommet (4).	Put on item (2).	
14. Grommet (4) and cable (2).	Put in place through item (15).	
15. Nut (10) and washer (9).	Secure item (7) and item (2) to item (8).	
16. Cable (2).	Plug into item (1).	
E. <u>MARKER LAMP CABLE INSTALLATION.</u>		
17. Grommet (4).	Put on item (5).	
18. Grommet (4) and cable (5).	Put in place through item (15).	
19. Nut (10) and washer (9).	Secure item (6) and item (5) to item (8).	
20. Cable (5).	Plug into item (3).	
F. <u>HEADLAMP ASSEMBLY INSTALLATION.</u>		
21. Headlamp assembly (11).	Put in place in item (15).	
22. Six screws (12).	Secure item (11) to item (15).	
23. Bezel (14).	Put in place on item (11).	
24. Screw (13).	Secure item (14) to item (11).	

**NOTE**

**Follow-on maintenance action required:**

**Connect battery power (para 3-120).**



ELECTRICAL SYSTEM.

3-129. BLACKOUT MARKER LAMP AND HEADLAMP CABLE REPLACEMENT (Continued).

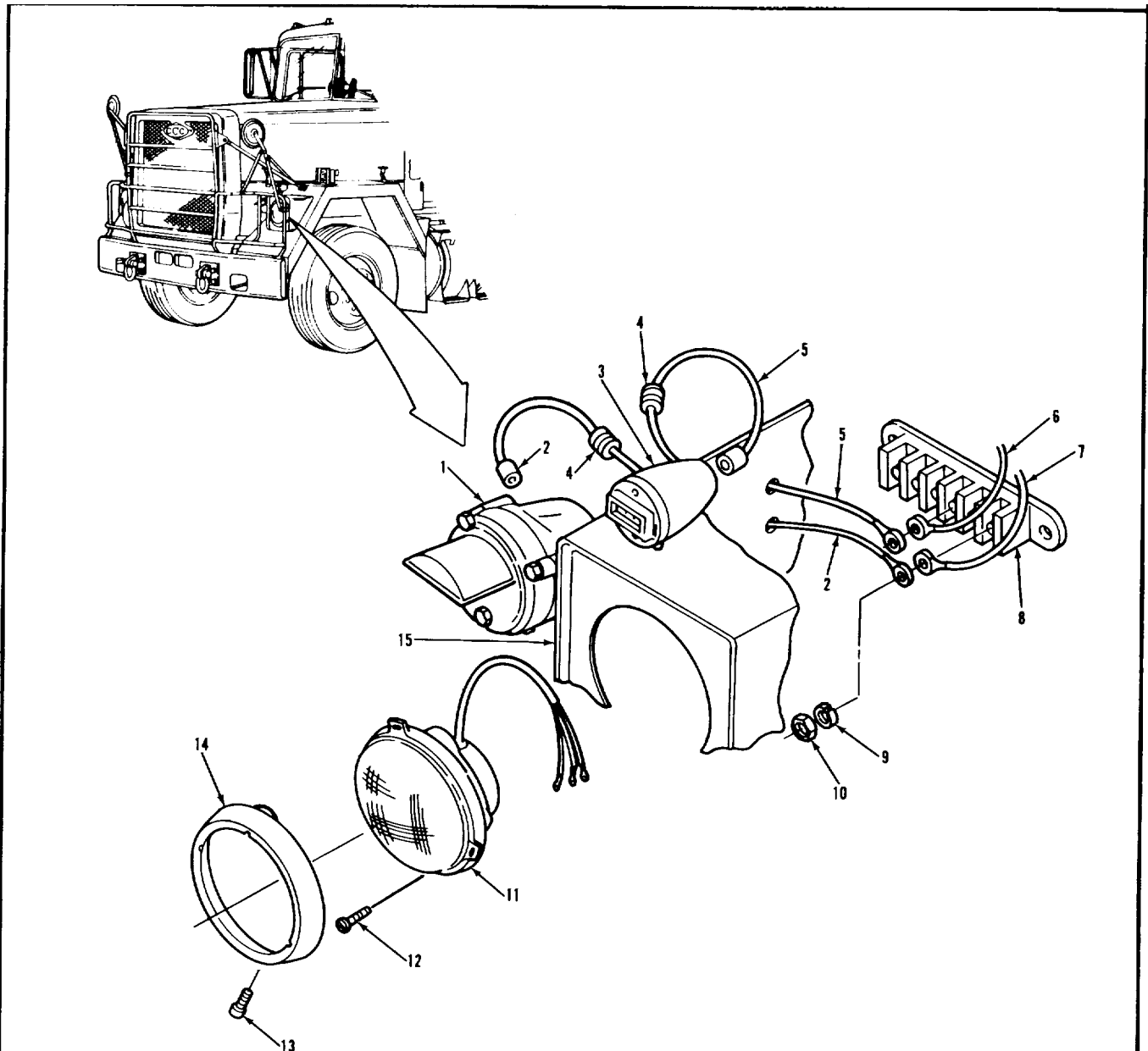

LEGEND:

- |                                    |                           |
|------------------------------------|---------------------------|
| 1. BLACKOUT HEADLAMP               | 8. JUNCTION BLOCK         |
| 2. BLACKOUT HEADLAMP CABLE (19C)   | 9. LOCKWASHER (2)         |
| 3. BLACKOUT MARKER LAMP            | 10. NUT (2)               |
| 4. GROMMET (2)                     | 11. HEADLAMP ASSEMBLY     |
| 5. BLACKOUT MARKER LAMP CABLE (23) | 12. CROSS HEAD SCREW (6)  |
| 6. WIRE (23G-LEFT-SIDE)            | 13. SELF-TAPPING SCREW    |
| 7. WIRE (19B)                      | 14. HEADLAMP BEZEL        |
|                                    | 15. FRONT FENDER ASSEMBLY |

TA 237362

**ELECTRICAL SYSTEM.**

**3-130. TRAILER RECEPTACLE BRACKET REPLACEMENT.**

**THIS TASK COVERS**

- a. Removal of Cab Mounted Bracket and Cover.
- b. Installation of Cab Mounted Bracket and Cover.
- c. Removal of Rear Cover.
- d. Installation of Rear Cover.

**INITIAL SETUP**

<p><u>APPLICABLE CONFIGURATIONS</u> All.</p>	<p><u>EQUIPMENT CONDITION PARAGRAPH</u> None.</p>	<p><u>CONDITION DESCRIPTION</u> None.</p>
<p><u>TEST EQUIPMENT</u> None.</p>		
<p><u>SPECIAL TOOLS</u> None.</p>		
<p><u>MATERIALS/PARTS (P/N)</u> None.</p>		
<p><u>PERSONNEL REQUIRED</u> One (MOS-63S).</p>	<p><u>SPECIAL ENVIRONMENTAL CONDITIONS</u> None.</p>	
<p><u>REFERENCES (TM)</u> None.</p>	<p><u>GENERAL SAFETY INSTRUCTIONS</u> Engine off. Transmission in neutral. Park brake set.</p>	
<p><u>TROUBLESHOOTING REFERENCES</u> None.</p>		

ELECTRICAL SYSTEM.

3-130. TRAILER RECEPTACLE BRACKET REPLACEMENT (Continued).

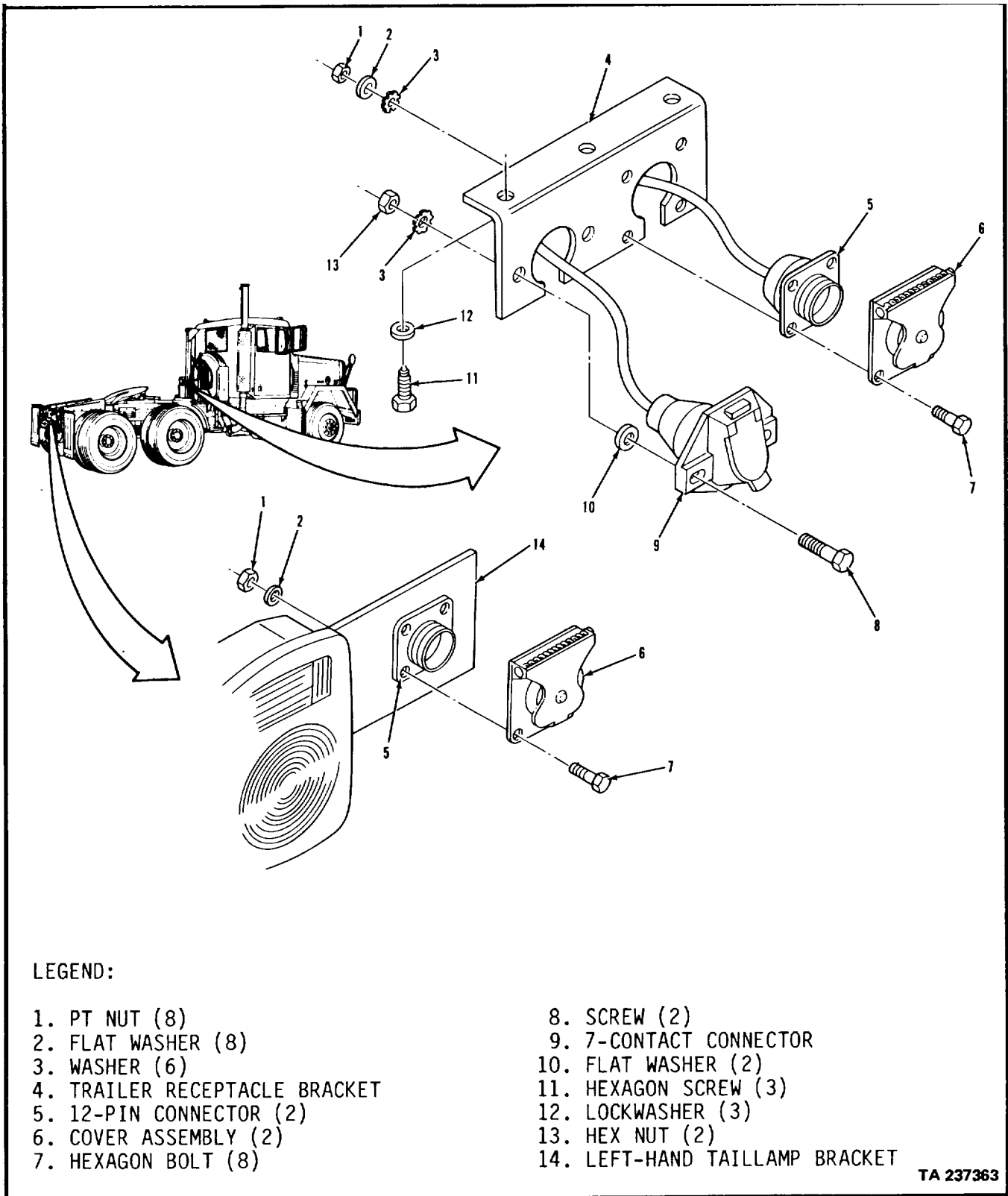

## ELECTRICAL SYSTEM.

## 3-130. TRAILER RECEPTACLE BRACKET REPLACEMENT (Continued).

LOCATION / ITEM	ACTION	REMARKS
A. <u>REMOVAL OF CAB MOUNTED BRACKET AND COVER.</u>		
1. Two screws (8), washers (10), washers (3), and nuts (13).	Remove from item (9) and item (4).	
2. Four screws (7), washers (3), washers (2), and nuts (1).	Remove from item (6), item (5), and item (4).	
3. Connectors (9) and (5), and cover (6).	Remove from item (4).	
4. Three screws (11) and lock-washers (12).	Remove from item (4).	
B. <u>INSTALLATION OF CAB MOUNTED BRACKET AND COVER.</u>		
5. Bracket (4).	Put in place under cab.	
6. Three screws (11) and lock-washers (12).	Secure item (4) to cab.	
7. Connectors (9) and (5) and cover (6).	Put in place on item (4).	
8. Four screws (7), washers (3), washers (2), and nuts (1).	Secure item (6) and item (5) to item (4).	
9. Two screws (8), washers (10), washers (3) and nuts (13).	Secure item (9) to item (4).	

ELECTRICAL SYSTEM.

3-130. TRAILER RECEPTACLE BRACKET REPLACEMENT (Continued).

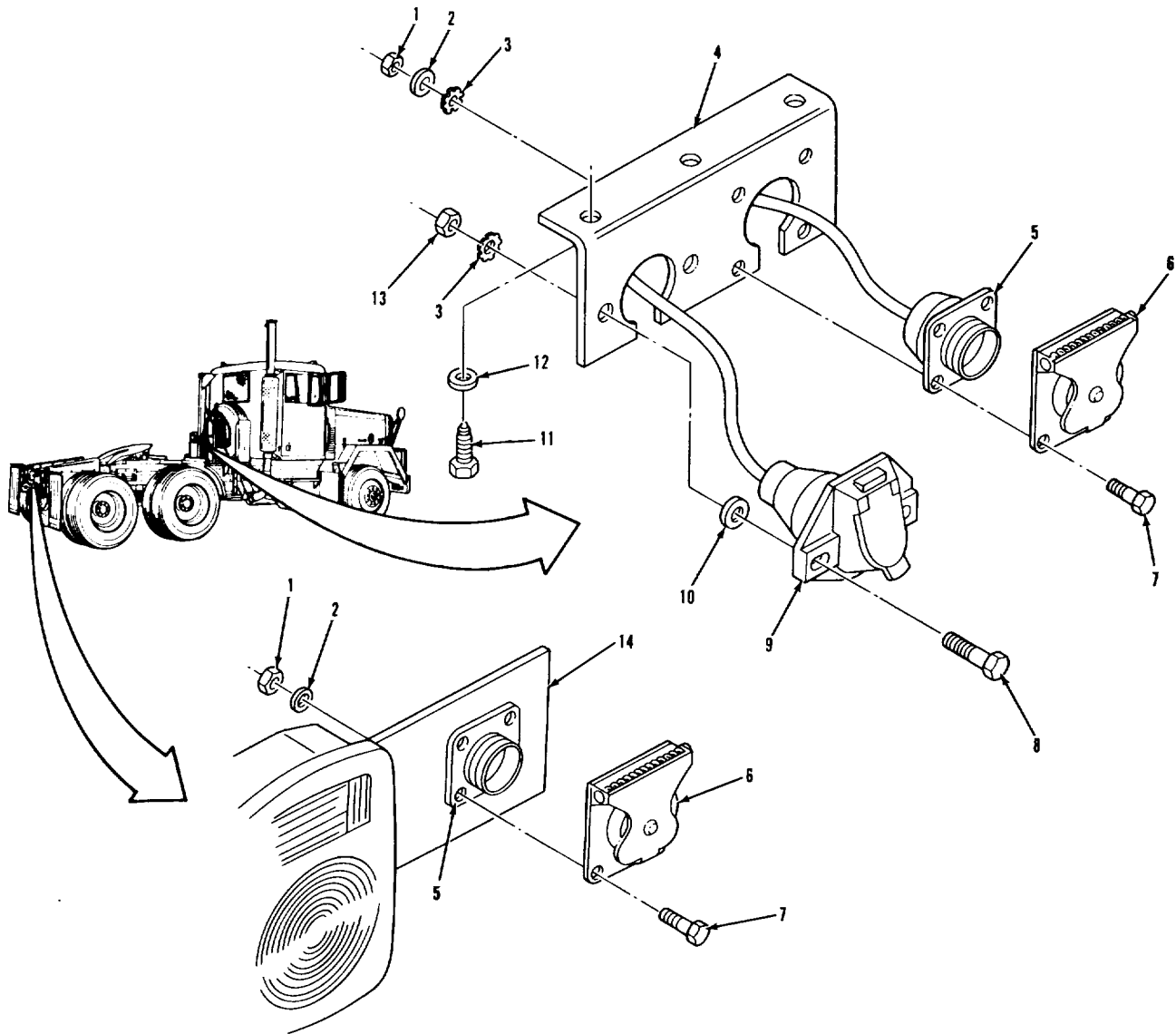

LEGEND:

- |                               |                                |
|-------------------------------|--------------------------------|
| 1. PT NUT (8)                 | 8. SCREW (2)                   |
| 2. FLAT WASHER (8)            | 9. 7-CONTACT CONNECTOR         |
| 3. WASHER (6)                 | 10. FLAT WASHER (2)            |
| 4. TRAILER RECEPTACLE BRACKET | 11. HEXAGON SCREW (3)          |
| 5. 12-PIN CONNECTOR (2)       | 12. LOCKWASHER (3)             |
| 6. COVER ASSEMBLY (2)         | 13. HEX NUT (2)                |
| 7. HEXAGON BOLT (8)           | 14. LEFT-HAND TAILLAMP BRACKET |

TA 237364

**ELECTRICAL SYSTEM.****3-130. TRAILER RECEPTACLE BRACKET REPLACEMENT (Continued).**

LOCATION / ITEM	ACTION	REMARKS
C. <u>REMOVAL OF REAR COVER.</u>		
10. Four screws (7), washers (2), and nuts (1).	Remove from item (6).	
11. Cover (6).	Remove from item (5).	
D. <u>INSTALLATION OF REAR COVER.</u>		
12. Cover (6).	Put in place over item (5).	
13. Four screws (7), washers (2), and nuts (1).	Secure item (6) and item (5) to item (14).	

**NOTE****Follow-on maintenance action required:**

None.

**3-782**

ELECTRICAL SYSTEM.

3-130. TRAILER RECEPTACLE BRACKET REPLACEMENT (Continued).

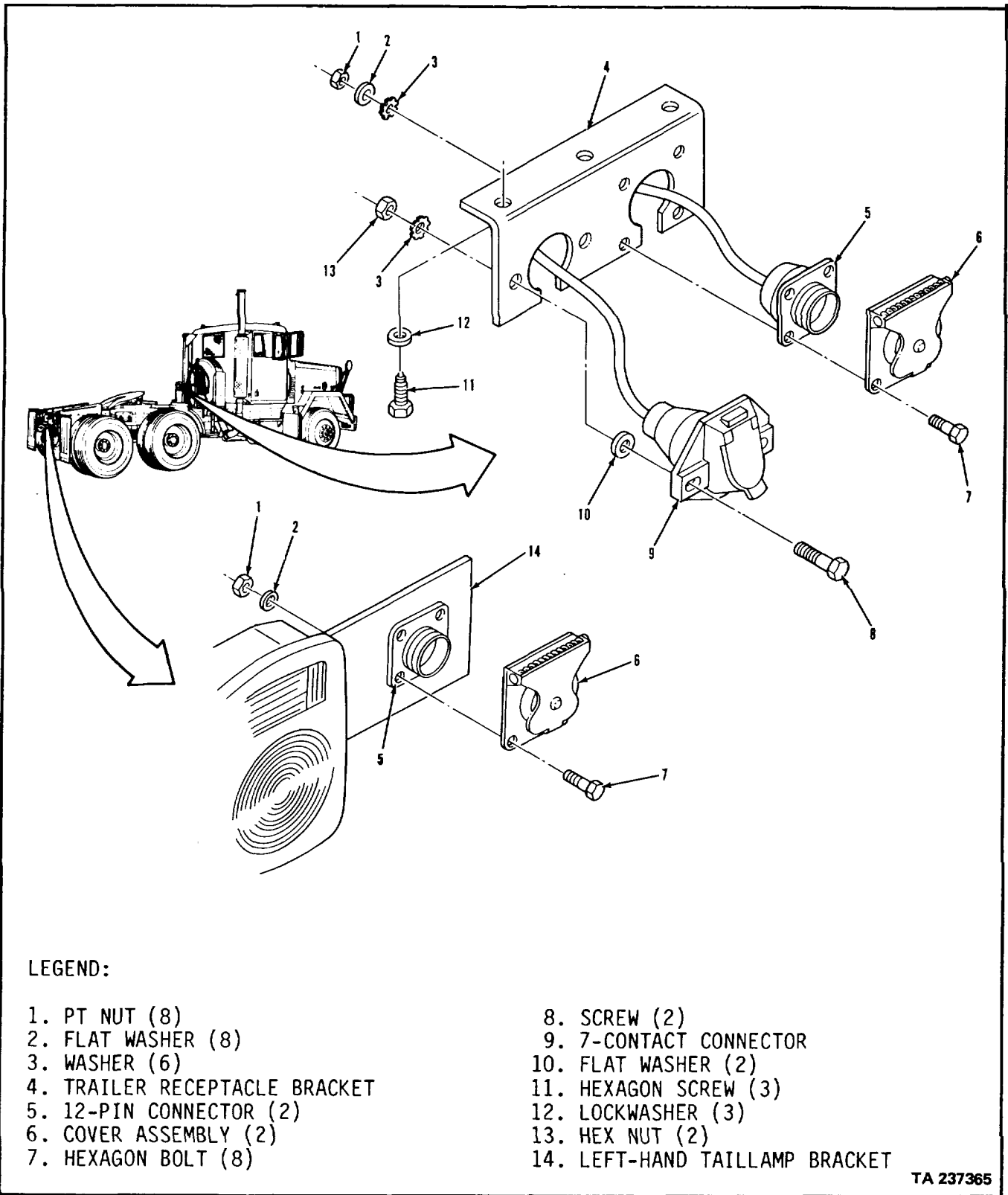

TA 237365

**ELECTRICAL SYSTEM.**

**3-131. STE/ICE CONNECTOR BRACKET REPLACEMENT.**

THIS TASK COVERS

- a. Removal.
- b. Installation.

INITIAL SETUP

<p><u>APPLICABLE CONFIGURATIONS</u> All.</p>	<p><u>EQUIPMENT CONDITION PARAGRAPH</u> 3-38.</p>	<p><u>CONDITION DESCRIPTION</u> Ether cylinder removed.</p>
<p><u>TEST EQUIPMENT</u> None.</p>		
<p><u>SPECIAL TOOLS</u> None.</p>		
<p><u>MATERIALS/PARTS (P/N)</u> None.</p>		
<p><u>PERSONNEL REQUIRED</u> One (MOS-63S).</p>	<p><u>SPECIAL ENVIRONMENTAL CONDITIONS</u> None.</p>	
<p><u>REFERENCES (TM)</u> None.</p>	<p><u>GENERAL SAFETY INSTRUCTIONS</u> Engine off. Transmission in neutral. Park brake set.</p>	
<p><u>TROUBLESHOOTING REFERENCES</u> Paragraph 2-11.</p>		



ELECTRICAL SYSTEM.

3-131. STE/ICE CONNECTOR BRACKET REPLACEMENT (Continued).

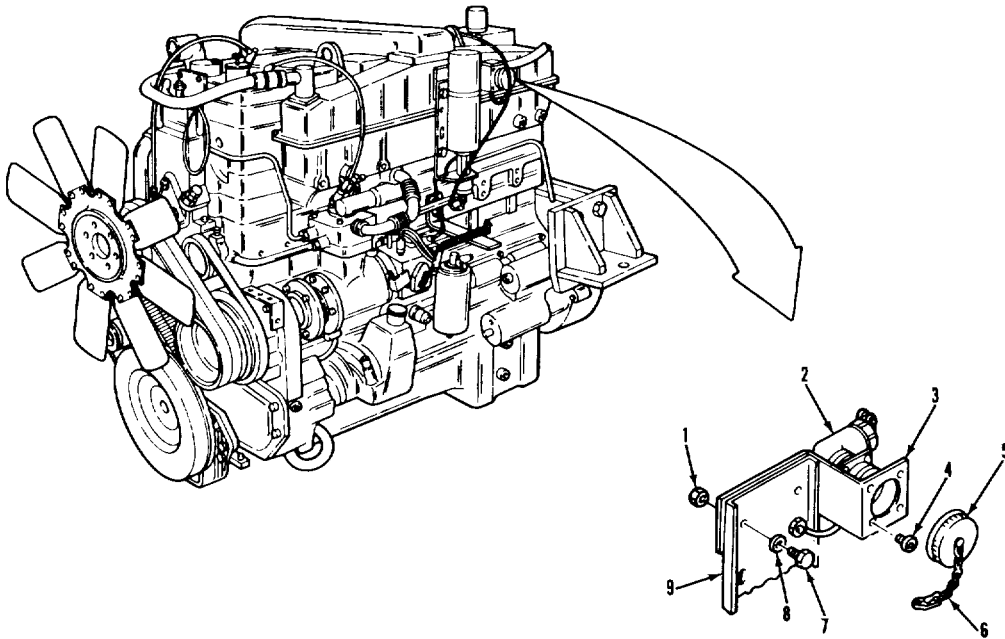

LEGEND:

- |                              |                          |
|------------------------------|--------------------------|
| 1. NUT (2)                   | 6. CAP CHAIN             |
| 2. STE/ICE CONNECTOR         | 7. SCREW (2)             |
| 3. STE/ICE CONNECTOR BRACKET | 8. WASHER (2)            |
| 4. CAPSCREW (4)              | 9. ETHER QUICK START KIT |
| 5. STE/ICE CONNECTOR CAP     |                          |

TA 237366

**ELECTRICAL SYSTEM.****3-131. STE/ICE CONNECTOR BRACKET REPLACEMENT (Continued).**

LOCATION / ITEM	ACTION	REMARKS
A. <u>REMOVAL.</u>		
1. Cap (5).	Remove from item (2).	
2. Four capscrews (4).	Remove from item (6), item (3), and item (2).	
3. Connector (2).	Remove from item (3).	
4. Two screws (7), washers (8), and nuts (1).	Remove from item (9) and item (3).	
5. Bracket (3).	Remove.	
B. <u>INSTALLATION.</u>		
6. Bracket (3).	Put in place on item (9).	
7. Two screws (7), washers (8), and nuts (1).	Secure item (3) to item (9).	
8. Connector (2).	Put in place in item (3).	
9. Four capscrews (4).	Secure item (6) and item (2) to item (3).	
10. Cap (5).	Install on item (2).	

**NOTE**

**Follow-on maintenance action required:  
Install ether cylinder (para 3-38).**

ELECTRICAL SYSTEM.

3-131. STE/ICE CONNECTOR BRACKET REPLACEMENT (Continued).

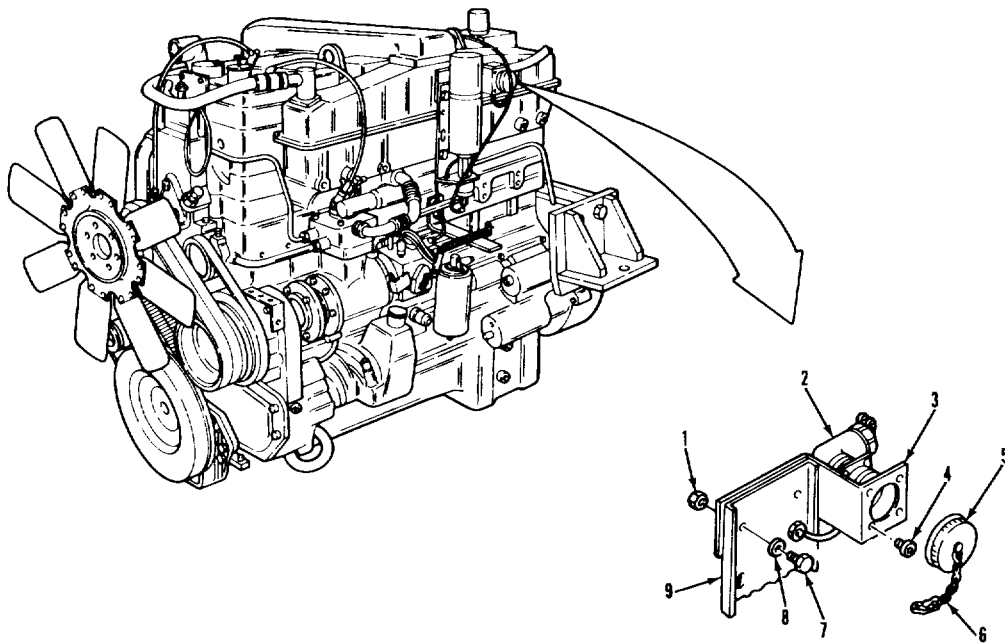

LEGEND:

- |                              |                          |
|------------------------------|--------------------------|
| 1. NUT (2)                   | 6. CAP CHAIN             |
| 2. STE/ICE CONNECTOR         | 7. SCREW (2)             |
| 3. STE/ICE CONNECTOR BRACKET | 8. WASHER (2)            |
| 4. CAPSCREW (4)              | 9. ETHER QUICK START KIT |
| 5. STE/ICE CONNECTOR CAP     |                          |

TA 237367

**ELECTRICAL SYSTEM.**

**3-132. UTILITY OUTLET RECEPTACLE REPLACEMENT.**

THIS TASK COVERS

- a. Removal.
- b. Installation.

INITIAL SETUP

<p><u>APPLICABLE CONFIGURATIONS</u> All.</p>	<p><u>EQUIPMENT CONDITION PARAGRAPH</u> None.</p>	<p><u>CONDITION DESCRIPTION</u> None.</p>
<p><u>TEST EQUIPMENT</u> None.</p>		
<p><u>SPECIAL TOOLS</u> None.</p>		
<p><u>MATERIALS/PARTS (P/N)</u> Rivet (2) (11815) SSPQ-41.</p>		
<p><u>PERSONNEL REQUIRED</u> One (MOS-63S).</p>	<p><u>SPECIAL ENVIRONMENTAL CONDITIONS</u> None.</p>	
<p><u>REFERENCES (TM)</u> TM 9-2320-283-20P.</p>	<p><u>GENERAL SAFETY INSTRUCTIONS</u> Engine off. Park brake set. Transmission in neutral.</p>	
<p><u>TROUBLESHOOTING REFERENCES</u> Paragraph 2-11.</p>		

ELECTRICAL SYSTEM.

3-132. UTILITY OUTLET RECEPTACLE REPLACEMENT (Continued).

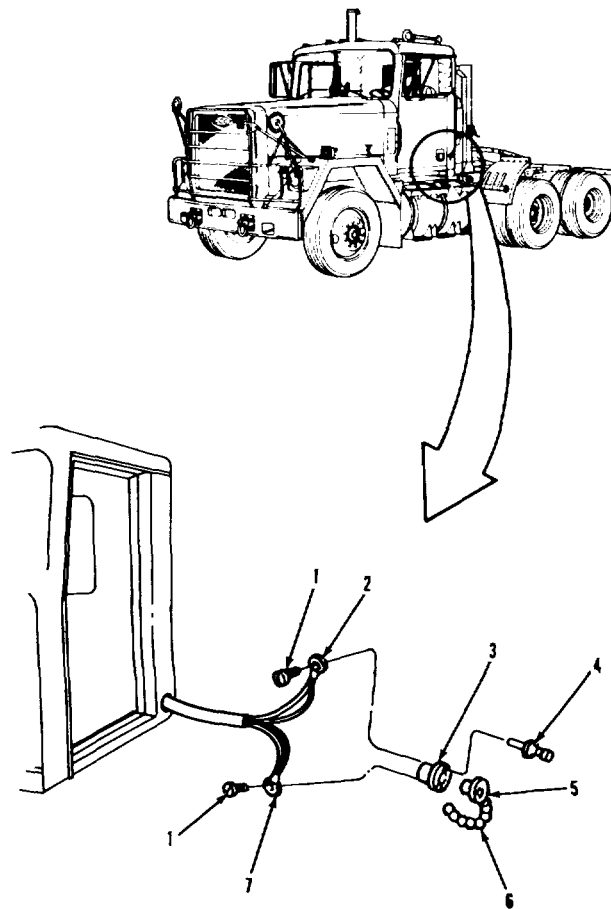

LEGEND:

- 1. SCREW (2)
- 2. RING TERMINAL  
(21A AND 21B-LEFT SIDE)  
(21B-RIGHT SIDE)
- 3. FLANGED INLET
- 4. RIVET (2)

- 5. FLANGED INLET COVER
- 6. COVER CHAIN
- 7. RING TERMINAL  
(99C AND 99D-LEFT SIDE)  
(99D-RIGHT SIDE)

TA 237368

**ELECTRICAL SYSTEM.**

**3-132. UTILITY OUTLET RECEPTACLE REPLACEMENT (Continued).**

LOCATION / ITEM	ACTION	REMARKS
<b>NOTE</b>		
<b>Replacement of utility outlet receptacles is the same for both sides.</b>		
A. <u>REMOVAL.</u>		
1. Two rivets (4). item (6).	Remove from item (3) and	Use a drill and drill motor.
2. Cover (5).	Remove from item (3).	
3. Inlet (3).	Pull away from cab.	
4. Two screws (1), terminal (2), and terminal (7).	Remove from item (3).	
B. <u>INSTALLATION.</u>		
5. Terminal (2), terminal (7), and two screws (1).	Install on item (3).	Terminal (2) should go to gold colored contact.
6. Coyer (5).	Install in item (3).	
7. Inlet (3).	Put in place in cab.	
8. Two new rivets (4).	Secure item (3) and item (6) to cab.	

**NOTE**

**Follow-on maintenance action required:**  
None.

ELECTRICAL SYSTEM.

3-132. UTILITY OUTLET RECEPTACLE REPLACEMENT (Continued).

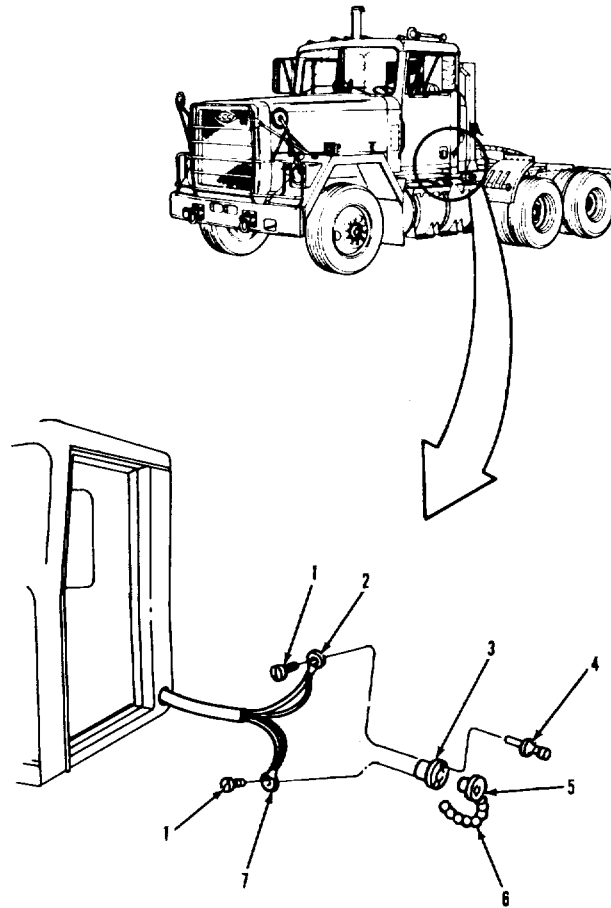

LEGEND:

- |   |   |
|---|---|
| 1. SCREW (2)  | 5. FLANGED INLET COVER  |
| 2. RING TERMINAL<br>(21A AND 21B-LEFT SIDE)<br>(21B-RIGHT SIDE) | 6. COVER CHAIN  |
| 3. FLANGED INLET  | 7. RING TERMINAL<br>(99C AND 99D-LEFT SIDE)<br>(99D-RIGHT SIDE) |
| 4. RIVET (2)  |   |

TA 237369

**Section VII. TRANSMISSION**

3-133. GENERAL.

This section provides procedures authorized at the organizational maintenance level to replace transmission components. To find a specific procedure contained in this section, see the task summary below.

3-134. TASK SUMMARY.

INITIAL SETUP

APPLICABLE CONFIGURATIONS

All.

TEST EQUIPMENT

None.

SPECIAL TOOLS

None.

MATERIALS/PARTS (P/N)

Tape, thread sealing  
Item 32, Appendix C.  
Fluid, transmission  
Refer to LO 9-2320-283-12.  
Filter, oil  
(70040) 25010643.  
O-ring (2)  
(24617) 274251.  
Gasket, oil pan  
(73342) 23010642.

EQUIPMENT CONDITION  
PARAGRAPH

(Refer to specific paragraph for this information).

CONDITION DESCRIPTION

Filter, oil (73342) 6884473.	O-ring (85757) 2117.
Seal, ring (73342) 23013114.	Pin, cotter (85757) 10087-2.
Pin, cotter (24617) 9427317.	Tie, cable (2) (06383) PLT4H-LO.
Pin, cotter (85757) 10166.	O-ring (as required) (24617) 274251.

PERSONNEL REQUIRED

Two (MOS-63S).

SPECIAL ENVIRONMENTAL CONDITIONS

Work area clean and away from blowing dirt and dust.

REFERENCES (TM)

LO 9-2320-283-12.  
TM 9-2320-283-10.  
TM 9-2320-238-20P.

GENERAL SAFETY INSTRUCTIONS

Engine off.  
Transmission in neutral.  
Park brake set.  
Use care when draining hot transmission oil.

TROUBLESHOOTING REFERENCES

Paragraph 2-11.



## TRANSMISSION.

<b>3-134. TASK SUMMARY (Continued).</b>			
LIST OF TASKS			
TASK NO.	TASK	TASK REF	TROUBLESHOOTING REF NO. (PARA)
1	Transmission Servicing	3-135	2-11
	a. Draining	3-135a	
	b. Breather Replacement	3-135b	
	c. External Oil Filter Replacement	3-135c	
	d. Internal Oil Filter Replacement	3-135d	
	e. Filling	3-135e	
2	Oil Level Gage and Tube Replacement	3-136	
	a. Removal	3-136a	
	b. Cleaning and Inspection	3-136b	
	c. Installation	3-136c	
3	Shifter Control Replacement	3-137	2-11
	a. Removal	3-137a	
	b. Cleaning and Inspection	3-137b	
	c. Installation	3-137c	
4	Shifter Control Cable Replacement	3-138	2-11
	a. Removal	3-138a	
	b. Cleaning and Inspection	3-138b	
	c. Installation	3-138c	
	d. Adjustment	3-138d	
5	Shifter Control Mounting Bracket Replacement	3-139	
	a. Removal	3-139a	
	b. Cleaning and Inspection	3-139b	
	c. Installation	3-139c	
6	Modulator Control Replacement	3-140	2-11
	a. Removal	3-140a	
	b. Cleaning and Inspection	3-140b	
	c. Installation	3-140c	
	d. Adjustment	3-140d	
7	Lines and Fittings Replacement	3-141	
	a. External Oil Filter Lines and Fittings Replacement.	3-141a	
	b. Oil Cooler Lines and Fittings Replacement.	3-141b	

**TRANSMISSION.**

3-135. TRANSMISSION SERVICING.																																																														
LOCATION/ITEM	ACTION	REMARKS																																																												
<p><u>THIS TASK COVERS</u></p> <p>a. Draining. <span style="float: right;">d. Internal Oil Filter Replacement.</span>                      b. Breather Replacement. <span style="float: right;">e. Filling.</span>                      c. External Oil Filter Replacement.</p>																																																														
<p>INITIAL SETUP</p> <table border="0" style="width: 100%;"> <tr> <td style="width: 33%;"><u>APPLICABLE CONFIGURATIONS</u></td> <td style="width: 33%;"><u>EQUIPMENT CONDITION</u></td> <td style="width: 33%;"><u>CONDITION DESCRIPTION</u></td> </tr> <tr> <td>All.</td> <td>None.</td> <td>None.</td> </tr> <tr> <td><u>TEST EQUIPMENT</u></td> <td></td> <td></td> </tr> <tr> <td>None.</td> <td></td> <td></td> </tr> <tr> <td><u>SPECIAL TOOLS</u></td> <td></td> <td></td> </tr> <tr> <td>None.</td> <td></td> <td></td> </tr> <tr> <td><u>MATERIALS/PARTS (P/N)</u></td> <td></td> <td></td> </tr> <tr> <td>Tape, thread sealing Item 32, Appendix C.</td> <td>Gasket, oil pan (73342) 23010652.</td> <td></td> </tr> <tr> <td>Fluid, transmission Refer to LO 9-2320-283-12.</td> <td>Filter, oil (73342) 6884473.</td> <td></td> </tr> <tr> <td>Filter, oil (70040) 25010643.</td> <td>Seal, ring (73342) 23013114.</td> <td></td> </tr> <tr> <td>O-ring (2) (24617) 274251.</td> <td></td> <td></td> </tr> <tr> <td><u>PERSONNEL REQUIRED</u></td> <td><u>SPECIAL ENVIRONMENTAL CONDITIONS</u></td> <td></td> </tr> <tr> <td>One (MOS-63S).</td> <td>Work area clean and away from blowing dirt and dust.</td> <td></td> </tr> <tr> <td><u>REFERENCES (TM)</u></td> <td><u>GENERAL SAFETY INSTRUCTIONS</u></td> <td></td> </tr> <tr> <td>LO 9-2320-283-12.</td> <td>Engine off.</td> <td></td> </tr> <tr> <td>TM 9-2320-283-10.</td> <td>Transmission in neutral.</td> <td></td> </tr> <tr> <td>TM 9-2320-283-20P.</td> <td>Park brake set.</td> <td></td> </tr> <tr> <td></td> <td>Use care when draining hot transmission oil.</td> <td></td> </tr> <tr> <td><u>TROUBLESHOOTING REFERENCES</u></td> <td></td> <td></td> </tr> <tr> <td>Paragraph 2-11.</td> <td></td> <td></td> </tr> </table>			<u>APPLICABLE CONFIGURATIONS</u>	<u>EQUIPMENT CONDITION</u>	<u>CONDITION DESCRIPTION</u>	All.	None.	None.	<u>TEST EQUIPMENT</u>			None.			<u>SPECIAL TOOLS</u>			None.			<u>MATERIALS/PARTS (P/N)</u>			Tape, thread sealing Item 32, Appendix C.	Gasket, oil pan (73342) 23010652.		Fluid, transmission Refer to LO 9-2320-283-12.	Filter, oil (73342) 6884473.		Filter, oil (70040) 25010643.	Seal, ring (73342) 23013114.		O-ring (2) (24617) 274251.			<u>PERSONNEL REQUIRED</u>	<u>SPECIAL ENVIRONMENTAL CONDITIONS</u>		One (MOS-63S).	Work area clean and away from blowing dirt and dust.		<u>REFERENCES (TM)</u>	<u>GENERAL SAFETY INSTRUCTIONS</u>		LO 9-2320-283-12.	Engine off.		TM 9-2320-283-10.	Transmission in neutral.		TM 9-2320-283-20P.	Park brake set.			Use care when draining hot transmission oil.		<u>TROUBLESHOOTING REFERENCES</u>			Paragraph 2-11.		
<u>APPLICABLE CONFIGURATIONS</u>	<u>EQUIPMENT CONDITION</u>	<u>CONDITION DESCRIPTION</u>																																																												
All.	None.	None.																																																												
<u>TEST EQUIPMENT</u>																																																														
None.																																																														
<u>SPECIAL TOOLS</u>																																																														
None.																																																														
<u>MATERIALS/PARTS (P/N)</u>																																																														
Tape, thread sealing Item 32, Appendix C.	Gasket, oil pan (73342) 23010652.																																																													
Fluid, transmission Refer to LO 9-2320-283-12.	Filter, oil (73342) 6884473.																																																													
Filter, oil (70040) 25010643.	Seal, ring (73342) 23013114.																																																													
O-ring (2) (24617) 274251.																																																														
<u>PERSONNEL REQUIRED</u>	<u>SPECIAL ENVIRONMENTAL CONDITIONS</u>																																																													
One (MOS-63S).	Work area clean and away from blowing dirt and dust.																																																													
<u>REFERENCES (TM)</u>	<u>GENERAL SAFETY INSTRUCTIONS</u>																																																													
LO 9-2320-283-12.	Engine off.																																																													
TM 9-2320-283-10.	Transmission in neutral.																																																													
TM 9-2320-283-20P.	Park brake set.																																																													
	Use care when draining hot transmission oil.																																																													
<u>TROUBLESHOOTING REFERENCES</u>																																																														
Paragraph 2-11.																																																														

| **3-794** | | |

TRANSMISSION.

3-135. TRANSMISSION SERVICING (Continued).

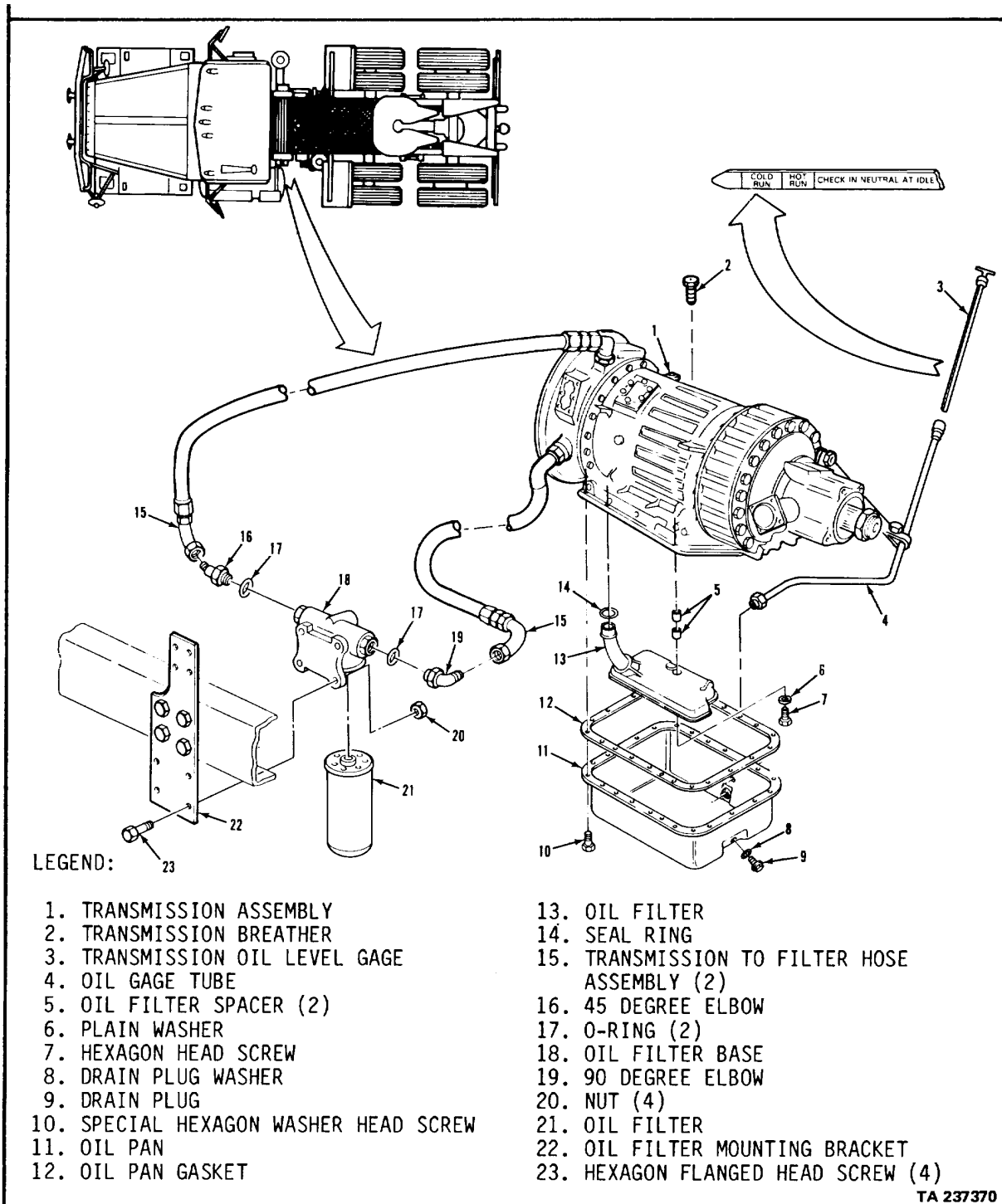

**TRANSMISSION.**

**3-135. TRANSMISSION SERVICING (Continued).**

LOCATION/ITEM	ACTION	REMARKS
<b><u>A. DRAINING.</u></b>		
<p><b><u>WARNING</u></b>                      Transmission fluid is hot. Use care when draining transmission fluid to prevent personal injury.</p>		
<p><b><u>NOTE</u></b>                      To ensure quicker and better drainage, transmission fluid should be at operating temperature (120°-200°F).</p>		
<p>1. Plug (9) and washer (8).</p>	<p>a. Place suitable container underneath.                      b. Remove from item (11) and let fluid drain out.                      c. Inspect fluid for metal particles and traces of coolant.                      d. Wrap threads with thread sealing tape and install into item (11).</p>	<p>If any metal particles or traces of coolant are found, discard fluid and notify DS/GS maintenance.                      Refer to paragraph 3-7.</p>
<b><u>B. BREATHER REPLACEMENT.</u></b>		
<p>2. Breather (2).</p>	<p>a. Remove from item (1).                      b. Clean and inspect.                      c. Install into item (1).</p>	<p>Refer to paragraphs 3-4 and 3-5.</p>
<p><b>3-796</b></p>		

TRANSMISSION.

3-135. TRANSMISSION SERVICING (Continued).

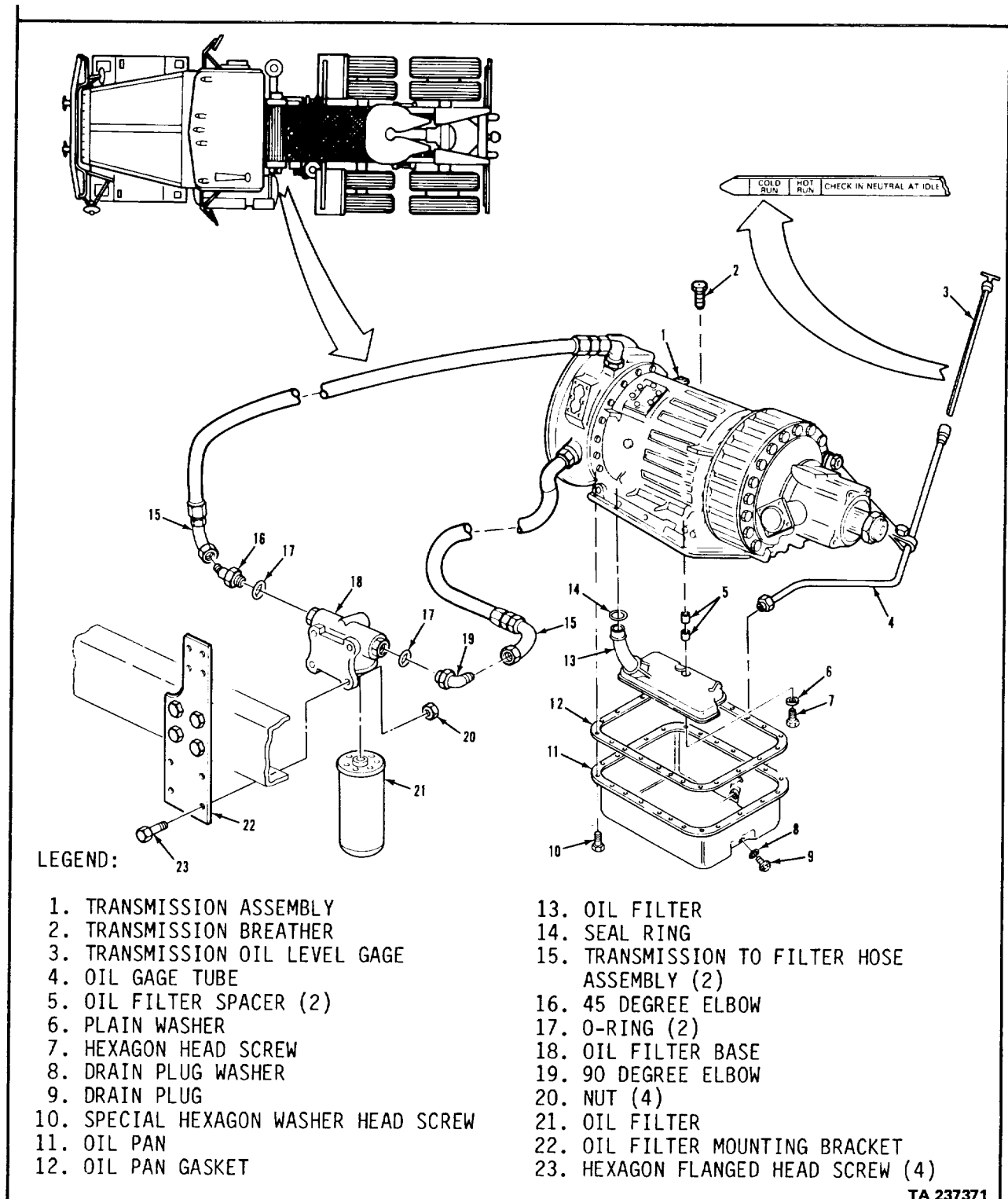

**TRANSMISSION.**

**3-135. TRANSMISSION SERVICING (Continued).**

LOCATION/ITEM	ACTION	REMARKS
<b><u>C. EXTERNAL OIL FILTER REPLACEMENT.</u></b>		
3. Filter (21).	a. Unscrew and remove from item (18). b. Pour contents into suitable container.	Have suitable container ready to catch any fluid. Discard item (21).
4. Two hoses (15).	Remove from items (16) and (19).	
5. Elbow (16), elbow	Remove from item (18), (19), and two O-rings (17).	Discard two items (17).
6. Four screws (23), nuts (20), and base (18).	Remove from item (22).	
7. All parts.	Clean and inspect.	Refer to paragraphs 3-4 and 3-5.
8. Base (18).	a. Position on item (22). b. Secure with four items (23) and (20).	
9. Elbow (16), elbow	a. Wrap threads of items (19), and two new O-rings (17). b. Coat two items (17) with clean lubricating oil. c. Install into item (18).	Refer to paragraph 3-7. (16) and (19) with thread sealing tape.
10. Two hoses (15).	Install onto items (16) and (19).	
11. New filter (21).	a. Lubricate sealing surface and fill with clean transmission fluid. b. Screw onto item (18) until contact is made, then tighten one more turn.	Do not overtighten item (21).
<b>3-798</b>		

TRANSMISSION.

3-135. TRANSMISSION SERVICING (Continued).

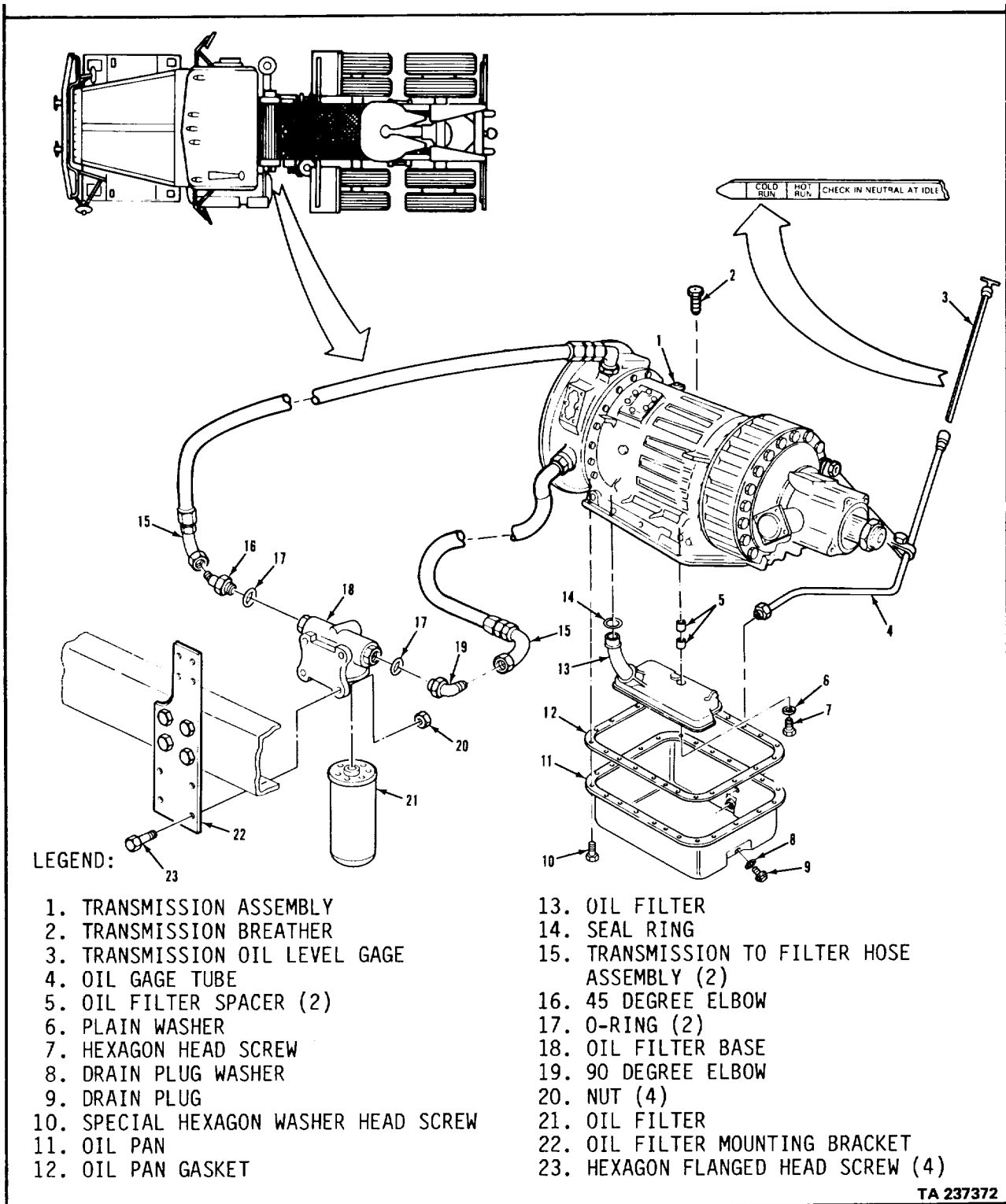

**TRANSMISSION.**

**3-135. TRANSMISSION SERVICING (Continued).**

LOCATION/ITEM	ACTION	REMARKS
<b><u>D. INTERNAL OIL FILTER REPLACEMENT.</u></b>		
12. Tube (4).	Unscrew and remove from item (11).	
13. Twenty-three screws (10).	Loosen one in each corner of item (11), and remove remaining nineteen.	Do not remove four corner items (10) at this time.
14. Pan (11) and gasket (12).	a. Tap with soft-faced hammer or mallet until loose. b. Hold while removing four corner items (10). c. Lower from item (1) and pour out any remaining fluid.	Discard item (12).
15. Screw (7), washer (6), and two spacers (5).	Remove from items (13) and (1)	
16. Filter (13) and ring (14).	Remove from item (1). (14).	Discard items (13) and (14).
17. All parts.	Clean and inspect.	Refer to paragraphs 3-4 and 3-5.
18. Pan (11).	Make sure sealing surface is flat and undamaged.	Flatten sealing surfaces or replace item (11) as needed.
19. New ring (14).	Install on new item (13).	Coat with clean lubricating oil.
20. Filter (13) and ring (14).	a. Push into place in item (1). b. Secure with items (7), (6), and two items (5).	Do not twist item (13) during installation; push it straight in. Torque item (7) to 10-13 lb-ft.



TRANSMISSION.

3-135. TRANSMISSION SERVICING (Continued).

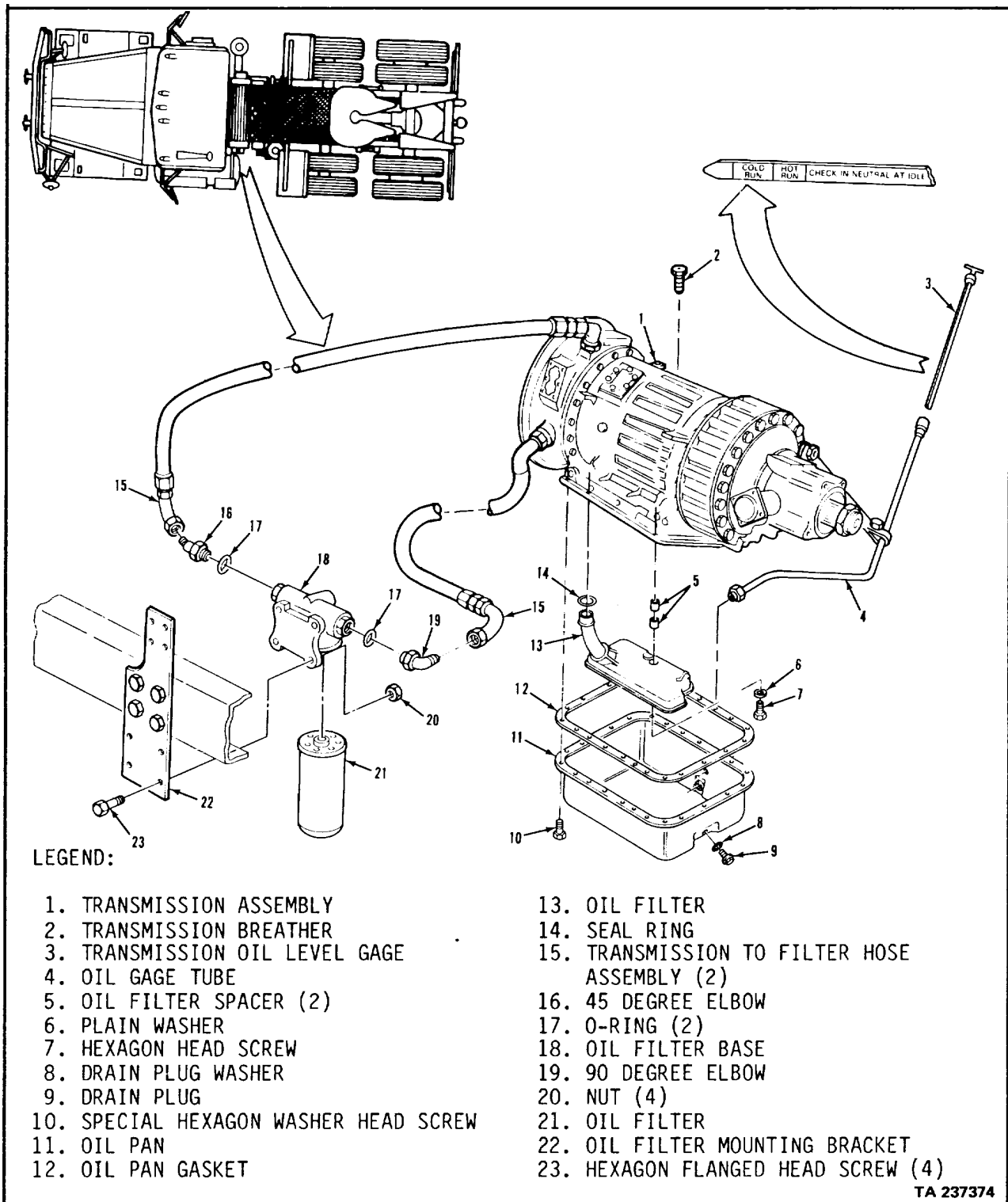

**TRANSMISSION.**

3-135. TRANSMISSION SERVICING (Continued).		
LOCATION/ITEM	ACTION	REMARKS
<b><u>D. INTERNAL OIL FILTER REPLACEMENT (Continued).</u></b>		
<b><u>CAUTION</u></b> Do not apply grease to a cork gasket. If necessary, a cement or sealer may be applied, but only in the area outside the raised bead on the oil pan flange.		
21. Pan (11) and new gasket (12).	a. Position under item (1).  b. Secure with twenty-three items (10).	Torque items (10) to 10-13 lb-ft.
22. Tube (4).	a. Wrap threads with thread sealing tape. b. Screw into item (11) and tighten.	Refer to paragraph 3-7.
<b><u>E. FILLING</u></b>		
23. Gage (3).	Unscrew handle until loose and pull out of item (4).	
24. Transmission (1).	Fill with transmission fluid through item (4).	Refer to LO 9-2320-283-12.
25. Gage (3).	Push into item (4) and screw in handle until tight.	
26. Engine and trans-	a. Start engine and shift mission. ranges to fill clutch cavities and passages. b. Shift transmission to neutral and let engine run for one minute at 1,000 rpm to clear air from system.	Refer to TM 9-2320-transmission through all 283-10.
<b>3-802</b>		

TRANSMISSION.

3-135. TRANSMISSION SERVICING (Continued).

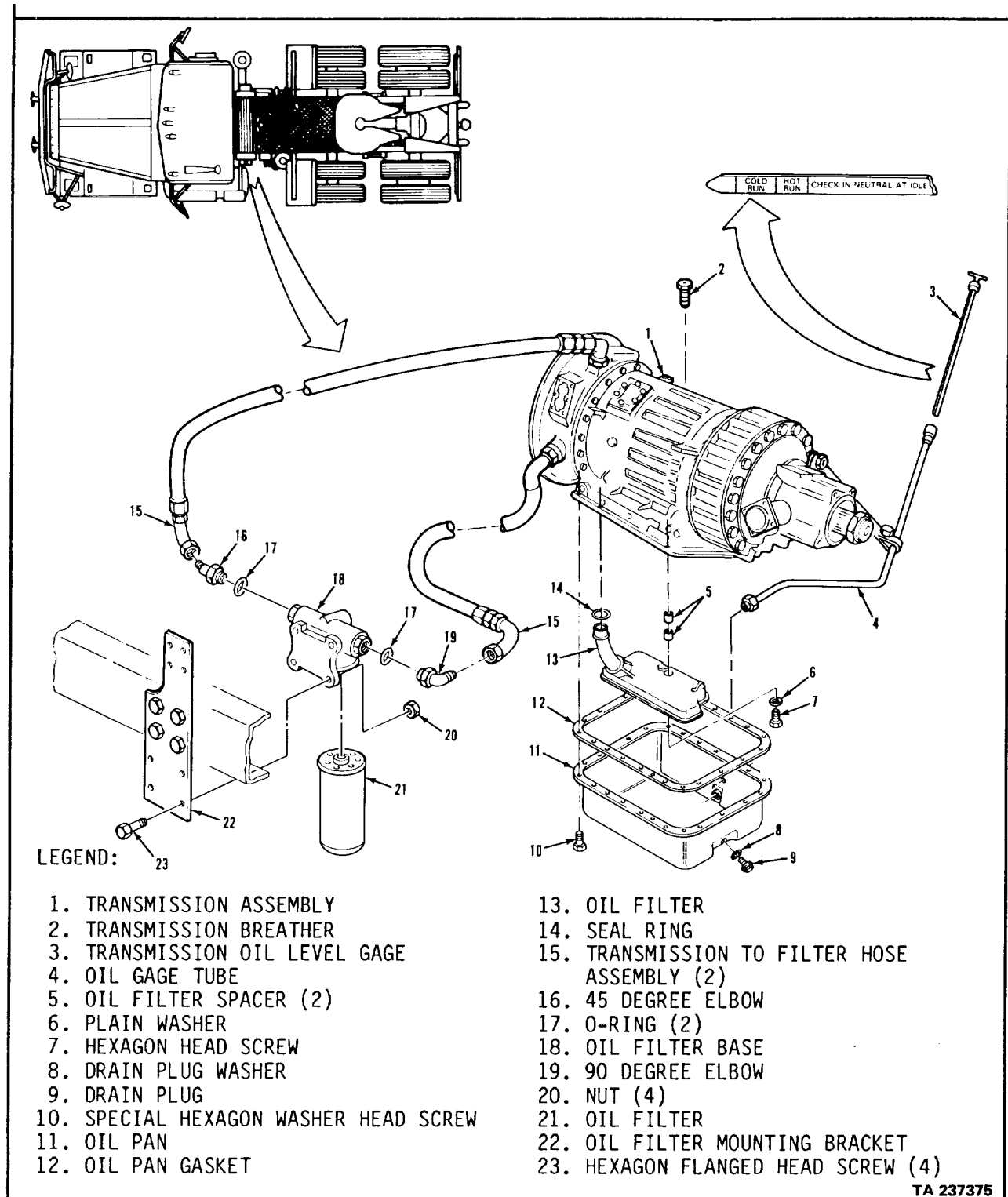

**TRANSMISSION.**

3-135. TRANSMISSION SERVICING (Continued).		
LOCATION/ITEM	ACTION	REMARKS
<b><u>E. FILLING (Continued).</u></b>		
27. Gage (3).	a. Unscrew handle until loose and pull out of item (4). b. Check transmission fluid level.  c. Push into item (4) and screw in handle until tight.	Fluid level should be within the COLD Run band (see illustration). Add or remove fluid as necessary until fluid level is level is correct. (Refer to LO 9-2320-283-12).
28. Engine.	Shut down.	Refer to TM 9-2320-283-10.
<b>NOTE</b> <b>Follow-on maintenance action required:</b> <b>None.</b>		
<b>3-804</b>		

TRANSMISSION.

3-135. TRANSMISSION SERVICING (Continued).

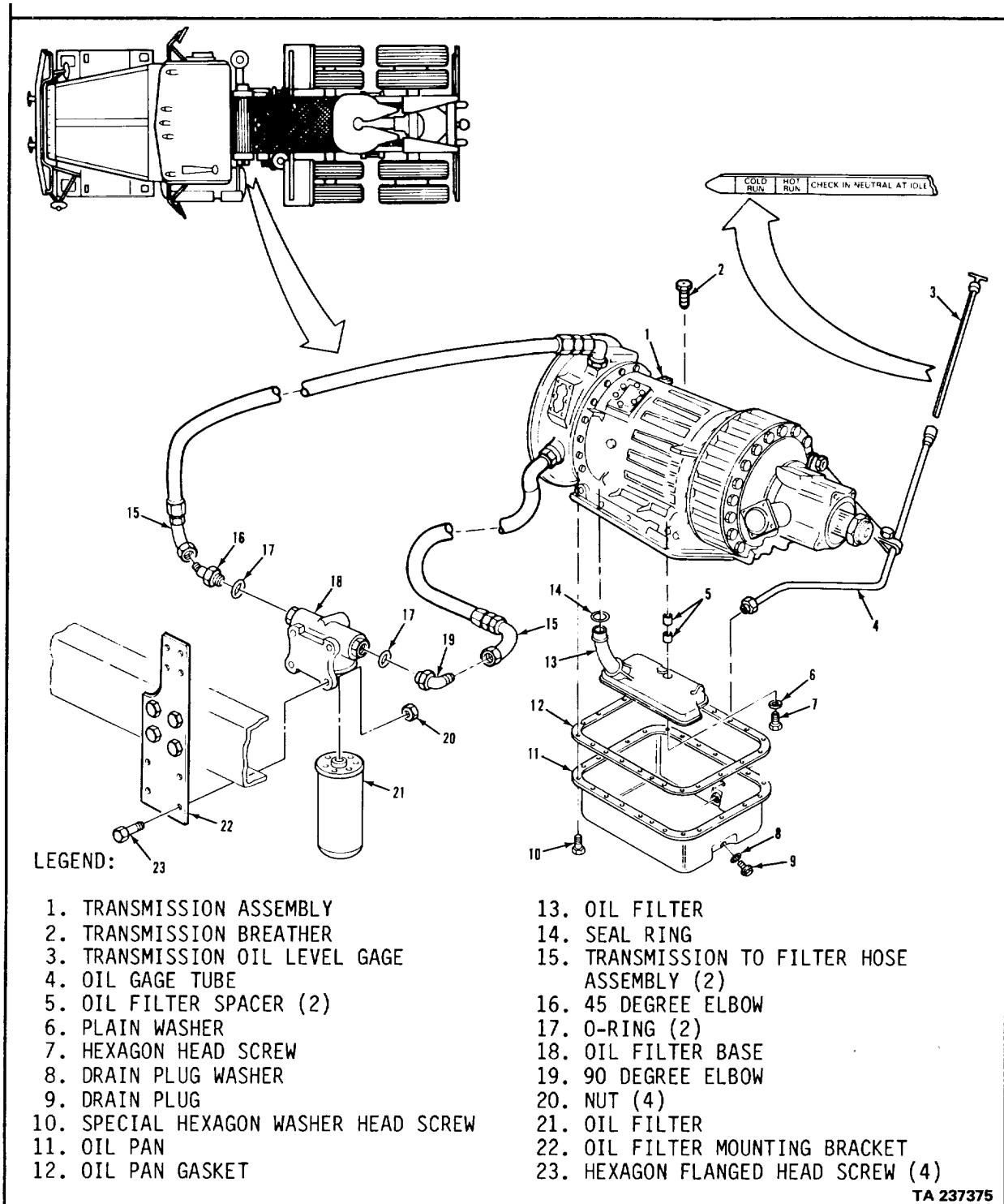

**TRANSMISSION.**

3-136. OIL LEVEL GAGE AND TUBE REPLACEMENT.		
LOCATION/ITEM	ACTION	REMARKS
<p><u>THIS TASK COVERS</u></p> <p>a. Removal.                      b. Cleaning and Inspection.                      c. Installation.</p>		
<p><u>INITIAL SETUP</u></p> <p><u>EQUIPMENT CONDITION</u>  <u>APPLICABLE CONFIGURATIONS</u>      <u>PARAGRAPH</u>      <u>CONDITION DESCRIPTION</u>                      All.      3-135.      Transmission drained.</p> <p><u>TEST EQUIPMENT</u>                      None.</p> <p><u>SPECIAL TOOLS</u>                      None.</p> <p><u>MATERIALS/PARTS (P/N)</u>                      Tape, thread sealing                      Item 24, Appendix C.</p> <p><u>PERSONNEL REQUIRED</u>      <u>SPECIAL ENVIRONMENTAL CONDITIONS</u>                      One (MOS-63S ).      None.</p> <p><u>REFERENCES (TM)</u>      <u>GENERAL SAFETY INSTRUCTIONS</u>                      None.      Engine off.                      Transmission in neutral.                      Park brake set.</p> <p><u>TROUBLESHOOTING REFERENCES</u>                      None.</p>		
<p><b>3-806</b></p>		

TRANSMISSION.

3-136. OIL LEVEL GAGE AND TUBE REPLACEMENT (Continued).

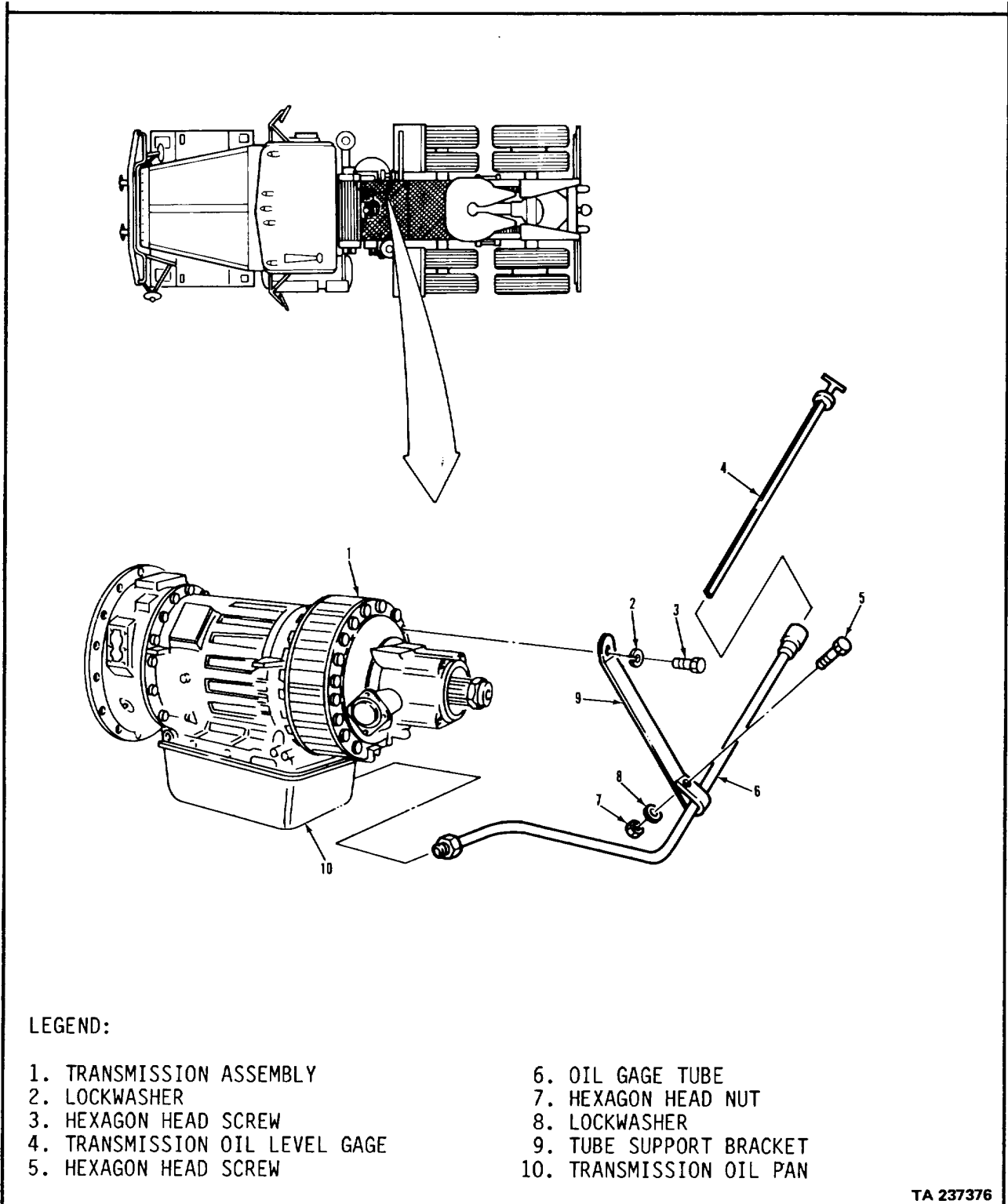

TA 237376

## TRANSMISSION.

3-136. OIL LEVEL GAGE AND TUBE REPLACEMENT (Continued).		
LOCATION/ITEM	ACTION	REMARKS
<b><u>A. REMOVAL.</u></b>		
1. Gage (4).	Unscrew handle until loose, and pull item (4) out of item (6).	
2. Screw (3) and lockwasher (2).	Remove from items (9) and (1).	
3. Tube (6).	Unscrew and remove from item (10).	
4. Nut (7), lockwasher (8), and screw (5).	Remove from item (9).	
5. Bracket (9).	Remove from item (6).	
<b><u>B. CLEANING AND INSPECTION.</u></b>		
6. All parts.	Clean and inspect.	Refer to paragraphs 3-4 and 3-5.
<b><u>C. INSTALLATION.</u></b>		
7. Bracket (9).	Install on item (6).	
8. Screw (5), lockwasher (8), and nut (7).	Install into item (9), but do not tighten.	
9. Tube (6).	a. Wrap threads with thread sealing tape. b. Screw into item (10) and tighten.	Refer to paragraph 3-7.
<b>3-808</b>		



TRANSMISSION.

3-136. OIL LEVEL GAGE AND TUBE REPLACEMENT (Continued).

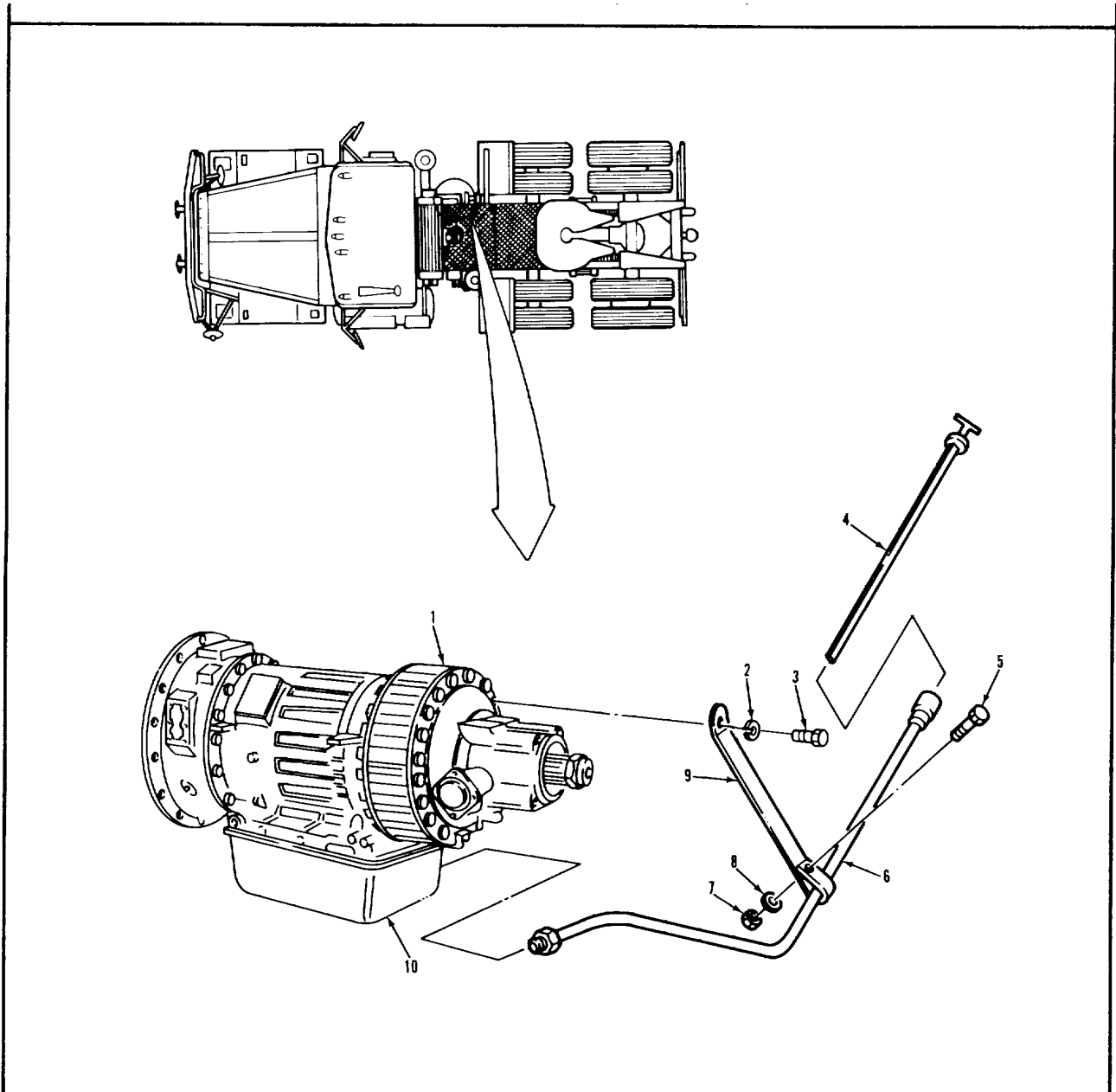

LEGEND:

- |                                |                          |
|--------------------------------|--------------------------|
| 1. TRANSMISSION ASSEMBLY       | 6. OIL GAGE TUBE         |
| 2. LOCKWASHER                  | 7. HEXAGON HEAD NUT      |
| 3. HEXAGON HEAD SCREW          | 8. LOCKWASHER            |
| 4. TRANSMISSION OIL LEVEL GAGE | 9. TUBE SUPPORT BRACKET  |
| 5. HEXAGON HEAD SCREW          | 10. TRANSMISSION OIL PAN |

TA 237377

TRANSMISSION.

3-136. OIL LEVEL GAGE AND TUBE REPLACEMENT (Continued).		
LOCATION/ITEM	ACTION	REMARKS
<b><u>C. INSTALLATION (Continued).</u></b>		
10. Bracket (9).	a. Position on item (1). b. Secure with items (3) and (2). Tighten.	Torque to 67-80 lb-ft.
11. Screw (5) and nut (7).	Fill.	Refer to paragraph 3-135.
12. Transmission.	Push into item (6) and screw in handle until tight.	
13. Gage (4).		
<p><b>NOTE</b>  <b>Follow-on maintenance action required:</b>  <b>None.</b></p>		
<p><b>3-810</b></p>		

TRANSMISSION.

3-136. OIL LEVEL GAGE AND TUBE REPLACEMENT (Continued).

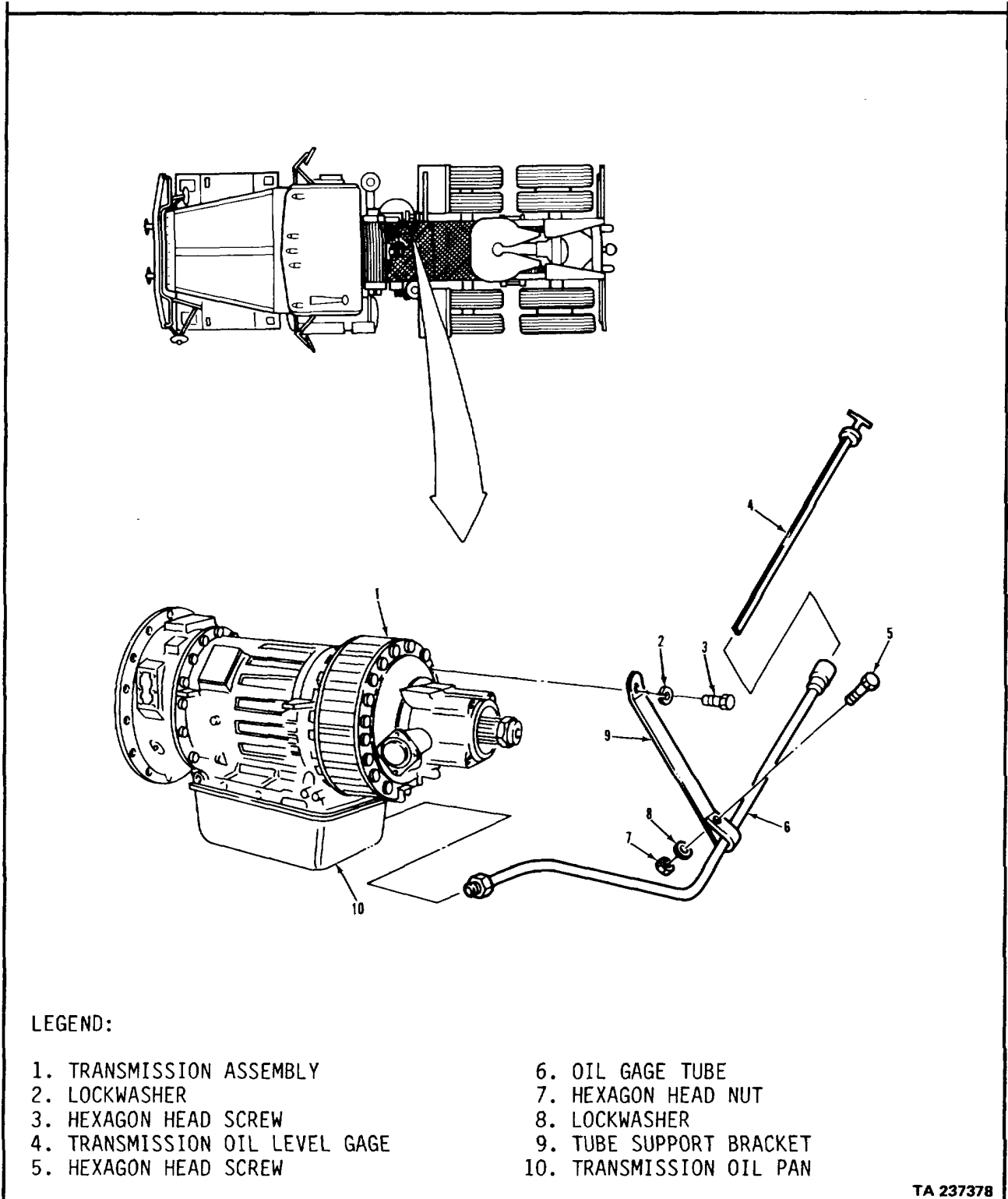

TA 237378

**TRANSMISSION.**

**3-137. SHIFTER CONTROL REPLACEMENT.**

LOCATION/ITEM	ACTION	REMARKS
<p>THIS TASK COVERS</p> <ul style="list-style-type: none"> <li>a. Removal.</li> <li>b. Cleaning and Inspection.</li> <li>c. Installation.</li> </ul>		
<p><u>INITIAL SETUP</u></p>		
<p><u>APPLICABLE CONFIGURATIONS</u> All.</p>	<p><u>EQUIPMENT CONDITION</u> <u>PARAGRAPH</u> None.</p>	<p><u>CONDITION DESCRIPTION</u> None.</p>
<p><u>TEST EQUIPMENT</u> None.</p>		
<p><u>SPECIAL TOOLS</u> None.</p>		
<p><u>MATERIALS/PARTS (P/N)</u> None.</p>		
<p><u>PERSONNEL REQUIRED</u> One (MOS-63S).</p>	<p><u>SPECIAL ENVIRONMENTAL CONDITIONS</u> None.</p>	
<p><u>REFERENCES (TM)</u> None.</p>	<p><u>GENERAL SAFETY INSTRUCTIONS</u> Engine off. Transmission in neutral. Park brake set.</p>	
<p><u>TROUBLESHOOTING REFERENCES</u> Paragraph 2-11.</p>		
<p><b>3-812</b></p>		

TRANSMISSION.

3-137. SHIFTER CONTROL REPLACEMENT (Continued).

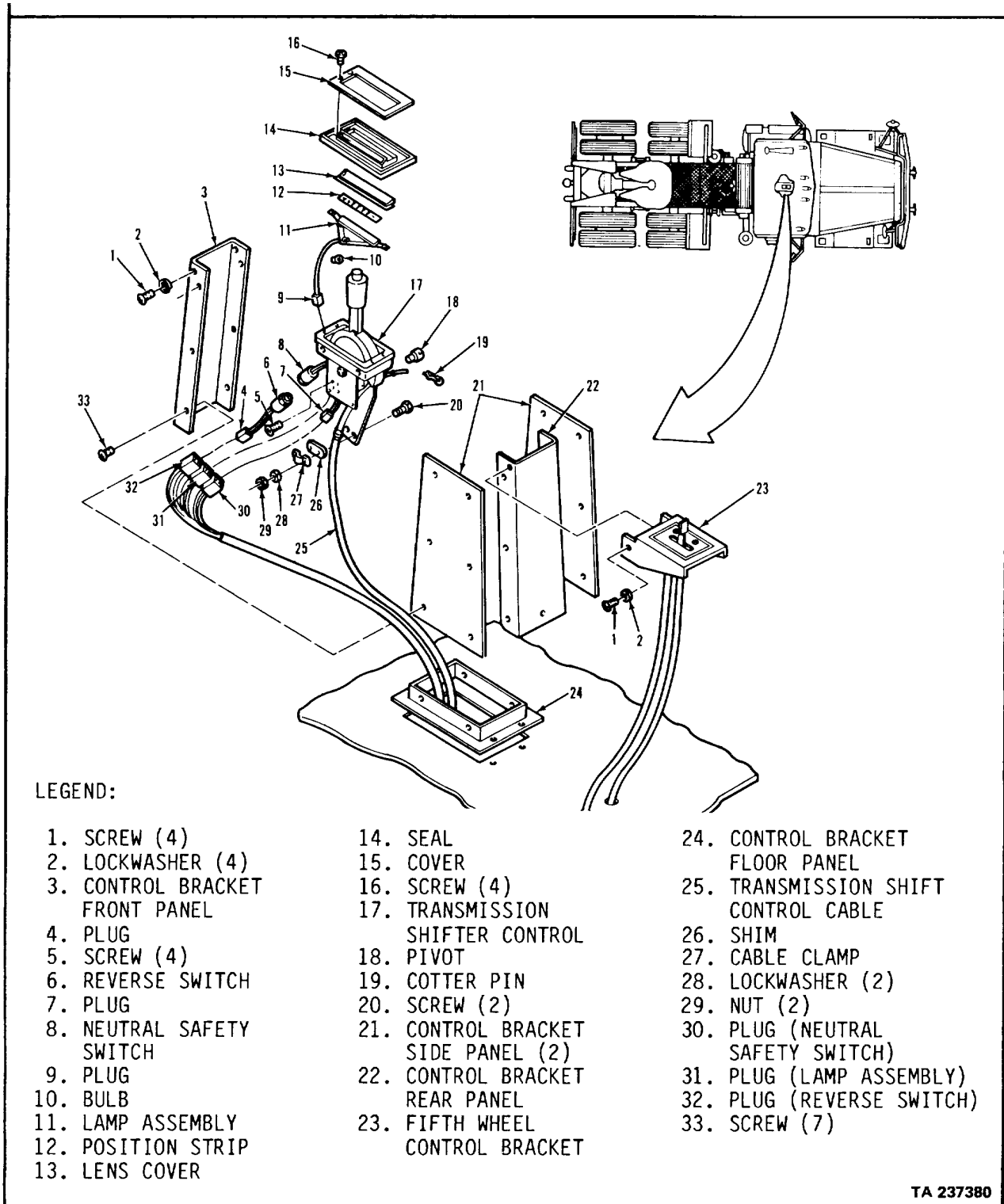

TA 237380

**TRANSMISSION.**

<b>3-137. SHIFTER CONTROL REPLACEMENT (Continued).</b>		
<b>LOCATION/ITEM</b>	<b>ACTION</b>	<b>REMARKS</b>
<b><u>A. REMOVAL.</u></b>		
1. Two screws (1) and lock-washers (2).	Remove from items (23), (22), and (17).	
2. Bracket (23).	Remove from item (22) and set aside.	Do not disconnect air lines.
3. Two other screws (1) and lock-washers (2).	Remove from items (3) and (17).	
4. Seven screws (33) and panel (3).	Remove from items (21) and (24).	
5. Control (17). (21) and (22).	a. Lift up and out of items	
6. Three plugs (4), (7), and (9).	b. Shift into FIRST GEAR (1). Disconnect from items (30), (31), and (32).	Be sure to tag items (30), (31), and (32) before disconnecting.
7. Two nuts (29), lockwashers (28), screws (18), clamp (27), and shim (26).	Remove from items (17) and (25).	
8. Pin (19).	Remove from item (18).	
9. Pivot (18) and cable (25).	Remove from item (17).	
10. Four screws (16), cover (15), seal (14), lens (13), strip (12), and assembly (11).	Remove from item (17).	

TRANSMISSION.

3-137. SHIFTER CONTROL REPLACEMENT (Continued).

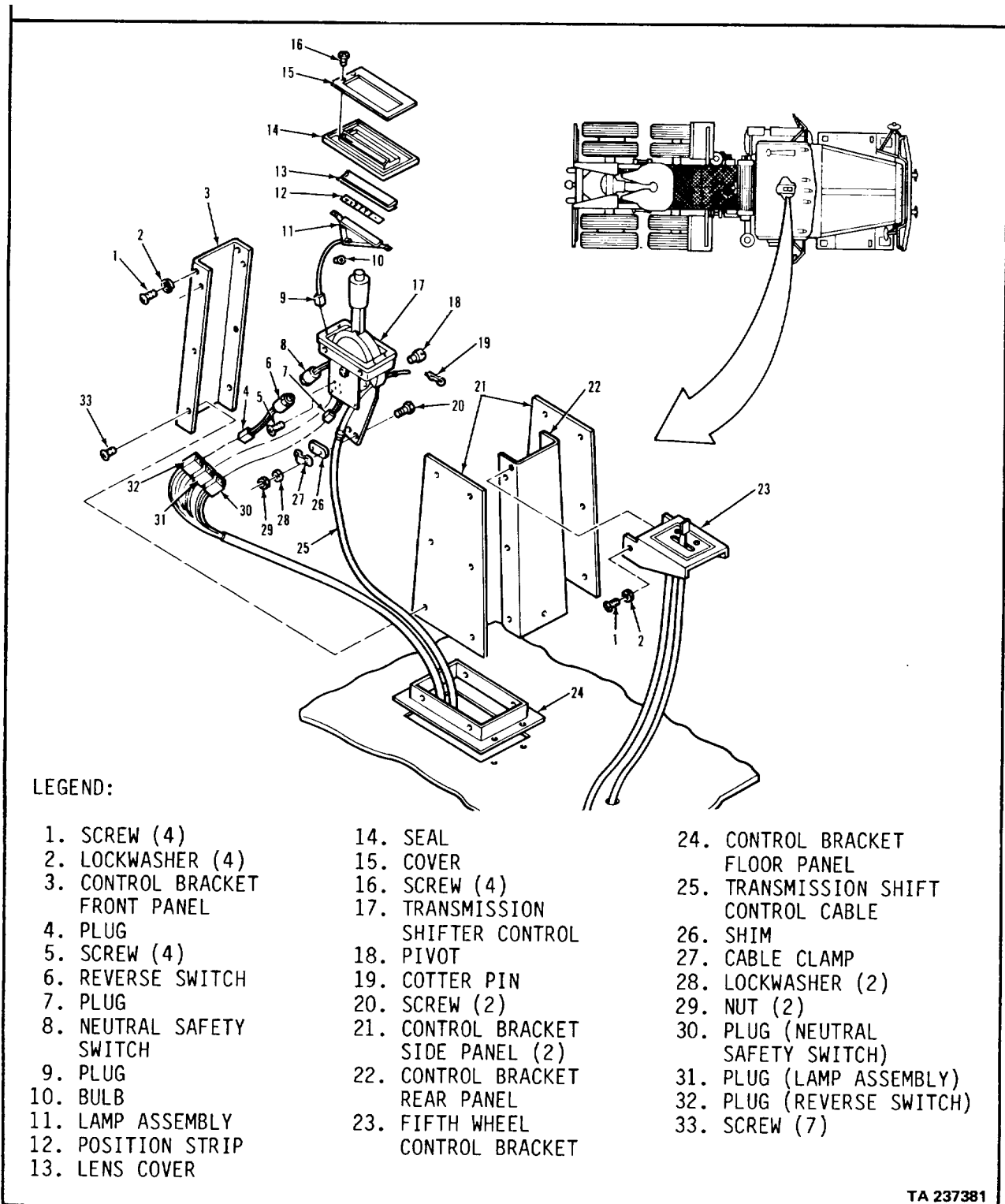

TA 237381

**TRANSMISSION.**

<b>3-137. SHIFTER CONTROL REPLACEMENT (Continued).</b>		
<b>LOCATION/ITEM</b>	<b>ACTION</b>	<b>REMARKS</b>
<b><u>A. REMOVAL (Continued).</u></b>		
11. Bulb (10).	Remove from item (11).	
12. Four screws (5) and two switches (6) and (8).	Remove from item (17).	
<b><u>B. CLEANING AND INSPECTION.</u></b>		
13. All parts. and 3-5.	Clean and inspect.	Refer to paragraphs 3-4
<b><u>C. INSTALLATION.</u></b>		
14. Two switches (6) and (8) and four screws (5).	Install on item (17).	
15. Bulb (10).	Install into item (11).	
16. Assembly (11), strip (12), lens (13), seal (14), and cover (15).	a. Position on item (17). (11) goes down through item (17).  b. Secure with four items (16).	Make sure wire of item
17. Control (17).	Shift into FIRST GEAR (1).	
18. Pivot (18) and cable (25).	a. Position on item (17).  b. Secure item (18) to item (17) with item (19). c. Secure item (25) to item (17) with items (26), (27), and two items (20), (28), and (29).	Be sure to secure metal part of item (25) to item (17).
<b>3-816</b>		



TRANSMISSION.

3-137. SHIFTER CONTROL REPLACEMENT (Continued).

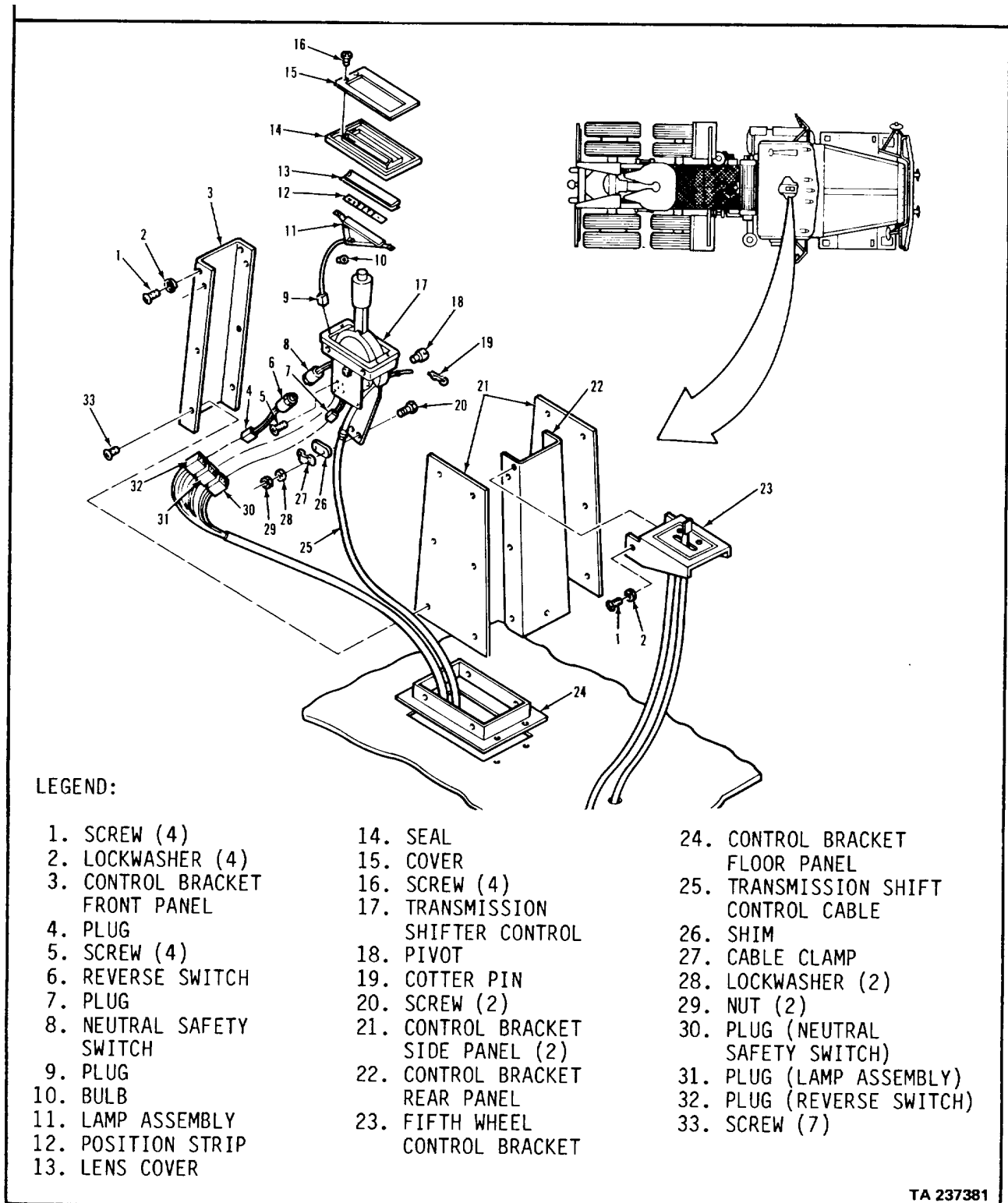

TA 237381

**TRANSMISSION.**

<b>3-137. SHIFTER CONTROL REPLACEMENT (Continued).</b>		
<b>LOCATION/ITEM</b>	<b>ACTION</b>	<b>REMARKS</b>
<b><u>C. INSTALLATION (Continued).</u></b>		
19. Three plugs (4), (7), and (9).	Connect to (30), (31), and (32).	Remove tags.
20. Control (17).	Lift up and set on top of items (21) and (22).	
21. Panel (3).	a. Position on items (21) and (24). b. Secure with seven items (33).	
22. Two screws (1) and lockwashers (2).	Install into items (3) and (17), but do not tighten.	
23. Bracket (23).	a. Position on item (22). b. Secure with two items (1) and (2).	Other two items (1) and (2) can be tightened at this time.
<p><b>NOTE</b>  <b>Follow-on maintenance action required:</b>  <b>Adjust shifter control cable</b>  <b>(para 3-138).</b></p>		
<p><b>3-818</b></p>		

TRANSMISSION.

3-137. SHIFTER CONTROL REPLACEMENT (Continued).

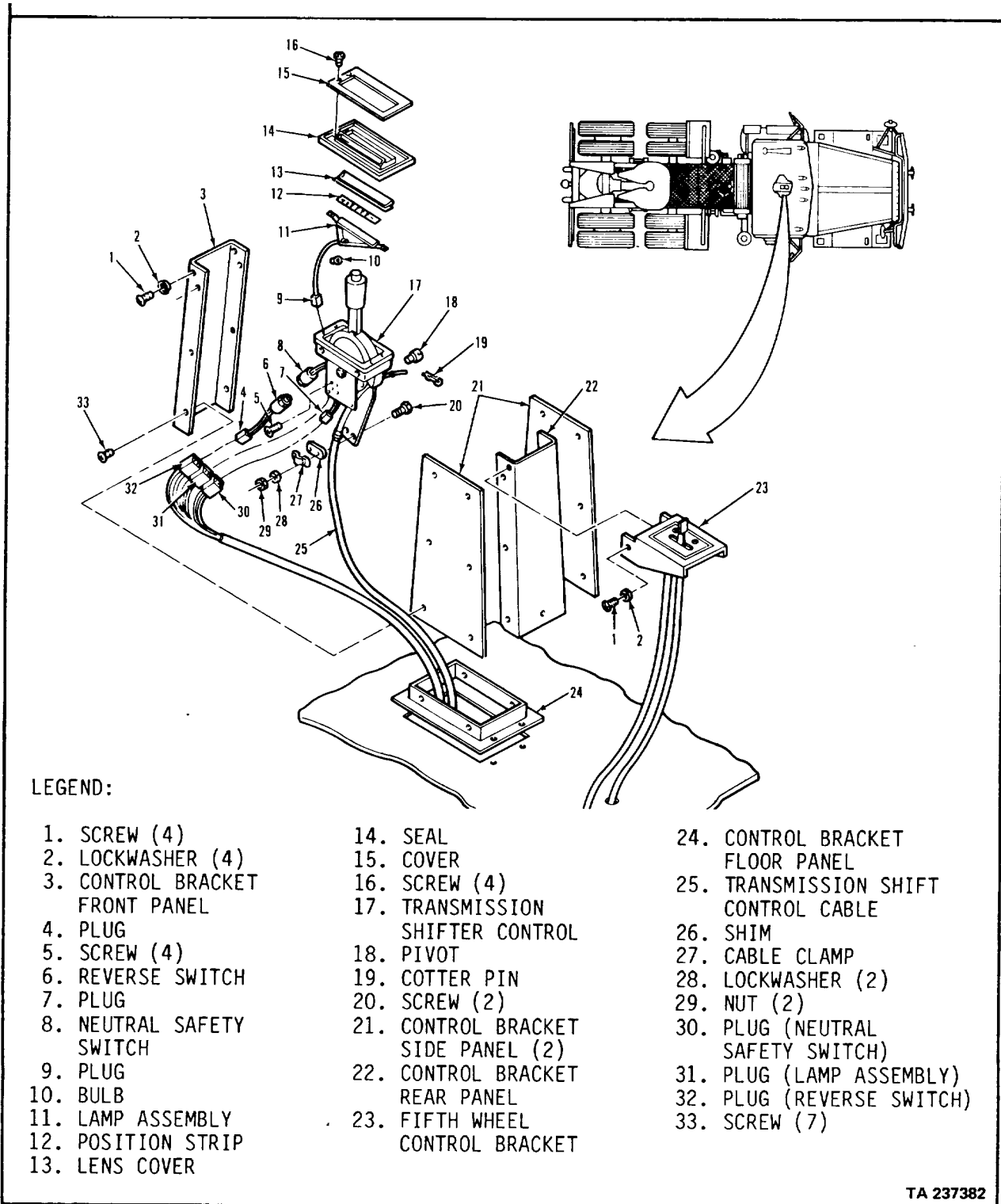

TA 237382

**TRANSMISSION.**

<b>3-138. SHIFTER CONTROL CABLE REPLACEMENT.</b>																																															
<b>LOCATION/ITEM</b>	<b>ACTION</b>	<b>REMARKS</b>																																													
<p><u>THIS TASK COVERS</u></p> <p>a. Removal.                      b. Cleaning and Inspection.                      c. Installation.                      d. Adjustment.</p>																																															
<p><u>INITIAL SETUP</u></p> <table border="0"> <tr> <td><u>APPLICABLE CONFIGURATIONS</u></td> <td><u>EQUIPMENT CONDITION PARAGRAPH</u></td> <td><u>CONDITION DESCRIPTION</u></td> </tr> <tr> <td>All.</td> <td>None.</td> <td>None.</td> </tr> <tr> <td colspan="3"><u>TEST EQUIPMENT</u></td> </tr> <tr> <td colspan="3">None.</td> </tr> <tr> <td colspan="3"><u>SPECIAL TOOLS</u></td> </tr> <tr> <td colspan="3">None.</td> </tr> <tr> <td colspan="3"><u>MATERIALS/PARTS (P/N)</u></td> </tr> <tr> <td colspan="3">Pin, cotter (24617) 9427317.</td> </tr> <tr> <td colspan="3">Pin, cotter (85757) 10166.</td> </tr> <tr> <td><u>PERSONNEL REQUIRED</u></td> <td colspan="2"><u>SPECIAL ENVIRONMENTAL CONDITIONS</u></td> </tr> <tr> <td>One (MOS-63S).</td> <td colspan="2">None.</td> </tr> <tr> <td><u>REFERENCES (TM)</u></td> <td colspan="2"><u>GENERAL SAFETY INSTRUCTIONS</u></td> </tr> <tr> <td>None. Transmission in neutral. Park brake set.</td> <td colspan="2">Engine off.</td> </tr> <tr> <td colspan="3"><u>TROUBLESHOOTING REFERENCES</u></td> </tr> <tr> <td colspan="3">Paragraph 2-11.</td> </tr> </table>			<u>APPLICABLE CONFIGURATIONS</u>	<u>EQUIPMENT CONDITION PARAGRAPH</u>	<u>CONDITION DESCRIPTION</u>	All.	None.	None.	<u>TEST EQUIPMENT</u>			None.			<u>SPECIAL TOOLS</u>			None.			<u>MATERIALS/PARTS (P/N)</u>			Pin, cotter (24617) 9427317.			Pin, cotter (85757) 10166.			<u>PERSONNEL REQUIRED</u>	<u>SPECIAL ENVIRONMENTAL CONDITIONS</u>		One (MOS-63S).	None.		<u>REFERENCES (TM)</u>	<u>GENERAL SAFETY INSTRUCTIONS</u>		None. Transmission in neutral. Park brake set.	Engine off.		<u>TROUBLESHOOTING REFERENCES</u>			Paragraph 2-11.		
<u>APPLICABLE CONFIGURATIONS</u>	<u>EQUIPMENT CONDITION PARAGRAPH</u>	<u>CONDITION DESCRIPTION</u>																																													
All.	None.	None.																																													
<u>TEST EQUIPMENT</u>																																															
None.																																															
<u>SPECIAL TOOLS</u>																																															
None.																																															
<u>MATERIALS/PARTS (P/N)</u>																																															
Pin, cotter (24617) 9427317.																																															
Pin, cotter (85757) 10166.																																															
<u>PERSONNEL REQUIRED</u>	<u>SPECIAL ENVIRONMENTAL CONDITIONS</u>																																														
One (MOS-63S).	None.																																														
<u>REFERENCES (TM)</u>	<u>GENERAL SAFETY INSTRUCTIONS</u>																																														
None. Transmission in neutral. Park brake set.	Engine off.																																														
<u>TROUBLESHOOTING REFERENCES</u>																																															
Paragraph 2-11.																																															
<p><b>3-820</b></p>																																															

TRANSMISSION.

3-138. SHIFTER CONTROL CABLE REPLACEMENT (Continued).

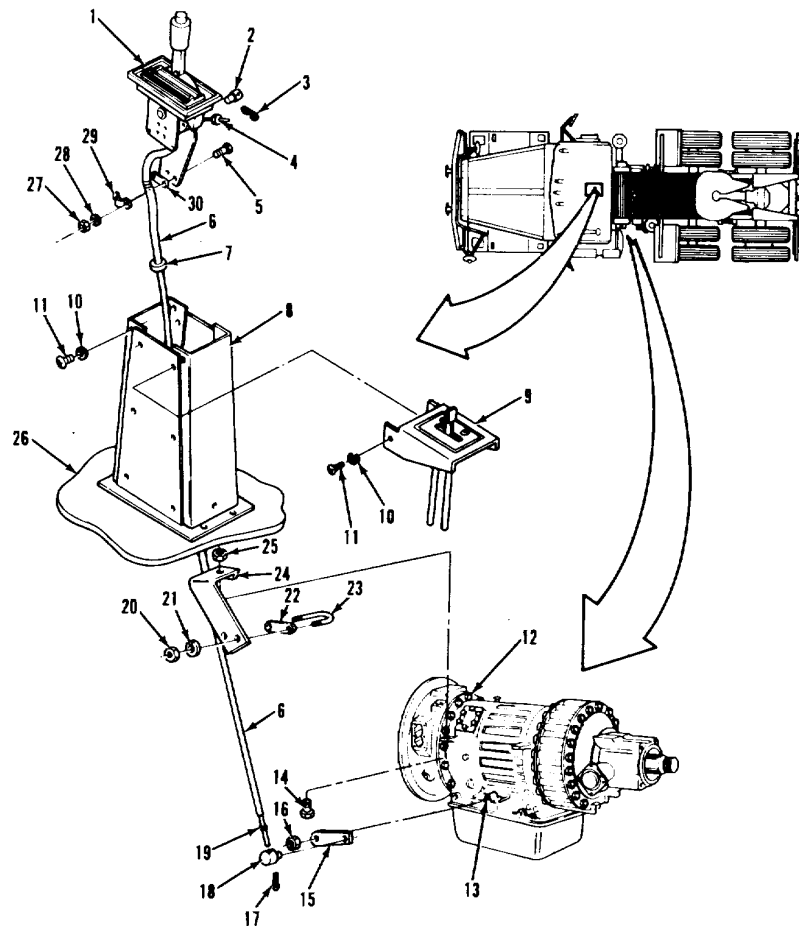

LEGEND:

- |  |                               |   |
|--|-------------------------------|---|
| 1. TRANSMISSION SHIFTER CONTROL          | 10. LOCKWASHER (4)            | 21. LOCKWASHER (2)                            |
| 2. PIVOT                                 | 11. SCREW (4)                 | 22. SHIM                                      |
| 3. COTTER PIN                            | 12. TRANSMISSION ASSEMBLY     | 23. U-BOLT                                    |
| 4. NUT                                   | 13. SELECTOR SHAFT            | 24. TRANSMISSION SHIFT CABLE MOUNTING BRACKET |
| 5. SCREW (2)                             | 14. HEXAGON HEAD SCREW        | 25. LOCKNUT                                   |
| 6. TRANSMISSION SHIFT CONTROL CABLE      | 15. LEVER                     | 26. CAB FLOOR                                 |
| 7. GROMMET                               | 16. SELECTOR SHAFT METRIC NUT | 27. NUT (2)                                   |
| 8. TRANSMISSION CONTROL MOUNTING BRACKET | 17. COTTER PIN                | 28. LOCKWASHER (2)                            |
| 9. FIFTH WHEEL CONTROL BRACKET           | 18. TRUNNION                  | 29. CABLE CLAMP                               |
|  | 19. NUT                       | 30. SHIM                                      |
|  | 20. HEXAGON HEAD LOCKNUT (2)  |   |

TA 237383

**TRANSMISSION.**

<b>3-138. SHIFTER CONTROL CABLE REPLACEMENT (Continued).</b>		
<b>LOCATION/ITEM</b>	<b>ACTION</b>	<b>REMARKS</b>
<b><u>A. REMOVAL.</u></b>		
1. Pin (17).	Remove from item (18).	Discard item (17).
2. Trunnion (18).	Remove from items (15) and (6).	
3. Two locknuts (20), lockwashers (21), shim (22), and U-bolt (23).	Remove from items (6) and (24).	
4. Two screws (11) and lockwashers (10).	Remove from items (9), (8), and (1).	
5. Bracket (9).	Remove from item (8) and set aside.	Do not disconnect air lines.
6. Two other screws (11) and lockwashers (10).	Remove from items (8) and (1).	
7. Control (1).	a. Lift up out of item (8). b. Shift into FIRST GEAR (1).	Be careful not to damage any wiring.
8. Two nuts (27), lockwashers (28), screws (5), clamp (29), and shim (30).	Remove from items (1) and (6).	
9. Pin (3).	Remove from item (2).	Discard item (3).
10. Pivot (2).	Remove from items (1) and (6).	Mark hole location on item (1) for replacement of item (2).

TRANSMISSION.

3-138. SHIFTER CONTROL CABLE REPLACEMENT (Continued)

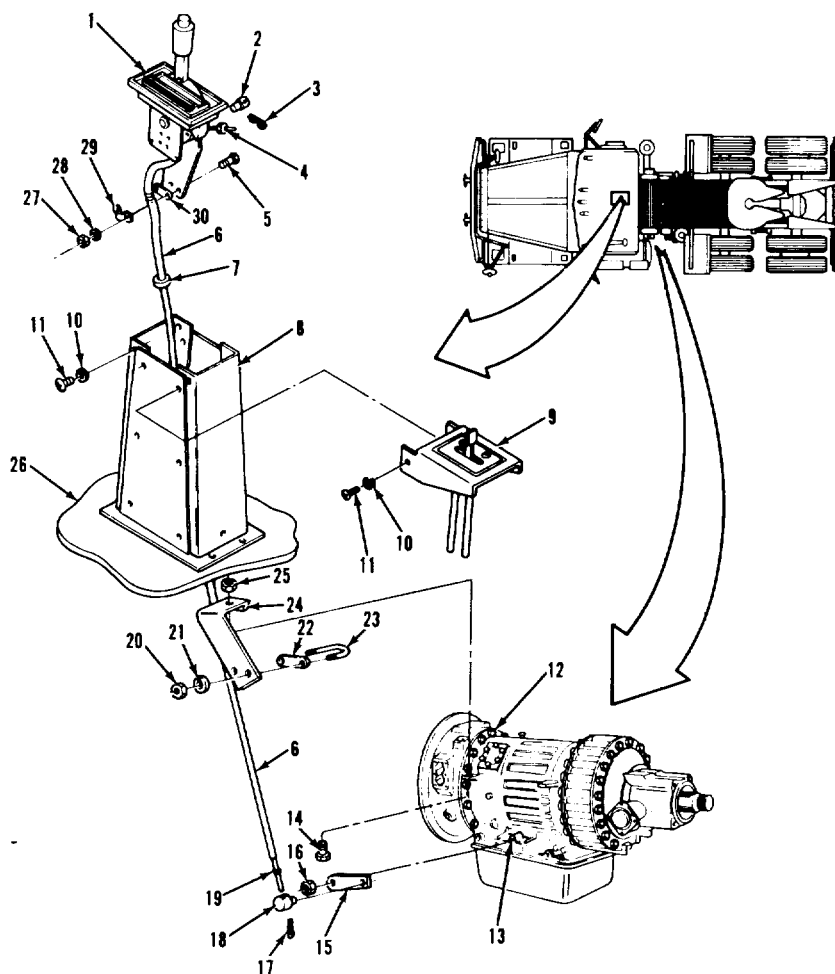

LEGEND:

- |  |                               |   |
|--|-------------------------------|---|
| 1. TRANSMISSION SHIFTER CONTROL          | 10. LOCKWASHER (4)            | 21. LOCKWASHER (2)                            |
| 2. PIVOT                                 | 11. SCREW (4)                 | 22. SHIM                                      |
| 3. COTTER PIN                            | 12. TRANSMISSION ASSEMBLY     | 23. U-BOLT                                    |
| 4. NUT                                   | 13. SELECTOR SHAFT            | 24. TRANSMISSION SHIFT CABLE MOUNTING BRACKET |
| 5. SCREW (2)                             | 14. HEXAGON HEAD SCREW        | 25. LOCKNUT                                   |
| 6. TRANSMISSION SHIFT CONTROL CABLE      | 15. LEVER                     | 26. CAB FLOOR                                 |
| 7. GROMMET                               | 16. SELECTOR SHAFT METRIC NUT | 27. NUT (2)                                   |
| 8. TRANSMISSION CONTROL MOUNTING BRACKET | 17. COTTER PIN                | 28. LOCKWASHER (2)                            |
| 9. FIFTH WHEEL CONTROL BRACKET           | 18. TRUNNION                  | 29. CABLE CLAMP                               |
|  | 19. NUT                       | 30. SHIM                                      |
|  | 20. HEXAGON HEAD LOCKNUT (2)  |   |

TA 237384

**TRANSMISSION.**

<b>3-138. SHIFTER CONTROL CABLE REPLACEMENT (Continued).</b>		
<b>LOCATION/ITEM</b>	<b>ACTION</b>	<b>REMARKS</b>
<b><u>A. REMOVAL (Continued). I</u></b>		
11. Cable (6) and grommet (7).	Pull out from item (26).	
12. Nut (16) and lever (15).	Remove from item (13).	
13. Locknut (25), screw (14), and bracket (24).	Remove from item (12).	
<b><u>B. CLEANING AND INSPECTION. I</u></b>		
14. All parts	Clean and inspect	Refer to paragraphs 3-4 and 3-5. Make sure to clean item (6) of any dirt that could prevent it from shifting.
<b><u>C. INSTALLATION.</u></b>		
15. Bracket (24)	a. Position on item (12). b. Secure with items (14) and (25).	
16. Lever (15)	a. Position on item (13). b. Secure with item (16).	
17. Grommet (7) and cable (6)	Put item (7) in place in item (26), and push item (6) through item (7)	Make sure item (7) is correctly positioned before installing item (6).



TRANSMISSION.

3-138. SHIFTER CONTROL CABLE REPLACEMENT (Continued)

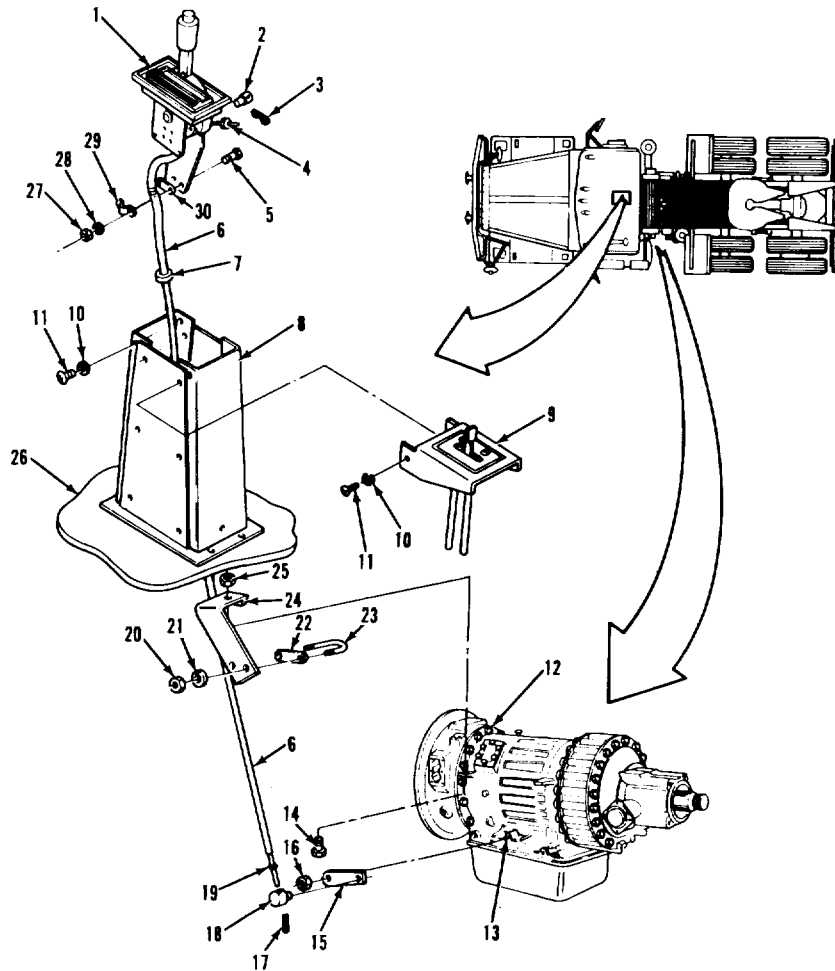

LEGEND:

- |  |                               |   |
|--|-------------------------------|---|
| 1. TRANSMISSION SHIFTER CONTROL          | 10. LOCKWASHER (4)            | 21. LOCKWASHER (2)                            |
| 2. PIVOT                                 | 11. SCREW (4)                 | 22. SHIM                                      |
| 3. COTTER PIN                            | 12. TRANSMISSION ASSEMBLY     | 23. U-BOLT                                    |
| 4. NUT                                   | 13. SELECTOR SHAFT            | 24. TRANSMISSION SHIFT CABLE MOUNTING BRACKET |
| 5. SCREW (2)                             | 14. HEXAGON HEAD SCREW        | 25. LOCKNUT                                   |
| 6. TRANSMISSION SHIFT CONTROL CABLE      | 15. LEVER                     | 26. CAB FLOOR                                 |
| 7. GROMMET                               | 16. SELECTOR SHAFT METRIC NUT | 27. NUT (2)                                   |
| 8. TRANSMISSION CONTROL MOUNTING BRACKET | 17. COTTER PIN                | 28. LOCKWASHER (2)                            |
| 9. FIFTH WHEEL CONTROL BRACKET           | 18. TRUNNION                  | 29. CABLE CLAMP                               |
|  | 19. NUT                       | 30. SHIM                                      |
|  | 20. HEXAGON HEAD LOCKNUT (2)  |   |

TA 237385

## TRANSMISSION.

3-138. SHIFTER CONTROL CABLE REPLACEMENT (Continued).		
LOCATION/ITEM	ACTION	REMARKS
<b><u>IC. INSTALLATION (Continued). !</u></b>		
18. Control (1)	Shift into FIRST GEAR (1).	
19. Pivot (2)	a. Screw onto item (6) and position into item (1)	Align item (2) with correct hole in item (1).
	b. Secure in place with new item (3).	
20. Nut (4)	Tighten against item (2).	
21. Cable (6)	a. Position on item (1).	
b. Secure with items (30),	Be sure to secure metal (29), and two items (5), (28), and (27)	part of item (6) to item (1).
22. Control (1)	Lower into place on item (8).	
23. Two screws (11) and lockwashers (10).	Screw into items (8) and (1), but do not tighten.	
24. Bracket (9)	a. Position on item (8).	
	b. Secure with items (11) and (10)	Other two items (11) and (10) can be tightened at this time.
25. Cable (6)	a. Pull down as far as possible and position on item (24).	
	b. Secure with items (23), (22), and two items (21) and (20).	Be sure to secure metal part of item (6).

TRANSMISSION.

3-138. SHIFTER CONTROL CABLE REPLACEMENT (Continued).

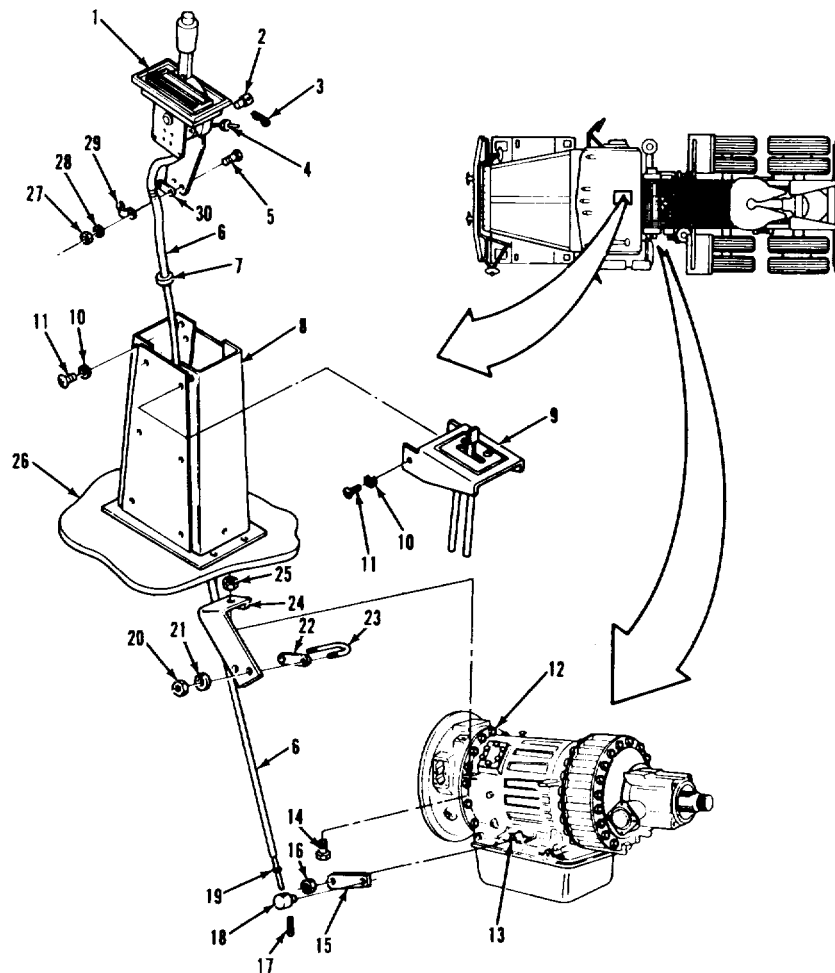

LEGEND:

- |  |                               |   |
|--|-------------------------------|---|
| 1. TRANSMISSION SHIFTER CONTROL          | 10. LOCKWASHER (4)            | 21. LOCKWASHER (2)                            |
| 2. PIVOT                                 | 11. SCREW (4)                 | 22. SHIM                                      |
| 3. COTTER PIN                            | 12. TRANSMISSION ASSEMBLY     | 23. U-BOLT                                    |
| 4. NUT                                   | 13. SELECTOR SHAFT            | 24. TRANSMISSION SHIFT CABLE MOUNTING BRACKET |
| 5. SCREW (2)                             | 14. HEXAGON HEAD SCREW        | 25. LOCKNUT                                   |
| 6. TRANSMISSION SHIFT CONTROL CABLE      | 15. LEVER                     | 26. CAB FLOOR                                 |
| 7. GROMMET                               | 16. SELECTOR SHAFT METRIC NUT | 27. NUT (2)                                   |
| 8. TRANSMISSION CONTROL MOUNTING BRACKET | 17. COTTER PIN                | 28. LOCKWASHER (2)                            |
| 9. FIFTH WHEEL CONTROL BRACKET           | 18. TRUNNION                  | 29. CABLE CLAMP                               |
|  | 19. NUT                       | 30. SHIM                                      |
|  | 20. HEXAGON HEAD LOCKNUT (2)  |   |

TA 237386

**TRANSMISSION.**

3-138. SHIFTER CONTROL CABLE REPLACEMENT (Continued).		
LOCATION/ITEM	ACTION	REMARKS
<b>C. INSTALLATION (Continued). I</b>		
26. Control (1).	Shift into REVERSE (R).	
27. Lever (15).	Rotate counterclockwise as far as possible.	
28. Trunnion (18).	a. Screw onto item (6) until it lines up with hole of item (15).  b. Push into hole of item (15).  c. Secure in place with new item (17).	
29. Nut (19).	Tighten against item (18).	
	<p style="text-align: center;"><b><u>WARNING</u></b>  <b>Improper cable adjustment will cause faulty transmission operation, and possibly lead to personal injury. Be sure to perform the check in step 30 before starting the engine.</b></p>	
30. Control (1).	Shift through all ranges and check for proper operation.	If item (1) is hard to shift or will not shift into one or more ranges, item (6) is not properly adjusted. For proper adjustment procedures, refer to subparagraph D, ADJUSTMENT. If item (1) is shifting properly, go to follow-on maintenance.

TRANSMISSION.

3-138. SHIFTER CONTROL CABLE REPLACEMENT (Continued)

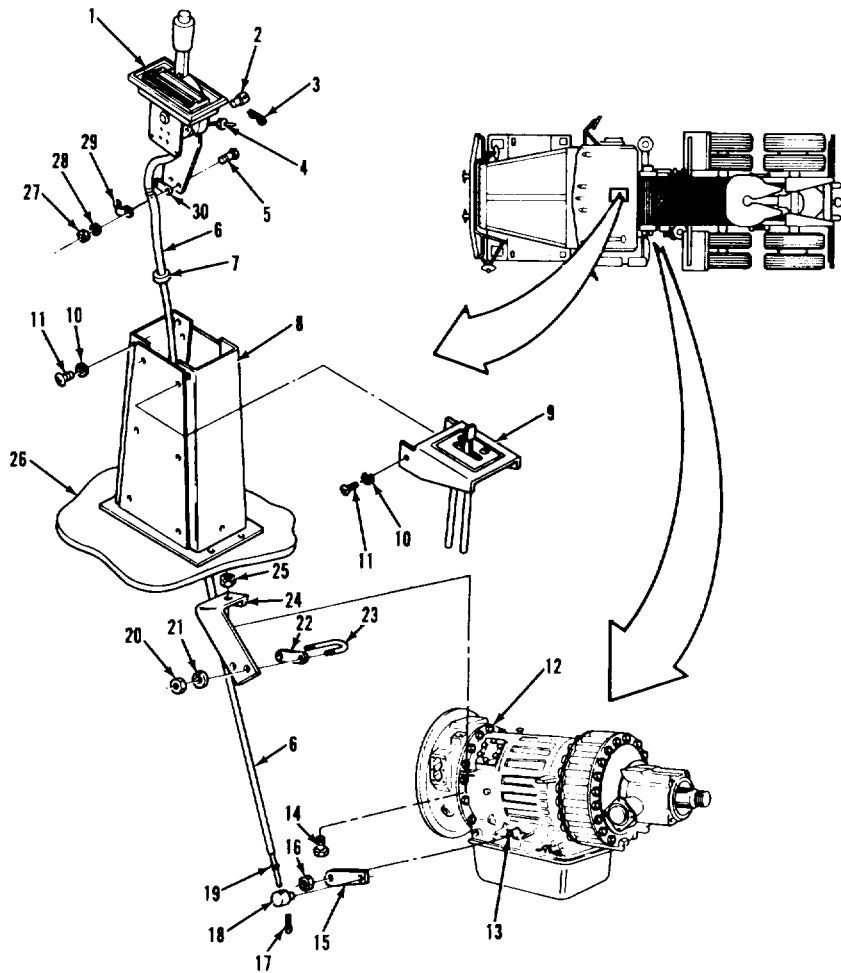

LEGEND:

- |  |                               |   |
|--|-------------------------------|---|
| 1. TRANSMISSION SHIFTER CONTROL          | 10. LOCKWASHER (4)            | 21. LOCKWASHER (2)                            |
| 2. PIVOT                                 | 11. SCREW (4)                 | 22. SHIM                                      |
| 3. COTTER PIN                            | 12. TRANSMISSION ASSEMBLY     | 23. U-BOLT                                    |
| 4. NUT                                   | 13. SELECTOR SHAFT            | 24. TRANSMISSION SHIFT CABLE MOUNTING BRACKET |
| 5. SCREW (2)                             | 14. HEXAGON HEAD SCREW        | 25. LOCKNUT                                   |
| 6. TRANSMISSION SHIFT CONTROL CABLE      | 15. LEVER                     | 26. CAB FLOOR                                 |
| 7. GROMMET                               | 16. SELECTOR SHAFT METRIC NUT | 27. NUT (2)                                   |
| 8. TRANSMISSION CONTROL MOUNTING BRACKET | 17. COTTER PIN                | 28. LOCKWASHER (2)                            |
| 9. FIFTH WHEEL CONTROL BRACKET           | 18. TRUNNION                  | 29. CABLE CLAMP                               |
|  | 19. NUT                       | 30. SHIM                                      |
|  | 20. HEXAGON HEAD LOCKNUT (2)  |   |

TA 237387

## TRANSMISSION.

3-138. SHIFTER CONTROL CABLE REPLACEMENT (Continued).		
LOCATION/ITEM	ACTION	REMARKS
D. ADJUSTMENT. I		
31. Pin (17).	Remove from item (18).	Discard item (17).
32. Trunnion (18).	Remove from item (15).	
33. Nut (19).	Loosen.	
34. Control (1), lever (15), trunnion (18), and nut (19).	Do steps 26 thru 30.	
<b>NOTE</b>		
<b>Follow-on maintenance action required:</b>		
None.		
3-830		

TRANSMISSION.

3-138. SHIFTER CONTROL CABLE REPLACEMENT (Continued).

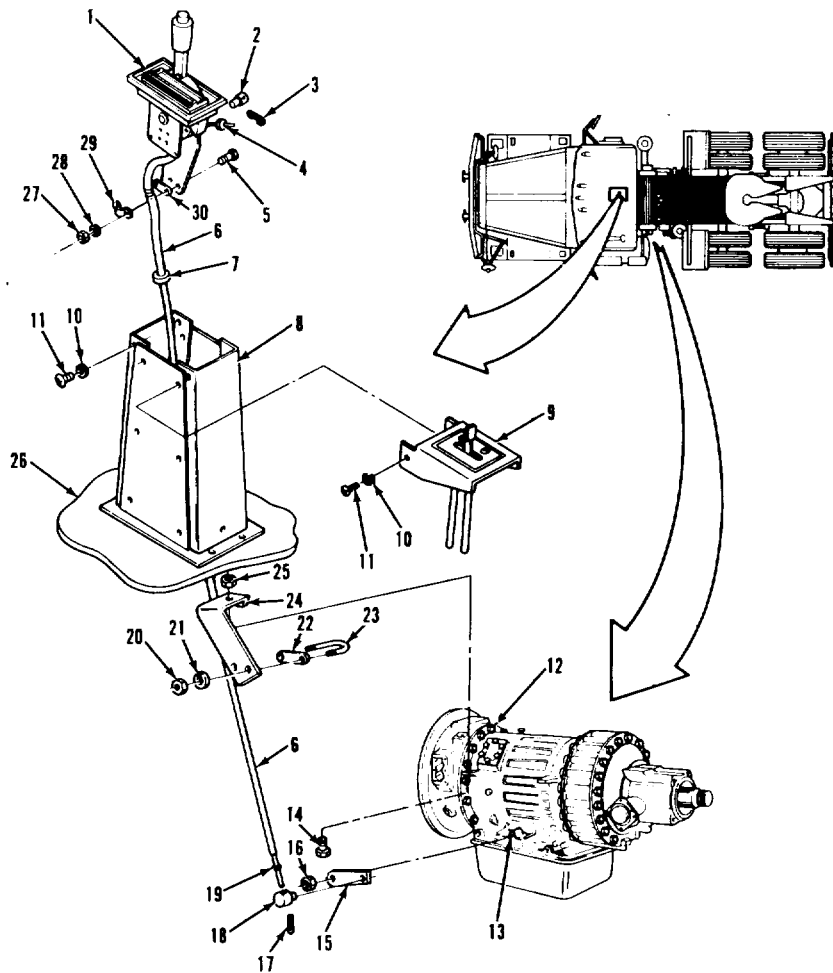

LEGEND:

- |  |                               |   |
|--|-------------------------------|---|
| 1. TRANSMISSION SHIFTER CONTROL          | 10. LOCKWASHER (4)            | 21. LOCKWASHER (2)                            |
| 2. PIVOT                                 | 11. SCREW (4)                 | 22. SHIM                                      |
| 3. COTTER PIN                            | 12. TRANSMISSION ASSEMBLY     | 23. U-BOLT                                    |
| 4. NUT                                   | 13. SELECTOR SHAFT            | 24. TRANSMISSION SHIFT CABLE MOUNTING BRACKET |
| 5. SCREW (2)                             | 14. HEXAGON HEAD SCREW        | 25. LOCKNUT                                   |
| 6. TRANSMISSION SHIFT CONTROL CABLE      | 15. LEVER                     | 26. CAB FLOOR                                 |
| 7. GROMMET                               | 16. SELECTOR SHAFT METRIC NUT | 27. NUT (2)                                   |
| 8. TRANSMISSION CONTROL MOUNTING BRACKET | 17. COTTER PIN                | 28. LOCKWASHER (2)                            |
| 9. FIFTH WHEEL CONTROL BRACKET           | 18. TRUNNION                  | 29. CABLE CLAMP                               |
|  | 19. NUT                       | 30. SHIM                                      |
|  | 20. HEXAGON HEAD LOCKNUT (2)  |   |

TA 237388

**TRANSMISSION.**

**3-139. SHIFTER CONTROL MOUNTING BRACKET REPLACEMENT.**

**THIS TASK COVERS**

- a. Removal.
- b. Cleaning and Inspection.
- c. Installation.

INITIAL SETUP

<u>APPLICABLE CONFIGURATIONS</u> All	<u>EQUIPMENT CONDITION PARAGRAPH</u> None	<u>CONDITION DESCRIPTION</u> None.
---	--	---------------------------------------

TEST EQUIPMENT  
None.

SPECIAL TOOLS  
None.

MATERIALS/PARTS (P/N)  
None.

<u>PERSONNEL REQUIRED</u> One (MOS-63S)	<u>SPECIAL ENVIRONMENTAL CONDITIONS</u> None.
--	--

<u>REFERENCES (TM)</u> None	<u>GENERAL SAFETY INSTRUCTIONS</u> Engine off. Transmission in neutral. Park brake set.
--------------------------------	--

TROUBLESHOOTING REFERENCES  
None.



TRANSMISSION.

**3-139. SHIFTER CONTROL MOUNTING BRACKET REPLACEMENT (Continued).**

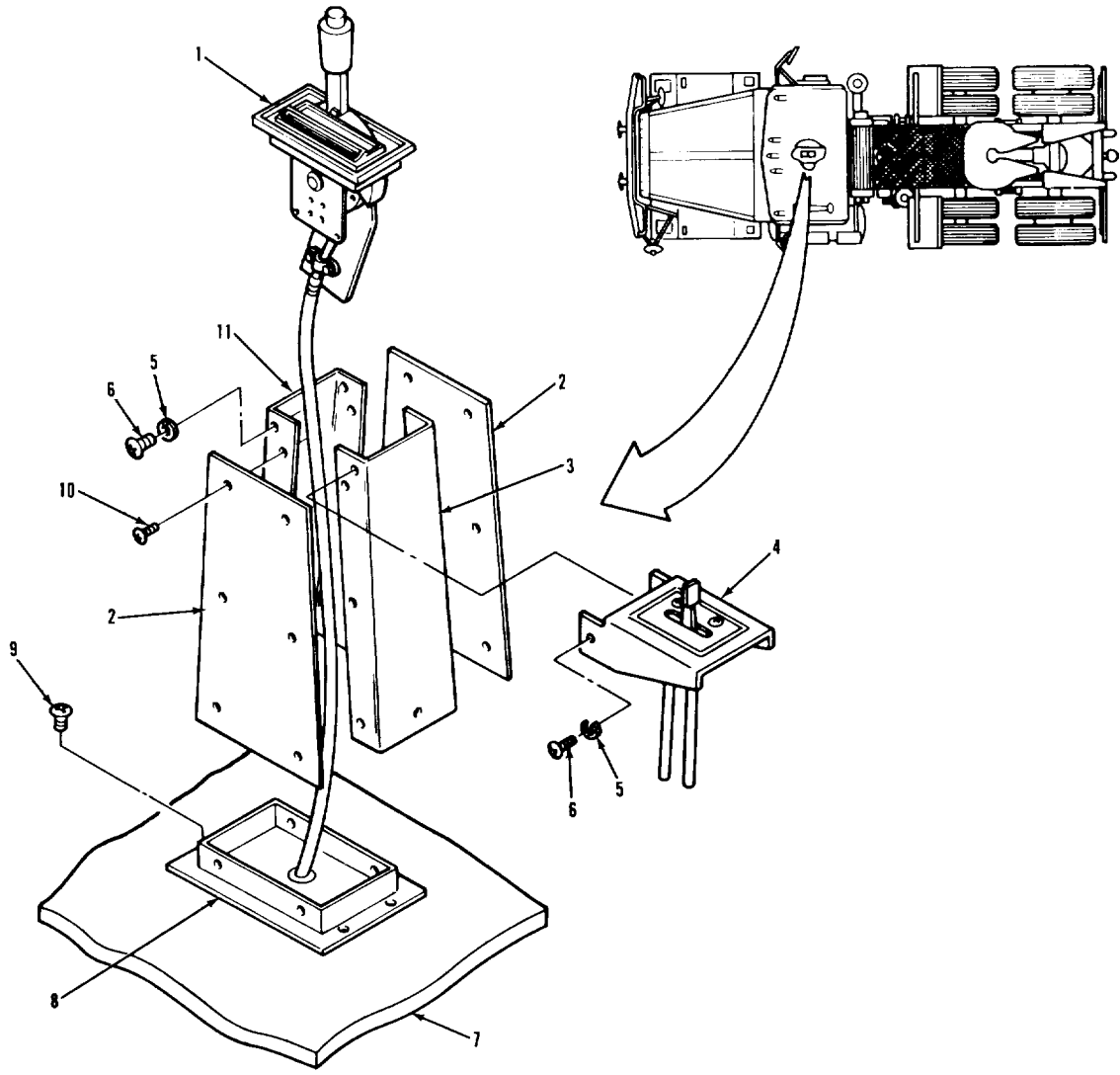

LEGEND:

- |                                   |                                 |
|-----------------------------------|---------------------------------|
| 1. TRANSMISSION SHIFTER CONTROL   | 7. CAB FLOOR                    |
| 2. CONTROL BRACKET SIDE PANEL (2) | 8. CONTROL BRACKET FLOOR PANEL  |
| 3. CONTROL BRACKET REAR PANEL     | 9. SCREW (4)                    |
| 4. FIFTH WHEEL CONTROL BRACKET    | 10. SCREW (14)                  |
| 5. LOCKWASHER (4)                 | 11. CONTROL BRACKET FRONT PANEL |
| 6. SCREW (4)                      |                                 |

TA 237389

**TRANSMISSION.**

<b>3-139. SHIFTER CONTROL MOUNTING BRACKET REPLACEMENT (Continued).</b>		
<b>LOCATION/ITEM</b>	<b>ACTION</b>	<b>REMARKS</b>
<b><u>A. REMOVAL. I</u></b>		
1. Two screws (6) and lockwashers (5)	Remove from items (4), (3), and (1).	
2. Bracket (4) aside	Remove from item (3) and set aside	Do not disconnect air lines.
3. Two other screws (6) and lockwashers (5).	Remove from items (11) and (1).	
4. Fourteen screws (10) and four panels (2), (3), and (11).	Disassemble and remove from items (1) and (8) to damage cable or wires.	Set item (1) on cab floor. Be careful not
5. Four screws (9) and panel (8)	Remove from items (7) and (1).	
<b><u>B. CLEANING AND INSPECTION. I</u></b>		
6. All parts	Clean and inspect	Refer to paragraphs 3-4 and 3-5.
<b><u>C. INSTALLATION. I</u></b>		
7. Panel (8)	a. Put over item (1) and position on item (7).	
	b. Secure with four items (9).	
8. Four panels (2), (3), and (11), and fourteen screws (10).	Install on items (7) and (1) and assemble.	

TRANSMISSION.

**3-139. SHIFTER CONTROL MOUNTING BRACKET REPLACEMENT (Continued)**

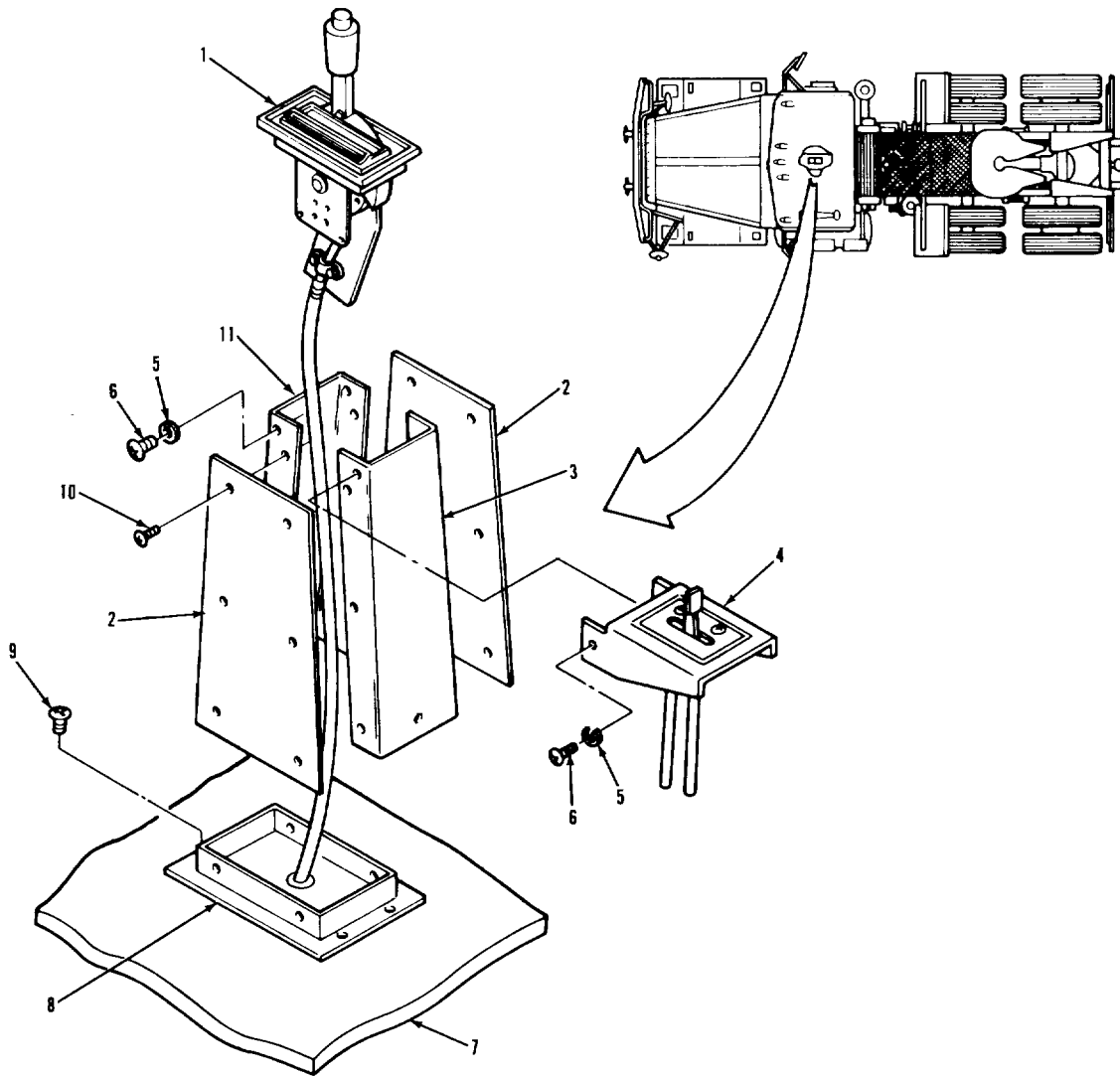

LEGEND:

- |                                   |                                 |
|-----------------------------------|---------------------------------|
| 1. TRANSMISSION SHIFTER CONTROL   | 7. CAB FLOOR                    |
| 2. CONTROL BRACKET SIDE PANEL (2) | 8. CONTROL BRACKET FLOOR PANEL  |
| 3. CONTROL BRACKET REAR PANEL     | 9. SCREW (4)                    |
| 4. FIFTH WHEEL CONTROL BRACKET    | 10. SCREW (14)                  |
| 5. LOCKWASHER (4)                 | 11. CONTROL BRACKET FRONT PANEL |
| 6. SCREW (4)                      |                                 |

TA 237390

TRANSMISSION.

3-139. SHIFTER CONTROL MOUNTING BRACKET REPLACEMENT (Continued).		
LOCATION/ITEM	ACTION	REMARKS
<b>C. INSTALLATION (Continued). !</b>		
9. Two screws (6) and lockwashers (5).	Screw into items (11) and (1), but do not tighten.	
10. Bracket (4)	a. Position on item (3).  b. Secure with two items (6) and (5)	Other two items (6) and (5) can be tightened at this time.
<p><b>NOTE</b> Follow-on maintenance action required: None.</p>		
<p><b>3-836</b></p>		

TRANSMISSION.

3-139. SHIFTER CONTROL MOUNTING BRACKET REPLACEMENT (Continued)

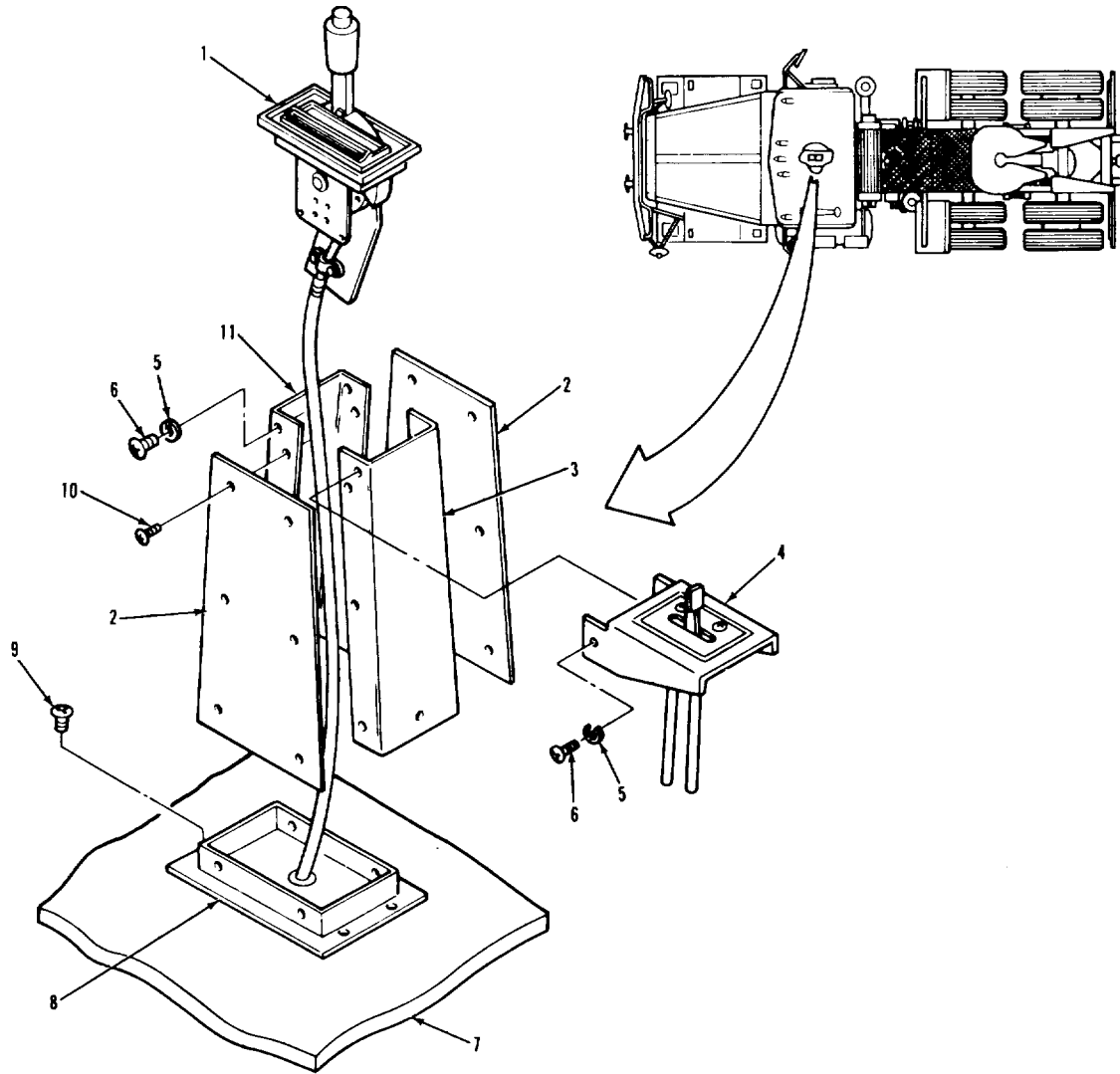

LEGEND:

- |                                   |                                 |
|-----------------------------------|---------------------------------|
| 1. TRANSMISSION SHIFTER CONTROL   | 7. CAB FLOOR                    |
| 2. CONTROL BRACKET SIDE PANEL (2) | 8. CONTROL BRACKET FLOOR PANEL  |
| 3. CONTROL BRACKET REAR PANEL     | 9. SCREW (4)                    |
| 4. FIFTH WHEEL CONTROL BRACKET    | 10. SCREW (14)                  |
| 5. LOCKWASHER (4)                 | 11. CONTROL BRACKET FRONT PANEL |
| 6. SCREW (4)                      |                                 |

TA 237391

**TRANSMISSION.**

**3-140. MODULATOR CONTROL REPLACEMENT.**

**THIS TASK COVERS**

- a. Removal.
- b. Cleaning and Inspection.
- c. Installation.
- d. Adjustment.

**INITIAL SETUP**

<u>APPLICABLE CONFIGURATIONS</u>	<u>EQUIPMENT CONDITION PARAGRAPH</u>	<u>CONDITION DESCRIPTION</u>
All	None	None.

**TEST EQUIPMENT**

None.

**SPECIAL TOOLS**

None.

**MATERIALS/PARTS (P/N)**

Oil, lubricating: OE/HDO-10  
 Item 15, Appendix C.  
 O-ring  
 (85757) 2117.  
 Pin, cotter  
 (85757) 10087-2.

**PERSONNEL REQUIRED**

Two (MOS-63S)

**SPECIAL ENVIRONMENTAL CONDITIONS**

None.

**REFERENCES (TM)**

TM 9-2320-283-10  
 TM 9-2320-283-20P

**GENERAL SAFETY INSTRUCTIONS**

Engine off.  
 Transmission in neutral.  
 Park brake set.

**TROUBLESHOOTING REFERENCES**

Paragraph 2-11.

TRANSMISSION.

**3-140. MODULATOR CONTROL REPLACEMENT (Continued)**

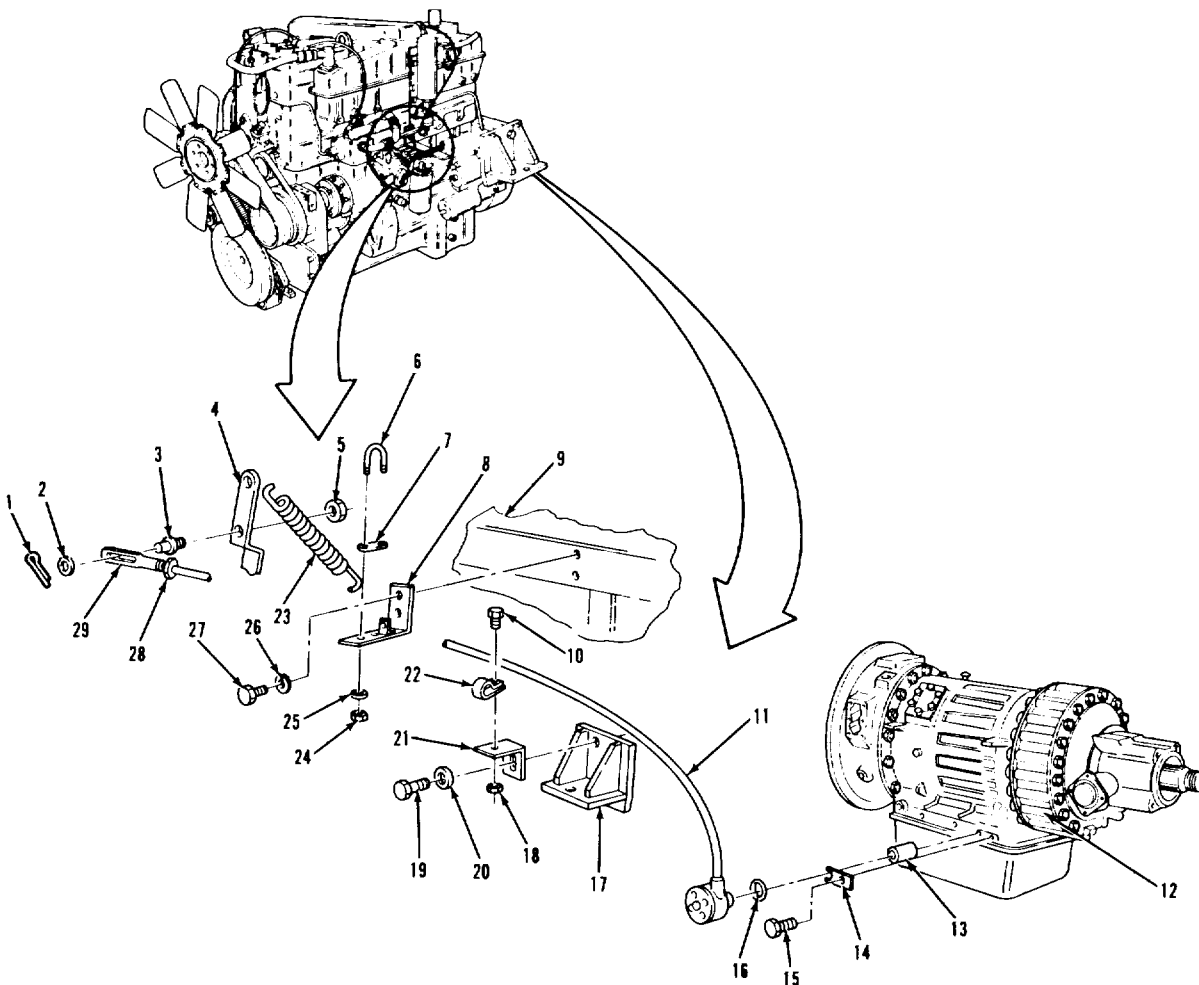

LEGEND:

- |   |                               |
|---|-------------------------------|
| 1. COTTER PIN                               | 15. HEXAGON HEAD SCREW        |
| 2. FLAT WASHER                              | 16. O-RING                    |
| 3. LINK PIN                                 | 17. ENGINE MOUNTING BRACKET   |
| 4. THROTTLE CONTROL LEVER                   | 18. HEXAGON HEAD NUT          |
| 5. HEXAGON HEAD LOCKNUT                     | 19. HEXAGON HEAD CAPSCREW     |
| 6. U-BOLT                                   | 20. FLAT WASHER               |
| 7. SHIM                                     | 21. BRACKET                   |
| 8. MODULATOR BRACKET ASSEMBLY               | 22. CLIP                      |
| 9. ENGINE BLOCK                             | 23. ACCELERATOR RETURN SPRING |
| 10. HEXAGON HEAD SCREW                      | 24. HEXAGON HEAD LOCKNUT (2)  |
| 11. TRANSMISSION MODULATOR CONTROL ASSEMBLY | 25. FLAT WASHER (2)           |
| 12. TRANSMISSION HOUSING                    | 26. LOCKWASHER (2)            |
| 13. VALVE SPACER                            | 27. HEXAGON HEAD SCREW (2)    |
| 14. MODULATOR TO HOUSING RETAINER           | 28. NUT                       |
|   | 29. SLIP LINK                 |

TA 237392

**TRANSMISSION.**

<b>3-140. MODULATOR CONTROL REPLACEMENT (Continued).</b>		
<b>LOCATION/ITEM</b>	<b>ACTION</b>	<b>REMARKS</b>
<b>A. REMOVAL. I</b>		
1. Screw (15) and retainer (14).	Remove from item (12).	
2. Control (11), O-ring (16), and spacer (13)	Remove from item (12)	Discard item (16). Put item (13) in a safe place.
3. Nut (18), screw (10), and clip (22).	Remove from items (21) and (11).	
4. Two locknuts (24), washer (25), shim (7), and U-bolt (6).	Remove from items (8) and (11).	
5. Pin (1), washer (2), and link (29)	Remove from item (3), and pull item (11) out from under vehicle.	Discard item (1).
6. Locknut (5) and pin (3).	Remove from item (4).	
7. Spring (23)	Remove from item (8).	
8. Two screws (27), lockwashers (26), and bracket (8).	Remove from item (9).	
9. Cap screw (19), washer (20), and bracket (21).	Remove from item (17).	
<b><u>B. CLEANING AND INSPECTION. I</u></b>		
10. All parts	Clean and inspect	Refer to paragraphs 3-4 and 3-5. If item (29) is damaged, remove from item (11) and replace.
11. Control (11)	Check for proper operation of cable	Cable should have a total travel of 1.5 inches from "at rest" position.



TRANSMISSION.

3-140. MODULATOR CONTROL REPLACEMENT (Continued).

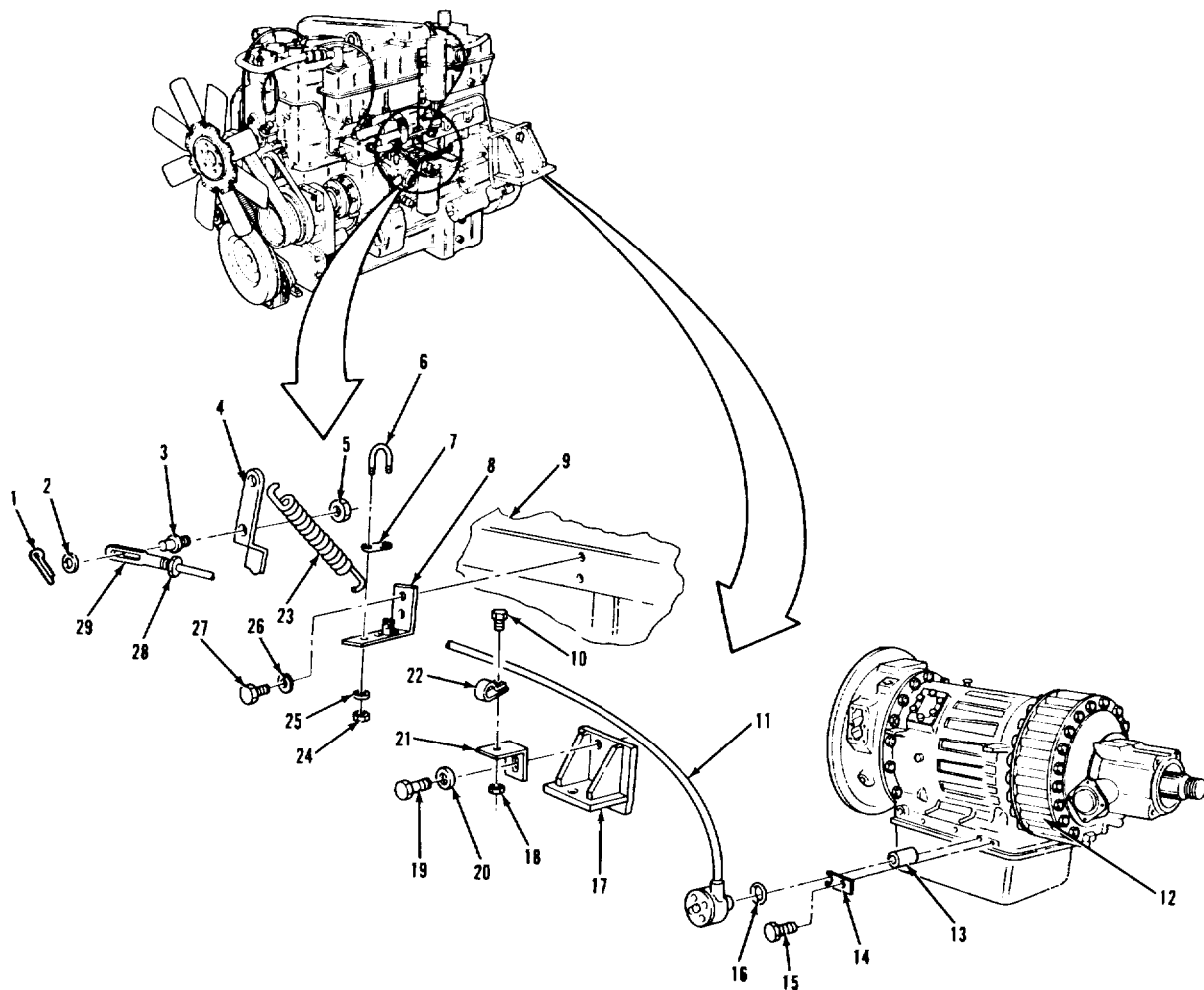

LEGEND:

- |   |                               |
|---|-------------------------------|
| 1. COTTER PIN                               | 15. HEXAGON HEAD SCREW        |
| 2. FLAT WASHER                              | 16. O-RING                    |
| 3. LINK PIN                                 | 17. ENGINE MOUNTING BRACKET   |
| 4. THROTTLE CONTROL LEVER                   | 18. HEXAGON HEAD NUT          |
| 5. HEXAGON HEAD LOCKNUT                     | 19. HEXAGON HEAD CAPSCREW     |
| 6. U-BOLT                                   | 20. FLAT WASHER               |
| 7. SHIM                                     | 21. BRACKET                   |
| 8. MODULATOR BRACKET ASSEMBLY               | 22. CLIP                      |
| 9. ENGINE BLOCK                             | 23. ACCELERATOR RETURN SPRING |
| 10. HEXAGON HEAD SCREW                      | 24. HEXAGON HEAD LOCKNUT (2)  |
| 11. TRANSMISSION MODULATOR CONTROL ASSEMBLY | 25. FLAT WASHER (2)           |
| 12. TRANSMISSION HOUSING                    | 26. LOCKWASHER (2)            |
| 13. VALVE SPACER                            | 27. HEXAGON HEAD SCREW (2)    |
| 14. MODULATOR TO HOUSING RETAINER           | 28. NUT                       |
|   | 29. SLIP LINK                 |

TA 237393

## TRANSMISSION.

3-140. MODULATOR CONTROL REPLACEMENT (Continued).		
LOCATION/ITEM	ACTION	REMARKS
<b><u>C. INSTALLATION. I</u></b>		
12. Bracket (21)	a. Position on item (17). b. Secure with items (19) and (20).	
13. Bracket (8)	a. Position on item (9). b. Secure with two items (27) and (26).	
14. Spring (23)	Install on item (8).	
15. Pin (3) and lock-nut (5).	Install on item (4).	
16. Control (11)	Put in position under vehicle.	
17. Link (29)	a. Position on item (3). b. Secure with item (2) and new item (1)	Do not bend ends of item (1) over yet.
18. Control (11), new O-ring (16), and spacer (13).	a. Lubricate item (16) and install it on item (11). b. Install into item (12)	Be careful not to damage item (16) during installation.
19. Retainer (14)	a. Put in position on items (11) and (12). b. Secure with item (15)	Torque item (15) to 180-240 lb.-in.
20. Clip (22)	a. Position on items (11) and (21). b. Secure with items (10) and (18).	
21. U-bolt (6) and shim (7)	a. Position on items (11) and (8). b. Secure with two items (24) and (25)	
	<b>3-842</b>	

TRANSMISSION.

3-140. MODULATOR CONTROL REPLACEMENT (Continued).

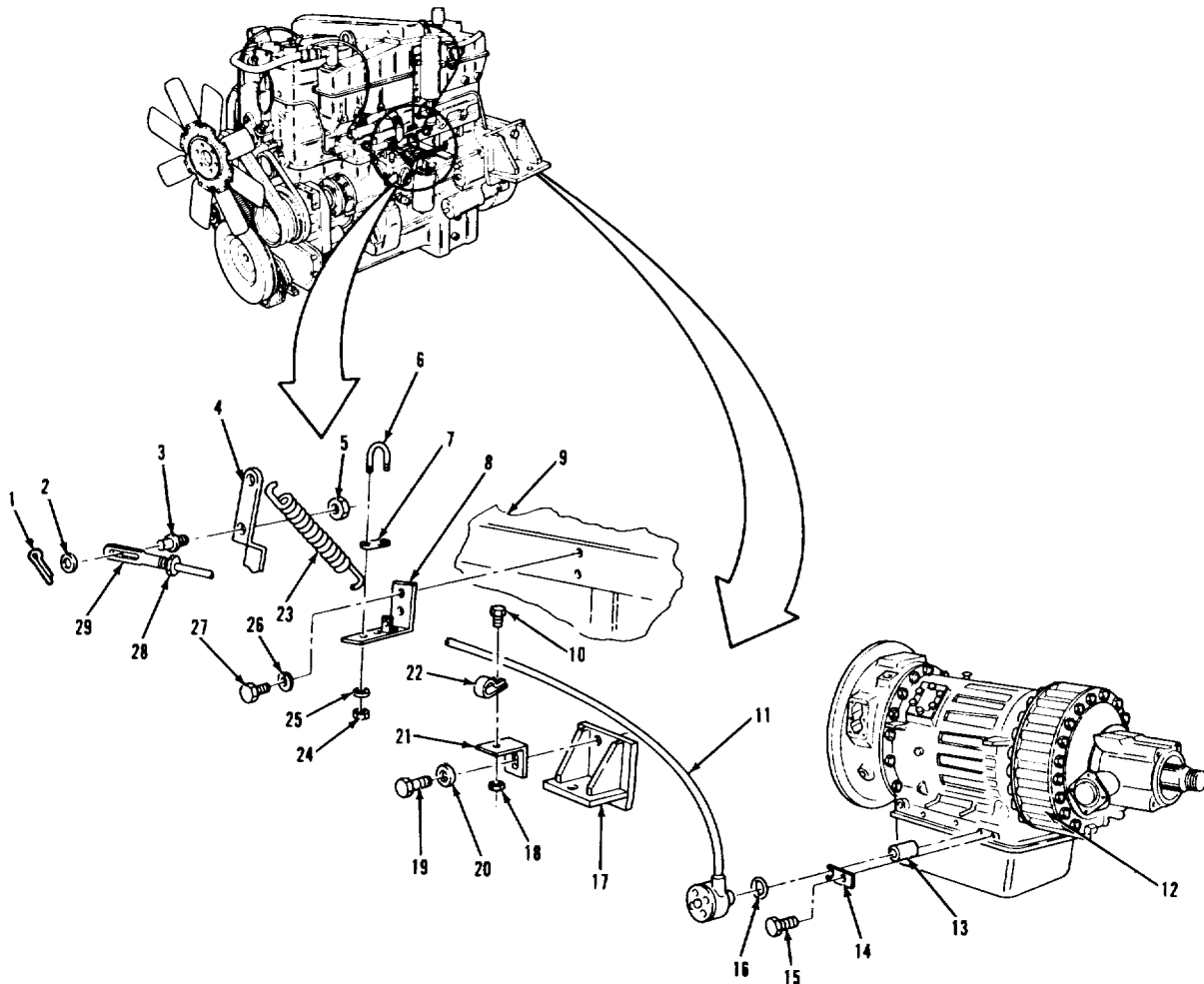

LEGEND:

- |   |                               |
|---|-------------------------------|
| 1. COTTER PIN                               | 15. HEXAGON HEAD SCREW        |
| 2. FLAT WASHER                              | 16. O-RING                    |
| 3. LINK PIN                                 | 17. ENGINE MOUNTING BRACKET   |
| 4. THROTTLE CONTROL LEVER                   | 18. HEXAGON HEAD NUT          |
| 5. HEXAGON HEAD LOCKNUT                     | 19. HEXAGON HEAD CAPSCREW     |
| 6. U-BOLT                                   | 20. FLAT WASHER               |
| 7. SHIM                                     | 21. BRACKET                   |
| 8. MODULATOR BRACKET ASSEMBLY               | 22. CLIP                      |
| 9. ENGINE BLOCK                             | 23. ACCELERATOR RETURN SPRING |
| 10. HEXAGON HEAD SCREW                      | 24. HEXAGON HEAD LOCKNUT (2)  |
| 11. TRANSMISSION MODULATOR CONTROL ASSEMBLY | 25. FLAT WASHER (2)           |
| 12. TRANSMISSION HOUSING                    | 26. LOCKWASHER (2)            |
| 13. VALVE SPACER                            | 27. HEXAGON HEAD SCREW (2)    |
| 14. MODULATOR TO HOUSING RETAINER           | 28. NUT                       |
|   | 29. SLIP LINK                 |

TA 237394

**TRANSMISSION.**

3-140. MODULATOR CONTROL REPLACEMENT (Continued).		
LOCATION/ITEM	ACTION	REMARKS
<u>D. ADJUSTMENT.</u>		
22. Pin (1), washer (2), and link (29).	Remove from item (3)	Discard item (1).
23. Lever (4)	Have assistant depress accelerator pedal until in fully open position.	
24. Link (29) and nut (28)	a. Pull out item (29) as far as possible.	
	b. Loosen item (28) and adjust item (29) until forward end of slot fits freely over item (3).	
	c. Tighten item (28).	
	d. Secure with item (2) and new item (1)	Bend ends of item (1) over.
	e. Check length of travel of item (29) while assistant releases accelerator pedal allowing item (4) to return to fully closed position.	Length of travel should be at least 1.187 inches, but not more than 1.56 inches. Repeat adjustment if necessary.
<b>NOTE</b>		
<b>Follow-on maintenance action required:</b>		
.Road test vehicle and check for proper idle speed and shift speeds (TM 9-2320-283-10).		

TRANSMISSION.

**3-140. MODULATOR CONTROL REPLACEMENT (Continued).**

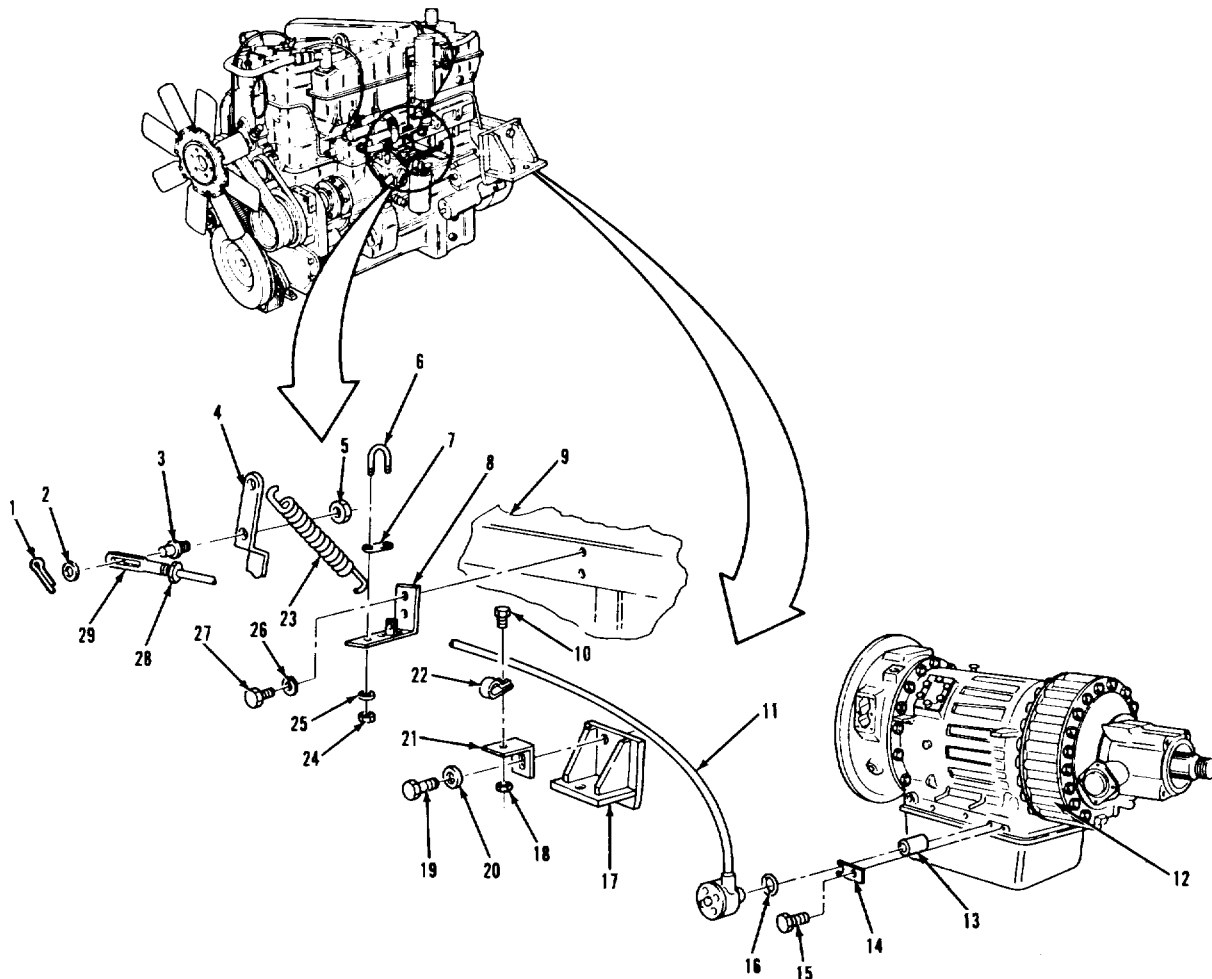

LEGEND:

- |   |                               |
|---|-------------------------------|
| 1. COTTER PIN                               | 15. HEXAGON HEAD SCREW        |
| 2. FLAT WASHER                              | 16. O-RING                    |
| 3. LINK PIN                                 | 17. ENGINE MOUNTING BRACKET   |
| 4. THROTTLE CONTROL LEVER                   | 18. HEXAGON HEAD NUT          |
| 5. HEXAGON HEAD LOCKNUT                     | 19. HEXAGON HEAD CAPSCREW     |
| 6. U-BOLT                                   | 20. FLAT WASHER               |
| 7. SHIM                                     | 21. BRACKET                   |
| 8. MODULATOR BRACKET ASSEMBLY               | 22. CLIP                      |
| 9. ENGINE BLOCK                             | 23. ACCELERATOR RETURN SPRING |
| 10. HEXAGON HEAD SCREW                      | 24. HEXAGON HEAD LOCKNUT (2)  |
| 11. TRANSMISSION MODULATOR CONTROL ASSEMBLY | 25. FLAT WASHER (2)           |
| 12. TRANSMISSION HOUSING                    | 26. LOCKWASHER (2)            |
| 13. VALVE SPACER                            | 27. HEXAGON HEAD SCREW (2)    |
| 14. MODULATOR TO HOUSING RETAINER           | 28. NUT                       |
|   | 29. SLIP LINK                 |

TA 237395

**TRANSMISSION.**

**3-141. LINES AND FITTINGS REPLACEMENT.**

**THIS TASK COVERS**

- a. External Oil Filter Lines and Fittings Replacement.
- b. Oil Cooler Lines and Fittings Replacement.

INITIAL SETUP

<u>APPLICABLE CONFIGURATIONS</u> All.	<u>EQUIPMENT CONDITION PARAGRAPH</u> None.	<u>CONDITION DESCRIPTION</u> None.
--	---	---------------------------------------

TEST EQUIPMENT  
None.

SPECIAL TOOLS  
None.

MATERIALS/PARTS (P/N)  
Tape, thread sealing  
Item 32, Appendix C.  
Oil, lubricating: OE/HDO-10  
Item 15, Appendix C.  
Tie, cable (2)  
(06383) PLT4H-LO.  
O-ring (as required)  
(24617) 274251.

<u>PERSONNEL REQUIRED</u> One (MOS-63S .	<u>SPECIAL ENVIRONMENTAL CONDITIONS</u> None.
---	--

<u>REFERENCES (TM)</u> TM 9-2320-283-10. TM 9-2320-283-20P.	<u>GENERAL SAFETY INSTRUCTIONS</u> Engine off. Transmission in neutral. Park brake set.
---	--

TROUBLESHOOTING REFERENCES  
None.

TRANSMISSION.

3-141. LINES AND FITTINGS REPLACEMENT (Continued).

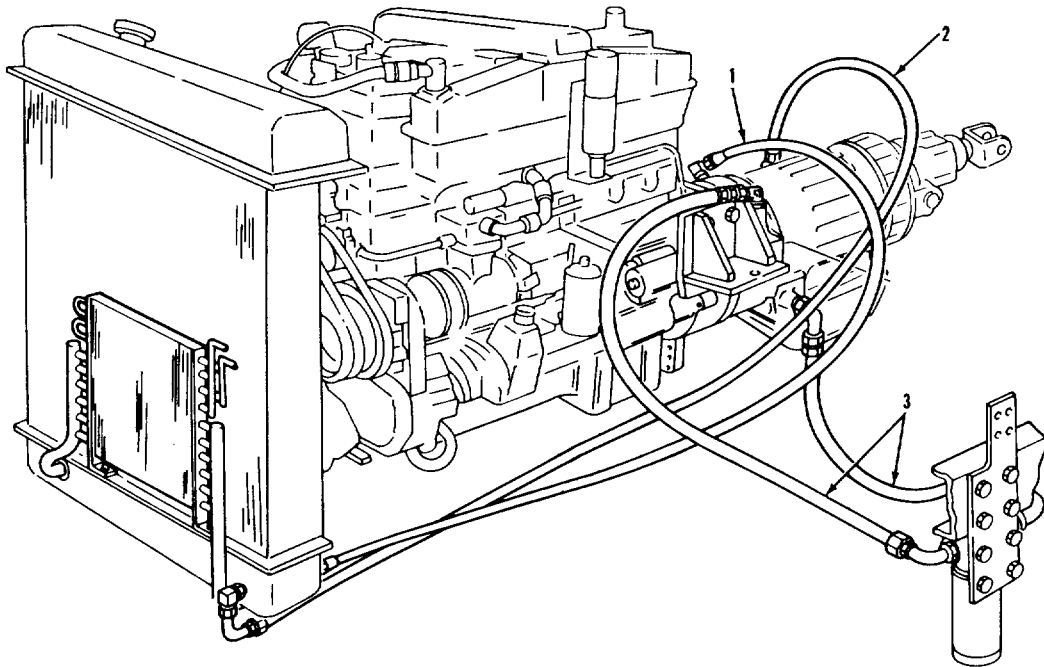

LEGEND:

1. COOLER RETURN HOSE ASSEMBLY
2. COOLER SUPPLY HOSE ASSEMBLY
3. TRANSMISSION TO FILTER HOSE ASSEMBLY (2)

TA 237396

**TRANSMISSION.**

3-141. LINES AND FITTINGS REPLACEMENT (Continued).		
LOCATION/ITEM	ACTION	REMARKS
<b><u>A. EXTERNAL OIL FILTER LINES AND FITTINGS REPLACEMENT. I</u></b>		
<p><b>NOTE</b>                      There are two transmission to filter hose assemblies. Both are shown in the illustration, but only one is covered in the text Since they are similar, use this procedure for replacing either assembly.</p>		
1. Hose (3) any oil from item (3).	Remove from items (4) and (8)	Have a suitable container ready to catch
2. Elbow (4), elbow (8), and two O-rings (5).	Remove from items (6) and (7).	Discard items (5).
3. All parts	Clean and inspect	Refer to paragraph 3-4 and 3-5.
4. Elbow (4), elbow (8), and two new O-rings (5)	a. Wrap threads of items (4) and (8) with thread sealing tape.  b. Coat two items (5) with clean lubricating oil.  c. Install into items (6) and (7).	Refer to paragraph 3-7.
5. Hose (3)	Install onto items (4) and (8).	



TRANSMISSION.

**3-141. LINES AND FITTINGS REPLACEMENT (Continued)**

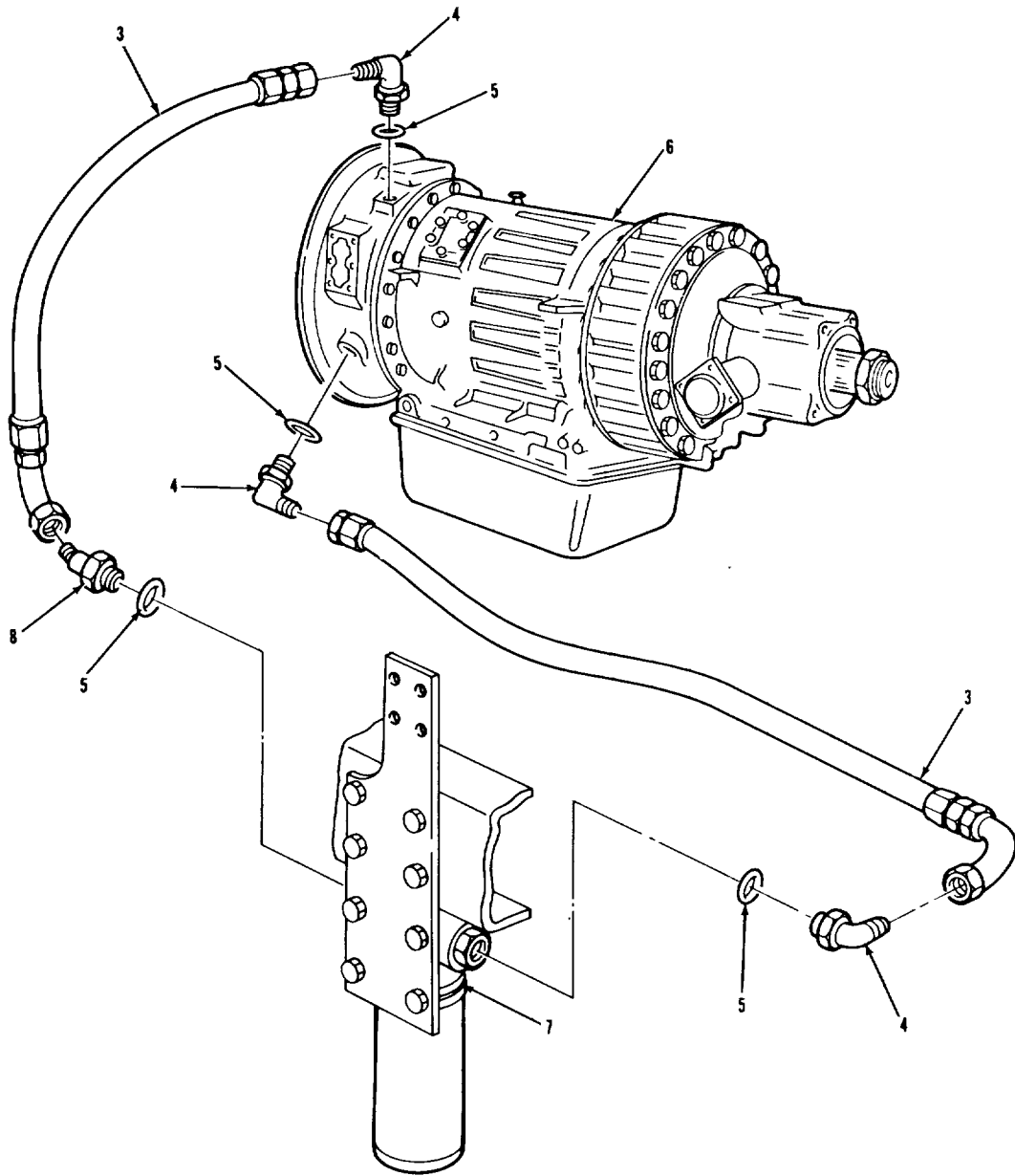

LEGEND:

- 3. TRANSMISSION TO FILTER HOSE ASSEMBLY (2)
- 4. 90 DEGREE ELBOW (3)
- 5. O-RING (4)

- 6. TRANSMISSION ASSEMBLY
- 7. OIL FILTER BASE
- 8. 45 DEGREE ELBOW

TA 237397

**TRANSMISSION.**

<b>3-141. LINES AND FITTINGS REPLACEMENT (Continued).</b>		
<b>LOCATION/ITEM</b>	<b>ACTION</b>	<b>REMARKS</b>
<b><u>B. OIL COOLER LINES AND FITTINGS REPLACEMENT. I</u></b>		
6. Two ties (22)	Cut off of items (1) and (2). Discard items (22).	
7. Four screws (14), nuts (9), and eight clamps (13).	Remove from items (10), (15), (21), (24), (1), and (2).	
8. Hose (2) and pull out from under	Remove from two items (4), tainer ready to catch vehicle	Have a suitable container ready to catch any oil from item (2).
9. Two elbows (4) and O-rings (5)	Remove from items (6) and (25).	Discard items (5).
10. Hose (1)	Remove from items (4) and (23), and pull out from under vehicle	Have a suitable container ready to catch any oil from item (1).
11. Elbow (4) and O-ring (5).	Remove from item (6)	Discard item (5).
12. Union (23)	Remove from item (26).	
13. Screw (12), lock-washer (11), and support (10).	Remove from item (6).	
14. Two bolts (17), washers (16), and bracket (15).	Remove from item (18).	
15. Screws (20) and bracket (21).	Remove from item (19).	

TRANSMISSION.

3-141. LINES AND FITTINGS REPLACEMENT (Continued).

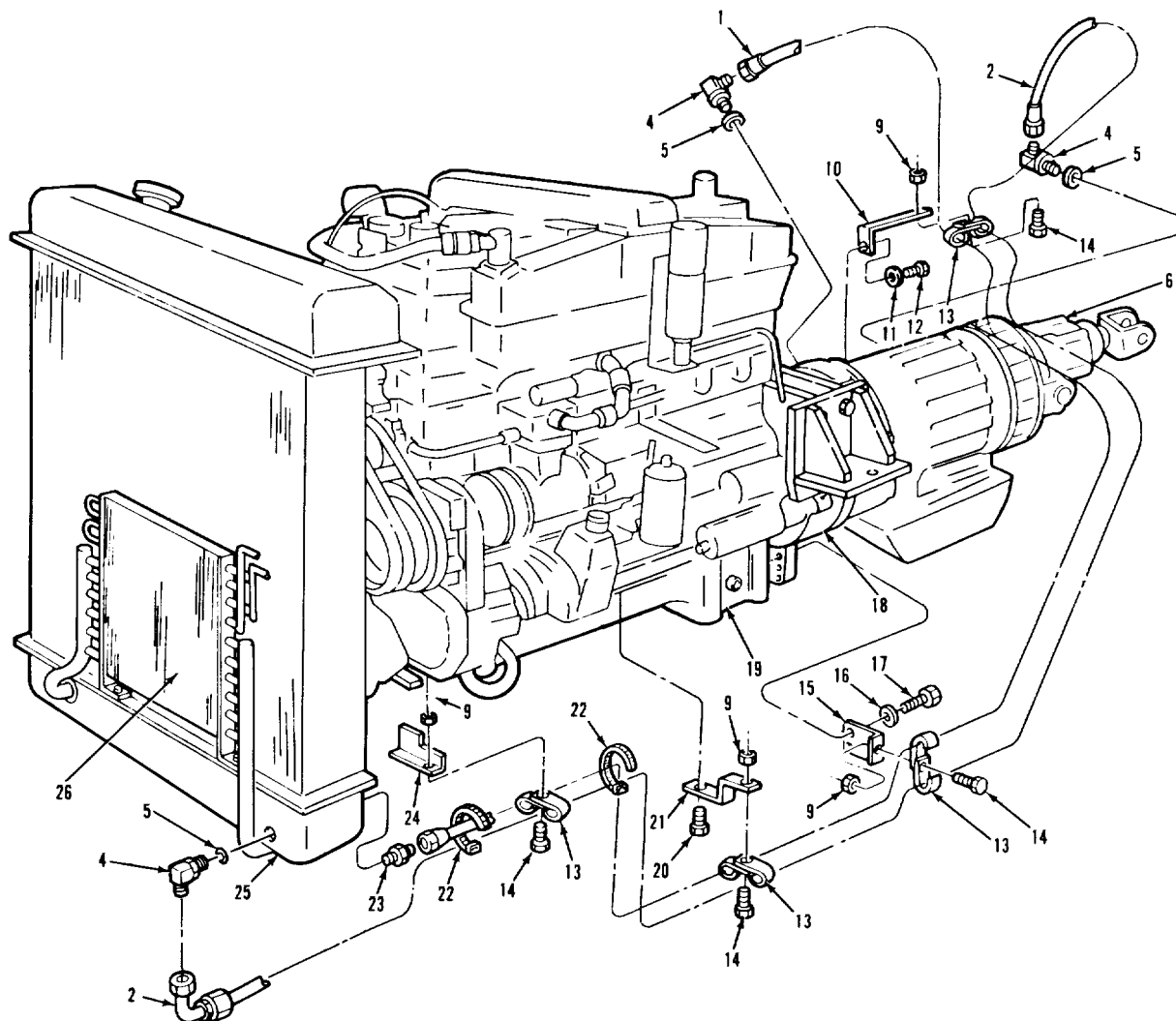

LEGEND:

- |                                |                                |
|--------------------------------|--------------------------------|
| 1. COOLER RETURN HOSE ASSEMBLY | 16. LOCKWASHER (2)             |
| 2. COOLER SUPPLY HOSE ASSEMBLY | 17. HEXAGON BOLT (2)           |
| 4. 90 DEGREE ELBOW (3)         | 18. FLYWHEEL HOUSING           |
| 5. O-RING (4)                  | 19. OIL PAN                    |
| 6. TRANSMISSION ASSEMBLY       | 20. CAPTIVE WASHER SCREW       |
| 9. HEXAGON HEAD NUT (4)        | 21. COOLER HOSE BRACKET        |
| 10. COOLER HOSE SUPPORT        | 22. CABLE TIE                  |
| 11. LOCKWASHER                 | 23. 37 DEGREE FLARE UNION      |
| 12. HEXAGON HEAD SCREW         | 24. FRONT CROSSMEMBER ASSEMBLY |
| 13. HOSE CLAMP (8)             | 25. RADIATOR ASSEMBLY          |
| 14. HEXAGON BOLT (4)           | 26. OIL COOLER                 |
| 15. COOLER HOSE BRACKET        |                                |

TA 237398

**TRANSMISSION.**

<b>3-141. LINES AND FITTINGS REPLACEMENT (Continued).</b>		
<b>LOCATION/ITEM</b>	<b>ACTION</b>	<b>REMARKS</b>
<b>B. OIL COOLER LINES AND FITTINGS REPLACEMENT (Continued). I</b>		
16. All parts	Clean and inspect	Refer to paragraphs 3-4 and 3-5.
17. Bracket (21)	a. Position on item (19). b. Secure with item (20).	
18. Bracket (15)	a. Position on item (18). b. Secure with two items (16) and (17).	
19. Support (10)	a. Position on item (6). b. Secure with items (11) and (12).	
20. Union (23)	a. Wrap threads with thread sealing tape.	Refer to paragraph 3-7.
b. Install into item (26).		
21. Elbow (4) and new O-ring (5)	a. Wrap threads of item (4) with thread sealing tape. b. Coat item (5) with clean lubricating oil. c. Install into item (6).	Refer to paragraph 3-7.
22. Hose (1)	Put in place under vehicle and install onto items (4) and (23).	
23. Two elbows (4) and new O-rings (5)	a. Wrap threads of item (4) with thread sealing tape.	Refer to paragraph 3-7.
<b>3-852</b>		

TRANSMISSION.

3-141. LINES AND FITTINGS REPLACEMENT (Continued).

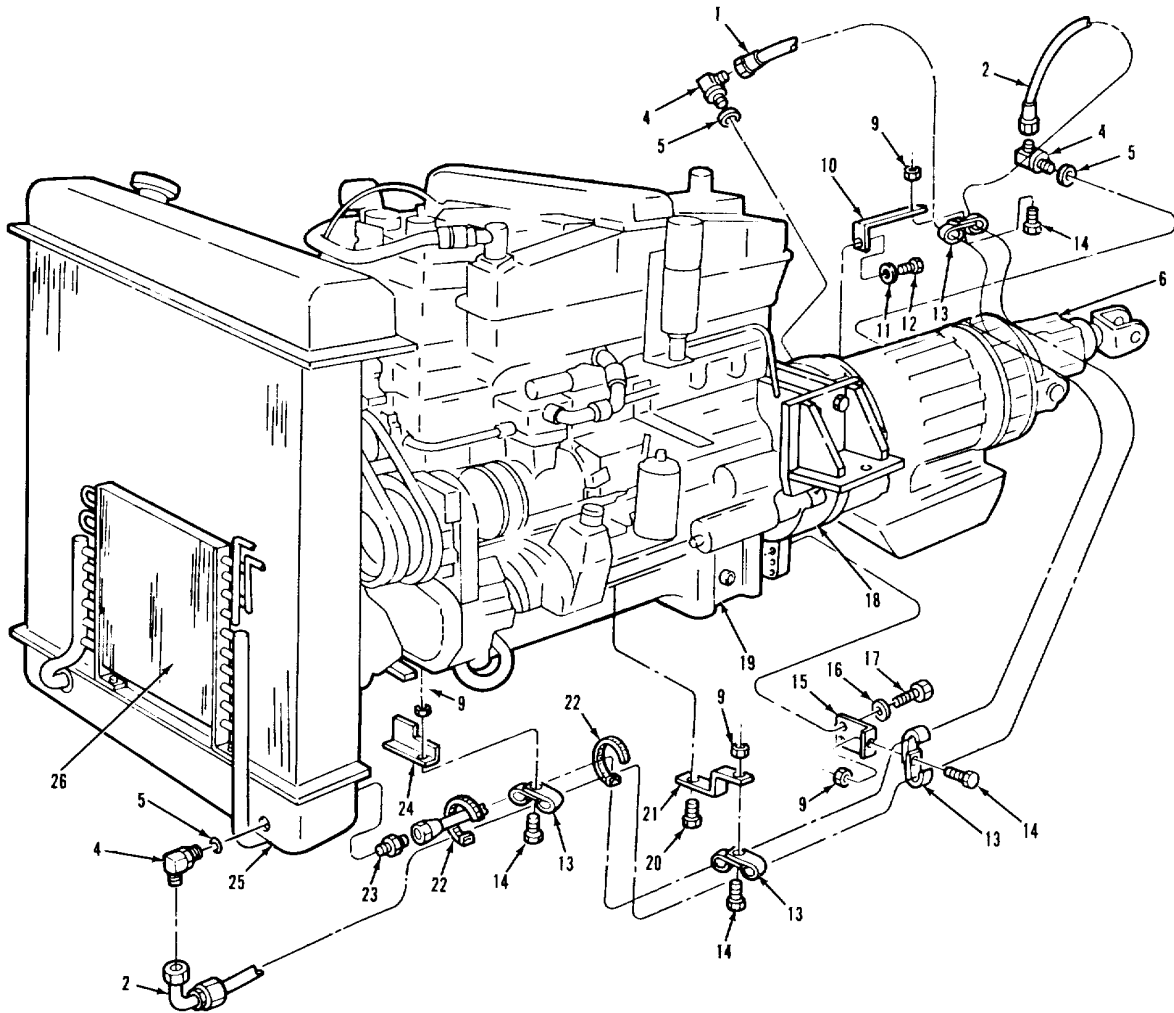

LEGEND:

- |                                |                                |
|--------------------------------|--------------------------------|
| 1. COOLER RETURN HOSE ASSEMBLY | 16. LOCKWASHER (2)             |
| 2. COOLER SUPPLY HOSE ASSEMBLY | 17. HEXAGON BOLT (2)           |
| 4. 90 DEGREE ELBOW (3)         | 18. FLYWHEEL HOUSING           |
| 5. O-RING (4)                  | 19. OIL PAN                    |
| 6. TRANSMISSION ASSEMBLY       | 20. CAPTIVE WASHER SCREW       |
| 9. HEXAGON HEAD NUT (4)        | 21. COOLER HOSE BRACKET        |
| 10. COOLER HOSE SUPPORT        | 22. CABLE TIE                  |
| 11. LOCKWASHER                 | 23. 37 DEGREE FLARE UNION      |
| 12. HEXAGON HEAD SCREW         | 24. FRONT CROSSMEMBER ASSEMBLY |
| 13. HOSE CLAMP (8)             | 25. RADIATOR ASSEMBLY          |
| 14. HEXAGON BOLT (4)           | 26. OIL COOLER                 |
| 15. COOLER HOSE BRACKET        |                                |

TA 237399

**TRANSMISSION.**

3-141. LINES AND FITTINGS REPLACEMENT (Continued).		
LOCATION/ITEM	ACTION	REMARKS
<b>B. OIL COOLER LINES AND FITTINGS REPLACEMENT (Continued).</b>		
23. Two elbows (4) and new O-rings (5) (continued).	b. Coat item (5) with clean lubricating oil.  c. Install into items (6) and (25).	
24. Hose (2)	Put in place under vehicle and install onto two items (4).	
25. Eight clamps (13)	a. Position in pairs on items (1) and (2). b. Secure one pair to each item (10), (15), (21), and (24) using items (14) and (9).	
26. Two new ties (22).	Install on items (1) and (2).	
<b>NOTE</b>		
<b>Follow-on maintenance action required:</b>		
Check transmission oil level and fill if necessary (TM 9-2320-283-10).		

TRANSMISSION.

3-141. LINES AND FITTINGS REPLACEMENT (Continued).

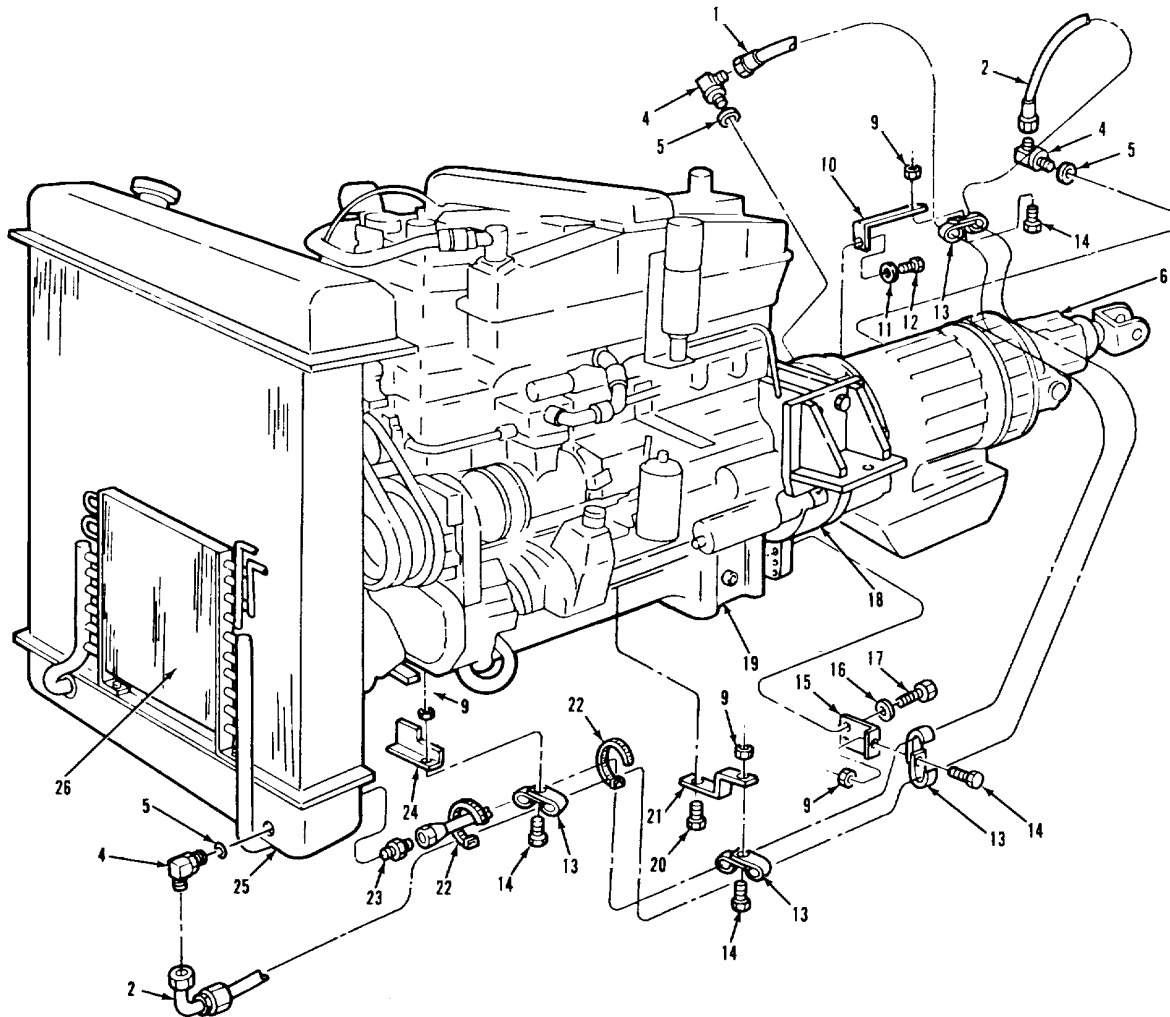

LEGEND:

- |                                |                                |
|--------------------------------|--------------------------------|
| 1. COOLER RETURN HOSE ASSEMBLY | 16. LOCKWASHER (2)             |
| 2. COOLER SUPPLY HOSE ASSEMBLY | 17. HEXAGON BOLT (2)           |
| 4. 90 DEGREE ELBOW (3)         | 18. FLYWHEEL HOUSING           |
| 5. O-RING (4)                  | 19. OIL PAN                    |
| 6. TRANSMISSION ASSEMBLY       | 20. CAPTIVE WASHER SCREW       |
| 9. HEXAGON HEAD NUT (4)        | 21. COOLER HOSE BRACKET        |
| 10. COOLER HOSE SUPPORT        | 22. CABLE TIE                  |
| 11. LOCKWASHER                 | 23. 37 DEGREE FLARE UNION      |
| 12. HEXAGON HEAD SCREW         | 24. FRONT CROSSMEMBER ASSEMBLY |
| 13. HOSE CLAMP (8)             | 25. RADIATOR ASSEMBLY          |
| 14. HEXAGON BOLT (4)           | 26. OIL COOLER                 |
| 15. COOLER HOSE BRACKET        |                                |

TA 237400

**Section VIII. PROPELLER SHAFTS AND UNIVERSAL JOINTS**

**3-142. GENERAL.**

This section provides procedures authorized at the organizational maintenance level to replace primary and interaxle propeller shaft components. To find a specific procedure contained in this section, see the task summary below.

<b>3-143. TASK SUMMARY.</b>		
<b>INITIAL SETUP</b>		
<u>APPLICABLE CONFIGURATIONS</u>	<u>EQUIPMENT CONDITION PARAGRAPH</u>	<u>CONDITION DESCRIPTION</u>
All	(Refer to specific paragraph for this information).	
<u>TEST EQUIPMENT</u>		
None.		
<u>SPECIAL TOOLS</u>		
None.		
<u>MATERIALS/PARTS (P/N)</u>		
Grease, automotive and artillery Item 7, Appendix C.		
<u>PERSONNEL REQUIRED</u>	<u>SPECIAL ENVIRONMENTAL CONDITIONS</u>	
One (MOS-63S)	None.	
<u>REFERENCES (TM)</u>	<u>GENERAL SAFETY INSTRUCTIONS</u>	
LO 9-2320-283-12 TM 9-2320-283-10	Engine off. Transmission in neutral. Park brake set.	
<u>TROUBLESHOOTING REFERENCES</u>		
Paragraph 2-11.		



**PROPELLER SHAFTS AND UNIVERSAL JOINTS.****3-143. TASK SUMMARY (Continued).****LIST OF TASKS**

<b>TASK NO</b>	<b>TASK</b>	<b>TASK REF</b>	<b>TROUBLESHOOTING REF NO. (PARA)</b>
1	Primary Propeller Shaft and Universal Joints Replacement	3-144	2-11
	a. Primary Shaft Assembly Replacement	3-144a	
	b. Universal Joint Replacement	3-144b	
2	Interaxle Propeller Shaft and Universal Joints Replacement	3-145	2-11
	a. Interaxle Shaft Assembly Replacement	3-145a	
	b. Universal Joint Replacement	3-145b	

**PROPELLER SHAFTS AND UNIVERSAL JOINTS.**

<b>3-144. PRIMARY PROPELLER SHAFT AND UNIVERSAL JOINTS REPLACEMENT</b>		
<b><u>THIS TASK COVERS</u></b>		
a. Primary Shaft Assembly Replacement. b. Universal Joint Replacement		
<b>INITIAL SETUP</b>		
<u>APPLICABLE CONFIGURATIONS</u>	<u>EQUIPMENT CONDITION PARAGRAPH</u>	<u>CONDITION DESCRIPTION</u>
All.	None.	None.
<u>TEST EQUIPMENT</u>		
None.		
<u>SPECIAL TOOLS</u>		
None.		
<u>MATERIALS/PARTS (P/N)</u>		
Grease, automotive and artillery Item 7, Appendix C.		
<u>PERSONNEL REQUIRED</u>	<u>SPECIAL ENVIRONMENTAL CONDITIONS</u>	
One (MOS-63S).	None.	
<u>REFERENCES (TM)</u>	<u>GENERAL SAFETY INSTRUCTIONS</u>	
LO 9-2320-283-12. TM 9-2320-283-10.	Engine off. Transmission in neutral. Park brake set.	
<u>TROUBLESHOOTING REFERENCES</u>		
Paragraph 2-11.		

PROPELLER SHAFTS AND UNIVERSAL JOINTS.

3-144. PRIMARY PROPELLER SHAFT AND UNIVERSAL JOINTS REPLACEMENT (Continued).

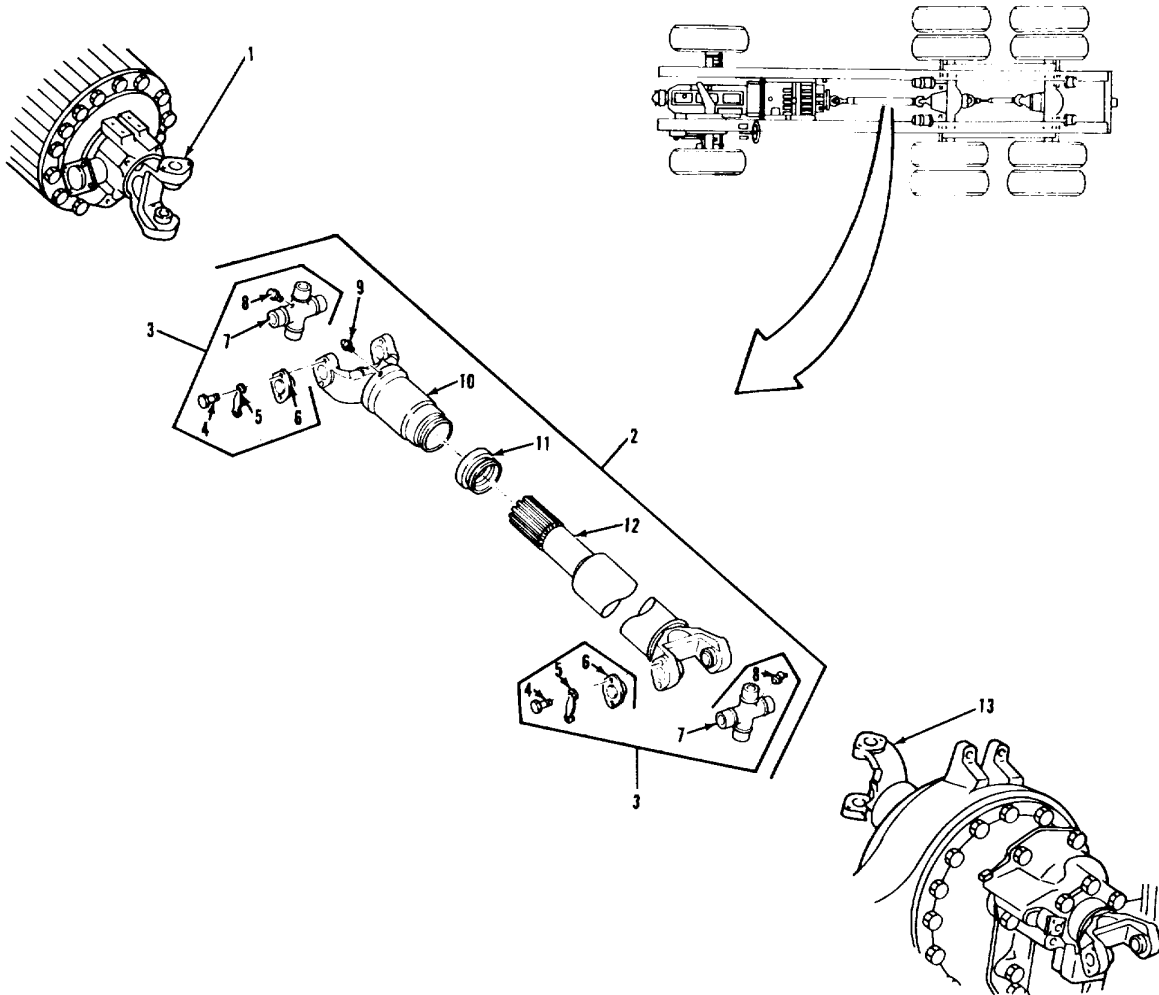

LEGEND:

- |                             |                            |
|-----------------------------|----------------------------|
| 1. TRANSMISSION OUTPUT YOKE | 8. LUBRICATION FITTING (2) |
| 2. PRIMARY SHAFT ASSEMBLY   | 9. LUBRICATION FITTING     |
| 3. UNIVERSAL JOINT (2)      | 10. SLIP YOKE              |
| 4. CAPSCREW (16)            | 11. DUST SEAL              |
| 5. LOCK PLATE (8)           | 12. SPLINED SHAFT          |
| 6. BEARING CUP ASSEMBLY (8) | 13. YOKE                   |
| 7. CENTER CROSS (2)         |                            |

TA 237401

**PROPELLER SHAFTS AND UNIVERSAL JOINTS.**

<b>3-144. PRIMARY PROPELLER SHAFT AND UNIVERSAL JOINTS REPLACEMENT (Continued).</b>		
<b>LOCATION/ITEM</b>	<b>ACTION</b>	<b>REMARKS</b>
<b>A. PRIMARY SHAFT ASSEMBLY REPLACEMENT.</b>		
<b>NOTE</b>		
<b>It may be necessary to jack up rear differential with park brake off to release torque pressure on propeller shaft/universal joint connections.</b>		
1. Shaft assembly (2).	Support with suitable jack or sling.	
2. Eight plates (5)	Bend down tabs.	
3. Sixteen capscrews (4) and eight plates (5).	Remove from eight items (6).	
4. Eight bearing cups (6)	Remove from items (1) and (13).	
5. Shaft assembly (2)	Rotate two items (7) out of items (1) and (13), and remove item (2) from under vehicle.	
6. All parts	Clean and inspect	Refer to paragraphs 3-4 and 3-5. If item (11) is damaged, do steps 7 thru 10.
7. Seal (11)	Unscrew from item (10).	
<b>3-860</b>		

PROPELLER SHAFTS AND UNIVERSAL JOINTS.

3-144. PRIMARY PROPELLER SHAFT AND UNIVERSAL JOINTS REPLACEMENT (Continued).

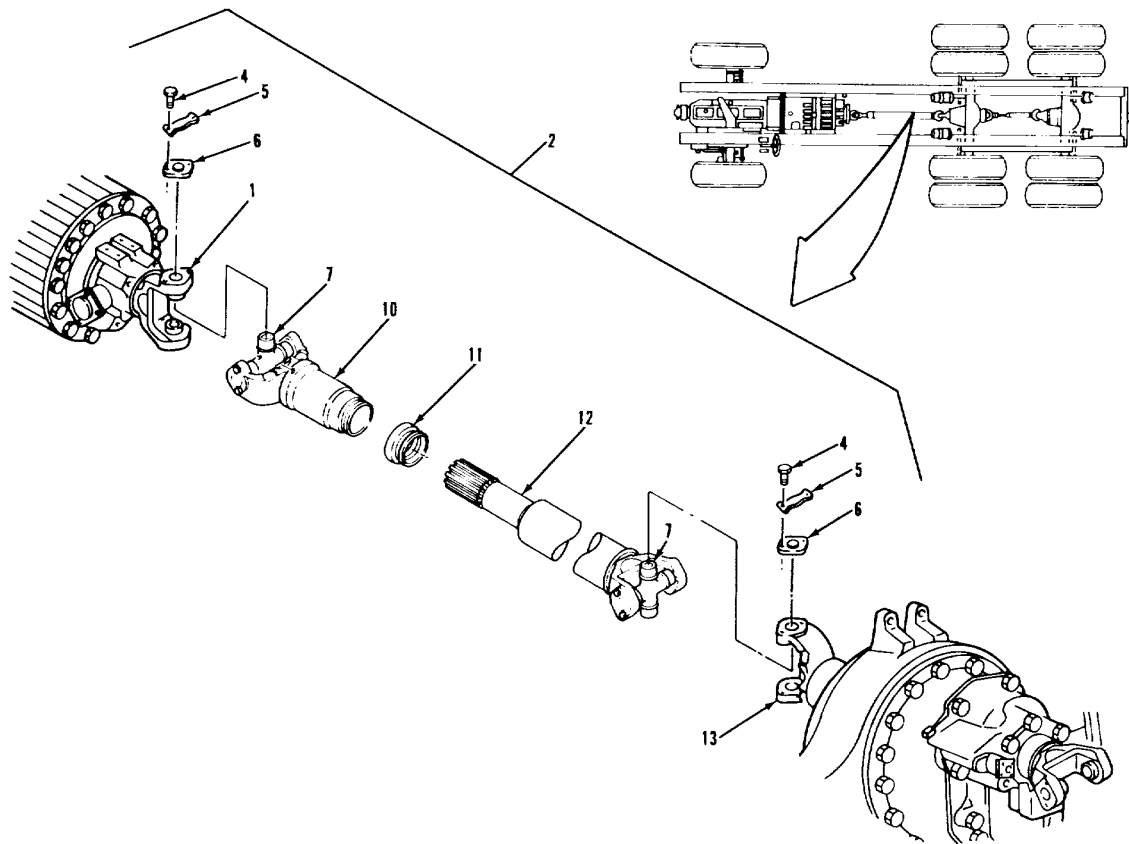

LEGEND:

- |                             |                     |
|-----------------------------|---------------------|
| 1. TRANSMISSION OUTPUT YOKE | 7. CENTER CROSS (2) |
| 2. PRIMARY SHAFT ASSEMBLY   | 10. SLIP YOKE       |
| 4. CAPSCREW (16)            | 11. DUST SEAL       |
| 5. LOCK PLATE (8)           | 12. SPLINED SHAFT   |
| 6. BEARING CUP ASSEMBLY (8) | 13. YOKE            |

TA 237402

**PROPELLER SHAFTS AND UNIVERSAL JOINTS.**

<b>3-144. PRIMARY PROPELLER SHAFT AND UNIVERSAL JOINTS REPLACEMENT (Continued).</b>		
<b>LOCATION/ITEM</b>	<b>ACTION</b>	<b>REMARKS</b>
<b>A. PRIMARY SHAFT ASSEMBLY REPLACEMENT (Continued)</b>		
8. Yoke (10) and shaft (12)	<ul style="list-style-type: none"> <li>a. Put an alignment mark on each, if not already done.</li> <li>b. Pull item (12) out of item (10).</li> <li>c. Remove item (11) from item (12).</li> </ul>	Discard item (11).
9. New seal (11)	Lubricate with grease and install on item (12).	
10. Yoke (10) and shaft (12)	<ul style="list-style-type: none"> <li>a. Push item (12) into item (10).</li> <li>b. Screw item (11) onto item (10)</li> </ul>	Be careful not to damage threads of item (11).
11. Shaft assembly (2)	<ul style="list-style-type: none"> <li>a. Using suitable jack or sling, put in place under vehicle.</li> <li>b. Install two items (7) into items (1) and (13).</li> </ul>	
12. Eight bearing cups (6)	Coat with grease and press into items (1) and (13) to secure two items (7)	If items (6) will not slide onto item (7), remove item (6) and check if any needle bearing have slipped out of position.
13. Eight plates (5)	<ul style="list-style-type: none"> <li>a. Position on eight items (6).</li> <li>b. Secure with sixteen items (4).</li> <li>c. Bend up tabs to lock items (4) in place.</li> </ul>	

PROPELLER SHAFTS AND UNIVERSAL JOINTS.

3-144. PRIMARY PROPELLER SHAFT AND UNIVERSAL JOINTS REPLACEMENT (Continued).

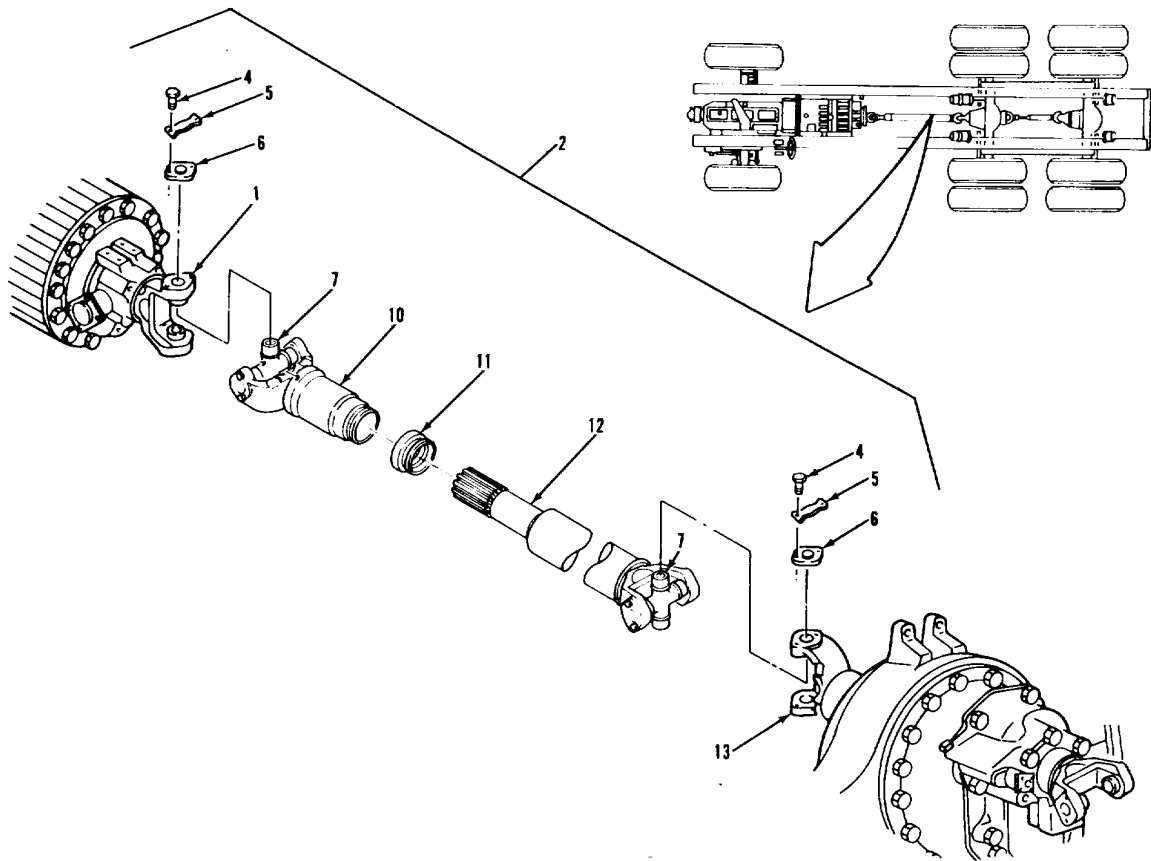

LEGEND:

- |                             |                     |
|-----------------------------|---------------------|
| 1. TRANSMISSION OUTPUT YOKE | 7. CENTER CROSS (2) |
| 2. PRIMARY SHAFT ASSEMBLY   | 10. SLIP YOKE       |
| 4. CAPSCREW (16)            | 11. DUST SEAL       |
| 5. LOCK PLATE (8)           | 12. SPLINED SHAFT   |
| 6. BEARING CUP ASSEMBLY (8) | 13. YOKE            |

TA 237403

**PROPELLER SHAFTS AND UNIVERSAL JOINTS.**

<b>3-144. PRIMARY PROPELLER SHAFT AND UNIVERSAL JOINTS REPLACEMENT (Continued).</b>		
<b>LOCATION/ITEM</b>	<b>ACTION</b>	<b>REMARKS</b>
<b>B. UNIVERSAL JOINT REPLACEMENT.</b>		
<b>NOTE</b>		
<b>There are two universal joints on the primary shaft assembly. Both are shown in the illustration, but only one is covered in the text. Follow this procedure to replace either universal joint.</b>		
14. Shaft assembly (2)	Support with suitable jack or sling.	
15. Four plates (5)	Bend down tabs.	
16. Eight screws (4) and four plates (5).	Remove from four items (6).	
17. Four bearing cups (6)	Remove from items (1) and (10), or items (12) and (13).	
18. Cross (7)	Rotate out of items (1) and (10), or items (12) and (13).	
19. All parts	Clean and inspect	Refer to paragraphs 3-4 and 3-5.
20. Cross (7)	Rotate into items (1) and (10), or items (12) and (13).	
21. Four bearing cups (6)	Coat with grease and press into items (1) and (10), or items (12) and (13) to secure item (7)	If item (6) will not slide onto item (7), remove item (6) and check if any needle bearings have slipped out of position.



PROPELLER SHAFTS AND UNIVERSAL JOINTS.

3-144. PRIMARY PROPELLER SHAFT AND UNIVERSAL JOINTS REPLACEMENT (Continued).

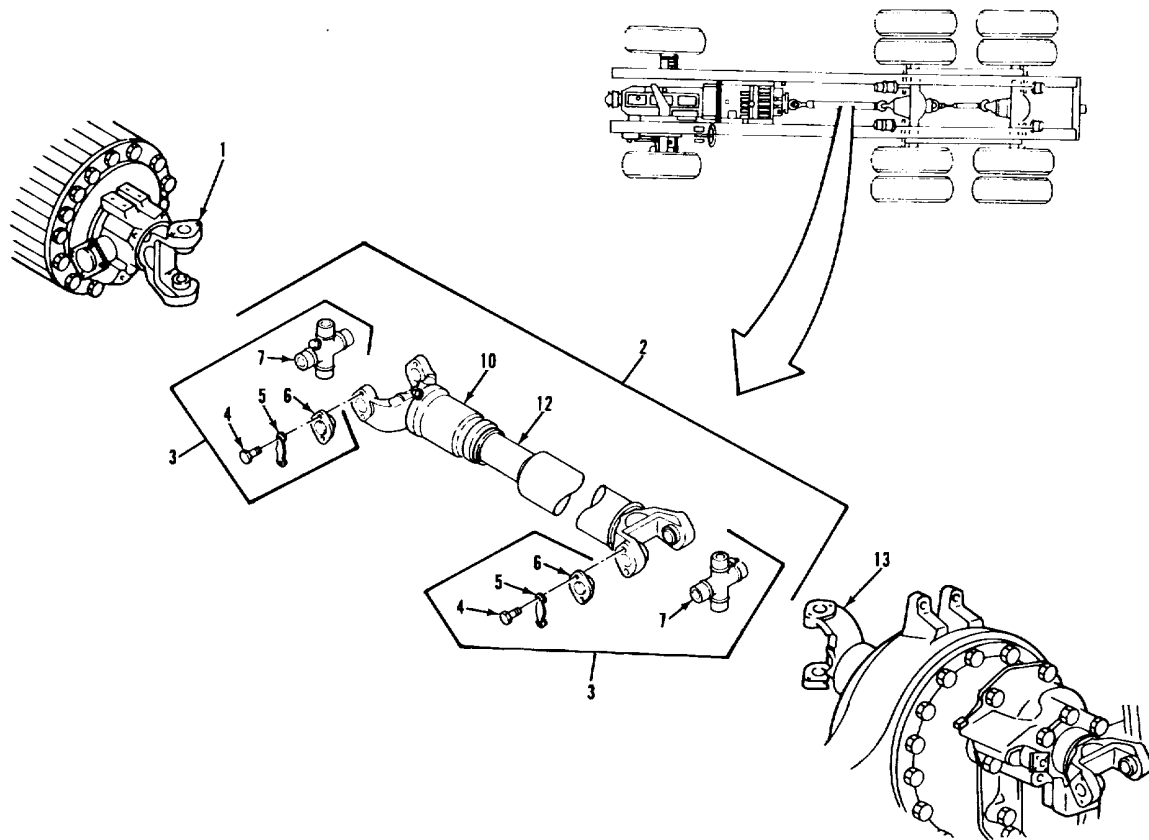

LEGEND:

- |                             |                             |
|-----------------------------|-----------------------------|
| 1. TRANSMISSION OUTPUT YOKE | 6. BEARING CUP ASSEMBLY (8) |
| 2. PRIMARY SHAFT ASSEMBLY   | 7. CENTER CROSS (2)         |
| 3. UNIVERSAL JOINT (2)      | 10. SLIP YOKE               |
| 4. CAPSCREW (16)            | 12. SPLINED SHAFT           |
| 5. LOCK PLATE (8)           | 13. YOKE                    |

TA 237404

**PROPELLER SHAFTS AND UNIVERSAL JOINTS.**

<b>3-144. PRIMARY PROPELLER SHAFT AND UNIVERSAL JOINTS REPLACEMENT (Continued).</b>		
<b>LOCATION/ITEM</b>	<b>ACTION</b>	<b>REMARKS</b>
<b>B. UNIVERSAL JOINT REPLACEMENT (Continued).</b>		
22. Four plates (5)	a. Position on four items (6). b. Secure with eight items (4). c. Bend up tabs to lock items (4) in place.	
<b>NOTE</b>		
<b>Follow-on maintenance action required:</b>		
Apply grease to all fittings on primary shaft (LO 9-2320-283-12). Road test and check for unusual noise or vibration (TM 9-2320-283-10).		

PROPELLER SHAFTS AND UNIVERSAL JOINTS.

3-144. PRIMARY PROPELLER SHAFT AND UNIVERSAL JOINTS REPLACEMENT (Continued).

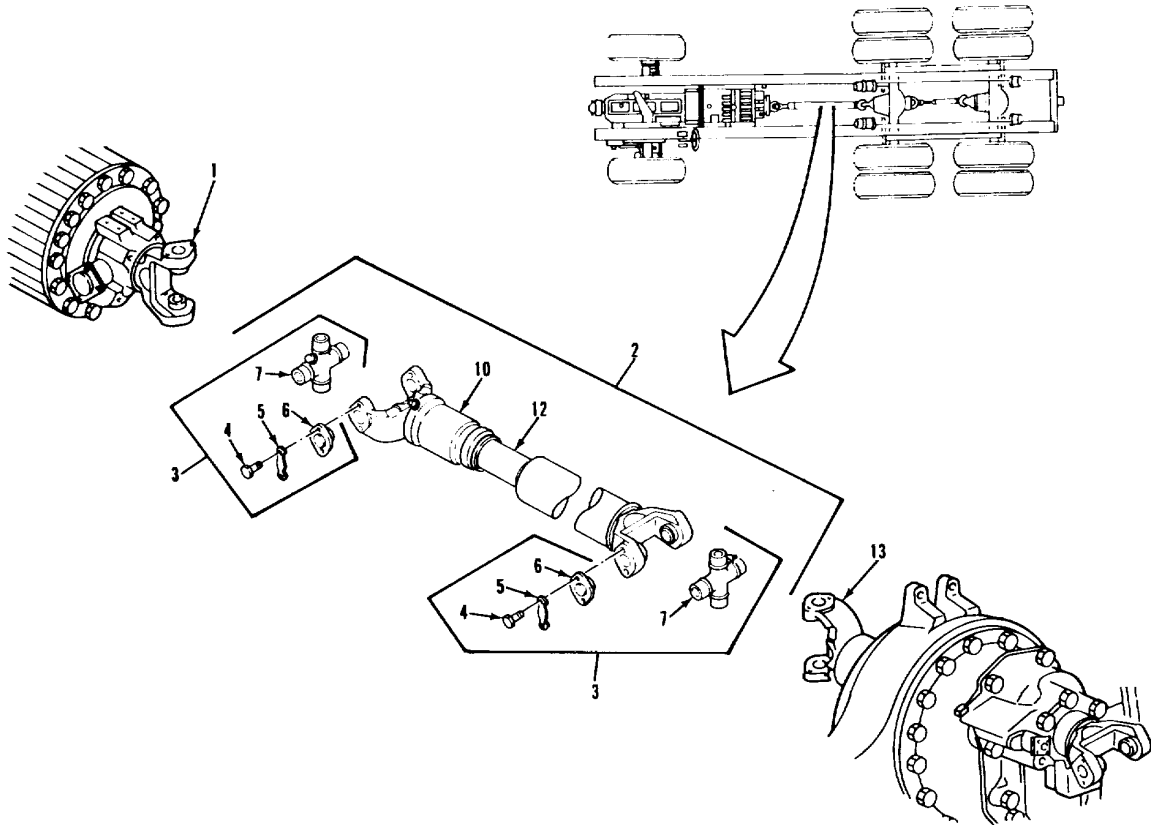

LEGEND:

- |                             |                             |
|-----------------------------|-----------------------------|
| 1. TRANSMISSION OUTPUT YOKE | 6. BEARING CUP ASSEMBLY (8) |
| 2. PRIMARY SHAFT ASSEMBLY   | 7. CENTER CROSS (2)         |
| 3. UNIVERSAL JOINT (2)      | 10. SLIP YOKE               |
| 4. CAPSCREW (16)            | 12. SPLINED SHAFT           |
| 5. LOCK PLATE (8)           | 13. YOKE                    |

TA 237405

**PROPELLER SHAFTS AND UNIVERSAL JOINTS.**

<b>3-145. INTERAXLE PROPELLER SHAFT AND UNIVERSAL JOINTS REPLACEMENT.</b>		
<u>THIS TASK COVERS</u>		
<ul style="list-style-type: none"> <li>a. Interaxle Shaft Assembly Replacement.</li> <li>b. Universal Joint Replacement.</li> </ul>		
<u>INITIAL SETUP</u>		
<u>APPLICABLE CONFIGURATIONS</u>	<u>EQUIPMENT CONDITION PARAGRAPH</u>	<u>CONDITION DESCRIPTION</u>
All None	None.	
<u>TEST EQUIPMENT</u>		
None.		
<u>SPECIAL TOOLS</u>		
None.		
<u>MATERIALS/PARTS (P/N)</u>		
Grease, automotive and artillery Item 7, Appendix C.		
<u>PERSONNEL REQUIRED</u>	<u>SPECIAL ENVIRONMENTAL CONDITIONS</u>	
One (MOS-63S)	None.	
<u>REFERENCES (TM)</u>	<u>GENERAL SAFETY INSTRUCTIONS</u>	
LO 9-2320-283-12 TM 9-2320-283-10	Engine off. Transmission in neutral. Park brake set.	
<u>TROUBLESHOOTING REFERENCES</u>		
Paragraph 2-11.		

PROPELLER SHAFTS AND UNIVERSAL JOINTS.

3-145. INTERAXLE PROPELLER SHAFT AND UNIVERSAL JOINTS REPLACEMENT (Continued).

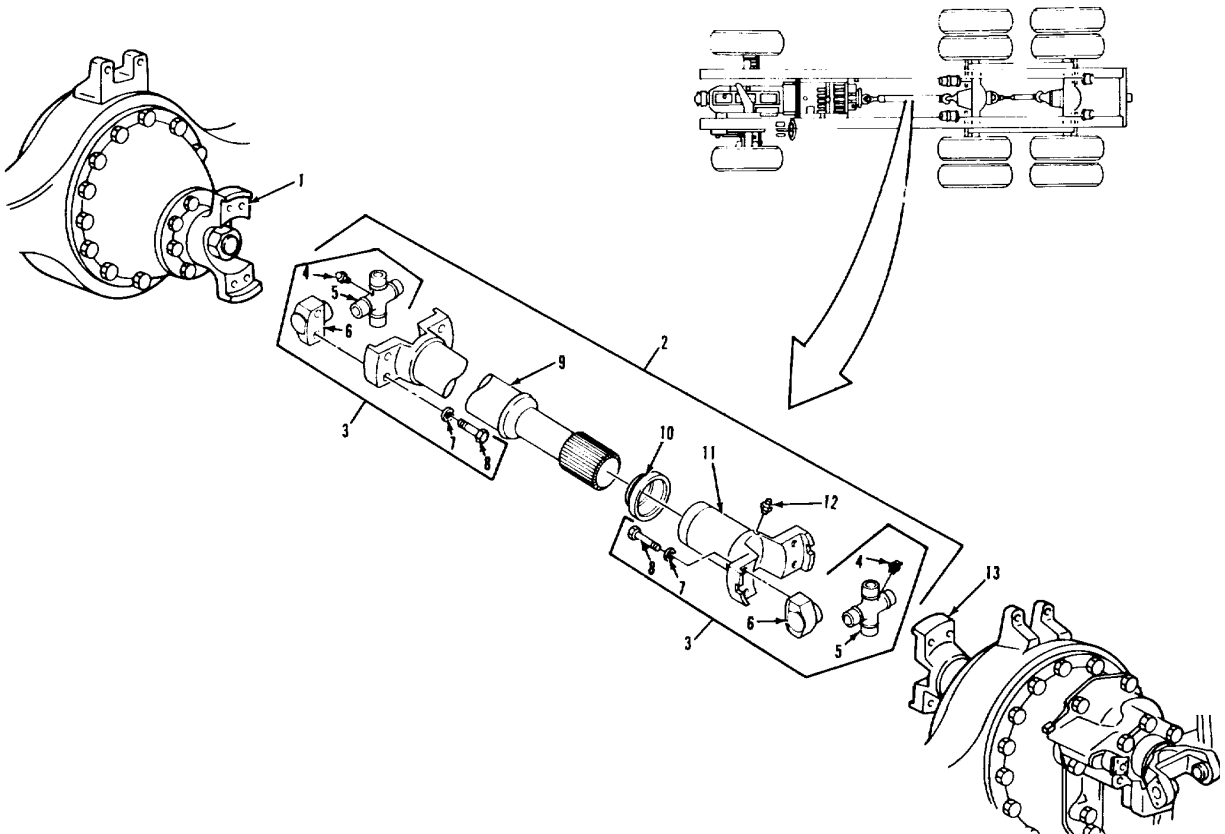

LEGEND:

- |                             |                           |
|-----------------------------|---------------------------|
| 1. OUTPUT SHAFT FLANGE      | 8. CAPSCREW (16)          |
| 2. INTERAXLE SHAFT ASSEMBLY | 9. SPLINED SHAFT          |
| 3. UNIVERSAL JOINT (2)      | 10. DUST SEAL             |
| 4. LUBRICATION FITTING (2)  | 11. SLIP FLANGE           |
| 5. CENTER CROSS (2)         | 12. LUBRICATION FITTING   |
| 6. BEARING CUP ASSEMBLY (8) | 13. INPUT FLANGE ASSEMBLY |
| 7. LOCKWASHER (16)          |                           |

TA 237406

**PROPELLER SHAFTS AND UNIVERSAL JOINTS.**

<b>3-145. INTERAXLE PROPELLER SHAFT AND UNIVERSAL JOINTS REPLACEMENT (Continued).</b>		
<b>LOCATION/ITEM</b>	<b>ACTION</b>	<b>REMARKS</b>
<b>A. INTERAXLE SHAFT ASSEMBLY REPLACEMENT.</b>		
<b>NOTE</b>		
<b>It may be necessary to jack up rear differential with park brake off to release torque pressure on propeller shaft/universal joint connections.</b>		
1. Shaft assembly (2).	Support with suitable jack or sling.	
2. Eight screws (8) and lockwashers (7).	Remove from items (1), (13), and four items (6)	Leave items (6) on items (5).
3. Shaft assembly (2)	Remove from under vehicle.	
4. All parts	Clean and inspect	Refer to paragraphs 3-4 and 3-5. If item (10) is damaged, do steps 5 thru 8.
5. Seal (10)	Unscrew from item (11).	
6. Flange (11) and shaft (9)	a. Put an alignment mark on each, if not already done. b. Pull item (9) out of item (11). c. Remove item (10) from item (9). Discard item (10).	
7. New seal (10)	Lubricate with grease and install on item (9).	

PROPELLER SHAFTS AND UNIVERSAL JOINTS.

3-145. INTERAXLE PROPELLER SHAFT AND UNIVERSAL JOINTS REPLACEMENT (Continued).

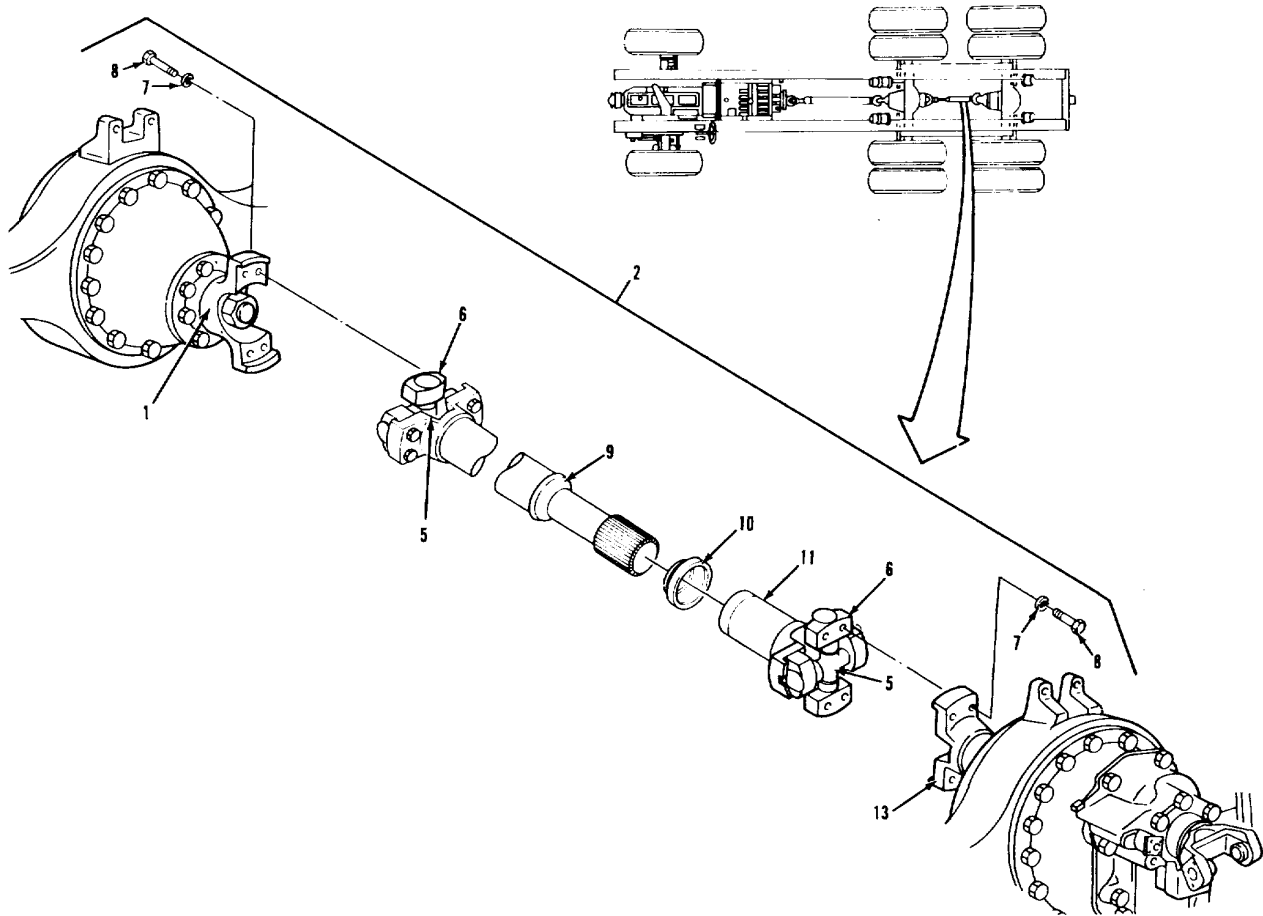

LEGEND:

- 1. OUTPUT SHAFT FLANGE
- 2. INTERAXLE SHAFT ASSEMBLY
- 5. CENTER CROSS (2)
- 6. BEARING CUP ASSEMBLY (4)
- 7. LOCKWASHER (8)

- 8. CAPSCREW (8)
- 9. SPLINED SHAFT
- 10. DUST SEAL
- 11. SLIP FLANGE
- 13. INPUT FLANGE ASSEMBLY

TA 237407

**PROPELLER SHAFTS AND UNIVERSAL JOINTS.**

<b>3-145. INTERAXLE PROPELLER SHAFT AND UNIVERSAL JOINTS REPLACEMENT (Continued).</b>		
<b>LOCATION/ITEM</b>	<b>ACTION</b>	<b>REMARKS</b>
<b>A. INTERAXLE SHAFT ASSEMBLY REPLACEMENT (Continued).</b>		
8. Flange (11) and shaft (9)	a. Push item (9) into item (11). b. Screw item (10) onto item (11)	Be careful not to damage threads of item (10).
9. Shaft assembly (2)	a. Using suitable jack or sling, put in place under vehicle. b. Line up holes in four items (6) with holes in items (1) and (13). c. Secure with eight items (8) and (7)	Torque items (8) to 100-110 lb-ft.
<b>B. UNIVERSAL JOINT REPLACEMENT.</b>		
<b>NOTE</b>		
There are two universal joints on the interaxle shaft assembly Both are shown in the illustration, but only one is covered in the text Follow this procedure to replace either universal joint.		
10. Shaft assembly (2)	Support with suitable jack or sling.	



PROPELLER SHAFTS AND UNIVERSAL JOINTS.

3-145. INTERAXLE PROPELLER SHAFT AND UNIVERSAL JOINTS REPLACEMENT (Continued).

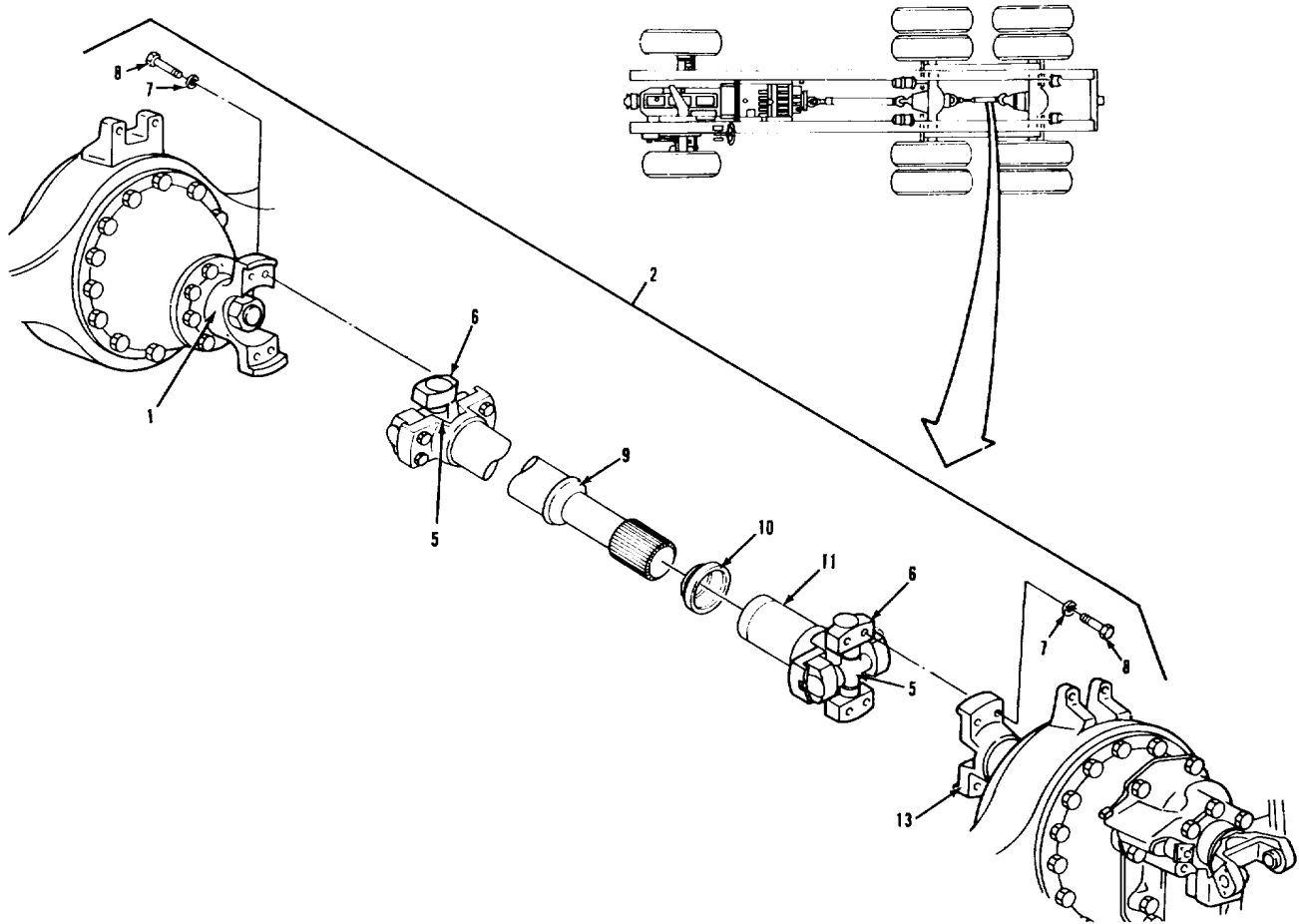

LEGEND:

- |                             |                           |
|-----------------------------|---------------------------|
| 1. OUTPUT SHAFT FLANGE      | 8. CAPSCREW (8)           |
| 2. INTERAXLE SHAFT ASSEMBLY | 9. SPLINED SHAFT          |
| 5. CENTER CROSS (2)         | 10. DUST SEAL             |
| 6. BEARING CUP ASSEMBLY (4) | 11. SLIP FLANGE           |
| 7. LOCKWASHER (8)           | 13. INPUT FLANGE ASSEMBLY |

TA 237408

**PROPELLER SHAFTS AND UNIVERSAL JOINTS.**

<b>3-145. INTERAXLE PROPELLER SHAFT AND UNIVERSAL JOINTS REPLACEMENT (Continued).</b>		
<b>LOCATION/ITEM</b>	<b>ACTION</b>	<b>REMARKS</b>
<b>B. UNIVERSAL JOINT REPLACEMENT (Continued).</b>		
11. Eight screws (8) and lockwashers (7).	Remove from items (9), (6), and (1).	
12. Cross (5) and four bearing cups (6)	Remove from items (9) and (1), and separate.	
13. All parts and 3-5.	Clean and inspect	Refer to paragraphs 3-4
14. Cross (5) and four bearing cups (6)	a. Assemble and position on items (9) and (1).	Use grease on items (6).
	b. Secure with eight items (8) and (7)	Torque items (8) to 100-110 lb-ft.
<p><b>NOTE</b>  <b>Follow-on maintenance action required:</b>  <b>Apply grease to all fittings on interaxle shaft (LO 9-2320-283-12). Road test and check for unusual noise or vibration (TM 9-2320283-10).</b></p>		

PROPELLER SHAFTS AND UNIVERSAL JOINTS.

3-145. INTERAXLE PROPELLER SHAFT AND UNIVERSAL JOINTS REPLACEMENT (Continued).

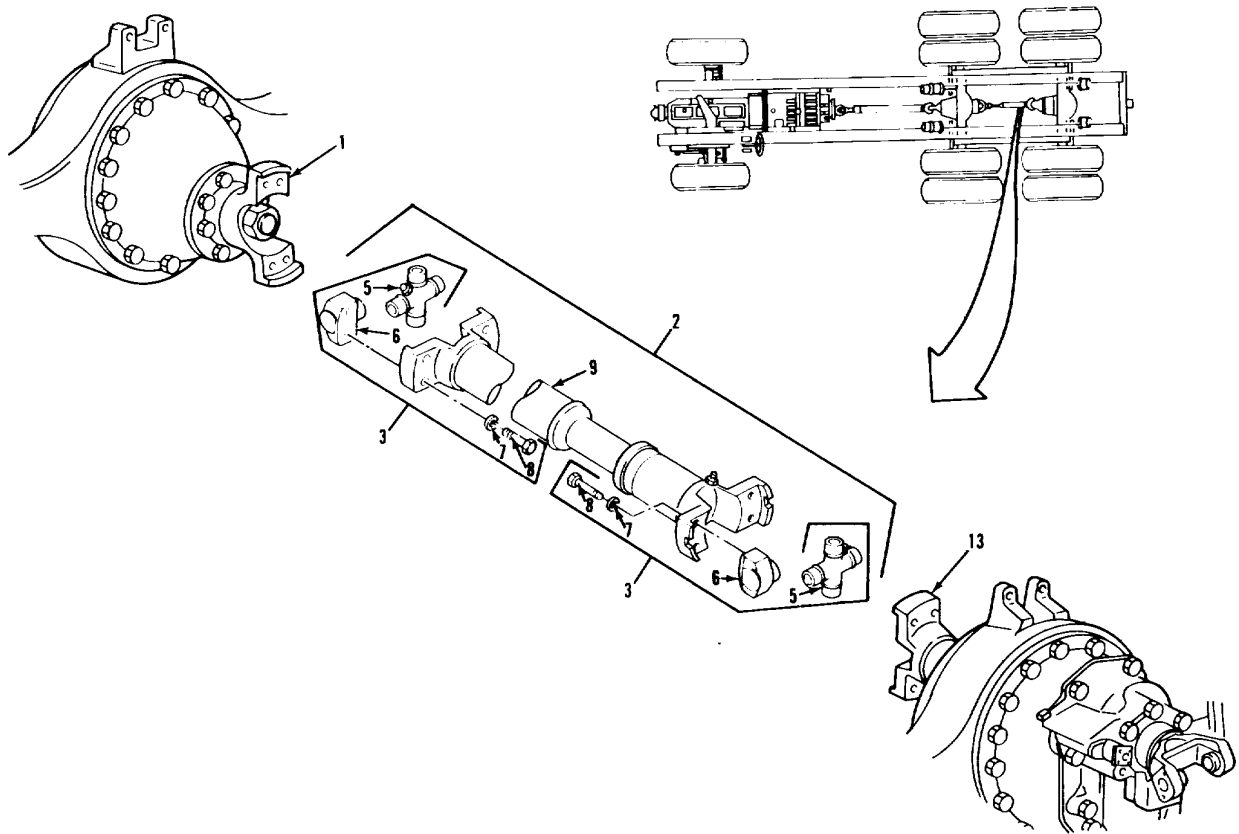

LEGEND:

- |                             |                           |
|-----------------------------|---------------------------|
| 1. OUTPUT SHAFT FLANGE      | 8. CAPSCREW (8)           |
| 2. INTERAXLE SHAFT ASSEMBLY | 9. SPLINED SHAFT          |
| 5. CENTER CROSS (2)         | 10. DUST SEAL             |
| 6. BEARING CUP ASSEMBLY (4) | 11. SLIP FLANGE           |
| 7. LOCKWASHER (8)           | 13. INPUT FLANGE ASSEMBLY |

TA 237409

**Section IX. FRONT AXLE**

**3-146. GENERAL.**

This section provides procedures authorized at the organizational maintenance level to replace front axle components. To find a specific procedure contained in this section, see the task summary below.

<b>3-147. TASK SUMMARY.</b>		
<b><u>INITIAL SETUP</u></b>		
<b><u>APPLICABLE CONFIGURATIONS</u></b> All	<b><u>EQUIPMENT CONDITION PARAGRAPH</u></b> (Refer to specific paragraph for this information).	<b><u>CONDITION DESCRIPTION</u></b>
<b><u>TEST EQUIPMENT</u></b> None.		
<b><u>SPECIAL TOOLS</u></b> Driver, bushing (52304) 700291. Indicator set, dial (33287) J 7872.		
<b><u>MATERIALS/PARTS (P/N)</u></b> Grease, automotive and artillery Item 7, Appendix C Kit, knuckle pin replacement (52304) H1005632 Pin, cotter (24617) 103389 Pin, cotter (52304) H1004797	 Key, woodruff (52304) H1004784. Pin, cotter (52304) H1004805. Pin, cotter (52304) H1004794. Key, woodruff (52304) H1004784.	
<b><u>PERSONNEL REQUIRED</u></b> Two IMOS-63S)	<b><u>SPECIAL ENVIRONMENTAL CONDITIONS</u></b> None.	
<b><u>REFERENCES (TM)</u></b> TM 9-2320-283-10 TM 9-2320-238-20P	<b><u>GENERAL SAFETY INSTRUCTIONS</u></b> Engine off. Transmission in neutral. Park brake set. Wheels blocked.	
<b><u>TROUBLESHOOTING REFERENCES</u></b> Paragraph 2-11.		
<b>3-876</b>		

## FRONT AXLE.

**3-147. TASK SUMMARY (Continued).****LIST OF TASKS**

<b>TASK NO</b>	<b>TASK</b>	<b>TASK REF</b>	<b>TROUBLESHOOTING REF NO. (PARA)</b>
1	Steering Arm Replacement	3-148	2-11
	a. Removal	3-148a	
	b. Cleaning and Inspection	3-148b	
	c. Installation	3-148c	
2	Steering Knuckle Assembly Replacement	3-149	2-11
	a. Removal	3-149a	
	b. Cleaning and Inspection	3-149b	
	c. Installation	3-149c	
3	Tie Rod Arm Replacement	3-150	2-11
	a. Removal	3-150a	
	b. Cleaning and Inspection	3-150b	
	c. Installation	3-150c	

**FRONT AXLE.**

<b>3-148. STEERING ARM REPLACEMENT.</b>		
<b><u>THIS TASK COVERS</u></b>		
<ul style="list-style-type: none"> <li>a. Removal.</li> <li>b. Cleaning and Inspection.</li> <li>c. Installation.</li> </ul>		
<b><u>INITIAL SETUP</u></b>		
<b><u>APPLICABLE CONFIGURATIONS</u></b>	<b><u>EQUIPMENT CONDITION PARAGRAPH</u></b>	<b><u>CONDITION DESCRIPTION</u></b>
All.	None.	None.
<b><u>TEST EQUIPMENT</u></b>		
None.		
<b><u>SPECIAL TOOLS</u></b>		
None.		
<b><u>MATERIALS/PARTS (P/N)</u></b>		
Pin, cotter (24617) 103389.		
Pin, cotter (52304) H1004797.		
Key, woodruff (52304) H1004784.		
<b><u>PERSONNEL REQUIRED</u></b>	<b><u>SPECIAL ENVIRONMENTAL CONDITIONS</u></b>	
One (MOS-63S).	None.	
<b><u>REFERENCES (TM)</u></b>	<b><u>GENERAL SAFETY INSTRUCTIONS</u></b>	
TM 9-2320-283-20P.	Engine off. Transmission in neutral. Park brake set.	
<b><u>TROUBLESHOOTING REFERENCES</u></b>		
Paragraph 2-11.		

FRONT AXLE.

3-148. STEERING ARM REPLACEMENT (Continued)

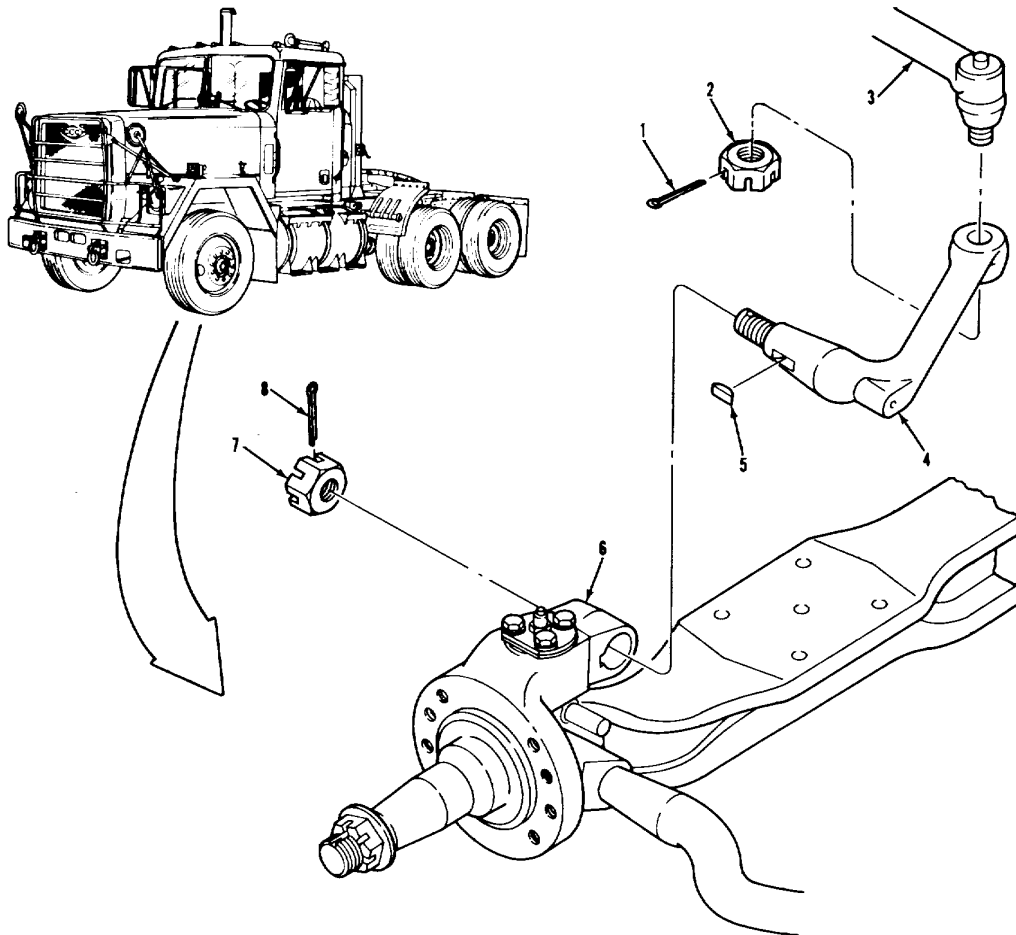

LEGEND:

- 1. COTTER PIN
- 2. CASTLE NUT
- 3. VERTICAL LINK ASSEMBLY
- 4. STEERING ARM
- 5. WOODRUFF KEY

- 6. LEFT-HAND STEERING KNUCKLE ASSEMBLY
- 7. HEXAGON NUT
- 8. COTTER PIN

TA 237410

## FRONT AXLE.

3-148. STEERING ARM REPLACEMENT (Continued).		
LOCATION/ITEM	ACTION	REMARKS
<b>A. REMOVAL.</b>		
1. Cotter pin (1)	Remove from items (2) and (3). Discard item (1).	
2. Nut (2)	Remove from item (3).	
3. Link (3)	Remove from item (4).	
4. Cotter pin (8)	Remove from items (7) and (4). Discard item (8).	
5. Nut (7)	Remove from item (4).	
6. Arm (4) and key (5)	Remove from item (6)	<p>a. Use a brass drift and hammer. Do not use heat.</p> <p>b. Discard item (5).</p>
<b>B. CLEANING AND INSPECTION.</b>		
7. All parts	Clean and inspect	Refer to paragraphs 3-4 and 3-5.
<b>C. INSTALLATION.</b>		
8. Arm (4) and new key (5).	Install in item (6).	
9. Nut (7) and new cotter pin (8)	Secure item (4) to item (6)	Torque to 350-490 lb-ft. Back off nut (7) to install pin (8), if necessary.
10. Link (3)	Install in item (4).	
11. Nut (2) and new cotter pin (1)	Secure item (3) to item (4)	Torque to 110-125 lb-ft. Tighten nut (2) more to install pin (1), if necessary.
<b>NOTE</b>		
Follow-on maintenance action required: None.		
<b>3-880</b>		



FRONT AXLE.

3-148. STEERING ARM REPLACEMENT (Continued).

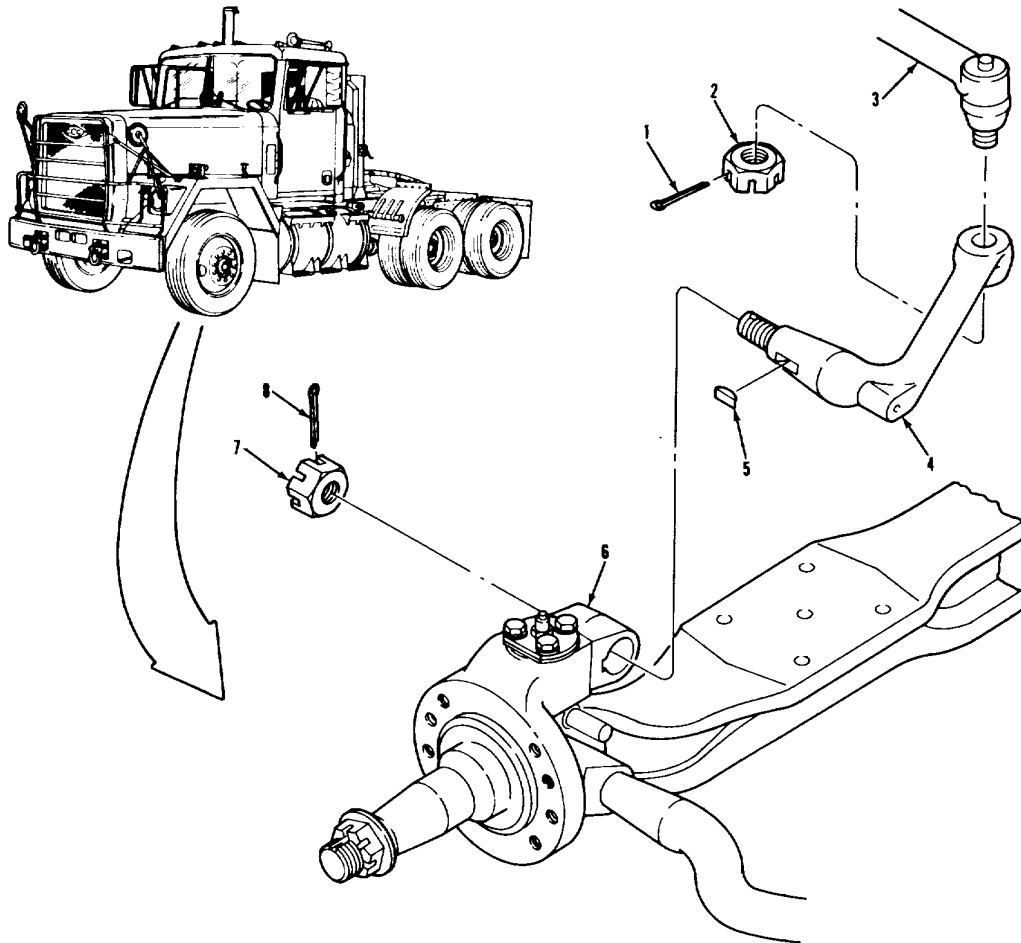

LEGEND:

- |                           |  |
|---------------------------|--|
| 1. COTTER PIN             | 6. LEFT-HAND STEERING KNUCKLE ASSEMBLY |
| 2. CASTLE NUT             | 7. HEXAGON NUT                         |
| 3. VERTICAL LINK ASSEMBLY | 8. COTTER PIN                          |
| 4. STEERING ARM           |  |
| 5. WOODRUFF KEY           |  |

TA 237411

**FRONT AXLE.**

<b>3-149. STEERING KNUCKLE ASSEMBLY REPLACEMENT</b>		
<b><u>THIS TASK COVERS</u></b>		
<ul style="list-style-type: none"> <li>a. Removal.</li> <li>b. Cleaning and Inspection.</li> <li>c. Installation.</li> </ul>		
<b><u>INITIAL SETUP</u></b>		
<b><u>APPLICABLE CONFIGURATIONS</u></b>	<b><u>EQUIPMENT CONDITION PARAGRAPH</u></b>	<b><u>CONDITION DESCRIPTION</u></b>
All	TM 9-2320-283-10	Wheel removed.
	3-204	Front drum removed.
<b><u>TEST EQUIPMENT</u></b>		
None	3-205	Front hub, bearings, and seals removed.
<b><u>SPECIAL TOOLS</u></b>	3-148	Steering arm removed (left side only).
Driver, bushing (52304) 700291. Indicator set, dial (33287) J 7872.	3-150	Tie rod arm removed.
<b><u>MATERIALS/PARTS (P/N)</u></b>		
Kit, knuckle pin replacement (52304) H1005632. Grease, automotive and artillery Item 7, Appendix C.		
<b><u>PERSONNEL REQUIRED</u></b>	<b><u>SPECIAL ENVIRONMENTAL CONDITIONS</u></b>	
Two (MOS-63S)	None.	
<b><u>REFERENCES (TM)</u></b>	<b><u>GENERAL SAFETY INSTRUCTIONS</u></b>	
TM 9-2320-283-10 TM 9-2320-283-20P	Engine off. Transmission in neutral. Park brake set. Wheels blocked.	
<b><u>TROUBLESHOOTING REFERENCES</u></b>		
Paragraph 2-11.		

FRONT AXLE.

**3-149. STEERING KNUCKLE ASSEMBLY REPLACEMENT.**

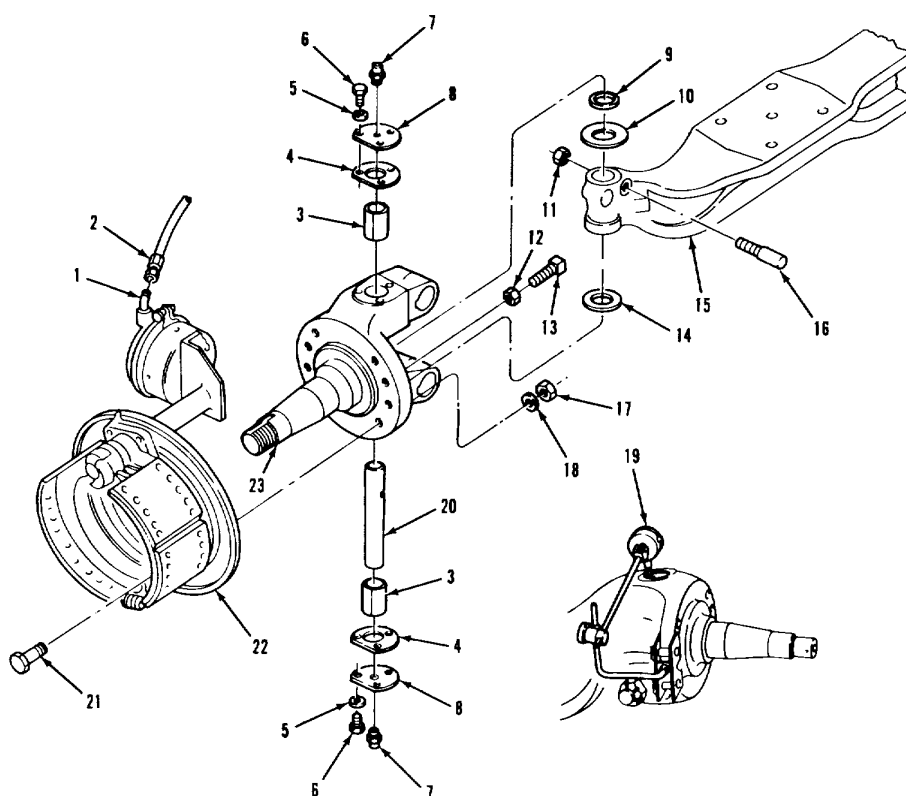

LEGEND:

- |                                 |                                  |
|---------------------------------|----------------------------------|
| 1. ELBOW                        | 13. STOP SCREW                   |
| 2. HOSE ASSEMBLY                | 14. THRUST PACK                  |
| 3. STEERING KNUCKLE BUSHING (2) | 15. AXLE BEAM                    |
| 4. KNUCKLE CAP GASKET (2)       | 16. DRAW KEY                     |
| 5. PLAIN WASHER (6)             | 17. HEX NUT (8)                  |
| 6. HEX HEAD SCREW (6)           | 18. HARDENED WASHER (8)          |
| 7. LUBRICATION FITTING (2)      | 19. DIAL INDICATOR SET           |
| 8. KNUCKLE CAP (2)              | 20. KNUCKLE PIN                  |
| 9. KNUCKLE PIN SEAL             | 21. SCREW (8)                    |
| 10. SHIM (AS REQUIRED)          | 22. FRONT SERVICE BRAKE ASSEMBLY |
| 11. LOCKNUT                     | 23. STEERING KNUCKLE ASSEMBLY    |
| 12. STOP SCREW LOCKNUT          |                                  |

TA 237412

FRONT AXLE.

**3-149. STEERING KNUCKLE ASSEMBLY REPLACEMENT.**

LOCATION/ITEM	ACTION	REMARKS
---------------	--------	---------

**NOTE**

- **Steering knuckle replacement is the same for both sides.**
- **Knuckle pin replacement kit contains parts for both sides.**

A. REMOVAL

1. Hose assembly (2).	Remove from item (1).	
2. Eight screws (21), washers (18), and nuts (17).	Remove from item (22) and item (23).	
3. Brake assembly (22).	Remove from item (23).	Assistant helps mechanic.
4. Six screws (6), six washers (5), and two fittings (7).	Remove from two items (8) and discard.	
5. Two caps (8) and gaskets (4).	Remove from item (23) and discard.	
6. Locknut (11).	Remove from item (16) and discard.	
7. Key (16).	Remove from item (15) and discard.	Use a brass or bronze hammer or drift.
8. Pin (20).	Remove from item (23) and item (15), then discard.	Use a brass or bronze drift.
9. Knuckle assembly (23), shims (10), and thrust pack (14).	Remove from item (15).	Discard item (14).
10. Seal (9) and two bushings (3).	Remove from item (23) and discard.	Use bushing driver and a brass hammer.
11. Screw (13) and locknut (12).	Remove from item (23). ½" > y	

FRONT AXLE.

3-149. STEERING KNUCKLE ASSEMBLY REPLACEMENT.

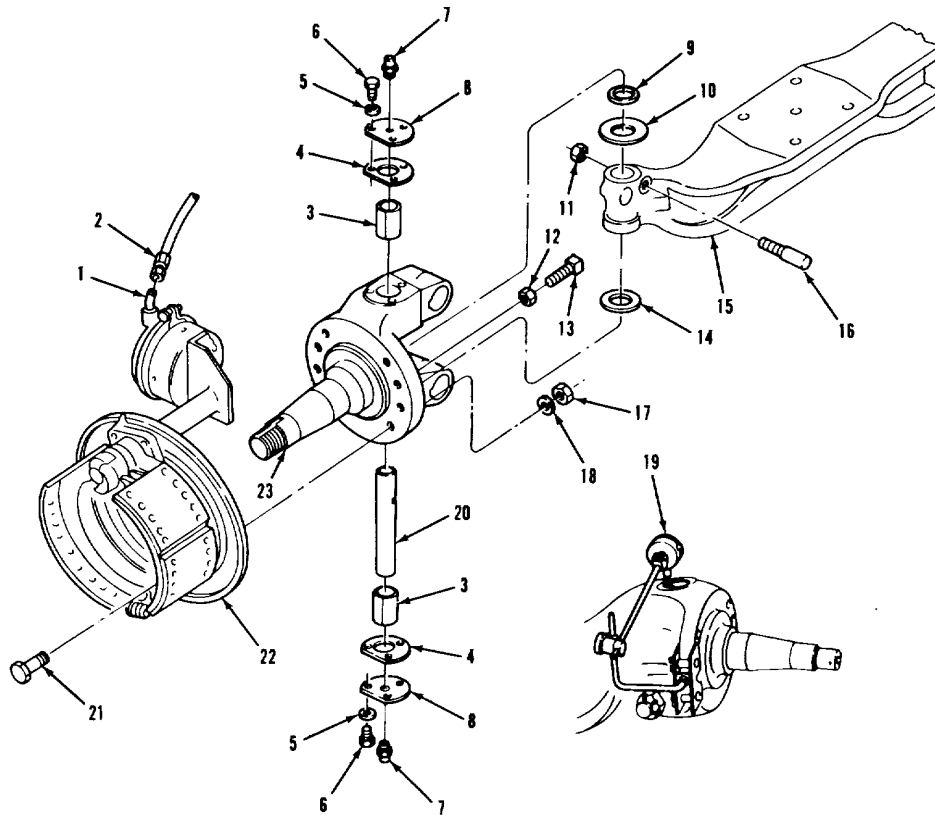

LEGEND:

- |                                 |                                  |
|---------------------------------|----------------------------------|
| 1. ELBOW                        | 13. STOP SCREW                   |
| 2. HOSE ASSEMBLY                | 14. THRUST PACK                  |
| 3. STEERING KNUCKLE BUSHING (2) | 15. AXLE BEAM                    |
| 4. KNUCKLE CAP GASKET (2)       | 16. DRAW KEY                     |
| 5. PLAIN WASHER (6)             | 17. HEX NUT (8)                  |
| 6. HEX HEAD SCREW (6)           | 18. HARDENED WASHER (8)          |
| 7. LUBRICATION FITTING (2)      | 19. DIAL INDICATOR SET           |
| 8. KNUCKLE CAP (2)              | 20. KNUCKLE PIN                  |
| 9. KNUCKLE PIN SEAL             | 21. SCREW (8)                    |
| 10. SHIM (AS REQUIRED)          | 22. FRONT SERVICE BRAKE ASSEMBLY |
| 11. LOCKNUT                     | 23. STEERING KNUCKLE ASSEMBLY    |
| 12. STOP SCREW LOCKNUT          |                                  |

TA 237413

**FRONT AXLE.**

**3-149. STEERING KNUCKLE ASSEMBLY REPLACEMENT.**

LOCATION/ITEM	ACTION	REMARKS
<u>B. CLEANING AND INSPECTION</u>		
12. All parts. and 3-5.	Clean and inspect.	Refer to paragraphs 3-4
<u>C. INSTALLATION.</u>		
13. Two new bushings (3).	a. Lightly lubricate with grease. b. Start in item (23) by hand. c. Drive into item (23) with bushing driver and a brass hammer until mark on driver is flush with item (23).	
14. New seal (9).	a. Lightly lubricate with grease. b. Install in item (23) with bushing driver and a brass hammer.	
15. Axle beam (15) and knuckle assembly (23).	Lightly lubricate machined surfaces with grease.	
16. New thrust pack (14).	Put on item (23).	Rubber side faces down.
17. New pin (20).	Put in item (23) from bottom until just flush with item (14).	Be sure end marked "top" faces up.
18. Knuckle assembly (23).	Put in place on item (15).	
19. Pin (20).	a. Line up flat with hole for item (16). b. Drive halfway into item (15).	

FRONT AXLE.

**3-149. STEERING KNUCKLE ASSEMBLY REPLACEMENT.**

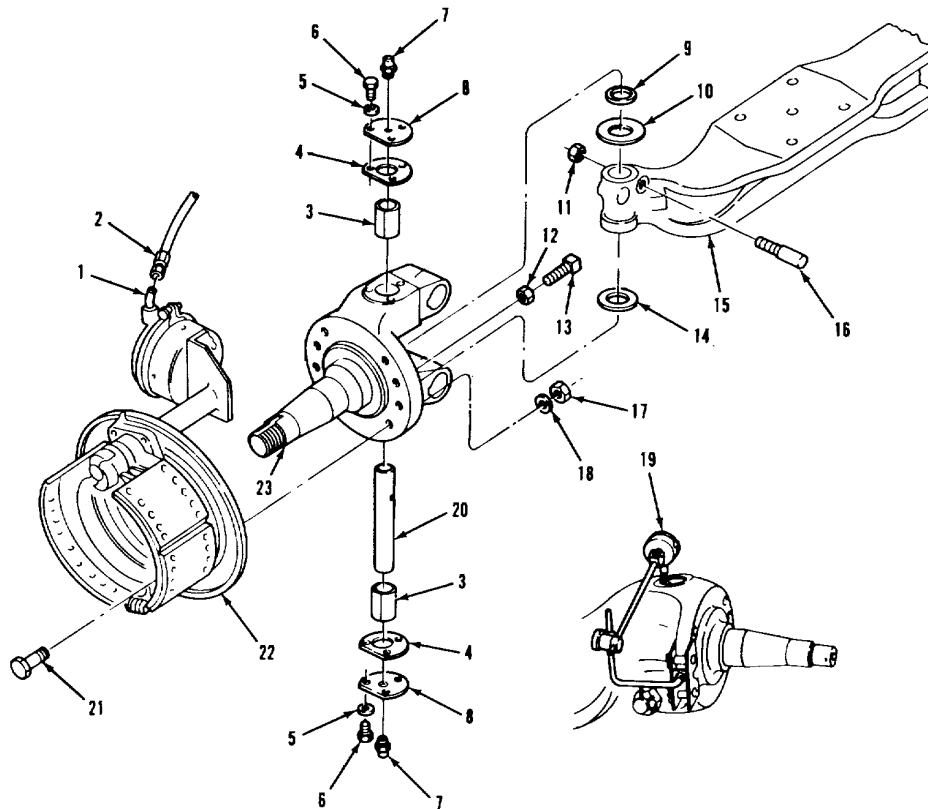

LEGEND:

- |                                 |                                  |
|---------------------------------|----------------------------------|
| 1. ELBOW                        | 13. STOP SCREW                   |
| 2. HOSE ASSEMBLY                | 14. THRUST PACK                  |
| 3. STEERING KNUCKLE BUSHING (2) | 15. AXLE BEAM                    |
| 4. KNUCKLE CAP GASKET (2)       | 16. DRAW KEY                     |
| 5. PLAIN WASHER (6)             | 17. HEX NUT (8)                  |
| 6. HEX HEAD SCREW (6)           | 18. HARDENED WASHER (8)          |
| 7. LUBRICATION FITTING (2)      | 19. DIAL INDICATOR SET           |
| 8. KNUCKLE CAP (2)              | 20. KNUCKLE PIN                  |
| 9. KNUCKLE PIN SEAL             | 21. SCREW (8)                    |
| 10. SHIM (AS REQUIRED)          | 22. FRONT SERVICE BRAKE ASSEMBLY |
| 11. LOCKNUT                     | 23. STEERING KNUCKLE ASSEMBLY    |
| 12. STOP SCREW LOCKNUT          |                                  |

TA 237414

## FRONT AXLE.

**3-149. STEERING KNUCKLE ASSEMBLY REPLACEMENT.**

LOCATION/ITEM	ACTION	REMARKS
<u>C. INSTALLATION (Continued).</u>		
20. Shim (10).	Put as many as possible between item (15) and item (9).	Pry up on item (23) with small pry bar.
21. Pin (20).	Drive into item (15) and item (23) until item (16) can be installed.	
22. New key (16).	Install in item (15). or bronze drift.	Tap in with brass hammer
23. New locknut (11).	Secure item (16). 45 lb-ft.	Torque between 30 and 45 lb-ft.
24. Indicator (19).	a. Secure to item (23). b. Zero against item (20). c. Push up on item (23) with a suitable jack and read item (19).	Reading should be between .005 and .025 inches. If not, repeat steps 6 thru 8, and 19 thru 24, adding or removing items (10) as necessary.
25. Two new caps (8) and new gasket (4).	d. Remove from item (23). Install on item (20).	
26. Six new screws (6) and new washers (5).	Secure two items (4) to item (23).	Torque between 22 and 28 lb-ft.
27. Two new fittings (7).	a. Install in two items (8). b. Pump full of grease with grease gun.	

3-888



FRONT AXLE.

**3-149. STEERING KNUCKLE ASSEMBLY REPLACEMENT.**

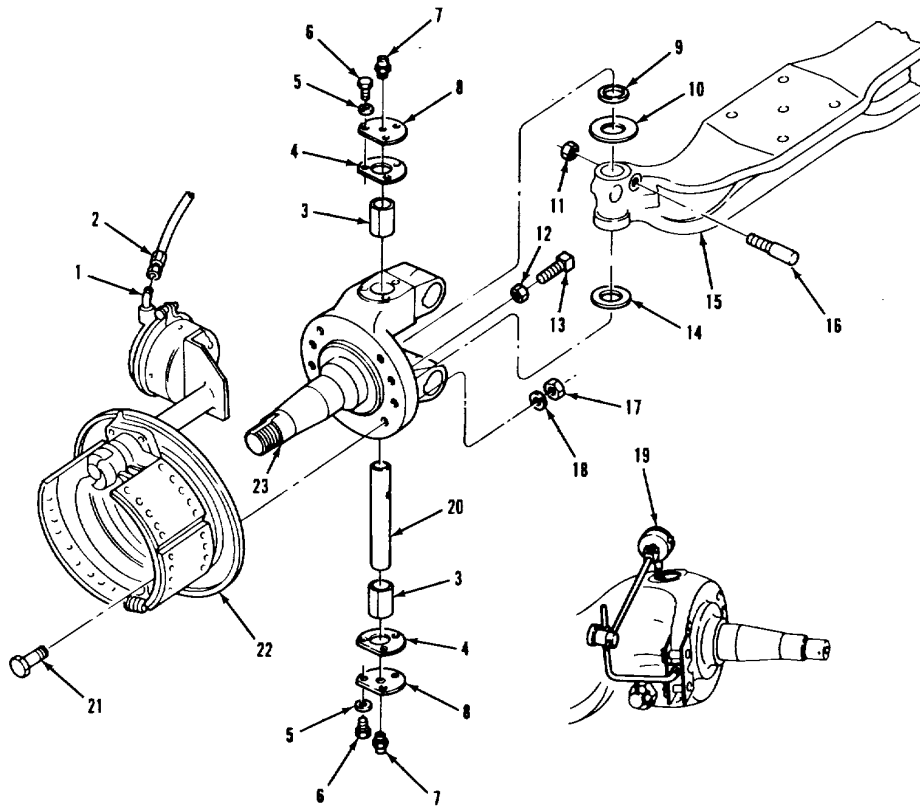

LEGEND:

- |                                 |                                  |
|---------------------------------|----------------------------------|
| 1. ELBOW                        | 13. STOP SCREW                   |
| 2. HOSE ASSEMBLY                | 14. THRUST PACK                  |
| 3. STEERING KNUCKLE BUSHING (2) | 15. AXLE BEAM                    |
| 4. KNUCKLE CAP GASKET (2)       | 16. DRAW KEY                     |
| 5. PLAIN WASHER (6)             | 17. HEX NUT (8)                  |
| 6. HEX HEAD SCREW (6)           | 18. HARDENED WASHER (8)          |
| 7. LUBRICATION FITTING (2)      | 19. DIAL INDICATOR SET           |
| 8. KNUCKLE CAP (2)              | 20. KNUCKLE PIN                  |
| 9. KNUCKLE PIN SEAL             | 21. SCREW (8)                    |
| 10. SHIM (AS REQUIRED)          | 22. FRONT SERVICE BRAKE ASSEMBLY |
| 11. LOCKNUT                     | 23. STEERING KNUCKLE ASSEMBLY    |
| 12. STOP SCREW LOCKNUT          |                                  |

TA 237415

## FRONT AXLE.

**3-149. STEERING KNUCKLE ASSEMBLY REPLACEMENT.**

LOCATION/ITEM	ACTION	REMARKS
<u>C. INSTALLATION (Continued).</u>		
28. Screw (13) and locknut (12).	Install in item (23).	Torque between 40 and 50 lb-ft.
29. Brake assembly (22).	Install on item (23).	Assistant helps mechanic.
30. Eight screws (21), washers (18), and nuts (17).	Secure item (22) to item (23).	Torque between 90 and 100 lb-ft.
31. Hose assembly (2).	Install on item (1).	
<b>NOTE</b>		
<b>Follow-on maintenance action required:</b>		
<b>Install tie rod arm (para 3-150).</b> <b>Install steering arm (left side only) (para 3-148).</b> <b>Install front hub, bearings, and seals (para 3-205).</b> <b>Install front drum (para 3-204).</b> <b>Install front wheel (TM 9-2320-283-10).</b> <b>Aline front wheels (para 3-203).</b>		
<b>3-890</b>		

FRONT AXLE.

3-149. STEERING KNUCKLE ASSEMBLY REPLACEMENT.

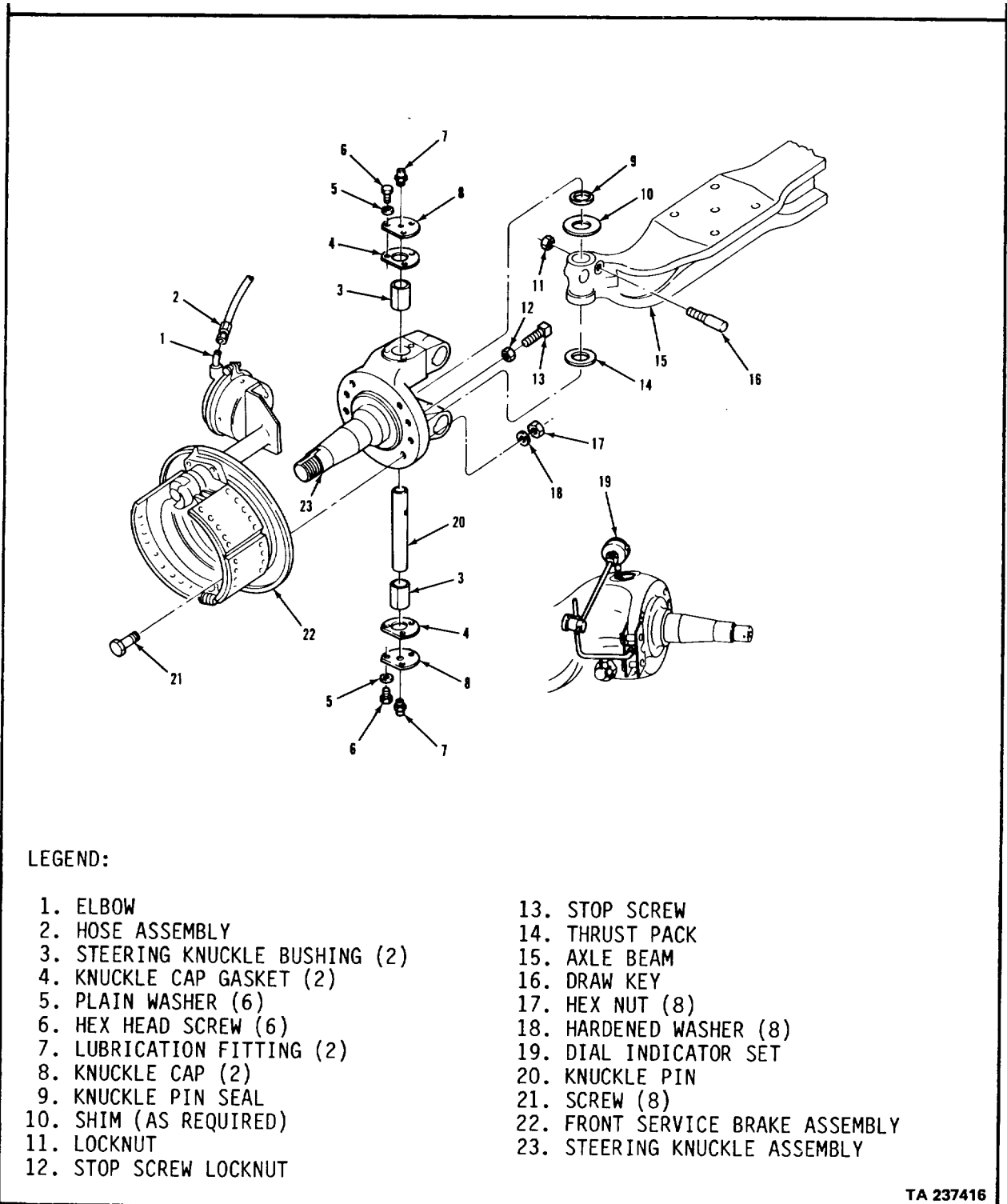

TA 237416

**FRONT AXLE.**

**3-150. TIE ROD ARM REPLACEMENT.**

THIS TASK COVERS

- a. Removal.
- b. Cleaning and Inspection.
- c. Installation.

INITIAL SETUP

APPLICABLE CONFIGURATIONS

All.

EQUIPMENT CONDITION

PARAGRAPH

None.

CONDITION DESCRIPTION

None.

TEST EQUIPMENT

None.

SPECIAL TOOLS

None.

MATERIALS/PARTS (P/N)

Pin, cotter  
(52304) H1004805.

Pin, cotter  
(52304) H1004797.

Key, woodruff  
(52304) H1004784.

PERSONNEL REQUIRED

One (MOS-63S .

REFERENCES (TM)

TM 9-2320-283-20P.

SPECIAL ENVIRONMENTAL CONDITIONS

None.

GENERAL SAFETY INSTRUCTIONS

Engine off.  
Transmission in neutral.  
Park brake set.

TROUBLESHOOTING REFERENCES

Paragraph 2-11.

FRONT AXLE.

3-150. TIE ROD ARM REPLACEMENT (Continued).

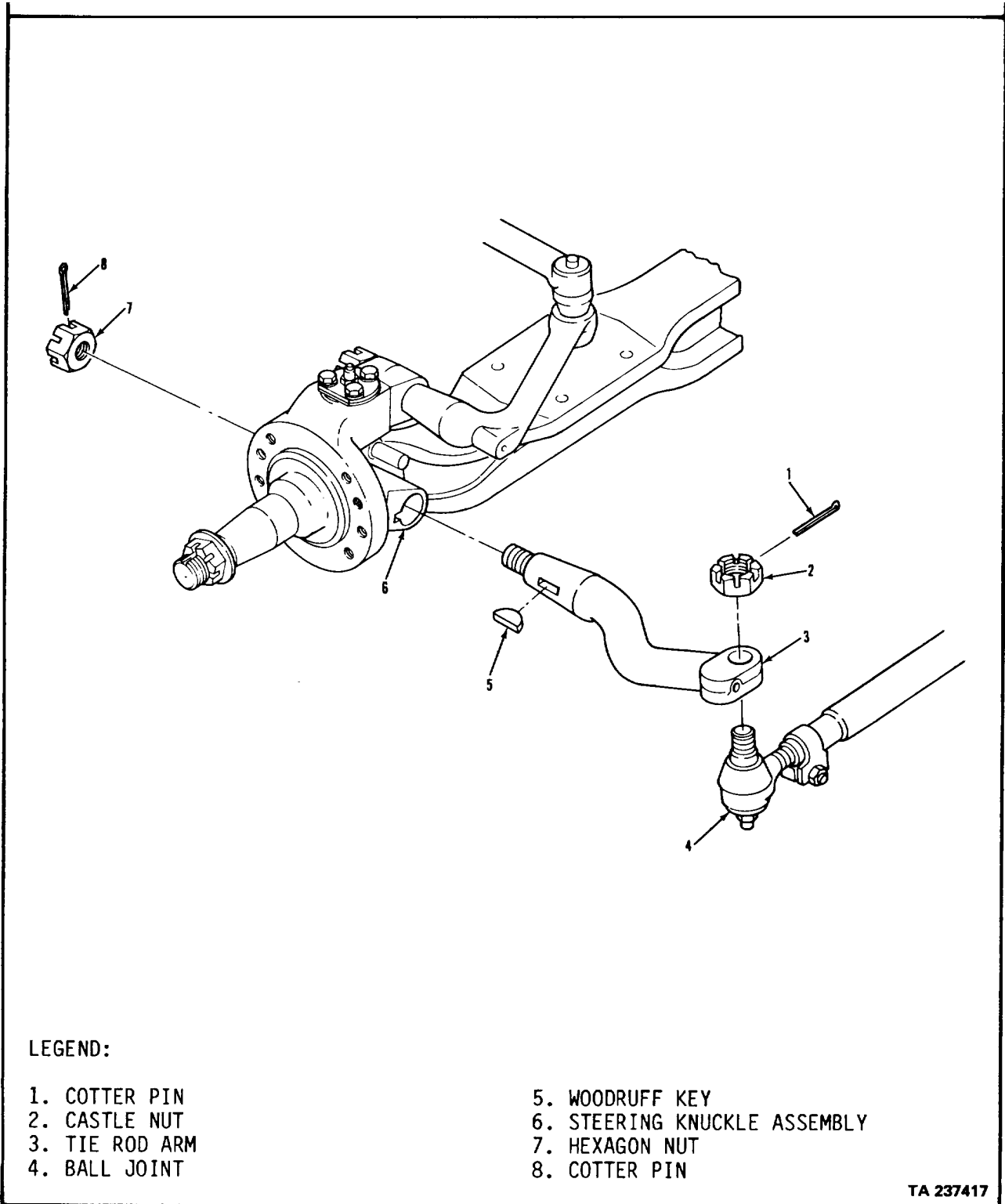

FRONT AXLE.

**3-150. TIE ROD ARM REPLACEMENT (Continued).**

LOCATION/ITEM	ACTION	REMARKS
---------------	--------	---------

**NOTE**

**Replacement of tie rod arms is same for both sides.**

A. REMOVAL.

1. Cotter pin (1).	Remove from item (2).	Discard item (1).
2. Nut (2).	Remove from item (4).	
3. Ball joint (4).	Remove from item (3).	Use a suitable puller.
4. Cotter pin (8).	Remove from item (7).	Discard item (8).
5. Nut (7).	Remove from item (3).	
6. Arm (3) and key (5).	Remove from item (6) and discard item (5).	Use a brass hammer or bronze drift.

B. CLEANING AND INSPECTION.

7. All parts.	Clean and inspect.	Refer to paragraphs 3-4 and 3-5.
---------------	--------------------	----------------------------------

C. INSTALLATION.

8. Arm (3) and new key (5).	Install in item (6).	
9. Nut (7) and new cotter pin (8).	Secure item (3) to item (6).  item (8).	Torque between 350 and 490 lb-ft. Loosen if necessary to install
10. Ball joint (4).	Install in item (3).	
11. Nut (2) and new cotter pin (1).	Secure item (4) to item (3).	Torque between 165 and 230 lb-ft. Tighten if necessary to install item (1).

**NOTE**

**Follow-on maintenance action required:**

**Check front wheel alinement (para 3-205).**

FRONT AXLE.

3-150. TIE ROD ARM REPLACEMENT (Continued).

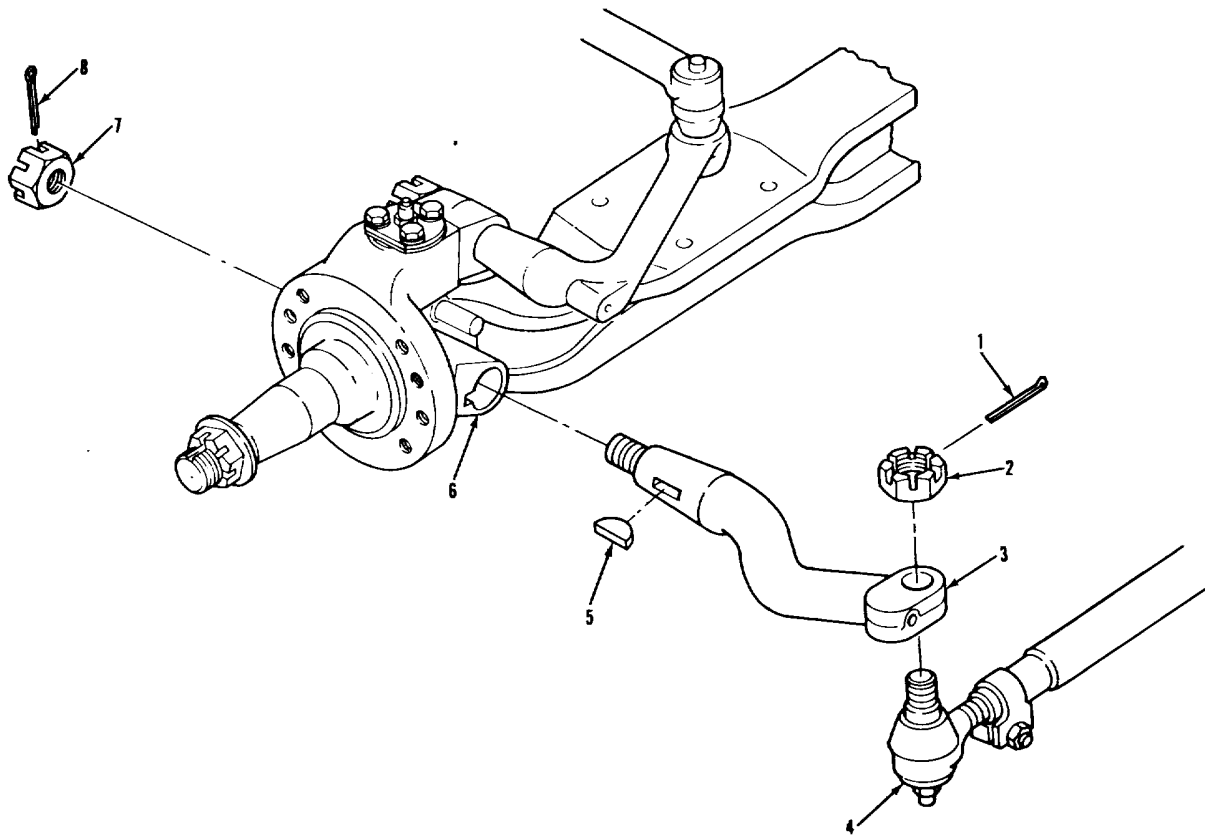

LEGEND:

- 1. COTTER PIN
- 2. CASTLE NUT
- 3. TIE ROD ARM
- 4. BALL JOINT

- 5. WOODRUFF KEY
- 6. STEERING KNUCKLE ASSEMBLY
- 7. HEXAGON NUT
- 8. COTTER PIN

TA 237418

**Section X. REAR AXLE**

**3-151. GENERAL.**

This section provides procedures authorized at the organizational maintenance level to service and replace rear axle components. To find a specific procedure contained in this section, see the task summary below.

**3-152. TASK SUMMARY.**

INITIAL SETUP

APPLICABLE CONFIGURATIONS

All.

EQUIPMENT CONDITION

PARAGRAPH

CONDITION DESCRIPTION

(Refer to specific paragraph for this information).

TEST EQUIPMENT

None.

SPECIAL TOOLS

None.

MATERIALS/PARTS (P/N)

Solvent, drycleaning, SD-2

Item 29, Appendix C.

Container(s), 40 pint capacity.

Gasket, axle shaft

(52304) 13886.

Compound, gasket, Permatex®, No. 2C

Item 6, Appendix C.

PERSONNEL REQUIRED

One (MOS-63S).

SPECIAL ENVIRONMENTAL CONDITIONS

None.

REFERENCES (TM)

TM 9-2320-283-10.

TM 9-2320-283-20P.

L0 9-2320-238-12.

GENERAL SAFETY INSTRUCTIONS

Engine off.

Transmission in neutral.

Park brake set.

TROUBLESHOOTING REFERENCES

Paragraph 2-11.

**3-896**



REAR AXLE.

**3-152. TASK SUMMARY (Continued).**

**LIST OF TASKS**

TASK NO.	TASK	TASK REF	TROUBLESHOOTING REF NO. (PARA)
1	Rear Axle Oil Service a. Draining. b. Filling.	3-153 3-153a 3-153b	2-11
2	Rear Axle Shaft Replacement a. Removal. b. Cleaning and Inspection. c. Installation.	3-154 3-154a 3-154b 3-154c	2-11

**3-897**

REAR AXLE.

**3-153. REAR AXLE OIL SERVICE.**

THIS TASK COVERS

- a. Draining.
- b. Filling.

INITIAL SETUP

APPLICABLE CONFIGURATIONS

All.

EQUIPMENT CONDITION PARAGRAPH

None.

CONDITION DESCRIPTION

Axle oil warm. (Do service procedure immediately after truck has been driven).

TEST EQUIPMENT

None.

SPECIAL TOOLS

None.

MATERIALS/PARTS (P/N)

Container(s), 40 pint capacity.  
Solvent, drycleaning, SD-2  
Item 29, Appendix C.

PERSONNEL REQUIRED

One (MOS-63S).

SPECIAL ENVIRONMENTAL CONDITIONS

None.

REFERENCES (TM)

TM 9-2320-283-10.  
LO 9-2320-283-12.

GENERAL SAFETY INSTRUCTIONS

Engine off.  
Transmission in neutral.  
Park brake set.

TROUBLESHOOTING REFERENCES

Paragraph 2-11.

REAR AXLE.

3-153. REAR AXLE OIL SERVICE (Continued).

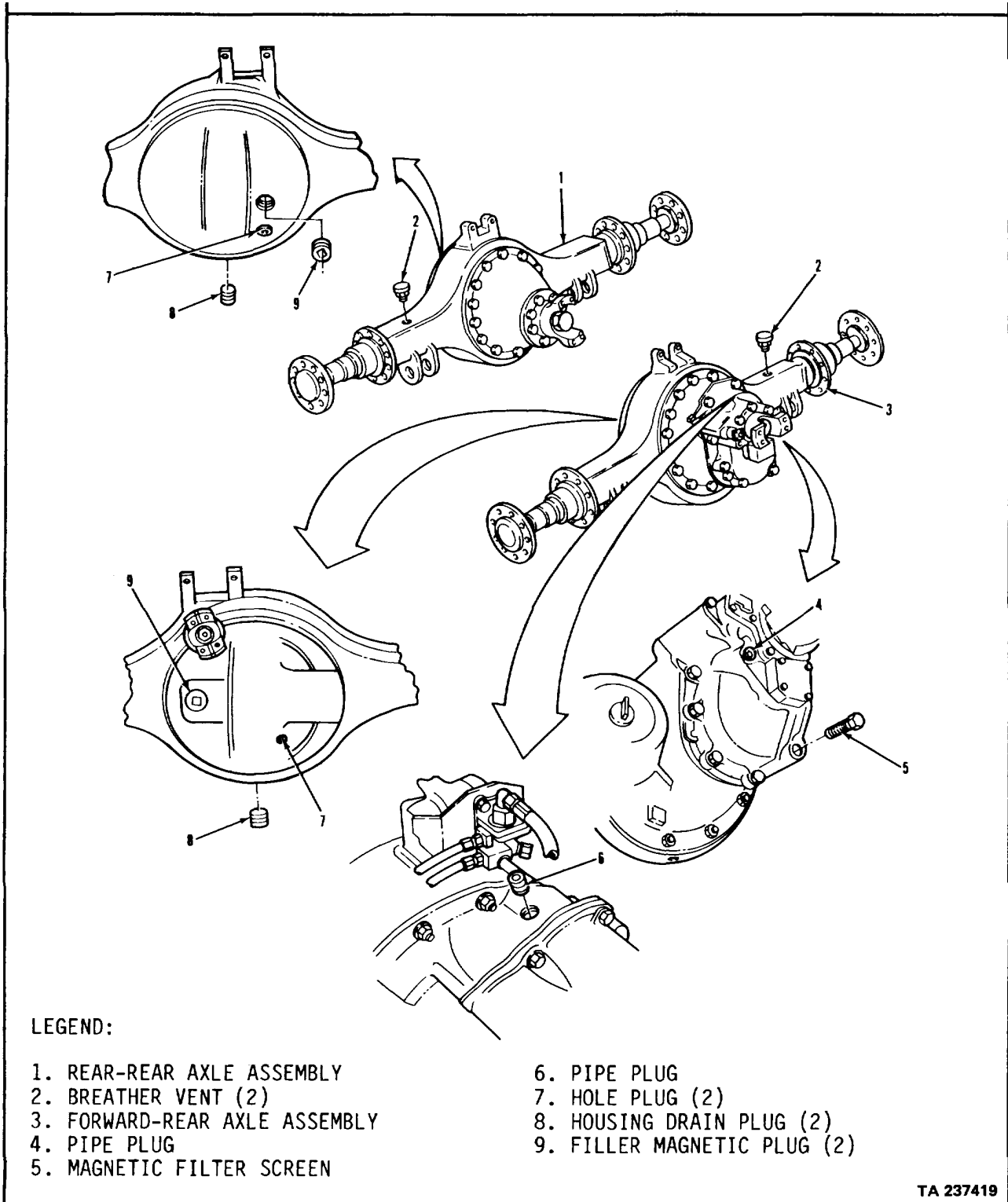

TA 237419

REAR AXLE.

**3-153. REAR AXLE OIL SERVICE (Continued).**

LOCATION/ITEM	ACTION	REMARKS
<b>A. DRAINING.</b>		
1. Two plugs (9) and plug (6). 1	a. Remove from item (1) and Item (3). b. Inspect for excessive metal chips.	If excessive chips are found, refer to DS/GS maintenance.
<b>NOTE</b> <b>Have suitable container(s) ready to catch oil.</b>		
2. Two plugs (8). item (3).	a. Remove from item (1) and b. Install in item (1) and item (3).	Let all oil drain out.
3. Screen (5) and two vents (2).	Remove from item (1) and item (3).	
4. Screen (5).	Inspect for excessive metal chips.	If excessive chips are found, refer to DS/GS maintenance.
<b>WARNING</b> <b>Compressed air used for cleaning purposes will not exceed 30 psi. Use only with effective chip guarding and personal protective equipment (goggles/shield, gloves, etc.).</b>		
<b>3-900</b>		

REAR AXLE.

3-153. REAR AXLE OIL SERVICE (Continued).

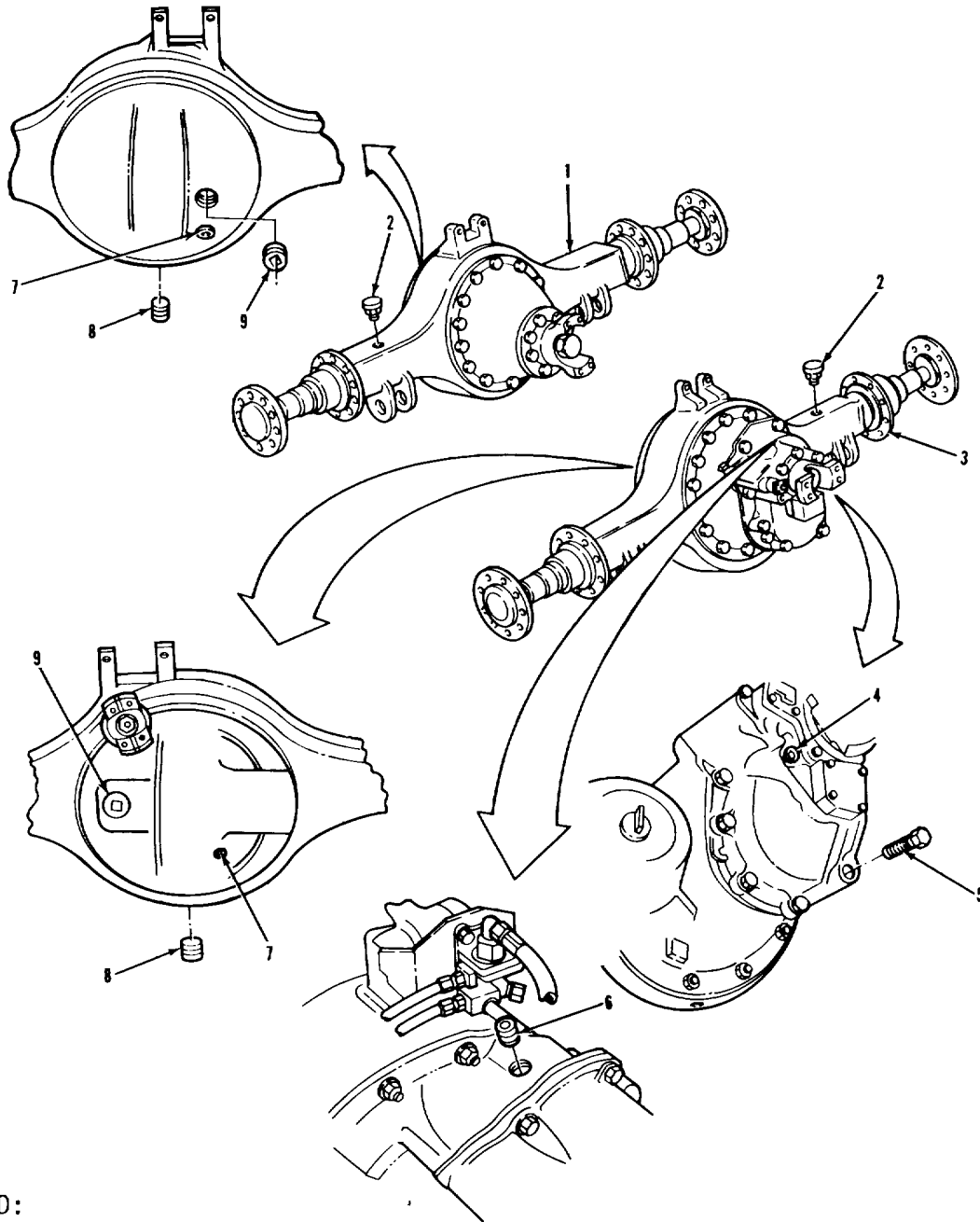

LEGEND:

- 1. REAR-REAR AXLE ASSEMBLY
- 2. BREATHER VENT (2)
- 3. FORWARD-REAR AXLE ASSEMBLY
- 4. PIPE PLUG
- 5. MAGNETIC FILTER SCREEN

- 6. PIPE PLUG
- 7. HOLE PLUG (2)
- 8. HOUSING DRAIN PLUG (2)
- 9. FILLER MAGNETIC PLUG (2)

TA 237420

REAR AXLE.

**3-153. REAR AXLE OIL SERVICE (Continued).**

LOCATION/ITEM	ACTION	REMARKS
<u>A. DRAINING (Continued).</u>		
5. Screen (5) and two vents (2).	a. Clean with solvent and stiff brush. compressed air.	Dry with
	b. Install in item (1) and item (3).	
6. Two plugs (7) and plug (4).	Inspect for leakage.	If leaking, replace.
<u>B. FILLING</u>		
7. Axle assembly (1) and axle assembly (3).	a. Fill with proper oil.	Refer to LO 9-2320-283-12.
	b. Raise left side at least four inches for about two minutes.	Refer to TM 9-2320-283-10.
	c. Raise right side at least four inches for about two minutes.	Refer to TM 9-2320-283-10.
	d. Recheck oil level and fill as necessary.	Refer to LO 9-2320-283-12.
8. Two plugs (9).	Install in item (1) and item (3).	
9. Axle assembly (3).	Pour two pints of proper oil in hole in top.	Refer to LO 9-2320-283-12.
10. Plug (6).	Install in item (3).	

**NOTE**  
**Follow-on maintenance action required:**  
**None.**

**3-902**

REAR AXLE.

3-153. REAR AXLE OIL SERVICE (Continued).

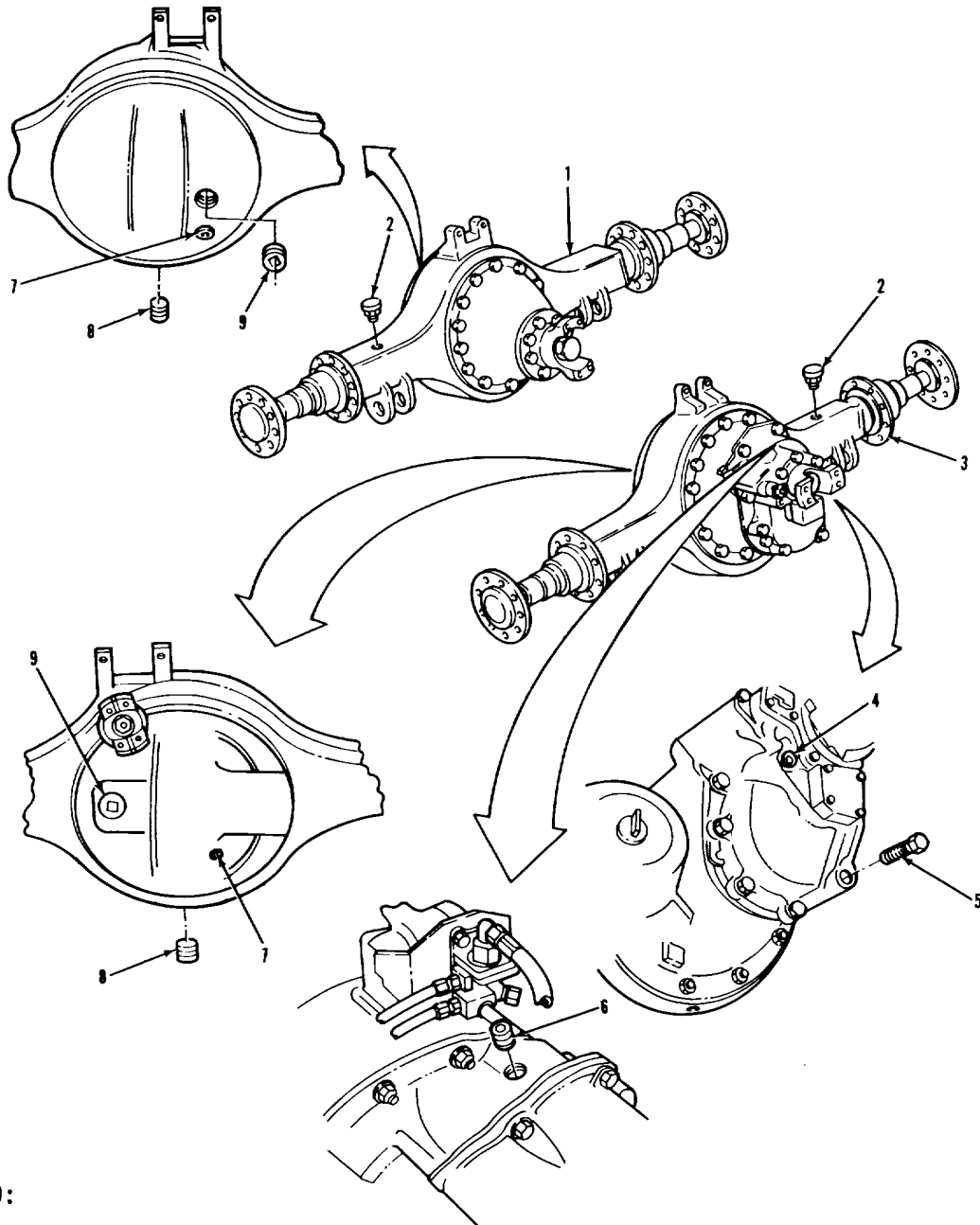

LEGEND:

- |                               |                             |
|-------------------------------|-----------------------------|
| 1. REAR-REAR AXLE ASSEMBLY    | 6. PIPE PLUG                |
| 2. BREATHER VENT (2)          | 7. HOLE PLUG (2)            |
| 3. FORWARD-REAR AXLE ASSEMBLY | 8. HOUSING DRAIN PLUG (2)   |
| 4. PIPE PLUG                  | 9. FILLER MAGNETIC PLUG (2) |
| 5. MAGNETIC FILTER SCREEN     |                             |

TA 237421

REAR AXLE.

**3-154. REAR AXLE SHAFT REPLACEMENT.**

THIS TASK COVERS  
 a. Removal.  
 b. Cleaning and Inspection.  
 c. Installation.

<u>INITIAL SETUP</u>		
<u>APPLICABLE CONFIGURATIONS</u>	<u>EQUIPMENT CONDITION PARAGRAPH</u>	<u>CONDITION DESCRIPTION</u>
All. None.	None.	
<u>TEST EQUIPMENT</u>		
None.		
<u>SPECIAL TOOLS</u>		
None.		
<u>MATERIALS/PARTS (P/N)</u>		
Gasket, axle shaft (52304) 13886. Compound, gasket, Permatex®, No. 2C Item 6, Appendix C.		
<u>PERSONNEL REQUIRED</u>	<u>SPECIAL ENVIRONMENTAL CONDITIONS</u>	
One (MOS-63S).	None.	
<u>REFERENCES (TM)</u>	<u>GENERAL SAFETY INSTRUCTIONS</u>	
TM 9-2320-283-10. TM 9-2320-283-20P. L0 9-2320-283-12.	Engine off. Transmission in neutral. Park brake set.	
<u>TROUBLESHOOTING REFERENCES</u>		
Paragraph 2-11.		



REAR AXLE.

3-154. REAR AXLE SHAFT REPLACEMENT (Continued).

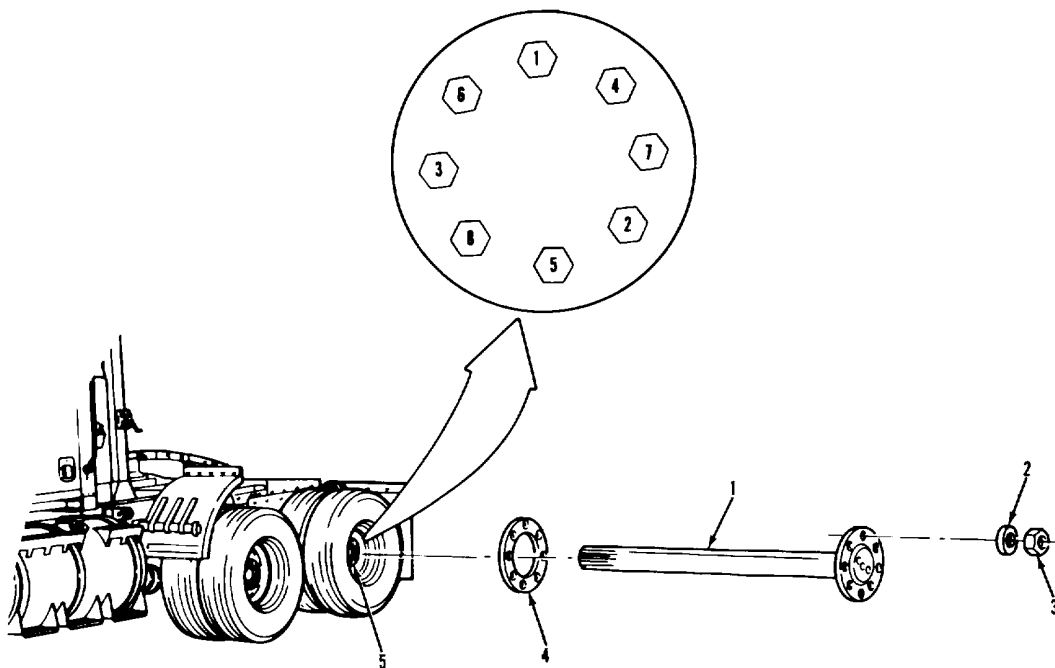

LEGEND:

- 1. AXLE SHAFT
- 2. HARDENED WASHER (8)
- 3. HEX NUT (8)

- 4. AXLE SHAFT GASKET
- 5. HUB ASSEMBLY

TA 237422

REAR AXLE.

3-154. REAR AXLE SHAFT REPLACEMENT (Continued).		
LOCATION/ITEM	ACTION	REMARKS
<b>NOTE</b>		
<ul style="list-style-type: none"> <li>• Replacement is the same for any of the axle shafts.</li> <li>• Wheels may be raised several inches to prevent oil loss (TM 9-2320-283-10).</li> </ul>		
<u>A. REMOVAL.</u>		
1. Eight nuts (3) and washers (2).	Remove from item (1).	
2. Shaft (1) and gasket (4).	Remove from item (5).	<ul style="list-style-type: none"> <li>a. Several blows with a hammer may be needed to loosen shaft.</li> <li>b. Discard item (4).</li> </ul>
<u>B. CLEANING AND INSPECTION</u>		
3. All parts.	Clean and inspect.	Refer to paragraphs 3-4 and 3-5.
<u>C. INSTALLATION.</u>		
4. New gasket (4) sides.	Put gasket compound on both	
5. Shaft (1) and new gasket (4).	Install in item (5).	
6. Eight nuts (3) and washers (2).	Secure item (1) to item (5).	<ul style="list-style-type: none"> <li>a. Torque between 90 and 120 lb-ft.</li> <li>b. Tighten in order shown.</li> </ul>
<b>NOTE</b>		
<b>Follow-on maintenance action required:</b> <b>Lubricate hub bearings (LO 9-2320-283-12).</b>		
<b>3-906</b>		

REAR AXLE.

3-154. REAR AXLE SHAFT REPLACEMENT (Continued).

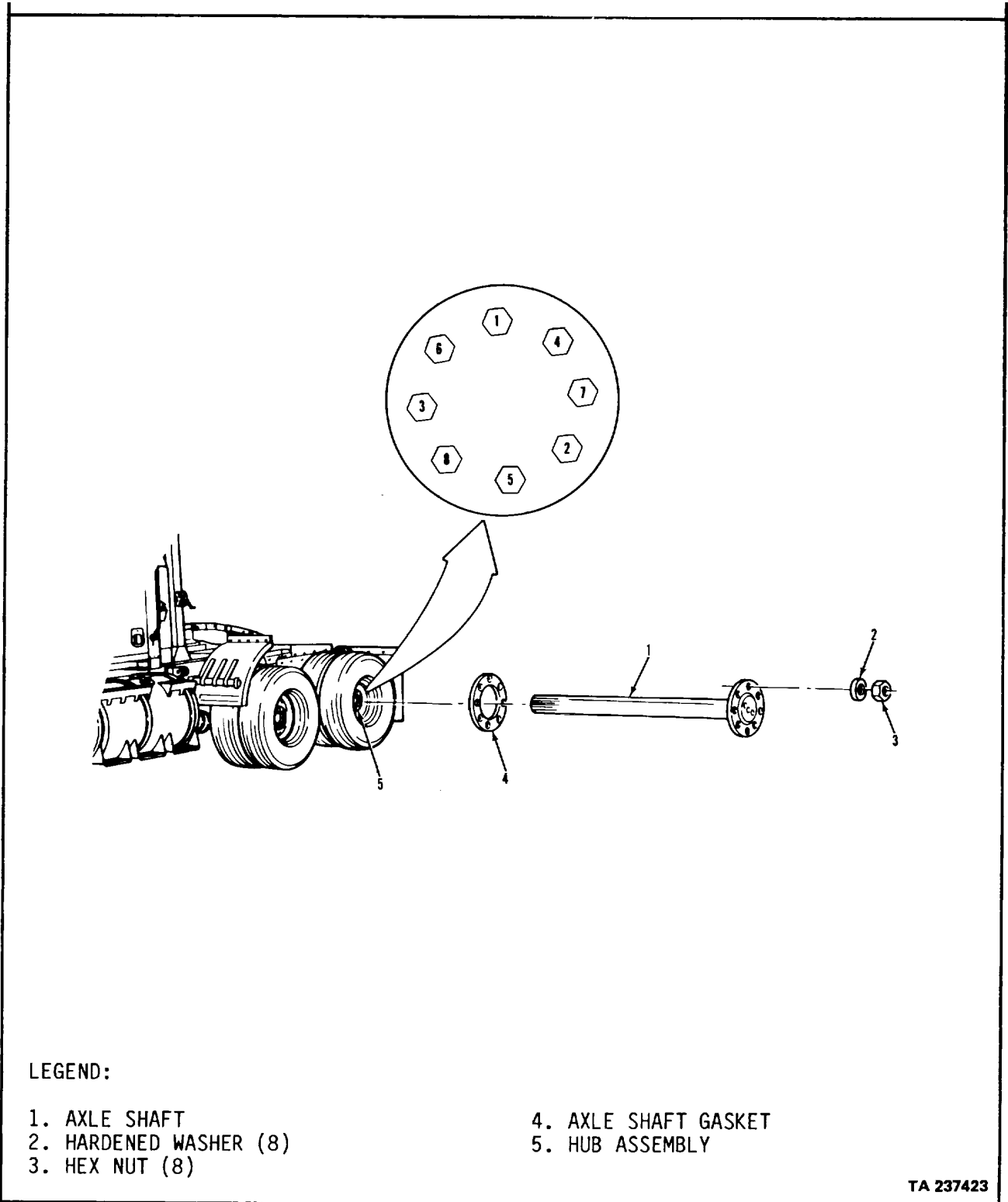

Section XI. BRAKE SYSTEM

**3-155. GENERAL.**

This section provides procedures authorized at the organizational maintenance level to replace brake system components. To find a specific procedure contained in this section, see the task summary below.

<b>3-156. TASK SUMMARY.</b>		
<u>INITIAL SETUP</u>		
<u>APPLICABLE CONFIGURATIONS</u>	<u>EQUIPMENT CONDITION PARAGRAPH</u>	<u>CONDITION DESCRIPTION</u>
All.	(Refer to specific paragraph for this information).	
<u>TEST EQUIPMENT</u>		
Gage, air pressure, 0-200 psi.		
<u>SPECIAL TOOLS</u>		
None.		
<u>MATERIALS/PARTS (P/N)</u>		
Grease, automotive and artillery Item 7, Appendix C.		Pin, cotter (24617) 103395.
Rag, wiping Item 22, Appendix C.		Diaphragm (50153) 1133M009 (Front axle); (50153) 1126M009 (Rear axle).
Solvent, drycleaning, SD-2 Item 29, Appendix C.		Kit, seal (78330) 1069.
Seal, grease (2) (52304) 79903.		Pin, cotter (06853) 200981.
Tape, thread sealing Item 32, Appendix C.		Pin, cotter (06853) 210492.
Thread sealant, liquid Item 33, Appendix C.		Decal, locking positions, cab controlled fifth wheel (34623) 5995161 (if required).
Grease, silicone, lubrication Item 9, Appendix C.		Seal kit (06853) 287053.
Compound, thread locking Item 10, Appendix C.		Dehydrate cartridge assembly (06853) 286968.
Solution, soap Item 28, Appendix C.		Check valve repair kit (06853) 287298.
Pin, cotter (24617) 103395.		
Tie, cable (as required) (96906) MS 3367-7-9.		

**BRAKE SYSTEM.**

**3-156. TASK SUMMARY (Continued).**

INITIAL SETUP (Continued)

PERSONNEL REQUIRED

Two (MOS-63S).  
dirt and dust.

REFERENCES (TM)

TM 9-2320-238-10.  
TM 9-2320-283-20P.  
LO 9-2320-283-12.

SPECIAL ENVIRONMENTAL CONDITIONS

Work area clean and away from blowing

GENERAL SAFETY INSTRUCTIONS

Engine off.  
Transmission in neutral.  
Park brake set.  
Wheels blocked.  
Safety stand under axle.

TROUBLESHOOTING REFERENCES

Wear eye protection.  
Paragraph 2-11.

TASK NO.	TASK	LIST OF TASKS	TASK REF	TROUBLESHOOTING REF NO. (PARA)
1	Slack Adjuster Replacement	a. Removal.	3-157	2-11 3-157a
		b. Cleaning and Inspection.	3-157b	3-157c
		c. Installation.		3-157d
		d. Adjustment.		
2	Brake Assembly Replacement	a. Removal.	3-158	3-158a
		b. Installation.		3-158b
3	Brake Shoe Replacement	a. Removal.	3-159	2-11 3-159a
		b. Cleaning.		3-159b
		c. Inspection.		3-159c
		d. Installation.		3-159d
4	Camshaft and Camshaft Bracket Replacement	a. Removal.	3-160	2-11 3-160a
		b. Cleaning and Inspection.	3-160b	3-160c
		c. Installation.		

## BRAKE SYSTEM.

**3-156. TASK SUMMARY (Continued).**

## LIST OF TASKS

TASK NO.	TASK REF	TASK REF NO. (PARA)	TROUBLESHOOTING
5	Spider and Anchor Pin Replacement	3-161	2-11
	a. Removal.	3-161a	
	b. Cleaning and Inspection.	3-161b	
	c. Installation.	3-161c	
6	Dust Shield Replacement	3-162	
	a. Removal from Front Axle.	3-162a	
	b. Removal from Rear Tandem Axle.	3-162b	
	c. Cleaning and Inspection.	3-162c	
	d. Installation on Front Axle.	3-162d	
	e. Installation on Rear Tandem Axle.	3-162e	
7	Air Lines and Fittings Replacement	3-163	2-11
8	Front Axle and Rear-Rear Axle Brake Chamber Replacement	3-164	2-11
	a. Removal.	3-164a	
	b. Cleaning and Inspection.	3-164b	
	c. Installation.	3-164c	
	d. Operational Checkout.	3-164d	
9	Front Axle and Rear-Rear Axle Brake Chamber Repair	3-165	2-11
	a. Disassembly.	3-165a	
	b. Cleaning and Inspection.	3-165b	
	c. Assembly.	3-165c	
10	Forward-Rear Axle Brake Chamber Replacement	3-166	2-11
	a. Removal.	3-166a	
	b. Cleaning and Inspection.	3-166b	
	c. Installation.	3-166c	
11	Front External Air Couplings Replacement	3-167	2-11
	a. Right-Hand Couplings Removal.	3-167a	
	b. Left-Hand Couplings Removal.	3-167b	
	c. Left-Hand Couplings Installation.	3-167c	
	d. Right-Hand Couplings Installation.	3-167d	

## BRAKE SYSTEM.

**3-156. TASK SUMMARY (Continued).**

## LIST OF TASKS

TASK NO.REF	TASK REF NO. (PARA)	TASK	TROUBLESHOOTING
12	Supply Reservoir Replacement	3-168	2-11
	a. Removal.	3-168a	
	b. Installation.	3-168b	
13	Primary Reservoir Replacement	3-169	2-11
	a. Removal.	3-169a	
	b. Installation.	3-169b	
14	Secondary Reservoir Replacement	3-170	2-11
	a. Removal.	3-170a	
	b. Installation.	3-170b	
15	Park Brake Valve Replacement	3-171	
	a. Removal.	3-171a	
	b. Cleaning and Inspection.	3-171b	
	c. Installation.	3-171c	
16	Park Brake Valve Repair	3-172	- 2-11
	a. Disassembly.	3-172a	
	b. Cleaning and Inspection.	3-172b	
	c. Reassembly.	3-172c	
17	Trailer Hand Brake Valve Replacement	3-173	2-11
	a. Removal.	3-173a	
	b. Inspection.	3-173b	
	c. Installation.	3-173c	
	d. Operational Check.	3-173d	
	e. Adjustment.	3-173e	
18	Brake Treadle Valve Replacement	3-174	2-11
	a. Removal.	3-174a	
	b. Cleaning and Inspection.	3-174b	
	c. Installation.	3-174c	
19	Trailer Supply Valve Replacement	3-175	2-11
	a. Removal.	3-175a	
	b. Cleaning and Inspection.	3-175b	
	c. Installation.	3-175c	

## BRAKE SYSTEM.

**3-156. TASK SUMMARY (Continued).**

## LIST OF TASKS

TASK NO.REF	TASK REF NO. (PARA)	TASK	TROUBLESHOOTING
20	Trailer Supply Valve Repair a. Disassembly. b. Cleaning and Inspection. c. Reassembly.	3-176 3-176a 3-176b 3-176c	2-11
21	Relay Valve Replacement a. Removal. b. Cleaning and Inspection. c. Installation.	3-177 3-177a 3-177b 3-177c	2-11
22	Forward-Rear Axle Quick Release Valve Replacement a. Removal. b. Cleaning and Inspection. c. Installation.	3-178 3-178a 3-178b 3-178c	2-11
23	Rear-Rear Axle Quick Release Valve Replacement a. Removal. b. Cleaning and Inspection. c. Installation.	3-179 3-179a 3-179b 3-179c	2-11
24	Mountable Tee Replacement a. Right-Hand Main Rail Mountable Tee Replacement. b. Forward-Rear Axle Mountable Tee Replacement.	3-180 3-180a 3-180b	
25	Front Axle Ratio Valve Replacement a. Removal. b. Cleaning and Inspection. c. Installation.	3-181 3-181a 3-181b 3-181c	2-11
26	Double Check and Quick Release Valve Replacement a. Removal. b. Cleaning and Inspection. c. Installation.	3-182 3-182a 3-182b 3-182c	2-11



**BRAKE SYSTEM.****3-156. TASK SUMMARY (Continued).****LIST OF TASKS**

<b>Task No.</b>	<b>Task</b>	<b>Task Ref (Page)</b>	<b>Troubleshooting Ref No. (Page)</b>
27	Double Check and Stoplamp Valve Replacement a. Removal. b. Cleaning and Inspection. c. Installation.	3-183 3-183a 3-183b 3-183c	2-11
28	Firewall Double Check Valve Replacement a. Removal. b. Cleaning and Inspection. c. Installation.	3-184 3-184a 3-184b 3-184c	2-11
29	Secondary Reservoir Double Check Valve Replacement a. Removal. b. Cleaning and Inspection. c. Installation.	3-185 3-185a 3-185b 3-185c	2-11
30	Supply Reservoir Safety Valve Replacement a. Removal. b. Installation.	3-186 3-186a 3-186b	2-11
31	Secondary Reservoir Check Valve Replacement a. Removal. b. Installation.	3-187 3-187a 3-187b	2-11
32	Primary and Secondary Reservoir Draincock Replacement a. Removal. b. Inspection. c. Installation.	3-188 3-188a 3-188b 3-188c	2-11
33	Primary Reservoir Check Valve Replacement a. Removal. b. Installation.	3-189 3-189a 3-189b	2-11
	<b>3-913</b>		

**BRAKE SYSTEM.****3-156. TASK SUMMARY (Continued).****LIST OF TASKS**

<b>Task No.</b>	<b>Task</b>	<b>Task Ref (Page)</b>	<b>Troubleshooting Ref No. (Page)</b>
34	Supply Reservoir Drain Valve Replacement a. Removal. b. Cleaning and Inspection. c. Installation.	3-190 3-190a 3-190b 3-190c	2-11
35	Supply Reservoir Single Check Valve Replacement a. Removal. b. Cleaning and Inspection. c. Installation.	3-191 3-191a 3-191b 3-191c	2-11
36	Tractor Protection Valve Replacement a. Removal. b. Cleaning and Inspection. c. Installation.	3-192 3-192a 3-192b 3-192c	2-11
37	Brake Pedal Double Check Valve Replacement a. Removal. b. Cleaning and Inspection. c. Installation.	3-1932-11 3-193a 3-193b 3-193c	
38	Fifth Wheel Toggle Valve Replacement a. Removal. b. Cleaning and Inspection. c. Installation.	3-194 3-194a 3-194b 3-194c	2-11
39	Differential Toggle Valve Replacement a. Removal. b. Cleaning and Inspection. c. Installation.	3-195 3-195a 3-195b 3-195c	2-11
	<b>3-914</b>		

**BRAKE SYSTEM.****3-156. TASK SUMMARY (Continued).****LIST OF TASKS**

<b>Task No.</b>	<b>Task</b>	<b>Task Ref (Page)</b>	<b>Troubleshooting Ref No. (Page)</b>
40	Trailer Couplings, Brackets, and Hose Replacement a. Front Couplings and Hose Removal. b. Rear Couplings and Brackets Removal.3-196b c. Rear Couplings and Brackets Installation.3-196c d. Front Couplings and Hose Installation.	3-196 3-196a  3-196d	2-11
41	Hose Tender Replacement a. Removal. b. Installation.	3-197 3-197a 3-197b	
42	Air Dryer Replacement a. Removal. b. Cleaning and Inspection. c. Installation. d. Operational Check.	3-198 3-198a 3-198b 3-198c 3-198d	2-11
43	Air Dryer Repair a. Disassembly. b. Cleaning. c. Inspection. d. Repair. e. Assembly.	3-199 3-199a 3-199b 3-199c 3-199d 3-199e	2-11
44	Air Dryer Dehydrate Cartridge Replacement a. Removal. b. Cleaning. c. Inspection. d. Lubrication. e. Installation.	3-200 3-200a 3-200b 3-200c 3-200d 3-200e	2-11
		<b>3-915</b>	

**BRAKE SYSTEM.**

3-157. SLACK ADJUSTER REPLACEMENT.

THIS TASK COVERS

- a. Removal.
- b. Cleaning and Inspection.
- c. Installation.
- d. Adjustment

INITIAL SETUP

APPLICABLE CONFIGURATIONS

All.

TEST EQUIPMENT

None.

SPECIAL TOOLS

None.

MATERIALS/PARTS (P/N)

Grease, automotive and artillery  
Item 7, Appendix C.  
Rag, wiping  
Item 22, Appendix C.  
Solvent, dry-cleaning, SD-2  
Item 29, Appendix C.  
Pin, cotter  
(24617) 103395.

PERSONNEL REQUIRED

Two (MOS-63S).

REFERENCES (TM)

TM 9-2320-283-10.  
TM 9-2320-283-20P.

TROUBLESHOOTING REFERENCES

Paragraph 2-11.

EQUIPMENT CONDITION

PARAGRAPH

Forward-Rear Axle  
only:

TM 9-2320-283-10.

CONDITION DESCRIPTION

Parking brake released  
or spring brake power  
springs manually  
compressed.

SPECIAL ENVIRONMENTAL CONDITIONS

None.

GENERAL SAFETY INSTRUCTIONS

Engine off.  
Transmission in neutral.  
Wheels blocked.

**BRAKE SYSTEM.**

**3-157. SLACK ADJUSTER REPLACEMENT (Continued).**

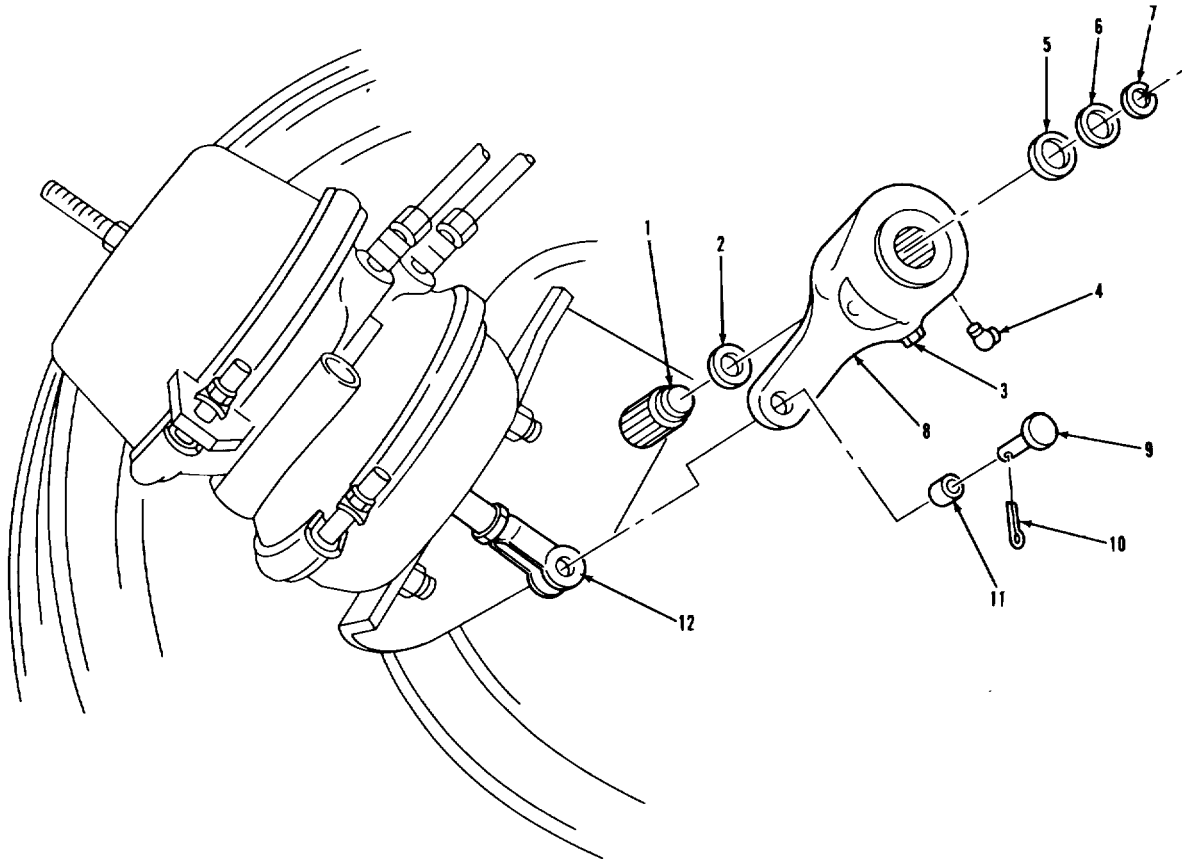

**LEGEND:**

- |                        |                            |
|------------------------|----------------------------|
| 1. CAMSHAFT            | 7. SNAPRING                |
| 2. WASHER              | 8. SLACK ADJUSTER          |
| 3. ADJUSTING SCREW     | 9. CLEVIS PIN              |
| 4. LUBRICATION FITTING | 10. COTTER PIN             |
| 5. WASHER SHIM         | 11. SLACK ADJUSTER BUSHING |
| 6. WASHER SHIM         | 12. CLEVIS                 |

**BRAKE SYSTEM.**

3-157. SLACK ADJUSTER REPLACEMENT (Continued).		
LOCATION/ITEM	ACTION	REMARKS
<p><b>NOTE</b></p> <ul style="list-style-type: none"> <li>• Replacement and adjustment of the six slack adjusters is the same.</li> <li>• Always adjust both slack adjusters on an axle.</li> </ul>		
<b>A. <u>REMOVAL.</u></b>		
1. Pin (10).	Remove from item (9).	Discard item (10).
2. Pin (9).	Remove from item (12) and item (11).	
3. Screw (3).	Press and turn until item (8) is clear of item (12).	
4. Snap-ring (7), shim (5), shim (6), slack adjuster (8), and washer (2).	Remove from item (1).	
5. Fitting (4).Remove from item (8).		
<p><b>NOTE</b></p> <p><b>Do not remove bushing except to replace with a new one.</b></p>		
6. Bushing (11).	Press from item (8).Discard item (11).	
<b>B. <u>CLEANING AND INSPECTION.</u></b>		
7. Slack adjuster (8).	Wipe clean with solvent soaked rag.	
8. All parts except slack adjuster (8).	Clean with solvent.	Refer to paragraph 3-4.
9. All parts.	Inspect.	Refer to paragraph 3-5.
<b>3-918</b>		

**BRAKE SYSTEM.**

**3-157. SLACK ADJUSTER REPLACEMENT (Continued).**

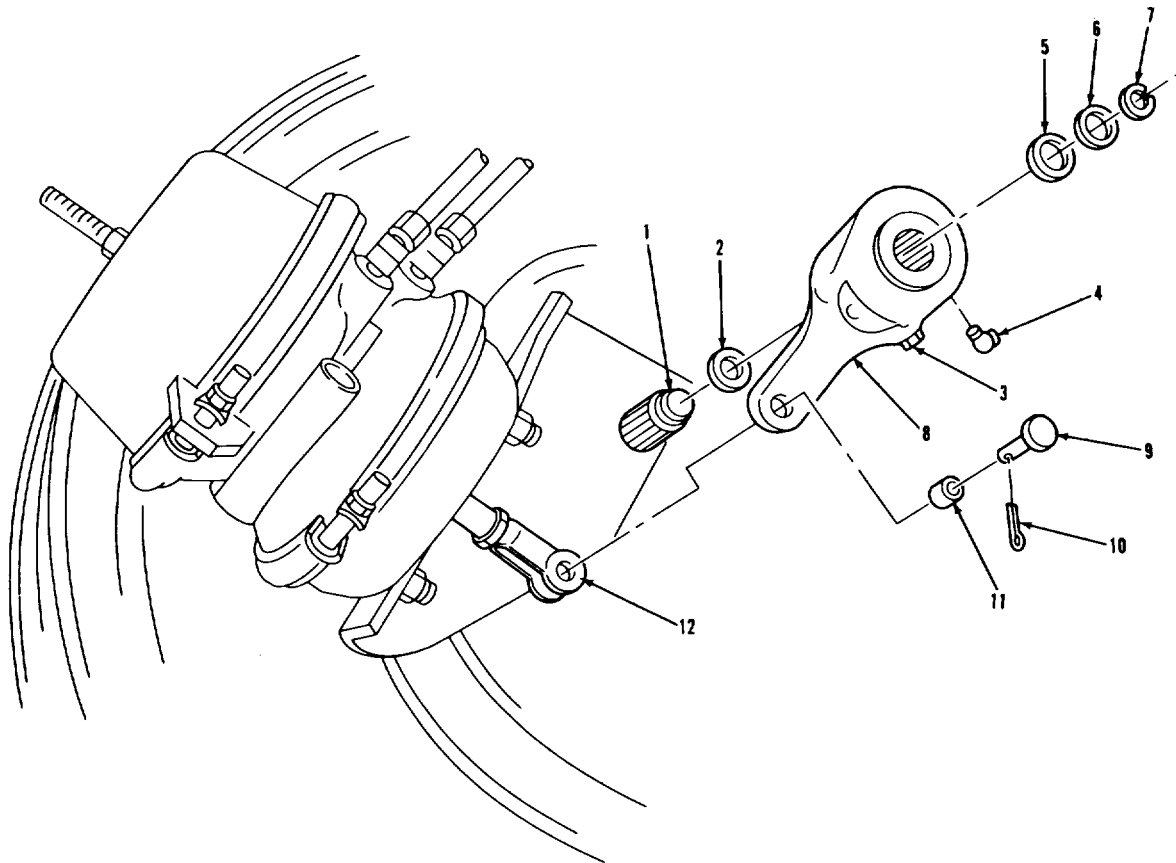

**LEGEND:**

- |                        |                            |
|------------------------|----------------------------|
| 1. CAMSHAFT            | 7. SNAPRING                |
| 2. WASHER              | 8. SLACK ADJUSTER          |
| 3. ADJUSTING SCREW     | 9. CLEVIS PIN              |
| 4. LUBRICATION FITTING | 10. COTTER PIN             |
| 5. WASHER SHIM         | 11. SLACK ADJUSTER BUSHING |
| 6. WASHER SHIM         | 12. CLEVIS                 |

TA 237425

**BRAKE SYSTEM.**

3-157. SLACK ADJSUTER REPLACEMENT (Continued)		
LOCATION/ITEM	ACTION	REMARKS
<b>C. <u>INSTALLATION.</u></b>		
10. New bushing (11).	Press in item (8).	
11. Fitting (4).	a. Install in item (8). b. Fill with grease.	
12. Camshaft (1).	Apply thin coat of grease.	
13. Washer (2), slack adjuster (8), shim (6), shim (5), and snap-ring (7).	Install on item (1).	
14. Screw (3).	Press and turn until item (9) can be installed in items (12) and (8).	
15. Pin (9).	Install in item (12) and (8).	
16. New pin (10).	Install in item (9).	
<b>D. <u>ADJUSTMENT.</u></b>		
17. Wheel.	Raise off ground.	Refer to TM 9-2320-283-10.
18. Screw (3).	a. Press in and turn until wheel will not rotate. b. Back off one quarter turn.	Check to see that wheel rotates freely with no drag and that there is 3/4 inch to 1 inch push rod travel.
19. Wheel.		
19. Wheel.	Lower to ground.	
<p><b>NOTE</b>  <b>Follow-on maintenance action required:</b>  <b>Manually release the spring brake power spring and set park brake (TM 9-2320-283-10).</b></p>		
<p><b>3-920</b></p>		



**BRAKE SYSTEM.**

**3-157. SLACK ADJUSTER REPLACEMENT (Continued).**

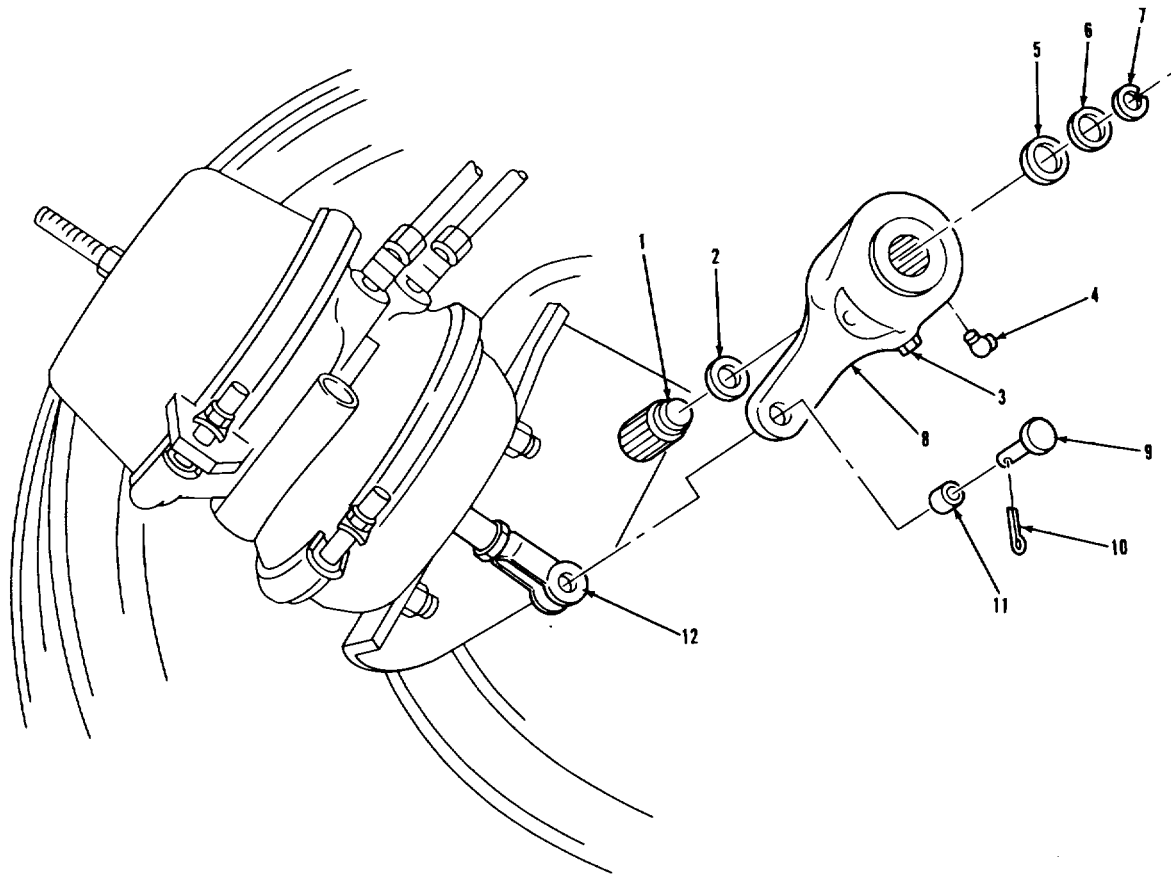

**LEGEND:**

- |                        |                            |
|------------------------|----------------------------|
| 1. CAMSHAFT            | 7. SNAPRING                |
| 2. WASHER              | 8. SLACK ADJUSTER          |
| 3. ADJUSTING SCREW     | 9. CLEVIS PIN              |
| 4. LUBRICATION FITTING | 10. COTTER PIN             |
| 5. WASHER SHIM         | 11. SLACK ADJUSTER BUSHING |
| 6. WASHER SHIM         | 12. CLEVIS                 |

**BRAKE SYSTEM.**

**3-158. BRAKE ASSEMBLY REPLACEMENT.**

THIS TASK COVERS

- a. Removal.
- b. Installation.

INITIAL SETUP

APPLICABLE CONFIGURATIONS

All.

TEST EQUIPMENT

None.

SPECIAL TOOLS

None.

MATERIALS/PARTS (P/N)

None.

PERSONNEL REQUIRED

Two (MOS-63S).

REFERENCES (TM)

TM 9-2320-283-10.

TROUBLESHOOTING REFERENCES

None.

EQUIPMENT CONDITION

PARAGRAPH

TM 9-2320-283-10.

Front axle only:

3-204.

3-205.

Rear axle only:

3-154.

3-206.

3-207.

SPECIAL ENVIRONMENTAL CONDITIONS

None.

GENERAL SAFETY INSTRUCTIONS

Engine off.

Transmission in neutral.

Park brake set.

Wheels blocked.

CONDITION DESCRIPTION

Wheel(s) removed.

Front drum removed.

Front hub, bearings,  
and seals removed.

Rear axle shaft  
removed.

Rear brake drum  
removed.

Rear hub, bearings, and  
seals removed.

**BRAKE SYSTEM.**

**3-158. BRAKE ASSEMBLY REPLACEMENT (Continued).**

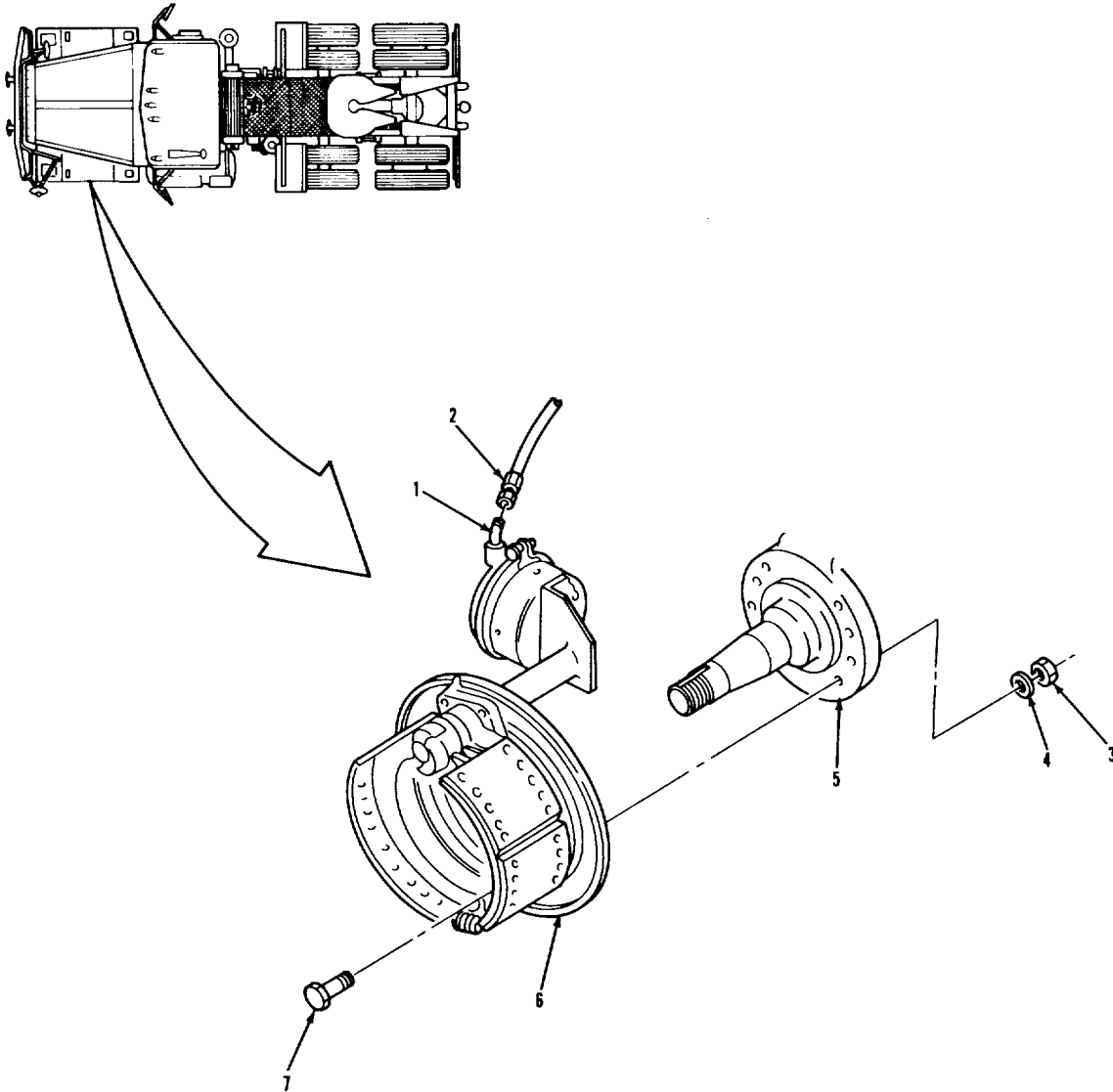

**LEGEND:**

- |                        |                           |
|------------------------|---------------------------|
| 1. ELBOW               | 5. AXLE ASSEMBLY          |
| 2. HOSE ASSEMBLY       | 6. SERVICE BRAKE ASSEMBLY |
| 3. HEX NUT (8)         | 7. SCREW (8)              |
| 4. HARDENED WASHER (8) |                           |

**BRAKE SYSTEM.**

3-158. BRAKE ASSEMBLY REPLACEMENT (Continued)		
LOCATION/ITEM	ACTION	REMARKS
<p><b>NOTE</b>                      Replacement of the six brake assemblies is similar. Left front is shown.</p>		
<b>A. REMOVAL.</b>		
1. Hose assembly (2).	Remove from item (1).	
2. Eight screws (7), washers (4), and nuts (3).	Remove from item (6).	
3. Brake assembly (6) mechanic.	Remove from item (5).	Assistant helps
<p><b>NOTE</b>                      Only do steps 4 and 5 to replace brake assembly with a new one.</p>		
4. Brake chamber.	Remove.	Refer to paragraphs 3-164 and 3-165.
5. Slack adjuster.	Remove.	Refer to paragraph 3-157.
<b>B. INSTALLATION.</b>		
6. Brake assembly (6).	Put in place on item (5).	Assistant helps mechanic.
7. Eight screws (7), washers (4), and nuts (3).	Secure item (6) to item (5).	Torque between 90 and 100 lb.-ft.
8. Hose assembly (2).	Install on item (1).	
<b>3-924</b>		

**BRAKE SYSTEM.**

**3-158. BRAKE ASSEMBLY REPLACEMENT (Continued).**

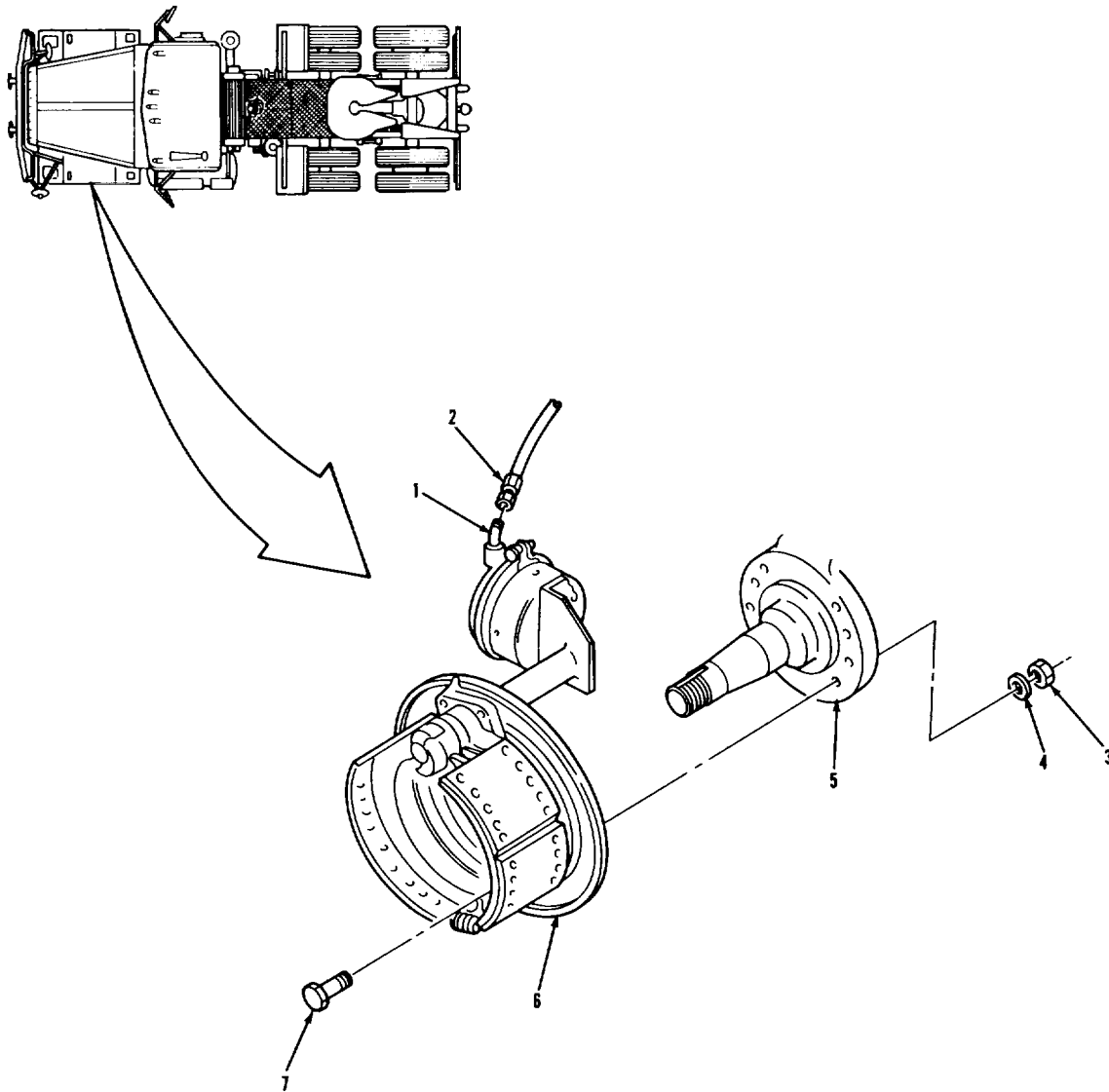

**LEGEND:**

- |                        |                           |
|------------------------|---------------------------|
| 1. ELBOW               | 5. AXLE ASSEMBLY          |
| 2. HOSE ASSEMBLY       | 6. SERVICE BRAKE ASSEMBLY |
| 3. HEX NUT (8)         | 7. SCREW (8)              |
| 4. HARDENED WASHER (8) |                           |

**BRAKE SYSTEM.**

3-158. BRAKE ASSEMBLY REPLACEMENT (Continued)		
LOCATION/ITEM	ACTION	REMARKS
	<p><b>NOTE</b></p> <p><b>Follow-on maintenance action required:</b></p> <p>Front axle only:</p> <p>Install front hub, bearings, and seals (para 3-205). Install front drum (para 3-204).</p> <p>Rear axle only:</p> <p>Install rear hub, bearings, and seals (para 3-207). Install rear brake drum (para 3-206). Install rear axle shaft (para 3-154).</p> <p>Both front and rear axle:</p> <p>Install wheel (TM 9-2320-283-10). Install slack adjuster (para 3-157). Install brake chamber (para 3-164 or 3-166).</p> <p style="text-align: center;"><b>3-926</b></p>	

**BRAKE SYSTEM.**

**3-158. BRAKE ASSEMBLY REPLACEMENT (Continued).**

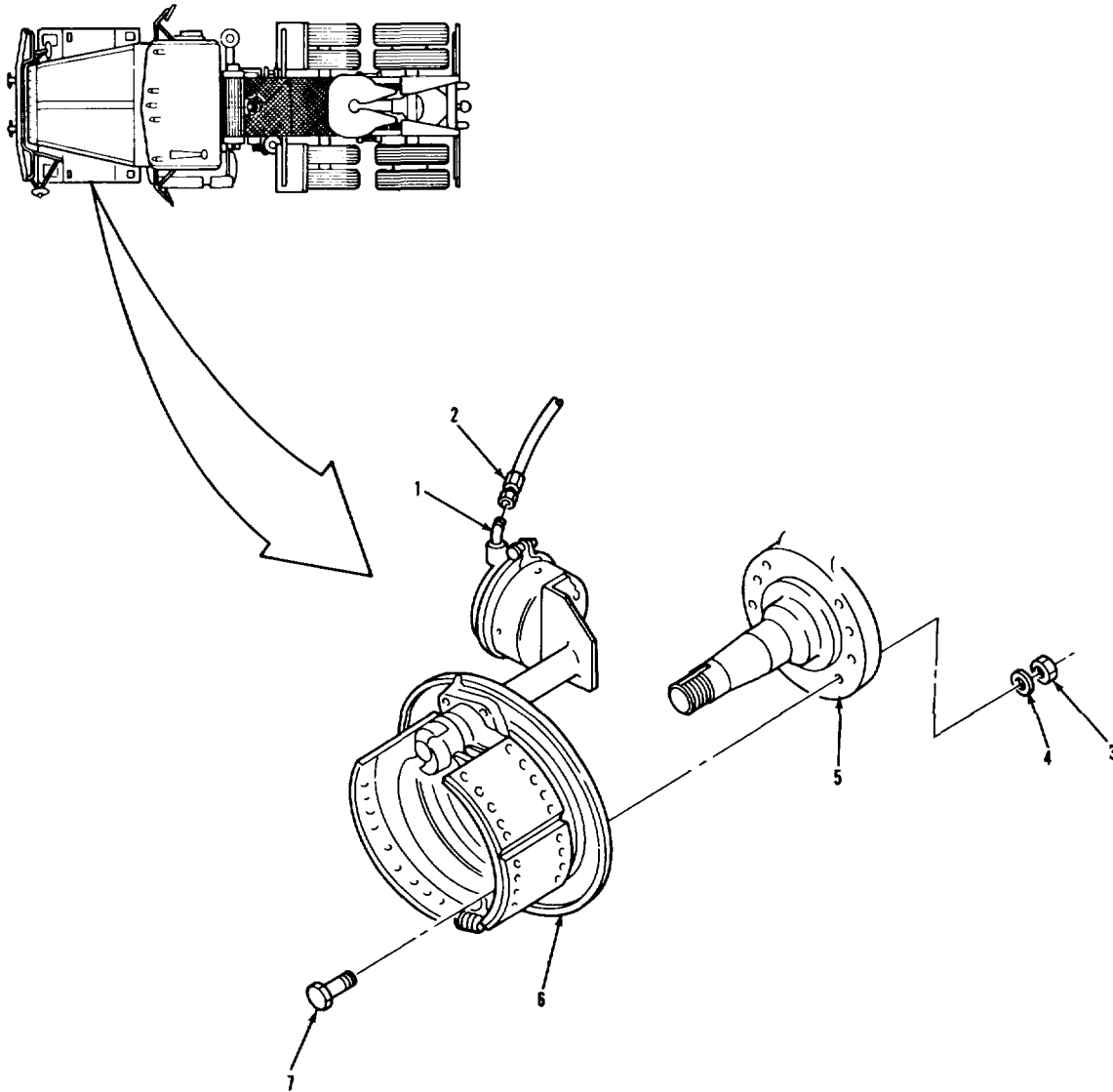

**LEGEND:**

- |                        |                           |
|------------------------|---------------------------|
| 1. ELBOW               | 5. AXLE ASSEMBLY          |
| 2. HOSE ASSEMBLY       | 6. SERVICE BRAKE ASSEMBLY |
| 3. HEX NUT (8)         | 7. SCREW (8)              |
| 4. HARDENED WASHER (8) |                           |

**BRAKE SYSTEM.**

**3-159. BRAKE SHOE REPLACEMENT.**

THIS TASK COVERS

- a. Removal.
- b. Cleaning.
- c. Inspection.
- d. Installation.

INITIAL SETUP

APPLICABLE CONFIGURATIONS

All.

EQUIPMENT CONDITION  
PARAGRAPH

3-204 or 3-206.

CONDITION DESCRIPTION

Brake drum removed.

TEST EQUIPMENT

None.

SPECIAL TOOLS

None.

MATERIALS/PARTS (P/N)

Rag, wiping  
Item 22, Appendix C.

PERSONNEL REQUIRED

One (MOS-63S).

SPECIAL ENVIRONMENTAL CONDITIONS

None.

REFERENCES (TM)

TM 9-2320-283-10.

GENERAL SAFETY INSTRUCTIONS

Engine off.  
Transmission in neutral.  
Wheels blocked.  
Safety stand under axle.

TROUBLESHOOTING REFERENCES

Paragraph 2-11.



**BRAKE SYSTEM.**

**3-159. BRAKE SHOE REPLACEMENT (Continued).**

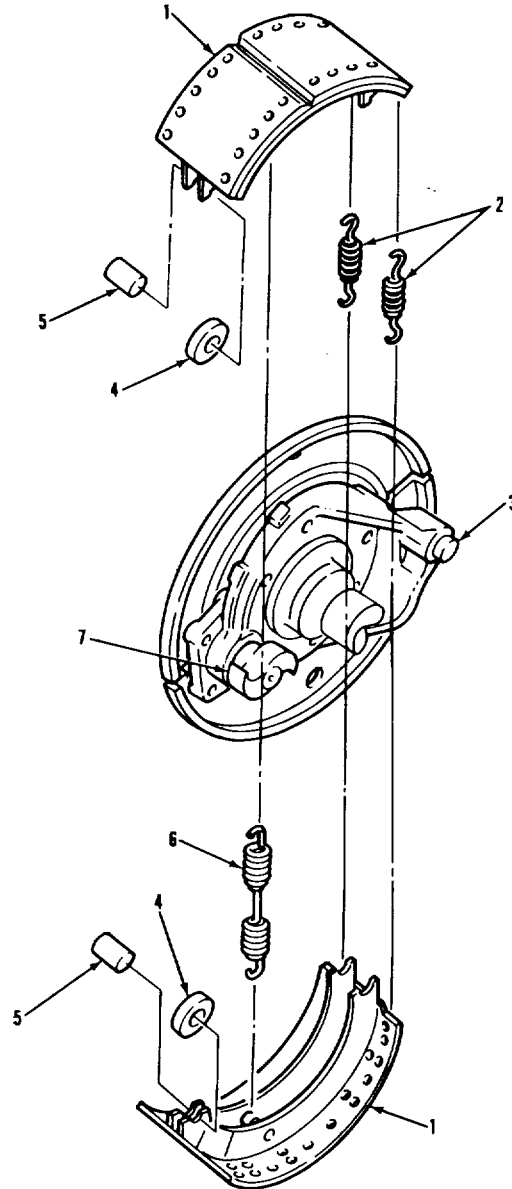

**LEGEND:**

- |                                   |                        |
|-----------------------------------|------------------------|
| 1. SHOE AND LINING ASSEMBLY (2)   | 5. CAM ROLLER PIN (2)  |
| 2. SHOE RETAINING SPRING (2)      | 6. SHOE RELEASE SPRING |
| 3. SPIDER AND ANCHOR PIN ASSEMBLY | 7. CAMSHAFT            |
| 4. CAM ROLLER (2)                 |                        |

**BRAKE SYSTEM.**

3-159. BRAKE SHOE REPLACEMENT (Continued)		
LOCATION/ITEM	ACTION	REMARKS
<b>NOTE</b>		
<ul style="list-style-type: none"> <li>• Replacement of the twelve brake shoes is the same.</li> <li>• Always replace all four brake shoes on an axle.</li> </ul>		
<b>A. REMOVAL.</b>		
1. Two pins (5) and rollers (4).	Remove.	Use screwdriver to pry items (1) out of the way.
2. Spring (6).	Remove.	
3. Two shoe and lining assemblies (1) and springs (2).	Remove.	
<b>B. CLEANING.</b>		
4. All parts.	Clean with water and rags.	
<b>C. INSPECTION.</b>		
5. Two shoe and lining assemblies (1).	<ul style="list-style-type: none"> <li>a. Measure thickness of lining material.</li> <li>b. Inspect for cracked, chipped, broken, or bent surface.</li> </ul>	Replace if less than 5/16-inch. If damaged, refer to DS/GS maintenance for repair.
6. Camshaft (7).	Inspect for looseness, cracks, breaks, or other damage.	If damaged, refer to paragraph 3-160.
7. Spring (6), two pins (5), springs (2), and rollers (4).	Inspect.	Refer to paragraph 3-5.
8. Spider and pin assembly (3). damage.	Inspect for looseness, cracks, breaks, and other	If damaged, refer to paragraph 3-161.
<b>3-930</b>		

**BRAKE SYSTEM.**

**3-159. BRAKE SHOE REPLACEMENT (Continued).**

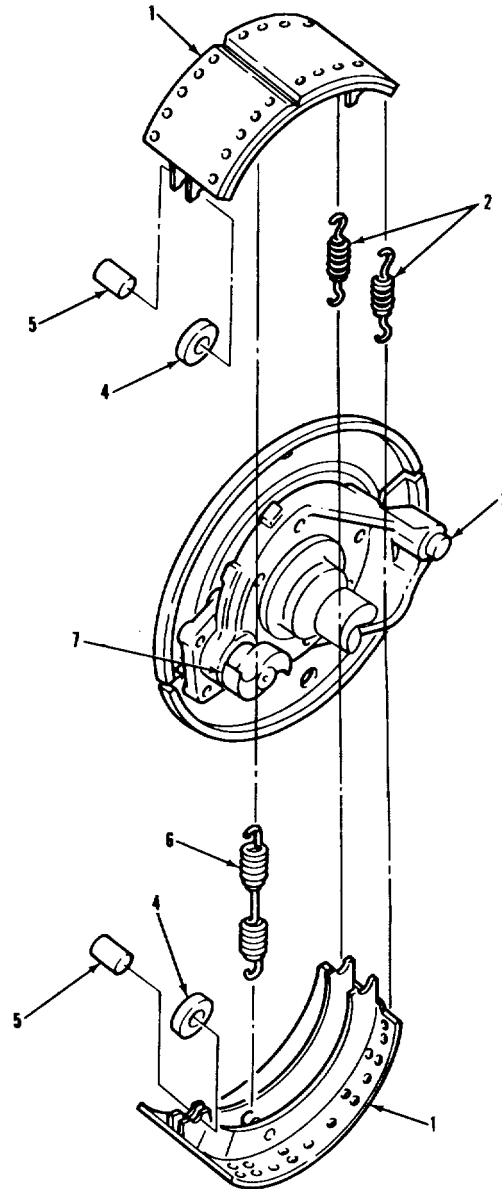

**LEGEND:**

- |                                   |                        |
|-----------------------------------|------------------------|
| 1. SHOE AND LINING ASSEMBLY (2)   | 5. CAM ROLLER PIN (2)  |
| 2. SHOE RETAINING SPRING (2)      | 6. SHOE RELEASE SPRING |
| 3. SPIDER AND ANCHOR PIN ASSEMBLY | 7. CAMSHAFT            |
| 4. CAM ROLLER (2)                 |                        |

**BRAKE SYSTEM.**

3-159. BRAKE SHOE REPLACEMENT (Continued)		
LOCATION/ITEM	ACTION	REMARKS
<b>D. <u>INSTALLATION.</u></b>		
9. Two shoe and lining assemblies (1) and spring (2).	Install on item (3).	
10. Spring (6).	Install on two items (1).	
11. Two pins (5) and rollers (4).	Install on two items (1) and item (7).	Pry items (1) with screwdriver.
<p><b>NOTE</b>  <b>Follow-on maintenance action required:</b>  <b>Install brake drum (para 3-204 or para 3-206).</b>  <b>Adjust slack adjusters (para 3-157).</b></p>		
<p><b>3-932</b></p>		

**BRAKE SYSTEM.**

**3-159. BRAKE SHOE REPLACEMENT (Continued).**

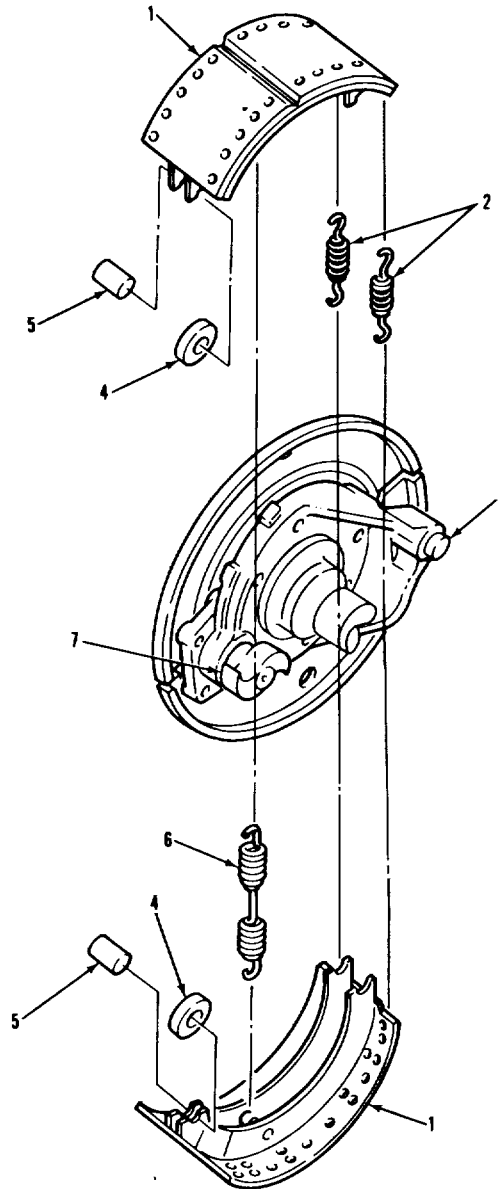

**LEGEND:**

- |                                   |                        |
|-----------------------------------|------------------------|
| 1. SHOE AND LINING ASSEMBLY (2)   | 5. CAM ROLLER PIN (2)  |
| 2. SHOE RETAINING SPRING (2)      | 6. SHOE RELEASE SPRING |
| 3. SPIDER AND ANCHOR PIN ASSEMBLY | 7. CAMSHAFT            |
| 4. CAM ROLLER (2)                 |                        |

**BRAKE SYSTEM.****3-160. CAMSHAFT AND CAMSHAFT BRACKET REPLACEMENT.**THIS TASK COVERS

- a. Removal.
- b. Cleaning and Inspection.
- c. Installation.

INITIAL SETUPAPPLICABLE CONFIGURATIONS

All.

TEST EQUIPMENT

None.

SPECIAL TOOLS

None.

MATERIALS/PARTS (P/N)

Grease, automotive and artillery  
 Item 7, Appendix C.  
 Seal, grease (2)  
 (52304) 79903.

PERSONNEL REQUIRED

One (MOS-63S).

REFERENCES (TM)

TM 9-2320-283-20P.

TROUBLESHOOTING REFERENCES

Paragraph 2-11.

EQUIPMENT CONDITION  
PARAGRAPH

3-159.

3-164 or 3-166.

3-157.

CONDITION DESCRIPTION

Brake shoes removed.

Brake chamber removed.

Slack adjuster removed.

SPECIAL ENVIRONMENTAL CONDITIONS

None.

GENERAL SAFETY INSTRUCTIONS

Engine off.  
 Transmission in neutral.  
 Wheels blocked.  
 Safety stand under axle.

**BRAKE SYSTEM.**

**3-160. CAMSHAFT AND CAMSHAFT BRACKET REPLACEMENT (Continued).**

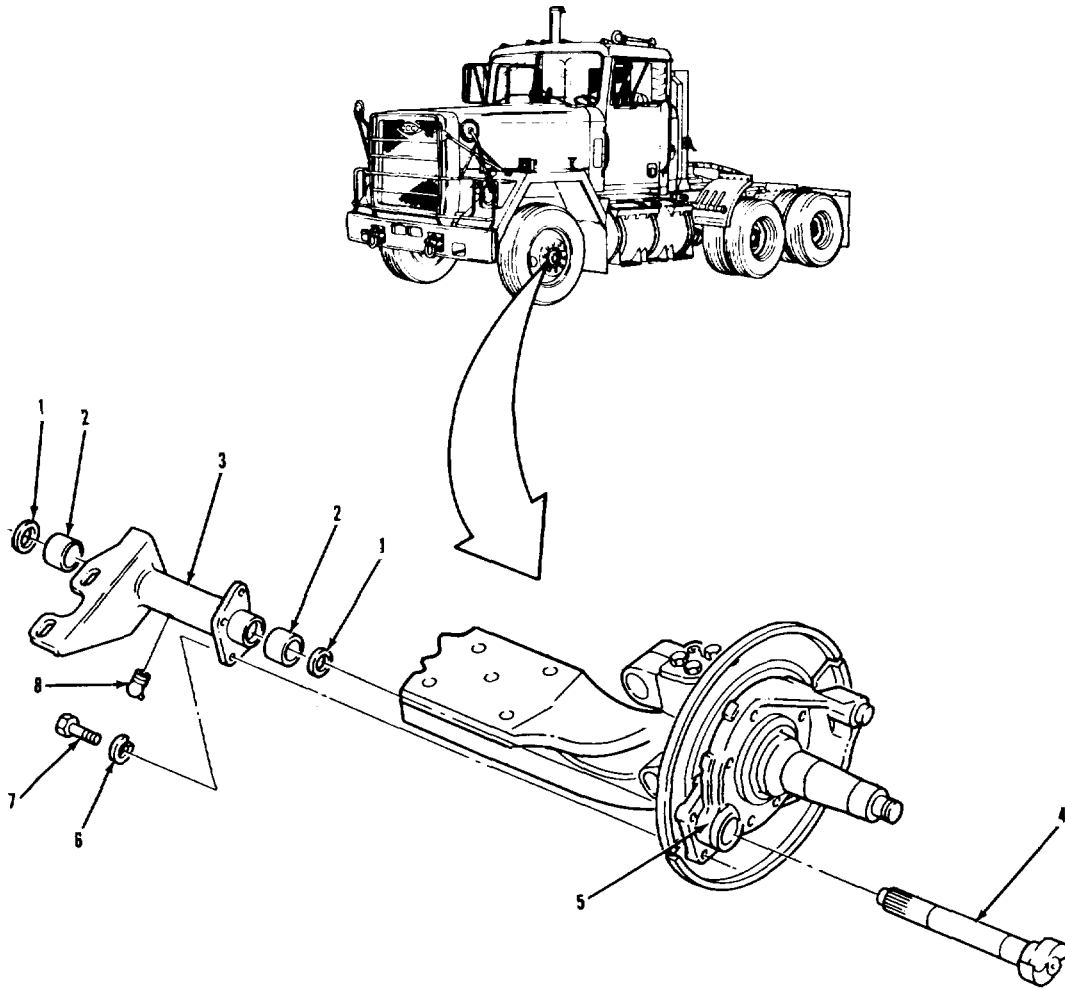

**LEGEND:**

- |                              |                                   |
|------------------------------|-----------------------------------|
| 1. GREASE SEAL (2)           | 5. SPIDER AND ANCHOR PIN ASSEMBLY |
| 2. BUSHING (2)               | 6. LOCKWASHER (4)                 |
| 3. CAMSHAFT BRACKET ASSEMBLY | 7. HEXAGON HEAD SCREW (4)         |
| 4. CAMSHAFT                  | 8. LUBRICATION FITTING            |

**BRAKE SYSTEM.**

3-160. CAMSHAFT AND CAMSHAFT BRACKET REPLACEMENT (Continued)		
LOCATION/ITEM	ACTION	REMARKS
<p><b>NOTE</b>                      Replacement of the six camshafts and brackets is similar. Replacement of left front is shown. Nuts are used in place of screws (7) for rear camshaft brackets.</p>		
<b>A. <u>REMOVAL.</u></b>		
1. Camshaft (4).	Remove from item (5) and item (3).	
2. Four screws (7) (nuts (7) for rear bracket) and lockwashers (6).	Remove from item (3) and item (5).	
3. Bracket assembly (3).	Remove from item (5).	
4. Fitting (8).	Remove from item (3).	
5. Two seals (1).	Pry from item (3).	Discard two items (1).
<p><b>NOTE</b>                      Do not remove bushings, except to replace with new ones.</p>		
6. Two bushings (2).	Remove from item (3).	a. Use a hammer and punch. b. Discard two items (2).
<b>B. <u>CLEANING AND INSPECTION.</u></b>		
7. All parts and 3-5.	Clean and inspect.	Refer to paragraphs 3-4
<b>3-936</b>		



**BRAKE SYSTEM.**

**3-160. CAMSHAFT AND CAMSHAFT BRACKET REPLACEMENT (Continued).**

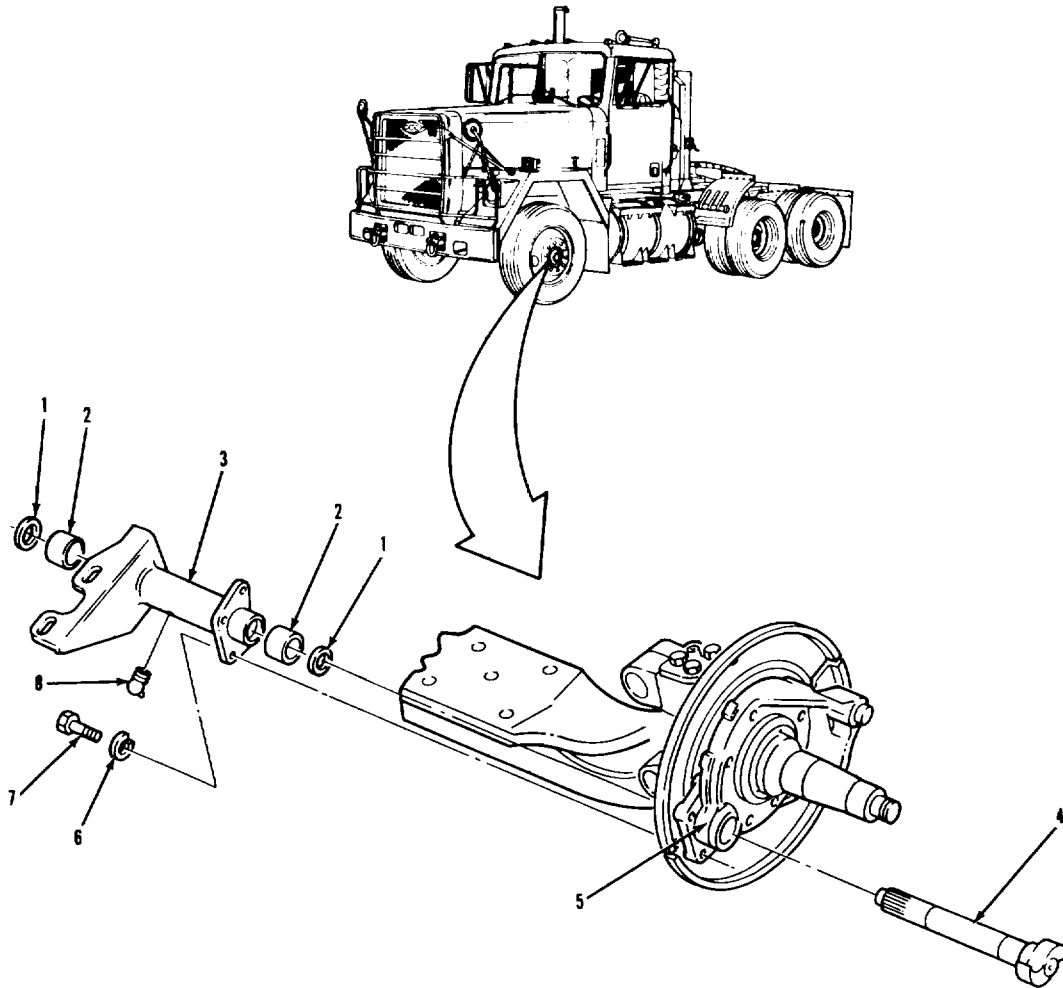

**LEGEND:**

- |                              |                                   |
|------------------------------|-----------------------------------|
| 1. GREASE SEAL (2)           | 5. SPIDER AND ANCHOR PIN ASSEMBLY |
| 2. BUSHING (2)               | 6. LOCKWASHER (4)                 |
| 3. CAMSHAFT BRACKET ASSEMBLY | 7. HEXAGON HEAD SCREW (4)         |
| 4. CAMSHAFT                  | 8. LUBRICATION FITTING            |

**BRAKE SYSTEM.**

<b>3-160. CAMSHAFT AND CAMSHAFT BRACKET REPLACEMENT (Continued)</b>		
<b>LOCATION/ITEM</b>	<b>ACTION</b>	<b>REMARKS</b>
<b>C. <u>INSTALLATION.</u></b>		
8. Two new bushings (2).	Press into item (3).	
9. Two new seals (1).	Press into item (3).	Install so that rubber part of item (1) will face away from vehicle.
10. Bracket assembly (3).	Install in item (5).	
11. Four screws (7) (nuts (7) for rear bracket) and lockwashers (6).	Secure item (3) to item (5).	
12. Camshaft (4). Install in item (5) and item (3).		
13. Fitting (8).	a. Install in item (3). b. Fill with grease.	
<p><b>NOTE</b></p> <p><b>Follow-on maintenance action required:</b></p> <p><b>Install brake shoes (para 3-159).</b></p> <p><b>Install brake chamber (para 3-164 or 3-166).</b></p> <p><b>Install slack adjuster (para 3-157).</b></p>		
<p><b>3-938</b></p>		

**BRAKE SYSTEM.**

**3-160. CAMSHAFT AND CAMSHAFT BRACKET REPLACEMENT (Continued).**

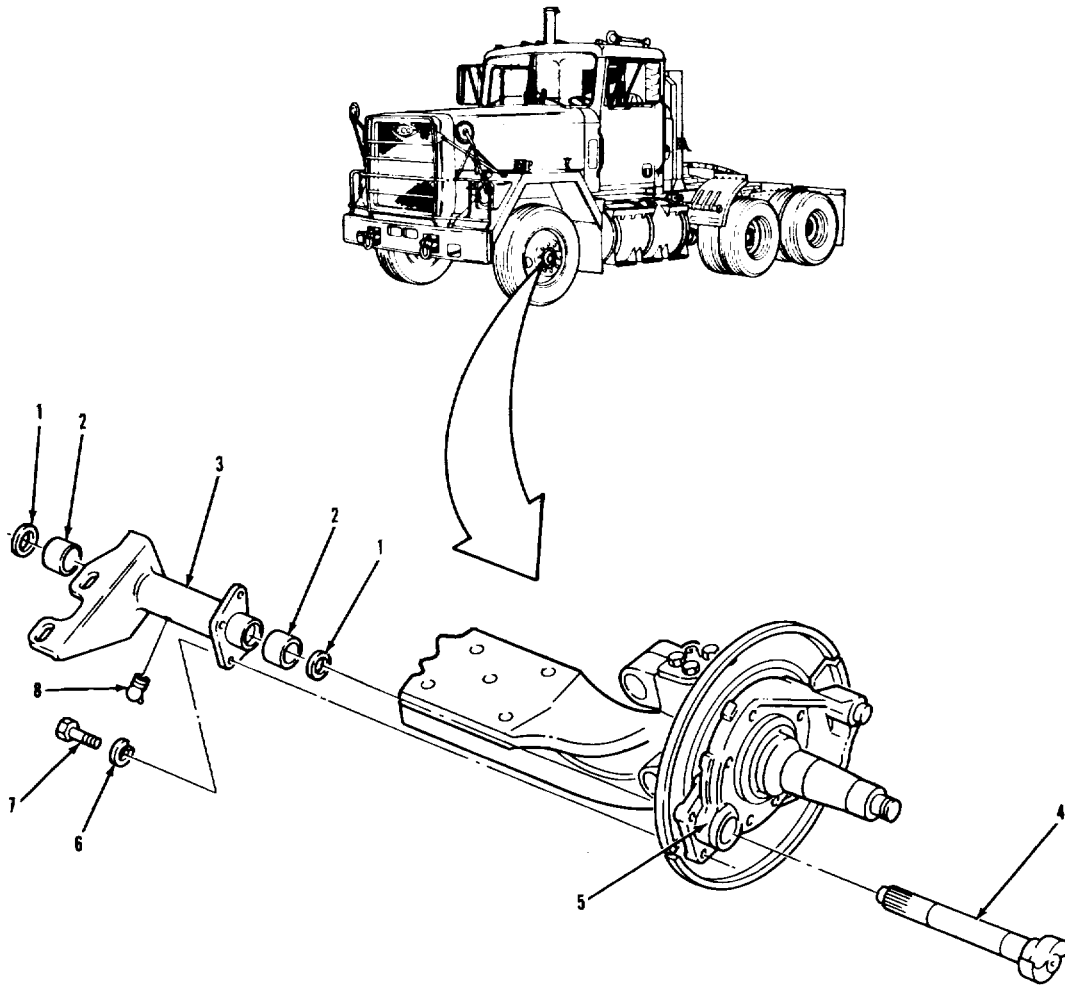

**LEGEND:**

- |                              |                                   |
|------------------------------|-----------------------------------|
| 1. GREASE SEAL (2)           | 5. SPIDER AND ANCHOR PIN ASSEMBLY |
| 2. BUSHING (2)               | 6. LOCKWASHER (4)                 |
| 3. CAMSHAFT BRACKET ASSEMBLY | 7. HEXAGON HEAD SCREW (4)         |
| 4. CAMSHAFT                  | 8. LUBRICATION FITTING            |

**BRAKE SYSTEM.**

**3-161. SPIDER AND ANCHOR PIN REPLACEMENT.**

THIS TASK COVERS

- a. Removal.
- b. Cleaning and Inspection.
- c. Installation.

INITIAL SETUP

APPLICABLE CONFIGURATIONS

All.

EQUIPMENT CONDITION  
PARAGRAPH

3-160.

CONDITION DESCRIPTION

Camshaft and camshaft  
bracket removed.

TEST EQUIPMENT

None.

3-162.

Dust shields removed.

SPECIAL TOOLS

None.

MATERIALS/PARTS (P/N)

None.

PERSONNEL REQUIRED

One (MOS-63S).

SPECIAL ENVIRONMENTAL CONDITIONS

None.

REFERENCES (TM)

None.

GENERAL SAFETY INSTRUCTIONS

Engine off.  
Transmission set in neutral.  
Wheels blocked.

TROUBLESHOOTING REFERENCES

Paragraph 2-11.

Safety stand under axle.

**3-940**

**BRAKE SYSTEM.**

**3-161. SPIDER AND ANCHOR PIN REPLACEMENT (Continued).**

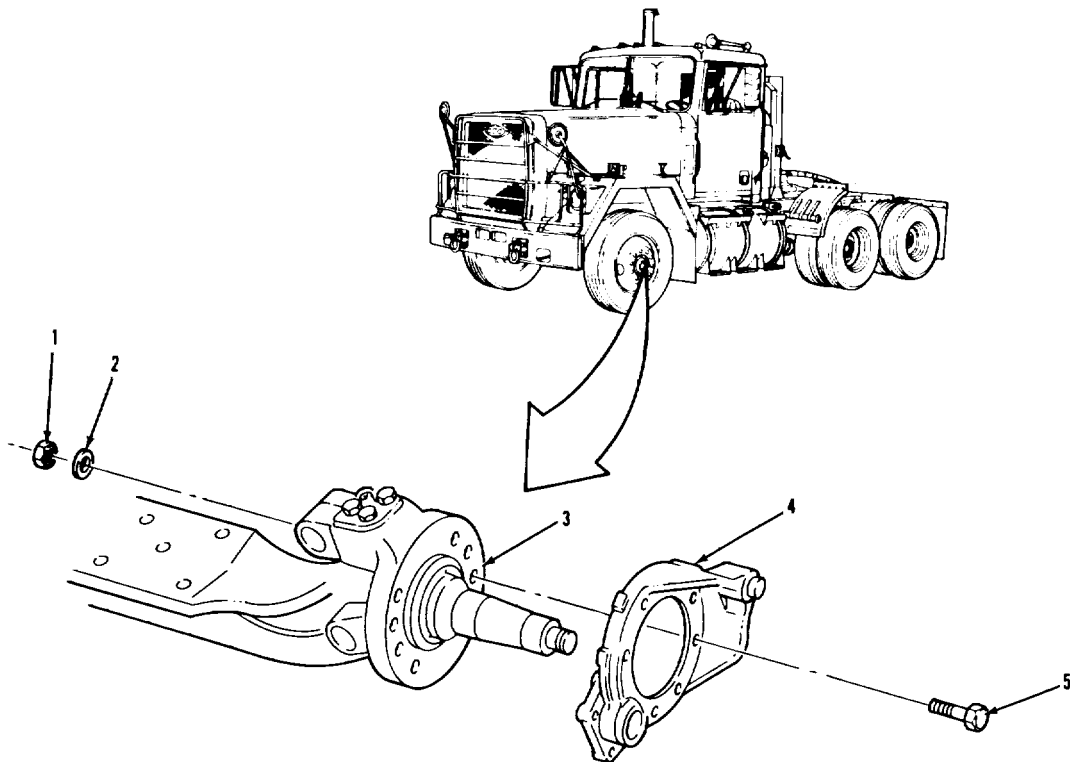

**LEGEND:**

- |                        |                                   |
|------------------------|-----------------------------------|
| 1. HEXAGON NUT (8)     | 4. SPIDER AND ANCHOR PIN ASSEMBLY |
| 2. HARDENED WASHER (8) | 5. HEXAGON HEAD SCREW (8)         |
| 3. AXLE ASSEMBLY       |                                   |

**BRAKE SYSTEM.**

3-161. SPIDER AND ANCHOR PIN REPLACEMENT		
LOCATION/ITEM	ACTION	REMARKS
<p><b>A. <u>REMOVAL.</u></b></p>		
<p><b>NOTE</b></p> <p><b>Replacement of the six spider and anchor pins is the same. Replacement of left front is shown.</b></p>		
1. Eight screws (5), washers (2), and nuts (1).	Remove from item (4).	
<p><b>B. <u>CLEANING AND INSPECTION.</u></b></p>		
2. All parts.	Clean and inspect.	Refer to paragraphs 3-4 and 3-5.
<p><b>C. <u>INSTALLATION.</u></b></p>		
4. Spider and pin assembly (4).	Put in place on item (3).	
5. Eight screws (5), washers (2), and nuts (1).	Secure item (4) to item (3). 100 lb.-ft.	Torque between 90 and 100 lb.-ft.
<p><b>NOTE</b></p> <p><b>Follow-on maintenance action required:</b></p> <p><b>Install dust shield (para 3-162).</b></p> <p><b>Install camshaft and camshaft bracket assembly (para 3-160).</b></p>		
<p><b>3-942</b></p>		

**BRAKE SYSTEM.**

**3-161.SPIDER AND ANCHOR PIN REPLACEMENT (Continued).**

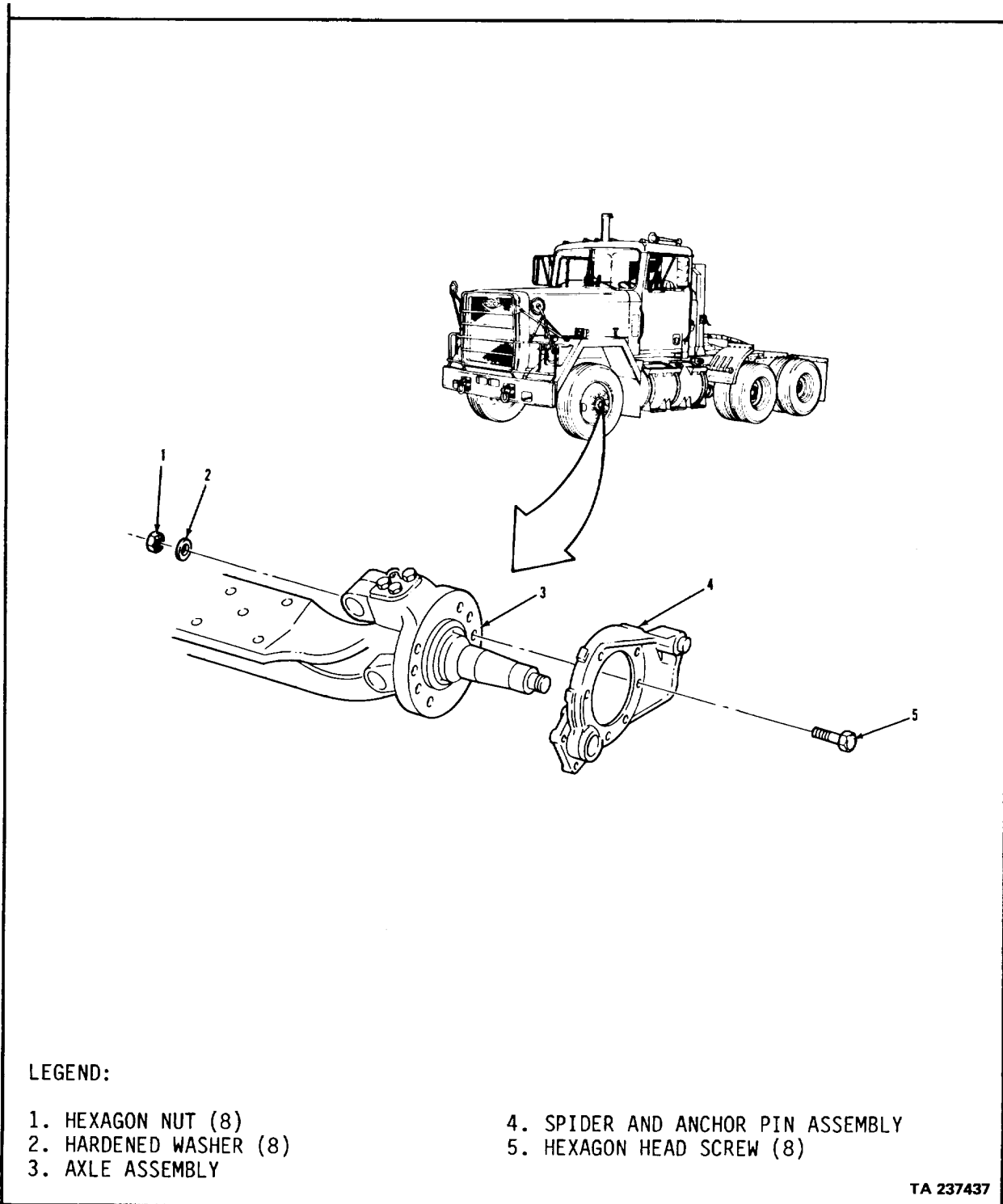

**BRAKE SYSTEM.**

**3-162. DUST SHIELD REPLACEMENT**

THIS TASK COVERS

- |                                  |                                      |
|----------------------------------|--------------------------------------|
| a. Removal from Front Axle       | d. Installation on Front Axle.       |
| b. Removal from Rear Tandem Axle | e. Installation on Rear Tandem Axle. |
| c. Cleaning and Inspection.      |                                      |

INITIAL SETUP

<u>APPLICABLE CONFIGURATIONS</u>	<u>EQUIPMENT CONDITION</u>	<u>CONDITION DESCRIPTION</u>
All	<u>PARAGRAPH</u> None	None.

TEST EQUIPMENT  
None.

SPECIAL TOOLS  
None.

MATERIALS/PARTS (P/N)  
None.

PERSONNEL REQUIRED  
One (MOS-63S)

SPECIAL ENVIRONMENTAL CONDITIONS  
None.

REFERENCES (TM)  
None

GENERAL SAFETY INSTRUCTIONS  
Engine off.  
Transmission in neutral.  
Park brake set.

TROUBLESHOOTING REFERENCES  
None.



**BRAKE SYSTEM.**

**3-162.DUST SHIELD REPLACEMENT (Continued).**

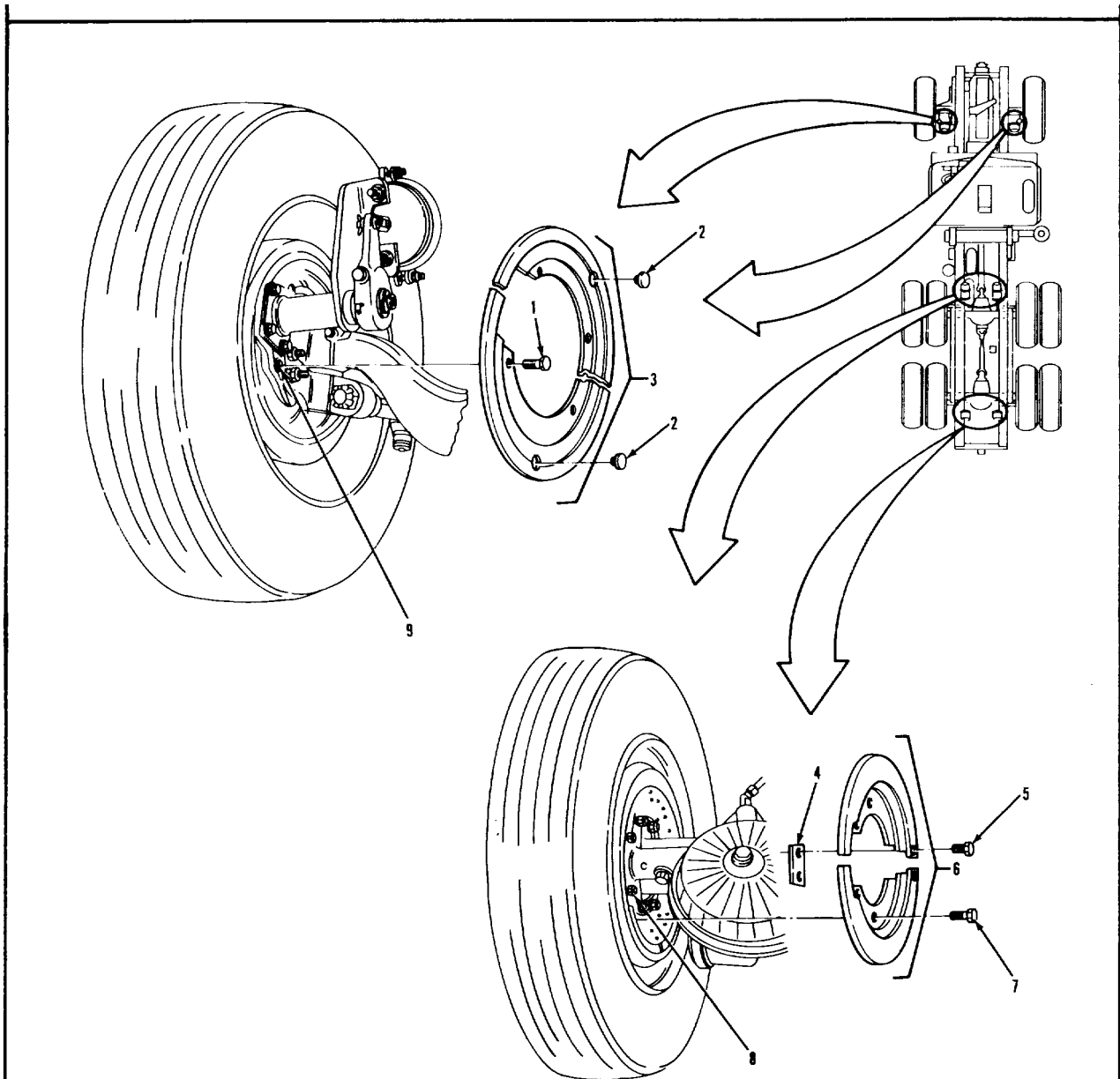

**LEGEND:**

- 1. SCREW (5)
- 2. HOLE PLUG (2)
- 3. DUST SHIELD
- 4. RETAINING CLIP
- 5. RETAINING CLIP SCREW (2)

- 6. DUST SHIELD
- 7. DUST SHIELD SCREW (4)
- 8. SPIDER AND ANCHOR PIN ASSEMBLY
- 9. SPIDER AND ANCHOR PIN ASSEMBLY

TA 237438

**BRAKE SYSTEM.**

**3-162. DUST SHIELD REPLACEMENT (Continued).**

LOCATION/ITEM	ACTION	REMARKS
<b><u>A. REMOVAL FROM FRONT AXLE.</u></b>		
1. Five screws (1).	Remove from item (3) and item (9).	
2. Two plugs (2).	Remove from item (3).	
<b><u>B. REMOVAL FROM REAR TANDEM AXLE.</u></b>		
3. Four screws (7).	Remove from item (6) and item (8).	
4. Two screws (5).	Remove from item (4) and item (6).	
<b><u>C. CLEANING AND INSPECTION.</u></b>		
5. All parts.	Clean and inspect.	Refer to paragraphs 3-4 and 3-5.
<b><u>D. INSTALLATION ON FRONT AXLE.</u></b>		
6. Two plugs (2).	Install in item (3).	
7. Shield (3).	Put in place on item (9).	
8. Five screws (1).	Secure item (3) to item (9).	
<b><u>E. INSTALLATION ON REAR TANDEM AXLE.</u></b>		
9. Shield (6).	Put in place on item (8).	
10. Two screws (5).	Secure item (4) to item (6).	
11. Four screws (7).	Secure item (6) to item (8).	
<b>NOTE</b>		
<b>Follow-on maintenance action required:</b>		
<b>None.</b>		

**BRAKE SYSTEM.**

**3-162. DUST SHIELD REPLACEMENT (Continued).**

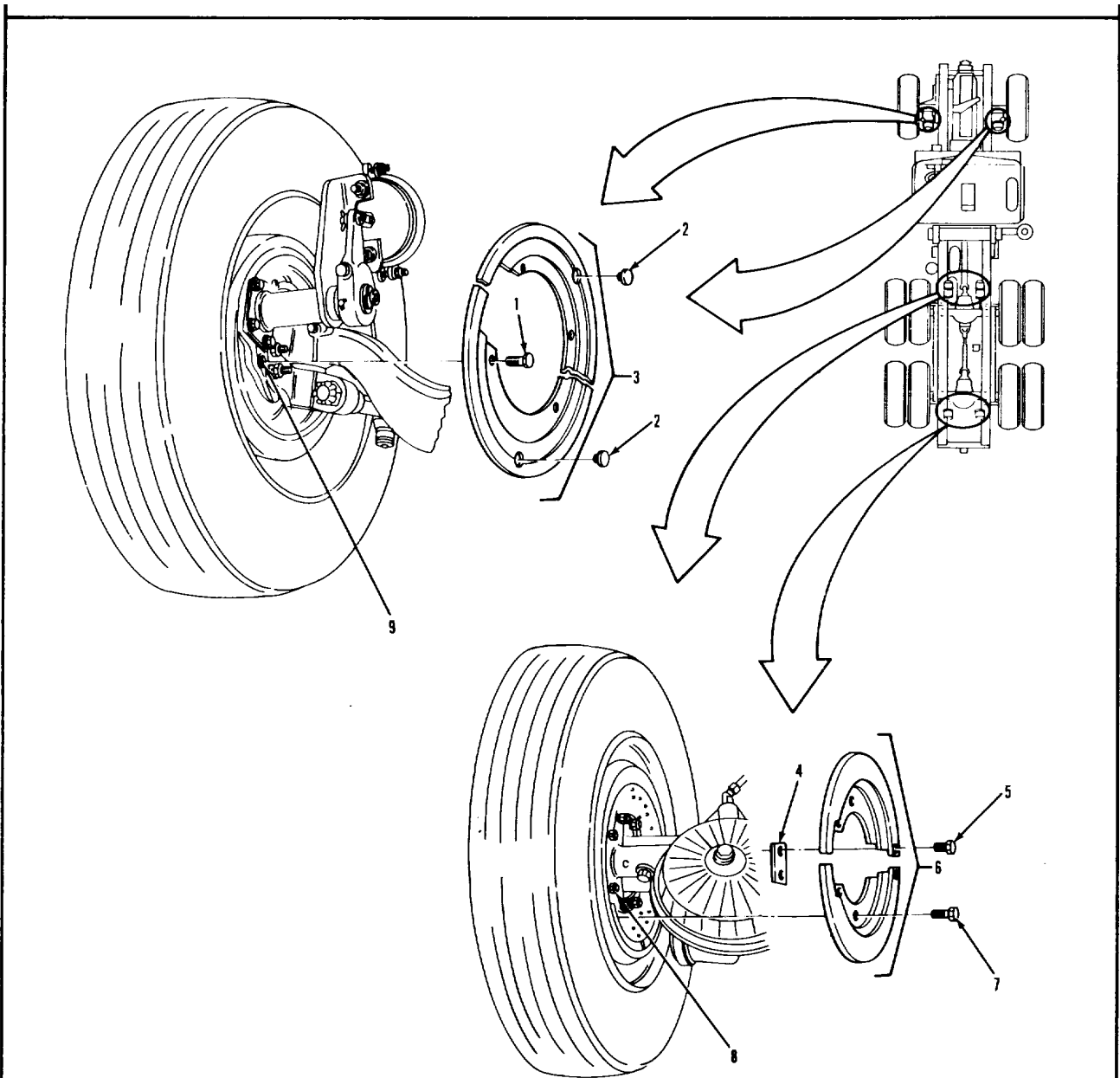

**LEGEND:**

- |                             |                                   |
|-----------------------------|-----------------------------------|
| 1. SCREW (5)                | 6. DUST SHIELD                    |
| 2. HOLE PLUG (2)            | 7. DUST SHIELD SCREW (4)          |
| 3. DUST SHIELD              | 8. SPIDER AND ANCHOR PIN ASSEMBLY |
| 4. RETAINING CLIP           | 9. SPIDER AND ANCHOR PIN ASSEMBLY |
| 5. RETAINING CLIP SCREW (2) |                                   |

TA 237439

**BRAKE SYSTEM.**

**3-163. AIR LINES AND FITTINGS REPLACEMENT.**

THIS TASK COVERS

Replacement.

INITIAL SETUP

<p><u>APPLICABLE CONFIGURATIONS</u> All</p>	<p><u>EQUIPMENT CONDITION PARAGRAPH</u> TM 9-2320-283-10</p>	<p><u>CONDITION DESCRIPTION</u> Air system draincocks opened.</p>
<p><u>TEST EQUIPMENT</u> None.</p>		
<p><u>SPECIAL TOOLS</u> None.</p>		
<p><u>MATERIALS/PARTS (P/N)</u> Tie, cable (as required) (96906) MS 3367-7-9.</p>		
<p><u>PERSONNEL REQUIRED</u> One (MOS-63S)</p>	<p><u>SPECIAL ENVIRONMENTAL CONDITIONS</u> None.</p>	
<p><u>REFERENCES (TM)</u> TM 9-2320-283-200P</p>	<p><u>GENERAL SAFETY INSTRUCTIONS</u> Engine off. Transmission in neutral. Park brake set.</p>	
<p><u>TROUBLESHOOTING REFERENCES</u> Paragraph 2-11.</p>		

**BRAKE SYSTEM.****3-163. AIR LINES AND FITTINGS REPLACEMENT (Continued).****REPLACEMENT.****WARNING**

Never work on air system components without first draining air pressure. Failure to follow this precaution can result in serious personal injury.

**NOTE**

- For replacement of vehicle air lines and fittings, refer to Appendix D for routing and location information and to Appendix E for exact specifications for making new air lines.
- Use standard shop maintenance practices when removing air line clamps and cable ties.
- Be sure to tag connector ends to ensure proper installation and operation.
- Follow-on maintenance action required:  
Close air system draincocks and start engine (TM 9-2320-283-10).  
Check air system for leaks (para 3-8).

**BRAKE SYSTEM.**

**3-164. FRONT AXLE AND REAR-REAR AXLE BRAKE CHAMBER REPLACEMENT.**

THIS TASK COVERS

- a. Removal.
- b. Cleaning and Inspection.
- c. Installation.
- d. Operational Checkout.

INITIAL SETUP

<u>APPLICABLE CONFIGURATIONS</u>	<u>EQUIPMENT CONDITION PARAGRAPH</u>	<u>CONDITION DESCRIPTION</u>
All	TM 9-2320-283-10	Air system draincocks open.

TEST EQUIPMENT  
None.

SPECIAL TOOLS  
None.

MATERIALS/PARTS (P/N)  
Tape, thread sealing  
Item 32, Appendix C.  
Pin, cotter  
(24617) 103395.

PERSONNEL REQUIRED  
Two (MOS-63S)

SPECIAL ENVIRONMENTAL CONDITIONS  
None.

REFERENCES (TM)  
TM 9-2320-283-10  
TM 9-2320-283-20P

GENERAL SAFETY INSTRUCTIONS  
Engine off.  
Transmission in neutral.  
Wheels blocked.

TROUBLESHOOTING REFERENCES  
Paragraph 2-11.

**BRAKE SYSTEM.**

**3-164. FRONT AXLE AND REAR-REAR AXLE BRAKE CHAMBER REPLACEMENT (Continued).**

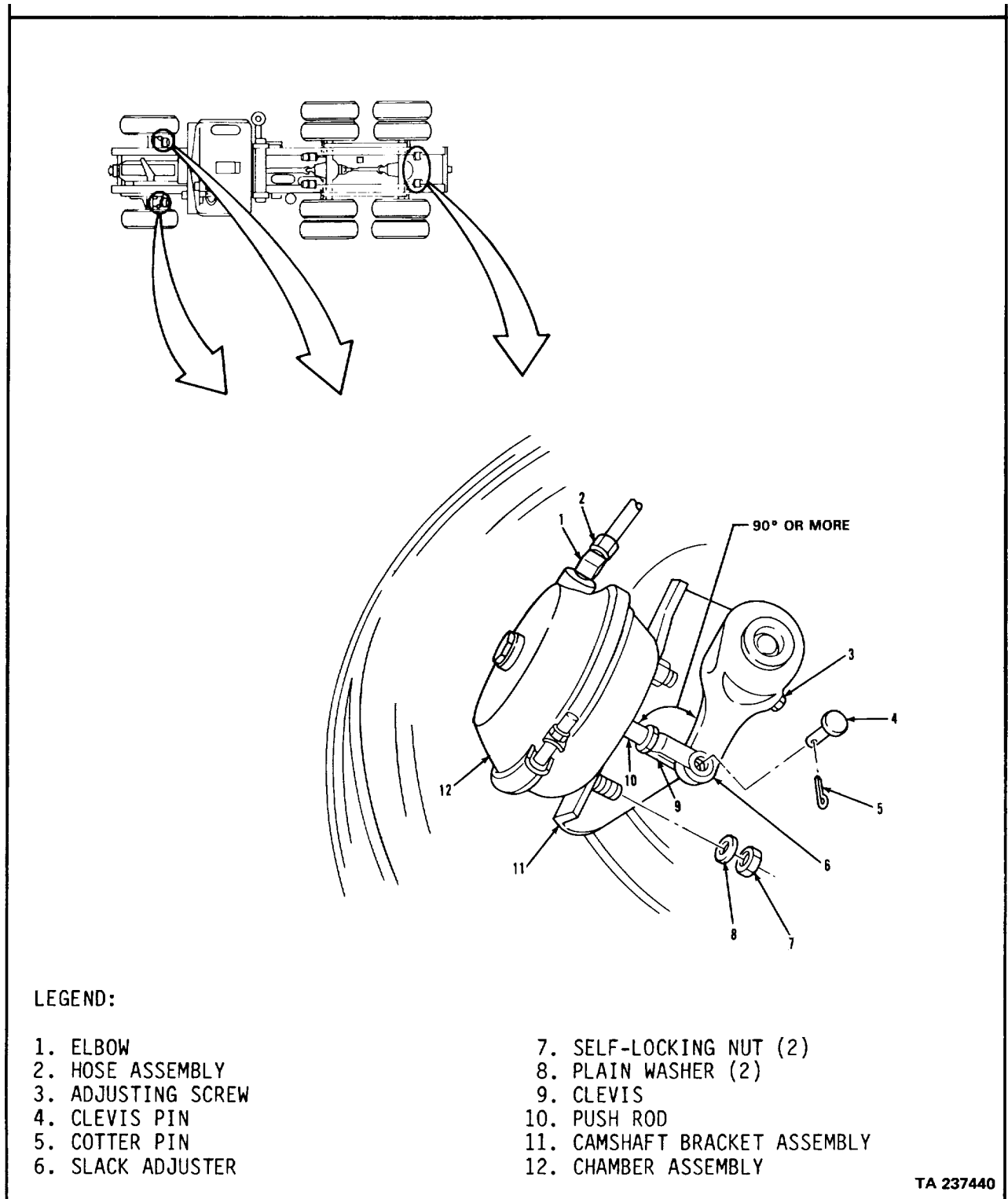

TA 237440

**BRAKE SYSTEM.**

3-164. FRONT AXLE AND REAR-REAR AXLE BRAKE CHAMBER REPLACEMENT(Continued).		
LOCATION/ITEM	ACTION	REMARKS
<b><u>WARNING</u></b>		
Never work on air system components without first draining air pressure. Failure to follow this precaution can result in serious personal injury.		
<b><u>NOTE</u></b>		
Replacement of the four front axle and rear-rear axle brake chambers is the same.		
<b><u>A. REMOVAL.</u></b>		
1. Hose assembly (2).	Remove from item (1).	
2. Pin (5).	Remove from item (4).	Discard item (5).
3. Pin (4)	Remove from item (6) and item (9).	
4. Two nuts (7) and washers (8).	Remove from item (12).	
5. Chamber assembly (12).	Remove from item (11).	
6. Elbow (1).	Remove from item (12).	
<b><u>B. CLEANING AND INSPECTION.</u></b>		
7. All parts.	Wipe clean with solvent soaked rag.	
8. All parts.	Inspect.	a. Refer to paragraph 3-4. b. If item (12) is unserviceable, repair (para 3-165).



**BRAKE SYSTEM.**

**3-164. FRONT AXLE AND REAR-REAR AXLE BRAKE CHAMBER REPLACEMENT (Continued).**

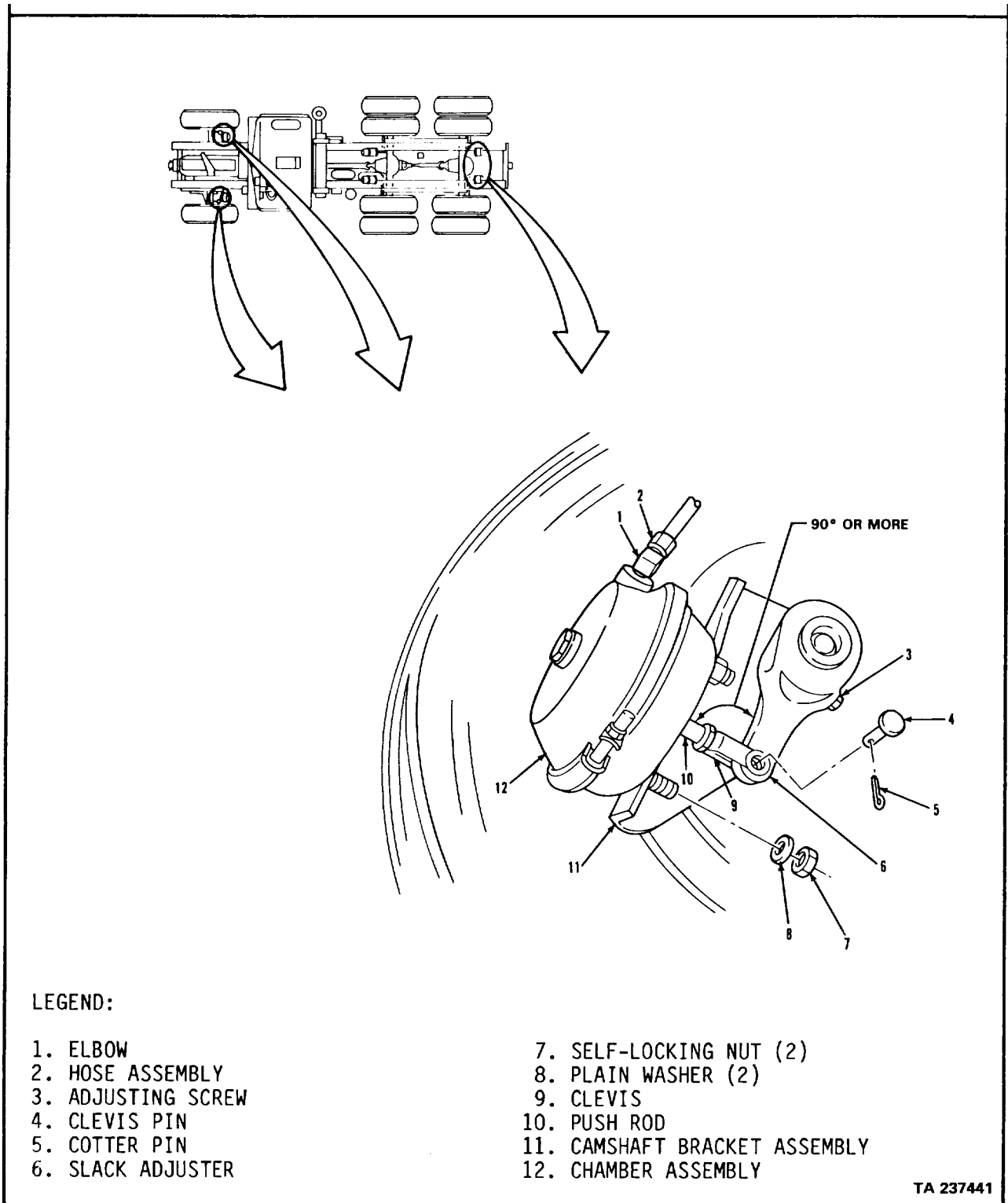

**BRAKE SYSTEM.****3-164. FRONT AXLE AND REAR-REAR AXLE BRAKE CHAMBER REPLACEMENT(Continued).**

LOCATION/ITEM	ACTION	REMARKS
<b><u>C. INSTALLATION.</u></b>		
9. Elbow (1).	Install in item (12).	Put thread sealing tape on pipe threads.
10. Chamber assembly (12).	Put in place on item (11).	
11. Two nuts (7) and washers (8).	Secure item (12) to item (11).	
12. Adjusting screw (3).	Press and turn until item (4) can be installed in item (9) and item (6).	
13. Pin (4).	Install in item (9) and item (6).	
14. New pin (5).	Install in item (4).	
15. Hose assembly (2).	Install on item (1).	
16. Slack adjuster (6).	Adjust.	Refer to paragraph 3-157.
<b><u>D. OPERATIONAL CHECK.</u></b>		
17. Air system draincocks.	Close.	Refer to TM 9-2320-283-10.
18. Engine.	Start.	Refer to TM 9-2320-283-10.
19. Service brakes.	Apply and hold.	Refer to TM 9-2320-283-10.
20. Air system.	Check for leaks.	Refer to paragraph 3-8.
21. Push rod (10) and slack adjuster (6).	Check angle with brakes applied as shown.	An angle of 90° or more is required. If angle is less than 90° adjust clevis (9) and recheck angle.
22. Engine.	Shut down.	Refer to TM 9-2320-283-10.
<b>NOTE</b>		
<b>Follow-on maintenance action required:</b>		
<b>None.</b>		

**BRAKE SYSTEM.**

**3-164. FRONT AXLE AND REAR-REAR AXLE BRAKE CHAMBER REPLACEMENT (Continued).**

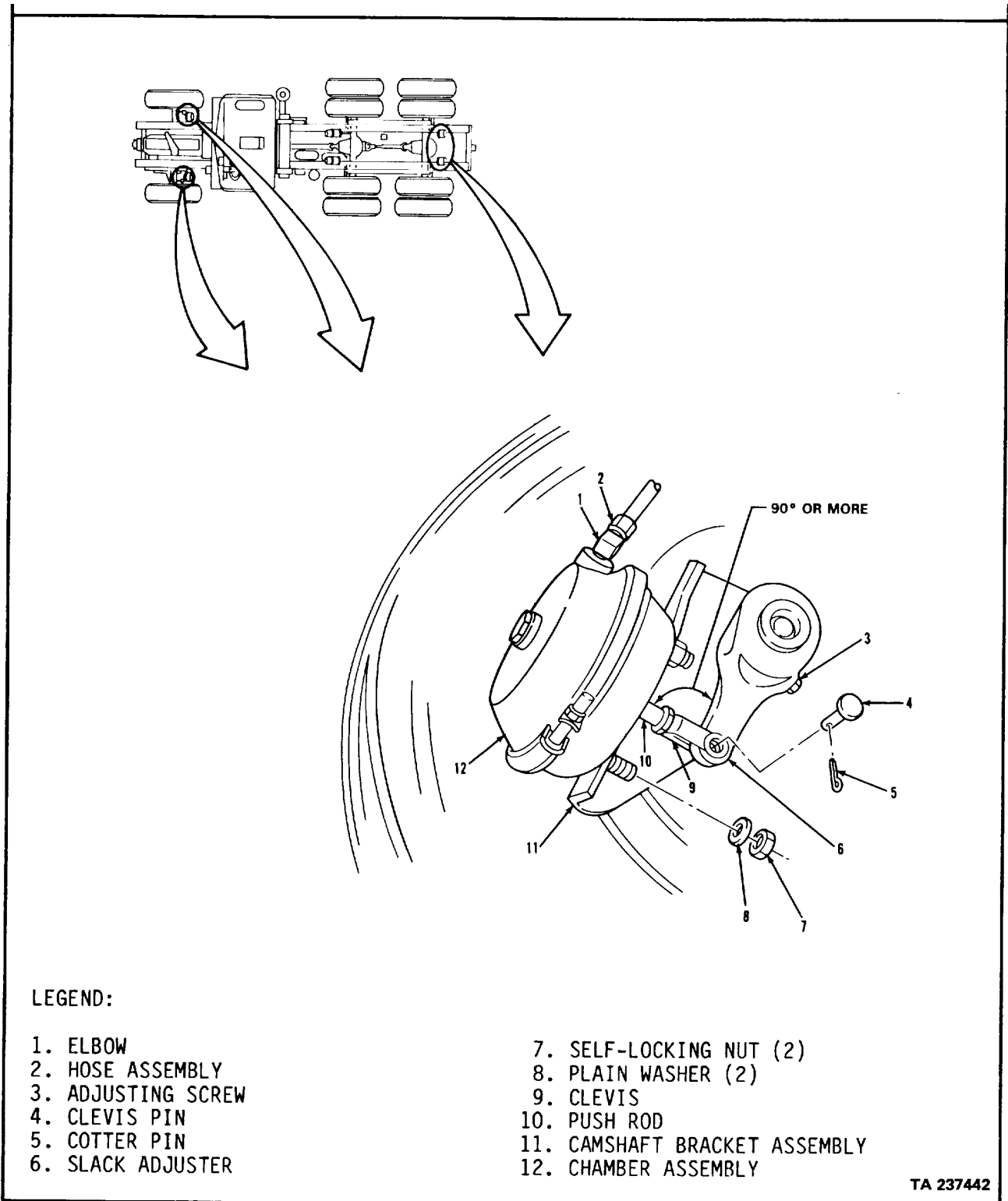

**BRAKE SYSTEM.**

**3-165. FRONT AXLE AND REAR-REAR AXLE BRAKE CHAMBER REPAIR.**

THIS TASK COVERS

- a. Disassembly.
- b. Cleaning and Inspection.
- c. Assembly.

INITIAL SETUP

<u>APPLICABLE CONFIGURATIONS</u> All	<u>EQUIPMENT CONDITION PARAGRAPH</u> 3-164	<u>CONDITION DESCRIPTION</u> Brake chamber removed.
---	---	--

TEST EQUIPMENT  
None.

SPECIAL TOOLS  
None.

MATERIALS/PARTS (P/N)  
Diaphragm  
(50153) 1133M009 (Front axle);  
(50153) 1126M009 (Rear axle).

PERSONNEL REQUIRED  
One (MOS-63S)

SPECIAL ENVIRONMENTAL CONDITIONS  
Work area clean and away from blowing  
dirt and dust.

REFERENCES (TM)  
TM 9-2320-283-20P

GENERAL SAFETY INSTRUCTIONS  
None.

TROUBLESHOOTING REFERENCES  
Paragraph 2-11.

**BRAKE SYSTEM.**

**3-165. FRONT AXLE AND REAR-REAR AXLE BRAKE CHAMBER REPAIR (Continued).**

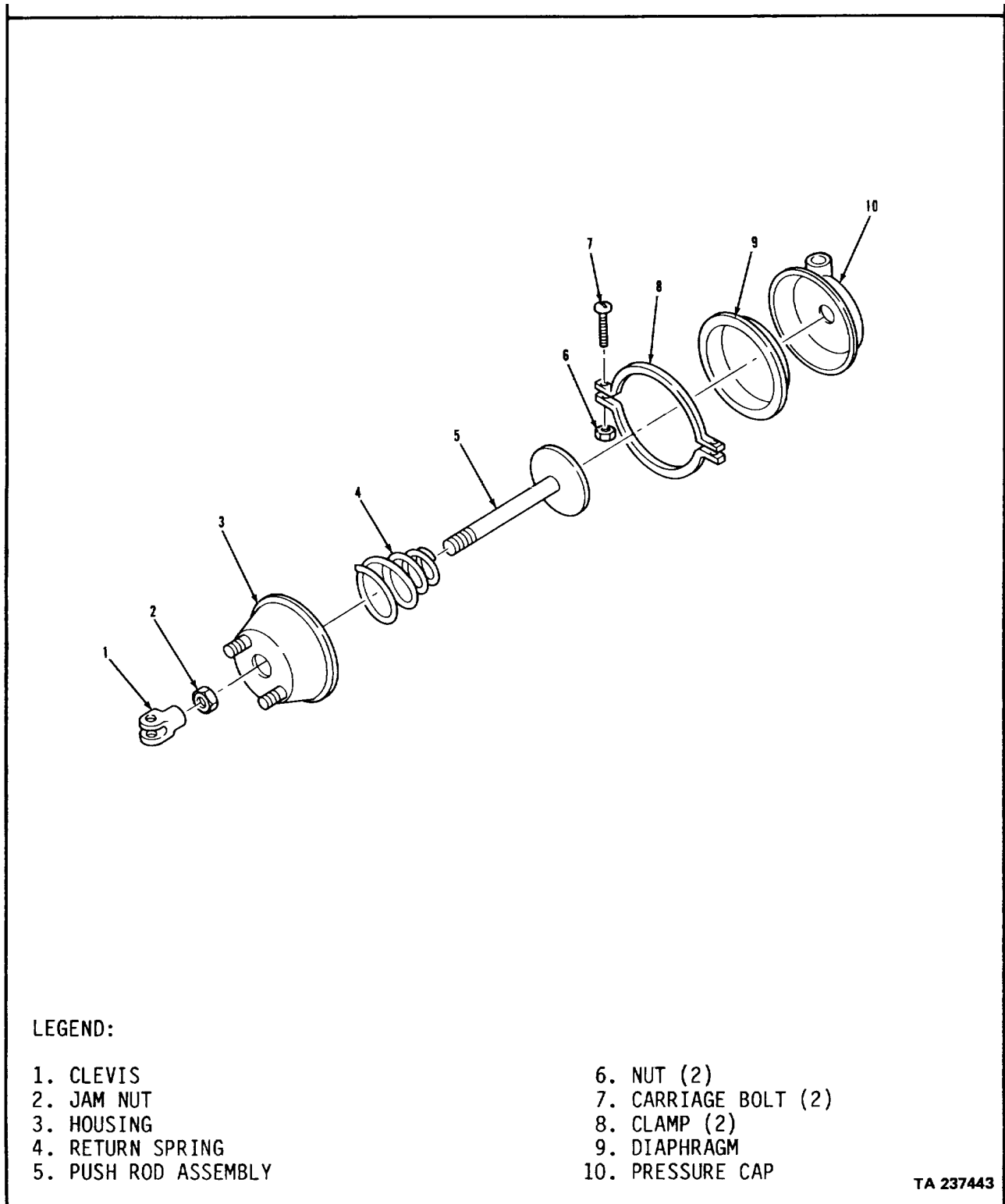

**BRAKE SYSTEM.**

3-165. FRONT AXLE AND REAR-REAR AXLE BRAKE CHAMBER REPAIR(Continued).		
LOCATION/ITEM	ACTION	REMARKS
<b>NOTE</b>		
<b>Repair of front axle and rear-rear axle brake chambers is the same.</b>		
<b><u>A. DISASSEMBLY.</u></b>		
1. Nut (2).	Loosen from item (1).	
2. Clevis (1).	Remove from item (5).	
3. Nut (2).	Finger tighten against item (3).	
4. Cap (10) and housing (3).	Scribe a mark on both.	Used to aid in assembly.
5. Two nuts (6), bolts (7), and clamps (8).	Remove from item (3) and item (10).	
6. Cap (10) and diaphragm (9).	Remove from item (3).	Discard item (9).
7. Nut (2).	Remove from item (5).	
8. Push rod assembly (5) and spring (4).	Remove from item (3).	
<b><u>B. CLEANING AND INSPECTION.</u></b>		
9. All parts.	Clean and inspect.	Refer to paragraphs 3-4 and 3-5.
<b><u>C. ASSEMBLY.</u></b>		
10. Spring (4) and push rod assembly (5).	Put in item (3).	

**BRAKE SYSTEM.**

**3-165. FRONT AXLE AND REAR-REAR AXLE BRAKE CHAMBER REPAIR (Continued).**

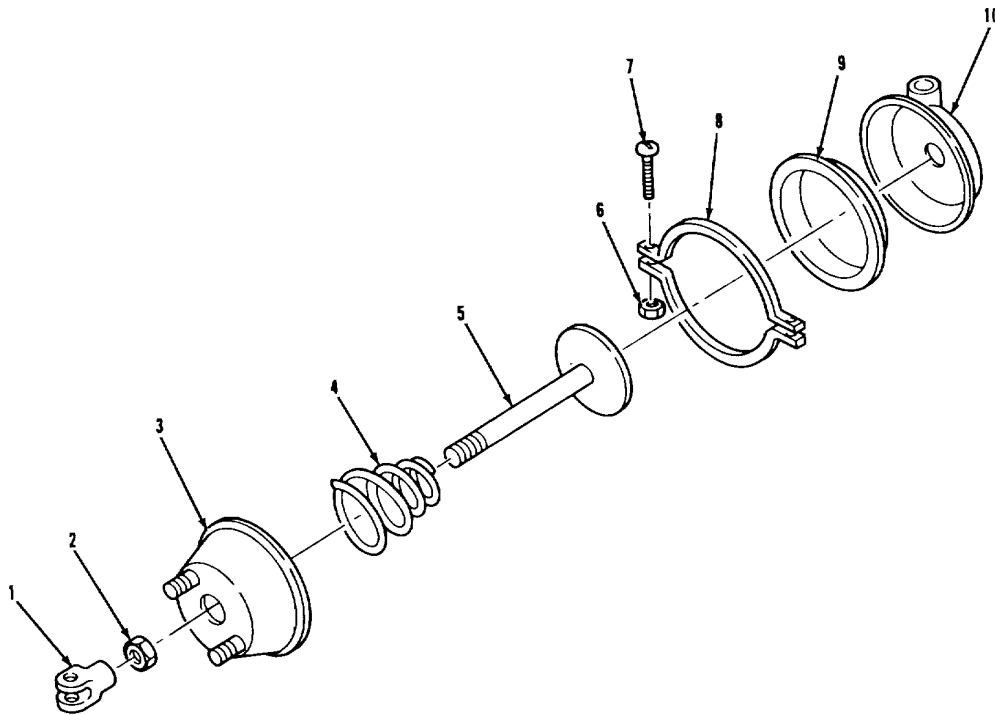

**LEGEND:**

- 1. CLEVIS
- 2. JAM NUT
- 3. HOUSING
- 4. RETURN SPRING
- 5. PUSH ROD ASSEMBLY

- 6. NUT (2)
- 7. CARRIAGE BOLT (2)
- 8. CLAMP (2)
- 9. DIAPHRAGM
- 10. PRESSURE CAP

TA 237444

**BRAKE SYSTEM.**

<b>3-165. FRONT AXLE AND REAR-REAR AXLE BRAKE CHAMBER REPAIR(Continued).</b>		
<b>LOCATION/ITEM</b>	<b>ACTION</b>	<b>REMARKS</b>
<b><u>C. ASSEMBLY (Continued).</u></b>		
11. Nut (2).	Screw on item (5) as far as it will go.	
12. Cap (10) and new diaphragm (9).	Install on item (3).	Use alinement marks made in step 4.
13. Two bolts (7), nuts (6), and clamps (8).	Secure item (10) to item (3).	
14. Clevis (1).	Install on item (5).	
15. Nut (2).	Tighten against item (1).	
<b>NOTE</b>		
<b>Follow-on maintenance action required:</b>		
<b>Install front axle or rear-rear axle brake chamber (para 3-164).</b>		



**BRAKE SYSTEM.**

**3-165. FRONT AXLE AND REAR-REAR AXLE BRAKECHAMBER REPAIR (Continued).**

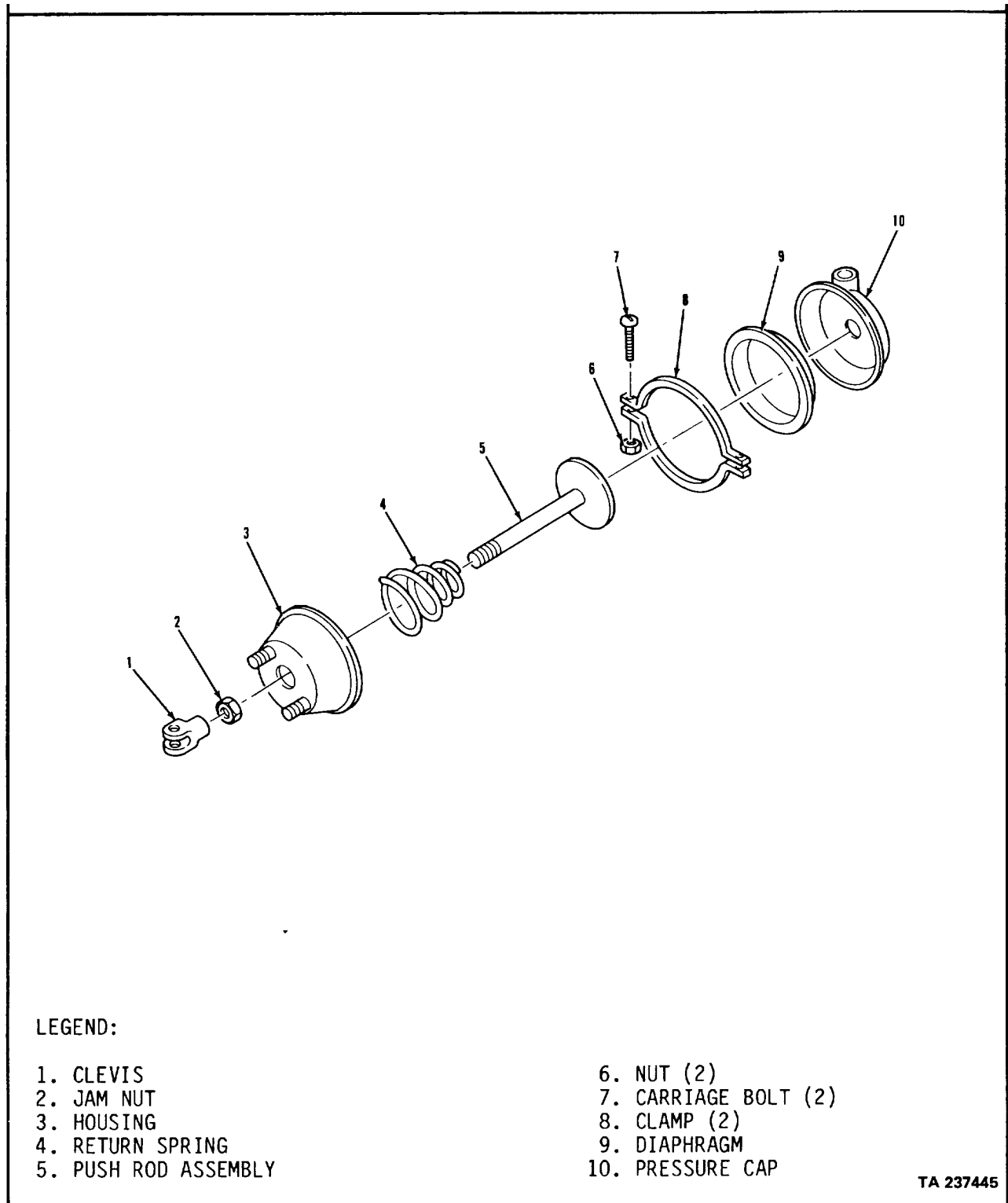

**BRAKE SYSTEM.**

**3-166. FORWARD-REAR AXLE BRAKE CHAMBER REPLACEMENT.**

THIS TASK COVERS

- a. Disassembly.
- b. Cleaning and Inspection.
- c. Installation.

INITIAL SETUP

<p><u>APPLICABLE CONFIGURATIONS</u> All</p>	<p><u>EQUIPMENT CONDITION PARAGRAPH</u> TM 9-2320-283-10</p>	<p><u>CONDITION DESCRIPTION</u> Spring brake power spring manually compressed.</p>
<p><u>TEST EQUIPMENT</u> None</p>	<p>TM 9-2320-283-10</p>	<p>Air system draincocks open.</p>
<p><u>SPECIAL TOOLS</u> None.</p>		
<p><u>MATERIALS/PARTS (P/N)</u> Rag, wiping Item 22, Appendix C. Solvent, drycleaning, SD-2 Item 29, Appendix C. Tape, thread sealing Item 32, Appendix C. Pin, cotter (24617) 103395.</p>		
<p><u>PERSONNEL REQUIRED</u> One (MOS-63S)</p>	<p><u>SPECIAL ENVIRONMENTAL CONDITIONS</u> None.</p>	
<p><u>REFERENCES (TM)</u> TM 9-2320-283-10 TM 9-2320-283-20P</p>	<p><u>GENERAL SAFETY INSTRUCTIONS</u> Engine off. Transmission in neutral. Wheels blocked.</p>	
<p><u>TROUBLESHOOTING REFERENCES</u> Paragraph 2-11.</p>		

**BRAKE SYSTEM.**

**3-166. FORWARD-REAR AXLE BRAKE CHAMBER REPLACEMENT (Continued).**

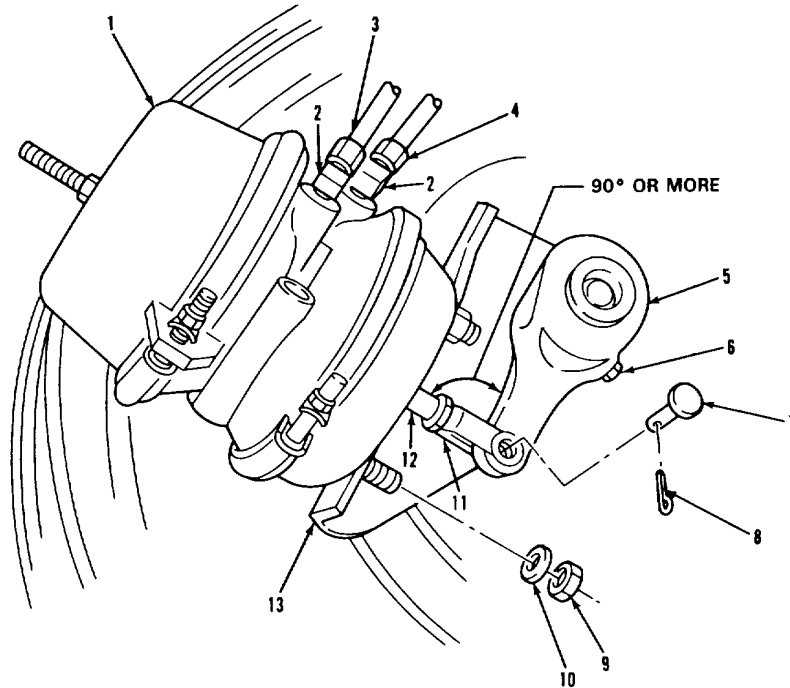

**LEGEND:**

- |  |                               |
|--|-------------------------------|
| 1. BRAKE CHAMBER ASSEMBLY                    | 8. COTTER PIN                 |
| 2. ELBOW (2)                                 | 9. NUT (2)                    |
| 3. NONMETALLIC TUBE (TO TEE)                 | 10. PLAIN WASHER (2)          |
| 4. NONMETALLIC TUBE (TO QUICK RELEASE VALVE) | 11. CLEVIS                    |
| 5. AUTOMATIC SLACK ADJUSTER                  | 12. PUSH ROD ASSEMBLY         |
| 6. ADJUSTING SCREW                           | 13. CAMSHAFT BRACKET ASSEMBLY |
| 7. CLEVIS PIN                                |                               |

TA 237446

**BRAKE SYSTEM.**

3-166. FORWARD-REAR AXLE BRAKE CHAMBER REPLACEMENT (Continued).		
LOCATION/ITEM	ACTION	REMARKS
<b><u>WARNING</u></b>		
<ul style="list-style-type: none"> <li>• Forward rear axle brake chamber contains a powerful spring. Do not try to open chamber.</li> <li>• Never work on air system components without first draining air pressure. Failure to follow this precaution can result in serious personal injury.</li> </ul>		
<b><u>A. REMOVAL.</u></b>		
1. Tube (3) and tube (4).	Remove from two items (2).	Tag for identification.
2. Pin (8).	Remove from item (7).	Discard item (8).
3. Pin (7).	Remove from item (11) and item (5).	
4. Two nuts (9) and washers (10).	Remove from item (1).	
5. Chamber assembly (1).	Remove from item (13).	
6. Two elbows (2).	Remove from item (1).	
<b><u>B. CLEANING AND INSPECTION.</u></b>		
7. Chamber assembly (1) soaked rag.	Wipe clean with solvent.	
8. All parts.	Inspect.	<ul style="list-style-type: none"> <li>a. Refer to paragraph 3-5.</li> <li>b. If item (1) is unserviceable, refer to DS/GS maintenance for repair.</li> </ul>

**BRAKE SYSTEM.**

**3-166. FORWARD-REAR AXLE BRAKE CHAMBER REPLACEMENT (Continued).**

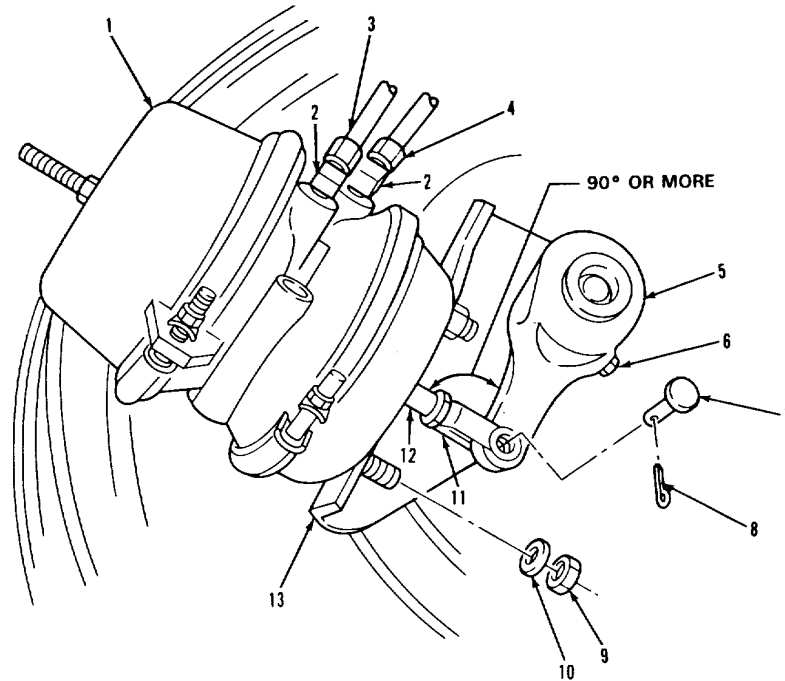

**LEGEND:**

- |  |                               |
|--|-------------------------------|
| 1. BRAKE CHAMBER ASSEMBLY                    | 8. COTTER PIN                 |
| 2. ELBOW (2)                                 | 9. NUT (2)                    |
| 3. NONMETALLIC TUBE (TO TEE)                 | 10. PLAIN WASHER (2)          |
| 4. NONMETALLIC TUBE (TO QUICK RELEASE VALVE) | 11. CLEVIS                    |
| 5. AUTOMATIC SLACK ADJUSTER                  | 12. PUSH ROD ASSEMBLY         |
| 6. ADJUSTING SCREW                           | 13. CAMSHAFT BRACKET ASSEMBLY |
| 7. CLEVIS PIN                                |                               |

TA 237447

**BRAKE SYSTEM.****3-166. FORWARD-REAR AXLE BRAKE CHAMBER REPLACEMENT (Continued).**

LOCATION/ITEM	ACTION	REMARKS
<b><u>C. INSTALLATION.</u></b>		
<b>NOTE</b>		
<b>Before installing chamber assembly, manually compress spring brake power spring (TM 9-2320-283-10).</b>		
9. Chamber assembly (1).	Put in place on item (13).	
10. Two nuts (9) and washers (10).	Secure item (1) to item (13).	Torque between 90 and 100 lb-ft.
11. Adjusting screw (6).	Push in and turn until item (7) can be installed in item (11) and item (5).	
12. Pin (7).	Install in item (11) and item (5).	
13. New pin (8).	Install in item (7).	
14. Two elbows (2).	Install in item (1).	Put thread sealing tape on pipe threads.
15. Tubes (3) and (4).	Install on two items (2).	
16. Slack adjuster (5).	Adjust.	Refer to paragraph 3-157.
17. Chamber assembly (1).	Manually release spring brake power spring.	Refer to TM 9-2320-283-10.
18. Push rod (12) and slack adjuster (5).	Check angle.	An angle of 90° or more is required. If angle is less than 90°, adjust clevis (11) and recheck angle.
<b>NOTE</b>		
<b>Follow-on maintenance action required:</b>		
<b>Close air system draincocks and start engine (TM 9-2320-283-10). Check air system for leaks (para 3-8).</b>		

**BRAKE SYSTEM.**

**3-166. FORWARD-REAR AXLE BRAKE CHAMBER REPLACEMENT (Continued).**

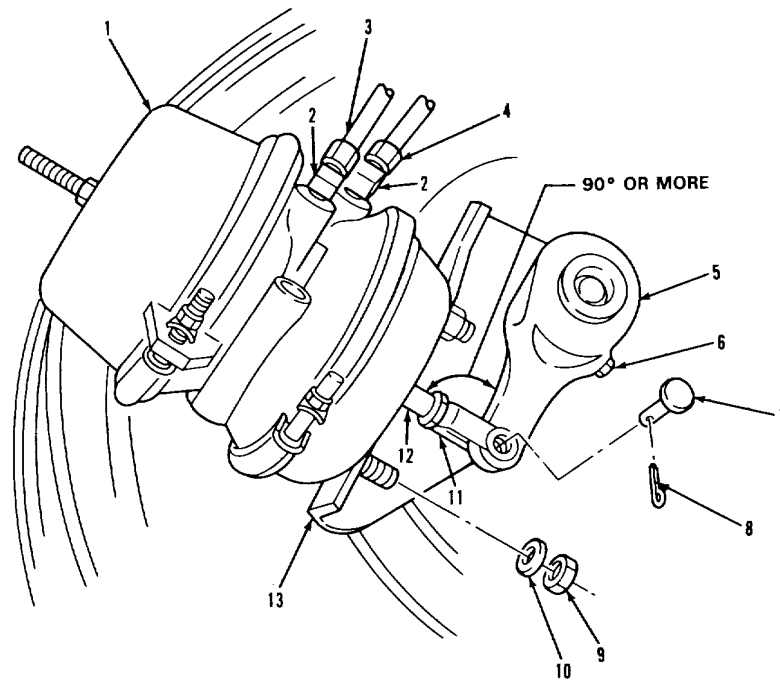

**LEGEND:**

- |  |                               |
|--|-------------------------------|
| 1. BRAKE CHAMBER ASSEMBLY                    | 8. COTTER PIN                 |
| 2. ELBOW (2)                                 | 9. NUT (2)                    |
| 3. NONMETALLIC TUBE (TO TEE)                 | 10. PLAIN WASHER (2)          |
| 4. NONMETALLIC TUBE (TO QUICK RELEASE VALVE) | 11. CLEVIS                    |
| 5. AUTOMATIC SLACK ADJUSTER                  | 12. PUSH ROD ASSEMBLY         |
| 6. ADJUSTING SCREW                           | 13. CAMSHAFT BRACKET ASSEMBLY |
| 7. CLEVIS PIN                                |                               |

TA 237448

**BRAKE SYSTEM.**

**3-167. FRONT EXTERNAL AIR COUPLINGS REPLACEMENT.**

THIS TASK COVERS

- a. Right-Hand Couplings Removal.
- b. Left-Hand Couplings Removal.
- c. Left-Hand Couplings Installation.
- d. Right-Hand Couplings Installation.

INITIAL SETUP

<u>APPLICABLE CONFIGURATIONS</u> All	<u>EQUIPMENT CONDITION PARAGRAPH</u> TM 9-2320-283-10.	<u>CONDITION DESCRIPTION</u> Air system draincocks open.
---	---	---

TEST EQUIPMENT  
None.

SPECIAL TOOLS  
None.

MATERIALS/PARTS (P/N)  
Tape, thread sealing  
Item 32, Appendix C.

PERSONNEL REQUIRED  
One (MOS-63S).

SPECIAL ENVIRONMENTAL CONDITIONS  
None.

REFERENCES (TM)  
TM 9-2320-283-10.

GENERAL SAFETY INSTRUCTIONS  
Engine off.  
Transmission in neutral.  
Park brake set.

TROUBLESHOOTING REFERENCES  
Paragraph 2-11.



**BRAKE SYSTEM.**

**3-167. FRONT EXTERNAL AIR COUPLINGS REPLACEMENT (Continued).**

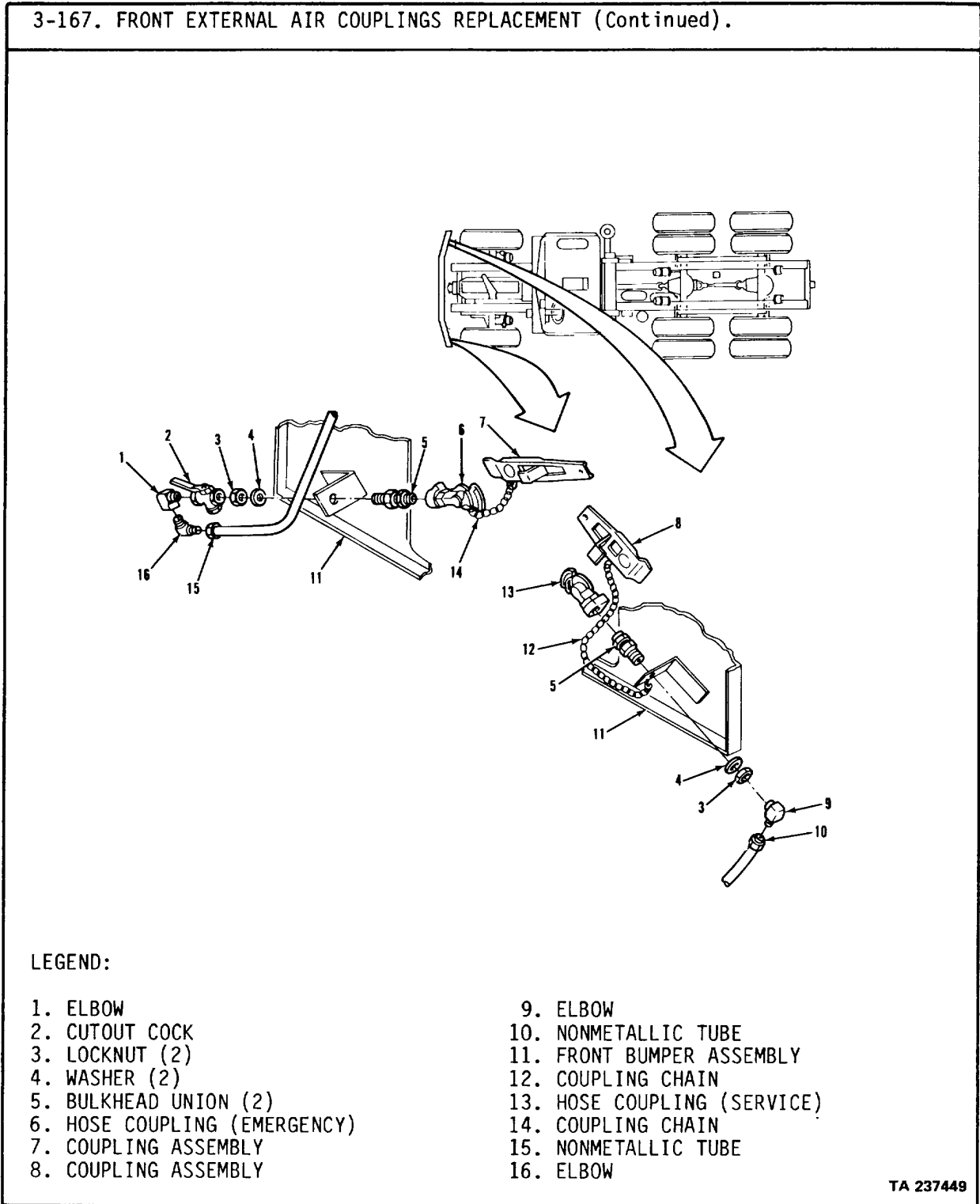

TA 237449

**BRAKE SYSTEM.****3-167. FRONT EXTERNAL AIR COUPLINGS REPLACEMENT (Continued).**

LOCATION/ITEM	ACTION	REMARKS
<p><b><u>WARNING</u></b></p> <p><b>Never work on air system components without first draining air pressure. Failure to follow this precaution can result in serious personal injury.</b></p> <p><b><u>CAUTION</u></b></p> <p><b>Right-hand coupling is vented. Using right-hand coupling on the left side or rear will cause brakes to lock.</b></p>		
<b><u>A. RIGHT-HAND COUPLINGS REMOVAL.</u></b>		
1. Coupling assembly (8).	Remove from item (13).	
2. Chain (12).	Unhook from item (11).	Use pliers.
3. Tube (10).	Remove from item (9).	
4. Elbow (9).	Remove from item (5).	
5. Locknut (3) and washer (4).	Remove from item (5).	
6. Union (5) and coupling (13).	Remove from item (11).	
7. Union (5).	Remove from item (13).	
<b><u>B. LEFT-HAND COUPLINGS REMOVAL.</u></b>		
8. Coupling assembly (7).	Remove from item (6).	
9. Chain (14).	Unhook from item (6).	Use pliers.
10. Tube (15).	Remove from item (16).	
11. Locknut (3).	Loosen.	
12. Elbow (16).	Remove from item (1).	
13. Elbow (1).	Remove from item (2).	

**BRAKE SYSTEM.**

**3-167. FRONT EXTERNAL AIR COUPLINGS REPLACEMENT (Continued).**

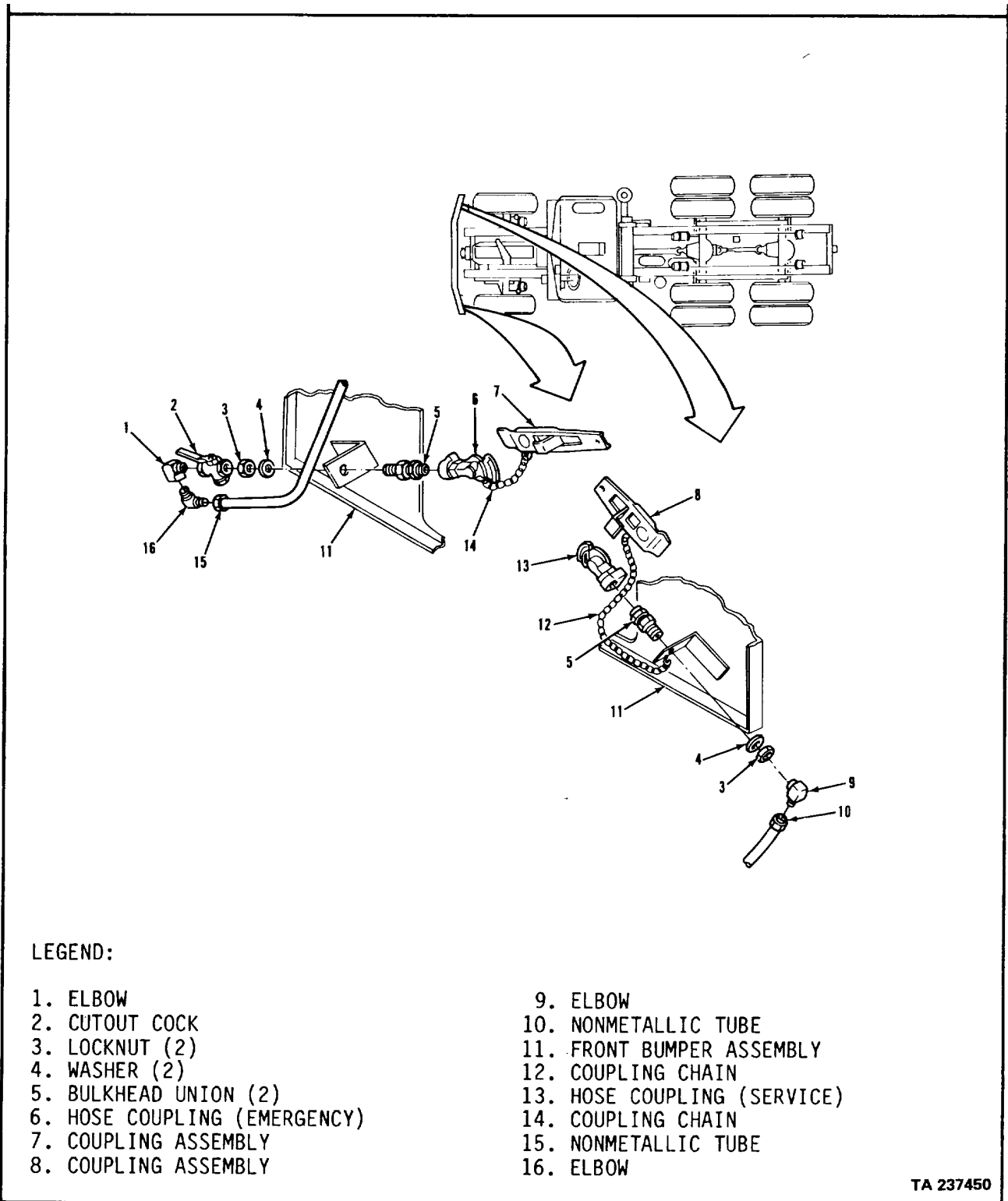

TA 237450

**BRAKE SYSTEM.****3-167. FRONT EXTERNAL AIR COUPLINGS REPLACEMENT (Continued).**

LOCATION/ITEM	ACTION	REMARKS
<b><u>B. LEFT-HAND COUPLINGS REMOVAL (Continued).</u></b>		
14. Cock (2).	Remove from item (5).	
15. Locknut (3) and washer (4).	Remove from item (5).	
16. Union (5) and coupling (6).	Remove from item (11).	
17. Union (5).	Remove from item (6).	
<b><u>C. LEFT-HAND COUPLINGS INSTALLATION.</u></b>		
18. Union (5).	Install in item (6).	Put thread sealing tape on threads.
19. Union (5) and coupling (6).	Put in place in item (11).	
20. Locknut (3) and washer (4).	Put on place in item (5) finger tight.	
21. Cock (2).	Install on item (5).	Put thread sealing tape on threads.
22. Elbow (1).	Install in item (2).	
23. Elbow (16).	Install in item (1).	Put thread sealing tape on threads.
24. Tube (15).	Install on item (16).	
25. Locknut (3).	Tighten against item (11).	
26. Coupling assembly (7).	Install on item (6).	
27. Chain (14).	Hook to item (6).	Use pliers.

**BRAKE SYSTEM.**

**3-167. FRONT EXTERNAL AIR COUPLINGS REPLACEMENT (Continued).**

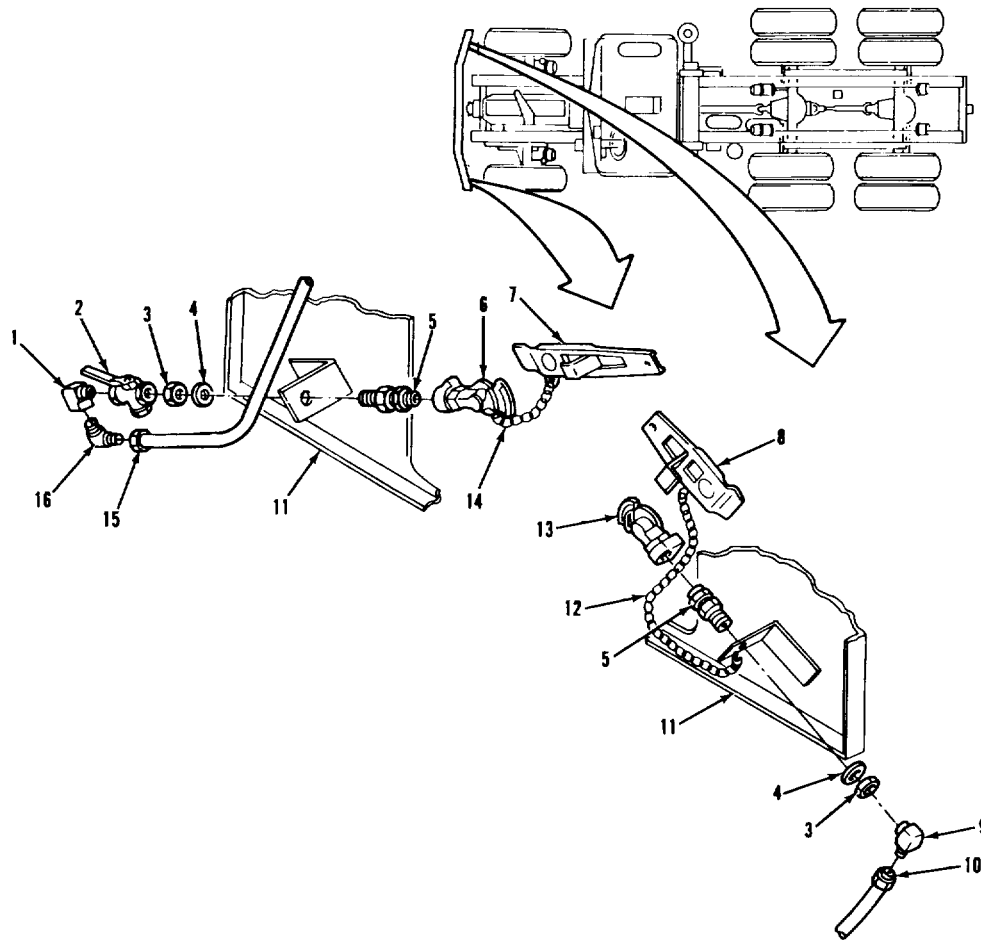

**LEGEND:**

- |                              |                             |
|------------------------------|-----------------------------|
| 1. ELBOW                     | 9. ELBOW                    |
| 2. CUTOUT COCK               | 10. NONMETALLIC TUBE        |
| 3. LOCKNUT (2)               | 11. FRONT BUMPER ASSEMBLY   |
| 4. WASHER (2)                | 12. COUPLING CHAIN          |
| 5. BULKHEAD UNION (2)        | 13. HOSE COUPLING (SERVICE) |
| 6. HOSE COUPLING (EMERGENCY) | 14. COUPLING CHAIN          |
| 7. COUPLING ASSEMBLY         | 15. NONMETALLIC TUBE        |
| 8. COUPLING ASSEMBLY         | 16. ELBOW                   |

TA 237451

**BRAKE SYSTEM.**

<b>3-167. FRONT EXTERNAL AIR COUPLINGS REPLACEMENT (Continued).</b>		
<b>LOCATION/ITEM</b>	<b>ACTION</b>	<b>REMARKS</b>
<b><u>D. RIGHT-HAND COUPLINGS INSTALLATION.</u></b>		
28. Union (5). on threads.	Install in item (13).	Put thread sealing tape
29. Union (5) and coupling (13).	Put in place in item (11).	
30. Locknut (3) and washer (4).	Secure item (5) to item (11).	
31. Elbow (9). on threads.	Install in item (5).	Put thread sealing tape
32. Tube (10).	Install on item (9).	
33. Coupling assembly (8).	Install on item (13).	Make sure item (8) vents properly when air is released from system.
34. Chain (12).	Hook to item (11).	Use pliers.
<b>NOTE</b>		
<b>Follow-on maintenance action required:</b>		
Close air system draincocks and start engine (TM 9-2320-283-10). Check air system for leaks (para 3-8).		

**BRAKE SYSTEM.**

**3-167. FRONT EXTERNAL AIR COUPLINGS REPLACEMENT (Continued).**

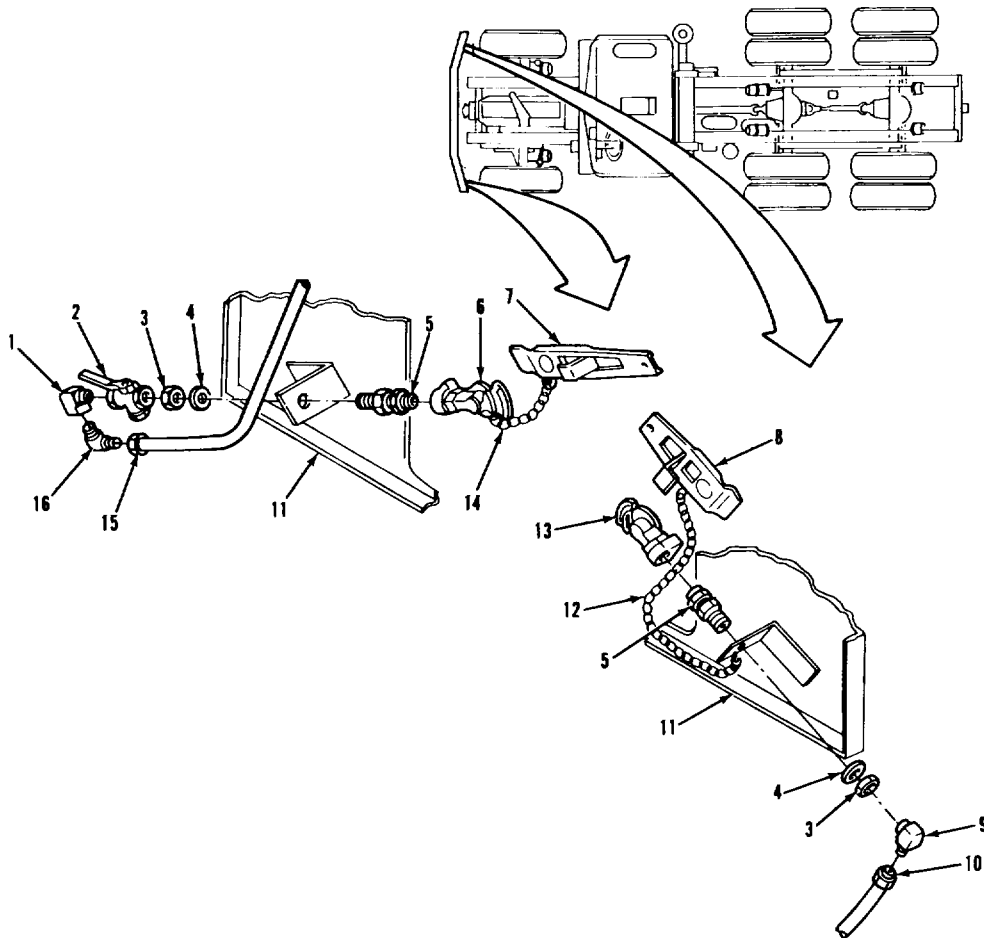

**LEGEND:**

- |                              |                             |
|------------------------------|-----------------------------|
| 1. ELBOW                     | 9. ELBOW                    |
| 2. CUTOUT COCK               | 10. NONMETALLIC TUBE        |
| 3. LOCKNUT (2)               | 11. FRONT BUMPER ASSEMBLY   |
| 4. WASHER (2)                | 12. COUPLING CHAIN          |
| 5. BULKHEAD UNION (2)        | 13. HOSE COUPLING (SERVICE) |
| 6. HOSE COUPLING (EMERGENCY) | 14. COUPLING CHAIN          |
| 7. COUPLING ASSEMBLY         | 15. NONMETALLIC TUBE        |
| 8. COUPLING ASSEMBLY         | 16. ELBOW                   |

TA 237452

**BRAKE SYSTEM.**

**3-168. SUPPLY RESERVOIR REPLACEMENT.**

**THIS TASK COVERS**

- a. Removal.
- b. Installation.

**INITIAL SETUP**

<p><u>APPLICABLE CONFIGURATIONS</u> All. open.</p>	<p><u>EQUIPMENT CONDITION PARAGRAPH</u> TM 9-2320-283-10.</p>	<p><u>CONDITION DESCRIPTION</u> Air system draincocks</p>
<p><u>TEST EQUIPMENT</u> None.</p>	<p>3-191.</p>	<p>Supply reservoir single check valve removed.</p>
<p><u>SPECIAL TOOLS</u> None.</p>		
<p><u>MATERIALS/PARTS (P/N)</u> Thread sealant, liquid Item 33, Appendix C.</p>		
<p><u>PERSONNEL REQUIRED</u> One (MOS-63S).</p>	<p><u>SPECIAL ENVIRONMENTAL CONDITIONS</u> None.</p>	
<p><u>REFERENCES (TM)</u> TM 9-2320-283-10.</p>	<p><u>GENERAL SAFETY INSTRUCTIONS</u> Engine off. Transmission in neutral. Park brake set.</p>	
<p><u>TROUBLESHOOTING REFERENCES</u> Paragraph 2-11.</p>		



BRAKE SYSTEM.

3-168. SUPPLY RESERVOIR REPLACEMENT (Continued).

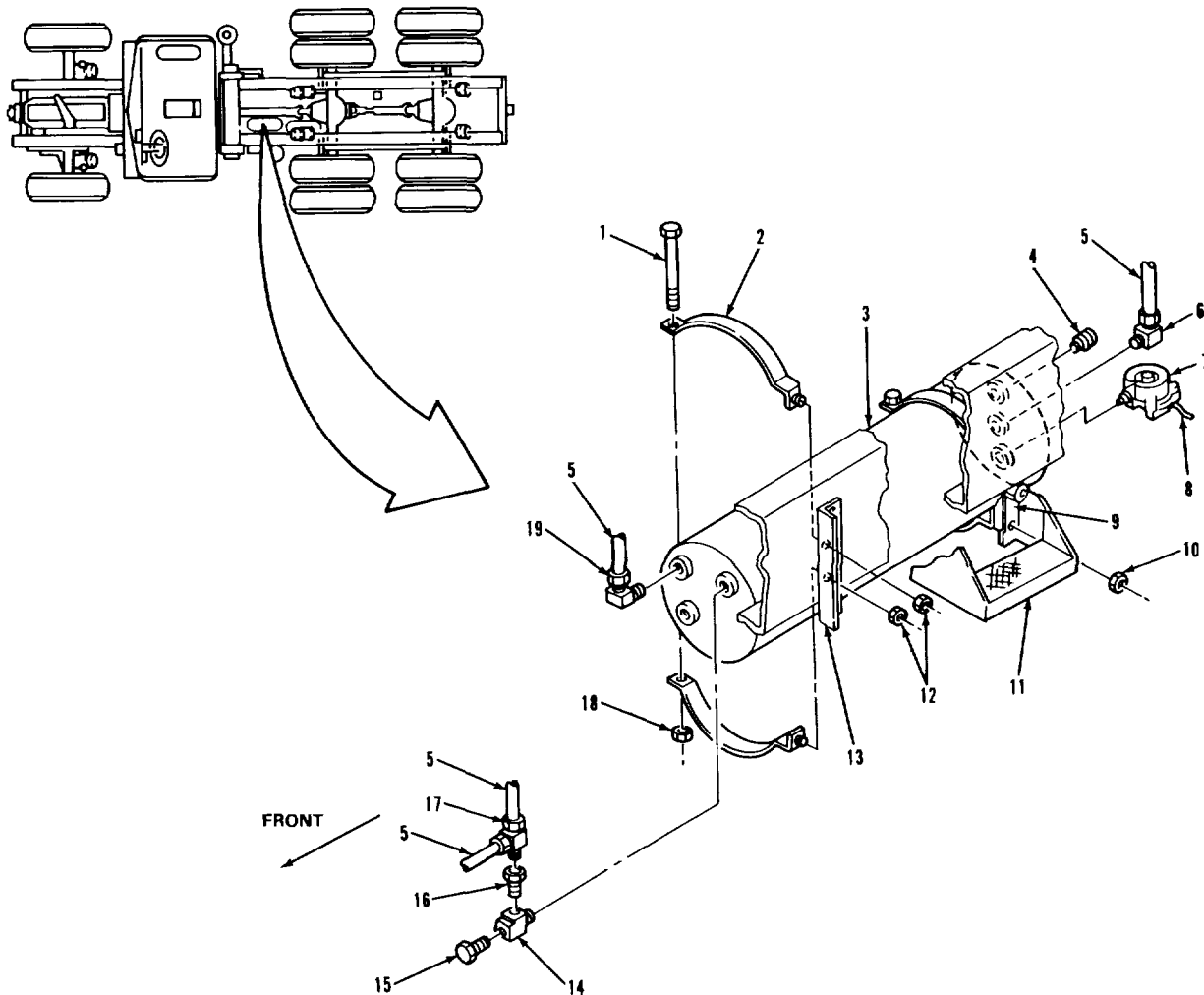

LEGEND:

- |                             |                     |
|-----------------------------|---------------------|
| 1. SCREW (2)                | 11. STEP            |
| 2. BRACKET (4)              | 12. NUT (2)         |
| 3. SUPPLY RESERVOIR         | 13. BRACKET         |
| 4. QUICK DISCONNECT COUPLER | 14. MALE STREET TEE |
| 5. AIR LINE (3)             | 15. SAFETY VALVE    |
| 6. ELBOW                    | 16. REDUCER BUSHING |
| 7. DRAIN VALVE              | 17. MALE RUN TEE    |
| 8. WIRE (89C)               | 18. NUT (2)         |
| 9. STEP BRACKET             | 19. ELBOW           |
| 10. NUT (2)                 |                     |

TA 237453

**BRAKE SYSTEM.**

<b>3-168. SUPPLY RESERVOIR REPLACEMENT (Continued).</b>		
<b>LOCATION/ITEM</b>	<b>ACTION</b>	<b>REMARKS</b>
<b><u>WARNING</u></b>		
<b>Never work on air system components without first draining air pressure. Failure to follow this precaution can result in serious personal injury.</b>		
<b><u>A. REMOVAL.</u></b>		
1. Wire (8).	Disconnect.	Quick release connector.
2. Three air lines (5).	Disconnect.	Tag for reassembly.
3. Two nuts (18).	Loosen and remove.	
4. Two screws (1).	Remove.	
5. Upper nut (10) and upper nut (12).	Remove from two upper items (2).	
6. Two upper brackets (2).	Remove from items (9) and (13).	
7. Supply reservoir (3).	Remove from two lower items (2).	Mark front of item (3) with chalk or tape.
8. Lower nut (10) and lower nut (12).	Remove frm two lower items (2).	
9. Two lower brackets (2).	Remove from items (9) and (13).	
10. Quick disconnect coupler (4) and elbow (6).	Remove from item (3).	
<b>3-978</b>		

**BRAKE SYSTEM.**

**3-168. SUPPLY RESERVOIR REPLACEMENT (Continued).**

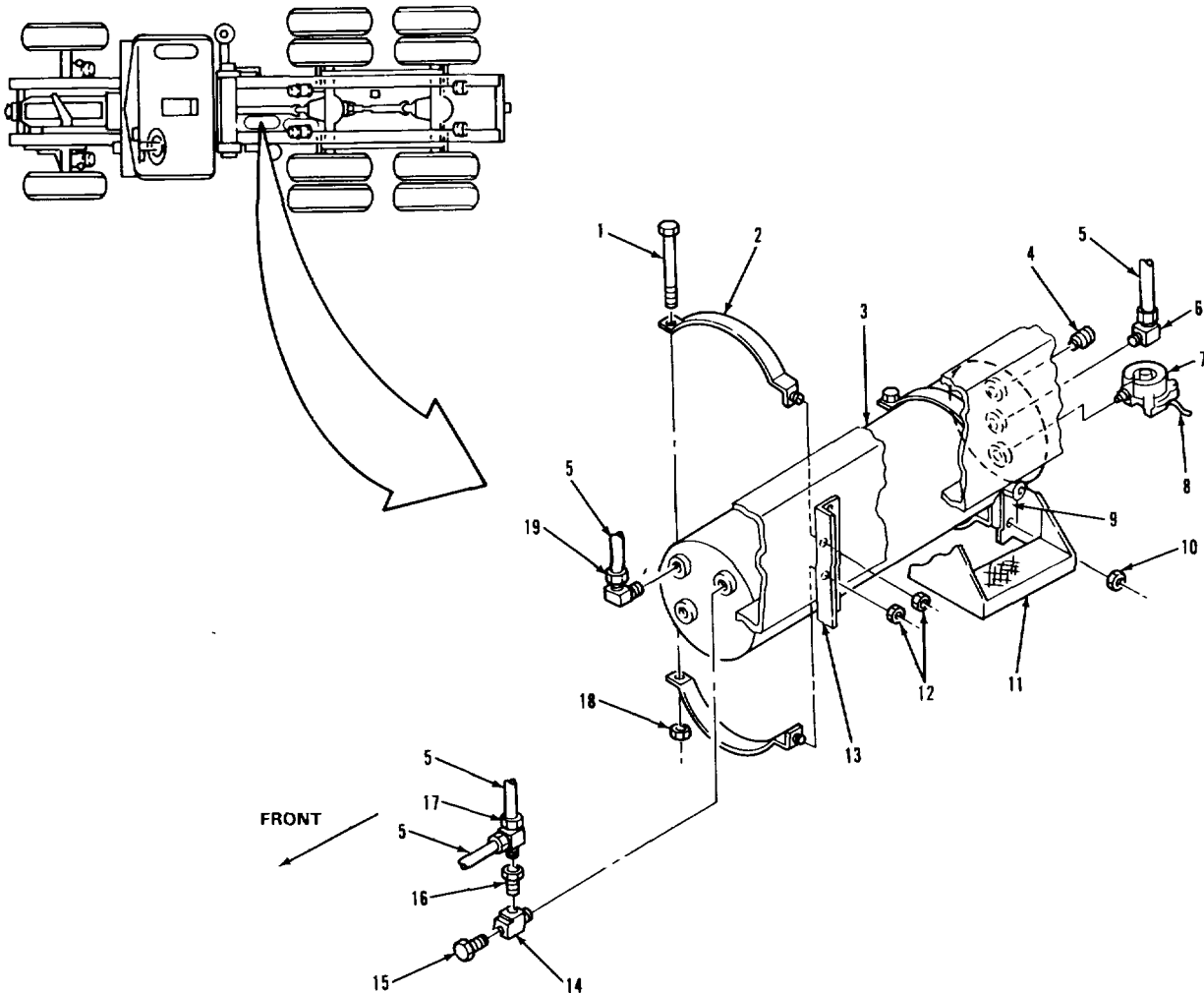

**LEGEND:**

- |                             |                     |
|-----------------------------|---------------------|
| 1. SCREW (2)                | 11. STEP            |
| 2. BRACKET (4)              | 12. NUT (2)         |
| 3. SUPPLY RESERVOIR         | 13. BRACKET         |
| 4. QUICK DISCONNECT COUPLER | 14. MALE STREET TEE |
| 5. AIR LINE (3)             | 15. SAFETY VALVE    |
| 6. ELBOW                    | 16. REDUCER BUSHING |
| 7. DRAIN VALVE              | 17. MALE RUN TEE    |
| 8. WIRE (89C)               | 18. NUT (2)         |
| 9. STEP BRACKET             | 19. ELBOW           |
| 10. NUT (2)                 |                     |

TA 237454

**BRAKE SYSTEM.****3-168. SUPPLY RESERVOIR REPLACEMENT (Continued).**

LOCATION/ITEM	ACTION	REMARKS
<b><u>B. INSTALLATION.</u></b>		
11. Drain valve (7).	Remove from item (3).	Refer to paragraph 3-192.
12. Elbow (19), male run tee (17), reducer bushing (16), safety valve (15), and male street tee (14).	Remove from item (3).	Refer to paragraph 3-188 for item (15) removal.
<b>NOTE</b>		
<b>Check air lines and fittings for leaks, cracks, and damaged threads. Replace if necessary. Be sure air lines are connected to the proper reservoir port when reconnecting.</b>		
13. Drain valve (7).	Coat threads with liquid thread sealant and install.	Refer to paragraph 3-192 for installation.
14. Quick disconnect coupler (4), elbow (6), elbow (24), male run tee (17), reducer bushing (16), safety valve (15), and male street tee (14).	Coat threads with liquid thread sealant and install.	Refer to paragraph 3-188 for item (15) installation.
15. Two lower brackets (2).	Move into position and align with lower mounting holes in items (13) and item (9).	
16. Nut (10) and nut (12).	Install on two lower items (2) and tighten.	

**BRAKE SYSTEM.**

**3-168. SUPPLY RESERVOIR REPLACEMENT (Continued).**

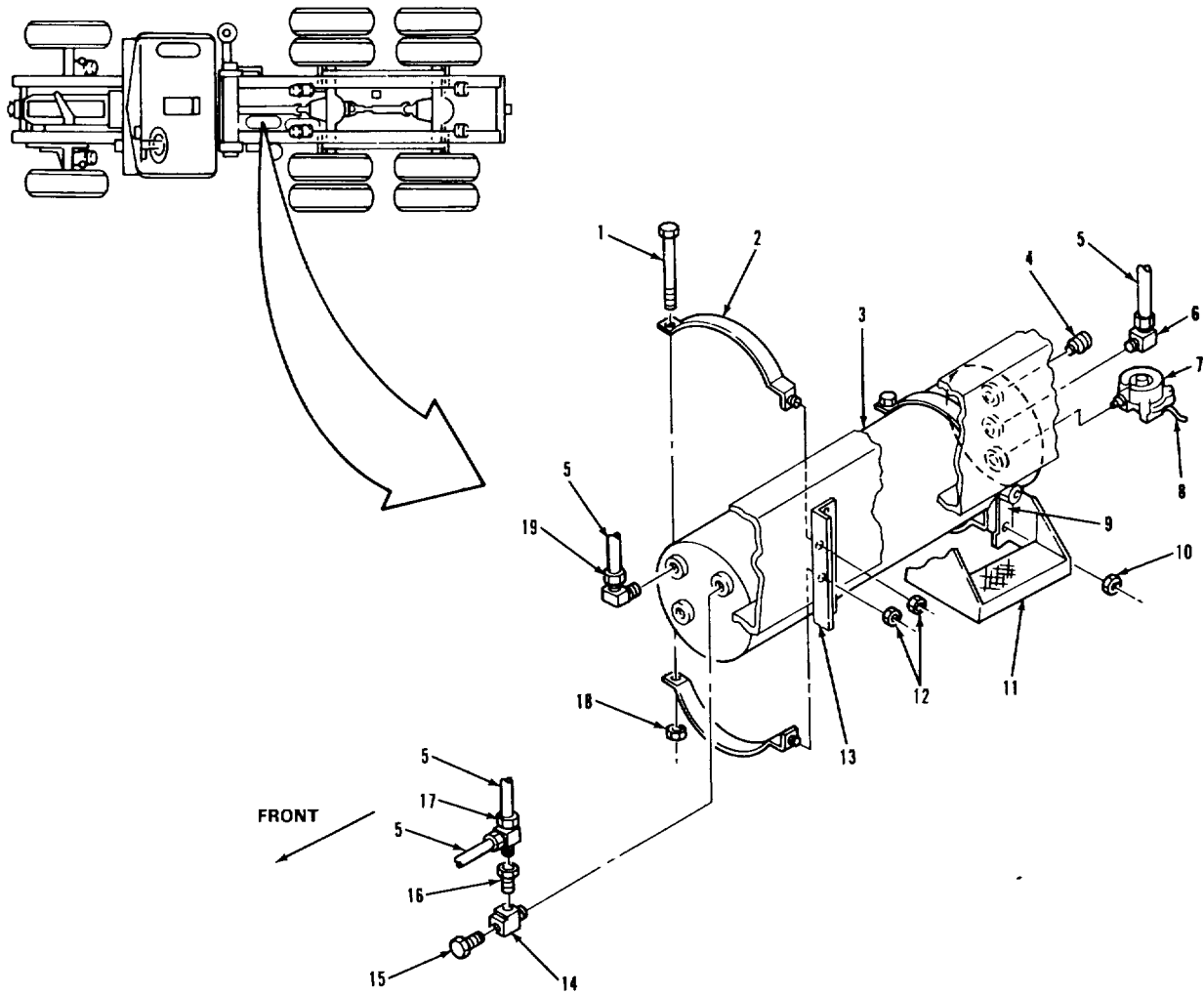

**LEGEND:**

- |                             |                     |
|-----------------------------|---------------------|
| 1. SCREW (2)                | 11. STEP            |
| 2. BRACKET (4)              | 12. NUT (2)         |
| 3. SUPPLY RESERVOIR         | 13. BRACKET         |
| 4. QUICK DISCONNECT COUPLER | 14. MALE STREET TEE |
| 5. AIR LINE (3)             | 15. SAFETY VALVE    |
| 6. ELBOW                    | 16. REDUCER BUSHING |
| 7. DRAIN VALVE              | 17. MALE RUN TEE    |
| 8. WIRE (89C)               | 18. NUT (2)         |
| 9. STEP BRACKET             | 19. ELBOW           |
| 10. NUT (2)                 |                     |

TA 237455

**BRAKE SYSTEM.**

<b>3-168. SUPPLY RESERVOIR REPLACEMENT (Continued).</b>		
<b>LOCATION/ITEM</b>	<b>ACTION</b>	<b>REMARKS</b>
<b><u>B. INSTALLATION (Continued).</u></b>		
17. Supply reservoir (3).	Place on two lower items (2).	
18. Two upper brackets (2).	Move into position and aline with upper mounting holes in items (13) and (9).	
19. Nut (10) and nut (12).	Install on two upper items (2) and tighten.	
20. Two screws (1).	Install in four items (2).	
21. Two nuts (18).	Install and tighten.	
22. Three air lines (5).	Install and tighten. identification tag.	Connect according to
23. Wire (8).	Connect.	
<b>NOTE</b>		
<b>Follow-on maintenance action required:</b>		
Install supply reservoir single check valve (para 3-191). Close air system draincocks and start engine (TM 9-2320-283-10). Check air system for leaks (para 3-8).		
<b>3-982</b>		

**BRAKE SYSTEM.**

**3-168. SUPPLY RESERVOIR REPLACEMENT (Continued).**

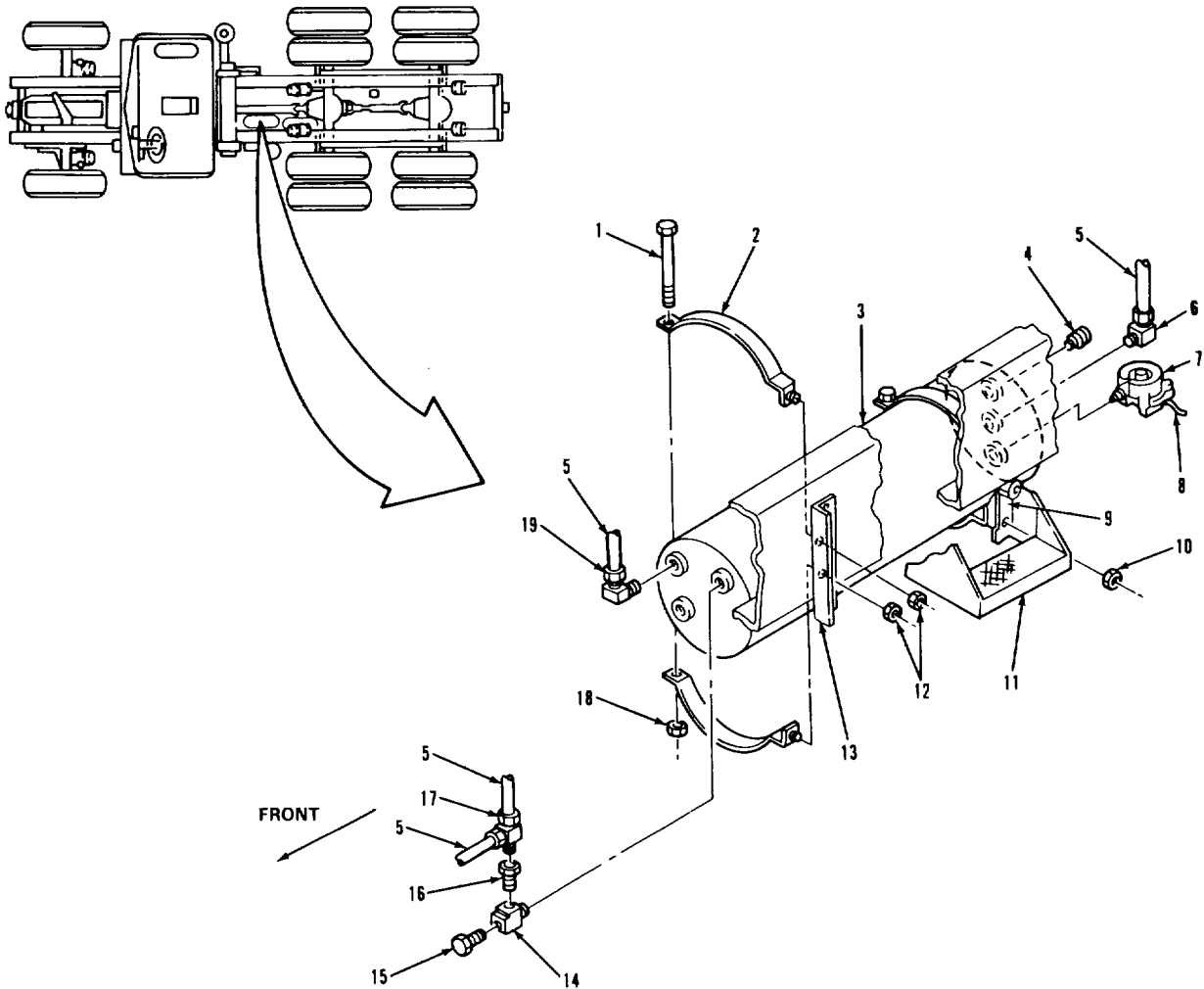

**LEGEND:**

- |                             |                     |
|-----------------------------|---------------------|
| 1. SCREW (2)                | 11. STEP            |
| 2. BRACKET (4)              | 12. NUT (2)         |
| 3. SUPPLY RESERVOIR         | 13. BRACKET         |
| 4. QUICK DISCONNECT COUPLER | 14. MALE STREET TEE |
| 5. AIR LINE (3)             | 15. SAFETY VALVE    |
| 6. ELBOW                    | 16. REDUCER BUSHING |
| 7. DRAIN VALVE              | 17. MALE RUN TEE    |
| 8. WIRE (89C)               | 18. NUT (2)         |
| 9. STEP BRACKET             | 19. ELBOW           |
| 10. NUT (2)                 |                     |

TA 237456

**BRAKE SYSTEM.**

**3-169. PRIMARY RESERVOIR REPLACEMENT.**

**THIS TASK COVERS**

- a. Removal.
- b. Installation.

**INITIAL SETUP**

<p><u>APPLICABLE CONFIGURATIONS</u> All.</p>	<p><u>EQUIPMENT CONDITION PARAGRAPH</u> TM 9-2320-283-10.</p>	<p><u>CONDITION DESCRIPTION</u> Air system draincocks open.</p>
<p><u>TEST EQUIPMENT</u> None.</p>	<p>3-239.</p>	<p>Service deck assembly removed.</p>
<p><u>SPECIAL TOOLS</u> None.</p>		
<p><u>MATERIALS/PARTS (P/N)</u> Thread sealant, liquid Item 33, Appendix C.</p>		
<p><u>PERSONNEL REQUIRED</u> One (MOS-63S).</p>	<p><u>SPECIAL ENVIRONMENTAL CONDITIONS</u> None.</p>	
<p><u>REFERENCES (TM)</u> TM 9-2320-283-10. Transmission in neutral. Park brake set.</p>	<p><u>GENERAL SAFETY INSTRUCTIONS</u> Engine off.</p>	
<p><u>TROUBLESHOOTING REFERENCES</u> Paragraph 2-11.</p>		



**BRAKE SYSTEM.**

**3-169. PRIMARY RESERVOIR REPLACEMENT (Continued).**

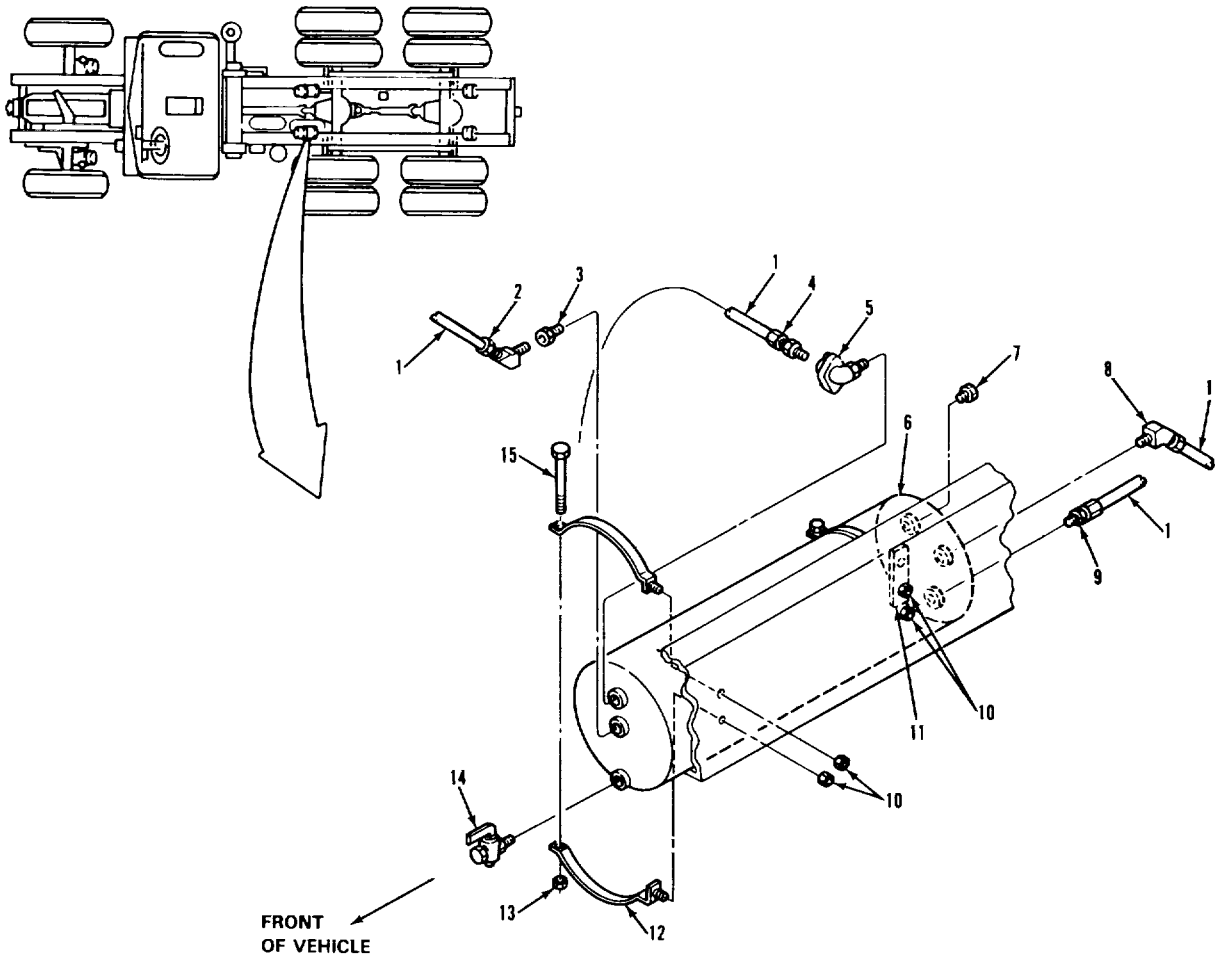

**LEGEND:**

- |                      |                 |
|----------------------|-----------------|
| 1. AIR LINE (4)      | 9. CONNECTOR    |
| 2. ELBOW             | 10. NUT (4)     |
| 3. REDUCER           | 11. TAB         |
| 4. CONNECTOR         | 12. BRACKET (4) |
| 5. CHECK VALVE       | 13. NUT (2)     |
| 6. PRIMARY RESERVOIR | 14. DRAINCOCK   |
| 7. PLUG              | 15. SCREW (2)   |
| 8. ELBOW             |                 |

TA 237457

**BRAKE SYSTEM.**

3-169. PRIMARY RESERVOIR REPLACEMENT (Continued).		
LOCATION/ITEM	ACTION	REMARKS
<b><u>WARNING</u></b>		
Never work on air system components without first draining air pressure. Failure to follow this precaution can result in serious personal injury.		
<b><u>A. REMOVAL.</u></b>		
1. Four air lines (1).	Disconnect.	Tag for reassembly.
2. Two nuts (13).	Loosen and remove.	
3. Two screws (15).	Remove.	
4. Two upper nuts (10) and brackets (12).	Remove.	
5. Primary reservoir (6).	Remove.	Mark front of item (6) with chalk or tape.
6. Two lower nuts (10) and brackets (12).	Remove.	
7. Tab (11).	Remove.	
8. Plug (7), connector (9), elbow (8), elbow (2), reducer (3), connector (4), check valve (5), and draincock (14).	Unscrew and remove from item (6).	
<b><u>B. INSTALLATION.</u></b>		
<b>NOTE</b>		
Check air lines and fittings for leaks, cracks, and damaged threads. Replace if necessary. Be sure air lines are connected to the proper reservoir port when reconnecting.		
3-986		

**BRAKE SYSTEM.**

**3-169. PRIMARY RESERVOIR REPLACEMENT (Continued).**

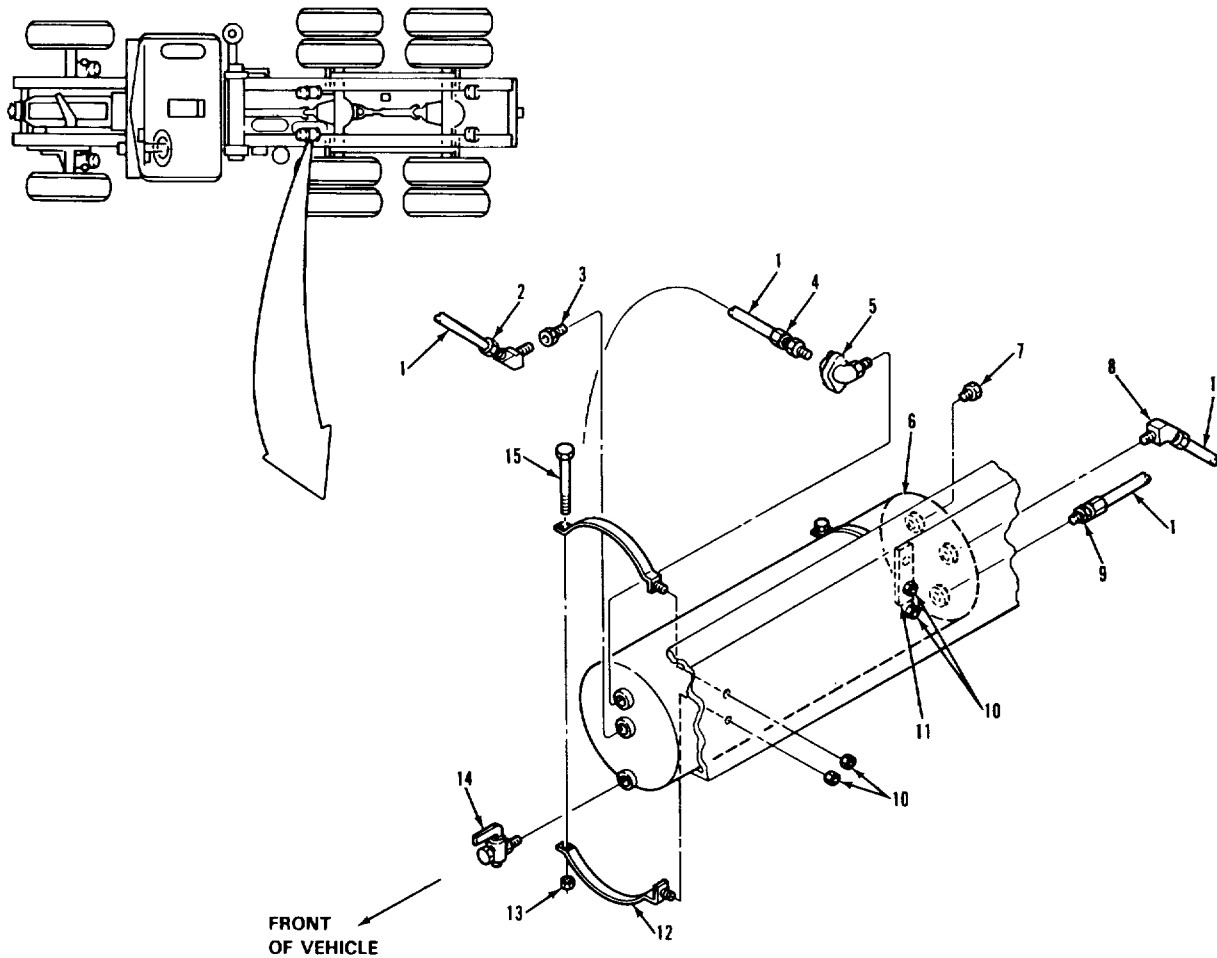

**LEGEND:**

- |                      |                 |
|----------------------|-----------------|
| 1. AIR LINE (4)      | 9. CONNECTOR    |
| 2. ELBOW             | 10. NUT (4)     |
| 3. REDUCER           | 11. TAB         |
| 4. CONNECTOR         | 12. BRACKET (4) |
| 5. CHECK VALVE       | 13. NUT (2)     |
| 6. PRIMARY RESERVOIR | 14. DRAINCOCK   |
| 7. PLUG              | 15. SCREW (2)   |
| 8. ELBOW             |                 |

TA 237458

**BRAKE SYSTEM.****3-169. PRIMARY RESERVOIR REPLACEMENT (Continued).**

LOCATION/ITEM	ACTION	REMARKS
<b><u>B. INSTALLATION (Continued).</u></b>		
9. Plug (7), connector (9), elbow (8), elbow (2), reducer (3), connector (4), check valve (5), and draincock (14).	Coat threads with liquid thread sealant and install in item (6).	
10. Two lower brackets (12) and nuts (10).	Install and secure in position on frame rail.	
11. Primary reservoir (6).	Put in place on two lower items (12).	
12. Two upper brackets (12) and tab (11).	Install on item (6) and frame rail.	
13. Two nuts (10) and (11).	Secure two upper items (12)	
14. Two screws (15) (12).	Install through four items	
15. Two nuts (13).	Install and tighten.	
16. Four air lines (1).	Install and tighten. identification tag.	Connect according to
<b>NOTE</b>		
<b>Follow-on maintenance action required:</b>		
Close air system draincocks and start engine (TM 9-2320-283-10). Check air system for leaks (para 3-8). Install service deck assembly (para 3-239).		
<b>3-988</b>		

**BRAKE SYSTEM.**

**3-169. PRIMARY RESERVOIR REPLACEMENT (Continued).**

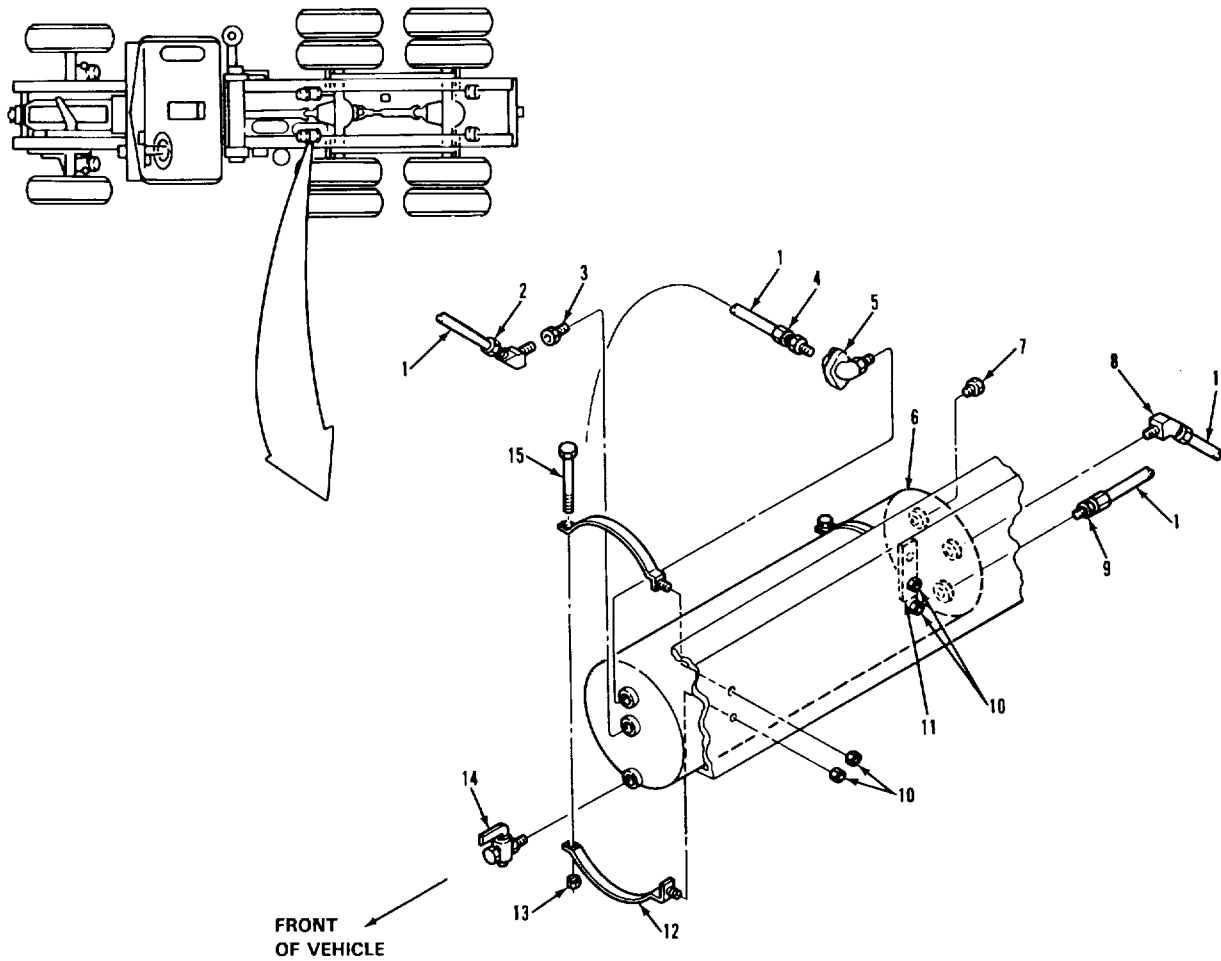

**LEGEND:**

- |                      |                 |
|----------------------|-----------------|
| 1. AIR LINE (4)      | 9. CONNECTOR    |
| 2. ELBOW             | 10. NUT (4)     |
| 3. REDUCER           | 11. TAB         |
| 4. CONNECTOR         | 12. BRACKET (4) |
| 5. CHECK VALVE       | 13. NUT (2)     |
| 6. PRIMARY RESERVOIR | 14. DRAINCOCK   |
| 7. PLUG              | 15. SCREW (2)   |
| 8. ELBOW             |                 |

TA 237459

**BRAKE SYSTEM.**

**3-170. SECONDARY RESERVOIR REPLACEMENT.**

**THIS TASK COVERS**

- a. Removal.
- b. Installation.

**INITIAL SETUP**

<p><u>APPLICABLE CONFIGURATIONS</u> All.</p>	<p><u>EQUIPMENT CONDITION PARAGRAPH</u> TM 9-2320-283-10.</p>	<p><u>CONDITION DESCRIPTION</u> Air system draincocks open.</p>
<p><u>TEST EQUIPMENT</u> None.</p>		
<p><u>SPECIAL TOOLS</u> None.</p>		
<p><u>MATERIALS/PARTS (P/N)</u> Thread sealant, liquid Item 33, Appendix C.</p>		
<p><u>PERSONNEL REQUIRED</u> One (MOS-63S).</p>	<p><u>SPECIAL ENVIRONMENTAL CONDITIONS</u> None.</p>	
<p><u>REFERENCES (TM)</u> TM 9-2320-283-10. Transmission in neutral. Park brake set.</p>	<p><u>GENERAL SAFETY INSTRUCTIONS</u> Engine off.</p>	
<p><u>TROUBLESHOOTING REFERENCES</u> Paragraph 2-11.</p>		

**BRAKE SYSTEM.**

**3-170. SECONDARY RESERVOIR REPLACEMENT (Continued).**

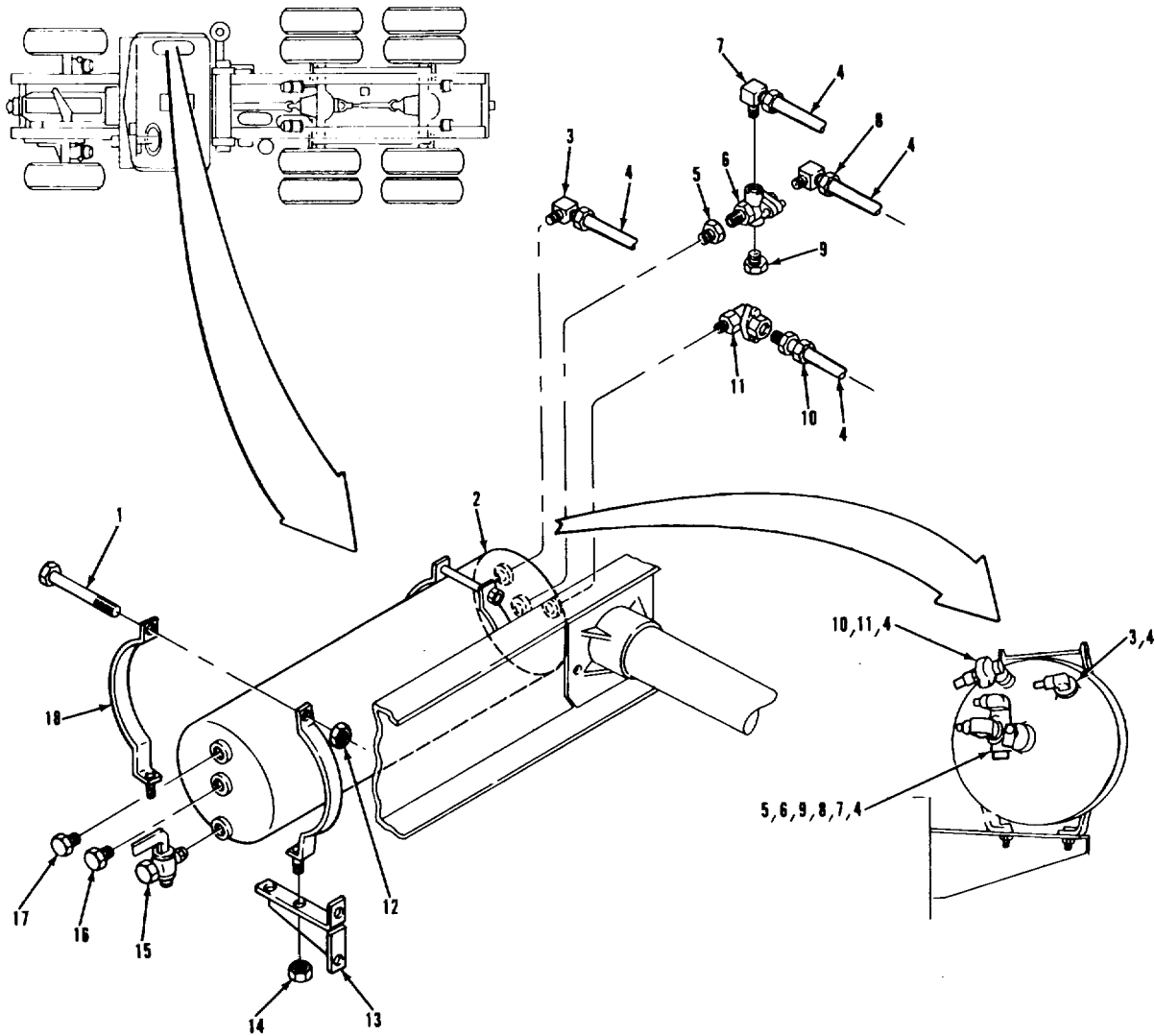

**LEGEND:**

- 1. SCREW (2)
- 2. SECONDARY RESERVOIR
- 3. ELBOW
- 4. AIR LINE (4)
- 5. REDUCER
- 6. DOUBLE CHECK VALVE
- 7. ELBOW
- 8. ELBOW
- 9. PLUG

- 10. CONNECTOR
- 11. CHECK VALVE
- 12. NUT (2)
- 13. AIR TANK SUPPORT (2)
- 14. NUT (14)
- 15. DRAINCOCK
- 16. PLUG
- 17. PLUG
- 18. BRACKET (4)

TA 237460

**BRAKE SYSTEM.****3-170. SECONDARY RESERVOIR REPLACEMENT (Continued).**

LOCATION/ITEM	ACTION	REMARKS
<b><u>WARNING</u></b>		
<b>Never work on air system components without first draining air pressure. Failure to follow this precaution can result in serious personal injury.</b>		
<b><u>A. REMOVAL.</u></b>		
1. Four air lines (4).	Remove.	Tag for reassembly.
2. Secondary reservoir (2).	Scribe a line a top dead center and mark location of four items (18).	Aids in reinstallation.
3. Two screws (1) and two nuts (12).	Loosen.	
4. Four nuts (14).	Loosen and remove.	
5. Secondary reservoir (2) with four brackets (18).	Lift up and remove from two items (13).	
6. Four brackets (18).	Slide off.	
7. Two screws (1) and two nuts (12).	Remove from four items (18).	
8. Draincock (15), plug (16), and plug (17).	Remove.	
9. Elbow (7), elbow (8), elbow (3), connector (10), plug (9), check valve (11), double check valve (6), and reducer (5).	Remove.	
<b>3-992</b>		



BRAKE SYSTEM.

3-170. SECONDARY RESERVOIR REPLACEMENT (Continued).

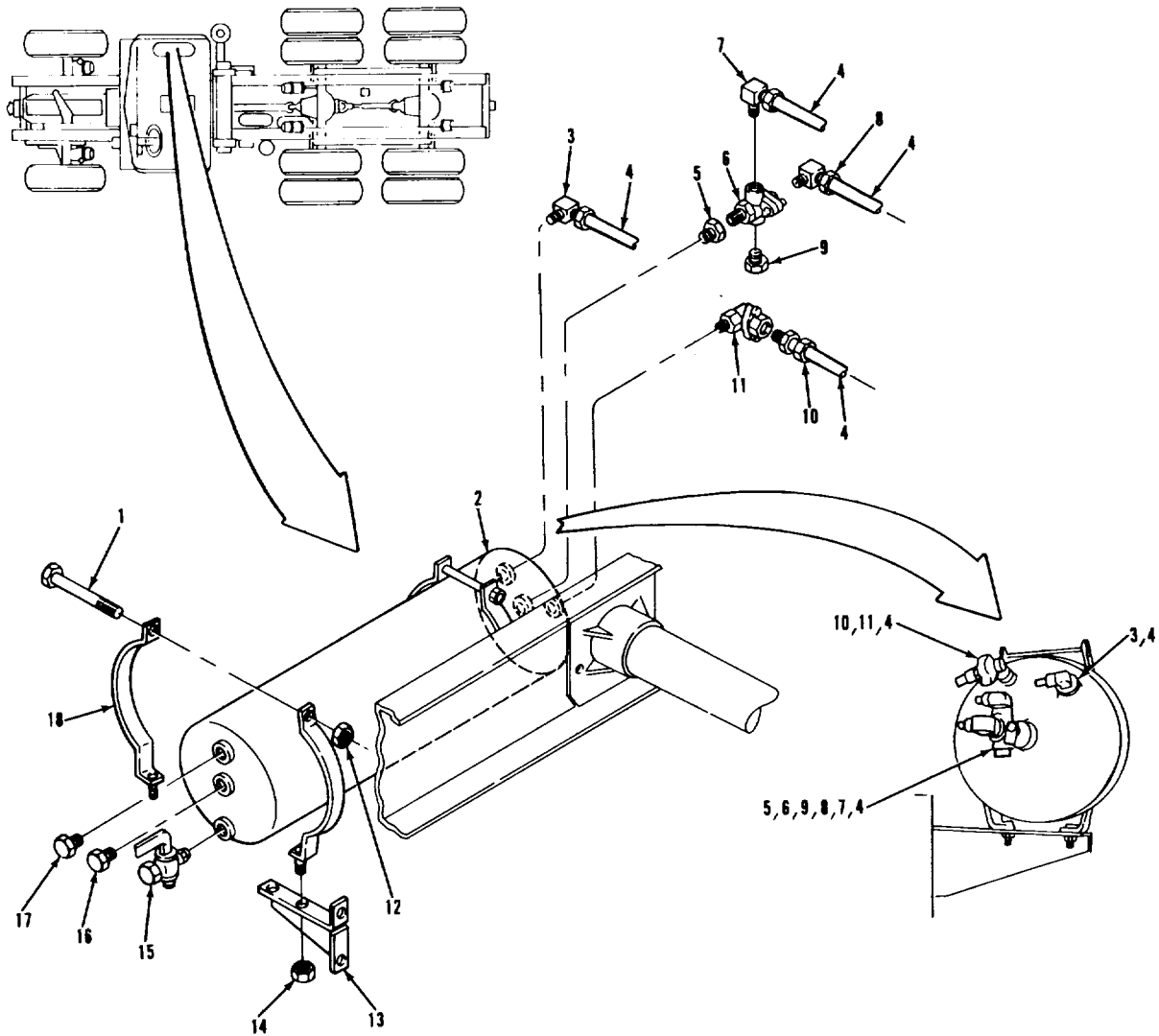

LEGEND:

- |                        |                          |
|------------------------|--------------------------|
| 1. SCREW (2)           | 10. CONNECTOR            |
| 2. SECONDARY RESERVOIR | 11. CHECK VALVE          |
| 3. ELBOW               | 12. NUT (2)              |
| 4. AIR LINE (4)        | 13. AIR TANK SUPPORT (2) |
| 5. REDUCER             | 14. NUT (14)             |
| 6. DOUBLE CHECK VALVE  | 15. DRAINCOCK            |
| 7. ELBOW               | 16. PLUG                 |
| 8. ELBOW               | 17. PLUG                 |
| 9. PLUG                | 18. BRACKET (4)          |

TA 237461

**BRAKE SYSTEM.**

3-170. SECONDARY RESERVOIR REPLACEMENT (Continued).		
LOCATION/ITEM	ACTION	REMARKS
<b><u>B. INSTALLATION.</u></b>		
<b>NOTE</b>		
<b>Check air lines and fittings for leaks, cracks, and damaged threads. Replace if necessary. Be sure air lines are connected to the proper reservoir port when reconnecting.</b>		
10. Elbow (7), elbow (8), elbow (3), connector (10), plug (9), check valve (11), double check valve (6), and reducer (5).	Coat threads with liquid thread sealant and install.	
11. Draincock (15), plug (16), and plug (17).	Coat threads with liquid thread sealant and install.	
12. Four brackets (18).	Install two items (1) and two items (12) and slide onto item (2).	Use alinement marks made in step 2. Do not tighten items (1) and (12).
13. Secondary reservoir (2) with four brackets (18).	Install on two items (13).	
14. Four nuts (14).	Install and tighten.	
15. Two screws (1) and two nuts (12).	Tighten.	
16. Four air lines (4). identification tag.	Install and tighten.	Connect according to
<b>NOTE</b>		
<b>Follow-on maintenance action required:</b>		
Close air system draincocks and start engine (TM 9-2320-283-10). Check air system for leaks (para 3-8).		
<b>3-994</b>		

BRAKE SYSTEM.

3-170. SECONDARY RESERVOIR REPLACEMENT (Continued).

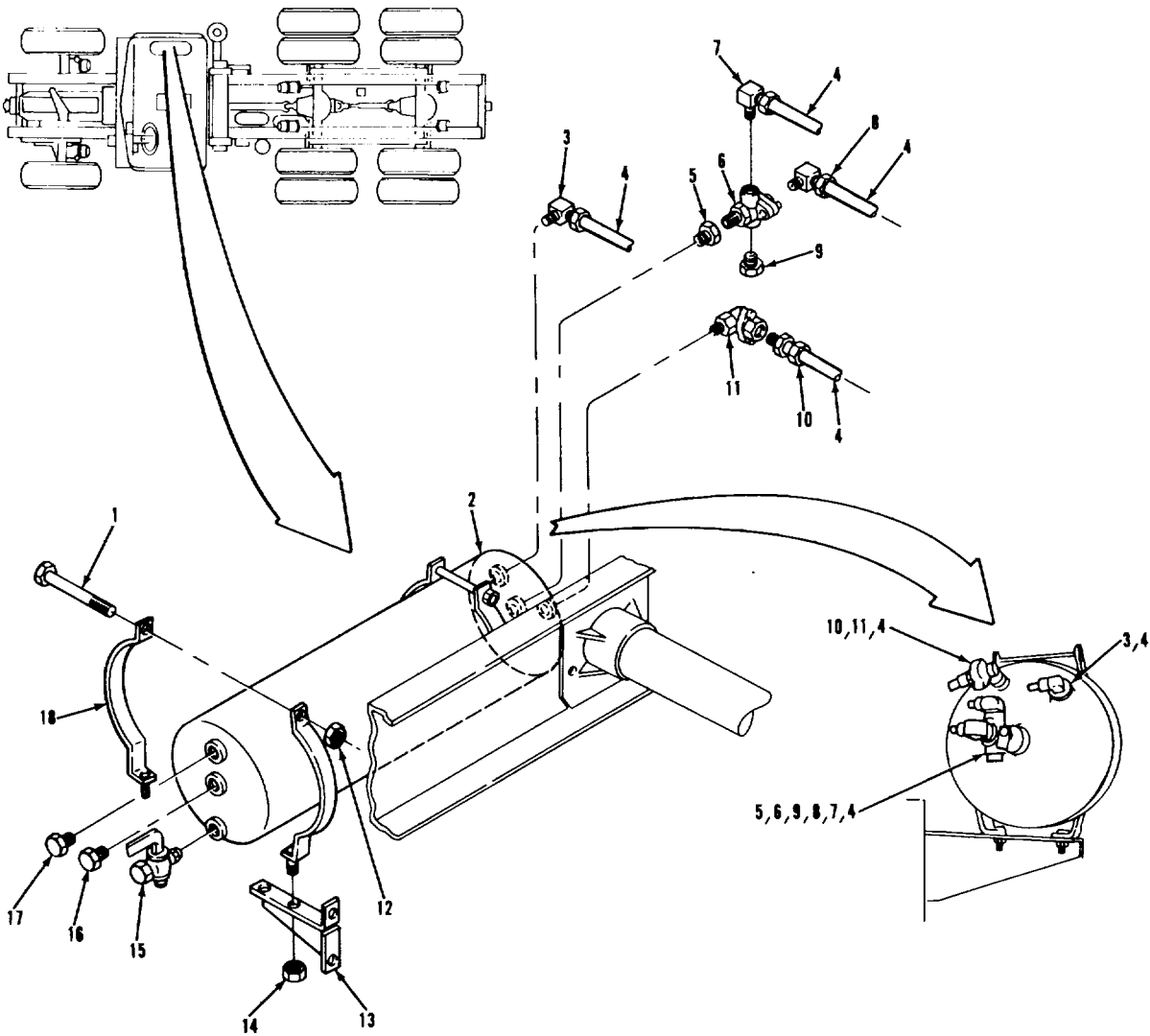

LEGEND:

- |                        |                          |
|------------------------|--------------------------|
| 1. SCREW (2)           | 10. CONNECTOR            |
| 2. SECONDARY RESERVOIR | 11. CHECK VALVE          |
| 3. ELBOW               | 12. NUT (2)              |
| 4. AIR LINE (4)        | 13. AIR TANK SUPPORT (2) |
| 5. REDUCER             | 14. NUT (14)             |
| 6. DOUBLE CHECK VALVE  | 15. DRAINCOCK            |
| 7. ELBOW               | 16. PLUG                 |
| 8. ELBOW               | 17. PLUG                 |
| 9. PLUG                | 18. BRACKET (4)          |

TA 237462

**BRAKE SYSTEM.**

**3-171. PARK BRAKE VALVE REPLACEMENT.**

**THIS TASK COVERS**

- a. Removal.
- b. Cleaning and Inspection.
- c. Installation.

**INITIAL SETUP**

<p><u>APPLICABLE CONFIGURATIONS</u> All.</p>	<p><u>EQUIPMENT CONDITION PARAGRAPH</u> 3-120.</p>	<p><u>CONDITION DESCRIPTION</u> Battery power disconnected.</p>
<p><u>TEST EQUIPMENT</u> None.</p>	<p>TM 9-2320-283-10.  3-114.</p>	<p>Air system draincocks open. Manual reset circuit breaker mounting bracket removed.</p>
<p><u>SPECIAL TOOLS</u> None.</p>		
<p><u>MATERIALS/PARTS (P/N)</u> Tape, thread sealing Item 32, Appendix C.</p>		
<p><u>PERSONNEL REQUIRED</u> One (MOS-63S).</p>	<p><u>SPECIAL ENVIRONMENTAL CONDITIONS</u> None.</p>	
<p><u>REFERENCES (TM)</u> TM 9-2320-283-10.</p>	<p><u>GENERAL SAFETY INSTRUCTIONS</u> Engine off. Transmission in neutral. Park brake set.</p>	
<p><u>TROUBLESHOOTING REFERENCES</u> Paragraph 2-11.</p>		

**BRAKE SYSTEM.**

**3-171. PARK BRAKE VALVE REPLACEMENT (Continued).**

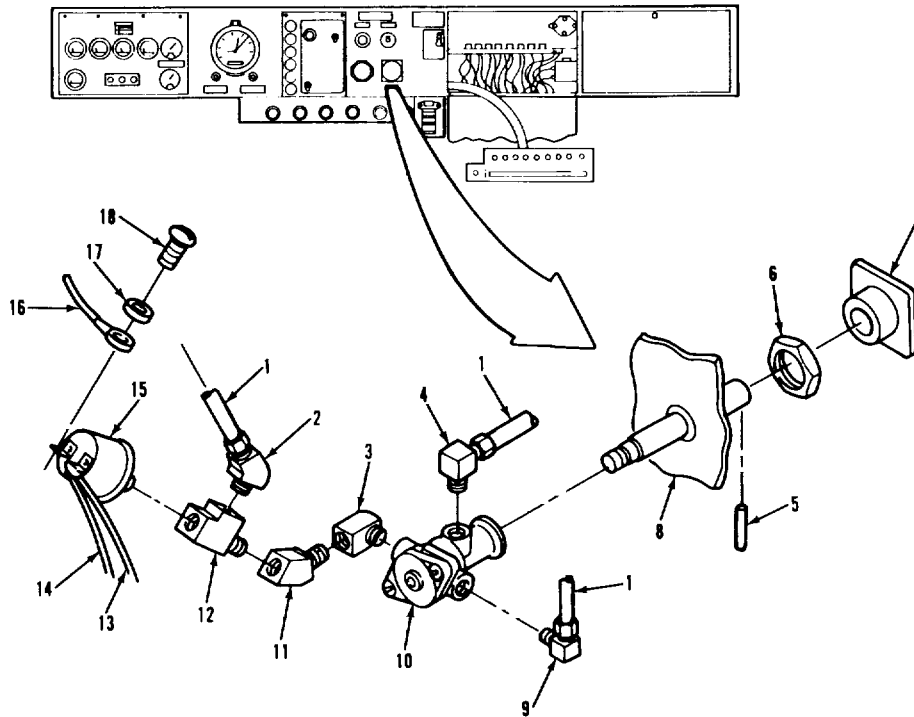

**LEGEND:**

- |                     |                               |
|---------------------|-------------------------------|
| 1. AIR LINE (3)     | 10. PARK BRAKE VALVE ASSEMBLY |
| 2. 45° ELBOW        | 11. STREET ELBOW              |
| 3. 90° ELBOW        | 12. STREET TEE                |
| 4. ELBOW            | 13. WIRE (44F)                |
| 5. PIN              | 14. WIRE (44G)                |
| 6. NUT              | 15. PRESSURE SWITCH           |
| 7. KNOB             | 16. WIRE (53D)                |
| 8. INSTRUMENT PANEL | 17. WASHER (2)                |
| 9. ELBOW            | 18. SCREW (2)                 |

TA 23746

**BRAKE SYSTEM.**

<b>3-171. PARK BRAKE VALVE REPLACEMENT (Continued).</b>		
<b>LOCATION/ITEM</b>	<b>ACTION</b>	<b>REMARKS</b>
<b><u>WARNING</u></b>		
Never work on air system components without first draining air pressure. Failure to follow this precaution can result in serious personal injury.		
<b><u>A. REMOVAL.</u></b>		
1. Two screws (18) and washers (17).	Remove.	
2. Wire (13), wire (14), and wire (16).	Remove.	Tag for identification. Item (13) and item (14) share a common terminal.
3. Three air lines (1).	Remove.	Tag.
4. Pin (5).	Remove from item (7).	Use small drift.
5. Knob (7).	Remove.	Pull off.
6. Nut (6).	Loosen and remove.	
7. Park brake valve assembly (10).	Remove from item (8).	
8. Pressure switch (15).	Remove.	
9. Elbow (9) and elbow (4).	Remove.	
10. 45° elbow (2), street tee (12), street elbow (11), and 90° elbow (3).	Remove.	
<b><u>B. CLEANING AND INSPECTION.</u></b>		
11. All parts and 3-5.	Clean and inspect.	Refer to paragraphs 3-4

**BRAKE SYSTEM.**

**3-171. PARK BRAKE VALVE REPLACEMENT (Continued).**

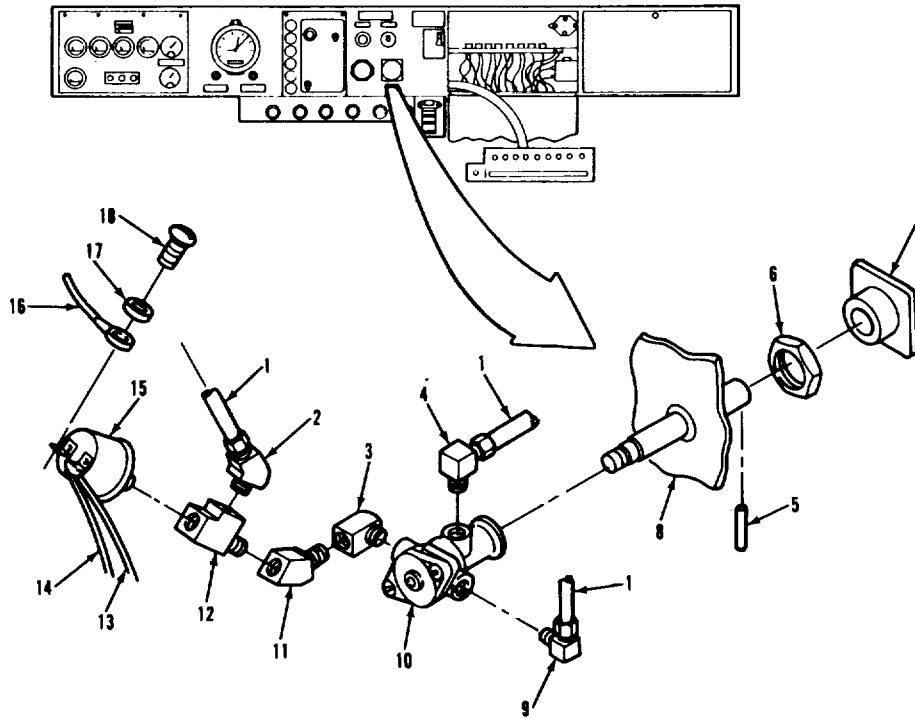

**LEGEND:**

- |                     |                               |
|---------------------|-------------------------------|
| 1. AIR LINE (3)     | 10. PARK BRAKE VALVE ASSEMBLY |
| 2. 45° ELBOW        | 11. STREET ELBOW              |
| 3. 90° ELBOW        | 12. STREET TEE                |
| 4. ELBOW            | 13. WIRE (44F)                |
| 5. PIN              | 14. WIRE (44G)                |
| 6. NUT              | 15. PRESSURE SWITCH           |
| 7. KNOB             | 16. WIRE (53D)                |
| 8. INSTRUMENT PANEL | 17. WASHER (2)                |
| 9. ELBOW            | 18. SCREW (2)                 |

TA 23746

**BRAKE SYSTEM.****3-171. PARK BRAKE VALVE REPLACEMENT (Continued).**

LOCATION/ITEM	ACTION	REMARKS
<b><u>C. INSTALLATION.</u></b>		
12. 450 elbow (2), street tee (12), street elbow (11), and 900 elbow (3).	Install on item (10) on threads.	Use thread sealing tape
13. Pressure switch (15).	Install on item (12) on threads.	Use thread sealing tape
14. Elbow (4) and elbow (9).	Install on item (10) on threads.	Use thread sealing tape
15. Park brake valve assembly (10).	Aline with mounting hole in item (8) and install.	
16. Nut (6).	Install and tighten.	
17. Knob (7). (5).	Install and secure with item	
18. Three air lines (1).	Install and tighten.	
19. Wire (13), wire (14), and wire (16).	Connect using two items (17) and two items (18).	
20. Three air lines (1).	Install and tighten.	
<b>NOTE</b>		
<b>Follow-on maintenance action required:</b>		
Install manual reset circuit breaker bracket (para 3-114). Connect battery power (para 3-120). Close air system draincocks and start engine (TM 9-2320-283-10). Check air system for leaks (para 3-8).		
<b>3-1000</b>		



**BRAKE SYSTEM.**

**3-171. PARK BRAKE VALVE REPLACEMENT (Continued).**

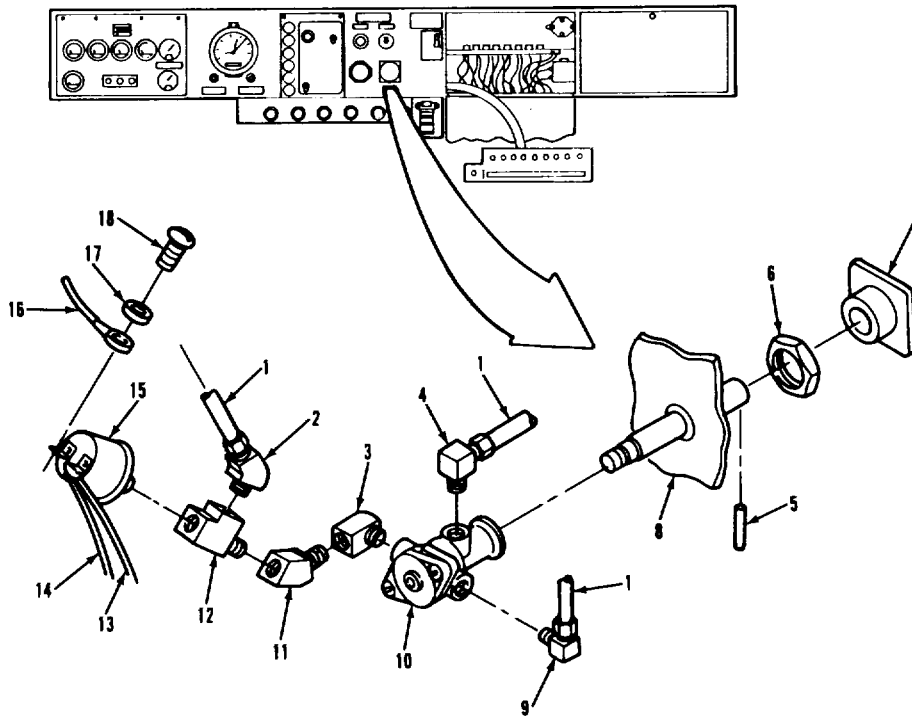

**LEGEND:**

- |                     |                               |
|---------------------|-------------------------------|
| 1. AIR LINE (3)     | 10. PARK BRAKE VALVE ASSEMBLY |
| 2. 45° ELBOW        | 11. STREET ELBOW              |
| 3. 90° ELBOW        | 12. STREET TEE                |
| 4. ELBOW            | 13. WIRE (44F)                |
| 5. PIN              | 14. WIRE (44G)                |
| 6. NUT              | 15. PRESSURE SWITCH           |
| 7. KNOB             | 16. WIRE (53D)                |
| 8. INSTRUMENT PANEL | 17. WASHER (2)                |
| 9. ELBOW            | 18. SCREW (2)                 |

TA 237465

**BRAKE SYSTEM.**

**3-172. PARK BRAKE VALVE REPAIR.**

**THIS TASK COVERS**

- a. Disassembly.
- b. Cleaning and Inspection.
- c. Reassembly.

**INITIAL SETUP**

APPLICABLE CONFIGURATIONS

All.

EQUIPMENT CONDITION

PARAGRAPH

3-171.

CONDITION DESCRIPTION

Park brake valve removed.

TEST EQUIPMENT

None.

SPECIAL TOOLS

None.

MATERIALS/PARTS (P/N)

Grease, silicone, lubrication

Item 9, Appendix C.

Compound, thread locking

Item 10, Appendix C.

Kit, seal

(78330) 1069.

PERSONNEL REQUIRED

One (MOS-63S).

SPECIAL ENVIRONMENTAL CONDITIONS

None.

REFERENCES (TM)

TM 9-2320-283-20P.

GENERAL SAFETY INSTRUCTIONS

Wear eye protection.

TROUBLESHOOTING REFERENCES

Paragraph 2-11.

**BRAKE SYSTEM.**  
**3-172. PARK BRAKE VALVE REPAIR (Continued).**

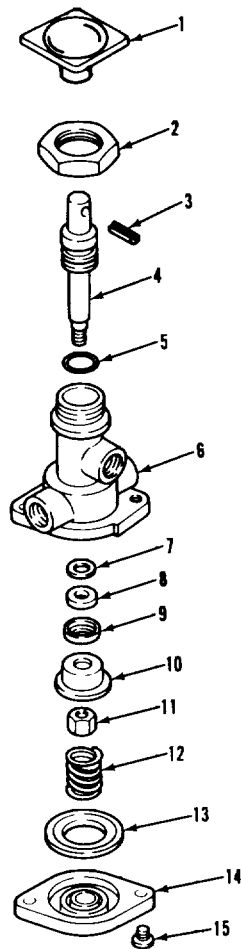

**LEGEND:**

- |                |                  |
|----------------|------------------|
| 1. KNOB        | 9. SEAL CUP      |
| 2. NUT         | 10. SPRING PLATE |
| 3. PIN         | 11. NUT          |
| 4. SHAFT       | 12. SPRING       |
| 5. O-RING SEAL | 13. COVER SEAL   |
| 6. VALVE BODY  | 14. COVER        |
| 7. WASHER      | 15. SCREW (2)    |
| 8. SEAL        |                  |

TA 237466

**BRAKE SYSTEM.**

**3-172. PARK BRAKE VALVE REPAIR (Continued).**

LOCATION/ITEM	ACTION	REMARKS
---------------	--------	---------

**CAUTION**

The valve body and/or cover cannot be clamped in a vise. Failure to heed caution will result in damage to park brake valve.

**A. DISASSEMBLY.**

**WARNING**

Cover is under spring force. Wear eye protection when removing cover and spring. Failure to heed warning can result in personnel injury.

**NOTE**

Nut (2) is used to secure valve to instrument panel.

1 Two screws (15)	Hold item (14) and remove two items (15)	Item (14) is under spring force.
2 Cover (14), cover seal (13), and spring (12).	Remove	Discard item (13).
3 Knob (1)	Install on item (4) and insert rod through pinhole	Prevents rotation of item (4) when removing item (11).
4 Nut (11)	Unscrew and remove from item (4).	
5 Spring plate (10), seal cup (9), seal (8), and washer (7)	Remove from item (4)	Discard item (9), item (8), and item (7).

**3-1004**

**BRAKE SYSTEM.**  
**3-172. PARK BRAKE VALVE REPAIR (Continued).**

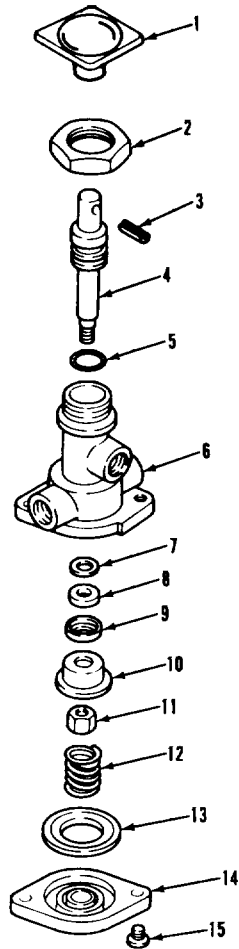

**LEGEND:**

- |                |                  |
|----------------|------------------|
| 1. KNOB        | 9. SEAL CUP      |
| 2. NUT         | 10. SPRING PLATE |
| 3. PIN         | 11. NUT          |
| 4. SHAFT       | 12. SPRING       |
| 5. O-RING SEAL | 13. COVER SEAL   |
| 6. VALVE BODY  | 14. COVER        |
| 7. WASHER      | 15. SCREW (2)    |
| 8. SEAL        |                  |

TA 237467

**BRAKE SYSTEM.**

**3-172. PARK BRAKE VALVE REPAIR (Continued).**

LOCATION/ITEM	ACTION	REMARKS
<b><u>A. DISASSEMBLY (Continued).</u></b>		
6 Shaft (4)	Remove from item (6).	
7 Knob (1)	Remove from item (4).	
8 O-ring seal (5)	Remove from item (4)	Discard item (5).
<b><u>B CLEANING AND INSPECTION</u></b>		
9 All parts	Clean and inspect	Refer to paragraphs 3-4 and 3-5.
<b><u>C REASSEMBLY</u></b>		
10 O-ring seal (5)	Grease and install on item (4).	Use silicone grease.
11 Valve body (6)	Grease bore in area of item (5) and the seating surface of item (8).	
12 Shaft (4)	Grease and install in item (6).	
13 Washer (7)	Install on step of item (4).	
14 Seal cup (9) and seal (8)	Assemble, grease, and install onto step of item (4)	Item (8) facing item (7).
15 Spring plate (10)	Install on step of item (4) with the open end towards item (14).	

**3-1006**

**BRAKE SYSTEM.**

**3-172. PARK BRAKE VALVE REPAIR (Continued).**

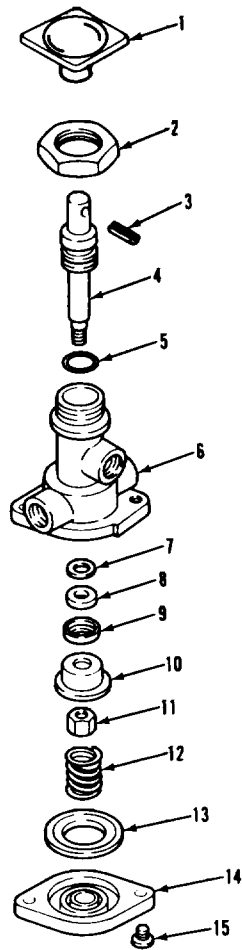

**LEGEND:**

- |                |                  |
|----------------|------------------|
| 1. KNOB        | 9. SEAL CUP      |
| 2. NUT         | 10. SPRING PLATE |
| 3. PIN         | 11. NUT          |
| 4. SHAFT       | 12. SPRING       |
| 5. O-RING SEAL | 13. COVER SEAL   |
| 6. VALVE BODY  | 14. COVER        |
| 7. WASHER      | 15. SCREW (2)    |
| 8. SEAL        |                  |

TA 237468

**BRAKE SYSTEM.**

**3-172. PARK BRAKE VALVE REPAIR (Continued).**

LOCATION/ITEM	ACTION	REMARKS
<b><u>C. REASSEMBLY (Continued). I</u></b>		
<b>NOTE</b>		
The nut must be torqued for the park brake valve to operate.		
16 Nut (11)	Apply thread locking compound and install on item (4) Tighten to 38 lb-in	Make sure item (10) is centered on item (4). Recenter if necessary. Install item (1) with rod through pinhole to prevent item (4) from turning.
17 Cover seal (13)	Install with rubber surface facing in and steel insert side facing item (12). Grease sealing surfaces.	
18 Spring plate (10) and cover seal (13).		
19 Spring (12)	Install.	
20 Cover (14)	Install and secure with two items (15).	
<b>NOTE</b>		
Follow-on maintenance action required:		
Install park brake valve (para 3-171).		
<b>3-1008</b>		



**BRAKE SYSTEM.**  
**3-172. PARK BRAKE VALVE REPAIR (Continued).**

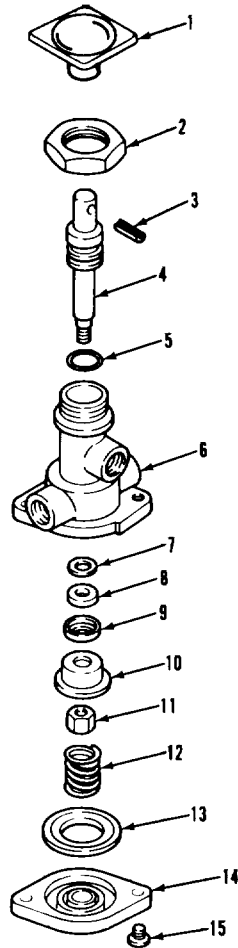

**LEGEND:**

- |                |                  |
|----------------|------------------|
| 1. KNOB        | 9. SEAL CUP      |
| 2. NUT         | 10. SPRING PLATE |
| 3. PIN         | 11. NUT          |
| 4. SHAFT       | 12. SPRING       |
| 5. O-RING SEAL | 13. COVER SEAL   |
| 6. VALVE BODY  | 14. COVER        |
| 7. WASHER      | 15. SCREW (2)    |
| 8. SEAL        |                  |

TA 237469

**BRAKE SYSTEM.**

**3-173. TRAILER HAND BRAKE VALVE REPLACEMENT.**

THIS TASK COVERS

- |    |               |    |                    |
|----|---------------|----|--------------------|
| a. | Removal.      | d. | Operational Check. |
| b. | Inspection.   | e. | Adjustment.        |
| c. | Installation. |    |                    |

INITIAL SETUP

<p><u>APPLICABLE CONFIGURATIONS</u> All.</p> <p><u>TEST EQUIPMENT</u> Gage, air pressure, 0-200 psi.</p> <p><u>SPECIAL TOOLS</u> Tape, thread sealing Item 32, Appendix C.</p> <p><u>MATERIALS/PARTS (P/N)</u> None.</p> <p><u>PERSONNEL REQUIRED</u> One (MOS-63S).</p> <p><u>REFERENCES (TM)</u> TM 9-2320-283-10.</p> <p><u>TROUBLESHOOTING REFERENCES</u> Paragraph 2-11.</p>	<p><u>EQUIPMENT CONDITION PARAGRAPH</u> TM 9-2320-283-10.</p> <p><u>SPECIAL ENVIRONMENTAL CONDITIONS</u> None.</p> <p><u>GENERAL SAFETY INSTRUCTIONS</u> Engine off. Transmission in neutral. Park brake set.</p>	<p><u>CONDITION DESCRIPTION</u> Air system draincocks open.</p>
---	---	---

**BRAKE SYSTEM.**

**3-173. TRAILER HAND BRAKE VALVE REPLACEMENT (Continued).**

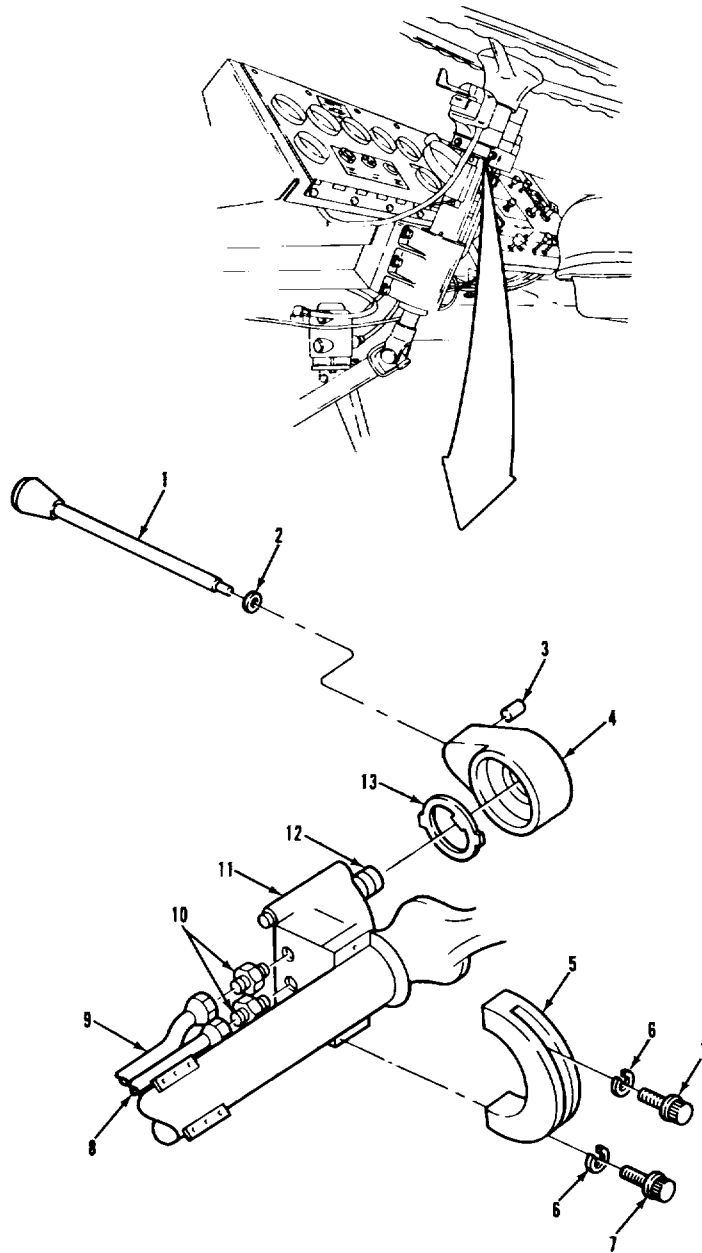

**LEGEND:**

- |                      |                              |
|----------------------|------------------------------|
| 1. LEVER             | 8. DELIVERY PORT AIR LINE    |
| 2. PREFORMED PACKING | 9. INLET VALVE AIR LINE      |
| 3. PIN               | 10. CONNECTOR (2)            |
| 4. HEAD              | 11. TRAILER HAND BRAKE VALVE |
| 5. RETAINING STRAP   | 12. ADJUSTING RING           |
| 6. LOCKWASHER (2)    | 13. LOCKING RING             |
| 7. BOLT (2)          |                              |

TA 237470

**BRAKE SYSTEM.**

**3-173. TRAILER HAND BRAKE VALVE REPLACEMENT (Continued).**

LOCATION/ITEM	ACTION	REMARKS
<p><b>WARNING</b></p> <p>Never work on air system components without first draining air pressure. Failure to follow this precaution can result in serious personal injury.</p>		
<p><b>A. REMOVAL.</b></p>		
1 Inlet valve air line (9) and delivery port air line (8).	Remove	Tag for identification.
2 Two bolts (7) and two lockwashers (6).	Loosen and remove.	
3 Retaining strap (5) and trailer hand brake valve (11).	Remove.	
4 Two connectors (10).	Loosen and remove.	
<p><b>B INSPECTION</b></p>		
5 Delivery port air line (8), valve and line (9), two connectors (10), and trailer hand brake valve (11).	Inspect for cracks, leaks, and damaged threads.	Replace as necessary.
<p><b>C INSTALLATION</b></p>		
6 Two connectors (10)	Install and tighten	Use thread sealing tape on threads.
7 Trailer hand brake valve (11) and retaining strap (5)	Position on opposite sides of steering column at convenient operating height.	
<p><b>3-1012</b></p>		

**BRAKE SYSTEM.**

**3-173. TRAILER HAND BRAKE VALVE REPLACEMENT (Continued).**

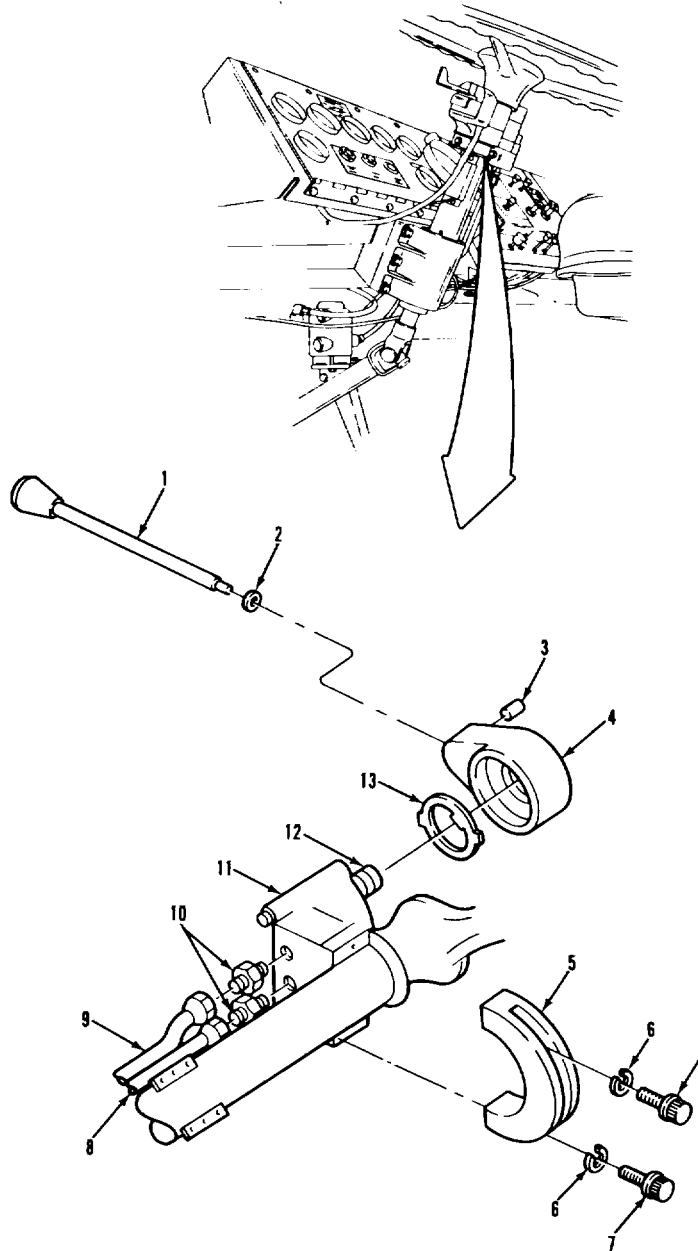

**LEGEND:**

- |                      |                              |
|----------------------|------------------------------|
| 1. LEVER             | 8. DELIVERY PORT AIR LINE    |
| 2. PREFORMED PACKING | 9. INLET VALVE AIR LINE      |
| 3. PIN               | 10. CONNECTOR (2)            |
| 4. HEAD              | 11. TRAILER HAND BRAKE VALVE |
| 5. RETAINING STRAP   | 12. ADJUSTING RING           |
| 6. LOCKWASHER (2)    | 13. LOCKING RING             |
| 7. BOLT (2)          |                              |

TA 237471

**BRAKE SYSTEM.**

**3-173. TRAILER HAND BRAKE VALVE REPLACEMENT (Continued).**

LOCATION/ITEM	ACTION	REMARKS
<b>C INSTALLATION (Continued)</b>		
8 Two bolts (7) and lockwashers (6)	Install through item (5) into item (11) and tighten.	
9 Inlet valve air line (9) and delivery port air line (8).	Connect and tighten identification from step 1.	Connect according to
<b>D OPERATIONAL CHECK</b>		
<b>NOTE</b>		
The trailer hand brake valve should deliver full reservoir pressure. Do the following procedure for testing and adjusting the hand brake valve.		
10 Air system draincocks	Close 283-10.	Refer to TM 9-2320-
11 Delivery port air line (8).	Disconnect from item (11).	
12 Air pressure gage	Connect to item (11)	Suitable gage, 0-200 psi.
13 Engine	Start up maximum reservoir pressure is reached.	Operate until Refer to TM 9-2320-283-10.
14 Lever (1)	Operate.	
15 Air pressure gage	Should indicate between 90 and 120 psi	To adjust, do subparagraph E.
16 Engine	Shut down	Refer to TM 9-2320-283-10.
<b>3-1014</b>		

**BRAKE SYSTEM.**

**3-173. TRAILER HAND BRAKE VALVE REPLACEMENT (Continued).**

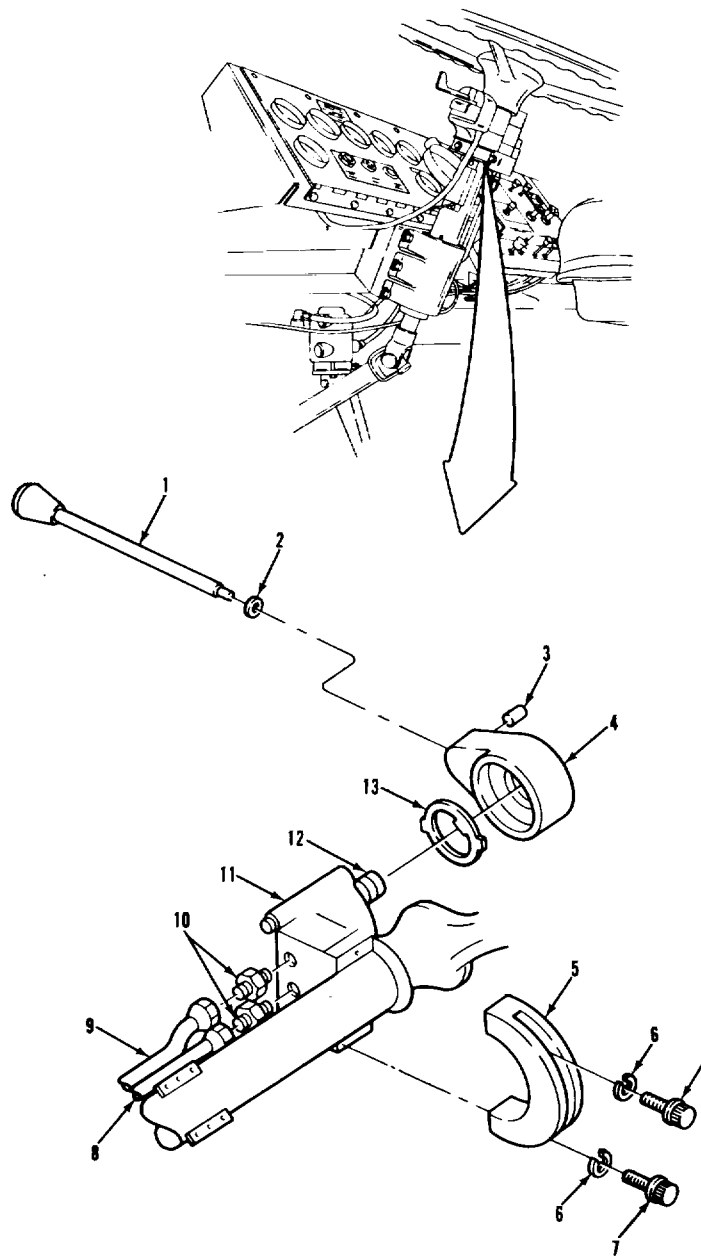

**LEGEND:**

- |                      |                              |
|----------------------|------------------------------|
| 1. LEVER             | 8. DELIVERY PORT AIR LINE    |
| 2. PREFORMED PACKING | 9. INLET VALVE AIR LINE      |
| 3. PIN               | 10. CONNECTOR (2)            |
| 4. HEAD              | 11. TRAILER HAND BRAKE VALVE |
| 5. RETAINING STRAP   | 12. ADJUSTING RING           |
| 6. LOCKWASHER (2)    | 13. LOCKING RING             |
| 7. BOLT (2)          |                              |

TA 237472

**BRAKE SYSTEM.**

**3-173. TRAILER HAND BRAKE VALVE REPLACEMENT (Continued).**

LOCATION/ITEM	ACTION	REMARKS
<b>NOTE</b> Delivered pressure can be raised or lowered by rotating adjusting ring.		
E. ADJUSTMENT. I		
<b>WARNING</b> Never work on air system components without first draining air pressure. Failure to follow this precaution can result in serious personal injury.		
17 Air system draincocks	Open	Refer to TM 9-2320-283-10.
18 Pin (3)	Remove	Use hammer and pin punch.
19 Lever (1) with preformed packing (2).	Remove from item (4).	
20 Head (4)	Remove.	
21 Locking ring (13)	Remove.	
22 Adjusting ring (12)	a Lower delivered pressure by turning item (12) counterclockwise.	Use small screwdriver inserted in one of the inner notches of item (12) Turning item (12) one notch will adjust the delivered pressure approximately 5 psi.
	b Raise delivered pressure by turning item (12) clockwise.	
<b>3-1016</b>		



**BRAKE SYSTEM.**

**3-173. TRAILER HAND BRAKE VALVE REPLACEMENT (Continued).**

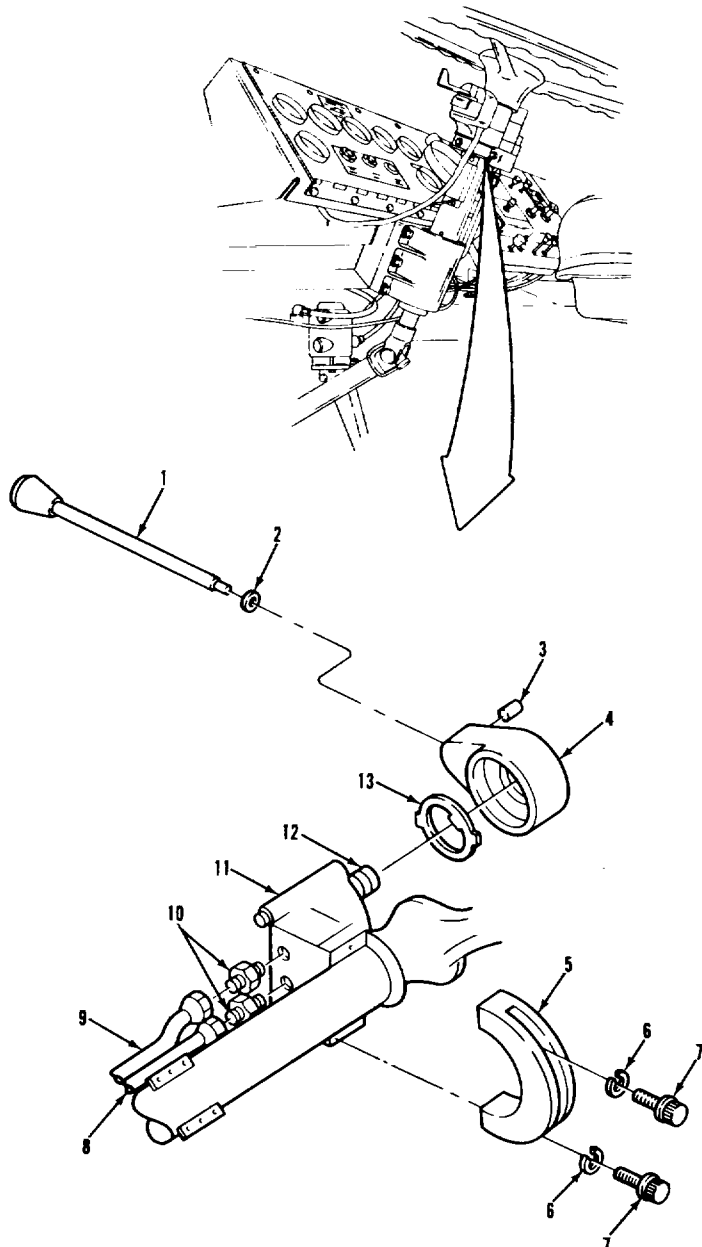

**LEGEND:**

- |                      |                              |
|----------------------|------------------------------|
| 1. LEVER             | 8. DELIVERY PORT AIR LINE    |
| 2. PREFORMED PACKING | 9. INLET VALVE AIR LINE      |
| 3. PIN               | 10. CONNECTOR (2)            |
| 4. HEAD              | 11. TRAILER HAND BRAKE VALVE |
| 5. RETAINING STRAP   | 12. ADJUSTING RING           |
| 6. LOCKWASHER (2)    | 13. LOCKING RING             |
| 7. BOLT (2)          |                              |

TA 237473

**BRAKE SYSTEM.**

**3-173. TRAILER HAND BRAKE VALVE REPLACEMENT (Continued).**

LOCATION/ITEM	ACTION	REMARKS
<b>E. ADJUSTMENT (Continued).</b>		
23 Locking ring (13)	Install.	
24 Head (4)	Install.	
25 Lever (1) with preformed packing (2).	Install into item (4)	End of item (1) fits into hole in item (12).
26 Pin (3)	Install through item (4) into item (12)	Use pin punch and hammer.
27 Air pressure gage	Remove from item (11).	
28 Delivery port air line (8).	Connect and tighten.	

**NOTE**

Follow-on maintenance action required: Close air system draincocks and start engine (TM 9-2320-283-10). Check air system for leaks (para 3-8).

**3-1018**

**BRAKE SYSTEM.**

**3-173. TRAILER HAND BRAKE VALVE REPLACEMENT (Continued).**

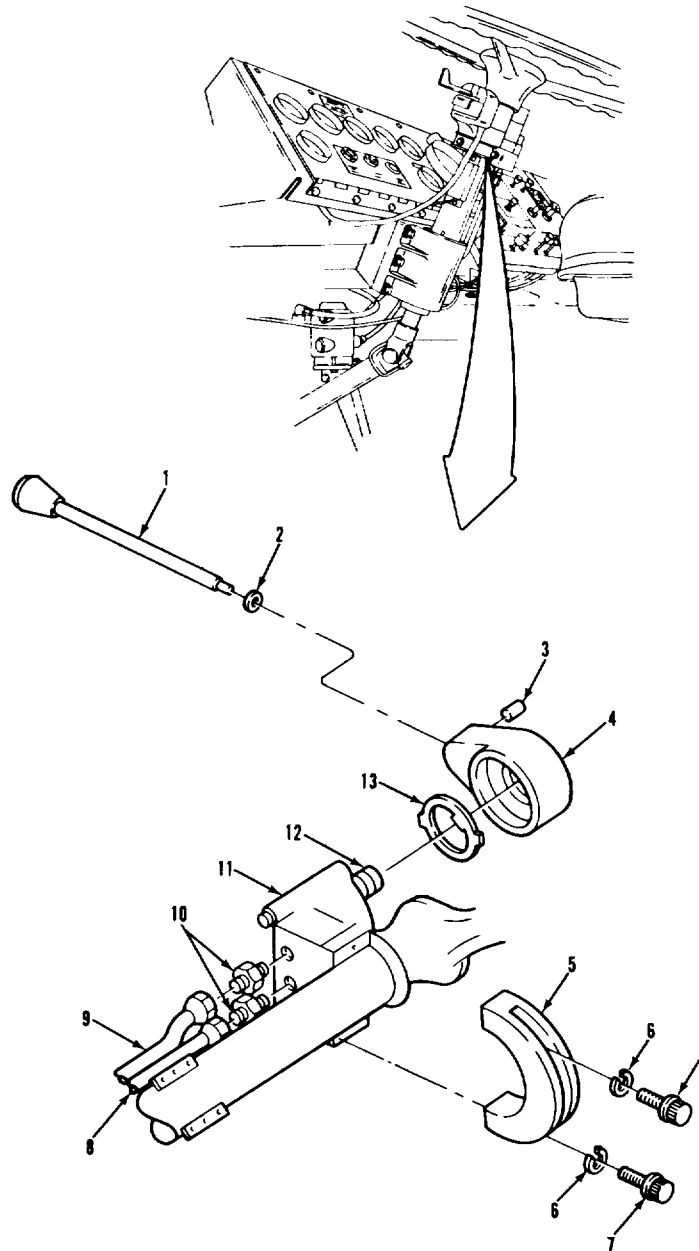

**LEGEND:**

- |                      |                              |
|----------------------|------------------------------|
| 1. LEVER             | 8. DELIVERY PORT AIR LINE    |
| 2. PREFORMED PACKING | 9. INLET VALVE AIR LINE      |
| 3. PIN               | 10. CONNECTOR (2)            |
| 4. HEAD              | 11. TRAILER HAND BRAKE VALVE |
| 5. RETAINING STRAP   | 12. ADJUSTING RING           |
| 6. LOCKWASHER (2)    | 13. LOCKING RING             |
| 7. BOLT (2)          |                              |

TA 237474

TA

**BRAKE SYSTEM.****3-174. BRAKE TREADLE VALVE REPLACEMENT.****THIS TASK COVERS**

- a. Removal.
- b. Cleaning and Inspection.
- c. Installation.

**INITIAL SETUP**

<u>APPLICABLE CONFIGURATIONS</u>	<u>EQUIPMENT CONDITION PARAGRAPH</u>	<u>CONDITION DESCRIPTION</u>
All.	TM 9-2320-283-10.	Air system draincocks opened.
<u>TEST EQUIPMENT</u> None.	3-184.	Firewall double check valve removed from brake treadle valve.
<u>SPECIAL TOOLS</u> None.	3-193.	Brake pedal double check valve removed from brake valve.
<u>MATERIALS/PARTS (P/N)</u> Tape, thread sealing Item 32, Appendix C. Solution, soap Item 28, Appendix C. Pin, cotter (06853) 200981. Pin, cotter (06853) 210492.		
<u>PERSONNEL REQUIRED</u> One (MOS-63S).	<u>SPECIAL ENVIRONMENTAL CONDITIONS</u> None.	
<u>REFERENCES (TM)</u> TM 9-2320-283-10.	<u>GENERAL SAFETY INSTRUCTIONS</u> Engine off. Transmission in neutral. Park brake set.	
<u>TROUBLESHOOTING REFERENCES</u> Paragraph 2-11.		

**BRAKE SYSTEM.**

**3-174. BRAKE TREADLE VALVE REPLACEMENT (Continued).**

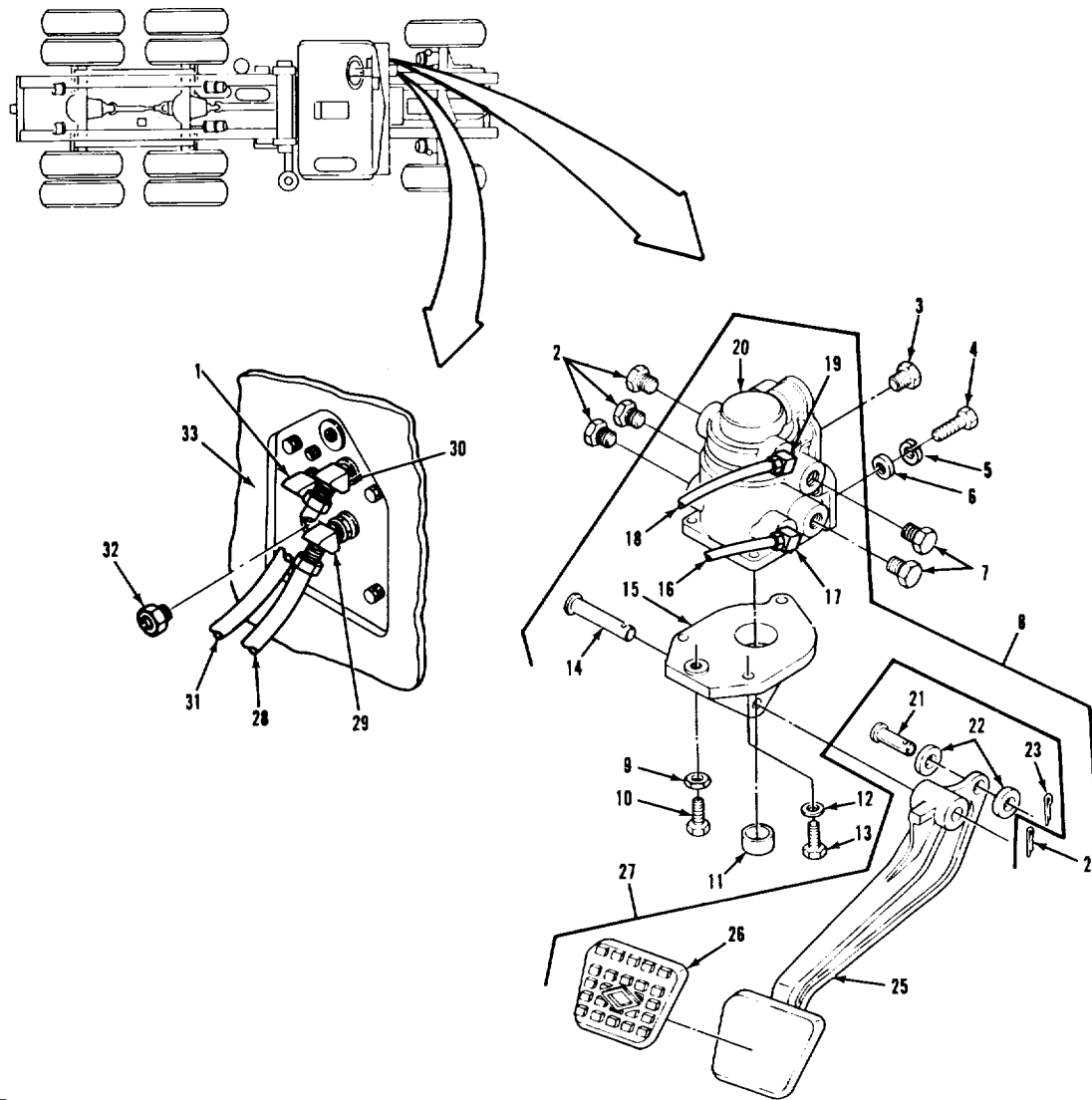

**LEGEND:**

- |                         |                      |                      |
|-------------------------|----------------------|----------------------|
| 1. ELBOW                | 12. LOCKWASHER (3)   | 23. COTTER PIN       |
| 2. PLUG (3)             | 13. SCREW (3)        | 24. COTTER PIN       |
| 3. PLUG                 | 14. FULCRUM PIN      | 25. PEDAL            |
| 4. SCREW (3)            | 15. MOUNTING PLATE   | 26. PEDAL COVER      |
| 5. LOCKWASHER (3)       | 16. NONMETALLIC TUBE | 27. PEDAL ASSEMBLY   |
| 6. PLAIN WASHER (3)     | 17. ELBOW            | 28. NONMETALLIC TUBE |
| 7. PLUG (2)             | 18. NONMETALLIC TUBE | 29. MALE ELBOW       |
| 8. BRAKE VALVE ASSEMBLY | 19. ELBOW            | 30. MALE ELBOW       |
| 9. HEXAGON HEAD NUT     | 20. BRAKE VALVE      | 31. NONMETALLIC TUBE |
| 10. STOP BUTTON         | 21. ROLLER PIN       | 32. REDUCER          |
| 11. PLUNGER             | 22. ROLLER (2)       | 33. FIREWALL         |

TA 237475

**BRAKE SYSTEM.****3-174. BRAKE TREADLE VALVE REPLACEMENT (Continued).**

LOCATION/ITEM	ACTION	REMARKS
<p><b>WARNING</b></p> <p>Never work on air system components without first draining air pressure. Failure to follow this precaution can result in serious personal injury.</p>		
<b>A. REMOVAL.</b>		
1 Cotter pin (24)	Remove from item (14)	Discard item (24).
2 Roller pin (14)	Remove from items (15) and (25).	
3 Pedal (25)	Remove from item (15).	
4 Plunger (11)	Remove from item (15)	Item (11) will drop out of item (20) when item (25) is removed.
5 Pedal cover (26)	Remove from item (25).	
6 Cotter pin (23)	Remove from item (21)	Discard item (23).
7 Roller pin (21)	Push out of item (25)	Two items (22) will fall out when item (21) is removed.
8 Two tubes (16) and (18)	Remove from items (17) and (19)	Tag items (16) and (18) for identification.
9 Two elbows (17) and (19)	Remove from item (20)	Scribe a line to mark the position of items (17) and (19) for use during installation.
10 Two plugs (7) and plug (3).	Remove from item (20).	
11 Three plugs (2)	Remove from item (20).	
12 Two tubes (28) and (31)	Remove from items (29) and (30)	Tag items (28) and (31) for identification.
13 Elbows (1), (29), and (30)	Remove from item (20)	Scribe a line to mark the approximate position of items (1), (29), and (30) for correct positioning during installation.

**BRAKE SYSTEM.**

**3-174. BRAKE TREADLE VALVE REPLACEMENT (Continued).**

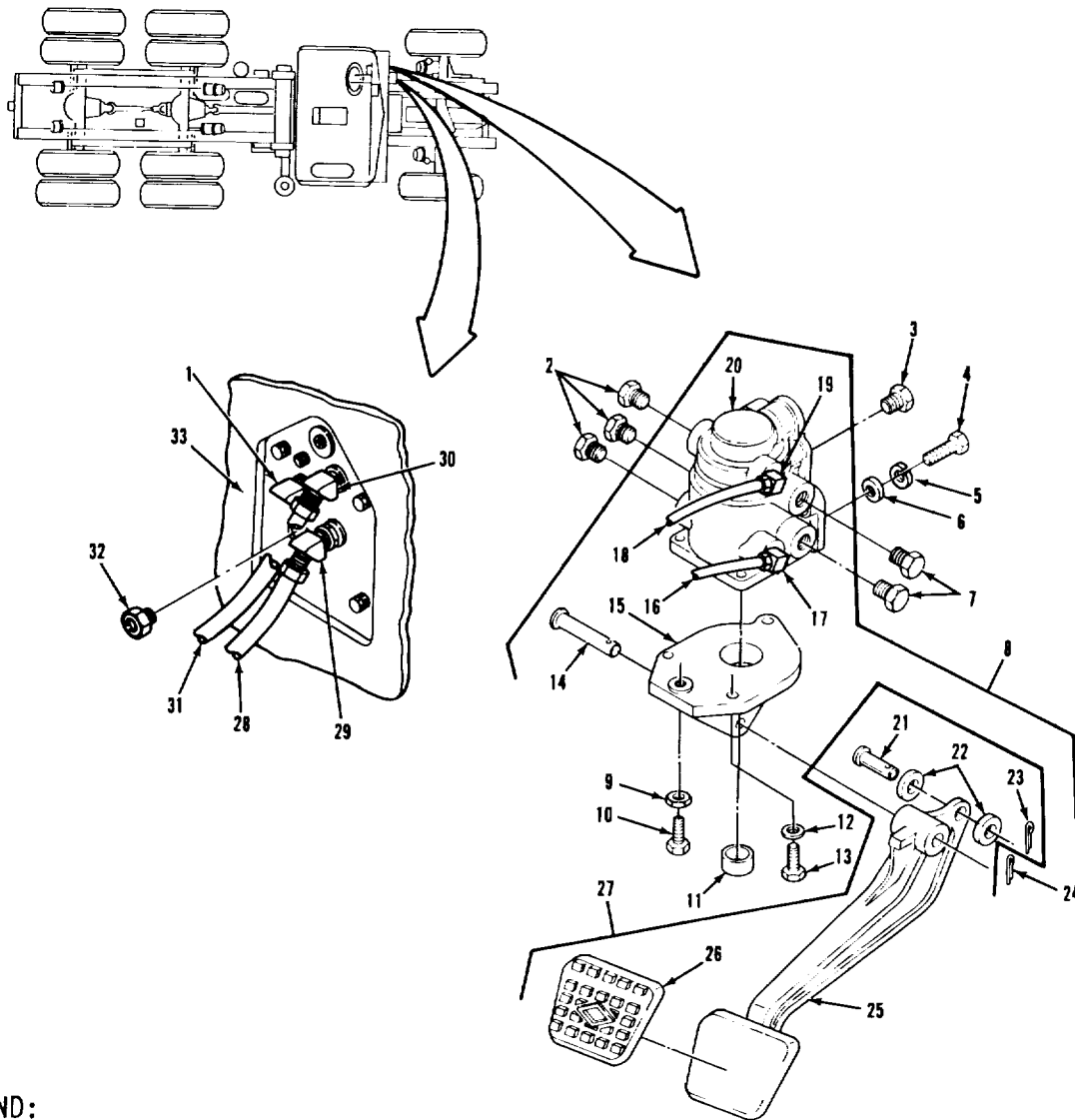

**LEGEND:**

- |                         |                      |                      |
|-------------------------|----------------------|----------------------|
| 1. ELBOW                | 12. LOCKWASHER (3)   | 23. COTTER PIN       |
| 2. PLUG (3)             | 13. SCREW (3)        | 24. COTTER PIN       |
| 3. PLUG                 | 14. FULCRUM PIN      | 25. PEDAL            |
| 4. SCREW (3)            | 15. MOUNTING PLATE   | 26. PEDAL COVER      |
| 5. LOCKWASHER (3)       | 16. NONMETALLIC TUBE | 27. PEDAL ASSEMBLY   |
| 6. PLAIN WASHER (3)     | 17. ELBOW            | 28. NONMETALLIC TUBE |
| 7. PLUG (2)             | 18. NONMETALLIC TUBE | 29. MALE ELBOW       |
| 8. BRAKE VALVE ASSEMBLY | 19. ELBOW            | 30. MALE ELBOW       |
| 9. HEXAGON HEAD NUT     | 20. BRAKE VALVE      | 31. NONMETALLIC TUBE |
| 10. STOP BUTTON         | 21. ROLLER PIN       | 32. REDUCER          |
| 11. PLUNGER             | 22. ROLLER (2)       | 33. FIREWALL         |

TA 237476

**BRAKE SYSTEM.**

**3-174. BRAKE TREADLE VALVE REPLACEMENT (Continued).**

LOCATION/ITEM	ACTION	REMARKS
<b>A REMOVAL (Continued)</b>		
14 Reducer (32) 15 Three screws (4), lockwashers (5), and washers (6)	Remove from item (20). Remove from item (20)	Item (20) will drop when the last item (4) is removed.
16 Brake valve (20) 17 Brake valve (20)	Remove from item (33). Secure in bench vise.	
18 Three screws (13) and lockwashers (12).	Remove from item (15).	
19 Plate (15)	Remove from item (20).	
20 Stop button (10) and nut (9).	Remove from item (15).	
21 Nut (9)	Remove from item (10)	Before removing the hexagon head nut, mea- sure the distance be- tween the top of item (10) and item (9). This measurement should be used for locating proper distance during instal- lation.
22 Brake valve (20)	Remove from bench vise.	
<b>B CLEANING AND INSPECTION I</b>		
23 All metal parts	Clean and inspect	Refer to paragraphs 3-4 and 3-5.
<b>C INSTALLATION</b>		
24 Brake valve (20)	Secure in bench vise, bottom side up.	
25 Plate (15)	Line up holes in item (15) with holes in item (20).	
<b>3-1024</b>		



**BRAKE SYSTEM.**

**3-174. BRAKE TREADLE VALVE REPLACEMENT (Continued).**

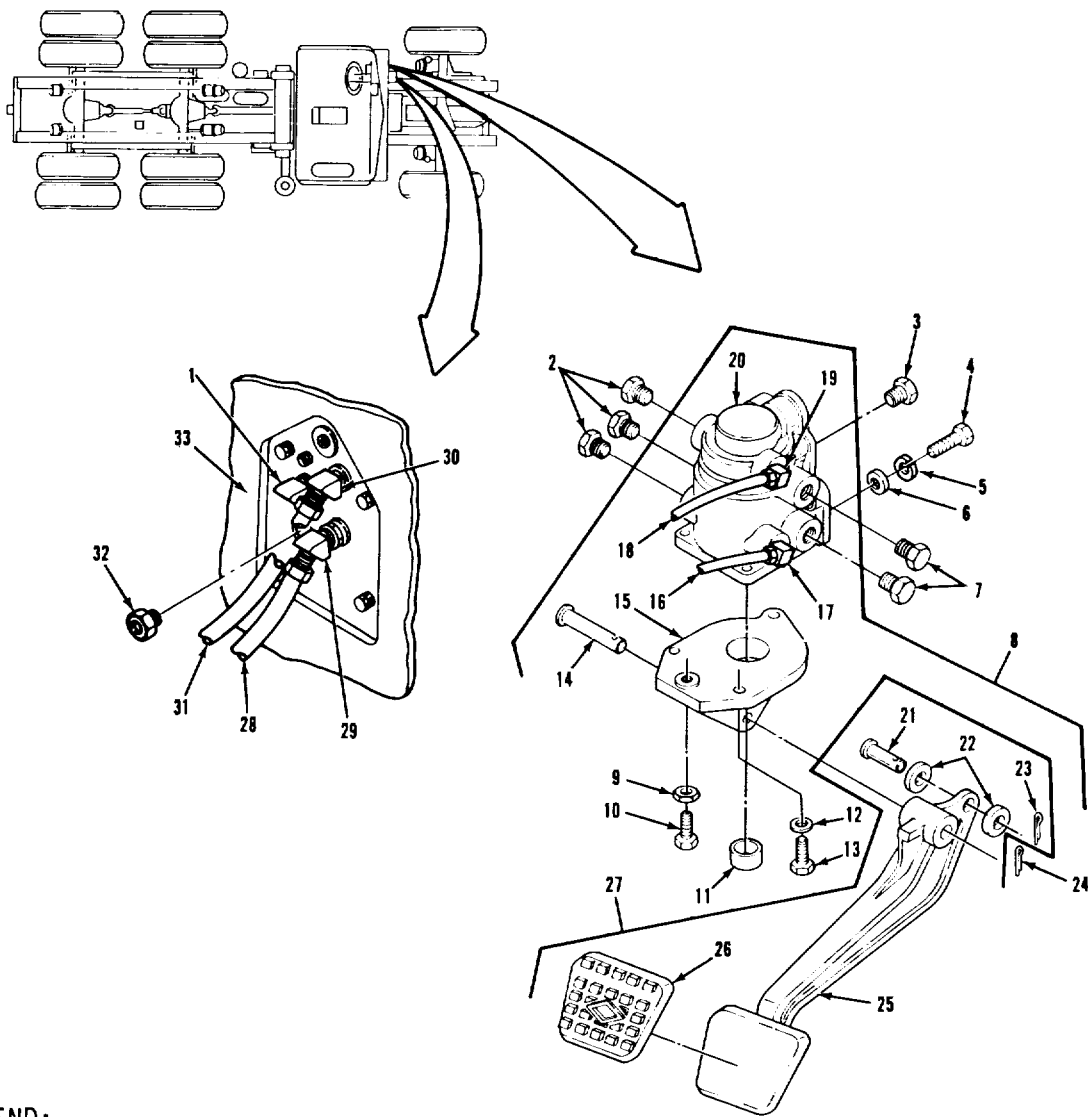

**LEGEND:**

- |                         |                      |                      |
|-------------------------|----------------------|----------------------|
| 1. ELBOW                | 12. LOCKWASHER (3)   | 23. COTTER PIN       |
| 2. PLUG (3)             | 13. SCREW (3)        | 24. COTTER PIN       |
| 3. PLUG                 | 14. FULCRUM PIN      | 25. PEDAL            |
| 4. SCREW (3)            | 15. MOUNTING PLATE   | 26. PEDAL COVER      |
| 5. LOCKWASHER (3)       | 16. NONMETALLIC TUBE | 27. PEDAL ASSEMBLY   |
| 6. PLAIN WASHER (3)     | 17. ELBOW            | 28. NONMETALLIC TUBE |
| 7. PLUG (2)             | 18. NONMETALLIC TUBE | 29. MALE ELBOW       |
| 8. BRAKE VALVE ASSEMBLY | 19. ELBOW            | 30. MALE ELBOW       |
| 9. HEXAGON HEAD NUT     | 20. BRAKE VALVE      | 31. NONMETALLIC TUBE |
| 10. STOP BUTTON         | 21. ROLLER PIN       | 32. REDUCER          |
| 11. PLUNGER             | 22. ROLLER (2)       | 33. FIREWALL         |

TA 237477

**BRAKE SYSTEM.**

**3-174. BRAKE TREADLE VALVE REPLACEMENT (Continued).**

LOCATION/ITEM	ACTION	REMARKS
<b>C. INSTALLATION (Continued)</b>		
26 Three screws (13) and lockwashers (12).	Install in item (15) and tighten.	
27 Nut (9)	Install onto item (10)	Item (9) should be installed to the height measured in step 21 during disassembly.
28 Stop button (10) and nut (9)	Install into item (15) until item (9) seats against item (15). Tighten item (9) against item (15).	
29 Brake valve (20)	Line up holes in item (20) with item (33)	An assistant will be required to hold item (20) onto item (33).
30 Three screws (4), lockwashers (5), and washers (6).	Install into item (20) and tighten.	
<b>NOTE</b>		
Wrap all pipe threads with thread sealing tape prior to installation.		
31 Reducer (32) and three elbows (1), (29), and (30)	Install in item (20)	Install items (1), (29), and (30) according to the alining marks made during disassembly.
32 Tube (28)	Install onto item (29).	
33 Tube (31)	Install onto item (30).	
34 Plug (3)	Install in item (20).	
35 Two plugs (7)	Install in item (20) on right-hand side.	
36 Three plugs (2)	Install in item (20) on left-hand side	

**BRAKE SYSTEM.**

**3-174. BRAKE TREADLE VALVE REPLACEMENT (Continued).**

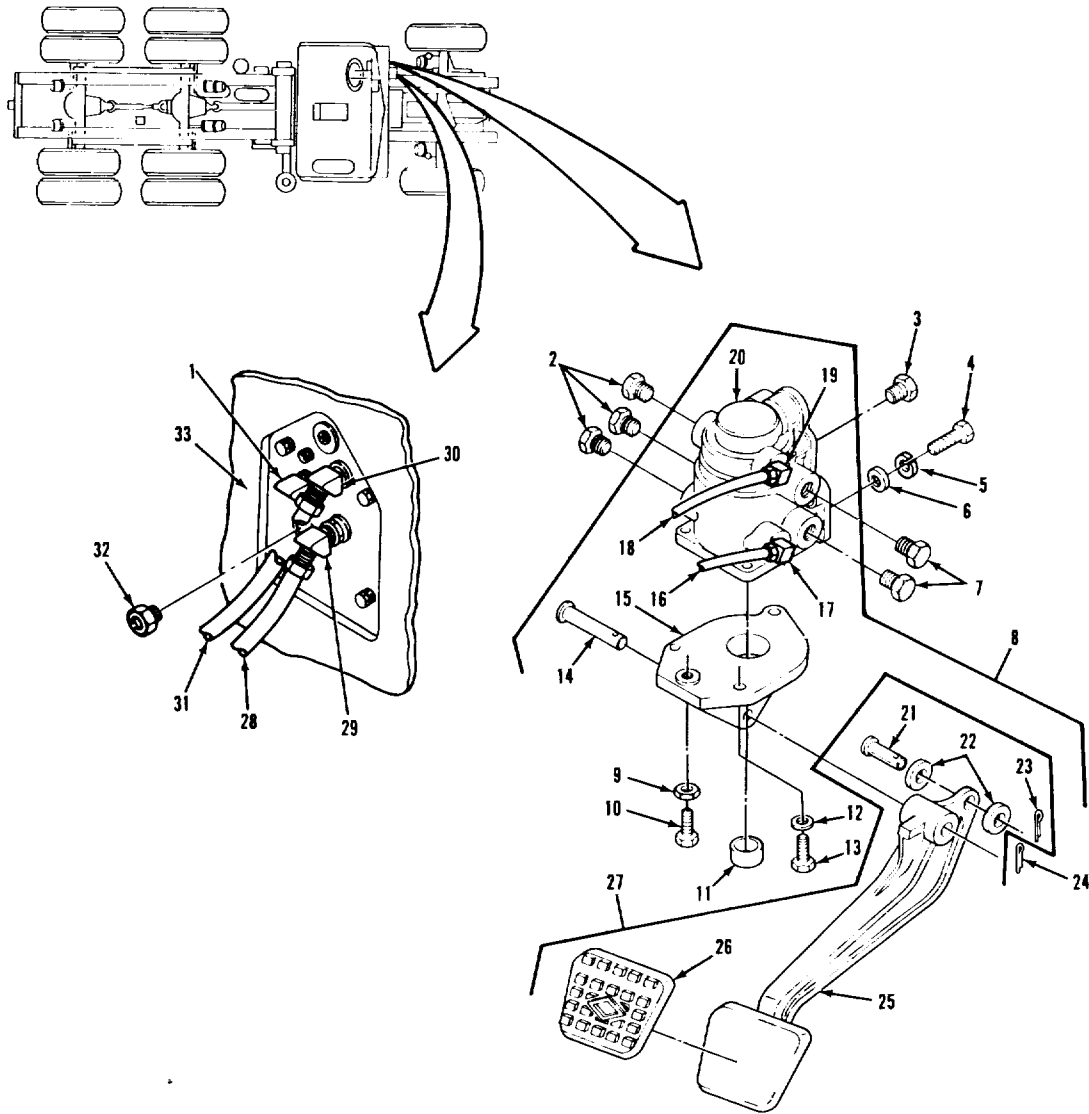

**LEGEND:**

- |                         |                      |                      |
|-------------------------|----------------------|----------------------|
| 1. ELBOW                | 12. LOCKWASHER (3)   | 23. COTTER PIN       |
| 2. PLUG (3)             | 13. SCREW (3)        | 24. COTTER PIN       |
| 3. PLUG                 | 14. FULCRUM PIN      | 25. PEDAL            |
| 4. SCREW (3)            | 15. MOUNTING PLATE   | 26. PEDAL COVER      |
| 5. LOCKWASHER (3)       | 16. NONMETALLIC TUBE | 27. PEDAL ASSEMBLY   |
| 6. PLAIN WASHER (3)     | 17. ELBOW            | 28. NONMETALLIC TUBE |
| 7. PLUG (2)             | 18. NONMETALLIC TUBE | 29. MALE ELBOW       |
| 8. BRAKE VALVE ASSEMBLY | 19. ELBOW            | 30. MALE ELBOW       |
| 9. HEXAGON HEAD NUT     | 20. BRAKE VALVE      | 31. NONMETALLIC TUBE |
| 10. STOP BUTTON         | 21. ROLLER PIN       | 32. REDUCER          |
| 11. PLUNGER             | 22. ROLLER (2)       | 33. FIREWALL         |

TA 237478

**BRAKE SYSTEM.**

**3-174. BRAKE TREADLE VALVE REPLACEMENT (Continued).**

LOCATION/ITEM	ACTION	REMARKS
<b>C INSTALLATION (Continued) J</b>		
37 Tube (18)	Install onto item (19).	
38 Tube (16)	Install onto item (17).	
39 Roller (22)	Install one only onto item (21).	
40 Roller pin assembly (21) and roller (22).	Install in hole of item (25).	
41 Remaining roller (22).	Install onto item (21).	
42 New cotter pin (23)	Install in hole of item (21). Bend ends of item (23).	
43 Pedal cover (26)	Install onto item (25).	
44 Plunger (11)	Install in hole of item (15)	Item (11) may slide out of hole.
45 Pedal assembly (27)	Line up holes of item (27) to holes of bottom side of item (20)	Make certain item (11) has not fallen out of item (15).
46 Fulcrum pin (14)	Install through holes of item (15) and (27).	
47 New cotter pin (24)	Install in hole of item (14). Bend ends of item (24).	

**NOTE**

Follow-on maintenance action required:

- Install firewall double check valve (para 3-184).
- Install brake pedal double check valve (para 3-193).
- Close air system draincocks and start engine (TM 9-2320-283-10).
- Check air system for leaks (para 3-8).

**3-1028**

**BRAKE SYSTEM.**

**3-174. BRAKE TREADLE VALVE REPLACEMENT (Continued).**

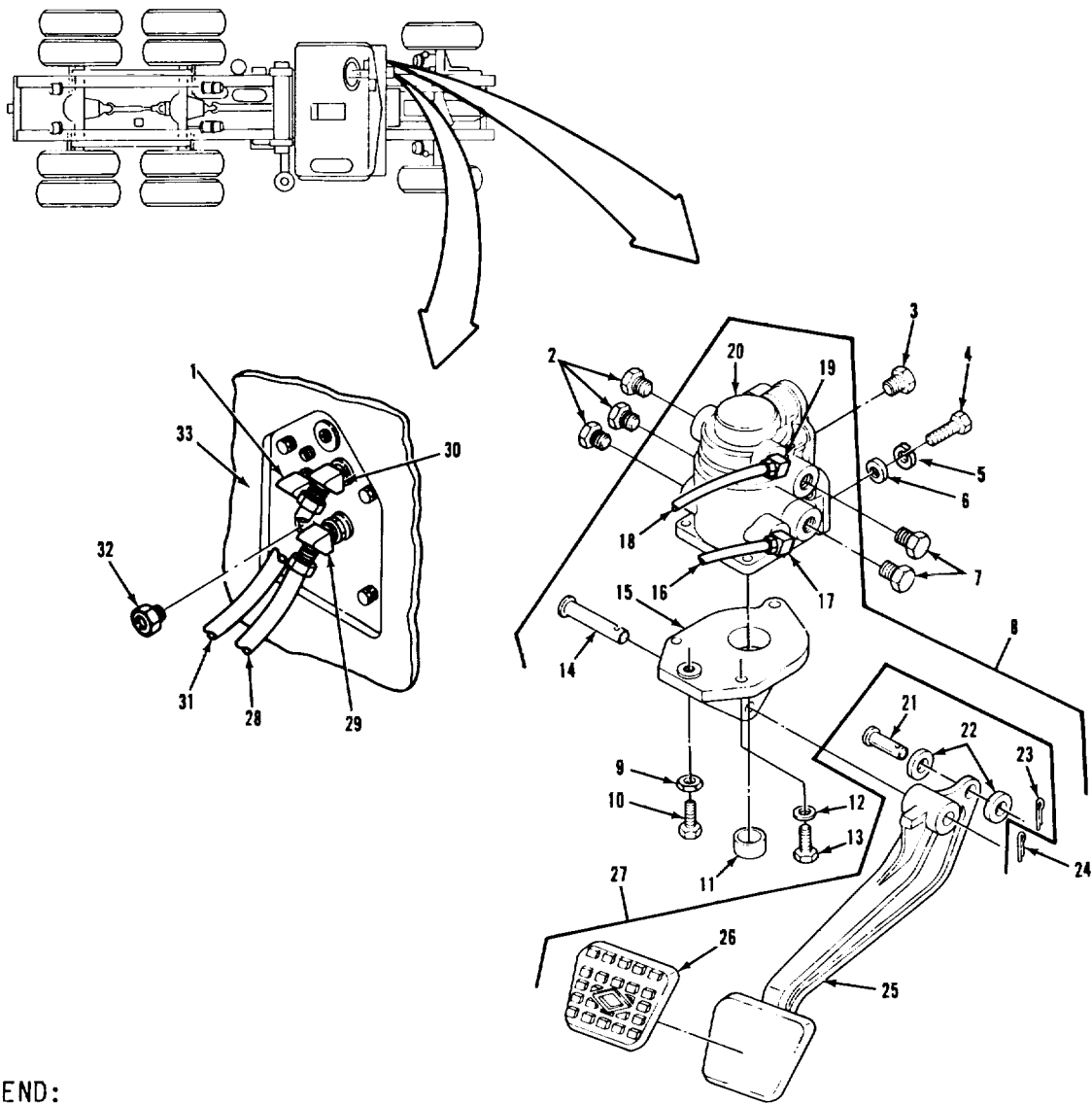

**LEGEND:**

- |                         |                      |                      |
|-------------------------|----------------------|----------------------|
| 1. ELBOW                | 12. LOCKWASHER (3)   | 23. COTTER PIN       |
| 2. PLUG (3)             | 13. SCREW (3)        | 24. COTTER PIN       |
| 3. PLUG                 | 14. FULCRUM PIN      | 25. PEDAL            |
| 4. SCREW (3)            | 15. MOUNTING PLATE   | 26. PEDAL COVER      |
| 5. LOCKWASHER (3)       | 16. NONMETALLIC TUBE | 27. PEDAL ASSEMBLY   |
| 6. PLAIN WASHER (3)     | 17. ELBOW            | 28. NONMETALLIC TUBE |
| 7. PLUG (2)             | 18. NONMETALLIC TUBE | 29. MALE ELBOW       |
| 8. BRAKE VALVE ASSEMBLY | 19. ELBOW            | 30. MALE ELBOW       |
| 9. HEXAGON HEAD NUT     | 20. BRAKE VALVE      | 31. NONMETALLIC TUBE |
| 10. STOP BUTTON         | 21. ROLLER PIN       | 32. REDUCER          |
| 11. PLUNGER             | 22. ROLLER (2)       | 33. FIREWALL         |

TA 237479

**BRAKE SYSTEM.**

**3-175. TRAILER SUPPLY VALVE REPLACEMENT.**

**THIS TASK COVERS**

- a. Removal.
- b. Cleaning and Inspection.
- c. Installation.

**INITIAL SETUP**

**APPLICABLE CONFIGURATIONS**

All.  
opened.

**TEST EQUIPMENT**

None.

**SPECIAL TOOLS**

None.

**MATERIALS/PARTS IP/N)**

Tape, thread sealing  
Item 32, Appendix C.

**PERSONNEL REQUIRED**

One (MOS-63S).

**REFERENCES (TM)**

TM 9-2320-283-10.

**TROUBLESHOOTING REFERENCES**

Paragraph 2-11.

**EQUIPMENT CONDITION**

**PARAGRAPH**

TM 9-2320-283-10.

3-120.

**CONDITION DESCRIPTION**

Air system draincocks

Battery power  
disconnected.

**SPECIAL ENVIRONMENTAL CONDITIONS**

None.

**GENERAL SAFETY INSTRUCTIONS**

Engine off.  
Transmission in neutral.  
Park brake set.

**BRAKE SYSTEM.**

**3-175. TRAILER SUPPLY VALVE REPLACEMENT (Continued).**

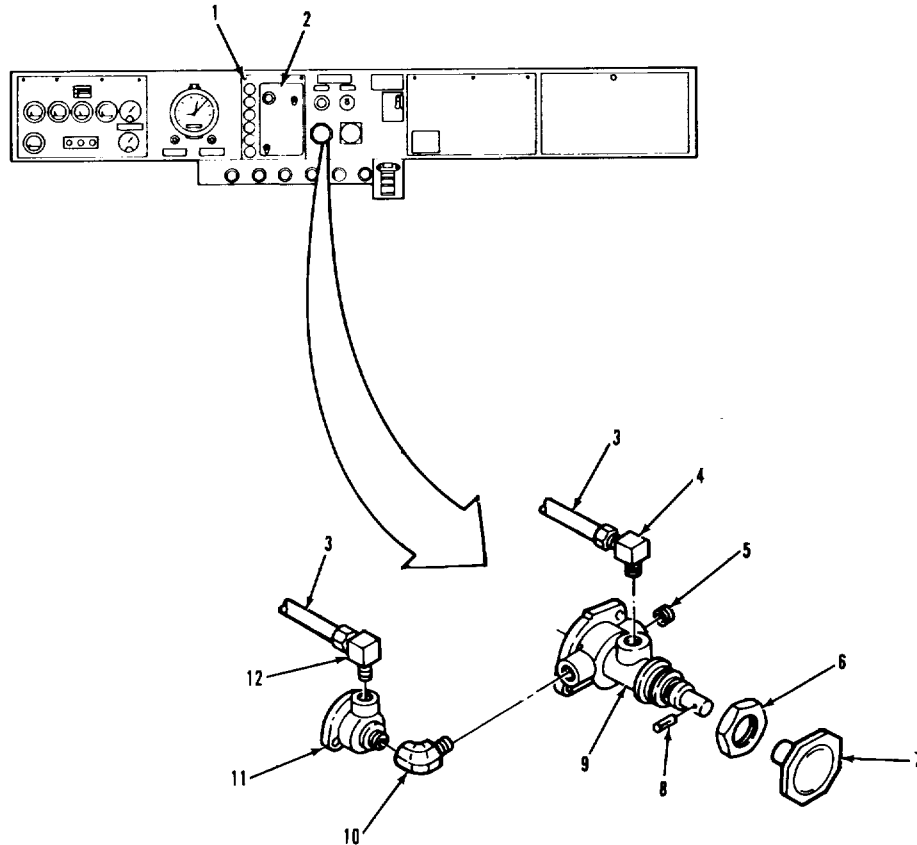

**LEGEND:**

- |                           |                                    |
|---------------------------|------------------------------------|
| 1. QUARTER-TURN SCREW (2) | 7. KNOB                            |
| 2. INSTRUMENT PANEL       | 8. PIN                             |
| 3. AIR LINE (2)           | 9. TRAILER SUPPLY VALVE ASSEMBLY   |
| 4. 90° MALE ELBOW         | 10. ELBOW                          |
| 5. PLUG                   | 11. TRACTOR PROTECTION PILOT VALVE |
| 6. NUT                    | 12. ELBOW                          |

TA 237480

**BRAKE SYSTEM.**

**3-175. TRAILER SUPPLY VALVE REPLACEMENT (Continued).**

LOCATION/ITEM	ACTION	REMARKS
---------------	--------	---------

**WARNING**

Never work on air system components without first draining air pressure. Failure to follow this precaution can result in serious personal injury.

**A. REMOVAL.**

1 Two quarter-turn screws (1).	Loosen.	
2 Instrument panel (2).	Lower.	
3 Two air lines (3)	Remove	Tag.
4 Pin (8)	Remove from items (7) and (9).	Use small drift punch.
5 Knob (7)	Remove	Pull off.
6 Nut (6)	Loosen and remove.	
7 Trailer supply valve assembly (9).	Remove.	
8 90° male elbow (4), elbow (12), tractor protection pilot valve (11), elbow (10), and plug (5).	Remove.	

**B. CLEANING AND INSPECTION.**

9 All parts	Clean and inspect	Refer to paragraphs 3-4 and 3-5.
-------------	-------------------	----------------------------------

**3-1032**



**BRAKE SYSTEM.**

**3-175. TRAILER SUPPLY VALVE REPLACEMENT (Continued).**

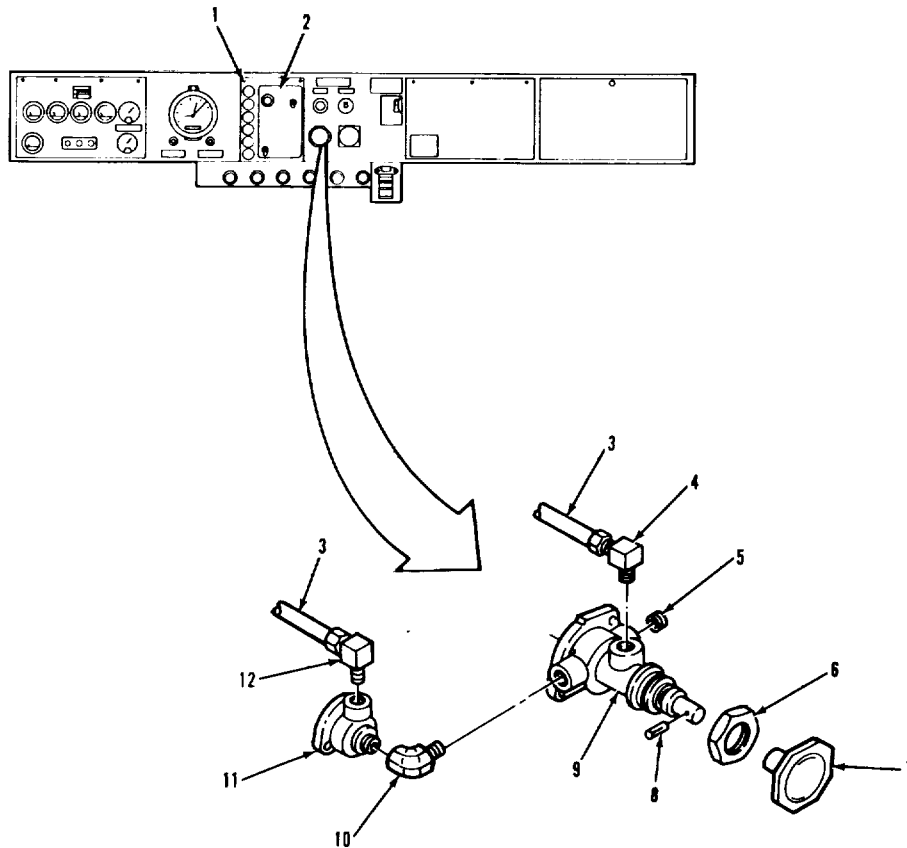

**LEGEND:**

- |                           |                                    |
|---------------------------|------------------------------------|
| 1. QUARTER-TURN SCREW (2) | 7. KNOB                            |
| 2. INSTRUMENT PANEL       | 8. PIN                             |
| 3. AIR LINE (2)           | 9. TRAILER SUPPLY VALVE ASSEMBLY   |
| 4. 90° MALE ELBOW         | 10. ELBOW                          |
| 5. PLUG                   | 11. TRACTOR PROTECTION PILOT VALVE |
| 6. NUT                    | 12. ELBOW                          |

TA 237481

**BRAKE SYSTEM.**

3-175. TRAILER SUPPLY VALVE REPLACEMENT (Continued).		
LOCATION/ITEM	ACTION	REMARKS
<u>C INSTALLATION.</u>		
10 Plug (5), elbow (10), tractor protection pilot valve (11), elbow (12), and 90° male elbow (4).	Install	Use thread sealing tape on threads.
11 Trailer supply valve assembly (9).	Aline with mounting hole and install.	
12 Nut (6)	Install and tighten.	
13 Knob (7)	Install on shaft of item (9) and secure with item (8) driven through pinhole.	Use small drift punch.
14 Two air lines (3)	Install and tighten.	
<p><b>NOTE</b>  <b>Follow-on maintenance action required:</b>   <b>Connect battery power (para 3-120).</b>  <b>Close air system draincocks and start engine (TM 9-2320-283-10).</b>  <b>Check air system for leaks (para 3-8).</b></p>		

**BRAKE SYSTEM.**

**3-175. TRAILER SUPPLY VALVE REPLACEMENT (Continued).**

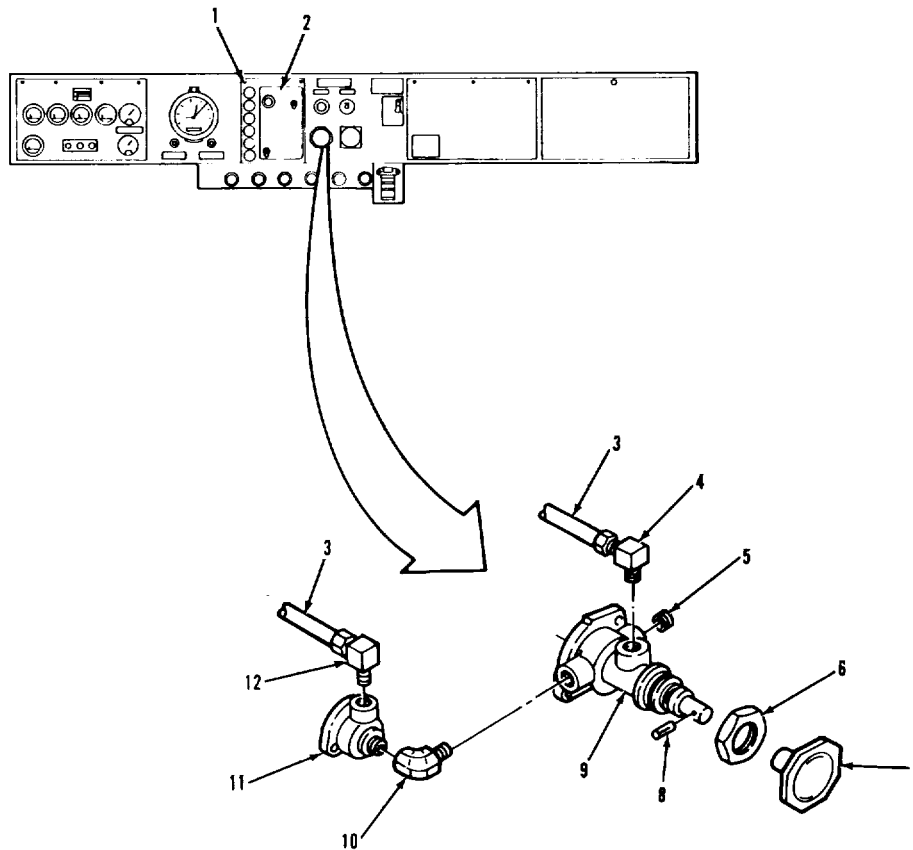

**LEGEND:**

- |                           |                                    |
|---------------------------|------------------------------------|
| 1. QUARTER-TURN SCREW (2) | 7. KNOB                            |
| 2. INSTRUMENT PANEL       | 8. PIN                             |
| 3. AIR LINE (2)           | 9. TRAILER SUPPLY VALVE ASSEMBLY   |
| 4. 90° MALE ELBOW         | 10. ELBOW                          |
| 5. PLUG                   | 11. TRACTOR PROTECTION PILOT VALVE |
| 6. NUT                    | 12. ELBOW                          |

TA 237482

**BRAKE SYSTEM.**

**3-176. TRAILER SUPPLY VALVE REPAIR.**

**THIS TASK COVERS**

- a. Disassembly.
- b. Cleaning and Inspection.
- c. Reassembly.

INITIAL SETUP

APPLICABLE CONFIGURATIONS

All.

EQUIPMENT CONDITION

PARAGRAPH

3-175.

CONDITION DESCRIPTION

Trailer supply valve removed.

TEST EQUIPMENT

None.

SPECIAL TOOLS

None.

MATERIALS/PARTS (P/N)

Grease, silicone, lubrication  
Item 9, Appendix C.  
Compound, thread locking  
Item 10, Appendix C.  
Kit, seal  
(78330) 1069.

PERSONNEL REQUIRED

One (MOS-63S).

SPECIAL ENVIRONMENTAL CONDITIONS

None.

REFERENCES (TM)

TM 9-2320-283-20P.

GENERAL SAFETY INSTRUCTIONS

Wear eye protection.

TROUBLESHOOTING REFERENCES

Paragraph 2-11.

**BRAKE SYSTEM.**  
**3-176. TRAILER SUPPLY VALVE REPAIR (Continued).**

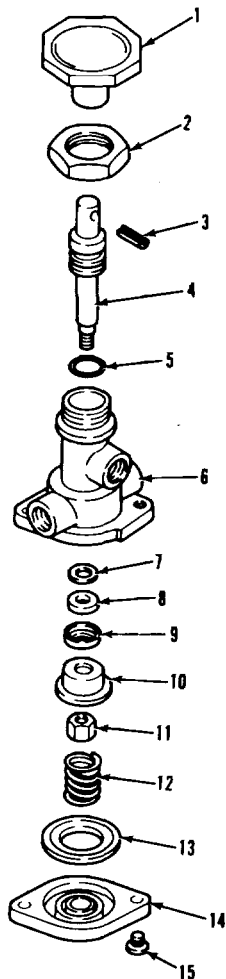

**LEGEND:**

- |                |                  |
|----------------|------------------|
| 1. KNOB        | 9. SEAL CUP      |
| 2. NUT         | 10. SPRING PLATE |
| 3. PIN         | 11. NUT          |
| 4. SHAFT       | 12. SPRING       |
| 5. O-RING SEAL | 13. COVER SEAL   |
| 6. VALVE BODY  | 14. COVER        |
| 7. WASHER      | 15. SCREW (2)    |
| 8. SEAL        |                  |

TA 237483

**BRAKE SYSTEM.**

3-176. TRAILER SUPPLY VALVE REPAIR (Continued).		
LOCATION/ITEM	ACTION	REMARKS
<p><b>CAUTION</b> The valve body and/or cover cannot be clamped in a vise Failure to heed caution will result in damage to trailer supply valve.</p>		
<p><u>A DISASSEMBLY</u></p>		
<p><b>WARNING</b> Cover is under spring force Wear eye protection when removing cover and spring Failure to heed warning can result in personal injury.</p>		
<p><b>NOTE</b> Nut (2) is used to secure valve to instrument panel.</p>		
1 Two screws (15)	Hold item (14) and remove two items (15)	Item (14) is under spring force.
2 Cover (14), cover seal (13), and spring (12).	Remove	Discard item (13).
3 Knob (1)	Install on item (4) and insert rod through pinhole	Prevents rotation of item (4) when removing item (11).
4 Nut (11)	Unscrew and remove from item (4).	
5 Spring plate (10), seal cup (9), seal (8), and washer (7).	Remove from item (4)	Discard item (9), item (8), and item (7).

**BRAKE SYSTEM.**  
**3-176. TRAILER SUPPLY VALVE REPAIR (Continued).**

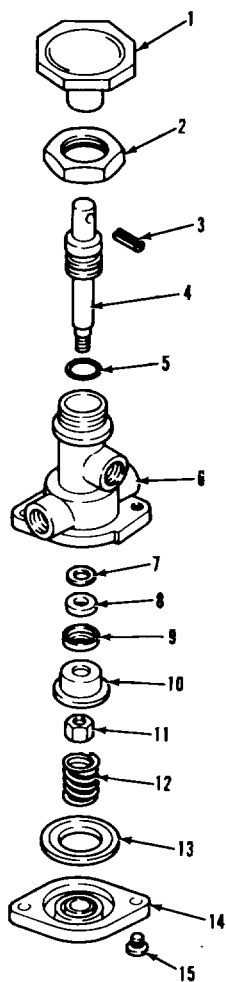

**LEGEND:**

- |                |                  |
|----------------|------------------|
| 1. KNOB        | 9. SEAL CUP      |
| 2. NUT         | 10. SPRING PLATE |
| 3. PIN         | 11. NUT          |
| 4. SHAFT       | 12. SPRING       |
| 5. O-RING SEAL | 13. COVER SEAL   |
| 6. VALVE BODY  | 14. COVER        |
| 7. WASHER      | 15. SCREW (2)    |
| 8. SEAL        |                  |

TA 237484

**BRAKE SYSTEM.**

<b>3-176. TRAILER SUPPLY VALVE REPAIR (Continued).</b>		
<b>LOCATION/ITEM</b>	<b>ACTION</b>	<b>REMARKS</b>
<u>A DISASSEMBLY (Continued)</u>		
6 Shaft (4)	Remove from item (6).	
7 Knob (1)	Remove from item (4).	
8 O-ring seal (5)	Remove from item (4)	Discard item (5).
<u>B CLEANING AND INSPECTION</u>		
9 All parts	Clean and inspect	Refer to paragraphs 3-4 and 3-5.
<u>C REASSEMBLY</u>		
10 O-ring seal (5)	Grease and install on item (4).	Use silicone grease.
11 Valve body (6)	Grease bore in area of item (5) and the seating surface of item (8).	
12 Shaft (4)	Grease and install in item (6).	
13 Washer (7)	Install on step of item (4).	
14 Seal cup (9) and seal (8)	Assemble, grease, and install onto step of item (4)	Item (8) facing item (7).
15 Spring plate (10)	Install on step of item (4) with the open end towards item (14).	
<b>3-1040</b>		



**BRAKE SYSTEM.**  
**3-176. TRAILER SUPPLY VALVE REPAIR (Continued).**

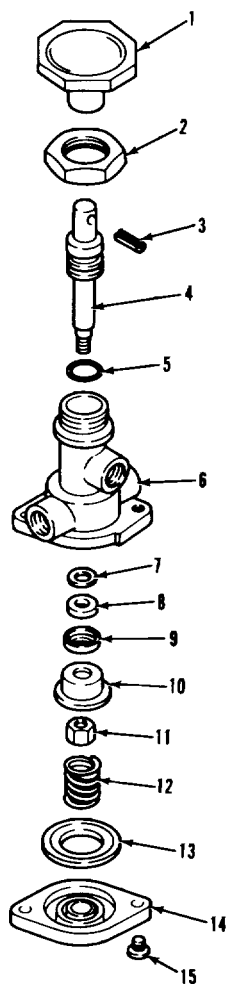

**LEGEND:**

- |                |                  |
|----------------|------------------|
| 1. KNOB        | 9. SEAL CUP      |
| 2. NUT         | 10. SPRING PLATE |
| 3. PIN         | 11. NUT          |
| 4. SHAFT       | 12. SPRING       |
| 5. O-RING SEAL | 13. COVER SEAL   |
| 6. VALVE BODY  | 14. COVER        |
| 7. WASHER      | 15. SCREW (2)    |
| 8. SEAL        |                  |

TA 237485

**BRAKE SYSTEM.**

3-176. TRAILER SUPPLY VALVE REPAIR (Continued).		
LOCATION/ITEM	ACTION	REMARKS
C REASSEMBLY (Continued).		
<b>NOTE</b>		
<b>The nut must be torqued for the trailer supply valve to operate.</b>		
16 Nut (11)	Apply thread locking compound and install on item (4) Tighten to 38 lb.-in necessary	Make sure item (10) is centered on item (4). Recenter item (10) if Install item (1) and insert rod through pinhole to prevent item (4) from turning.
17 Cover seal (13) facing in and steel insert side facing item (12).	Install with rubber surface	
18 Spring plate (10) and cover seal (13).	Grease sealing surfaces.	
19 Spring (12)	Install.	
20 Cover (14) items (15).	Install and secure with two	
<b>NOTE</b>		
<b>Follow-on maintenance action required: Install trailer supply valve (para 3-175).</b>		
<b>3-1042</b>		

**BRAKE SYSTEM.**  
**3-176. TRAILER SUPPLY VALVE REPAIR (Continued).**

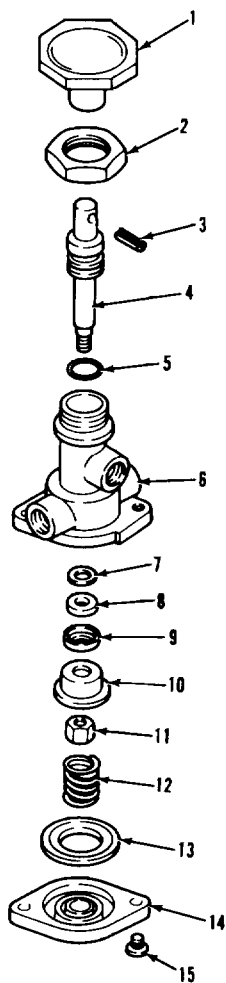

**LEGEND:**

- |                |                  |
|----------------|------------------|
| 1. KNOB        | 9. SEAL CUP      |
| 2. NUT         | 10. SPRING PLATE |
| 3. PIN         | 11. NUT          |
| 4. SHAFT       | 12. SPRING       |
| 5. O-RING SEAL | 13. COVER SEAL   |
| 6. VALVE BODY  | 14. COVER        |
| 7. WASHER      | 15. SCREW (2)    |
| 8. SEAL        |                  |

**BRAKE SYSTEM.**

**3-176. TRAILER SUPPLY VALVE REPAIR.**

**THIS TASK COVERS**

- a. Removal.
- b. Cleaning and Inspection.
- c. Installation.

INITIAL SETUP

APPLICABLE CONFIGURATIONS  
All.

EQUIPMENT CONDITION  
PARAGRAPH  
TM 9-2320-283-10.

CONDITION DESCRIPTION  
Air system draincocks  
opened.

TEST EQUIPMENT  
None.

SPECIAL TOOLS  
None.

MATERIALS/PARTS (P/N)  
None.

PERSONNEL REQUIRED  
One (MOS-63S).

SPECIAL ENVIRONMENTAL CONDITIONS  
None.

REFERENCES (TM)  
TM 9-2320-283-10.

GENERAL SAFETY INSTRUCTIONS  
Engine off.  
Transmission in neutral.  
Park brake set.

TROUBLESHOOTING REFERENCES  
Paragraph 2-11.

**BRAKE SYSTEM.**  
**3-177. RELAY VALVE REPLACEMENT (Continued).**

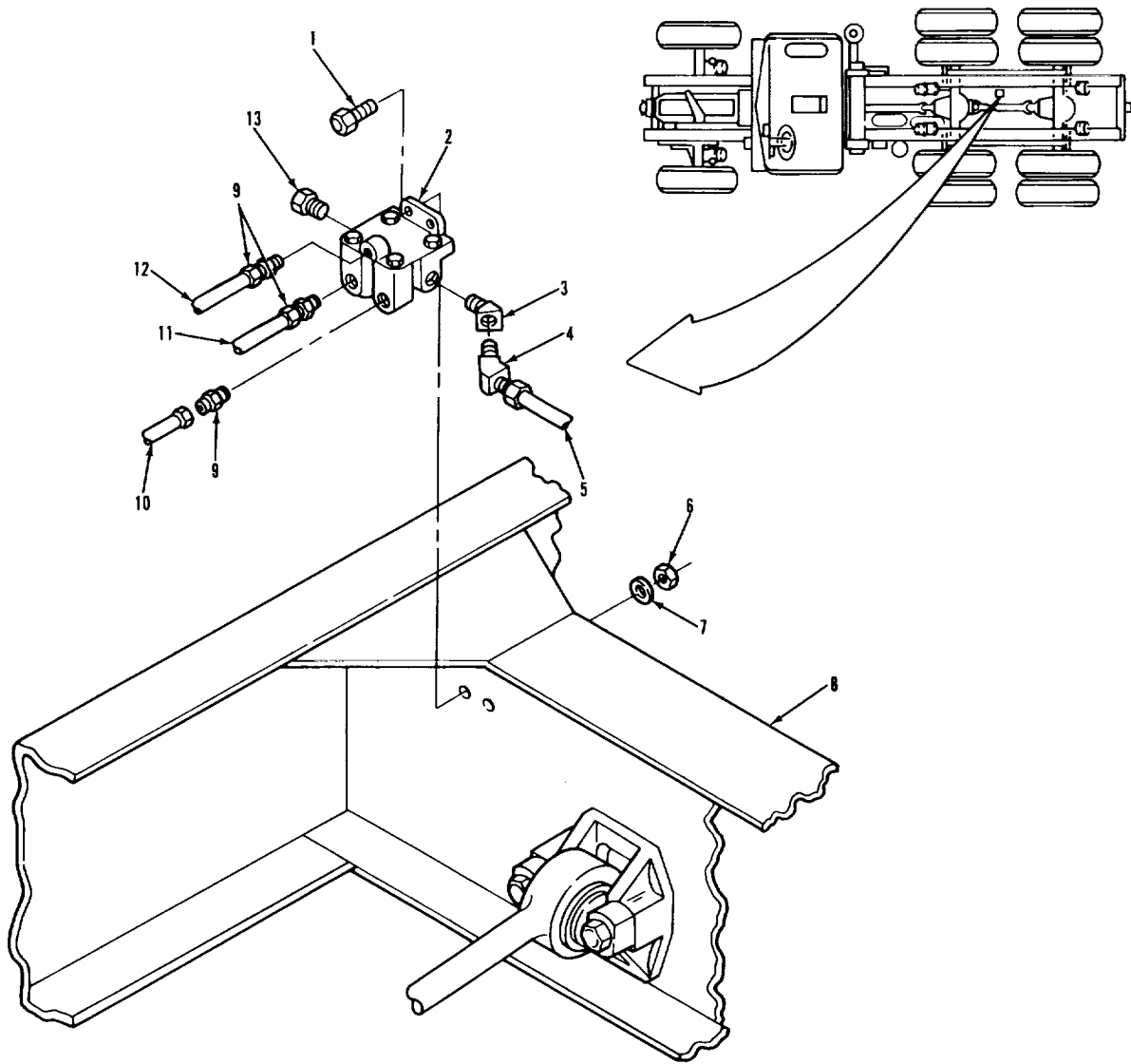

3-1045

**BRAKE SYSTEM.**

3-177. RELAY VALVE REPLACEMENT (Continued).		
LOCATION/ITEM	ACTION	REMARKS
<p><b><u>WARNING</u></b>  <b>Never work on air system components without first draining air pressure. Failure to follow this precaution can result in serious injury.</b></p>		
<u>A REMOVAL</u>		
1 Tube (5)	Remove from item (4)	Tag for identification.
2 Tube (10)	Remove from item (9)	Tag for identification.
3 Tube (11)	Remove from item (9)	Tag for identification.
4 Tube (12)	Remove from item (9)	Tag for identification.
5 Two capscrews (1), nuts (6), and washers (7)	a Remove from item (2). b Remove item (2) from item (8).	
6 Valve (2)	Place in suitable vise.	
7 Elbow (4)	Remove from item (3)	Tag for identification.
8 Elbow (3)	Remove from item (2)	Tag for identification.
9 Three connectors (9).	Remove from item (2)	Tag for identification.
10 Plug (13)	Remove from item (2)	Tag for identification.
11 Valve (2)	Remove from vise.	
<u>B CLEANING AND INSPECTION</u>		
12 All metal parts	Clean and inspect	Refer to paragraphs 3-4 and 3-5.

**BRAKE SYSTEM.**  
**3-177. RELAY VALVE REPLACEMENT (Continued).**

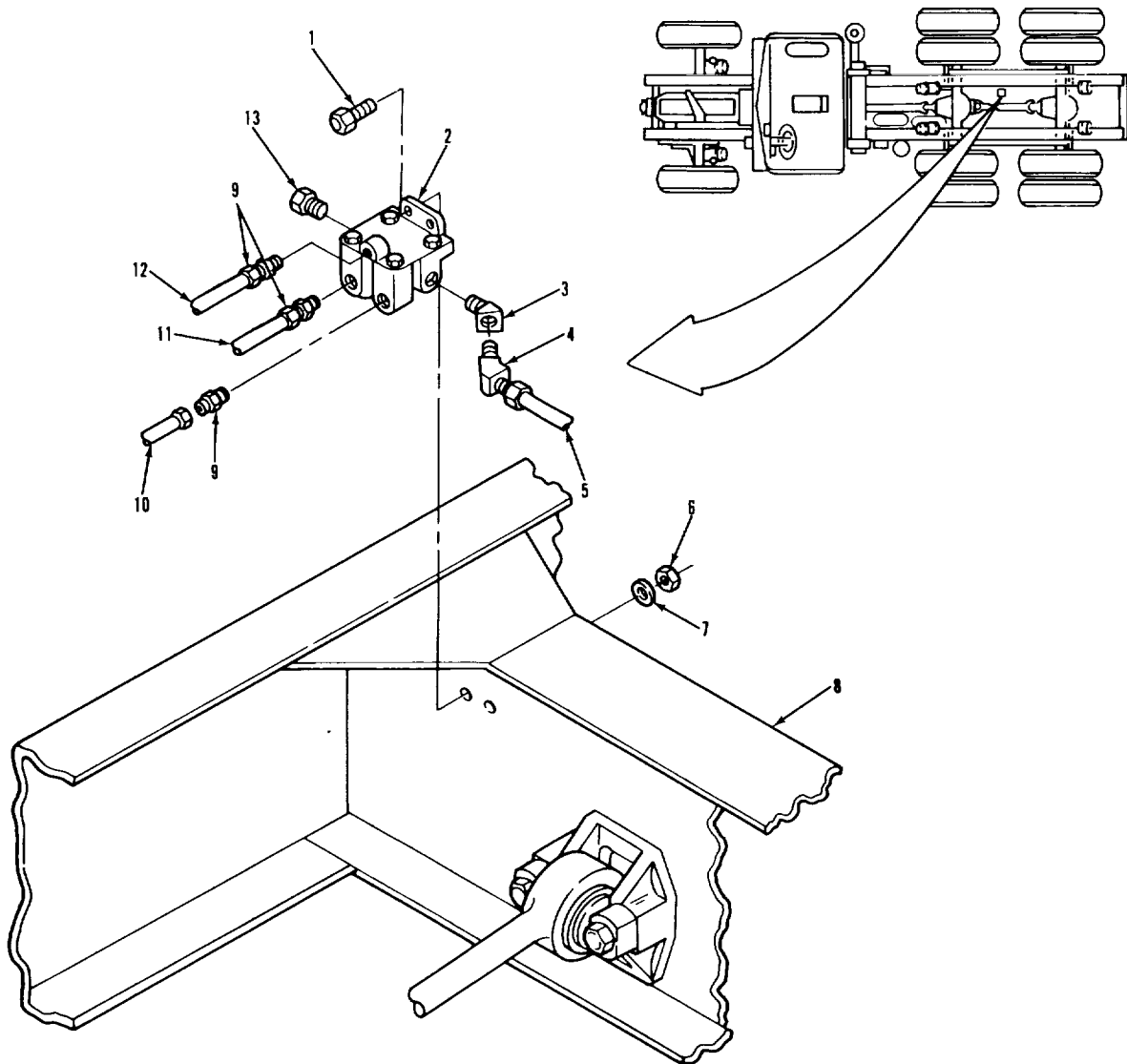

**LEGEND:**

- |                         |   |
|-------------------------|---|
| 1. HEXAGON CAPSCROW (2) | 8. REAR SUSPENSION CROSSMEMBER ASSEMBLY |
| 2. RELAY VALVE          | 9. CONNECTOR (3)                        |
| 3. STREET ELBOW         | 10. NONMETALLIC TUBE                    |
| 4. ELBOW                | 11. NONMETALLIC TUBE                    |
| 5. NONMETALLIC TUBE     | 12. NONMETALLIC TUBE                    |
| 6. HEXAGON HEAD NUT (2) | 13. PIPE PLUG                           |
| 7. FLAT WASHER (2)      |   |

TA 237488

**BRAKE SYSTEM.**

<b>3-177. RELAY VALVE REPLACEMENT (Continued).</b>		
<b>LOCATION/ITEM</b>	<b>ACTION</b>	<b>REMARKS</b>
<u>C INSTALLATION</u>		
13 Valve (2)	Place in suitable vise.	
14 Plug (13)	a Wrap threads with thread sealing tape. b Install in item (2).	Refer to paragraph 3-7.
15 Three connectors (9)	a Wrap threads with thread sealing tape. b Install in item (2)	Refer to paragraph 3-7. Smaller item (9) installed at top.
16 Elbow (3)	a Wrap threads with thread sealing tape. b Install in item (2).	Refer to paragraph 3-7.
17 Elbow (4)	a Wrap threads with thread sealing tape.	Refer to paragraph 3-7.
b Install in item (2).		
18 Valve (2)	a Remove from vise. b Line up holes in item (2) with holes in item (8). c Secure with two items (1), (6), and (7).	
19 Tube (12)	Install on item (9).	
20 Tube (11)	Install on item (9).	
21 Tube (10)	Install on item (9).	



**BRAKE SYSTEM.**

**3-177. RELAY VALVE REPLACEMENT (Continued).**

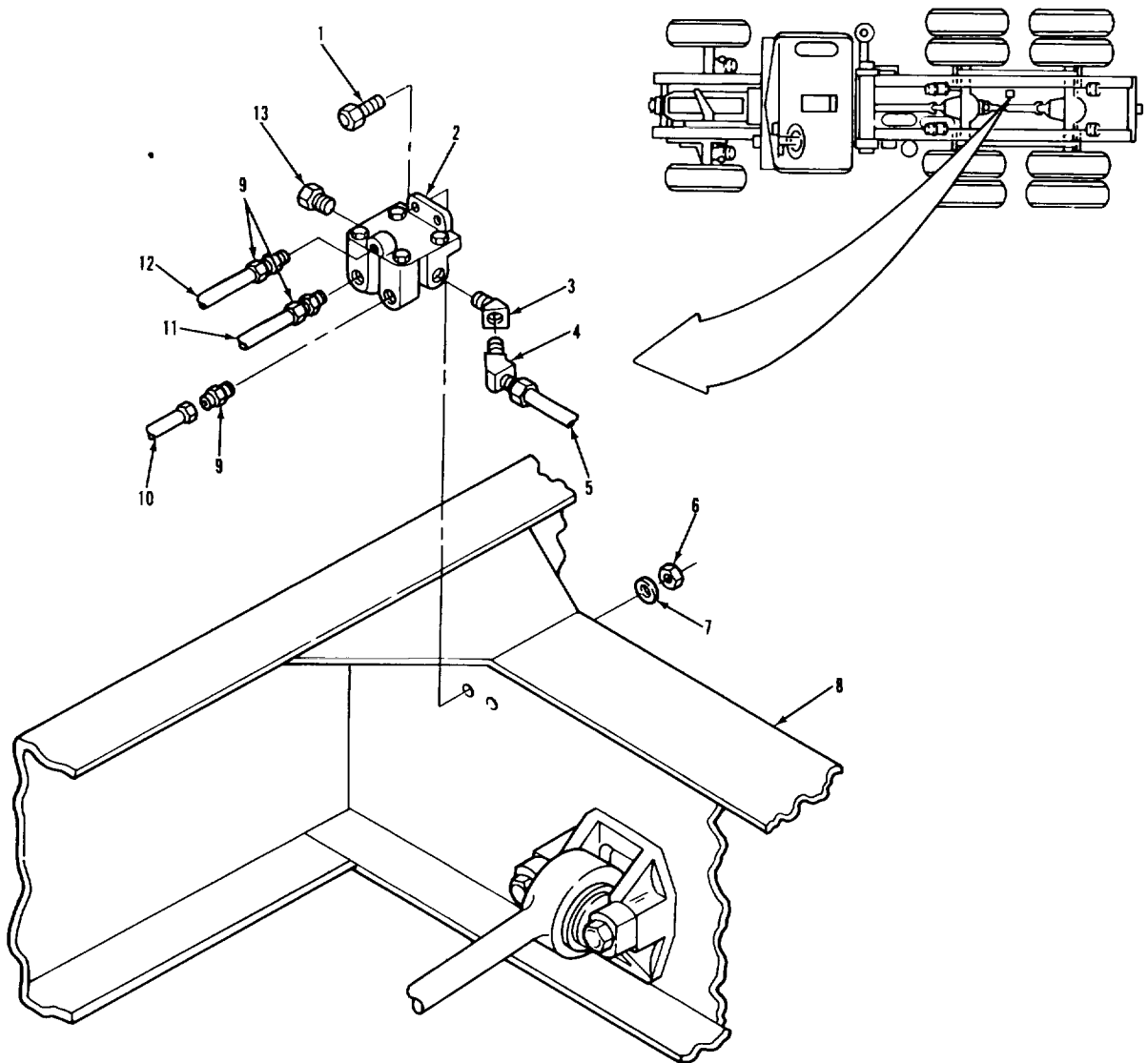

**LEGEND:**

- |                         |   |
|-------------------------|---|
| 1. HEXAGON CAPSCREW (2) | 8. REAR SUSPENSION CROSSMEMBER ASSEMBLY |
| 2. RELAY VALVE          | 9. CONNECTOR (3)                        |
| 3. STREET ELBOW         | 10. NONMETALLIC TUBE                    |
| 4. ELBOW                | 11. NONMETALLIC TUBE                    |
| 5. NONMETALLIC TUBE     | 12. NONMETALLIC TUBE                    |
| 6. HEXAGON HEAD NUT (2) | 13. PIPE PLUG                           |
| 7. FLAT WASHER (2)      |   |

TA 237489

**BRAKE SYSTEM.**

3-177. RELAY VALVE REPLACEMENT (Continued).		
LOCATION/ITEM	ACTION	REMARKS
<u>C INSTALLATION (Continued).</u>		
22 Tube (5)	Install on item (4).	
	<b>NOTE</b> <b>Follow on maintenance action required:</b> <b>Close air system draincocks and</b> <b>start engine (TM 9-2320-283-10).</b> <b>Check air system for leaks (para</b> <b>3-8).</b>	

**BRAKE SYSTEM.**  
**3-177. RELAY VALVE REPLACEMENT (Continued).**

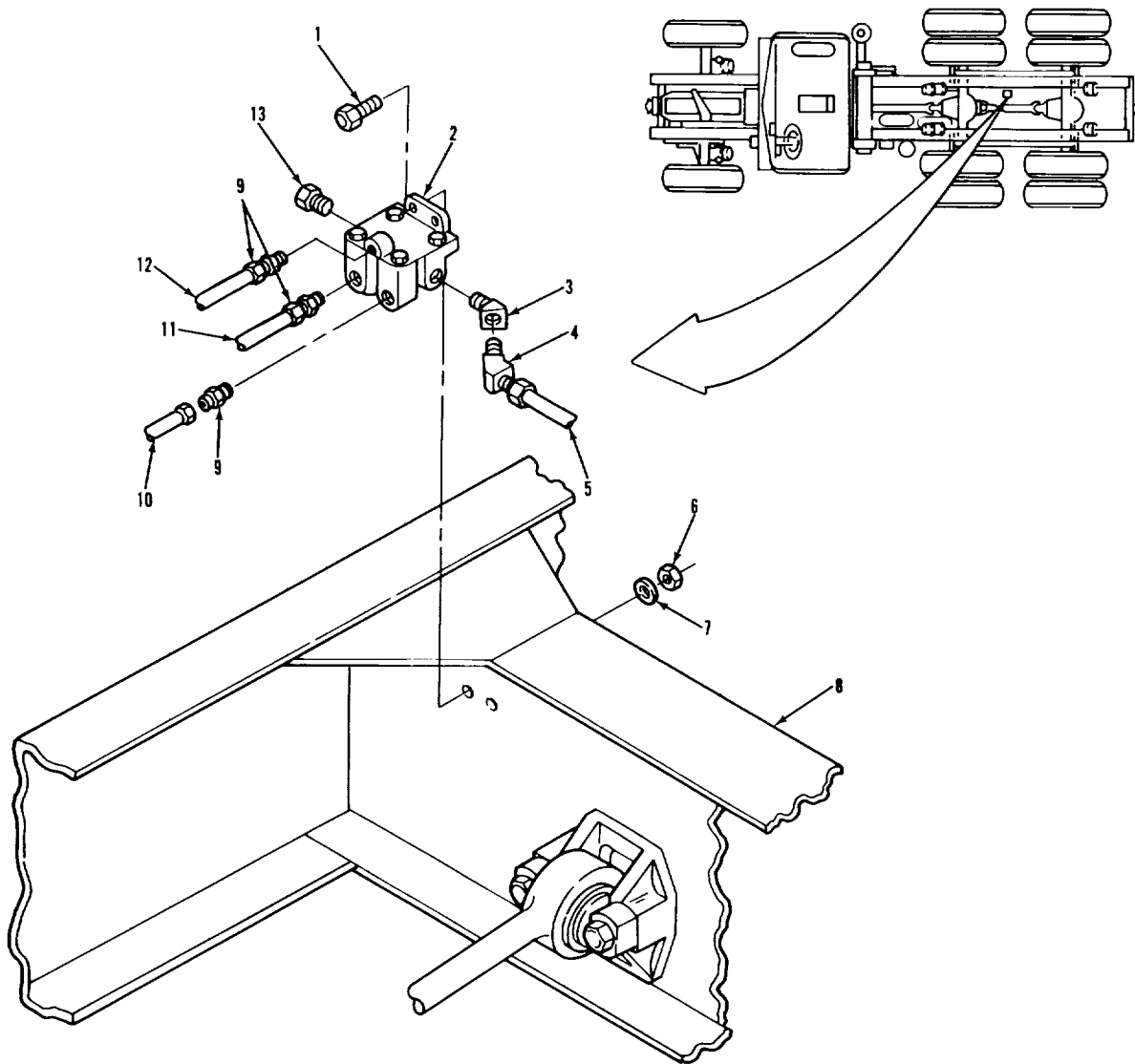

**LEGEND:**

- |                         |   |
|-------------------------|---|
| 1. HEXAGON CAPSCREW (2) | 8. REAR SUSPENSION CROSSMEMBER ASSEMBLY |
| 2. RELAY VALVE          | 9. CONNECTOR (3)                        |
| 3. STREET ELBOW         | 10. NONMETALLIC TUBE                    |
| 4. ELBOW                | 11. NONMETALLIC TUBE                    |
| 5. NONMETALLIC TUBE     | 12. NONMETALLIC TUBE                    |
| 6. HEXAGON HEAD NUT (2) | 13. PIPE PLUG                           |
| 7. FLAT WASHER (2)      |   |

TA 237490

**BRAKE SYSTEM.**

**3-178. FORWARD-REAR AXLE QUICK RELEASE VALVE REPLACEMENT.**

**THIS TASK COVERS**

- a. Removal.
- b. Cleaning and Inspection.
- c. Installation.

INITIAL SETUP

APPLICABLE CONFIGURATIONS

All.

EQUIPMENT CONDITION

PARAGRAPH

TM 9-2320-283-10.

CONDITION DESCRIPTION

Air system draincocks opened.

TEST EQUIPMENT

None.

SPECIAL TOOLS

None.

MATERIALS/PARTS IP/N)

Tape, thread sealing  
Item 32, Appendix C.  
Solution, soap  
Item 28, Appendix C.

PERSONNEL REQUIRED

One (MOS-63S5).

SPECIAL ENVIRONMENTAL CONDITIONS

None.

REFERENCES (TM)

TM 9-2320-283-10.  
Transmission in neutral.  
Park brake set.

GENERAL SAFETY INSTRUCTIONS

Engine off.

TROUBLESHOOTING REFERENCES

Paragraph 2-11.

**BRAKE SYSTEM.**

**3-178. FORWARD-REAR AXLE QUICK RELEASE VALVE REPLACEMENT (Continued).**

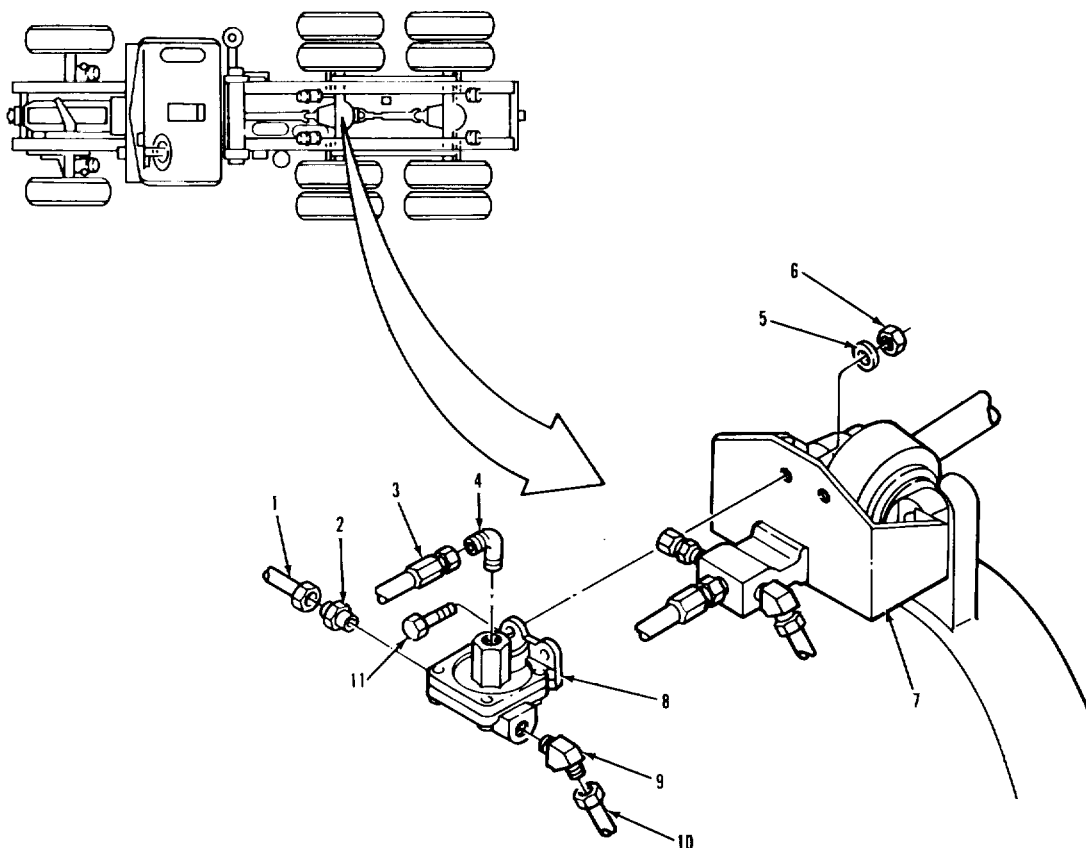

**LEGEND:**

- |                         |                           |
|-------------------------|---------------------------|
| 1. NONMETALLIC TUBE     | 7. VALVE MOUNTING BRACKET |
| 2. CONNECTOR            | 8. QUICK RELEASE VALVE    |
| 3. BRAKE HOSE ASSEMBLY  | 9. ELBOW                  |
| 4. ELBOW                | 10. NONMETALLIC TUBE      |
| 5. FLAT WASHER (2)      | 11. SCREW (2)             |
| 6. HEXAGON HEAD NUT (2) |                           |

TA 237491

**BRAKE SYSTEM.**

3-178. FORWARD-REAR AXLE QUICK RELEASE VALVE REPLACEMENT (Continued).		
LOCATION/ITEM	ACTION	REMARKS
<p><b>WARNING</b>                      Never work on air system components without first draining air pressure. Failure to follow this precaution can result in serious personal injury.</p>		
<u>A REMOVAL</u>		
1 Hose (3)	Remove from item (4)	Tag for identification.
2 Tube (1)	Remove from item (2)	Tag for identification.
3 Tube (10)	Remove from item (9)	Tag for identification.
4 Two screws (11), washers (5), and nuts (6)	a Remove from item (8). b Remove item (8) from item (7).	
5 Valve (8)	Place in suitable vise.	
6 Elbow (9)	Remove from item (8)	Tag for identification.
7 Elbow (4)	Remove from item (8)	Tag for identification.
8 Connector (2)	a Remove from item (8) b Remove item (8) from vise.	Tag for identification.
<u>B CLEANING AND INSPECTION</u>		
9 All metal parts	Clean and inspect	Refer to paragraphs 3-4 and 3-5.
<b>3-1054</b>		

**BRAKE SYSTEM.**

**3-178. FORWARD-REAR AXLE QUICK RELEASE VALVE REPLACEMENT (Continued).**

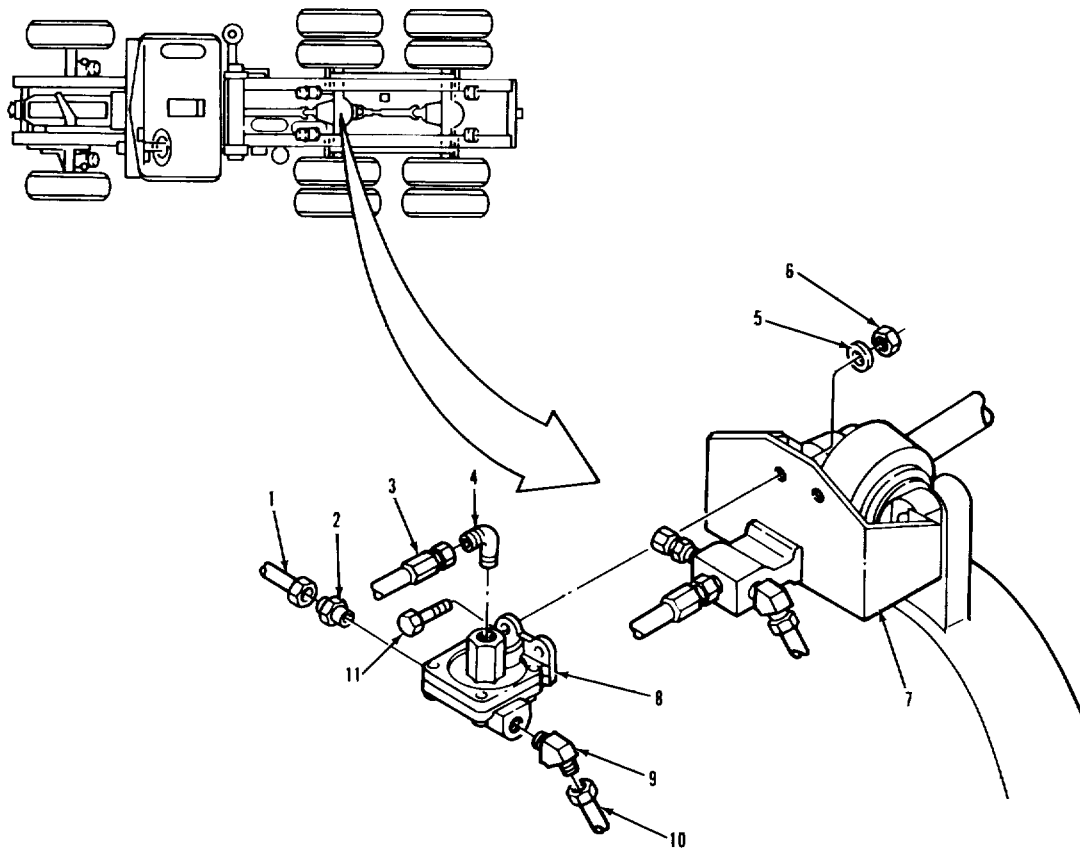

**LEGEND:**

- 1. NONMETALLIC TUBE
- 2. CONNECTOR
- 3. BRAKE HOSE ASSEMBLY
- 4. ELBOW
- 5. FLAT WASHER (2)
- 6. HEXAGON HEAD NUT (2)

- 7. VALVE MOUNTING BRACKET
- 8. QUICK RELEASE VALVE
- 9. ELBOW
- 10. NONMETALLIC TUBE
- 11. SCREW (2)

TA 237492

**BRAKE SYSTEM.**

3-178. FORWARD-REAR AXLE QUICK RELEASE VALVE REPLACEMENT (Continued).		
LOCATION/ITEM	ACTION	REMARKS
<u>C INSTALLATION.</u>		
10 Valve (8)	Place in suitable vise.	
11 Connector (2)	a Wrap threads with thread sealing tape. b Install on item (8).	Refer to paragraph 3-7.
12 Elbow (4)	a Wrap threads with thread sealing tape. b Install on item (8).	Refer to paragraph 3-7.
13 Elbow (9)	a Wrap threads with thread sealing tape. b Install on item (8). c Remove item (8) from vise.	Refer to paragraph 3-7.
14 Valve (8)	a Line up holes in item (8) with holes in item (7). b Secure with two items (11), (5), and (6).	
15 Tube (10)	Install on item (9).	
16 Tube (1)	Install on item (2).	
17 Hose (3)	Install on item (4).	
<p><b>NOTE</b>  <b>Follow-on maintenance action required:</b>  <b>Close air system draincocks and start engine (TM 9-2320-283-10).</b>  <b>Check air system for leaks (para 3-8).</b></p>		



**BRAKE SYSTEM.**

**3-178. FORWARD-REAR AXLE QUICK RELEASE VALVE REPLACEMENT (Continued).**

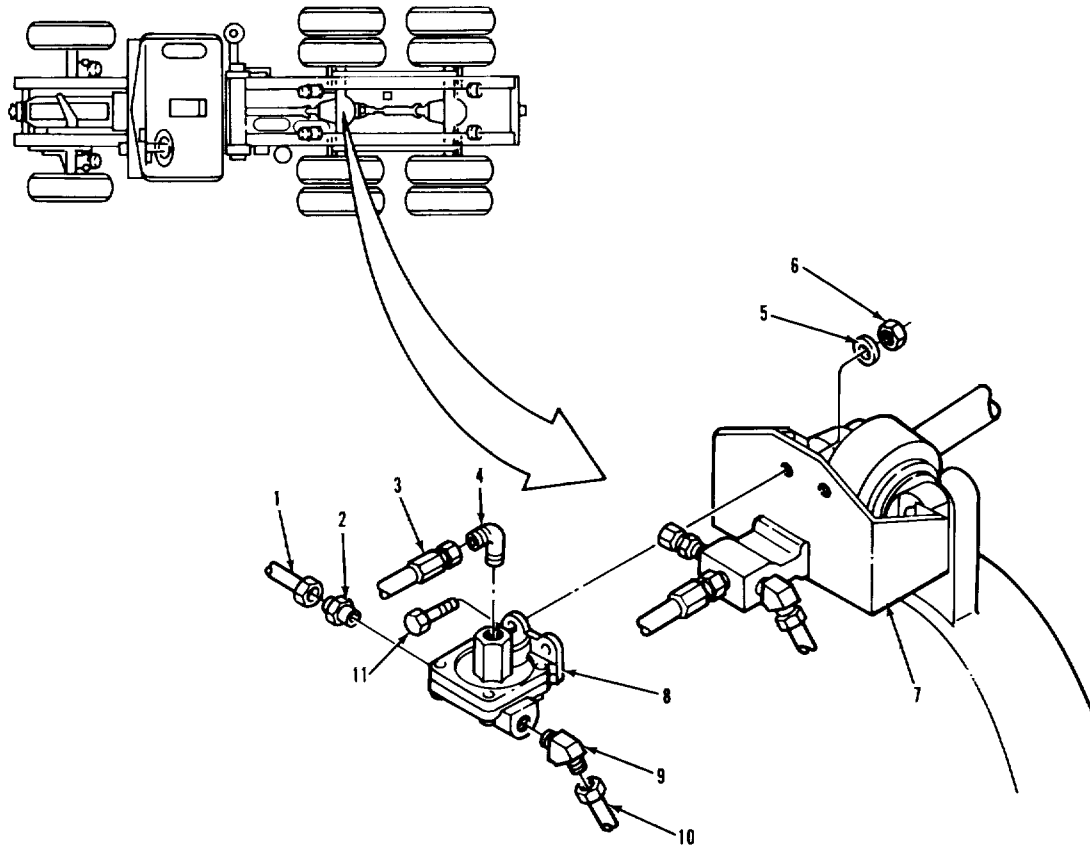

**LEGEND:**

- |                         |                           |
|-------------------------|---------------------------|
| 1. NONMETALLIC TUBE     | 7. VALVE MOUNTING BRACKET |
| 2. CONNECTOR            | 8. QUICK RELEASE VALVE    |
| 3. BRAKE HOSE ASSEMBLY  | 9. ELBOW                  |
| 4. ELBOW                | 10. NONMETALLIC TUBE      |
| 5. FLAT WASHER (2)      | 11. SCREW (2)             |
| 6. HEXAGON HEAD NUT (2) |                           |

TA 237493

**BRAKE SYSTEM.**

**3-179. REAR-REAR AXLE QUICK RELEASE VALVE REPLACEMENT.**

**THIS TASK COVERS**

- a. Removal.
- b. Cleaning and Inspection.
- c. Installation.

INITIAL SETUP

<u>APPLICABLE CONFIGURATIONS</u> All	<u>EQUIPMENT CONDITION PARAGRAPH</u> TM 9-2320-283-10	<u>CONDITION DESCRIPTION</u> Air system draincocks opened.
---	--	---

TEST EQUIPMENT

None.

SPECIAL TOOLS

None.

MATERIALS/PARTS (P/N)

Tape, thread sealing  
Item 24, Appendix C.  
Solution, soap  
Item 21, Appendix C.

PERSONNEL REQUIRED

One (MOS-63S )

SPECIAL ENVIRONMENTAL CONDITIONS

None.

REFERENCES (TM)

TM 9-2320-283-10  
Transmission in neutral.  
Park brake set.

GENERAL SAFETY INSTRUCTIONS

Engine off.

TROUBLESHOOTING REFERENCES

Paragraph 2-11.

**BRAKE SYSTEM.**

**3-179. REAR-REAR AXLE QUICK RELEASE VALVE REPLACEMENT (Continued).**

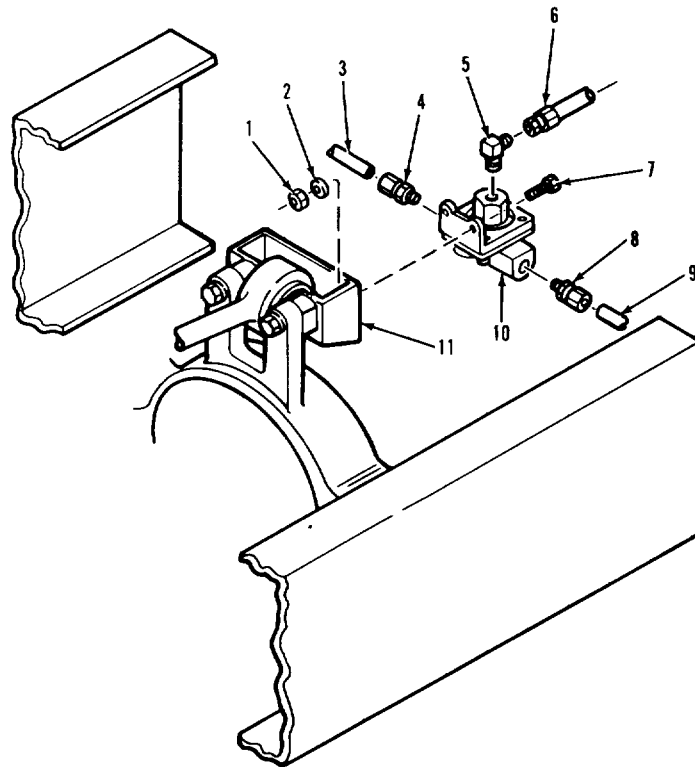
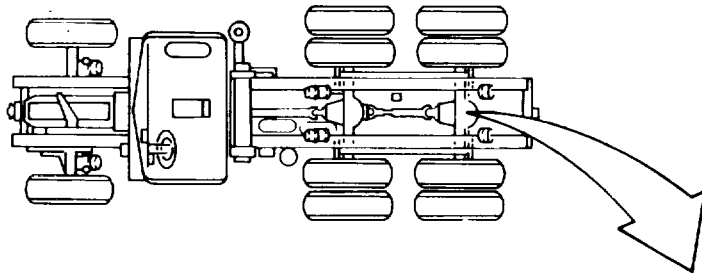

**LEGEND:**

- 1. HEXAGON HEAD NUT (2)
- 2. FLAT WASHER (2)
- 3. NONMETALLIC TUBE
- 4. CONNECTOR
- 5. ELBOW
- 6. REAR AXLE BRAKE HOSE ASSEMBLY

- 7. SCREW (2)
- 8. CONNECTOR
- 9. NONMETALLIC TUBE
- 10. QUICK RELEASE VALVE
- 11. VALVE MOUNTING BRACKET

TA 237494

**BRAKE SYSTEM.**

3-179. REAR-REAR AXLE QUICK RELEASE VALVE REPLACEMENT (Continued).		
LOCATION/ITEM	ACTION	REMARKS
<p><b>WARNING</b>                      Never work on air system components without first draining air pressure. Failure to follow this precaution can result in serious personal injury.</p>		
<u>A REMOVAL</u>		
1 Hose (6)	Remove from item (5)	Tag for identification.
2 Tube (9)	Remove from item (8)	Tag for identification.
3 Tube (3)	Remove from item (4)	Tag for identification.
4 Two screws (7), washers (2), and nuts (1)	a Remove from item (10). b Remove item (10) from item (11).	
5 Valve (10)	Place in suitable vise.	
6 Elbow (5)	Remove from item (10)	Tag for identification.
7 Connector (4)	Remove from item (10)	Tag for identification.
8 Connector (8)	a Remove from item (10) b Remove item (10) from vise.	Tag for identification.
<u>B CLEANING AND INSPECTION</u>		
9 All metal parts	Clean and inspect	Refer to paragraphs 3-4 and 3-5.

**BRAKE SYSTEM.**

**3-179. REAR-REAR AXLE QUICK RELEASE VALVE REPLACEMENT (Continued).**

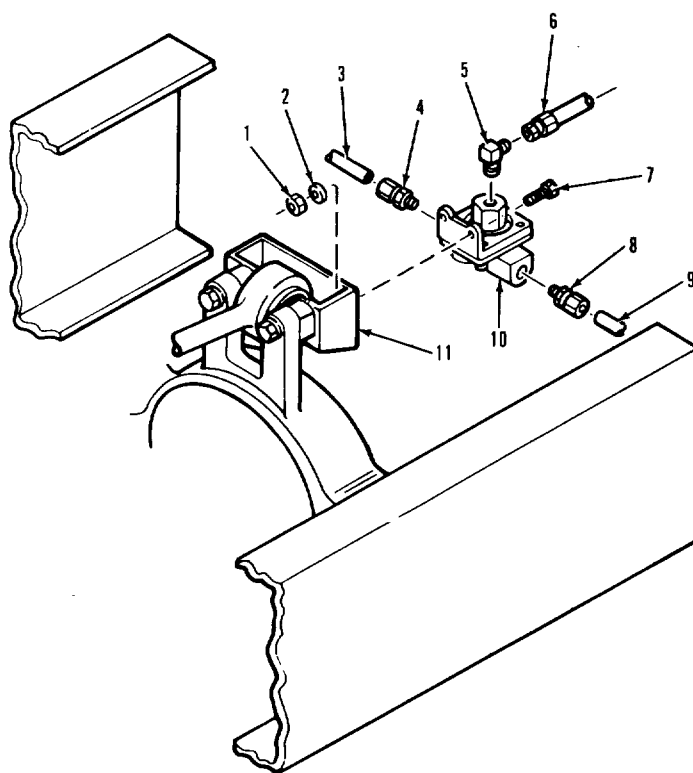
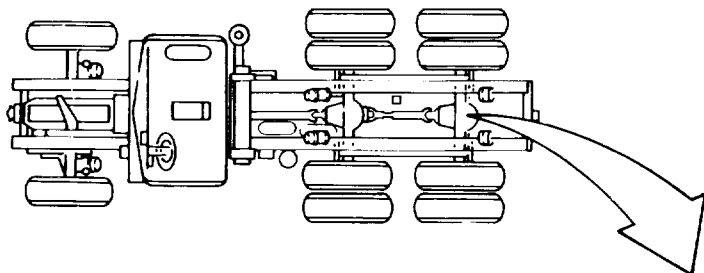

**LEGEND:**

- 1. HEXAGON HEAD NUT (2)
- 2. FLAT WASHER (2)
- 3. NONMETALLIC TUBE
- 4. CONNECTOR
- 5. ELBOW
- 6. REAR AXLE BRAKE HOSE ASSEMBLY

- 7. SCREW (2)
- 8. CONNECTOR
- 9. NONMETALLIC TUBE
- 10. QUICK RELEASE VALVE
- 11. VALVE MOUNTING BRACKET

TA 237495

**BRAKE SYSTEM.**

3-179. REAR-REAR AXLE QUICK RELEASE VALVE REPLACEMENT (Continued).		
LOCATION/ITEM	ACTION	REMARKS
<u>C INSTALLATION.</u>		
10 Valve (10)	Place in suitable vise.	
11 Connector (8)	a Wrap threads with thread sealing tape. b Install on item (10).	Refer to paragraph 3-7.
12 Connector (4)	a Wrap threads with thread sealing tape. b Install on item (10).	Refer to paragraph 3-7.
13 Elbow (5)	a Wrap threads with thread sealing tape. b Install on item (10). c Remove item (10) from vise.	Refer to paragraph 3-7.
14 Valve (10)	a Line up holes in item (10) with holes in item (11). b Secure with two items (7), (2), and (1).	
15 Tube (3)	Install on item (4).	
16 Tube (9)	Install on item (8).	
17 Hose (6)	Install on item (5).	
<p><b>NOTE</b>  <b>Follow-on maintenance action required:</b>  <b>Close air system draincocks and start engine (TM 9-2320-283-10).</b>  <b>Check air system for leaks (para 3-8).</b></p>		
<p><b>3-1062</b></p>		

**BRAKE SYSTEM.**

**3-179. REAR-REAR AXLE QUICK RELEASE VALVE REPLACEMENT (Continued).**

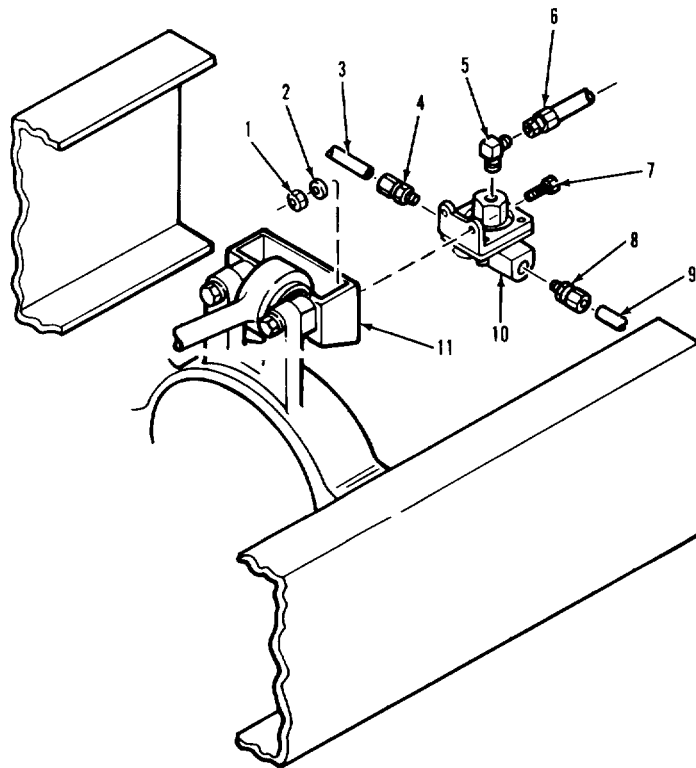
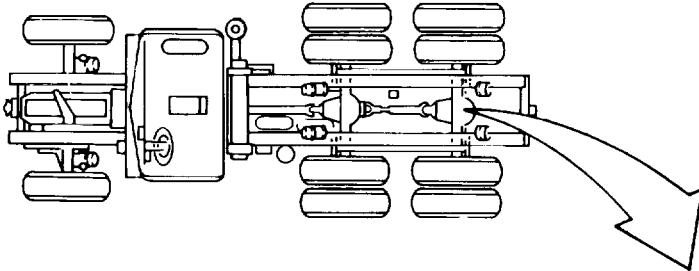

**LEGEND:**

- 1. HEXAGON HEAD NUT (2)
- 2. FLAT WASHER (2)
- 3. NONMETALLIC TUBE
- 4. CONNECTOR
- 5. ELBOW
- 6. REAR AXLE BRAKE HOSE ASSEMBLY

- 7. SCREW (2)
- 8. CONNECTOR
- 9. NONMETALLIC TUBE
- 10. QUICK RELEASE VALVE
- 11. VALVE MOUNTING BRACKET

**BRAKE SYSTEM.**

**3-180. MOUNTABLE TEE REPLACEMENT.**

**THIS TASK COVERS**

- a. Right -Hand Main Rail Mountable Tee Replacement.
- b. Forward-Rear Axle Mountable Tee Replacement.

**INITIAL SETUP**

**APPLICABLE CONFIGURATIONS**

All.

**EQUIPMENT CONDITION**

**PARAGRAPH**

TM 9-2320-283-10.

**CONDITION DESCRIPTION**

Air system draincocks opened.

**TEST EQUIPMENT**

None.

**SPECIAL TOOLS**

None.

**MATERIALS/PARTS (P/N)**

Tape, thread sealing  
Item 32, Appendix C.  
Solution, soap  
Item 28, Appendix C.

**PERSONNEL REQUIRED**

One (MOS-63S).

**SPECIAL ENVIRONMENTAL CONDITIONS**

None.

**REFERENCES (TM)**

TM 9-2320-283-10.

**GENERAL SAFETY INSTRUCTIONS**

Engine off.  
Transmission in neutral.  
Park brake set.

**TROUBLESHOOTING REFERENCES**

Paragraph 2-11.



**BRAKE SYSTEM.**

**3-180. MOUNTABLE TEE REPLACEMENT (Continued).**

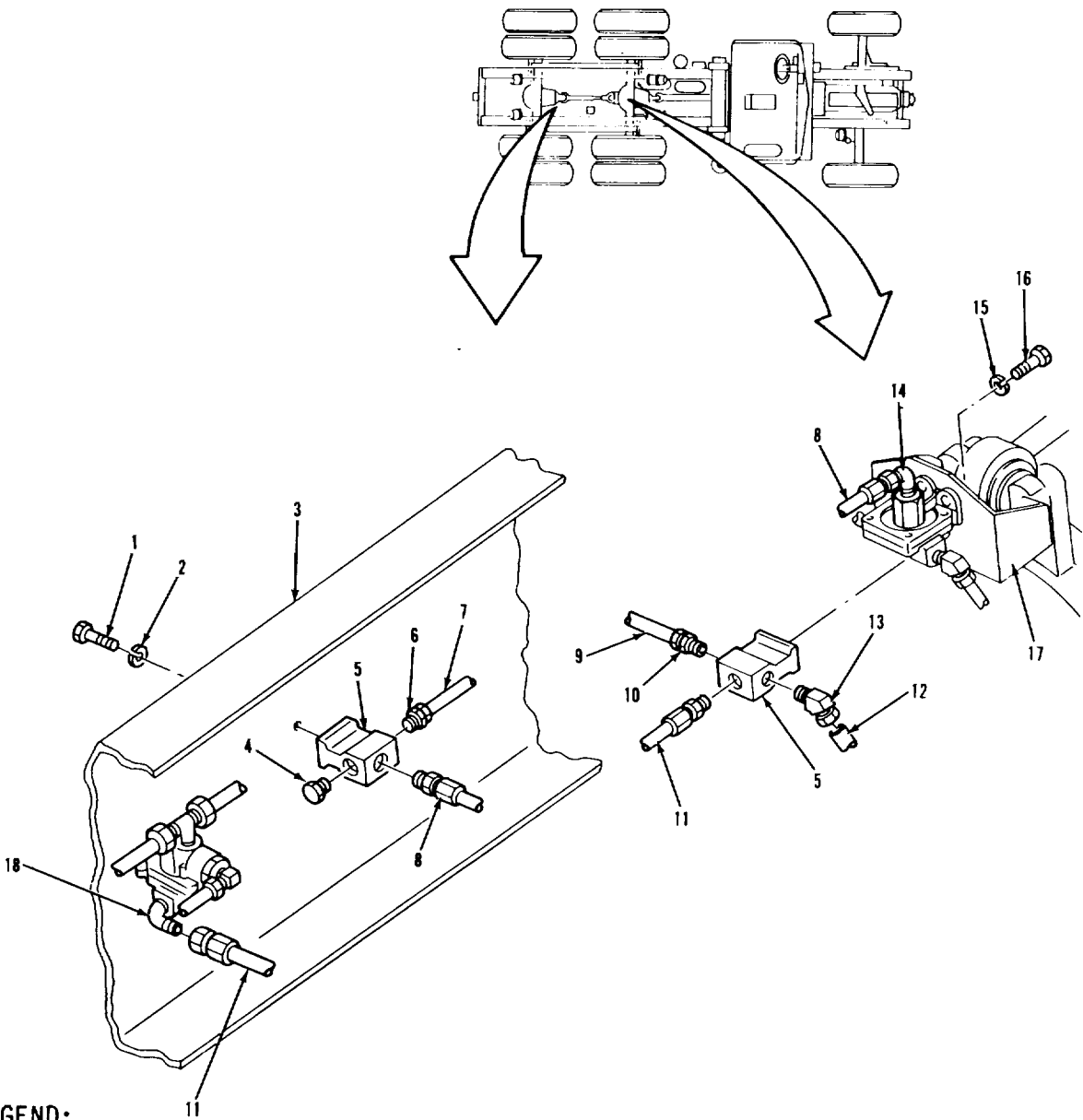

**LEGEND:**

- |                         |                            |
|-------------------------|----------------------------|
| 1. CAPSCREW             | 10. CONNECTOR              |
| 2. LOCKWASHER           | 11. AIR HOSE ASSEMBLY      |
| 3. RIGHT-HAND MAIN RAIL | 12. NONMETALLIC TUBE       |
| 4. PLUG                 | 13. ELBOW                  |
| 5. MOUNTABLE TEE        | 14. ELBOW                  |
| 6. CONNECTOR            | 15. LOCKWASHER             |
| 7. NONMETALLIC TUBE     | 16. CAPSCREW               |
| 8. BRAKE HOSE ASSEMBLY  | 17. VALVE MOUNTING BRACKET |
| 9. NONMETALLIC TUBE     | 18. ELBOW                  |

TA 237497

**BRAKE SYSTEM.**

<b>3-180. MOUNTABLE TEE REPLACEMENT (Continued).</b>		
<b>LOCATION/ITEM</b>	<b>ACTION</b>	<b>REMARKS</b>
<b><u>A. RIGHT-HAND MAIN RAIL MOUNTABLE TEE REPLACEMENT.</u></b>		
<b>NOTE</b>		
All three right-hand main rail mount- able tees are removed in same way. One mountable tee is shown here.		
1. Tube (7)	Remove from item (6).	
<b>NOTE</b>		
In the following step, hose (8) must be removed from elbow (14) before it can be removed from tee (5).		
2. Hose (8)	a. Remove from item (14). b. Remove from item (5).	
3. Plug (4)	Remove from item (5).	
4. Screw (1) and lockwasher (2).	a. Remove from item (5).  b. Remove item (5) from item (3). c. Remove item (6) from item (5).	
5. All metal parts	Clean and inspect	Refer to paragraphs 3-4 and 3-5.
6. Tee (5) with hole in item (3).	a. Line up hole in item (5)  b. Secure with items (1) and (2).	
7. Plug (4) and connector (6)	a. Wrap threads with thread sealing tape. b. Install on item (5).	
<b>3-1066</b>		

**BRAKE SYSTEM.**

**3-180. MOUNTABLE TEE REPLACEMENT (Continued).**

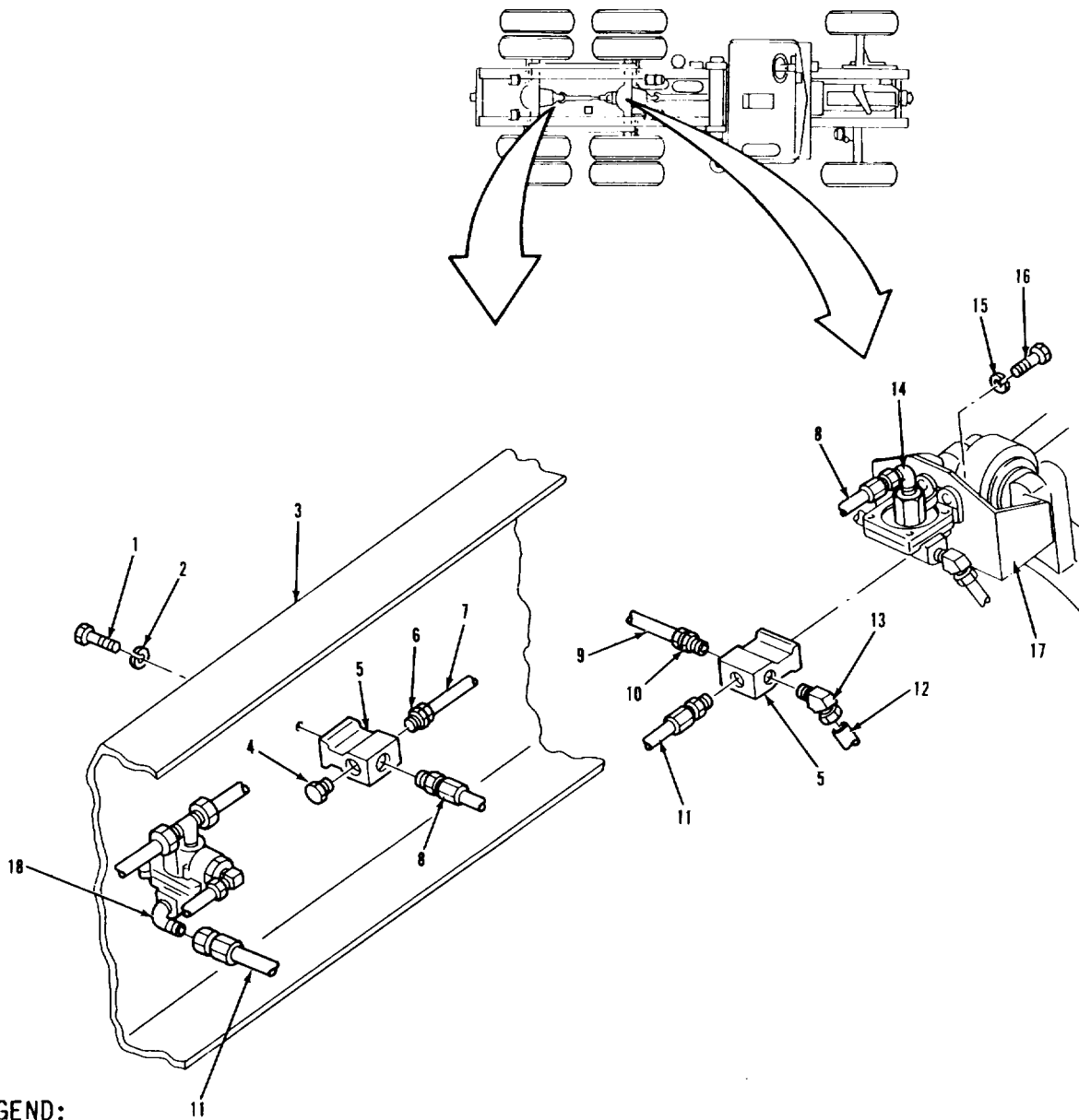

**LEGEND:**

- |                         |                            |
|-------------------------|----------------------------|
| 1. CAPSCREW             | 10. CONNECTOR              |
| 2. LOCKWASHER           | 11. AIR HOSE ASSEMBLY      |
| 3. RIGHT-HAND MAIN RAIL | 12. NONMETALLIC TUBE       |
| 4. PLUG                 | 13. ELBOW                  |
| 5. MOUNTABLE TEE        | 14. ELBOW                  |
| 6. CONNECTOR            | 15. LOCKWASHER             |
| 7. NONMETALLIC TUBE     | 16. CAPSCREW               |
| 8. BRAKE HOSE ASSEMBLY  | 17. VALVE MOUNTING BRACKET |
| 9. NONMETALLIC TUBE     | 18. ELBOW                  |

TA 237498

**BRAKE SYSTEM.**

<b>3-180. MOUNTABLE TEE REPLACEMENT (Continued).</b>		
<b>LOCATION/ITEM</b>	<b>ACTION</b>	<b>REMARKS</b>
<b><u>A. RIGHT-HAND MAIN RAIL MOUNTABLE TEE REPLACEMENT (Continued).</u></b>		
<b>NOTE</b>		
In the following step, hose (8) must be installed on tee (5) before it can be installed on elbow (14).		
8. Hose (8)	a. Install on item (5). b. Install on item (14).	
9. Tube (7)	a. Install on item (6). b. Go to follow-on maintenance.	
<b><u>B. FORWARD-REAR AXLE MOUNTABLE TEE REPLACEMENT. I</u></b>		
10. Tube (9)	Remove from item (10).	
<b>NOTE</b>		
In the following step, hose (11) must be removed from elbow (18) before it can be removed from tee (5).		
11. Hose (11)	a. Remove from item (18). b. Remove from item (5).	
12. Tube (12)	Remove from item (13).	
13. Screw (16) and	a. Remove from items (5) and lockwasher (15) (17). b. Remove item (5) from item (17).	
14. Connector (10)	Remove from item (5).	
15. Elbow (13)	Remove from item (5).	
<b>3-1068</b>		

**BRAKE SYSTEM.**

**3-180. MOUNTABLE TEE REPLACEMENT (Continued).**

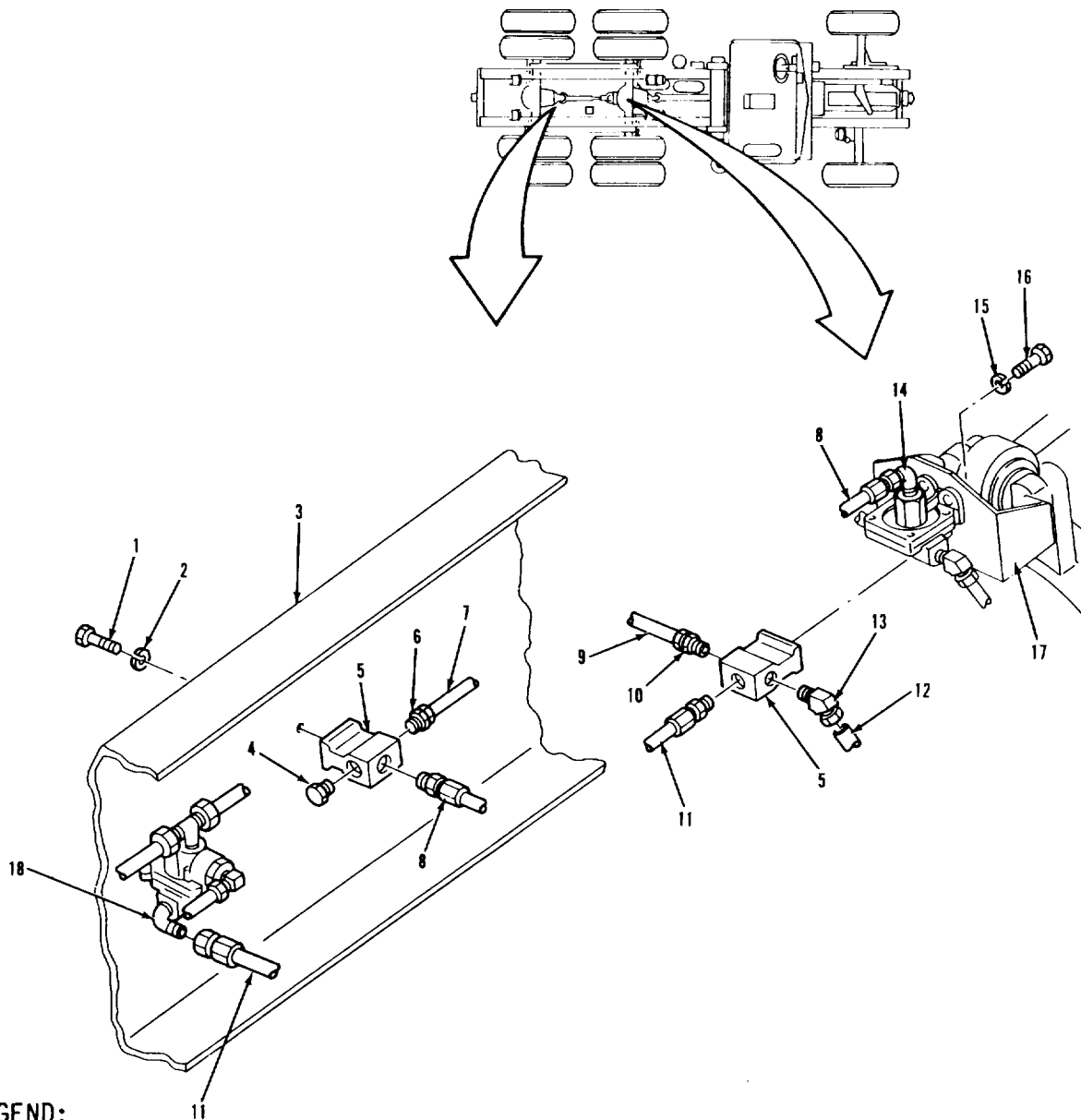

**LEGEND:**

- |                         |                            |
|-------------------------|----------------------------|
| 1. CAPSCREW             | 10. CONNECTOR              |
| 2. LOCKWASHER           | 11. AIR HOSE ASSEMBLY      |
| 3. RIGHT-HAND MAIN RAIL | 12. NONMETALLIC TUBE       |
| 4. PLUG                 | 13. ELBOW                  |
| 5. MOUNTABLE TEE        | 14. ELBOW                  |
| 6. CONNECTOR            | 15. LOCKWASHER             |
| 7. NONMETALLIC TUBE     | 16. CAPSCREW               |
| 8. BRAKE HOSE ASSEMBLY  | 17. VALVE MOUNTING BRACKET |
| 9. NONMETALLIC TUBE     | 18. ELBOW                  |

TA 237498

**BRAKE SYSTEM.**

<b>3-180. MOUNTABLE TEE REPLACEMENT (Continued).</b>		
<b>LOCATION/ITEM</b>	<b>ACTION</b>	<b>REMARKS</b>
<b><u>B. FORWARD-REAR AXLE MOUNTABLE TEE REPLACEMENT (Continued).</u></b>		
16. All metal parts	Clean and inspect	Refer to paragraphs 3-4 and 3-5.
17. Elbow (13)	a. Wrap threads with thread sealing tape. b. Install on item (5).	Refer to paragraph 3-7.
18. Connector (10)	a. Wrap threads with thread sealing tape. b. Install on item (5).	Refer to paragraph 3-7.
19. Tee (5)	a. Line up hole in item (5) with hole in item (17). b. Secure with item (16) and (15).	
20. Tube (12)	Install on item (13).	
<b>NOTE</b>		
In the following step, hose (11) must be installed on tee (5) before it can be installed on elbow (18).		
21. Hose (11)	a. Install on item (5). b. Install on item (18).	
22. Tube (9)	Install on item (10).	
<b>NOTE</b>		
Follow-on maintenance action required: Close air system draincocks and start engine (TM 9-2320-283-10). Check air system for leaks (para 3-8).		
<b>3-1070</b>		

**BRAKE SYSTEM.**

**3-180. MOUNTABLE TEE REPLACEMENT (Continued).**

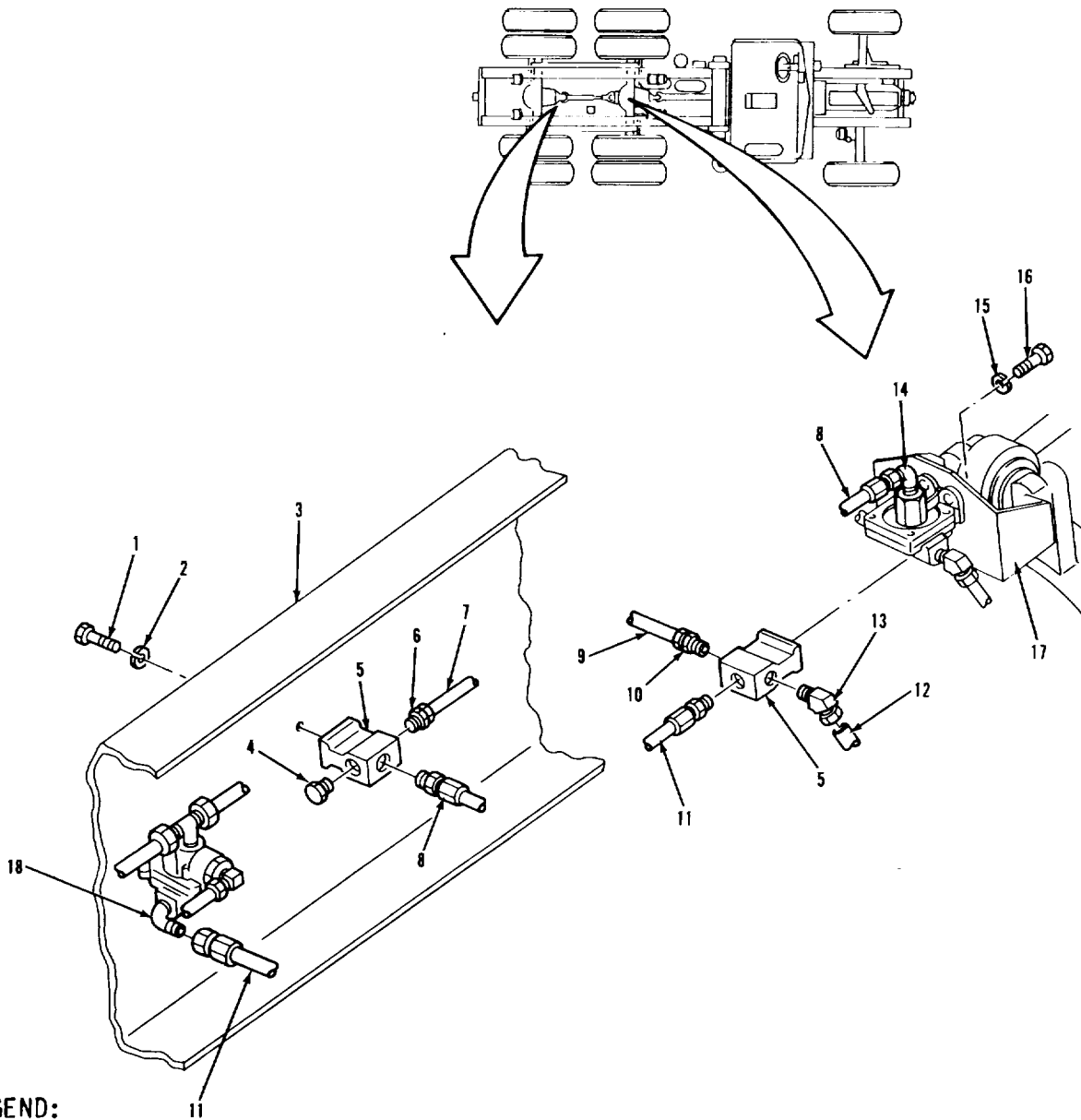

**LEGEND:**

- |                         |                            |
|-------------------------|----------------------------|
| 1. CAPSCREW             | 10. CONNECTOR              |
| 2. LOCKWASHER           | 11. AIR HOSE ASSEMBLY      |
| 3. RIGHT-HAND MAIN RAIL | 12. NONMETALLIC TUBE       |
| 4. PLUG                 | 13. ELBOW                  |
| 5. MOUNTABLE TEE        | 14. ELBOW                  |
| 6. CONNECTOR            | 15. LOCKWASHER             |
| 7. NONMETALLIC TUBE     | 16. CAPSCREW               |
| 8. BRAKE HOSE ASSEMBLY  | 17. VALVE MOUNTING BRACKET |
| 9. NONMETALLIC TUBE     | 18. ELBOW                  |

TA 237499

**BRAKE SYSTEM.**

**3-181. FRONT AXLE RATIO VALVE REPLACEMENT.**

**This task covers:**

- a. Removal
- b. Cleaning
- c. Installation

**INITIAL SETUP:**

<u>APPLICABLE CONFIGURATIONS</u>	<u>EQUIPMENT CONDITION PARAGRAPH</u>	<u>CONDITION DESCRIPTION</u>
All.	TM 9-2320-283-10.	Air system draincocks opened.
<u>TEST EQUIPMENT</u>		
None.		
<u>SPECIAL TOOLS</u>		
None.		
<u>MATERIALS/PARTS (P/N)</u>		
Tape, thread sealing Item 32, Appendix C. Solution, soap Item 28, Appendix C.		
<u>PERSONNEL REQUIRED</u>	<u>SPECIAL ENVIRONMENTAL CONDITIONS</u>	
One (MOS-63S).	None.	
<u>REFERENCES (TM)</u>	<u>GENERAL SAFETY INSTRUCTIONS</u>	
TM 9-2320-283-10.	Engine off. Transmission in neutral. Park brake set.	
<u>TROUBLESHOOTING REFERENCES</u>		
Paragraph 2-11.		



**BRAKE SYSTEM.**

**3-181. FRONT AXLE RATIO VALVE REPLACEMENT (Continued).**

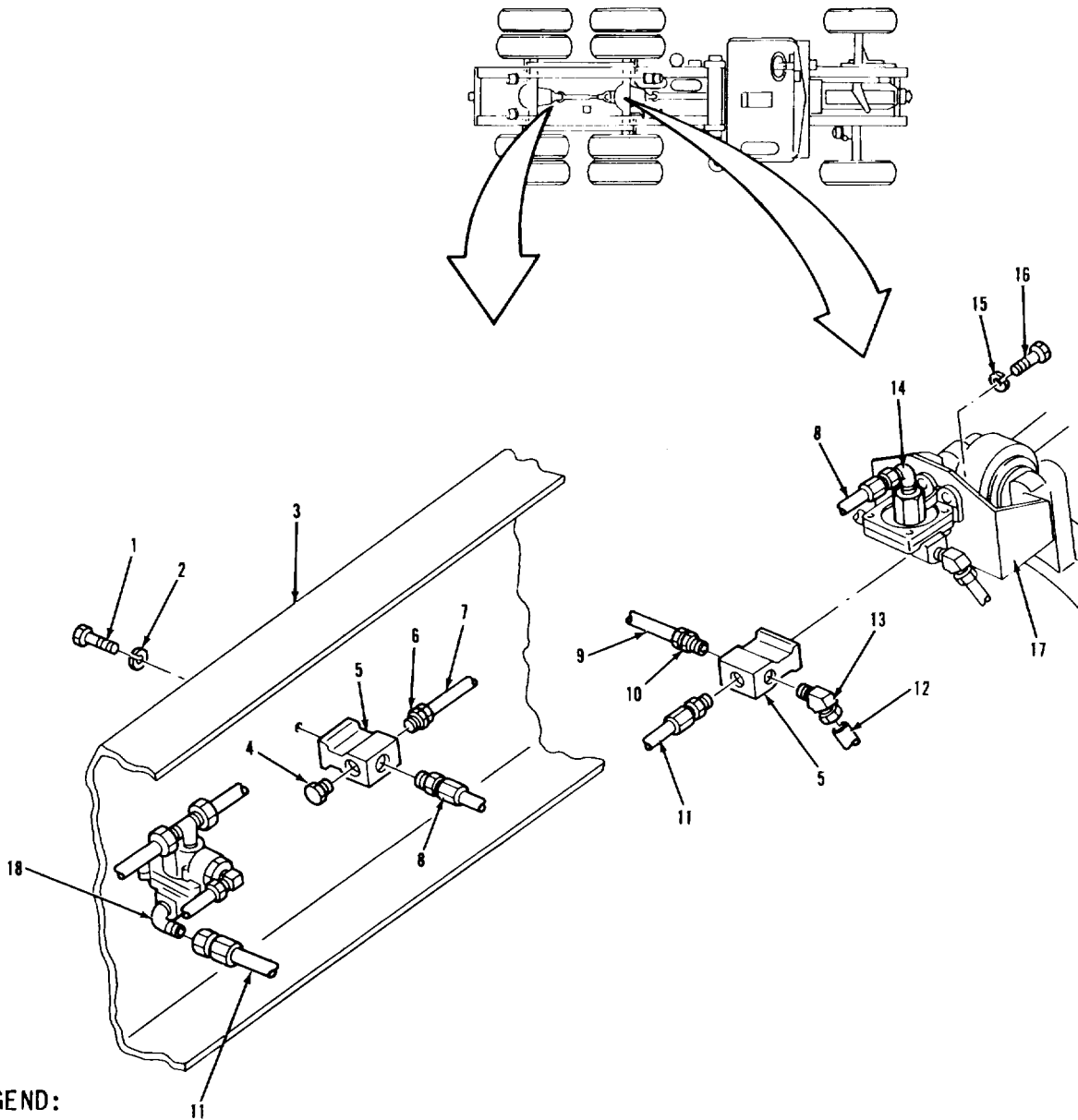

**LEGEND:**

- |                         |                            |
|-------------------------|----------------------------|
| 1. CAPSCREW             | 10. CONNECTOR              |
| 2. LOCKWASHER           | 11. AIR HOSE ASSEMBLY      |
| 3. RIGHT-HAND MAIN RAIL | 12. NONMETALLIC TUBE       |
| 4. PLUG                 | 13. ELBOW                  |
| 5. MOUNTABLE TEE        | 14. ELBOW                  |
| 6. CONNECTOR            | 15. LOCKWASHER             |
| 7. NONMETALLIC TUBE     | 16. CAPSCREW               |
| 8. BRAKE HOSE ASSEMBLY  | 17. VALVE MOUNTING BRACKET |
| 9. NONMETALLIC TUBE     | 18. ELBOW                  |

TA 237500

**BRAKE SYSTEM.**

3-181. FRONT AXLE RATIO VALVE REPLACEMENT (Continued).		
LOCATION/ITEM	ACTION	REMARKS
<b>WARNING</b>		
Never work on air system components without first draining air pressure. Failure to follow this precaution can result in serious personal injury.		
<b><u>A. REMOVAL.</u></b>		
1. Tube (6)	Remove from item (2)	Tag for identification.
2. Tube (4)	Remove from item (5)	Tag for identification.
3. Tube (3)	Remove from item (2)	Tag for identification.
4. Two screws (1), washers (10), and nuts (11).	Remove from item (8).	
5. Valve (8)	Remove from item (9).	
6. Elbow (2)	Remove from item (7)	Tag for identification.
7. Connector (5)	Remove from item (7)	Tag for identification.
8. Tee (7)	Remove from item (8)	Tag for identification.
9. Elbow (2)	Remove from item (8)	Tag for identification.
<b><u>B. CLEANING AND INSPECTION.</u></b>		
10. All metal parts	Clean and inspect	Refer to paragraphs 3-4 and 3-5.
<b><u>C. INSTALLATION.</u></b>		
11. Elbow (2)	a. Wrap threads with thread sealing tape. b. Install on item (8).	Refer to paragraph 3-7.
<b>3-1074</b>		

**BRAKE SYSTEM.**

**3-181. FRONT AXLE RATIO VALVE REPLACEMENT (Continued).**

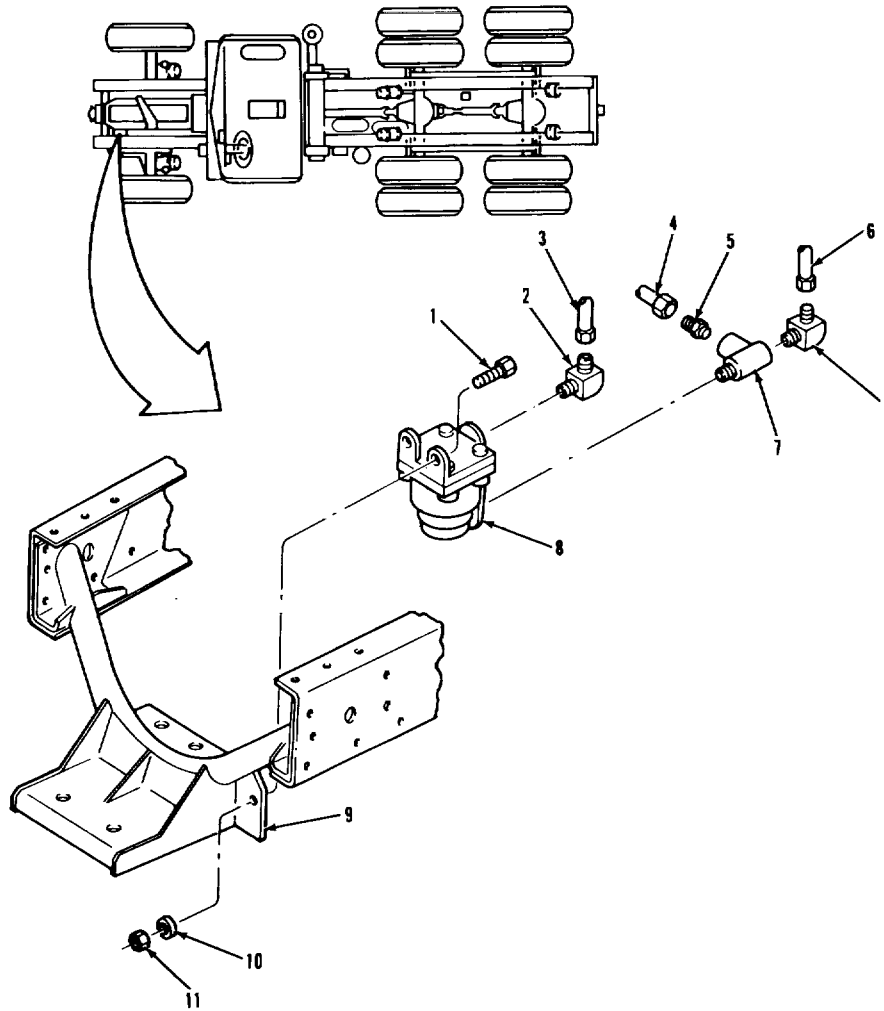

**LEGEND:**

- |                     |                               |
|---------------------|-------------------------------|
| 1. SCREW (2)        | 7. TEE                        |
| 2. ELBOW (2)        | 8. FRONT AXLE RATIO VALVE     |
| 3. NONMETALLIC TUBE | 9. FRONT CROSSMEMBER ASSEMBLY |
| 4. NONMETALLIC TUBE | 10. FLAT WASHER (2)           |
| 5. CONNECTOR        | 11. HEXAGON HEAD NUT (2)      |
| 6. NONMETALLIC TUBE |                               |

TA 237501

**BRAKE SYSTEM.**

3-181. FRONT AXLE RATIO VALVE REPLACEMENT (Continued).		
LOCATION/ITEM	ACTION	REMARKS
<b>C. INSTALLATION (Continued).</b>		
12. Tee (7)	a. Wrap threads with thread sealing tape. b. Install on item (8)	Refer to paragraph 3-7.
13. Connector (5)	a. Wrap threads with thread sealing tape. b. Install on item (7)	Refer to paragraph 3-7.
14. Elbow (2)	a. Wrap threads with thread sealing tape. b. Install on item (7)	Refer to paragraph 3-7.
15. Valve (8)	a. Line up holes in item (8) with holes in item (9). b. Secure with two items (1), (10), and (11).	
16. Tube (3)	Install on item (2).	
17. Tube (4)	Install on item (5).	
18. Tube (6)	Install on item (2).	
<b>NOTE</b>		
Follow-on maintenance action required: Close air system draincocks and start engine (TM 9-2320-283-10). Check air system for leaks (para 3-8).		
<b>3-1076</b>		

**BRAKE SYSTEM.**

**3-181. FRONT AXLE RATIO VALVE REPLACEMENT (Continued).**

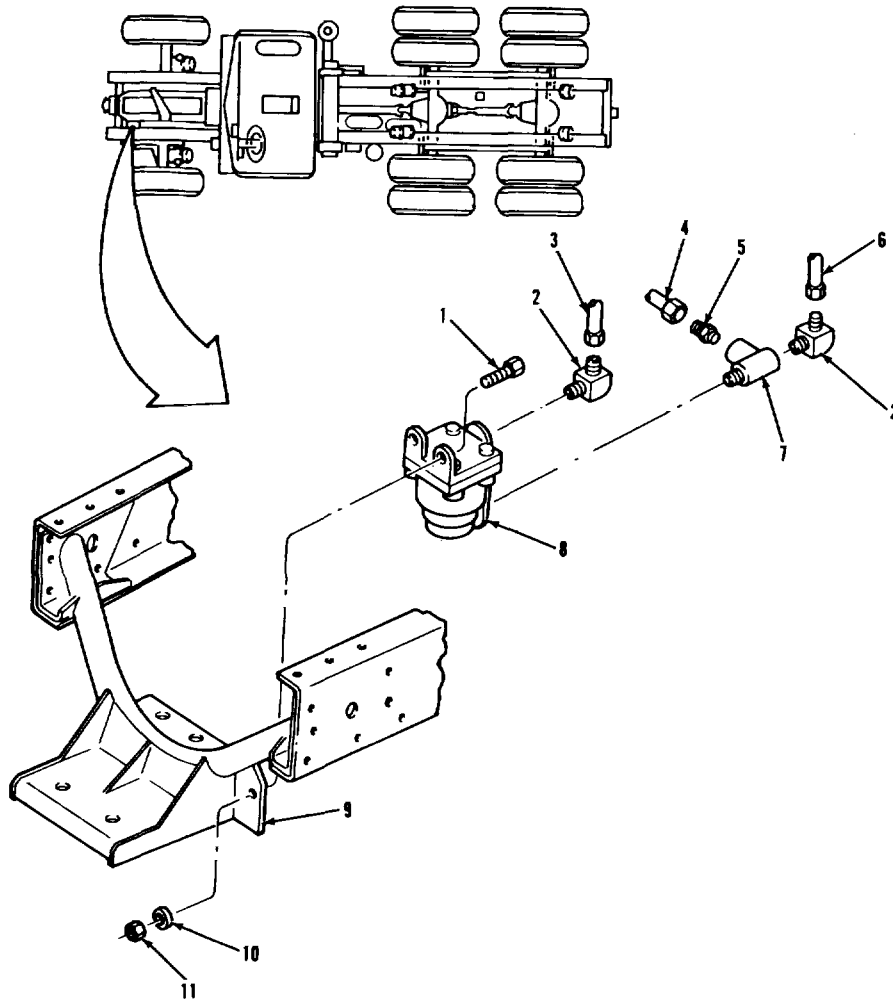

**LEGEND:**

- |                     |                               |
|---------------------|-------------------------------|
| 1. SCREW (2)        | 7. TEE                        |
| 2. ELBOW (2)        | 8. FRONT AXLE RATIO VALVE     |
| 3. NONMETALLIC TUBE | 9. FRONT CROSSMEMBER ASSEMBLY |
| 4. NONMETALLIC TUBE | 10. FLAT WASHER (2)           |
| 5. CONNECTOR        | 11. HEXAGON HEAD NUT (2)      |
| 6. NONMETALLIC TUBE |                               |

TA 237502

**BRAKE SYSTEM.**

**3-182. DOUBLE CHECK AND QUICK RELEASE VALVE REPLACEMENT.**

**This task covers:**

- a. Removal
- b. Cleaning
- c. Installation

**INITIAL SETUP:**

<u>APPLICABLE CONFIGURATIONS</u>	<u>EQUIPMENT CONDITION PARAGRAPH</u>	<u>CONDITION DESCRIPTION</u>
All.	TM 9-2320-283-10.	Air system draincocks opened.
<b><u>TEST EQUIPMENT</u></b> None.		
<b><u>SPECIAL TOOLS</u></b> None.		
<b><u>MATERIALS/PARTS CP/N)</u></b> Tape, thread sealing Item 32, Appendix C. Solution, soap Item 28, Appendix C.		
<b><u>PERSONNEL REQUIRED</u></b> One (MOS-63S).	<b><u>SPECIAL ENVIRONMENTAL CONDITIONS</u></b> None.	
<b><u>REFERENCES (TM)</u></b> TM 9-2320-283-10.	<b><u>GENERAL SAFETY INSTRUCTIONS</u></b> Engine off. Transmission in neutral. Park brake set.	
<b><u>TROUBLESHOOTING REFERENCES</u></b> Paragraph 2-11.		

**BRAKE SYSTEM.**

**3-182. DOUBLE CHECK AND QUICK RELEASE VALVE REPLACEMENT (Continued).**

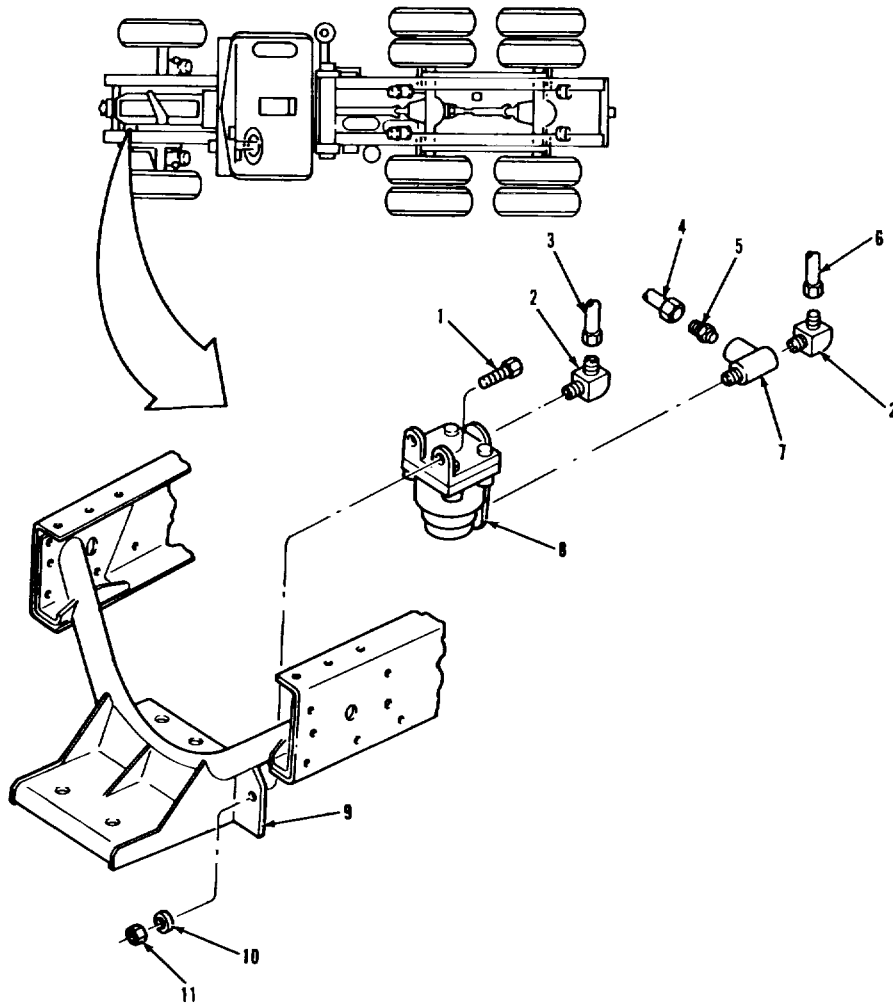

**LEGEND:**

- |                     |                               |
|---------------------|-------------------------------|
| 1. SCREW (2)        | 7. TEE                        |
| 2. ELBOW (2)        | 8. FRONT AXLE RATIO VALVE     |
| 3. NONMETALLIC TUBE | 9. FRONT CROSSMEMBER ASSEMBLY |
| 4. NONMETALLIC TUBE | 10. FLAT WASHER (2)           |
| 5. CONNECTOR        | 11. HEXAGON HEAD NUT (2)      |
| 6. NONMETALLIC TUBE |                               |

TA 237503

**BRAKE SYSTEM.**

**3-182. DOUBLE CHECK AND QUICK RELEASE VALVE REPLACEMENT (Continued).**

LOCATION/ITEM	ACTION	REMARKS
---------------	--------	---------

**WARNING**

Never work on air system components without first draining air pressure. Failure to follow this precaution can result in serious personal injury.

**A. REMOVAL.**

1. Tube (3).	Remove from item (4).	Tag for identification.
2. Tube (5).	Remove from item (4).	Tag for identification.
3. Tube (8).	Remove from item (7).	Tag for identification.
4. Hose (9).	Remove from item (10).	Tag for identification.
5. Tee (4).	Remove from item (13).	Tag for identification.
6. Plug (6).	Remove from item (13).	Tag for identification.
7. Elbow (7).	Remove from item (13).	Tag for identification.
8. Elbow (10).	Remove from item (13).	Tag for identification.
9. Two bolts (2), washers (12), and nuts (11).	a. Remove from item (13).	Tag for identification.
	b. Remove item (13) from item (1).	

**B. CLEANING AND INSPECTION.**

10. All metal parts.	Clean and inspect.	Refer to paragraphs 3-4 and 3-5.
----------------------	--------------------	----------------------------------

**3-1080**



**BRAKE SYSTEM.**

**3-182. DOUBLE CHECK AND QUICK RELEASE VALVE REPLACEMENT (Continued).**

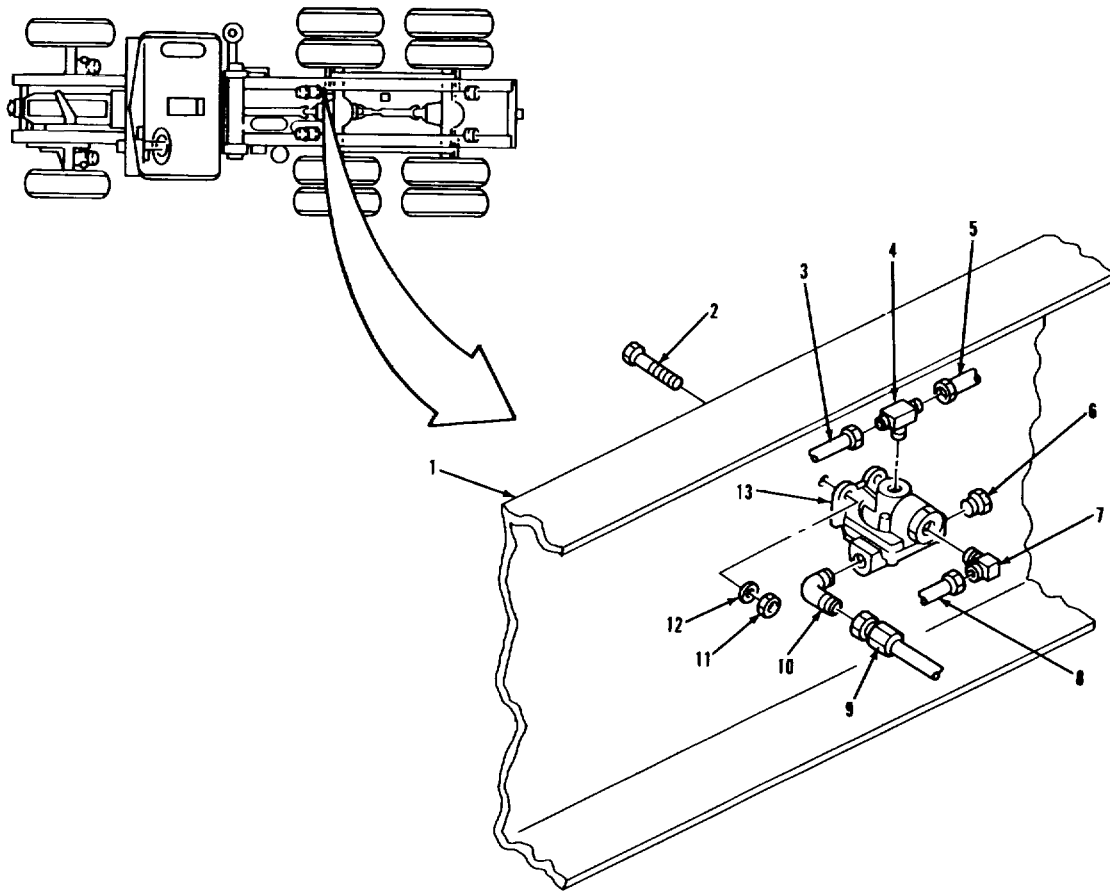

**LEGEND:**

- 1. RIGHT-HAND MAIN RAIL
- 2. HEXAGON BOLT (2)
- 3. NONMETALLIC TUBE
- 4. TEE
- 5. NONMETALLIC TUBE
- 6. PLUG
- 7. ELBOW

- 8. NONMETALLIC TUBE
- 9. AIR HOSE ASSEMBLY
- 10. ELBOW
- 11. HEXAGON HEAD NUT (2)
- 12. FLAT WASHER (2)
- 13. VALVE ASSEMBLY

TA 237504

**BRAKE SYSTEM.**

**~~3-182. DOUBLE CHECK AND QUICK RELEASE VALVE REPLACEMENT (Continued).~~**

LOCATION/ITEM	ACTION	REMARKS
<b><u>C. INSTALLATION.</u></b>		
11. Valve (13)	a. Line up holes in item (13) with holes in item (1). b. Secure with two items (2), (11), and (12).	
12. Elbow (10)	a. Wrap threads with thread sealing tape. b. Install on item (13).	Refer to paragraph 3-7.
13. Elbow (7)	a. Wrap threads with thread sealing tape. b. Install on item (13).	Refer to paragraph 3-7.
14. Plug (6)	a. Wrap threads with thread sealing tape. b. Install on item (13).	Refer to paragraph 3-7.
15. Tee (4)	a. Wrap threads with thread sealing tape. b. Install on item (13).	Refer to paragraph 3-7.
16. Hose (9)	Install on item (13).	
17. Tube (8)	Install on item (10).	
18. Tube (5)	Install on item (7).	
19. Tube (3)	Install on item (4).	
<b>NOTE</b>		
Follow-on maintenance action required: Close air system draincocks and start engine (TM 9-2320-283-10). Check air system for leaks (para 3-8).		
<b>3-1082</b>		

**BRAKE SYSTEM.**

**3-182. DOUBLE CHECK AND QUICK RELEASE VALVE REPLACEMENT (Continued).**

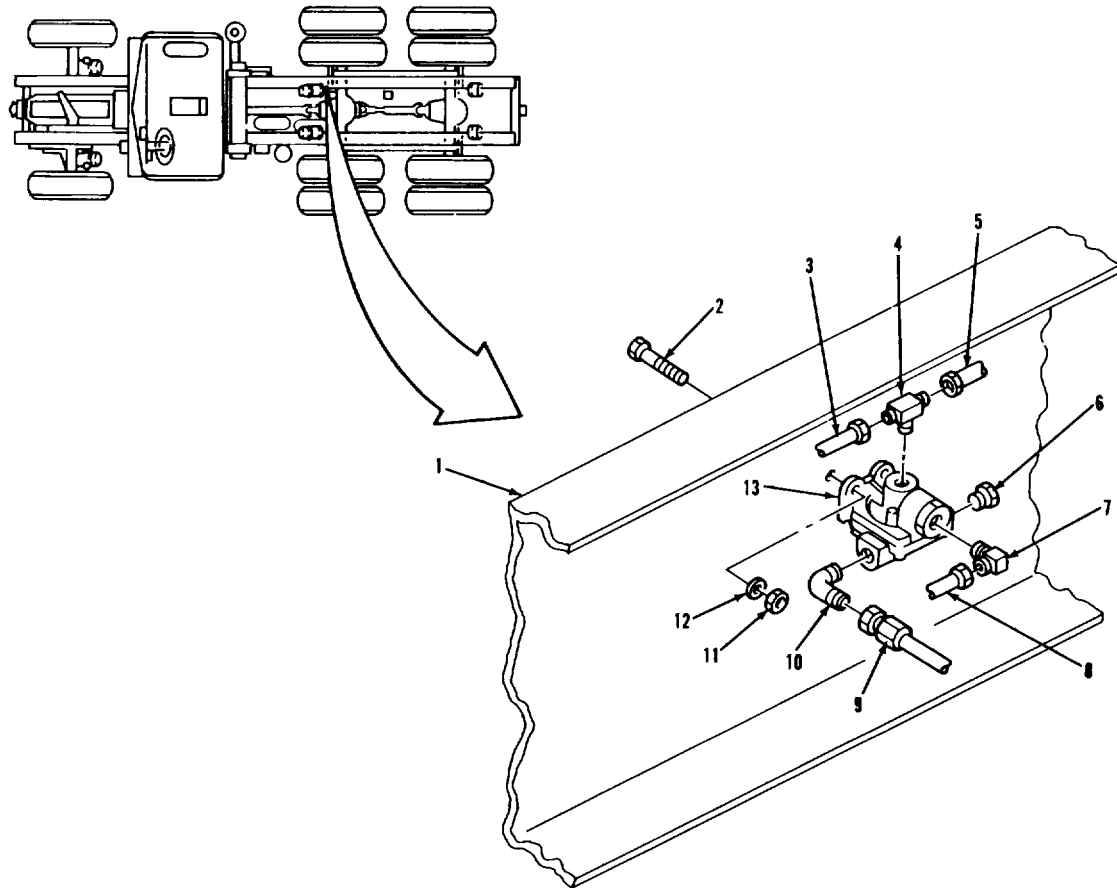

**LEGEND:**

- 1. RIGHT-HAND MAIN RAIL
- 2. HEXAGON BOLT (2)
- 3. NONMETALLIC TUBE
- 4. TEE
- 5. NONMETALLIC TUBE
- 6. PLUG
- 7. ELBOW

- 8. NONMETALLIC TUBE
- 9. AIR HOSE ASSEMBLY
- 10. ELBOW
- 11. HEXAGON HEAD NUT (2)
- 12. FLAT WASHER (2)
- 13. VALVE ASSEMBLY

TA 237505

**BRAKE SYSTEM.**

**3-183. DOUBLE CHECK AND STOPLAMP VALVE REPLACEMENT.**

**This task covers:**

- a. Removal
- b. Cleaning
- c. Installation

**INITIAL SETUP:**

<u>APPLICABLE CONFIGURATIONS</u>	<u>EQUIPMENT CONDITION PARAGRAPH</u>	<u>CONDITION DESCRIPTION</u>
All opened.	TM 9-2320-283-10	Air system draincocks
<u>TEST EQUIPMENT</u> None	3-120	Battery power disconnected.
<u>SPECIAL TOOLS</u> None.		
<u>MATERIALS/PARTS (P/N)</u> Tape, thread sealing Item 32, Appendix C. Solution, soap Item 28, Appendix C.		
<u>PERSONNEL REQUIRED</u> One (MOS-63S )	<u>SPECIAL ENVIRONMENTAL CONDITIONS</u> None.	
<u>REFERENCES (TM)</u> TM 9-2320-283-10	<u>GENERAL SAFETY INSTRUCTIONS</u> Engine off. Transmission in neutral. Park brake set.	
<u>TROUBLESHOOTING REFERENCES</u> Paragraph 2-11.		

**BRAKE SYSTEM.**

**3-183. DOUBLE CHECK AND STOPLAMP VALVE REPLACEMENT (Continued).**

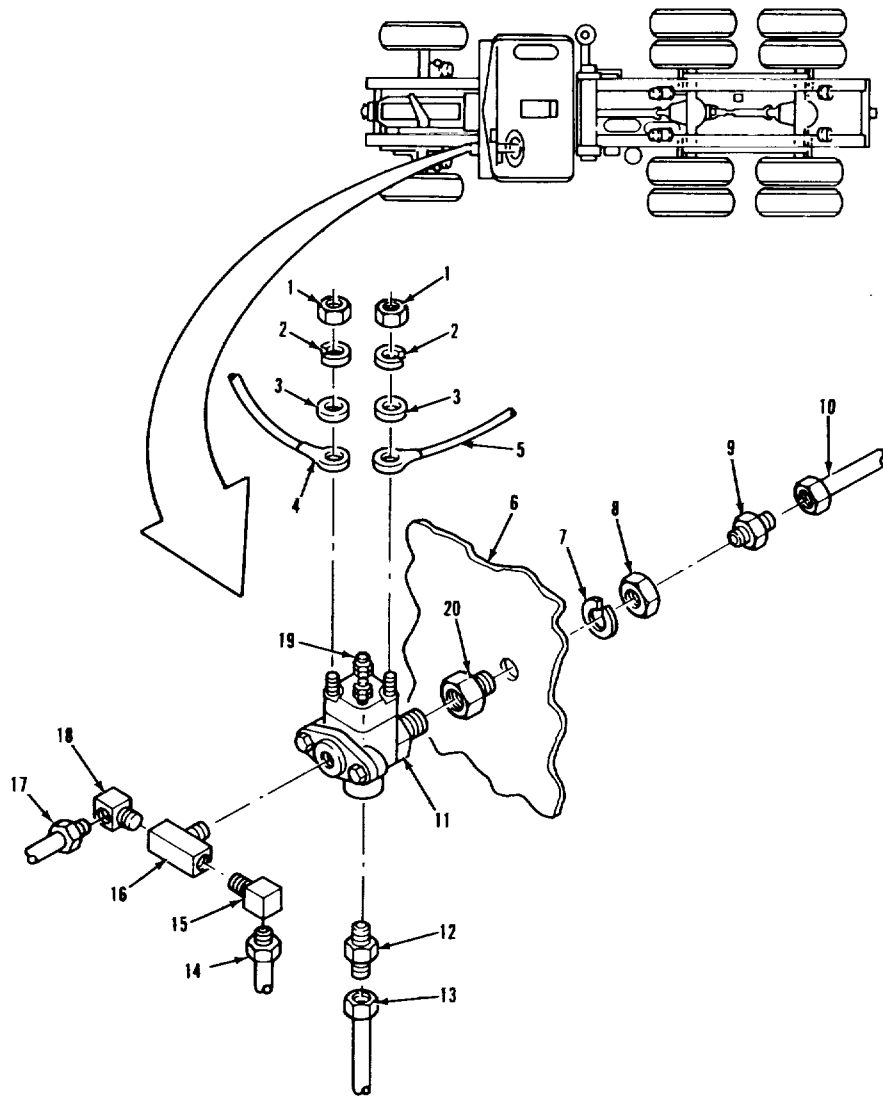

**LEGEND:**

- |                      |                      |
|----------------------|----------------------|
| 1. NUT (2)           | 11. VALVE ASSEMBLY   |
| 2. LOCKWASHER (2)    | 12. CONNECTOR        |
| 3. FLAT WASHER (2)   | 13. NONMETALLIC TUBE |
| 4. WIRE (25A)        | 14. NONMETALLIC TUBE |
| 5. WIRE (25B)        | 15. ELBOW            |
| 6. CAB (FIREWALL)    | 16. TEE              |
| 7. LOCKWASHER        | 17. NONMETALLIC TUBE |
| 8. HEXAGON PLAIN NUT | 18. ELBOW            |
| 9. CONNECTOR         | 19. TERMINAL (2)     |
| 10. NONMETALLIC TUBE | 20. BULKHEAD UNION   |

TA 237507

**BRAKE SYSTEM.**

<b>3-183. DOUBLE CHECK AND STOPLAMP VALVE REPLACEMENT (Continued).</b>		
<b>LOCATION/ITEM</b>	<b>ACTION</b>	<b>REMARKS</b>
<b>WARNING</b>		
Never work on air system components without first draining air pressure. Failure to follow this precaution can result in serious personal injury.		
<b>A. REMOVAL.</b>		
1. Tube (14)	Remove from item (15)	Tag for identification.
2. Tube (17)	Remove from item (18)	Tag for identification.
3. Elbow (15) and (18).	Remove from item (16)	Tag for identification.
4. Tee (16)	Remove from item (11)	Tag for identification.
5. Tube (13)	Remove from item (12)	Tag for identification.
6. Connector (12)	Remove from item (11)	Tag for identification.
7. Two nuts (1), lockwashers (2), and washers (3).	a. Remove from two items (19).	
	b. Remove item (4) and (5) from item (19).	Tag for identification.
8. Valve (11)	Remove from item (20)	Position with two items (19) straight up.
<b>NOTE</b>		
Do the following steps if replacing bulkhead union; otherwise, go to cleaning and inspection.		
9. Tube (10)	Remove from item (9)	Tag for identification.
<b>3-1086</b>		

**BRAKE SYSTEM.**

**3-183. DOUBLE CHECK AND STOPLAMP VALVE REPLACEMENT (Continued).**

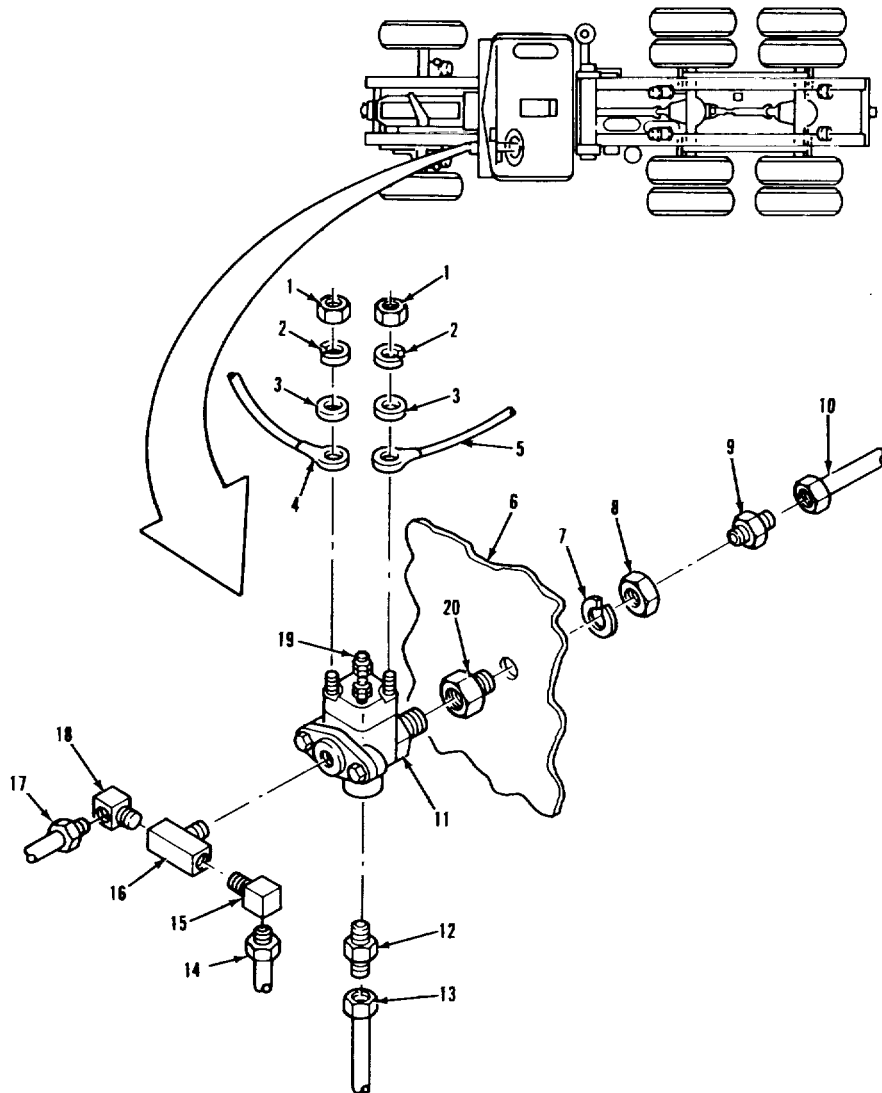

**LEGEND:**

- |                      |                      |
|----------------------|----------------------|
| 1. NUT (2)           | 11. VALVE ASSEMBLY   |
| 2. LOCKWASHER (2)    | 12. CONNECTOR        |
| 3. FLAT WASHER (2)   | 13. NONMETALLIC TUBE |
| 4. WIRE (25A)        | 14. NONMETALLIC TUBE |
| 5. WIRE (25B)        | 15. ELBOW            |
| 6. CAB (FIREWALL)    | 16. TEE              |
| 7. LOCKWASHER        | 17. NONMETALLIC TUBE |
| 8. HEXAGON PLAIN NUT | 18. ELBOW            |
| 9. CONNECTOR         | 19. TERMINAL (2)     |
| 10. NONMETALLIC TUBE | 20. BULKHEAD UNION   |

TA 237507

**BRAKE SYSTEM.**

<b>3-183. DOUBLE CHECK AND STOPLAMP VALVE REPLACEMENT (Continued).</b>		
<b>LOCATION/ITEM</b>	<b>ACTION</b>	<b>REMARKS</b>
<b><u>A. REMOVAL (Continued).</u></b>		
10 Connector (9)	Remove from item (20).	
11 Nut (8) and lock-washer (7)	a Remove from item (20) b Remove item (20) from item (6).	Assistant helps remove item (20).
<b><u>B. CLEANING AND INSPECTION.</u></b>		
12 All metal parts	Clean and inspect	Refer to paragraphs 3-4 and 3-5.
<b><u>C. INSTALLATION.</u></b>		
<b>NOTE</b>		
Do steps 13 thru 15 if bulkhead connector was replaced; otherwise, begin with step 16.		
13 Connector (20)	a Place in opening in item (6). b Secure with items (7) and (8).	
14 Connector (9)	a Wrap threads with thread sealing tape. b Install in item (20).	Refer to paragraph 3-7.
15 Tube (10)	Install on item (9).	
16 Valve (11)	a Wrap threads with thread sealing tape. b Install on item (20)	Refer to paragraph 3-7. Items (19) face up.
<b>3-1088</b>		



**BRAKE SYSTEM.**

**3-183. DOUBLE CHECK AND STOPLAMP VALVE REPLACEMENT (Continued).**

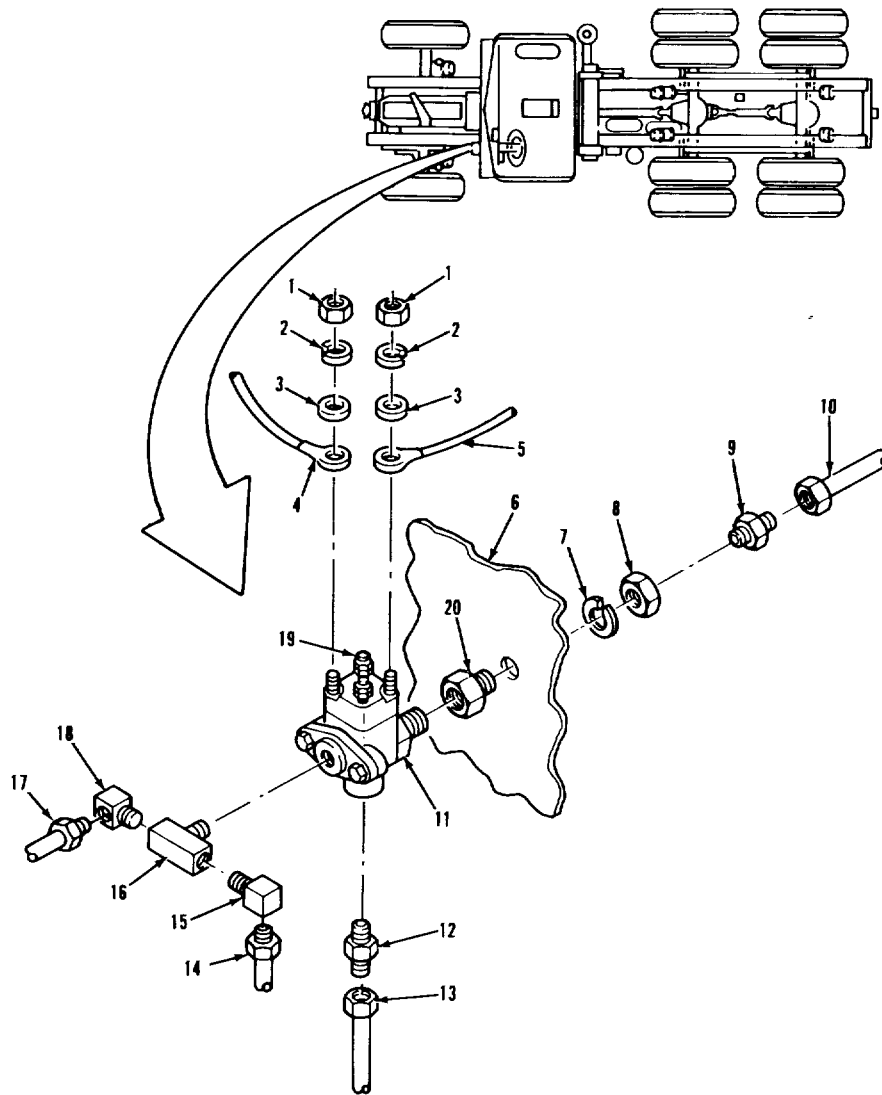

**LEGEND:**

- |                      |                      |
|----------------------|----------------------|
| 1. NUT (2)           | 11. VALVE ASSEMBLY   |
| 2. LOCKWASHER (2)    | 12. CONNECTOR        |
| 3. FLAT WASHER (2)   | 13. NONMETALLIC TUBE |
| 4. WIRE (25A)        | 14. NONMETALLIC TUBE |
| 5. WIRE (25B)        | 15. ELBOW            |
| 6. CAB (FIREWALL)    | 16. TEE              |
| 7. LOCKWASHER        | 17. NONMETALLIC TUBE |
| 8. HEXAGON PLAIN NUT | 18. ELBOW            |
| 9. CONNECTOR         | 19. TERMINAL (2)     |
| 10. NONMETALLIC TUBE | 20. BULKHEAD UNION   |

TA 237508

**BRAKE SYSTEM.**

<b>3-183. DOUBLE CHECK AND STOPLAMP VALVE REPLACEMENT (Continued).</b>		
<b>LOCATION/ITEM</b>	<b>ACTION</b>	<b>REMARKS</b>
<b><u>C. INSTALLATION (Continued).</u></b>		
17. Wires (4) and (5).	a. Place on item (19). b. Secure with two items (1), (2), and (3).	
18. Connector (12)	a. Wrap threads with thread sealing tape. b. Install on item (11). Install on item (12).	Refer to paragraph 3-7.
19. Tube (13)		
20. Tee (16)	a. Wrap threads with thread sealing tape. b. Install on item (11).	Refer to paragraph 3-7.
21. Elbow (15) and (18)	a. Wrap threads with thread sealing tape. b. Install on item (16). Install on item (18).	Refer to paragraph 3-7.
22. Tube (17)		
23. Tube (14)	Install on item (15).	
<b>NOTE</b>		
Follow-on maintenance action required: Close air system draincocks and start engine (TM 9-2320-283-10). Check air system for leaks (para 3-8).		
<b>3-1090</b>		

**BRAKE SYSTEM.**

**3-183. DOUBLE CHECK AND STOPLAMP VALVE REPLACEMENT (Continued).**

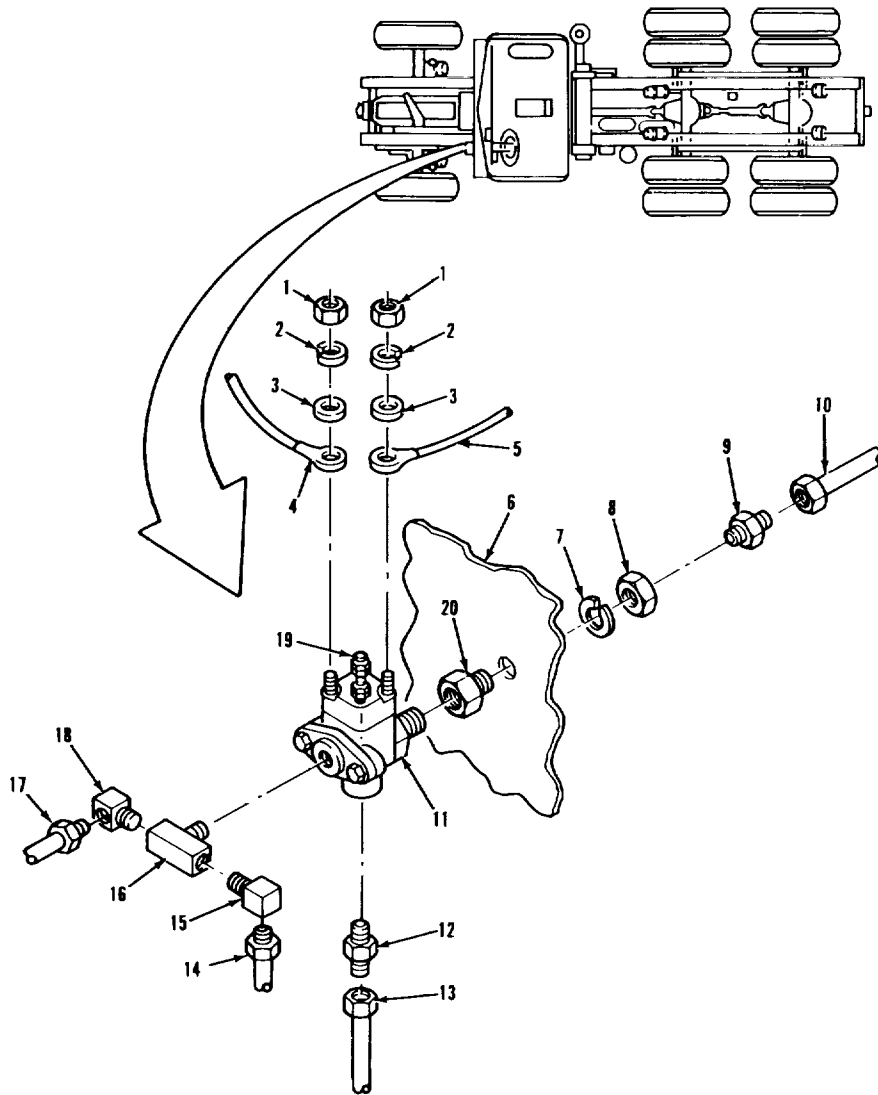

**LEGEND:**

- |                      |                      |
|----------------------|----------------------|
| 1. NUT (2)           | 11. VALVE ASSEMBLY   |
| 2. LOCKWASHER (2)    | 12. CONNECTOR        |
| 3. FLAT WASHER (2)   | 13. NONMETALLIC TUBE |
| 4. WIRE (25A)        | 14. NONMETALLIC TUBE |
| 5. WIRE (25B)        | 15. ELBOW            |
| 6. CAB (FIREWALL)    | 16. TEE              |
| 7. LOCKWASHER        | 17. NONMETALLIC TUBE |
| 8. HEXAGON PLAIN NUT | 18. ELBOW            |
| 9. CONNECTOR         | 19. TERMINAL (2)     |
| 10. NONMETALLIC TUBE | 20. BULKHEAD UNION   |

TA 237509

**BRAKE SYSTEM.**

**3-184. FIREWALL DOUBLE CHECK VALVE REPLACEMENT.**

**This task covers:**

- a. Removal
- b. Cleaning
- c. Installation

**INITIAL SETUP:**

<u>APPLICABLE CONFIGURATIONS</u>	<u>EQUIPMENT CONDITION PARAGRAPH</u>	<u>CONDITION DESCRIPTION</u>
All	TM 9-2320-283-10	Air system draincocks opened.
<u>TEST EQUIPMENT</u> None	3-120	Battery power disconnected.
<u>SPECIAL TOOLS</u> None.		
<u>MATERIALS/PARTS (P/N)</u> Tape, thread sealing Item 32, Appendix C. Solution, soap Item 28, Appendix C.		
<u>PERSONNEL REQUIRED</u> One (MOS-63S)	<u>SPECIAL ENVIRONMENTAL CONDITIONS</u> None.	
<u>REFERENCES (TM)</u> TM 9-2320-2 3-10	<u>GENERAL SAFETY INSTRUCTIONS</u> Engine off. Transmission in neutral. Park brake set.	
<u>TROUBLESHOOTING REFERENCES</u> Paragraph 2-11.		

BRAKE SYSTEM.

3-184. FIREWALL DOUBLE CHECK VALVE REPLACEMENT (Continued).

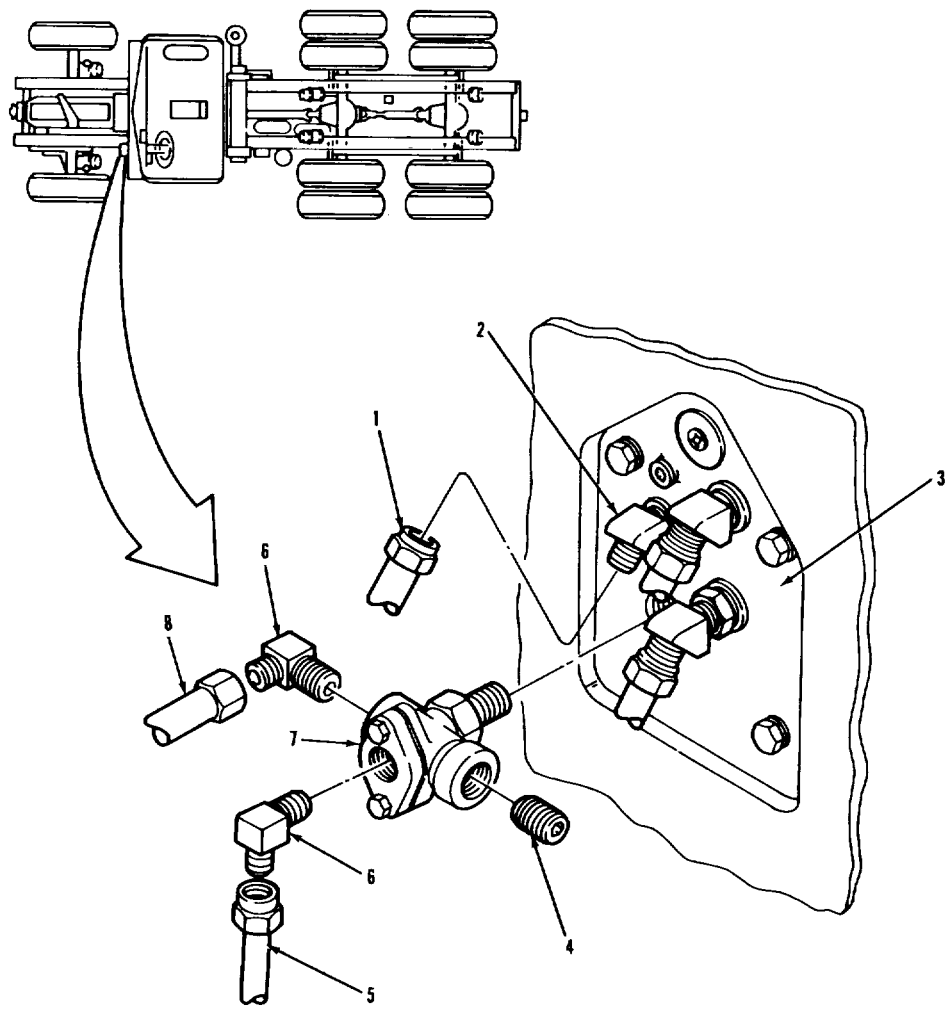

LEGEND:

- |                     |                       |
|---------------------|-----------------------|
| 1. NONMETALLIC TUBE | 5. NONMETALLIC TUBE   |
| 2. ELBOW            | 6. ELBOW (2)          |
| 3. TREADLE VALVE    | 7. DOUBLE CHECK VALVE |
| 4. PLUG             | 8. NONMETALLIC TUBE   |

TA 237511

**BRAKE SYSTEM.**

3-184. FIREWALL DOUBLE CHECK VALVE REPLACEMENT (Continued)		
LOCATION/ITEM	ACTION	REMARKS
<b><u>WARNING</u></b>		
<b>Never work on air system components without first draining air pressure. Failure to follow this precaution can result in serious personal injury.</b>		
<b><u>A. REMOVAL.</u></b>		
1. Tube (1).	Remove from item (2).	Removed for accessing. Tag for identification.
2. Tube (5).	Remove from item (6).	Tag for identification.
3. Tube (8).	Remove from item (6).	Tag for identification.
4. Two elbows (6).	Remove from item (7).	Tag for identification.
5. Plug (4).	Remove from item (7).	Tag for identification.
6. Valve (7).	Remove from item (3).	
<b><u>B. CLEANING AND INSPECTION.</u></b>		
7. All metal parts.	Clean and inspect.	Refer to paragraphs 3-4 and 3-5.
<b><u>C. INSTALLATION.</u></b>		
8. Valve (7).	a. Wrap threads with thread sealing tape.	Refer to paragraph 3-7.
	b. Install on item (3).	
9. Plug (4).	a. Wrap threads with thread sealing tape.	Refer to paragraph 3-7.
	b. Install on item (7).	
<b>3-1094</b>		

3-184. FIREWALL DOUBLE CHECK VALVE REPLACEMENT (Continued).

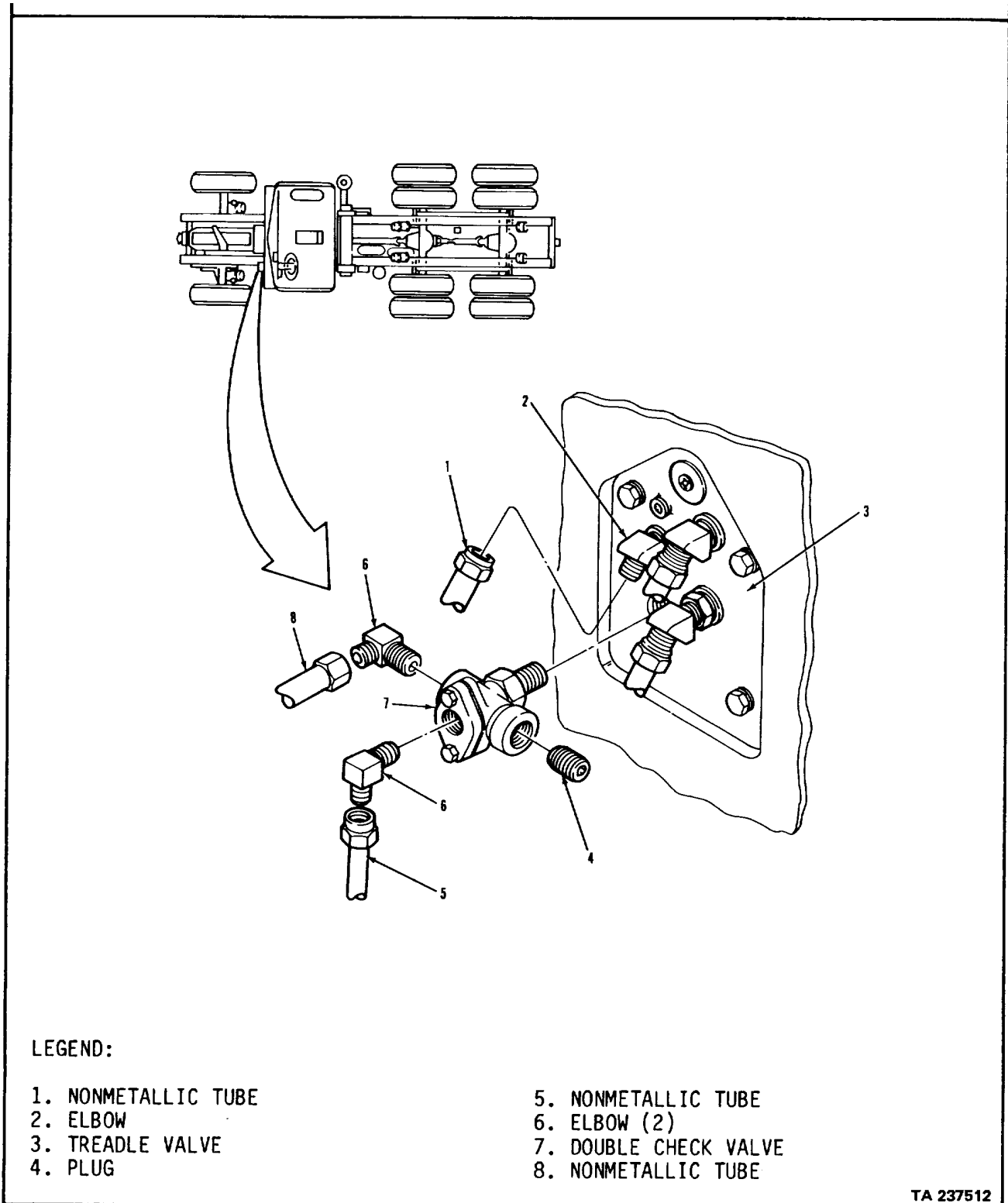

TA 237512

3-184. FIREWALL DOUBLE CHECK VALVE REPLACEMENT (Continued)		
LOCATION/ITEM	ACTION	REMARKS
<u>C. INSTALLATION (Continued).</u>		
10. Two elbows (6).	a. Wrap threads with thread sealing tape. b. Install on item (7).	Refer to paragraph 3-7.
11. Tube (8).	Install on item (6).	
12. Tube (5).	Install on item (6).	
13. Tube (1).	Install on item (2).	
<b>NOTE</b>		
<b>Follow on maintenance action required:</b>		
<b>Close air system draincocks and start engine (TM 9-2320-283-10). Check air system for leaks (para 3-8).</b>		
<b>3-1096</b>		



3-184. FIREWALL DOUBLE CHECK VALVE REPLACEMENT (Continued).

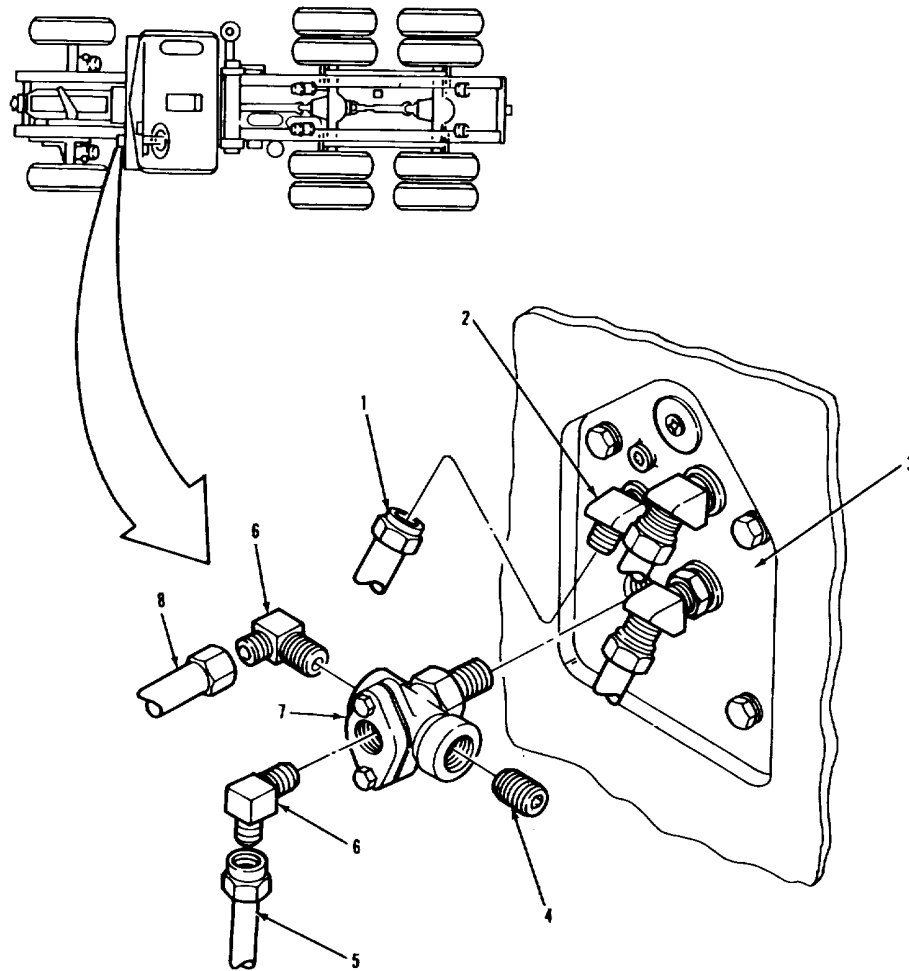

LEGEND:

- 1. NONMETALLIC TUBE
- 2. ELBOW
- 3. TREADLE VALVE
- 4. PLUG

- 5. NONMETALLIC TUBE
- 6. ELBOW (2)
- 7. DOUBLE CHECK VALVE
- 8. NONMETALLIC TUBE

TA 237513

**BRAKE SYSTEM.**

**3-185. SECONDARY RESERVOIR DOUBLE CHECK VALVE REPLACEMENT.**

---

THIS TASK COVERS

- a. Removal.
  - b. Cleaning and Inspection.
  - c. Installation.
- 

INITIAL SETUP

APPLICABLE CONFIGURATIONS

All. TM 9-2320-283-10.

EQUIPMENT CONDITION

PARAGRAPH

Air system draincocks

CONDITION DESCRIPTION

opened.

TEST EQUIPMENT

None.

SPECIAL TOOLS

None.

MATERIALS/PARTS (P/N)

Tape, thread sea ing  
Item 32, Appendix C.

PERSONNEL REQUIRED

One (MOS-63S).

SPECIAL ENVIRONMENTAL CONDITIONS

None.

REFERENCES (TM)

TM 9-2320-283-10.

GENERAL SAFETY INSTRUCTIONS

Engine off.  
Transmission in neutral.  
Park brake set.

TROUBLESHOOTING REFERENCES

Paragraph 2-11.

**3-1098**

BRAKE SYSTEM.

3-185. SECONDARY RESERVOIR DOUBLE CHECK VALVE REPLACEMENT (Continued).

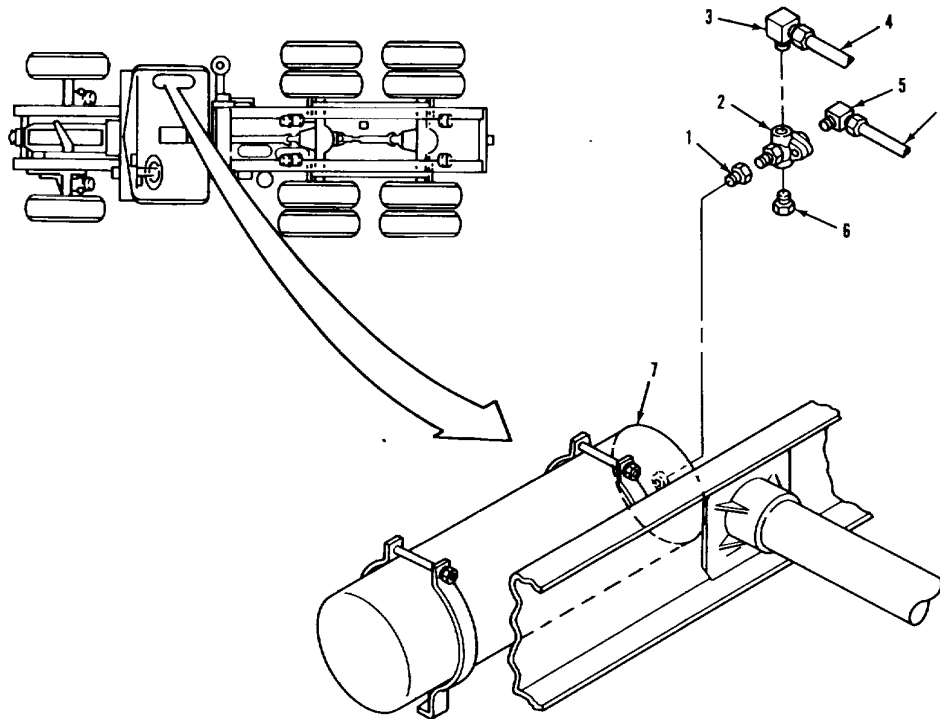

LEGEND:

- 1. REDUCER
- 2. DOUBLE CHECK VALVE
- 3. ELBOW
- 4. AIR LINE (2)

- 5. ELBOW
- 6. PLUG
- 7. SECONDARY RESERVOIR

TA 237514

**BRAKE SYSTEM.**

3-185. SECONDARY RESERVOIR DOUBLE CHECK VALVE REPLACEMENT (Continued).		
LOCATION/ITEM	ACTION	REMARKS
<b><u>WARNING</u></b>		
<b>Never work on air system components without first draining air pressure. Failure to follow this precaution can result in serious personal injury.</b>		
<b><u>A. REMOVAL.</u></b>		
1. Two air lines (4).	Remove from item (5) and item (3).	Tag.
2. Double check valve (2).	Remove from item (1).	Hold item (1) to prevent it from turning while removing item (2).
3. Elbow (3).	Remove from item (2).	
4. Elbow (5).	Remove from item (2).	
5. Plug (6).	Remove from item (2).	
<b><u>B. CLEANING AND INSPECTION.</u></b>		
6. All parts.	Clean and inspect.	Refer to paragraphs 3-4 and 3-5.
<b><u>C. INSTALLATION.</u></b>		
7. Plug (6), elbow (5), elbow (3).	Install and tighten in item (2).	Use thread sealing tape on threads.
8. Double check valve (2).	Install and tighten in item (1).	Use thread sealing tape on threads.
9. Two air lines (4).	Install and tighten in item (3) and item (5).	
<b>3-1100</b>		

**BRAKE SYSTEM.**

**3-185. SECONDARY RESERVOIR DOUBLE CHECK VALVE REPLACEMENT (Continued).**

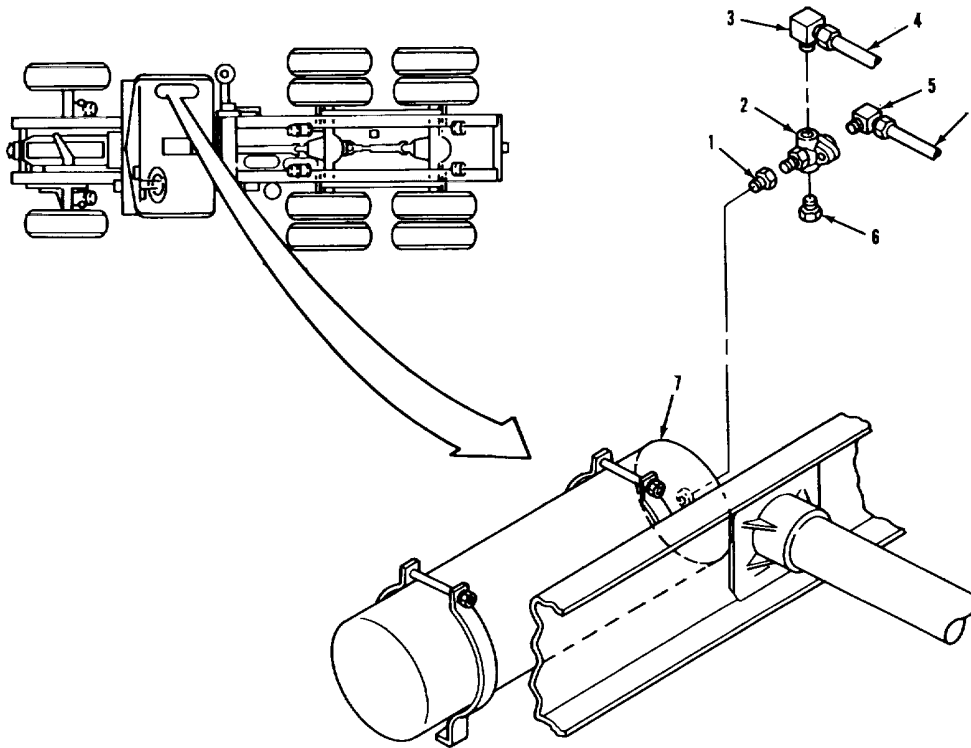

**LEGEND:**

- 1. REDUCER
- 2. DOUBLE CHECK VALVE
- 3. ELBOW
- 4. AIR LINE (2)

- 5. ELBOW
- 6. PLUG
- 7. SECONDARY RESERVOIR

TA 237515

**BRAKE SYSTEM.**

**3-185. SECONDARY RESERVOIR DOUBLE CHECK VALVE REPLACEMENT (Continued).**

LOCATION/ITEM	ACTION	REMARKS
---------------	--------	---------

C. INSTALLATION (Continued).

**NOTE**

**Follow-on maintenance action required:**

**Close air system draincocks and start engine (TM 9-2320-283-10). Check air system for leaks (para3-8).**

3-185. SECONDARY RESERVOIR DOUBLE CHECK VALVE REPLACEMENT (Continued).

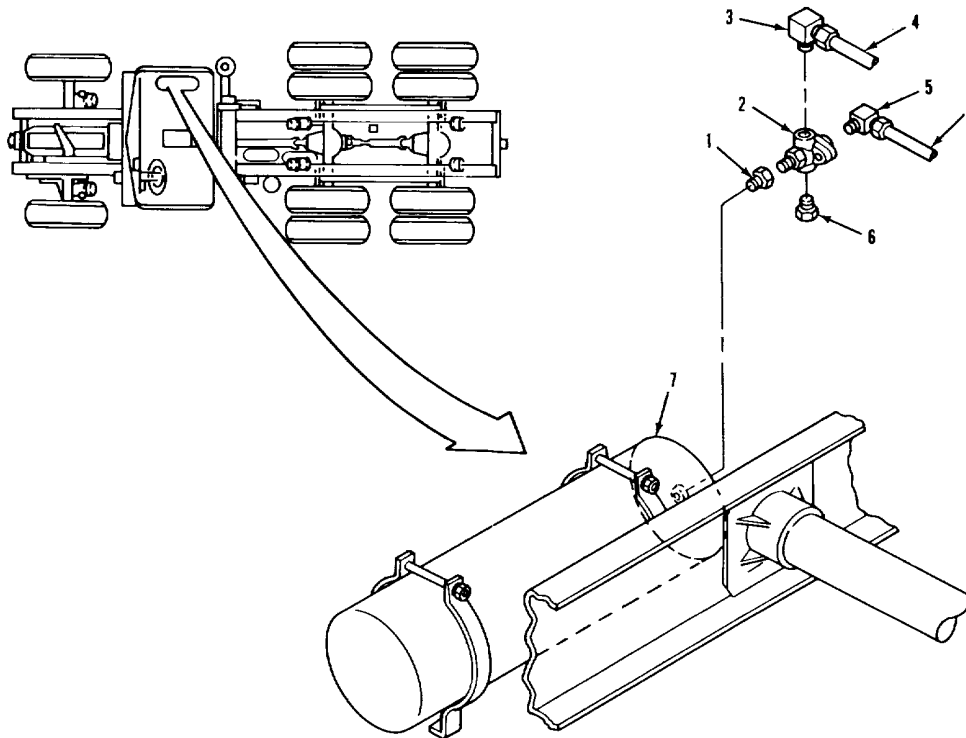

LEGEND:

- 1. REDUCER
- 2. DOUBLE CHECK VALVE
- 3. ELBOW
- 4. AIR LINE (2)

- 5. ELBOW
- 6. PLUG
- 7. SECONDARY RESERVOIR

TA 237516

**BRAKE SYSTEM.**

**3-186. SUPPLY RESERVOIR SAFETY VALVE REPLACEMENT.**

---

THIS TASK COVERS

- a. Removal.
  - b. Installation.
- 

INITIAL SETUP

APPLICABLE CONFIGURATIONS  
All. TM 9-2320-283-10.

EQUIPMENT CONDITION  
PARAGRAPH  
Air system draincocks

CONDITION DESCRIPTION  
opened.

TEST EQUIPMENT  
None.

SPECIAL TOOLS  
None.

MATERIALS/PARTS (P/N)  
Tape, thread sea ing  
Item 32, Appendix C.

PERSONNEL REQUIRED  
One (MOS-63S).

SPECIAL ENVIRONMENTAL CONDITIONS  
None.

REFERENCES (TM)  
TM 9-2320-283-10.

GENERAL SAFETY INSTRUCTIONS  
Engine off.  
Transmission in neutral.  
Park brake set.

TROUBLESHOOTING REFERENCES  
Paragraph 2-11.

**3-1104**



BRAKE SYSTEM.

3-186. SUPPLY RESERVOIR SAFETY VALVE REPLACEMENT (Continued).

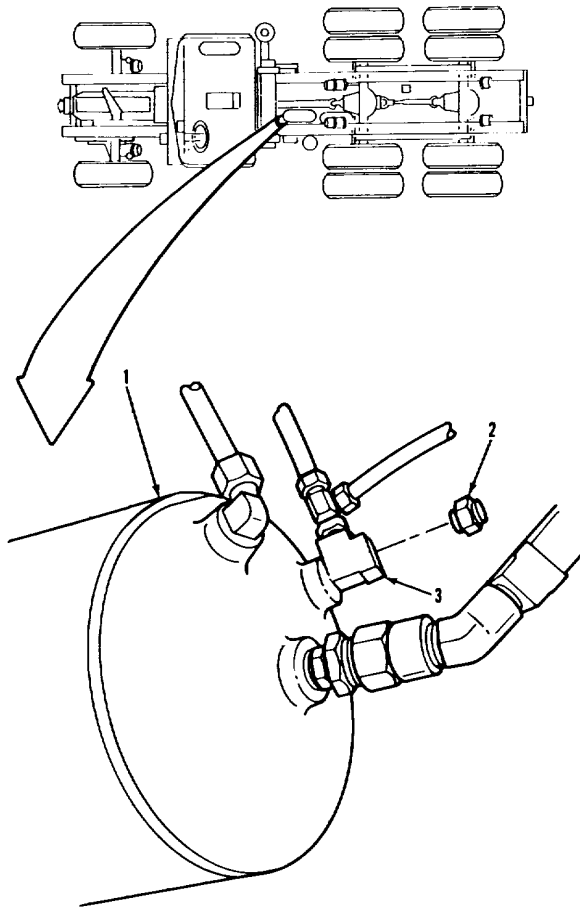

LEGEND:

- 1. SUPPLY RESERVOIR
- 2. SAFETY VALVE
- 3. MALE STREET TEE

TA 237517

BRAKE SYSTEM.

3-186. SUPPLY RESERVOIR SAFETY VALVE REPLACEMENT (Continued).		
LOCATION/ITEM	ACTION	REMARKS
<b><u>WARNING</u></b>		
<b>Never work on air system components without first draining air pressure. Failure to follow this precaution can result in serious personal injury.</b>		
<b><u>A. REMOVAL.</u></b>		
1. Safety valve (2).	Loosen and remove from item (1).	Hold item (3) with open end wrench to prevent it from turning.
<b><u>B. INSTALLATION.</u></b>		
2. Safety valve (2).	Install and tighten.	Use thread sealing tape on threads.
<b>NOTE</b>		
<b>Follow-on maintenance action required: Close air system draincocks and start engine (TM 9-2320-283-10). Check air system for leaks (para 3-8).</b>		
<b>3-1106</b>		

BRAKE SYSTEM.

3-186. SUPPLY RESERVOIR SAFETY VALVE REPLACEMENT (Continued).

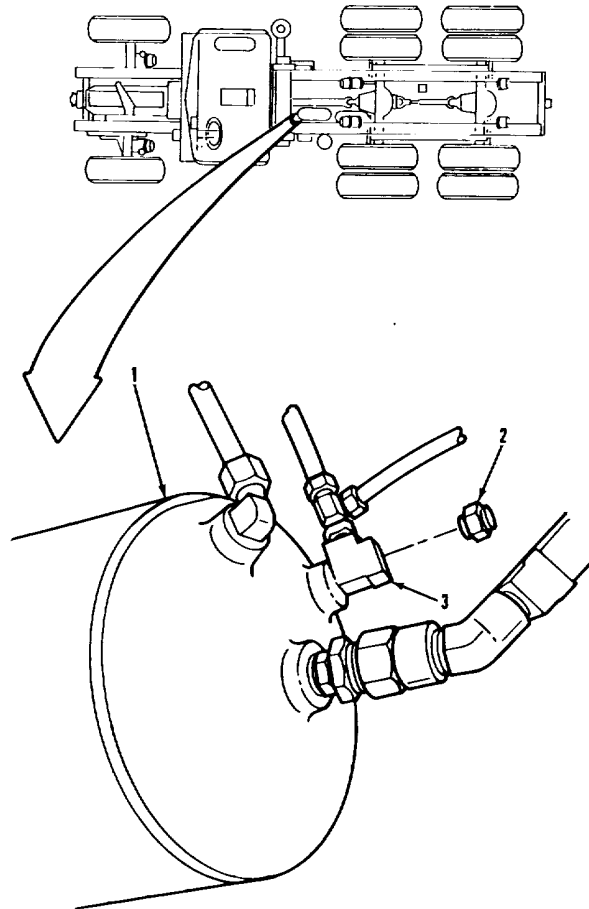

LEGEND:

- 1. SUPPLY RESERVOIR
- 2. SAFETY VALVE
- 3. MALE STREET TEE

TA 237518

**BRAKE SYSTEM.****3-187. SECONDARY RESERVOIR CHECK VALVE REPLACEMENT.**

---

THIS TASK COVERS

- a. Removal.
  - b. Installation.
- 

## INITIAL SETUP

APPLICABLE CONFIGURATIONS

All. TM 9-2320-283-10.  
open.

TEST EQUIPMENT

None.

SPECIAL TOOLS

None.

MATERIALS/PARTS (P/N)

Tape, thread sealing  
Item 32, Appendix C.

PERSONNEL REQUIRED

One (MOS-63S).

REFERENCES (TM)

TM 9-2320-283-10.

TROUBLESHOOTING REFERENCES

Paragraph 2-11.

EQUIPMENT CONDITION  
PARAGRAPH

Air system draincocks

CONDITION DESCRIPTIONSPECIAL ENVIRONMENTAL CONDITIONS

None.

GENERAL SAFETY INSTRUCTIONS

Engine off.  
Transmission in neutral.  
Park brake set.

**3-1108**

3-187. SECONDARY RESERVOIR CHECK VALVE REPLACEMENT (Continued).

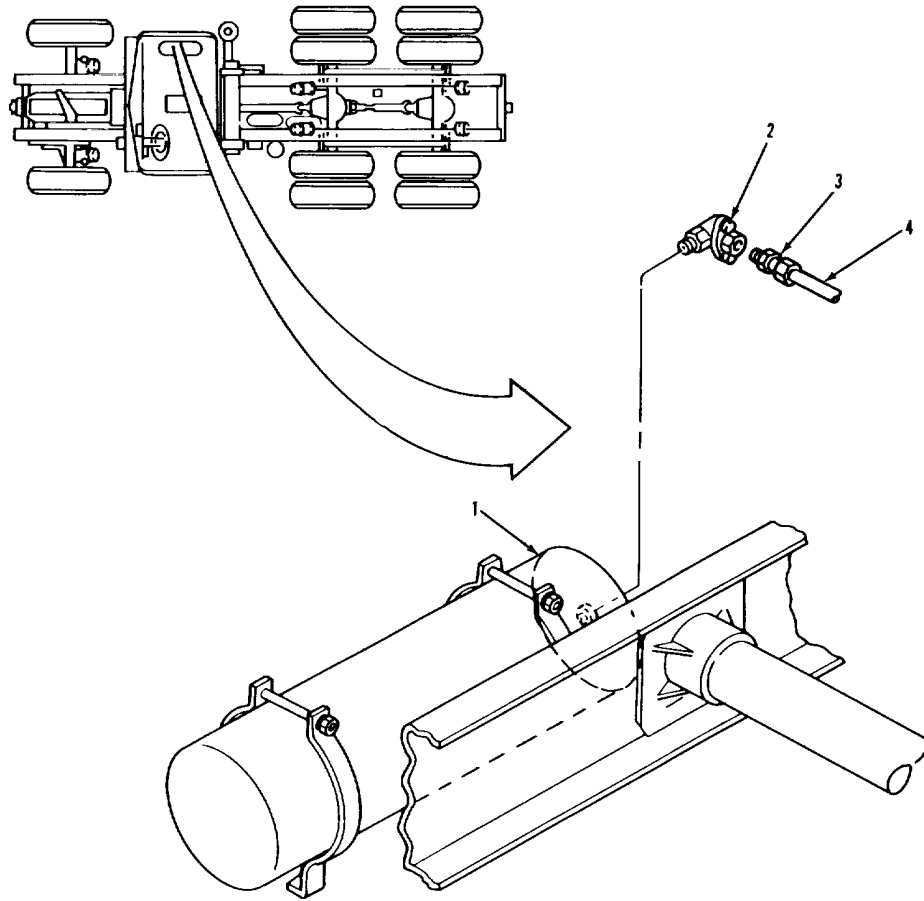

LEGEND:

- 1. SECONDARY RESERVOIR
- 2. CHECK VALVE
- 3. CONNECTOR
- 4. AIR LINE

TA 237519

BRAKE SYSTEM.

3-187. SECONDARY RESERVOIR CHECK VALVE REPLACEMENT (Continued).		
LOCATION/ITEM	ACTION	REMARKS
<b>WARNING</b>		
<b>Never work on air system components without first draining air pressure. Failure to follow this precaution can result in serious personal injury.</b>		
<u>A. REMOVAL.</u>		
1. Air line (4).	Disconnect.	Tag.
2. Connector (3).	Remove from item (2).	
3. Check valve (2).	Remove from item (1).	
<u>B. INSTALLATION.</u>		
4. Check valve (2).	Install.	Use thread sealing tape on threads.
5. Connector (3).	Install into item (2).	Use thread sealing tape on threads.
6. Air line (4).	Connect to item (3) and tighten.	
<b>NOTE</b>		
<b>Follow-on maintenance action required:</b>		
<b>Close air system draincocks and start engine (TM 9-2320-283-10). Check air system for leaks (para 3-8).</b>		
<b>3-1110</b>		

**BRAKE SYSTEM.**

**3-187. SECONDARY RESERVOIR CHECK VALVE REPLACEMENT (Continued).**

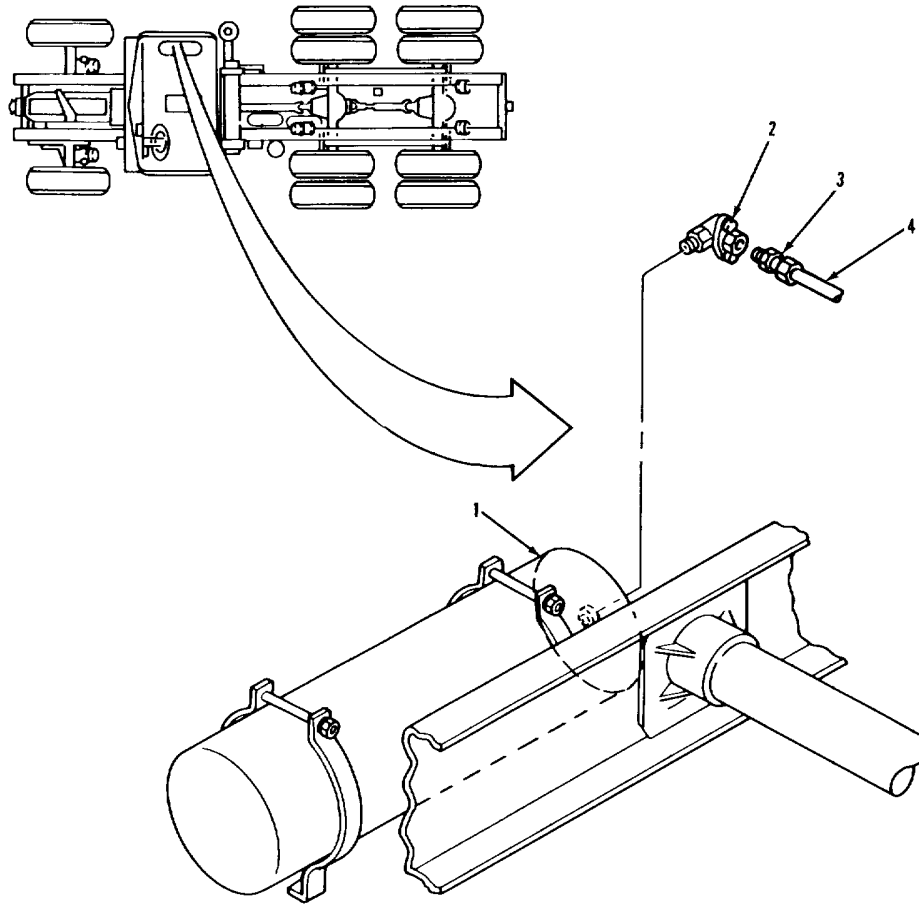

**LEGEND:**

- 1. SECONDARY RESERVOIR
- 2. CHECK VALVE
- 3. CONNECTOR
- 4. AIR LINE

TA 237520

**BRAKE SYSTEM.****3-188. PRIMARY AND SECONDARY RESERVOIR DRAINCOCK REPLACEMENT.**

---

THIS TASK COVERS

- a. Removal.
  - b. Inspection.
  - c. Installation.
- 

INITIAL SETUPAPPLICABLE CONFIGURATIONS

All. TM 9-2320-283-10.

EQUIPMENT CONDITIONPARAGRAPH

Air system draincocks

CONDITION DESCRIPTION

open.

TEST EQUIPMENT

None.

SPECIAL TOOLS

None.

MATERIALS/PARTS (P/N)Tape, thread sealing  
Item 32, Appendix C.PERSONNEL REQUIRED

One (MOS-63S).

SPECIAL ENVIRONMENTAL CONDITIONS

None.

REFERENCES (TM)

TM 9-2320-283-10.

GENERAL SAFETY INSTRUCTIONSEngine off.  
Transmission in neutral.  
Park brake set.TROUBLESHOOTING REFERENCES

Paragraph 2-11.

**3-1112**



**BRAKE SYSTEM.**

**3-188. PRIMARY AND SECONDARY RESERVOIR DRAINCOCK REPLACEMENT (Continued).**

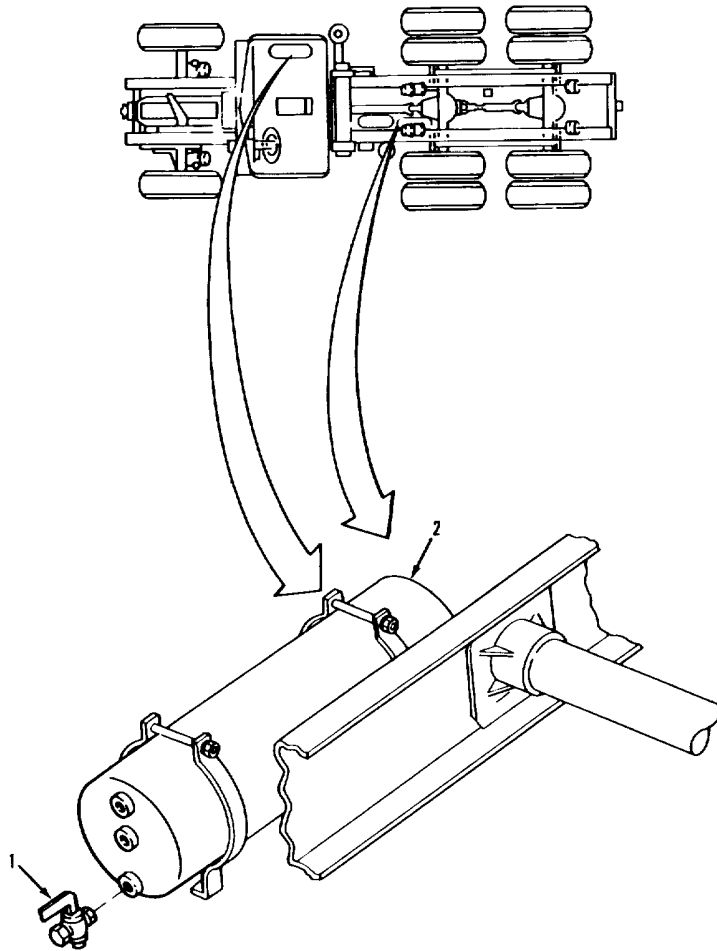

**LEGEND:**

- 1. DRAINCOCK
- 2. SECONDARY RESERVOIR

TA 237521

**BRAKE SYSTEM.**

3-188. PRIMARY AND SECONDARY RESERVOIR DRAINCOCK REPLACEMENT (Continued).		
LOCATION/ITEM	ACTION	REMARKS
<p><b>WARNING</b></p> <p>Never work on air system components without first draining air pressure. Failure to follow this precaution can result in serious personal injury.</p> <p><b>NOTE</b></p> <p>Primary and secondary reservoir draincock replacement procedures are the same. This procedure covers replacement of the secondary reservoir draincock.</p>		
<u>A. REMOVAL.</u>		
1. Draincock (1).	Unscrew and remove.	
<u>B. INSPECTION.</u>		
2. Draincock (1).	Inspect for damaged threads.	
<u>C. INSTALLATION.</u>		
3. Draincock (1).	Install and tighten.	Use thread sealing tape on threads.
<p><b>NOTE</b></p> <p><b>Follow-on maintenance action required:</b></p> <p>Close air system draincocks and start engine (TM 9-2320-283-10). Check air system for leaks (para 3-8).</p>		
3-1114		

3-188. PRIMARY AND SECONDARY RESERVOIR DRAINCOCK REPLACEMENT (Continued).

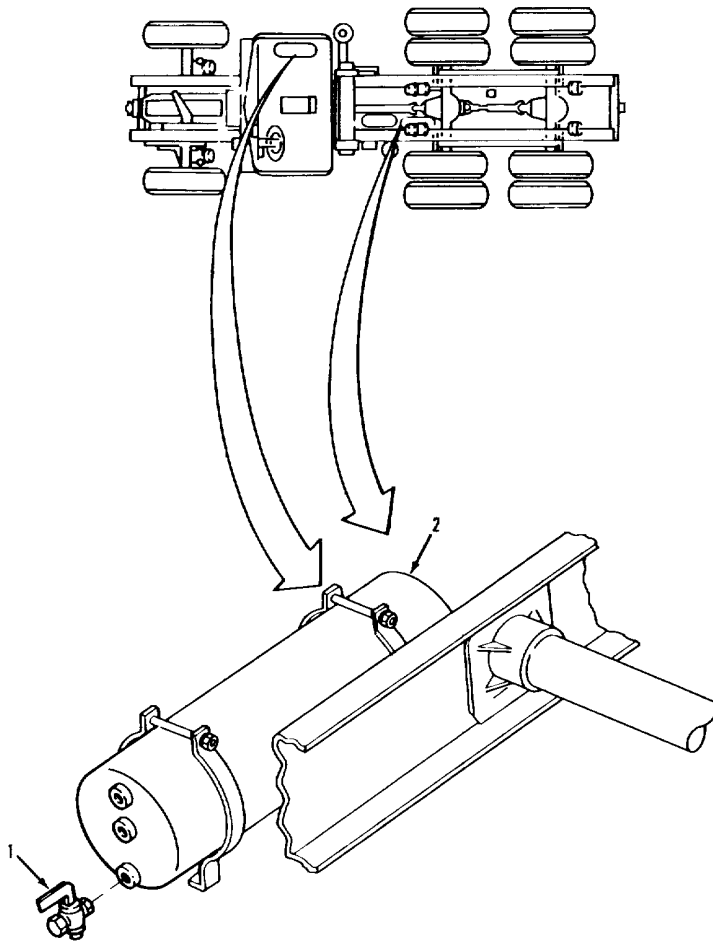

LEGEND:

- 1. DRAINCOCK
- 2. SECONDARY RESERVOIR

TA 237522

**BRAKE SYSTEM.****3-189. PRIMARY RESERVOIR CHECK VALVE REPLACEMENT.**

---

## THIS TASK COVERS

- a. Removal.
  - b. Installation.
- 

INITIAL SETUPAPPLICABLE CONFIGURATIONS

All. TM 9-2320-283-10.

EQUIPMENT CONDITION  
PARAGRAPH

Air system draincocks

CONDITION DESCRIPTION

open.

TEST EQUIPMENT

None.

SPECIAL TOOLS

None.

MATERIALS/PARTS (P/N)Tape, thread sealing  
Item 32, Appendix C.PERSONNEL REQUIRED

One (MOS-63S).

SPECIAL ENVIRONMENTAL CONDITIONS

None.

REFERENCES (TM)

TM 9-2320-283-10.

GENERAL SAFETY INSTRUCTIONSEngine off.  
Transmission in neutral.  
Park brake set.TROUBLESHOOTING REFERENCES

Paragraph 2-11.

**3-1116**

BRAKE SYSTEM.

3-189. PRIMARY RESERVOIR CHECK VALVE REPLACEMENT (Continued).

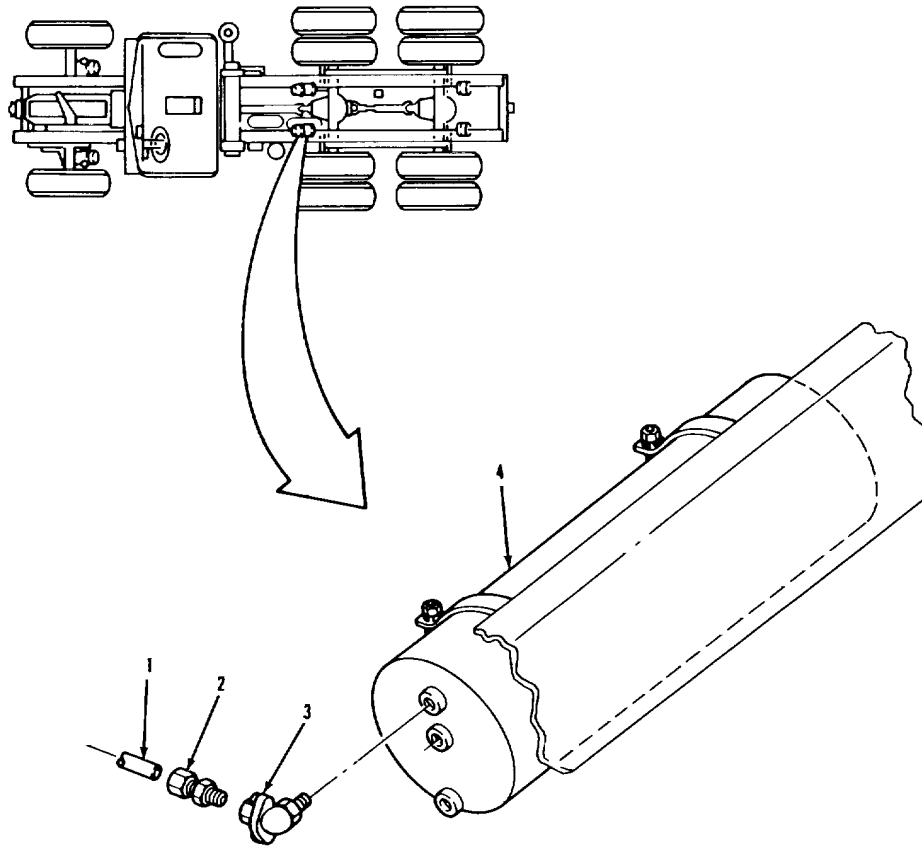

LEGEND:

- 1. AIR LINE
- 2. CONNECTOR
- 3. CHECK VALVE
- 4. PRIMARY RESERVOIR

TA 237523

**BRAKE SYSTEM.****3-189. PRIMARY RESERVOIR CHECK VALVE REPLACEMENT (Continued).**

LOCATION/ITEM	ACTION	REMARKS
<p><b><u>WARNING</u></b></p> <p><b>Never work on air system components without first draining air pressure. Failure to follow this precaution can result in serious personal injury.</b></p>		
<p><b><u>A. REMOVAL.</u></b></p>		
1. Air line (1).	Disconnect. Tag.	
2. Connector (2).	Remove from item (3).	
3. Check valve (3).	Remove from item (4).	
<p><b><u>B. INSTALLATION.</u></b></p>		
4. Check valve (3).	Install into item (4).	Use thread sealing tape on threads.
5. Connector (2).	Install into item (3).	Use thread sealing tape on threads.
6. Air line (1). Install and tighten.		
<p><b>NOTE</b></p> <p><b>Follow-on maintenance action required:</b></p> <p><b>Close air system draincocks and start engine (TM 9-2320-283-10). Check air system for leaks (para 3-8).</b></p>		
<p><b>3-1118</b></p>		

**BRAKE SYSTEM.**

**3-189. PRIMARY RESERVOIR CHECK VALVE REPLACEMENT (Continued).**

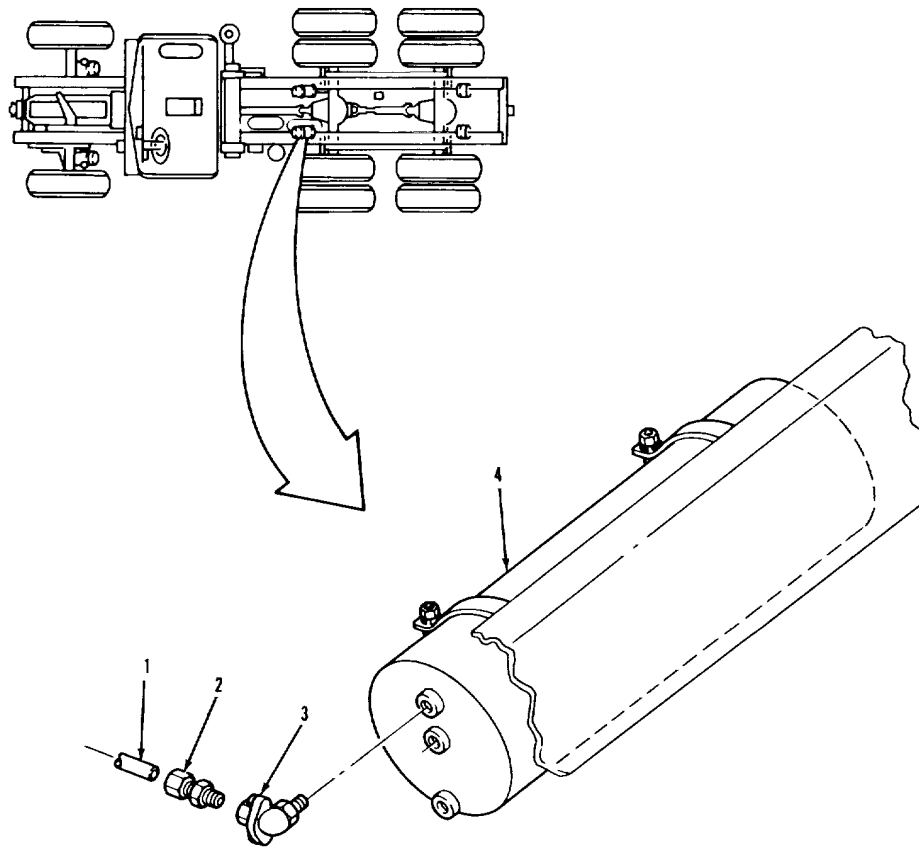

**LEGEND:**

- 1. AIR LINE
- 2. CONNECTOR
- 3. CHECK VALVE
- 4. PRIMARY RESERVOIR

TA 237524

**BRAKE SYSTEM.**

**3-190. SUPPLY RESERVOIR DRAIN VALVE REPLACEMENT.**

---

THIS TASK COVERS

- a. Removal.
  - b. Cleaning and Inspection.
  - c. Installation.
- 

INITIAL SETUP

APPLICABLE CONFIGURATIONS

All. TM 9-2320-283-10.

EQUIPMENT CONDITION

PARAGRAPH

Air system draincocks

CONDITION DESCRIPTION

opened.

TEST EQUIPMENT

None.

SPECIAL TOOLS

None.

MATERIALS/PARTS (P/N)

Tape, thread sealing

Item 32, Appendix C.

Solution, soap

Item 28, Appendix C.

PERSONNEL REQUIRED

One (MOS-63S).

SPECIAL ENVIRONMENTAL CONDITIONS

Work area clean and away from blowing

dirt and dust.

REFERENCES (TM)

TM 9-2320-283-10.

GENERAL SAFETY INSTRUCTIONS

Engine off.

Transmission in neutral.

Park brake set.

TROUBLESHOOTING REFERENCES

Paragraph 2-11.

**3-1120**



**BRAKE SYSTEM.**

**3-190. SUPPLY RESERVOIR DRAIN VALVE REPLACEMENT (Continued).**

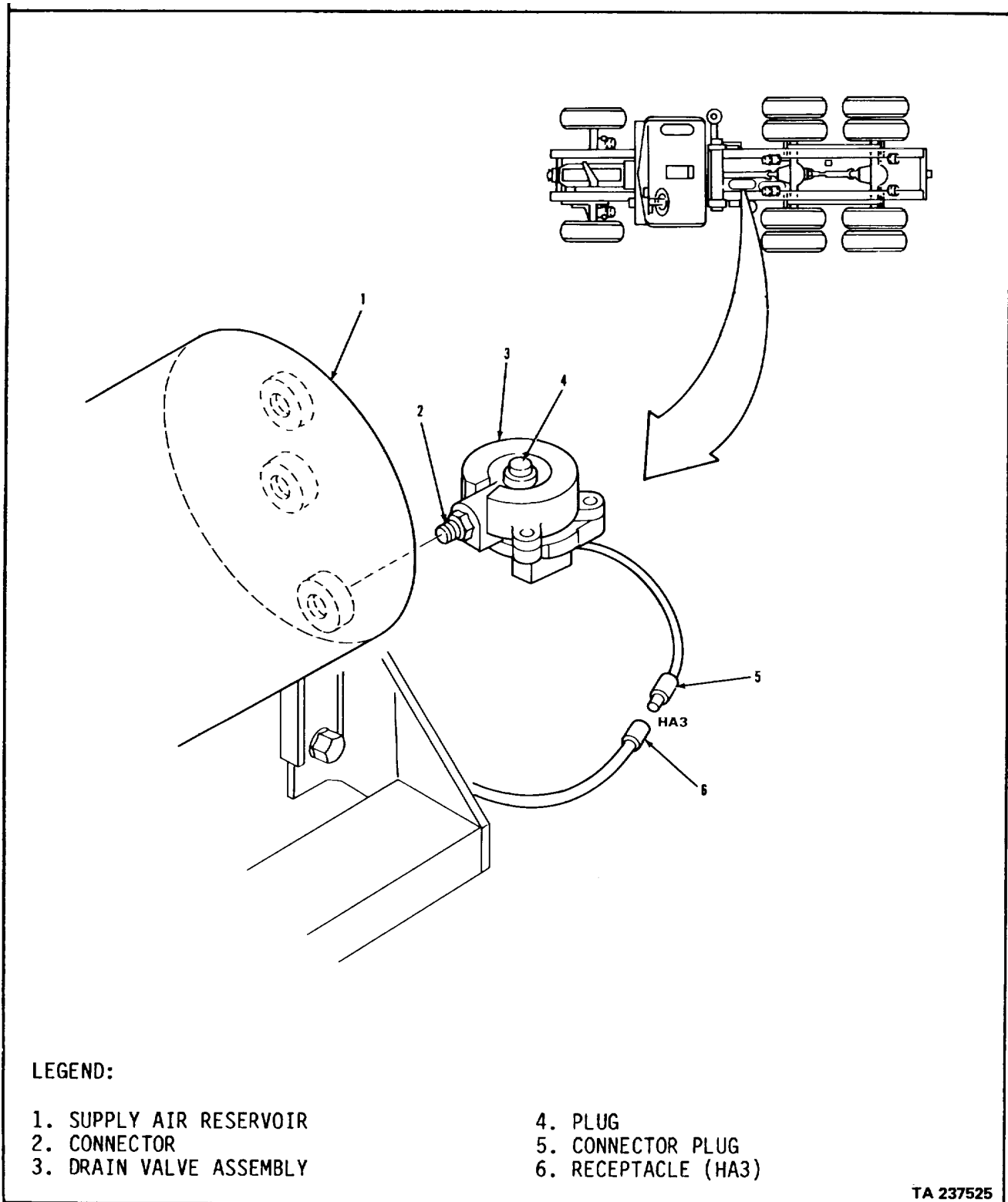

TA 237525

**BRAKE SYSTEM.**

3-190. SUPPLY RESERVOIR DRAIN VALVE REPLACEMENT (Continued).		
LOCATION/ITEM	ACTION	REMARKS
<b><u>WARNING</u></b>		
<p><b>Never work on air system components without first draining air pressure. Failure to follow this precaution can result in serious personal injury.</b></p>		
<b><u>A. REMOVAL.</u></b>		
1. Plug (5).	Remove from item (6).	
2. Valve (3) with attached connector (2).	Remove from item (1).	
<b><u>B. CLEANING AND INSPECTION.</u></b>		
3. All metal parts.	Clean and inspect.	Refer to paragraphs 3-4. and 3-5.
<b><u>C. INSTALLATION.</u></b>		
4. Connector (2).	Wrap threads with thread sealing tape.	Refer to paragraph 3-7.
5. Valve (3) with attached connector (2).	Install in item (1).	Point item (4) up.
6. Plug (5).	Connect to item (6).	
<b>NOTE</b>		
<p><b>Follow-on maintenance action required:</b></p> <p><b>Close air system draincocks and start engine (TM 9-2320-283-10). Check air system for leaks (para 3-8).</b></p>		

**BRAKE SYSTEM.**

**3-190. SUPPLY RESERVOIR DRAIN VALVE REPLACEMENT (Continued).**

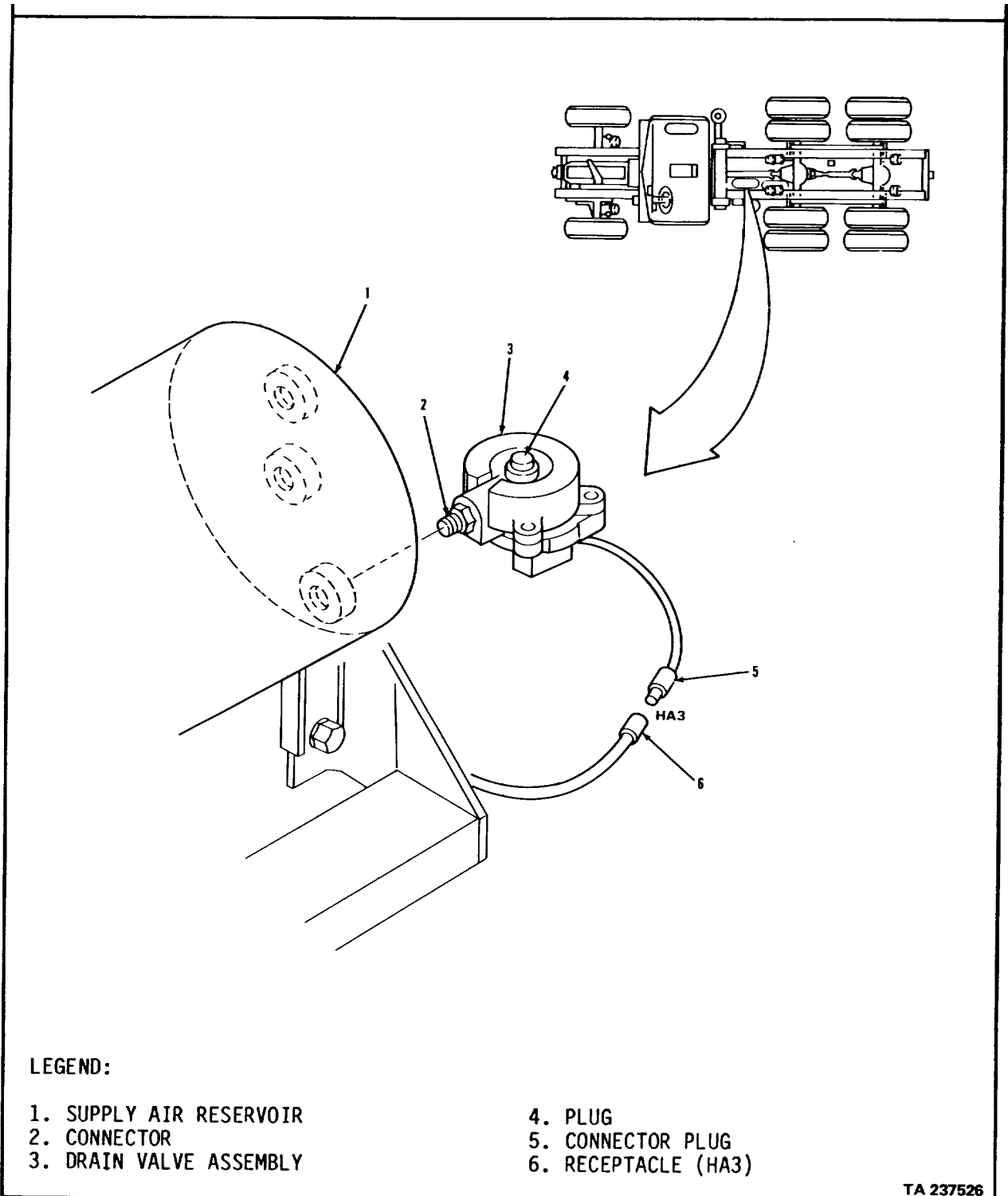

**BRAKE SYSTEM.**

**3-191. SUPPLY RESERVOIR SINGLE CHECK VALVE REPLACEMENT.**

**THIS TASK COVERS**

- a. Removal.
- b. Cleaning and Inspection.
- c. Installation.

**INITIAL SETUP**

APPLICABLE CONFIGURATIONS

All.

EQUIPMENT CONDITION PARAGRAPH

TM 9-2320-283-10.

CONDITION DESCRIPTION

Air system draincocks opened.

TEST EQUIPMENT

None.

SPECIAL TOOLS

None.

MATERIALS/PARTS (P/N)

Tape, thread sealing  
Item 32, Appendix C.  
Solution, soap  
Item 28, Appendix C.

PERSONNEL REQUIRED

One (MOS-63S).  
dirt and dust.

SPECIAL ENVIRONMENTAL CONDITIONS

Work area clean and away from blowing

REFERENCES (TM)

TM 9-2320-283-10.

GENERAL SAFETY INSTRUCTIONS

Engine off.  
Transmission in neutral.  
Park brake set.

TROUBLESHOOTING REFERENCES

Paragraph 2-11.

**BRAKE SYSTEM.**

**3-191. SUPPLY RESERVOIR SINGLE CHECK VALVE REPLACEMENT (Continued).**

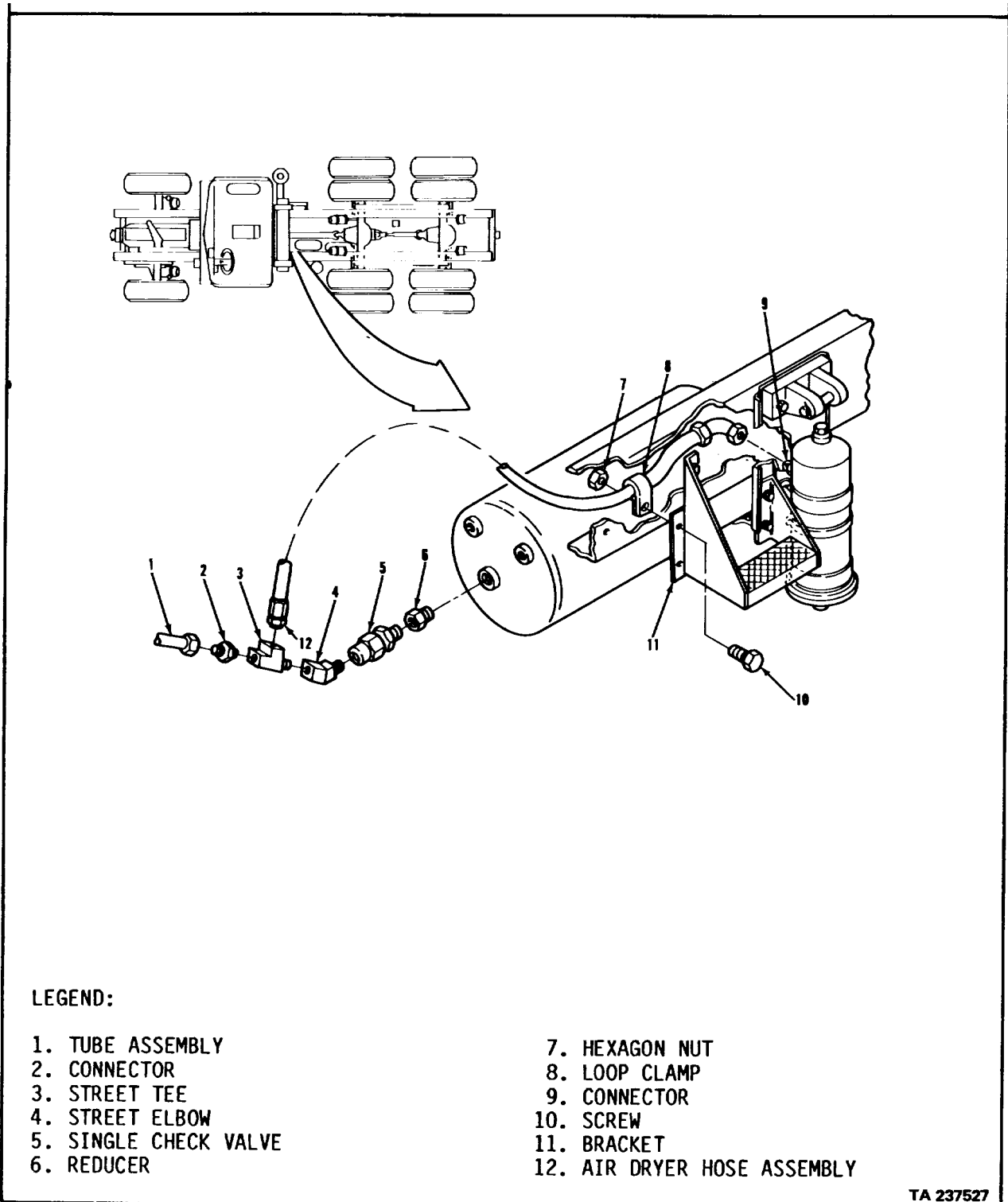

TA 237527

**BRAKE SYSTEM.**

3-191. SUPPLY RESERVOIR SINGLE CHECK VALVE REPLACEMENT (Continued).		
LOCATION/ITEM	ACTION	REMARKS
<u>A. REMOVAL.</u>		
1 Screw (10) and nut (7).	Remove from items (8) and (11).	
2. Hose (12). (3).	Remove from items (9) and item (9) first.	Remove item (12) from
3. Tube (1).	Remove from item (2).	
4. Connector (2).	Remove from item (3).	
5. Tee (3).	Remove from item (4).	
6. Elbow (4).	Remove from item (5).	
7. Valve (5).	Remove from item (6).	Item (5) consists of two parts.
<u>B. CLEANING AND INSPECTION.</u>		
8. All metal parts.	Clean and inspect.	Refer to paragraphs 3-4 and 3-5.
<u>C. INSTALLATION.</u>		
9. Valve (5).	a. Wrap threads with thread sealing tape. b. Install in item (6).	Refer to paragraph 3-7.
10. Elbow (4).	a. Wrap threads with thread sealing tape. b. Install in item (5).	Refer to paragraph 3-7. Point item (4) up.
11. Tee (3).	a. Wrap threads with thread b. Install in item (4)	Refer to paragraph 3-7. sealing tape. Point side port toward left side.

**BRAKE SYSTEM.**

**3-191. SUPPLY RESERVOIR SINGLE CHECK VALVE REPLACEMENT (Continued).**

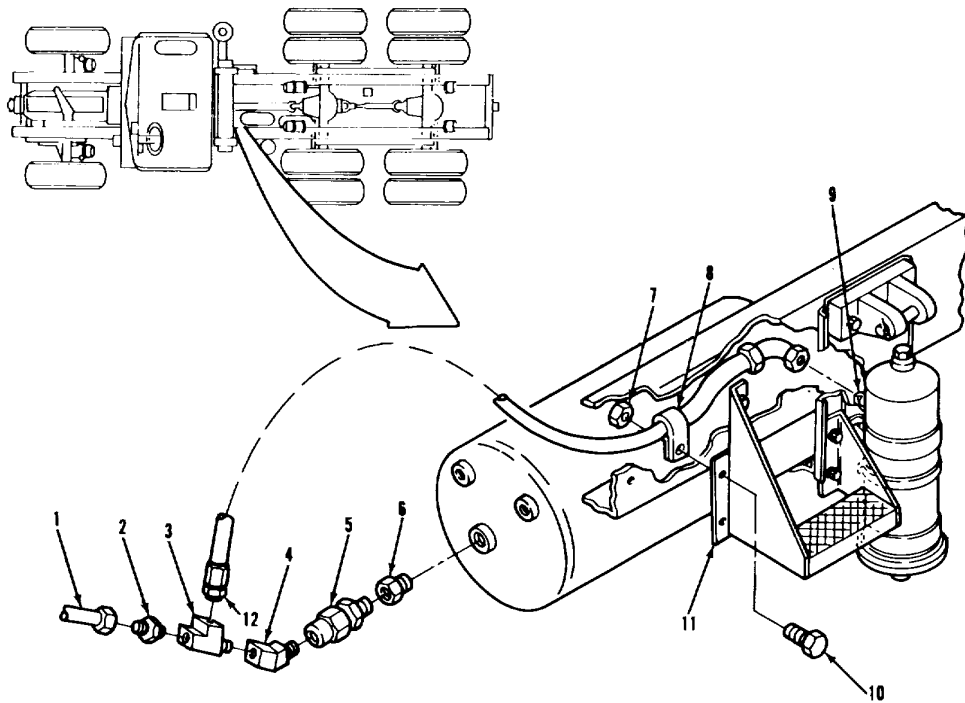

**LEGEND:**

- 1. TUBE ASSEMBLY
- 2. CONNECTOR
- 3. STREET TEE
- 4. STREET ELBOW
- 5. SINGLE CHECK VALVE
- 6. REDUCER

- 7. HEXAGON NUT
- 8. LOOP CLAMP
- 9. CONNECTOR
- 10. SCREW
- 11. BRACKET
- 12. AIR DRYER HOSE ASSEMBLY

TA 237528

**BRAKE SYSTEM.**

<b>3-191. SUPPLY RESERVOIR SINGLE CHECK VALVE REPLACEMENT (Continued).</b>		
<b>LOCATION/ITEM</b>	<b>ACTION</b>	<b>REMARKS</b>
<u>C INSTALLATION (Continued).</u>		
12. Connector (2)	a. Wrap threads with thread sealing tape.	Point side port toward left side.
13. Tube (1). sealing tape.	b. Screw into item (3).	
	a. Wrap threads with thread	Refer to paragraph 3-7.
14. Hose (12). sealing tape.	b. Install on item (2).	
	a. Wrap threads with thread	Refer to paragraph 3-7.
15. Clamp (8).	b. Install on items (3) and (9).	
	a. Install on item (12).	
	b. Place in position on item (11).	
	c. Secure in place with two items (7) and (10).	
<b>NOTE</b>		
<b>Follow-on maintenance action required:</b>		
Close air system draincocks and start engine (TM 9-2320-283-10). Check air system for leaks (para 3-8).		
<b>3-1128</b>		



**BRAKE SYSTEM.**

**3-191. SUPPLY RESERVOIR SINGLE CHECK VALVE REPLACEMENT (Continued).**

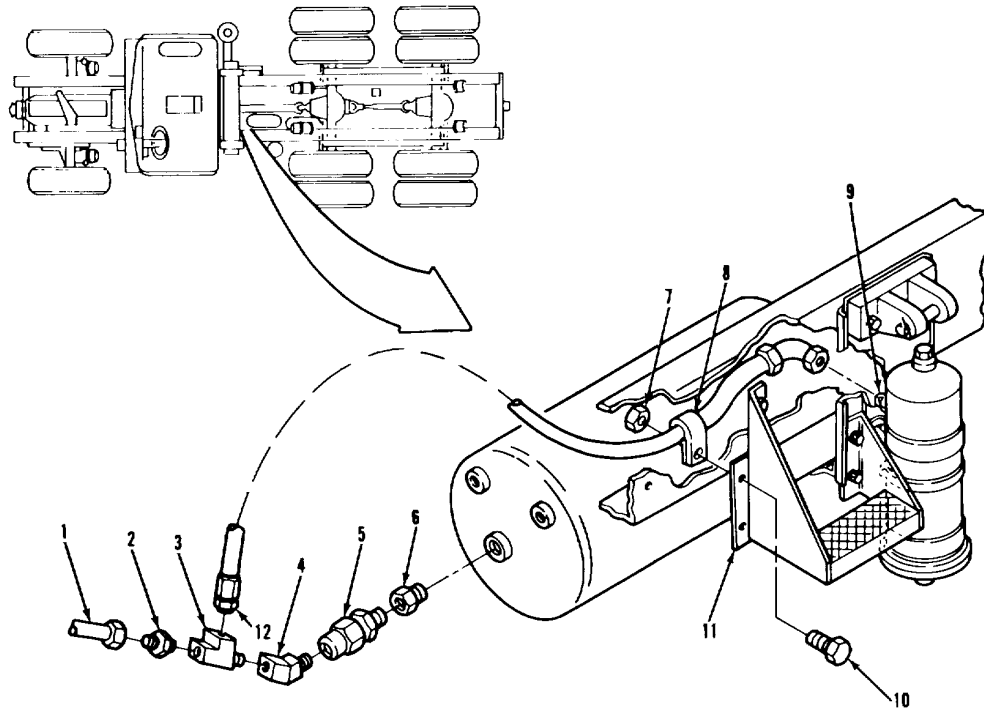

**LEGEND:**

- 1. TUBE ASSEMBLY
- 2. CONNECTOR
- 3. STREET TEE
- 4. STREET ELBOW
- 5. SINGLE CHECK VALVE
- 6. REDUCER

- 7. HEXAGON NUT
- 8. LOOP CLAMP
- 9. CONNECTOR
- 10. SCREW
- 11. BRACKET
- 12. AIR DRYER HOSE ASSEMBLY

TA 237529

**BRAKE SYSTEM.**

**3-192. TRACTOR PROTECTION VALVE REPLACEMENT**

THIS TASK COVERS

- a. Removal.
- b. Cleaning and Inspection.
- c. Installation.

INITIAL SETUP

APPLICABLE CONFIGURATIONS

All.

EQUIPMENT CONDITION

PARAGRAPH

TM 9-2320-283-10.

CONDITION DESCRIPTION

Air system draincocks opened.

TEST EQUIPMENT

None.

SPECIAL TOOLS

None.

MATERIALS/PARTS (P/N)

Tape, thread sealing  
Item 32, Appendix C.  
Solution, soap  
Item 28, Appendix C.

PERSONNEL REQUIRED

One (MOS-63S).

SPECIAL ENVIRONMENTAL CONDITIONS

Work area clean and away from blowing dirt and dust.

REFERENCES (TM)

TM 9-2320-2 3-10.

GENERAL SAFETY INSTRUCTIONS

Engine off.  
Transmission in neutral.  
Park brake set.

TROUBLESHOOTING REFERENCES

Paragraph 2-11.

BRAKE SYSTEM.

3-192. TRACTOR PROTECTION VALVE REPLACEMENT (Continued).

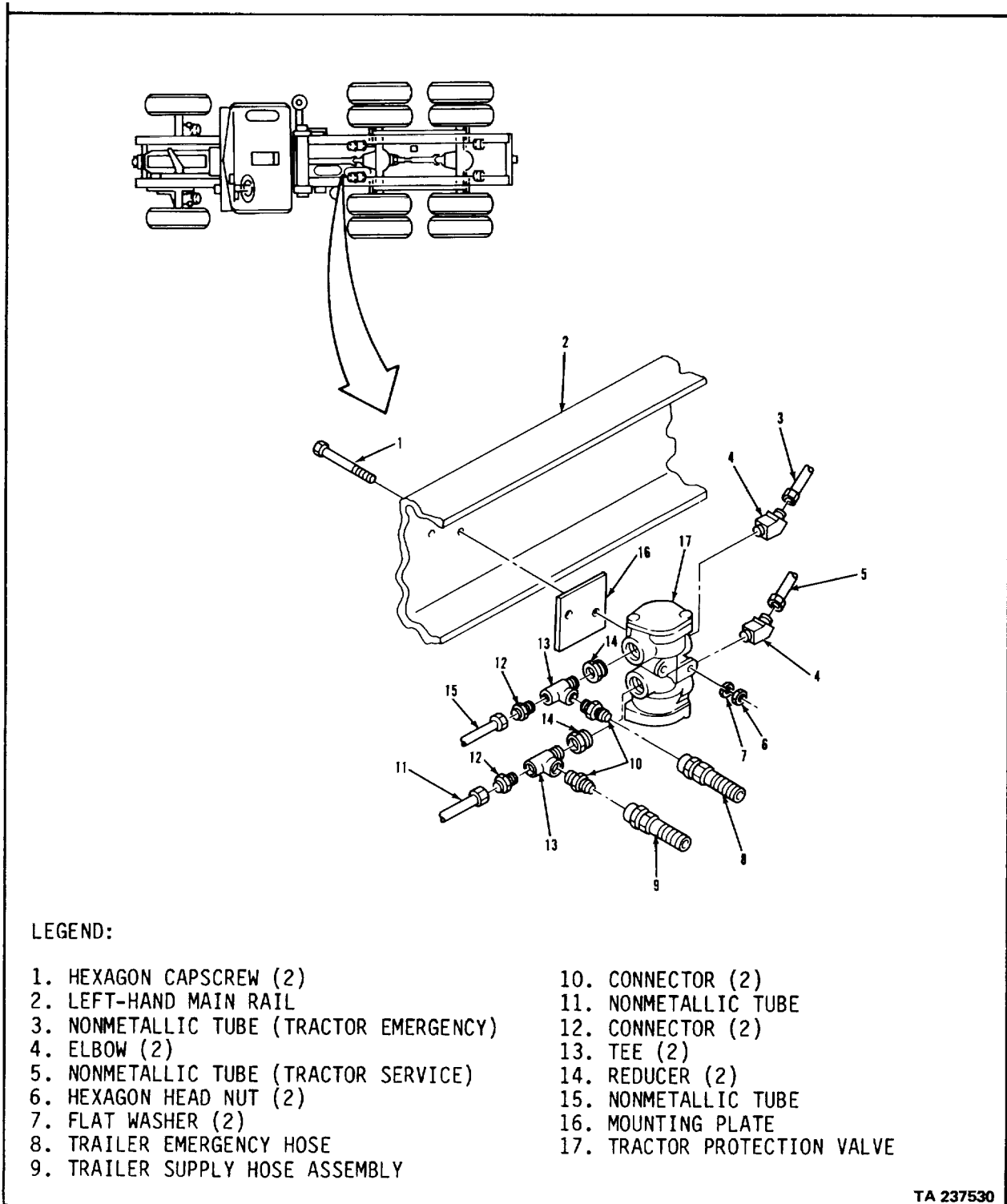

TA 237530

**BRAKE SYSTEM.**

3-192. TRACTOR PROTECTION VALVE REPLACEMENT (Continued).		
LOCATION/ITEM	ACTION	REMARKS
<p><u>A. REMOVAL.</u></p> <p style="text-align: center;"><b><u>WARNING</u></b>  <b>Never work on air system components without first draining air pressure. Failure to follow this precaution can result in serious personal injury.</b></p>		
1. Two hoses (8) and (9).	Remove from two items (10).	Hold items (10) when removing items (8) and (9).
2. Two tubes (3) and (5).	Remove from two items (4).	Tag for identification.
3. Two tubes (11) and (15).	Remove from two items (12).	Tag for identification.
4. Two capscrews (1), washers (7) and nuts (6).	<p>a. Remove from item (2), (16), and (17).</p> <p>b. Remove item (16) and (17) from item (2).</p>	
5. Valve (17).	Position in suitable vise.	
6. Two connectors (10).	Remove from item (13).	Tag for identification.
7. Two connectors (12).	Remove from two items (13).	Tag for identification.
8. Two tees (13).	Remove from items (14).	Tag for identification.
9. Two elbows (4).	Remove from item (17).	Tag for identification.
10. Two reducers (14).	<p>a. Remove from item (17).</p> <p>b. Remove item (17) from vise.</p>	Tag for identification.
3-1132		

**BRAKE SYSTEM.**

**3-192. TRACTOR PROTECTION VALVE REPLACEMENT (Continued).**

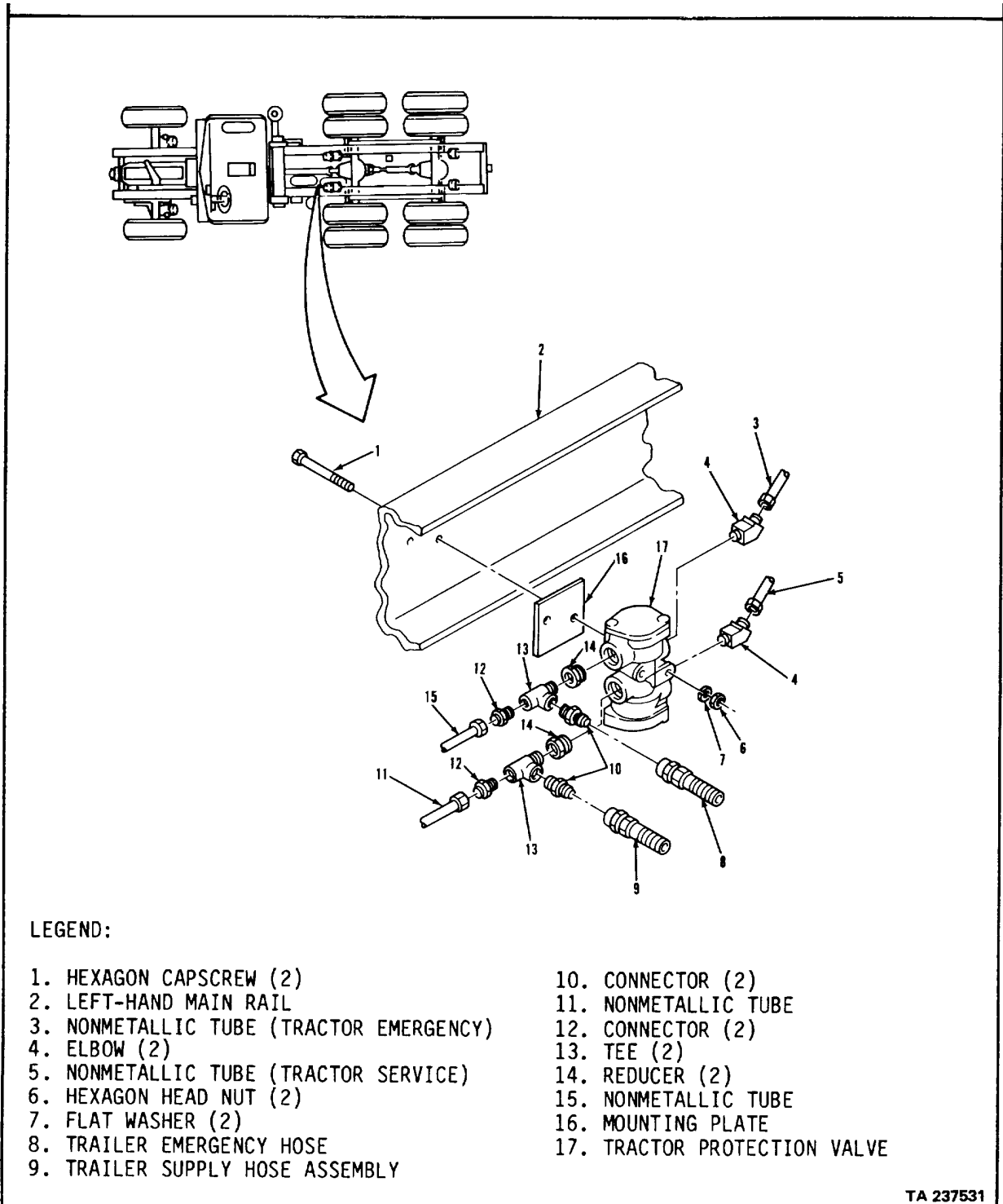

TA 237531

**BRAKE SYSTEM.**

<b>3-192. TRACTOR PROTECTION VALVE REPLACEMENT (Continued).</b>		
<b>LOCATION/ITEM</b>	<b>ACTION</b>	<b>REMARKS</b>
<u><b>B. CLEANING AND INSPECTION.</b></u>		
11. All metal parts.	Clean and inspect.	Refer to paragraphs 3-4 and 3-5.
<u><b>C. INSTALLATION.</b></u>		
12. Valve (17).	Position in suitable vise.	
13. Two reducers (14).	a. Wrap threads with thread sealing tape. b. Install in item (17).	Refer to paragraph 3-7.
14. Two tees (13). sealing tape.	a. Wrap threads with thread  b. Install on items (14).	Refer to paragraph 3-7.  Point toward right side.
15. Two connectors (12).	a. Wrap threads with thread sealing tape. b. Install on two items (13).	Refer to paragraph 3-7.
16. Two connectors (10).	a. Wrap threads with thread sealing tape. b. Install on two items (13).	Refer to paragraph 3-7.
17. Two elbows (4).	a. Wrap threads with thread sealing  b. Install on item (17). c. Remove item (17) from vise.	Refer to paragraph 3-7.
18. Plate (16) and valve (17).	a. Line up with holes in item (2). b. Secure with two items (6), (7) and (1).	

BRAKE SYSTEM.

3-192. TRACTOR PROTECTION VALVE REPLACEMENT (Continued).

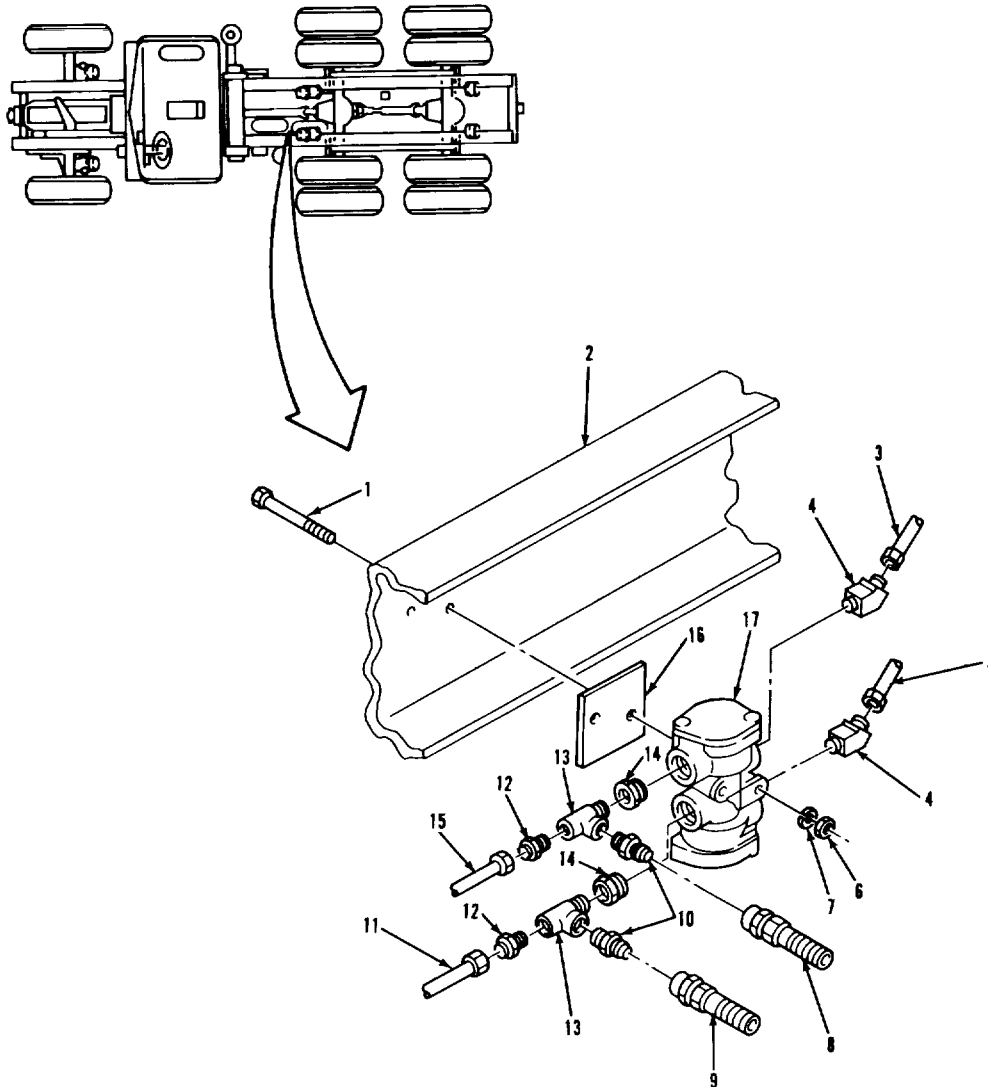

LEGEND:

- |   |                              |
|---|------------------------------|
| 1. HEXAGON CAPSCREW (2)                 | 10. CONNECTOR (2)            |
| 2. LEFT-HAND MAIN RAIL                  | 11. NONMETALLIC TUBE         |
| 3. NONMETALLIC TUBE (TRACTOR EMERGENCY) | 12. CONNECTOR (2)            |
| 4. ELBOW (2)                            | 13. TEE (2)                  |
| 5. NONMETALLIC TUBE (TRACTOR SERVICE)   | 14. REDUCER (2)              |
| 6. HEXAGON HEAD NUT (2)                 | 15. NONMETALLIC TUBE         |
| 7. FLAT WASHER (2)                      | 16. MOUNTING PLATE           |
| 8. TRAILER EMERGENCY HOSE               | 17. TRACTOR PROTECTION VALVE |
| 9. TRAILER SUPPLY HOSE ASSEMBLY         |                              |

TA 237532

**BRAKE SYSTEM.**

3-192. TRACTOR PROTECTION VALVE REPLACEMENT (Continued).		
LOCATION/ITEM	ACTION	REMARKS
<u>C. INSTALLATION (Continued)</u>		
19. Tube (11) and (15).	Install on two items (12).	
20. Tube (3) and (5).	Install on two items (4).	
21. Hose (8) and (9).	Install on two items (10).	
<b>NOTE</b>		
<b>Follow-on maintenance action required:</b>		
<b>Close air system draincocks and start engine (TM 9-2320-283-10). Check air system for leaks (para3-8).</b>		
<b>3-1136</b>		



BRAKE SYSTEM.

3-192. TRACTOR PROTECTION VALVE REPLACEMENT (Continued).

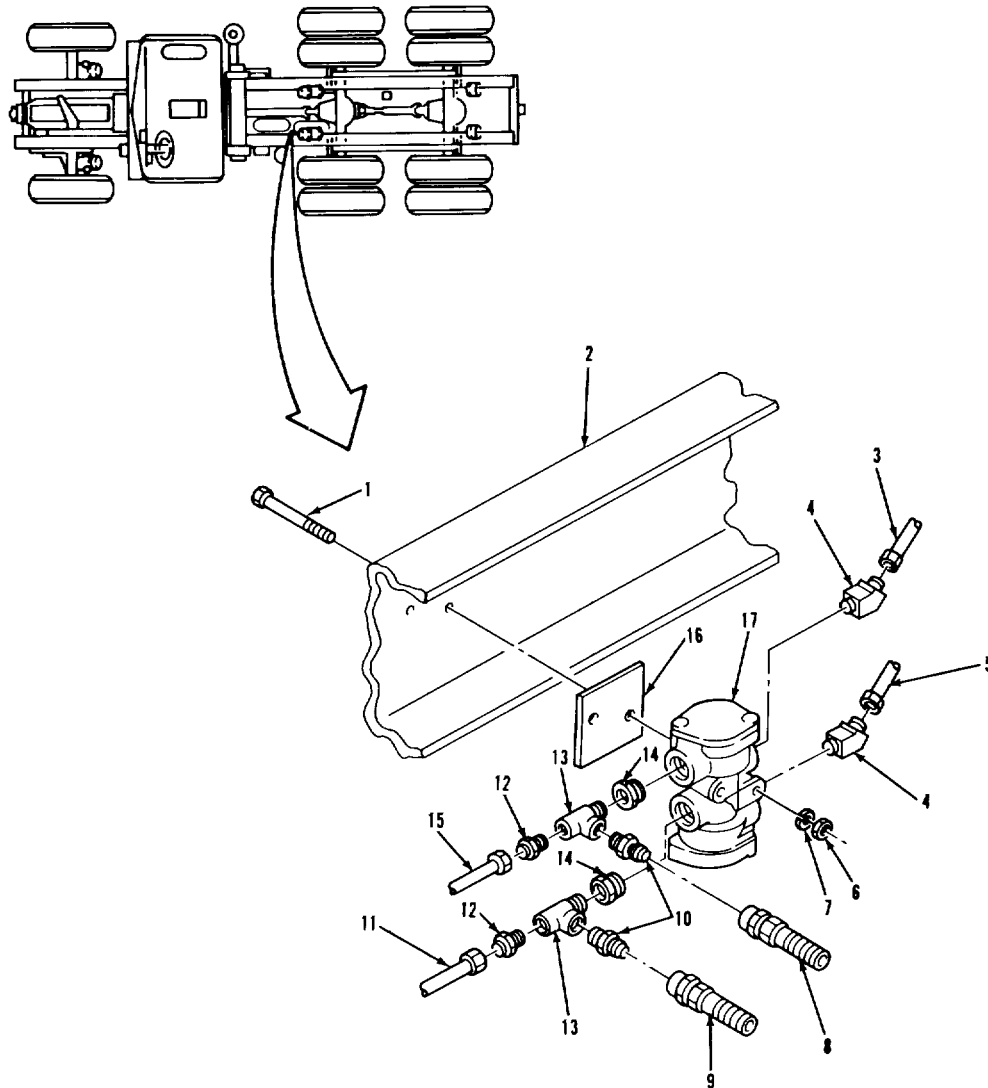

LEGEND:

- |   |                              |
|---|------------------------------|
| 1. HEXAGON CAPSCREW (2)                 | 10. CONNECTOR (2)            |
| 2. LEFT-HAND MAIN RAIL                  | 11. NONMETALLIC TUBE         |
| 3. NONMETALLIC TUBE (TRACTOR EMERGENCY) | 12. CONNECTOR (2)            |
| 4. ELBOW (2)                            | 13. TEE (2)                  |
| 5. NONMETALLIC TUBE (TRACTOR SERVICE)   | 14. REDUCER (2)              |
| 6. HEXAGON HEAD NUT (2)                 | 15. NONMETALLIC TUBE         |
| 7. FLAT WASHER (2)                      | 16. MOUNTING PLATE           |
| 8. TRAILER EMERGENCY HOSE               | 17. TRACTOR PROTECTION VALVE |
| 9. TRAILER SUPPLY HOSE ASSEMBLY         |                              |

TA 237533

**BRAKE SYSTEM.**

**3-193. BRAKE PEDAL DOUBLE CHECK VALVE REPLACEMENT.**

THIS TASK COVERS

- a. Removal.
- b. Cleaning and Inspection.
- c. Installation.

INITIAL SETUP

APPLICABLE CONFIGURATIONS  
All.

EQUIPMENT CONDITION  
PARAGRAPH  
TM 9-2320-283-10.  
opened.

CONDITION DESCRIPTION  
Air system draincocks

TEST EQUIPMENT

None.

SPECIAL TOOLS

None.

MATERIALS/PARTS (P/N)

Tape, thread sealing  
Item 32, Appendix C.  
Solution, soap  
Item 28, Appendix C.

PERSONNEL REQUIRED

One (MOS-63S).

SPECIAL ENVIRONMENTAL CONDITIONS

Work area clean and away from blowing dirt and dust.

REFERENCES (TM)

TM 9-2320-283-10.

GENERAL SAFETY INSTRUCTIONS

Engine off.  
Transmission in neutral.  
Park brake set.

TROUBLESHOOTING REFERENCES

Paragraph 2-11.

**3-1138**

**BRAKE SYSTEM.**

**3-193. BRAKE PEDAL DOUBLE CHECK VALVE REPLACEMENT (Continued).**

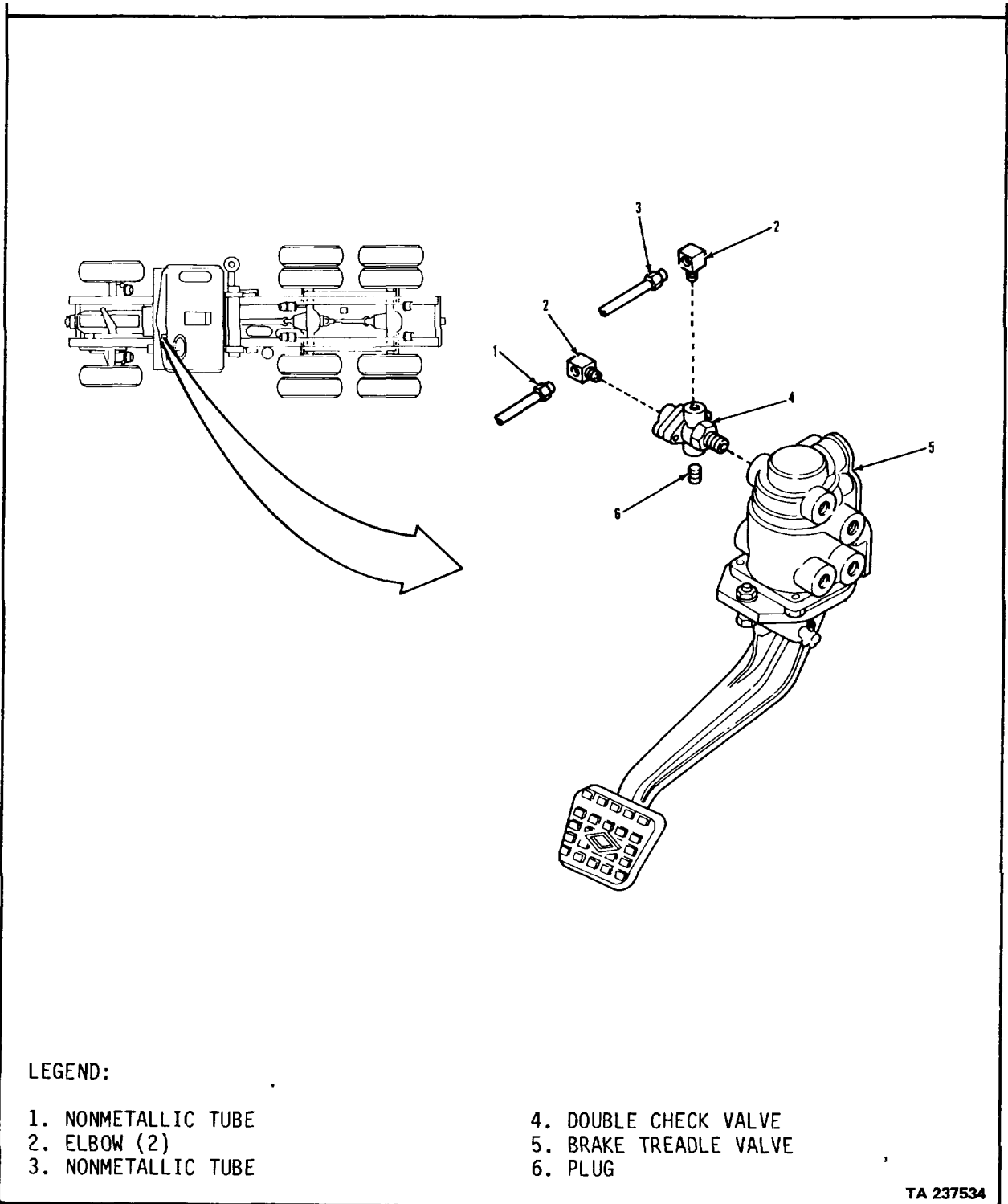

**BRAKE SYSTEM.**

<b>3-193. BRAKE PEDAL DOUBLE CHECK VALVE REPLACEMENT (Continued).</b>		
<b>LOCATION/ITEM</b>	<b>ACTION</b>	<b>REMARKS</b>
<u>A. REMOVAL.</u>		
1. Tubes (1) and (3)	Remove from two items (2).	Tag for identification.
2. Two elbows (2).	Remove from item (4).	
3. Plug (6).	Remove from item (4).	
4. Valve (4).	Remove from item (5).	
<u>B. CLEANING AND INSPECTION.</u>		
5. All metal parts.	Clean and inspect.	Refer to paragraphs 3-4 and 3-5.
<u>C. INSTALLATION</u>		
<b>NOTE</b>		
<b>Install valve with plug port down.</b>		
6. Valve (4).	a. Wrap threads with thread sealing tape.	Refer to paragraph 3-7.
	b. Install on item (5).	
7. Plug (6).	a. Wrap with thread sealing tape.	Refer to paragraph 3-7.
	b. Install in item (4).	
8. Two elbows (2).	a. Wrap with thread sealing tape.	Refer to paragraph 3-7.
	b. Install into item (4).	
9. Tubes (1) and (3).	Install on two items (2).	
<b>3-1140</b>		

**BRAKE SYSTEM.**

**3-193. BRAKE PEDAL DOUBLE CHECK VALVE REPLACEMENT (Continued).**

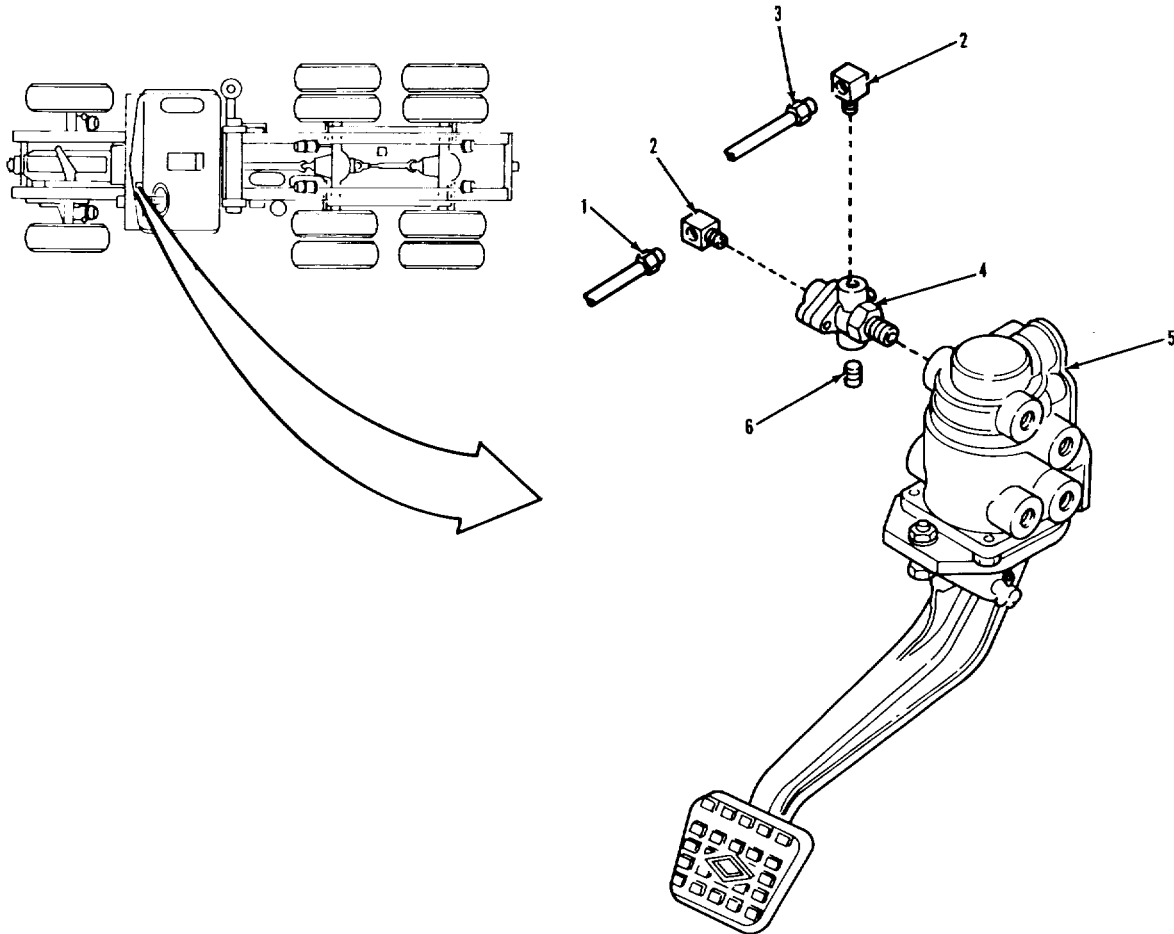

**LEGEND:**

- 1. NONMETALLIC TUBE
- 2. ELBOW (2)
- 3. NONMETALLIC TUBE

- 4. DOUBLE CHECK VALVE
- 5. BRAKE TREADLE VALVE
- 6. PLUG

TA 237535

**BRAKE SYSTEM.**

3-193. BRAKE PEDAL DOUBLE CHECK VALVE REPLACEMENT (Continued).		
LOCATION/ITEM	ACTION	REMARKS
<p><u>C</u> <u>INSTALLATION (Continued).</u></p> <p style="text-align: center;"><b>NOTE</b></p> <p><b>Follow-on maintenance action required:</b></p> <p><b>Close air system draincocks and start engine (TM 9-2320-283-10). Check air system for leaks (para 3-8).</b></p> <p style="text-align: center;"><b>3-1142</b></p>		

**BRAKE SYSTEM.**

**3-193. BRAKE PEDAL DOUBLE CHECK VALVE REPLACEMENT (Continued).**

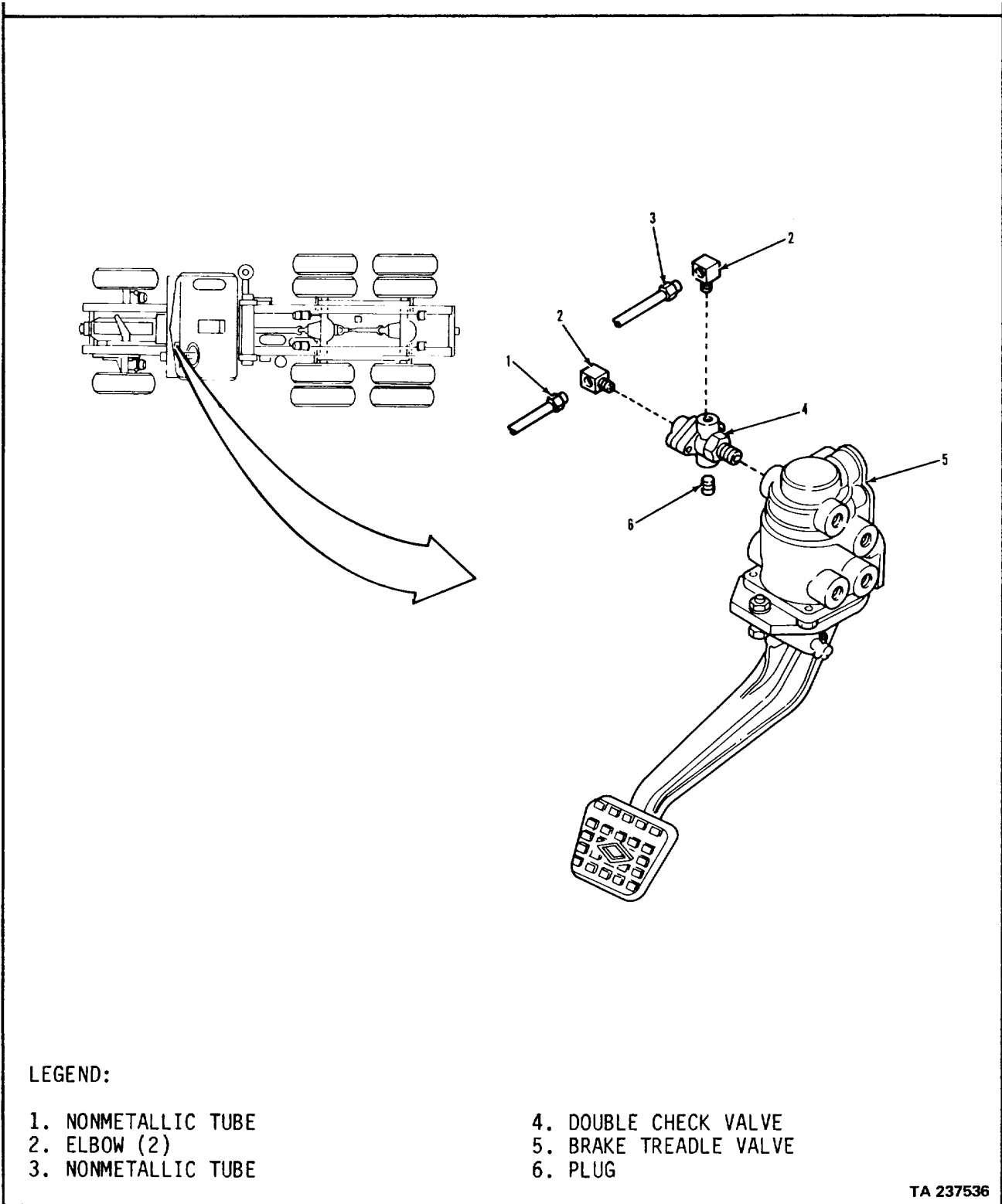

**BRAKE SYSTEM.**

<b>3-194. FIFTH WHEEL TOGGLE VALVE REPLACEMENT</b>		
<u>THIS TASK COVERS</u> a. Removal. b. Cleaning and Inspection. c. Installation.		
<u>INITIAL SETUP</u>		
<u>APPLICABLE CONFIGURATIONS</u> All.	<u>EQUIPMENT CONDITION PARAGRAPH</u> TM 9-2320-283-10.	<u>CONDITION DESCRIPTION</u> Air system draincocks opened.
<u>TEST EQUIPMENT</u> None.		
<u>SPECIAL TOOLS</u> None.		
<u>MATERIALS/PARTS (P/N)</u> Tape, thread sealing Item 32, Appendix C. Solution, soap Item 28, Appendix C.	Decal, locking positions, cab controlled fifth wheel (34623) 5995161 (if required).	
<u>PERSONNEL REQUIRED</u> One (MOS-63S). dirt and dust.	<u>SPECIAL ENVIRONMENTAL CONDITIONS</u> Work area clean and away from blowing	
<u>REFERENCES (TM)</u> TM 9-2320-2 3-10. Transmission in neutral. Park brake set.	<u>GENERAL SAFETY INSTRUCTIONS</u> Engine off.	
<u>TROUBLESHOOTING REFERENCES</u> Paragraph 2-11.		
<b>3-1144</b>		



**BRAKE SYSTEM.**

**3-194. FIFTH WHEEL TOGGLE VALVE REPLACEMENT (Continued).**

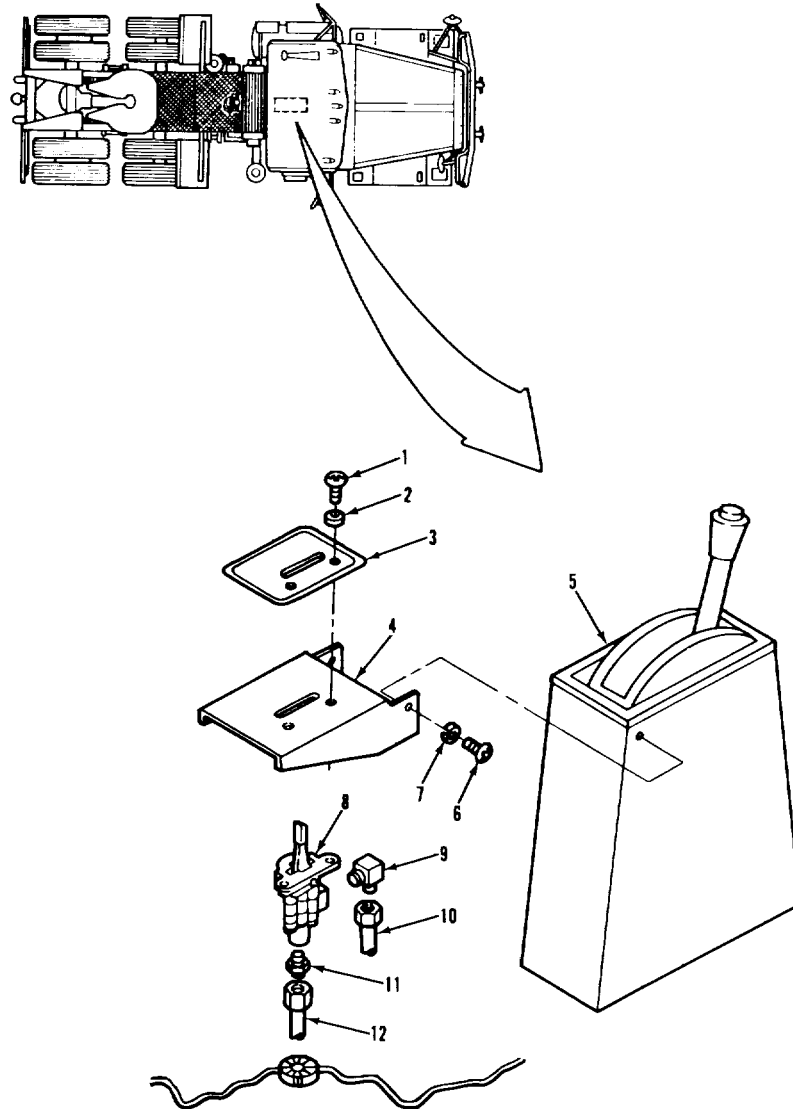

**LEGEND:**

- |  |                      |
|--|----------------------|
| 1. MACHINE SCREW (2)                                     | 6. SCREW (2)         |
| 2. FLAT WASHER (2)                                       | 7. LOCKWASHER (2)    |
| 3. CAB CONTROLLED FIFTH WHEEL<br>LOCKING POSITIONS DECAL | 8. TOGGLE VALVE      |
| 4. FIFTH WHEEL CONTROL BRACKET                           | 9. ELBOW             |
| 5. TRANSMISSION CONTROL MOUNTING<br>BRACKET ASSEMBLY     | 10. NONMETALLIC TUBE |
|  | 11. CONNECTOR        |
|  | 12. NONMETALLIC TUBE |

TA 237537

**BRAKE SYSTEM.**

3-194. FIFTH WHEEL TOGGLE VALVE REPLACEMENT (Continued).		
LOCATION/ITEM	ACTION	REMARKS
<b><u>WARNING</u></b>		
<b>Never work on air system components without first draining air pressure. Failure to follow this precaution can result in serious personal injury.</b>		
<b><u>A. REMOVAL</u></b>		
1. Tube (12).	Remove from item (11).	Tag for identification.
2. Tube (10).	Remove from item (9).	Tag for identification.
3. Two screws (1) and flat washers (2).	a. Remove from item (3), (4), and (8). b. Remove item (8) from item (4).	
4. Elbow (9).	Remove from item (8).	
5. Connector (11).	Remove from item (8).	
<b>NOTE</b>		
To remove fifth wheel control bracket, do step 6; otherwise, go to step 7.		
6. Two screws (6) and lockwashers (7).	a. Remove from item (4). b. Remove item (4) from item (5).	
<b>NOTE</b>		
<b>Do step 7 only if decal is damaged.</b>		
7. Decal (3).	Remove from item (4).	Discard item (3).
<b>3-1146</b>		

**BRAKE SYSTEM.**

**3-194. FIFTH WHEEL TOGGLE VALVE REPLACEMENT (Continued).**

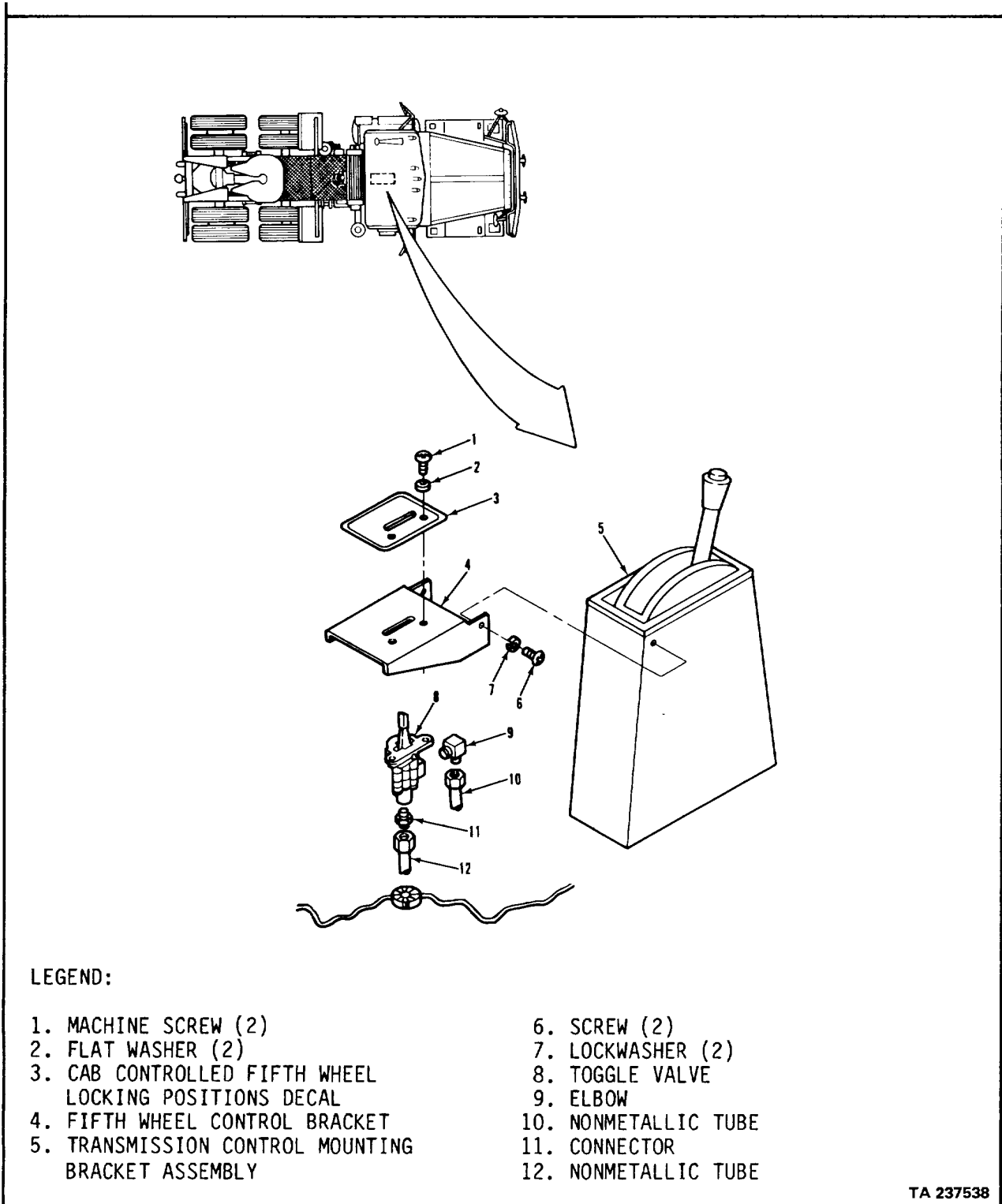

TA 237538

**BRAKE SYSTEM.**

3-194. FIFTH WHEEL TOGGLE VALVE REPLACEMENT (Continued).		
LOCATION/ITEM	ACTION	REMARKS
<u>B. CLEANING AND INSPECTION.</u>		
8. All metal parts and 3-5.	Clean and inspect.	Refer to paragraphs 3-4
<u>C. INSTALLATION.</u>		
<b>NOTE</b>		
<b>If decal was replaced, do step 9; otherwise, go to step 10.</b>		
9. New decal (3).	<ul style="list-style-type: none"> <li>a. Peel off backing.</li> <li>b. Line up on item (4) and press firmly to secure.</li> </ul>	
<b>NOTE</b>		
<b>If bracket was replaced, do step 10; otherwise, go to step 11.</b>		
10. Bracket (4)	<ul style="list-style-type: none"> <li>a. Line up holes in item (4) with holes in item (5).</li> <li>b. Secure with two items (6) and (7).</li> </ul>	
11. Connector (11)	<ul style="list-style-type: none"> <li>a. Wrap threads with thread sealing.</li> <li>b. Install on item (8).</li> </ul>	Refer to paragraph 3-7.
12. Elbow (9).	<ul style="list-style-type: none"> <li>a. Wrap threads with thread sealing tape.</li> <li>b. Install on item (8).</li> </ul>	Refer to paragraph 3-7.
<b>3-1148</b>		

**BRAKE SYSTEM.**

**3-194. FIFTH WHEEL TOGGLE VALVE REPLACEMENT (Continued).**

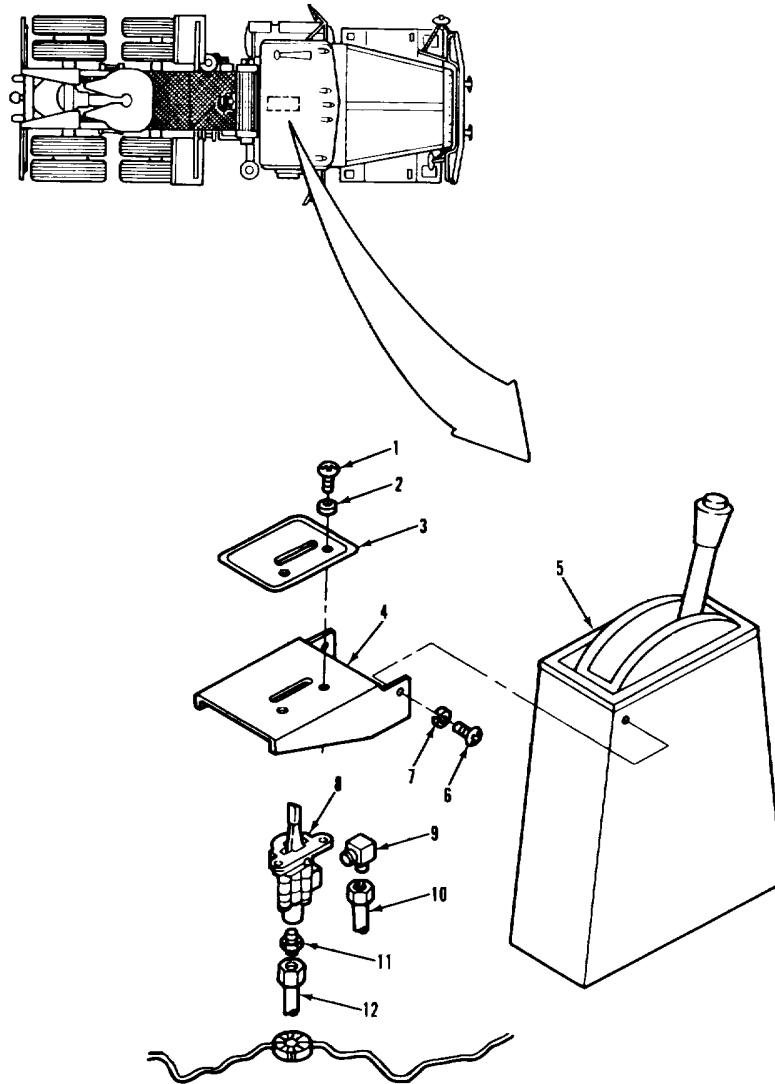

**LEGEND:**

- |  |                      |
|--|----------------------|
| 1. MACHINE SCREW (2)                                     | 6. SCREW (2)         |
| 2. FLAT WASHER (2)                                       | 7. LOCKWASHER (2)    |
| 3. CAB CONTROLLED FIFTH WHEEL<br>LOCKING POSITIONS DECAL | 8. TOGGLE VALVE      |
| 4. FIFTH WHEEL CONTROL BRACKET                           | 9. ELBOW             |
| 5. TRANSMISSION CONTROL MOUNTING<br>BRACKET ASSEMBLY     | 10. NONMETALLIC TUBE |
|  | 11. CONNECTOR        |
|  | 12. NONMETALLIC TUBE |

TA 237539

**BRAKE SYSTEM.**

3-194. FIFTH WHEEL TOGGLE VALVE REPLACEMENT (Continued).		
LOCATION/ITEM	ACTION	REMARKS
<u>C. INSTALLATION (Continued)</u>		
13. Valve (8).	a. Place in position.	Item (9) faces front of vehicle.
	b. Secure with two items (1) and (2).	
14. Tube (10).	Install on item (9).	
15. Tube (12).	Install on item (11).	
<b>NOTE</b>		
<b>Follow-on maintenance action required:</b>		
Close air system draincocks and start engine (TM 9-2320-283-10). Check air system for leaks (para 3-8).		
<b>3-1150</b>		

**BRAKE SYSTEM.**

**3-194. FIFTH WHEEL TOGGLE VALVE REPLACEMENT (Continued).**

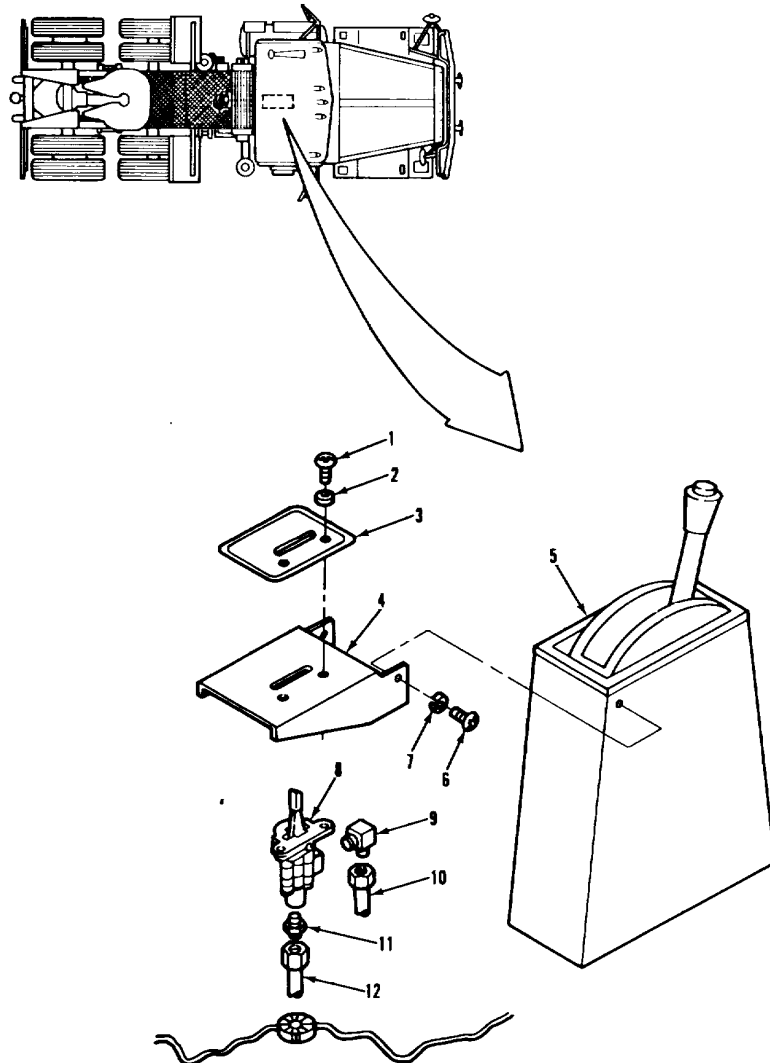

**LEGEND:**

- |  |                      |
|--|----------------------|
| 1. MACHINE SCREW (2)                                     | 6. SCREW (2)         |
| 2. FLAT WASHER (2)                                       | 7. LOCKWASHER (2)    |
| 3. CAB CONTROLLED FIFTH WHEEL<br>LOCKING POSITIONS DECAL | 8. TOGGLE VALVE      |
| 4. FIFTH WHEEL CONTROL BRACKET                           | 9. ELBOW             |
| 5. TRANSMISSION CONTROL MOUNTING<br>BRACKET ASSEMBLY     | 10. NONMETALLIC TUBE |
|  | 11. CONNECTOR        |
|  | 12. NONMETALLIC TUBE |

TA 237540

**BRAKE SYSTEM.**

**3-195. DIFFERENTIAL TOGGLE VALVE REPLACEMENT.**

THIS TASK COVERS

- a. Removal.
- b. Cleaning and Inspection.
- c. Installation.

INITIAL SETUP

<u>APPLICABLE CONFIGURATIONS</u> All.	<u>EQUIPMENT CONDITION PARAGRAPH</u> TM 9-2320-283-10.	<u>CONDITION DESCRIPTION</u> Air system draincocks opened.
<u>TEST EQUIPMENT</u> None.	3-114. removed.	Circuit breaker panel
<u>SPECIAL TOOLS</u> None.		
<u>MATERIALS/PARTS (P/N)</u> Tape, thread sealing Item 32, Appendix C. Solution, soap Item 28, Appendix C.		
<u>PERSONNEL REQUIRED</u> One (MOS-63S). dirt and dust.	<u>SPECIAL ENVIRONMENTAL CONDITIONS</u> Work area clean and away from blowing dirt and dust.	
<u>REFERENCES (TM)</u> TM 9-2320-283-10.	<u>GENERAL SAFETY INSTRUCTIONS</u> Engine off. Transmission in neutral. Park brake set.	
<u>TROUBLESHOOTING REFERENCES</u> Paragraph 2-11.		



BRAKE SYSTEM.

3-195. DIFFERENTIAL TOGGLE VALVE REPLACEMENT (Continued).

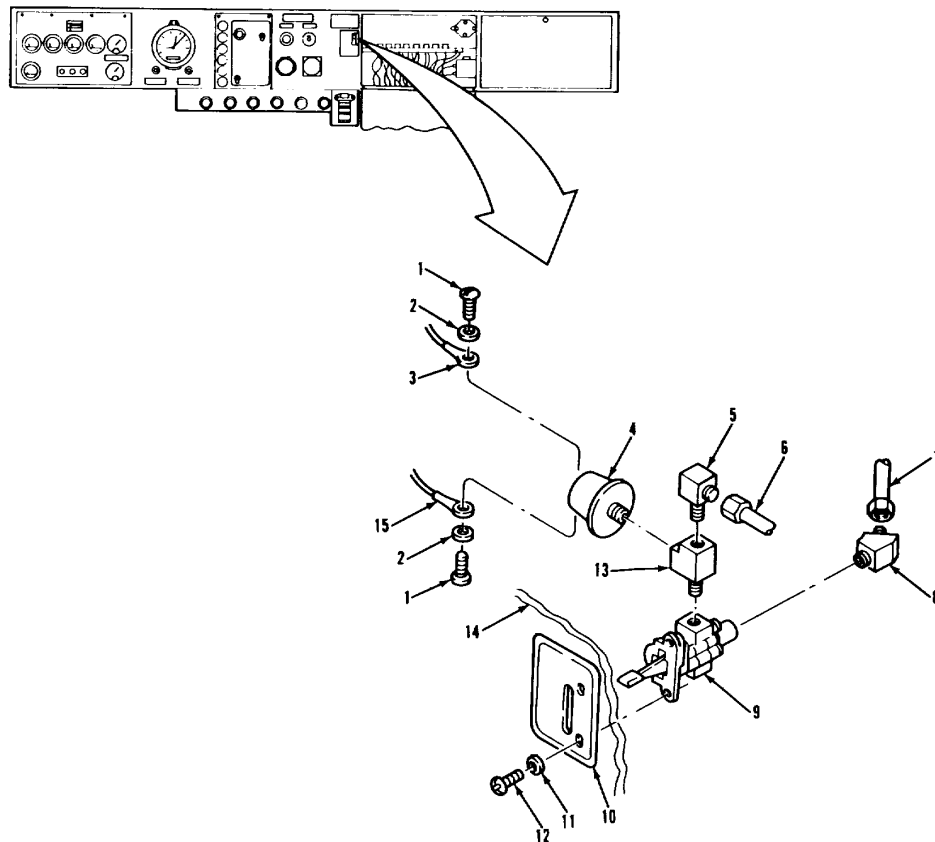

LEGEND:

- |                                      |  |
|--------------------------------------|--|
| 1. SCREW (2)                         | 9. TOGGLE VALVE                                    |
| 2. WASHER (2)                        | 10. INTERAXLE DIFFERENTIAL LOCKING POSITIONS DECAL |
| 3. WIRE (44G)                        | 11. FLAT WASHER (2)                                |
| 4. DIFFERENTIAL LOCK PRESSURE SWITCH | 12. MACHINE SCREW (2)                              |
| 5. ELBOW                             | 13. TEE  |
| 6. NONMETALLIC TUBE                  | 14. INSTRUMENT PANEL                               |
| 7. NONMETALLIC TUBE                  | 15. WIRE (53E)                                     |
| 8. ELBOW                             |  |

TA 237541

**BRAKE SYSTEM.****3-195. DIFFERENTIAL TOGGLE VALVE REPLACEMENT (Continued).**

LOCATION / ITEM	ACTION	REMARKS
<b>WARNING</b> <b>Never work on air system components without first draining air pressure. Failure to follow this precaution can result in serious personal injury.</b>		
A. <u>REMOVAL.</u>		
1. Tube (7).	Remove from item (8).	Tag for identification.
2. Tube (6).	Remove from item (5).	Tag for identification.
3. Two screws (12) and washers (11).	Remove from items (10) and (9).	
4. Valve (9) and decal (10).	a. Remove item (10) from item (14).	
	b. Remove item (9) from item (14) far enough to access item (4).	
5. Screw (1) and washer (2).	a. Remove from item (4).	
	b. Remove item (3) from item (4).	Tag for identification.
6. Screw (1) and washer (2).	a. Remove from item (4).	
b. Remove item (15) from item (4).	Tag for identification.	
c. Remove item (9) from item (14).		
7. Switch (4).	Remove from item (13).	
8. Elbow (5).	Remove from item (13).	
9. Tee (13).	Remove from item (9).	
10. Elbow (8).	Remove from item (9).	

**BRAKE SYSTEM.**

**3-195. DIFFERENTIAL TOGGLE VALVE REPLACEMENT (Continued).**

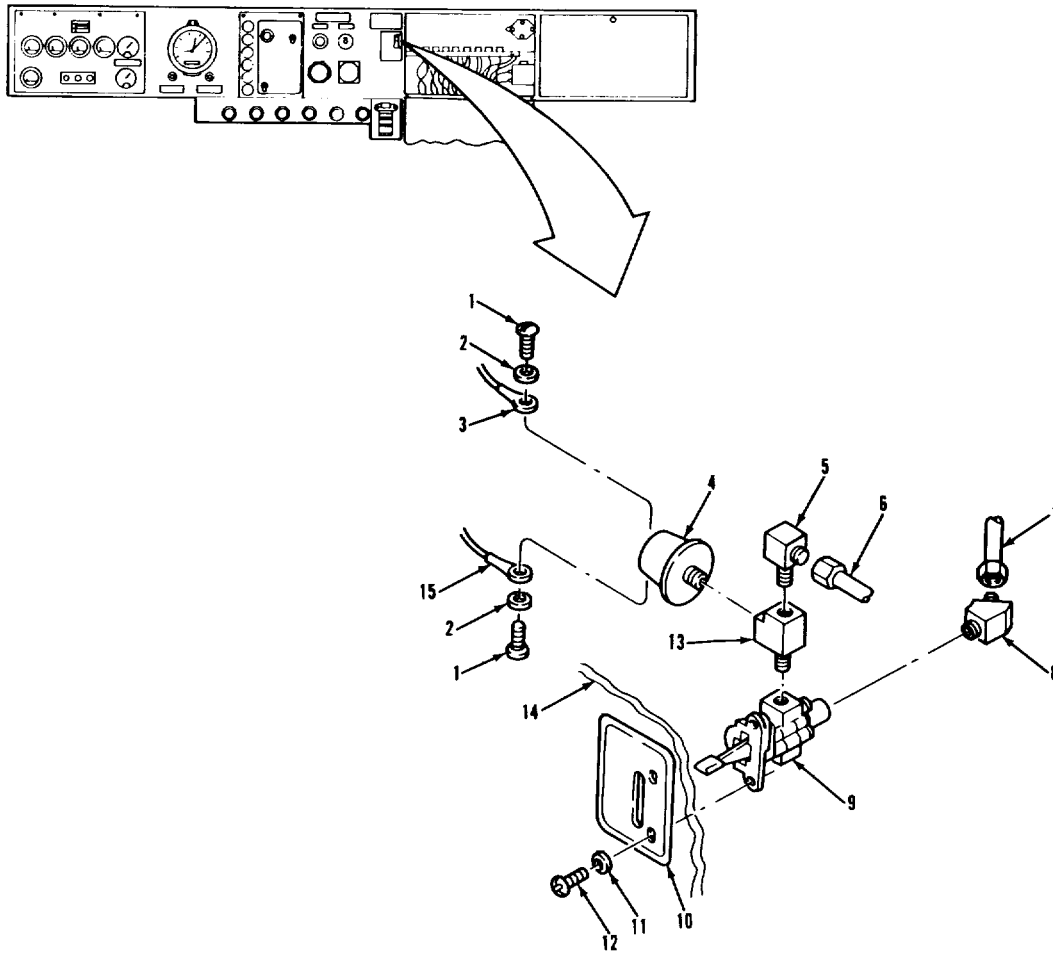

**LEGEND:**

- |    |                                   |     |  |
|----|-----------------------------------|-----|--|
| 1. | SCREW (2)                         | 9.  | TOGGLE VALVE                                   |
| 2. | WASHER (2)                        | 10. | INTERAXLE DIFFERENTIAL LOCKING POSITIONS DECAL |
| 3. | WIRE (44G)                        | 11. | FLAT WASHER (2)                                |
| 4. | DIFFERENTIAL LOCK PRESSURE SWITCH | 12. | MACHINE SCREW (2)                              |
| 5. | ELBOW                             | 13. | TEE  |
| 6. | NONMETALLIC TUBE                  | 14. | INSTRUMENT PANEL                               |
| 7. | NONMETALLIC TUBE                  | 15. | WIRE (53E)                                     |
| 8. | ELBOW                             |     |  |

TA 237542

**BRAKE SYSTEM.****3-195. DIFFERENTIAL TOGGLE VALVE REPLACEMENT (Continued).**

LOCATION / ITEM	ACTION	REMARKS
B. <u>CLEANING AND INSPECTION.</u>		
11. All metal parts.	Clean and inspect.	Refer to paragraphs 3-4 and 3-5.
C. <u>INSTALLATION.</u>		
12. Elbow (8). sealing tape.	a. Wrap threads with thread	Refer to paragraph 3-7.
	b. Install on item (9).	Point toward forward left side.
13. Tee (13).	a. Wrap threads with thread sealing tape.	Refer to paragraph 3-7.
	b. Install on item (9).	Point side port on item (13) toward left side.
14. Elbow (5).	a. Wrap threads with thread sealing tape.	
	b. Install on item (13).	Point toward right side.
15. Switch (4).	a. Wrap threads with thread sealing tape.	Refer to paragraph 3-7.
	b. Install on item (13).	
16. Wire (15).	a. Place in position on item (4).	
	b. Secure with item (1) and (2).	
17. Wire (3).	a. Place in position on item (4).	
	b. Secure with item (1) and (2).	

**BRAKE SYSTEM.**

**3-195. DIFFERENTIAL TOGGLE VALVE REPLACEMENT (Continued).**

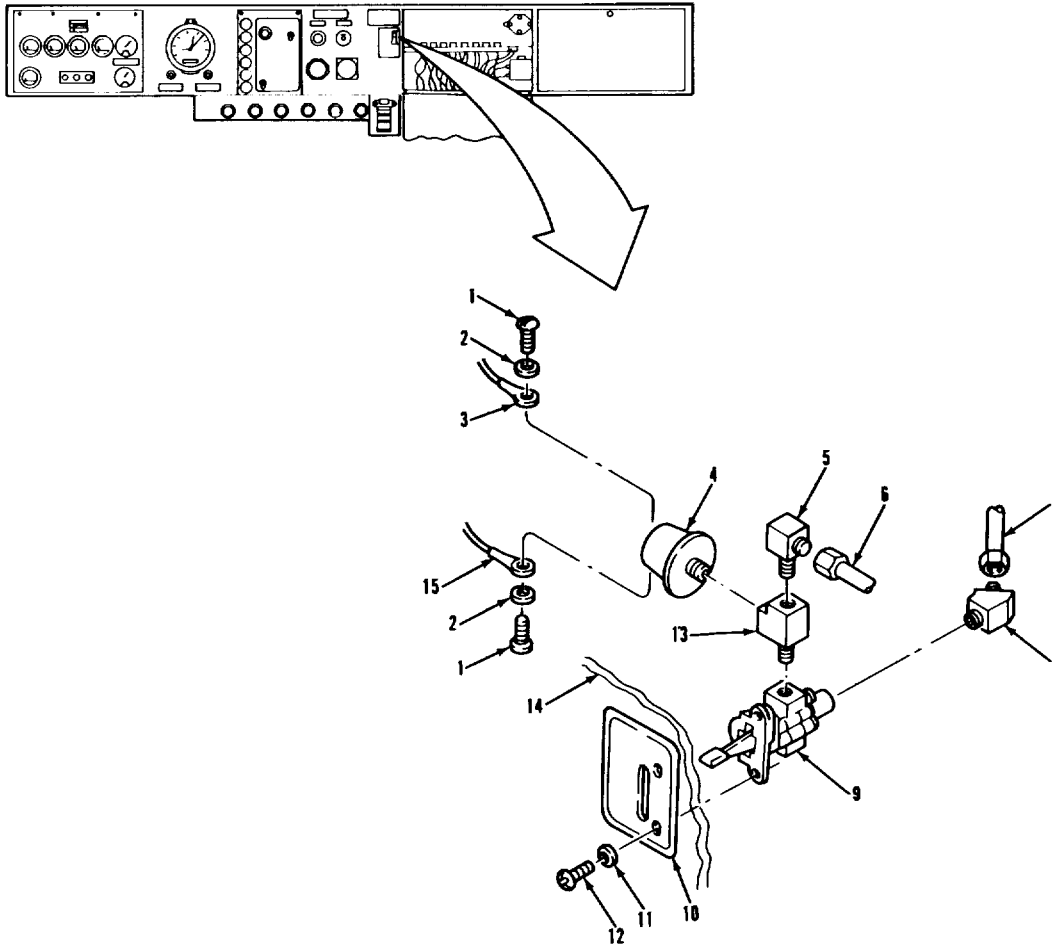

**LEGEND:**

- |                                      |  |
|--------------------------------------|--|
| 1. SCREW (2)                         | 9. TOGGLE VALVE                                    |
| 2. WASHER (2)                        | 10. INTERAXLE DIFFERENTIAL LOCKING POSITIONS DECAL |
| 3. WIRE (44G)                        | 11. FLAT WASHER (2)                                |
| 4. DIFFERENTIAL LOCK PRESSURE SWITCH | 12. MACHINE SCREW (2)                              |
| 5. ELBOW                             | 13. TEE  |
| 6. NONMETALLIC TUBE                  | 14. INSTRUMENT PANEL                               |
| 7. NONMETALLIC TUBE                  | 15. WIRE (53E)                                     |
| 8. ELBOW                             |  |

TA 237543

**BRAKE SYSTEM.****3-195. DIFFERENTIAL TOGGLE VALVE REPLACEMENT (Continued).**

LOCATION / ITEM	ACTION	REMARKS
-----------------	--------	---------

C. INSTALLATION (Continued).**CAUTION**

**Make sure that elbows and tees are not touching electrical connectors. Electrical shorts may result, damaging equipment.**

- |                                    |  |  |
|------------------------------------|--|--|
| 18. Valve (9) with attached parts. | a. Set in item (14).                     |  |
|                                    | b. Position item (10) against item (14). |  |
|                                    | c. Secure with two items (12) and (11).  |  |
| 19. Tube (6).                      | Install on item (5).                     |  |
| 20. Tube (7).                      | Install on item (8).                     |  |

**NOTE****Follow-on maintenance action required:**

Install circuit breaker bracket (para 3-114). Close air system draincocks and start engine (TM 9-2320-283-10). Check air system for leaks (para 3-8).

**BRAKE SYSTEM.**

**3-195. DIFFERENTIAL TOGGLE VALVE REPLACEMENT (Continued).**

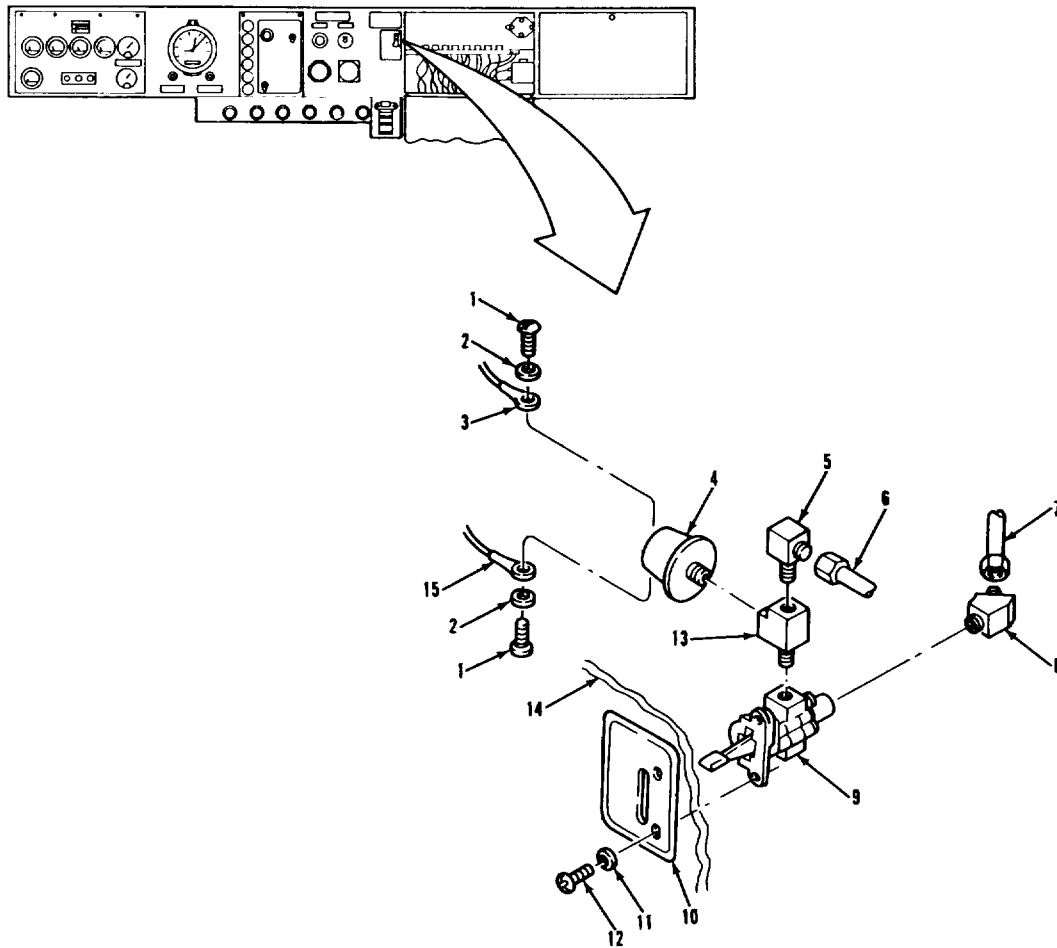

**LEGEND:**

- |                                      |  |
|--------------------------------------|--|
| 1. SCREW (2)                         | 9. TOGGLE VALVE                                    |
| 2. WASHER (2)                        | 10. INTERAXLE DIFFERENTIAL LOCKING POSITIONS DECAL |
| 3. WIRE (44G)                        | 11. FLAT WASHER (2)                                |
| 4. DIFFERENTIAL LOCK PRESSURE SWITCH | 12. MACHINE SCREW (2)                              |
| 5. ELBOW                             | 13. TEE  |
| 6. NONMETALLIC TUBE                  | 14. INSTRUMENT PANEL                               |
| 7. NONMETALLIC TUBE                  | 15. WIRE (53E)                                     |
| 8. ELBOW                             |  |

TA 237544

**BRAKE SYSTEM.**

**3-196. TRAILER COUPLINGS, BRACKETS, AND HOSE REPLACEMENT.**

THIS TASK COVERS

- a. Front Couplings and Hose Removal.
- b. Rear Couplings and Brackets Removal.
- c. Rear Couplings and Brackets Installation.
- d. Front Couplings and Hose Installation.

INITIAL SETUP

<u>APPLICABLE CONFIGURATIONS</u>	<u>EQUIPMENT CONDITION PARAGRAPH</u>	<u>CONDITION DESCRIPTION</u>
All.	TM 9-2320-283-10.	Air system draincocks open.

TEST EQUIPMENT  
None.

SPECIAL TOOLS  
None.

MATERIALS/PARTS (P/N)  
Tape, thread sealing  
Item 32, Appendix C.

PERSONNEL REQUIRED  
One (MOS-63S).

SPECIAL ENVIRONMENTAL CONDITIONS  
None.

REFERENCES (TM)  
TM 9-2320-283-10.

GENERAL SAFETY INSTRUCTIONS  
Engine off.  
Transmission in neutral.  
Park brake set.

TROUBLESHOOTING REFERENCES  
Paragraph 2-11.



**BRAKE SYSTEM.**

**3-196. TRAILER COUPLINGS, BRACKETS, AND HOSE REPLACEMENT (Continued).**

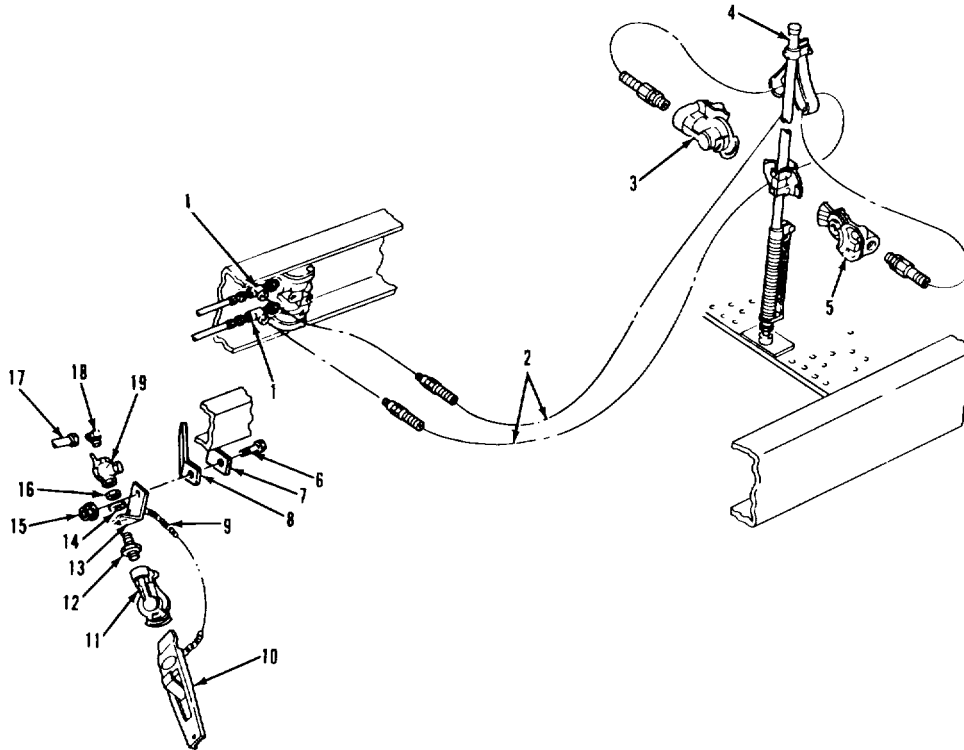

**LEGEND:**

- |   |                                      |
|---|--------------------------------------|
| 1. CONNECTOR (2)                              | 10. COUPLING ASSEMBLY                |
| 2. TRAILER SUPPLY AND EMERGENCY HOSE ASSEMBLY | 11. HOSE COUPLING (SERVICE)          |
| 3. HOSE COUPLING (EMERGENCY)                  | 12. BULKHEAD UNION                   |
| 4. HOSE TENDER                                | 13. RIGHT-HAND GLADHAND REAR BRACKET |
| 5. HOSE COUPLING (SERVICE)                    | 14. WASHER                           |
| 6. SCREW                                      | 15. NUT                              |
| 7. REAR CROSSMEMBER ASSEMBLY                  | 16. LOCKNUT                          |
| 8. BRACE                                      | 17. NONMETALLIC TUBE                 |
| 9. COUPLING CHAIN                             | 18. ELBOW                            |
|   | 19. CUTOUT COCK                      |

TA 237545

**BRAKE SYSTEM.****3-196. TRAILER COUPLINGS, BRACKETS, AND HOSE REPLACEMENT (Continued).**

LOCATION / ITEM	ACTION	REMARKS
-----------------	--------	---------

**WARNING**

**Never work on air system components without first draining air pressure. Failure to follow this precaution can result in serious personal injury.**

**A. FRONT COUPLINGS AND HOSE REMOVAL.**

- |                                   |  |  |
|-----------------------------------|--|--|
| 1. Hose assembly (2).             | Remove from two items (1).                               |  |
| 2. Coupling (3) and coupling (5). | a. Remove from item (4).<br><br>b. Remove from item (2). |  |
| 3. Hose assembly (2).             | Remove from item (4).                                    |  |

**B. REAR COUPLINGS AND BRACKETS REMOVAL.****NOTE**

**Removal of the two rear trailer couplings and brackets is similar. Removal of right (service) is shown. Left (emergency) has a male connector in place of elbow (18).**

- |   |  |             |
|---|--|-------------|
| 4. Tube (17).                                 | Remove from item (18).                         |             |
| 5. Screw (6) and nut (15).                    | Remove from item (7), item (8), and item (13). |             |
| 6. Chain (9).                                 | Unhook from item (13).                         | Use pliers. |
| 7. Coupling assembly (10).                    | Remove from item (11).                         |             |
| 8. Coupling (11).                             | Remove from item (12).                         |             |
| 9. Elbow (18) (on left side, male connector). | Remove from item (19).                         |             |

**BRAKE SYSTEM.**

**3-196. TRAILER COUPLINGS, BRACKETS, AND HOSE REPLACEMENT (Continued).**

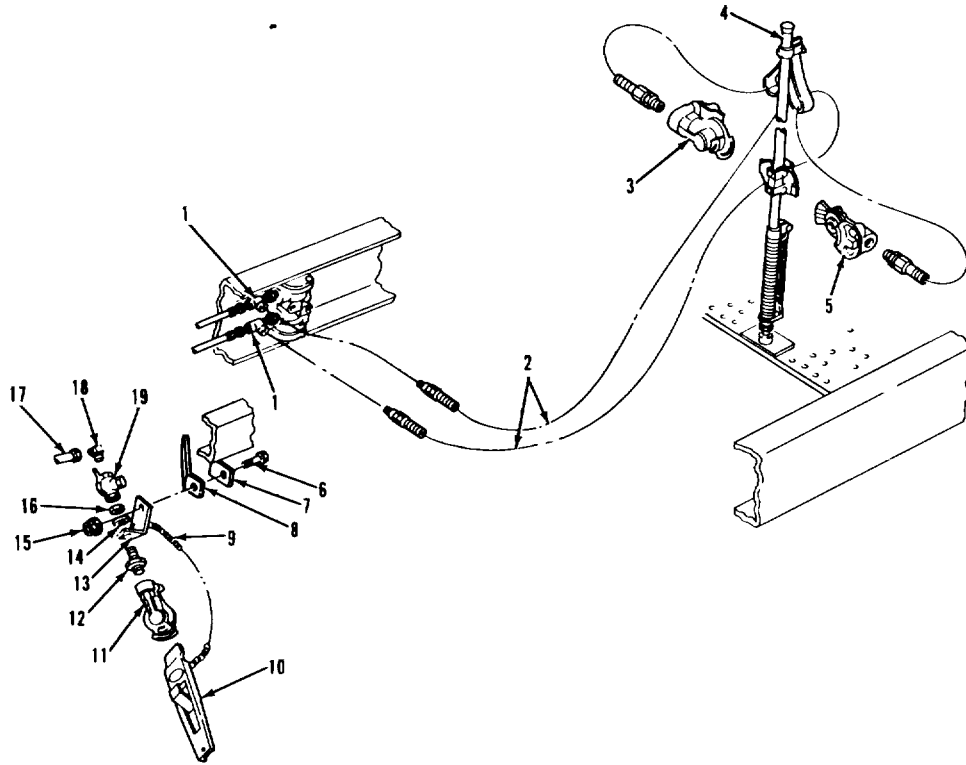

**LEGEND:**

- |   |                                      |
|---|--------------------------------------|
| 1. CONNECTOR (2)                              | 10. COUPLING ASSEMBLY                |
| 2. TRAILER SUPPLY AND EMERGENCY HOSE ASSEMBLY | 11. HOSE COUPLING (SERVICE)          |
| 3. HOSE COUPLING (EMERGENCY)                  | 12. BULKHEAD UNION                   |
| 4. HOSE TENDER                                | 13. RIGHT-HAND GLADHAND REAR BRACKET |
| 5. HOSE COUPLING (SERVICE)                    | 14. WASHER                           |
| 6. SCREW                                      | 15. NUT                              |
| 7. REAR CROSSMEMBER ASSEMBLY                  | 16. LOCKNUT                          |
| 8. BRACE                                      | 17. NONMETALLIC TUBE                 |
| 9. COUPLING CHAIN                             | 18. ELBOW                            |
|   | 19. CUTOUT COCK                      |

TA 237546

**BRAKE SYSTEM.****3-196. TRAILER COUPLINGS, BRACKETS, AND HOSE REPLACEMENT (Continued).**

LOCATION / ITEM	ACTION	REMARKS
B. <u>REAR COUPLINGS AND BRACKETS REMOVAL (Continued).</u>		
10. Cock (19).	Remove from item (12).	
11. Locknut (16) and washer (14).	Remove from item (12).	
12. Union (12).	Remove from item (13).	
C. <u>REAR COUPLINGS AND BRACKETS INSTALLATION.</u>		
13. Union (12).	Put in place in item (13).	
14. Locknut (16) and washer (14).	Secure item (12) to item (13).	
15. Cock (19).	Install on item (12).	Put thread sealing tape on threads.
16. Elbow (18) (on left side, male connector).	Install in item (19).	Put thread sealing tape on threads.
17. Coupling (11).	Install on item (12).	Put thread sealing tape on threads.
18. Coupling assembly (10).	Install on item (11).	
19. Chain (9).	Hook to item (13).	Use pliers.
20. Screw (6) and nut (15).	Secure item (13) and item (8) to item (7).	
21. Tube (17).	Install on item (18).	

**BRAKE SYSTEM.**

**3-196. TRAILER COUPLINGS, BRACKETS, AND HOSE REPLACEMENT (Continued).**

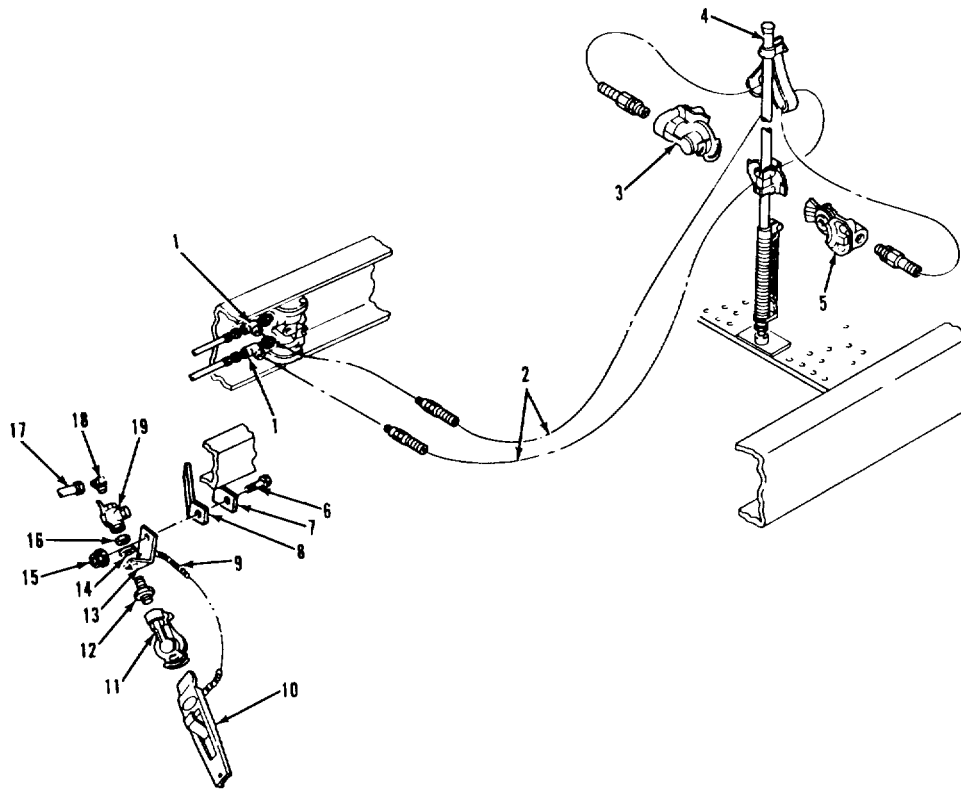

**LEGEND:**

- |   |                                      |
|---|--------------------------------------|
| 1. CONNECTOR (2)                              | 10. COUPLING ASSEMBLY                |
| 2. TRAILER SUPPLY AND EMERGENCY HOSE ASSEMBLY | 11. HOSE COUPLING (SERVICE)          |
| 3. HOSE COUPLING (EMERGENCY)                  | 12. BULKHEAD UNION                   |
| 4. HOSE TENDER                                | 13. RIGHT-HAND GLADHAND REAR BRACKET |
| 5. HOSE COUPLING (SERVICE)                    | 14. WASHER                           |
| 6. SCREW                                      | 15. NUT                              |
| 7. REAR CROSSMEMBER ASSEMBLY                  | 16. LOCKNUT                          |
| 8. BRACE                                      | 17. NONMETALLIC TUBE                 |
| 9. COUPLING CHAIN                             | 18. ELBOW                            |
|   | 19. CUTOUT COCK                      |

TA 237547

**BRAKE SYSTEM.****3-196. TRAILER COUPLINGS, BRACKETS, AND HOSE REPLACEMENT (Continued).**

LOCATION / ITEM	ACTION	REMARKS
D. FRONT COUPLINGS AND HOSE INSTALLATION.		
22. Hose assembly (2).	Put through loops on item (4).	
23. Coupling (3) and coupling (5).	a. Install on item (2). on threads.	Put thread sealing tape Item (5) goes on blue hose.
	b. Install on item (4).	
24. Hose assembly (2).	Install on two items (1).	Blue hose goes on bottom.

**NOTE**

**Follow-on maintenance action required: Close air system draincocks and start engine (TM 9-2320-283-10). Check air system for leaks (para 3-8).**

**BRAKE SYSTEM.**

**3-196. TRAILER COUPLINGS, BRACKETS, AND HOSE REPLACEMENT (Continued).**

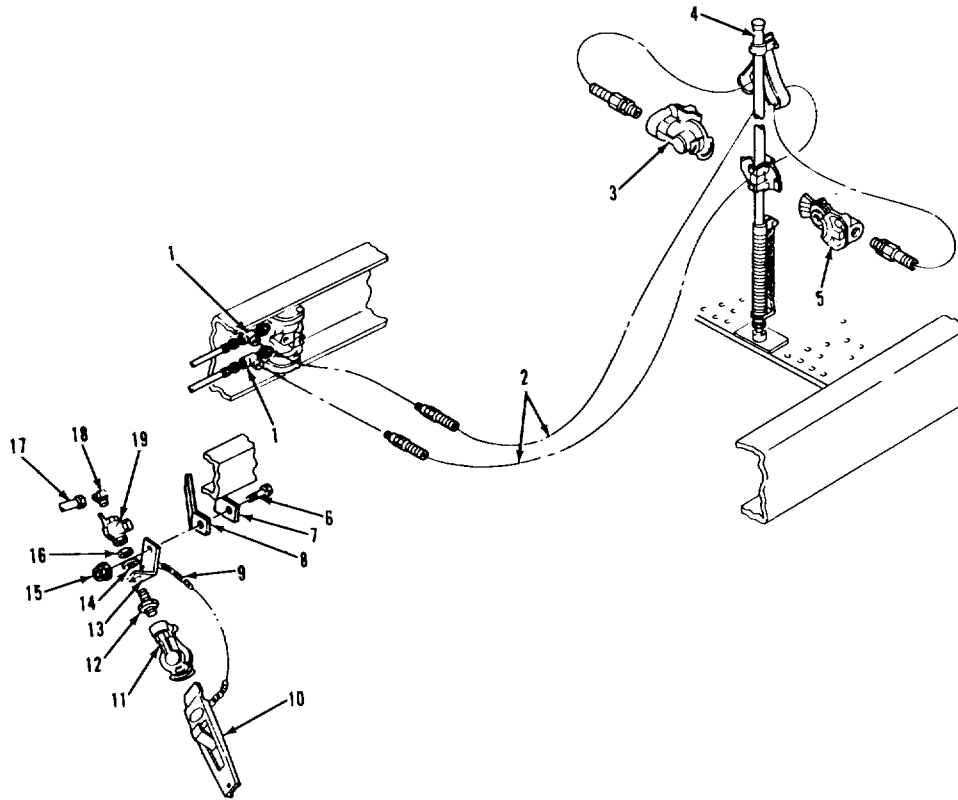

**LEGEND:**

- |   |                                      |
|---|--------------------------------------|
| 1. CONNECTOR (2)                              | 10. COUPLING ASSEMBLY                |
| 2. TRAILER SUPPLY AND EMERGENCY HOSE ASSEMBLY | 11. HOSE COUPLING (SERVICE)          |
| 3. HOSE COUPLING (EMERGENCY)                  | 12. BULKHEAD UNION                   |
| 4. HOSE TENDER                                | 13. RIGHT-HAND GLADHAND REAR BRACKET |
| 5. HOSE COUPLING (SERVICE)                    | 14. WASHER                           |
| 6. SCREW                                      | 15. NUT                              |
| 7. REAR CROSSMEMBER ASSEMBLY                  | 16. LOCKNUT                          |
| 8. BRACE                                      | 17. NONMETALLIC TUBE                 |
| 9. COUPLING CHAIN                             | 18. ELBOW                            |
|   | 19. CUTOUT COCK                      |

TA 237548

**BRAKE SYSTEM.**

**3-197. HOSE TENDER REPLACEMENT.**

THIS TASK COVERS

- a. Removal.
- b. Installation.

INITIAL SETUP

APPLICABLE CONFIGURATIONS

All.

EQUIPMENT CONDITION  
PARAGRAPH

3-198.

CONDITION DESCRIPTION

Front trailer couplings  
and hose removed.

TEST EQUIPMENT

None.

SPECIAL TOOLS

None.

MATERIALS/PARTS (P/N)

None.

PERSONNEL REQUIRED

One (MOS-63S).

SPECIAL ENVIRONMENTAL CONDITIONS

None.

REFERENCES (TM)

TM 9-2320-283-10.

GENERAL SAFETY INSTRUCTIONS

Engine off.  
Transmission in neutral.  
Park brake set.

TROUBLESHOOTING REFERENCES

None.



**BRAKE SYSTEM.**

**3-197. HOSE TENDER REPLACEMENT (Continued).**

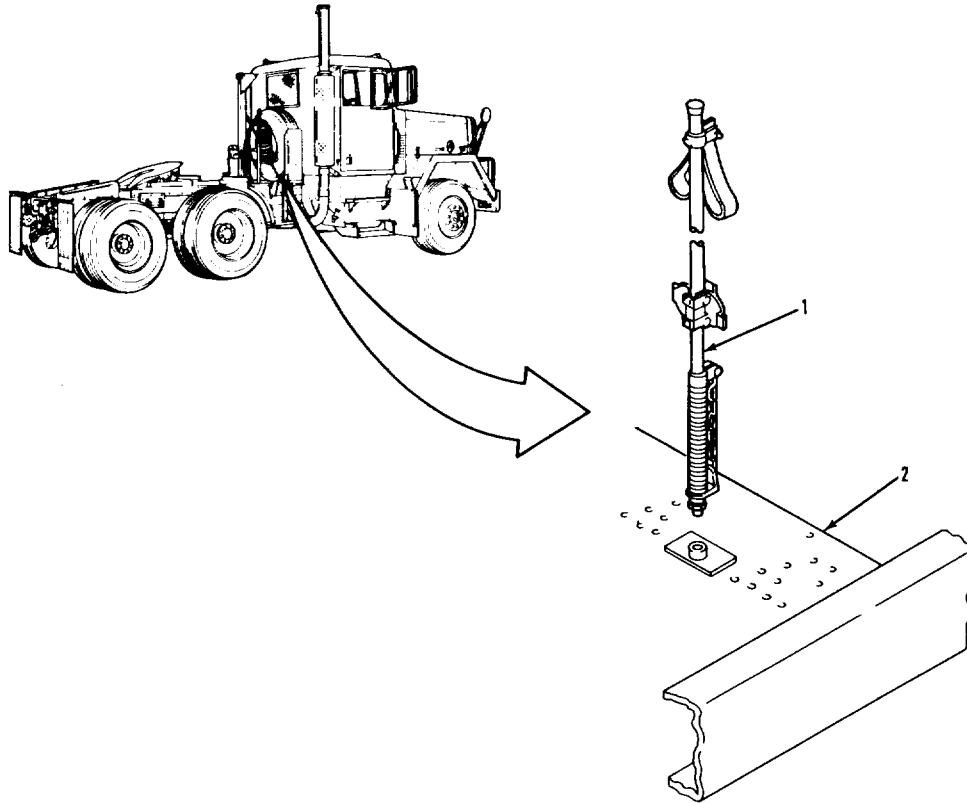

**LEGEND:**

- 1. HOSE TENDER
- 2. SERVICE DECK HALF WITH POGO PLATE

TA 237549

**BRAKE SYSTEM.****3-197. HOSE TENDER REPLACEMENT (Continued).**

<b>LOCATION / ITEM</b>	<b>ACTION</b>	<b>REMARKS</b>
1. A. REMOVAL. Tender (1).	Remove from item (2).	Use a wrench on nut at bottom of item (1).
2. B. INSTALLATION. Tender (1).	Install in item (2).	Use a wrench on nut at bottom of item (1).

**NOTE****Follow-on maintenance action required:****Install front trailer couplings and hose (para 3-198).**

3-1170

**BRAKE SYSTEM.**

**3-197. HOSE TENDER REPLACEMENT (Continued).**

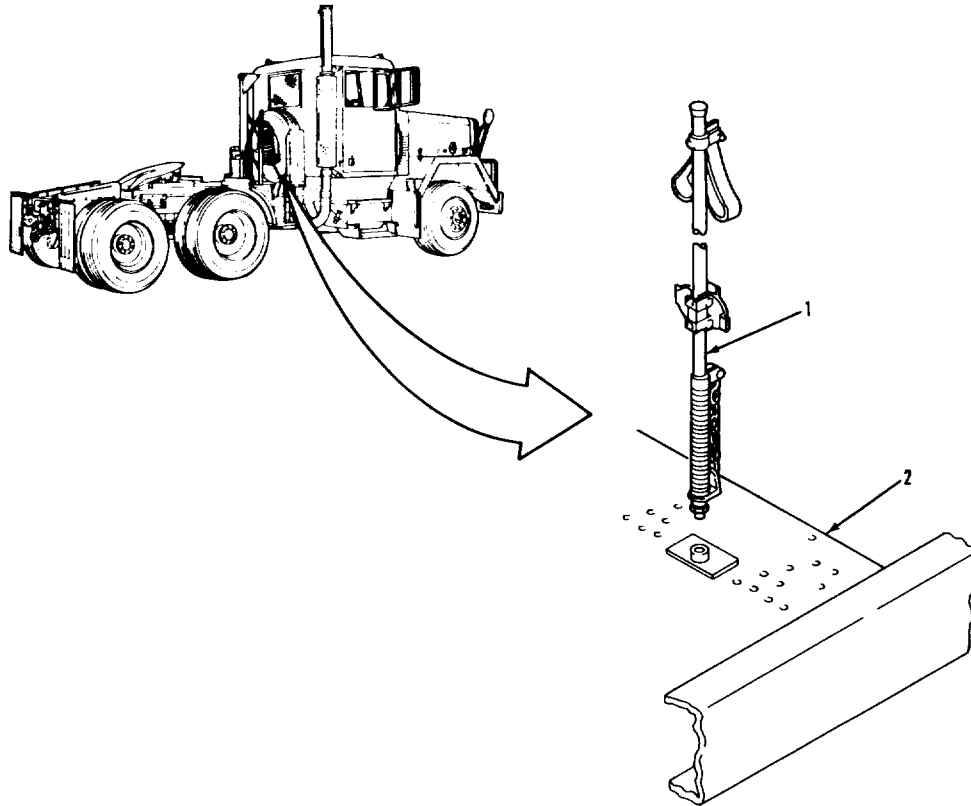

**LEGEND:**

- 1. HOSE TENDER
- 2. SERVICE DECK HALF WITH POGO PLATE

TA 237550

THIS TASK COVERS

- a. Removal.
- b. Cleaning and Inspection.
- c. Installation.
- d. Operational Checkout.

INITIAL SETUP

<u>APPLICABLE CONFIGURATIONS</u>	<u>EQUIPMENT CONDITION PARAGRAPH</u>	<u>CONDITION DESCRIPTION</u>
All.	TM 9-2320-283-10.	Air system draincocks opened.

TEST EQUIPMENT  
None.

SPECIAL TOOLS  
None.

MATERIALS/PARTS (P/N)  
Tape, thread sealing  
Item 32, Appendix C.

<u>PERSONNEL REQUIRED</u>	<u>SPECIAL ENVIRONMENTAL CONDITIONS</u>
One (MOS-63S).	Work area clean and away from blowing dirt and dust.

<u>REFERENCES (TM)</u>	<u>GENERAL SAFETY INSTRUCTIONS</u>
TM 9-2320-2 3-10.	Vehicle on level ground. Wheels blocked. Engine off.

<u>TROUBLESHOOTING REFERENCES</u>	Transmission in neutral.
Paragraph 2-11.	

**BRAKE SYSTEM.**

**3-198. AIR DRYER REPLACEMENT (Continued).**

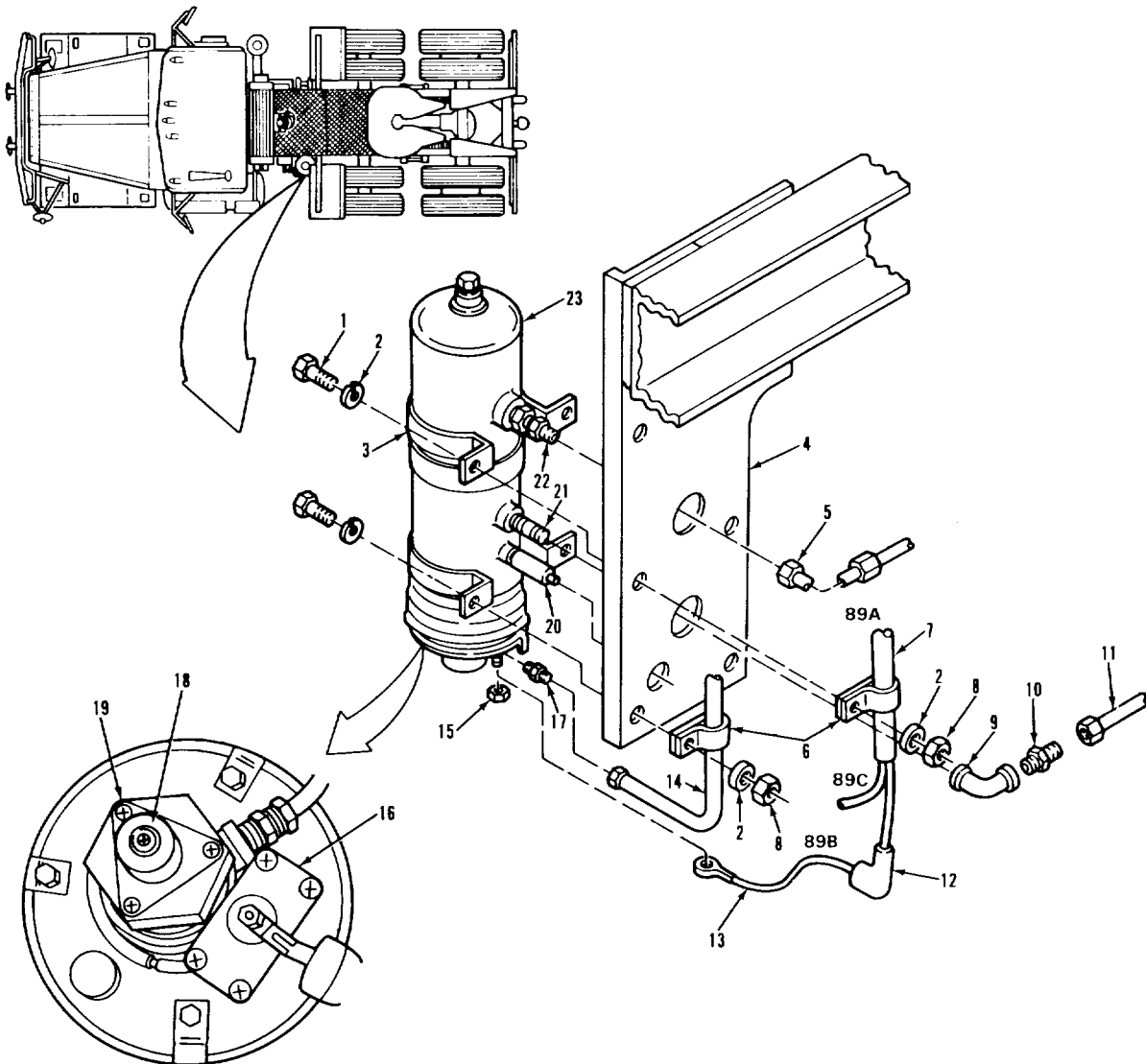

**LEGEND:**

- |                               |  |
|-------------------------------|--|
| 1. HEXAGON HEAD SCREW (4)     | 13. HEATER CONTROL WIRE                                  |
| 2. PLAIN WASHER (8)           | 14. HOSE ASSEMBLY  |
| 3. MOUNTING BRACKET (2)       | 15. HEXAGON NUT  |
| 4. AIR DRYER MOUNTING BRACKET | 16. ELECTRICAL TERMINAL (HEATER AND THERMOSTAT ASSEMBLY) |
| 5. AIR DRYER HOSE ASSEMBLY    | 17. CONNECTOR  |
| 6. LOOP CLAMP (2)             | 18. EXHAUST COVER  |
| 7. ELECTRICAL CABLE           | 19. END COVER ASSEMBLY                                   |
| 8. HEXAGON NUT (4)            | 20. SAFETY VALVE   |
| 9. ELBOW                      | 21. NIPPLE   |
| 10. CONNECTOR                 | 22. CONNECTOR  |
| 11. TUBE ASSEMBLY             | 23. AIR DRYER ASSEMBLY                                   |
| 12. INSULATING BOOT           |  |

TA 237551

**BRAKE SYSTEM.****3-198. AIR DRYER REPLACEMENT (Continued).**

LOCATION / ITEM	ACTION	REMARKS
A. <u>REMOVAL.</u>		
1. Hose assembly (5).	Disconnect from item (22).	
2. Tube assembly (11).	Disconnect from item (10).	
3. Connector (10).	Disconnect from item (9).	
4. Elbow (9).	Disconnect from item (21).	
5. Hose assembly (14).	Disconnect from item (17).	
6. Boot (12), wire (13), and nut (15).	Remove from item (16).	
7. Four screws (1), eight washers (2), and four nuts (8), clamp (6) with hose assembly (14), clamp (6) with cable (7), and dryer assembly (23).	Remove from item (4).	
B. <u>CLEANING AND INSPECTION.</u>		
8. All parts.	Clean and inspect.	Refer to paragraphs 3-4 and 3-5.

**BRAKE SYSTEM.**

**3-198. AIR DRYER REPLACEMENT (Continued).**

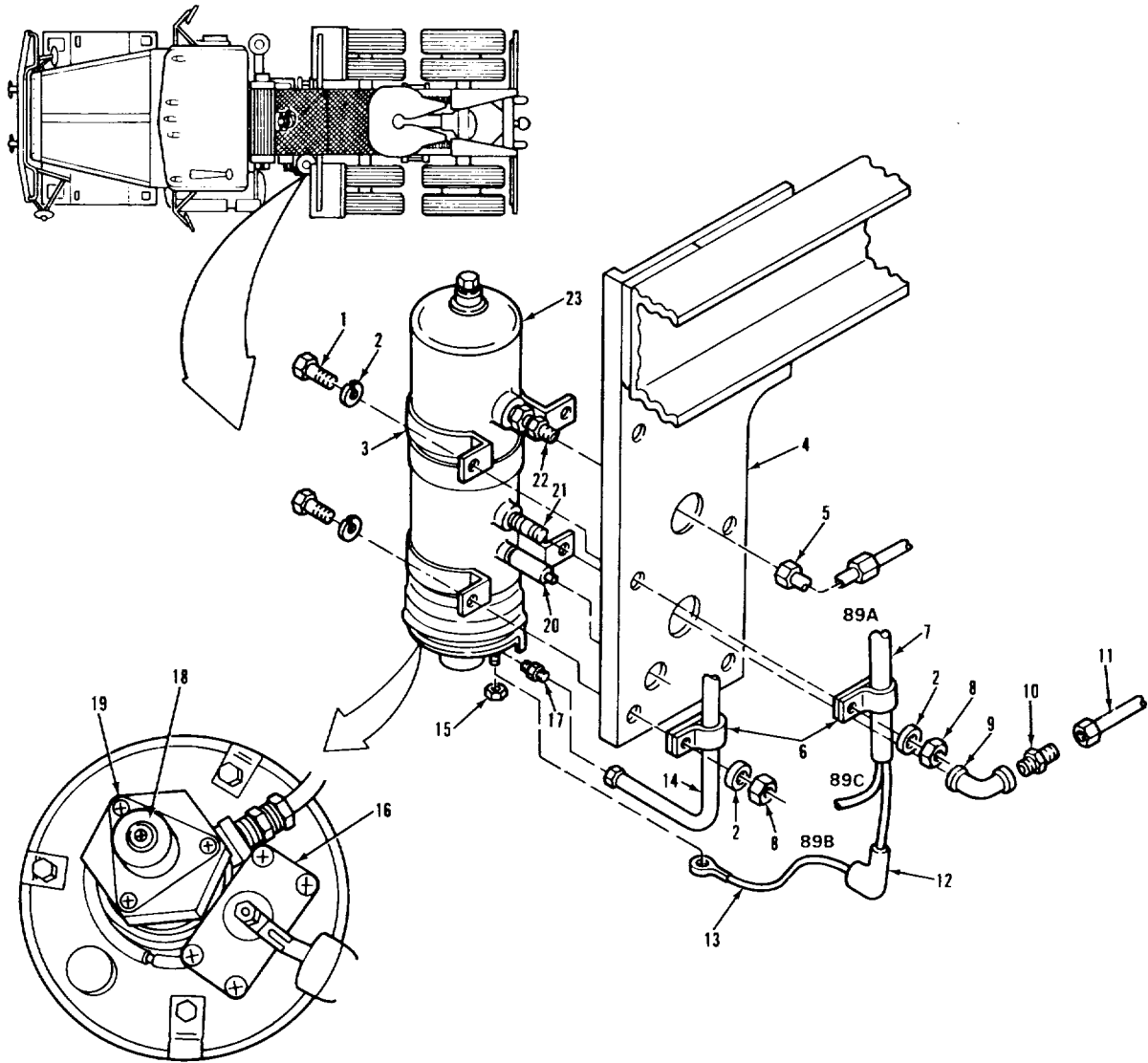

**LEGEND:**

- |                               |  |
|-------------------------------|--|
| 1. HEXAGON HEAD SCREW (4)     | 13. HEATER CONTROL WIRE                                  |
| 2. PLAIN WASHER (8)           | 14. HOSE ASSEMBLY  |
| 3. MOUNTING BRACKET (2)       | 15. HEXAGON NUT  |
| 4. AIR DRYER MOUNTING BRACKET | 16. ELECTRICAL TERMINAL (HEATER AND THERMOSTAT ASSEMBLY) |
| 5. AIR DRYER HOSE ASSEMBLY    | 17. CONNECTOR  |
| 6. LOOP CLAMP (2)             | 18. EXHAUST COVER  |
| 7. ELECTRICAL CABLE           | 19. END COVER ASSEMBLY                                   |
| 8. HEXAGON NUT (4)            | 20. SAFETY VALVE   |
| 9. ELBOW                      | 21. NIPPLE   |
| 10. CONNECTOR                 | 22. CONNECTOR  |
| 11. TUBE ASSEMBLY             | 23. AIR DRYER ASSEMBLY                                   |
| 12. INSULATING BOOT           |  |

**BRAKE SYSTEM.****3-198. AIR DRYER REPLACEMENT (Continued).**

LOCATION / ITEM	ACTION	REMARKS
C. <u>INSIALLATION.</u>		
9. Dryer assembly (23), clamp (6) with hose assembly (14), and clamp (6) with cable (7).	a. Place in position on item (4).  b. Secure in place with four items (1), eight items (2), and four items (8).	Ensure item (20) is centered in mounting hole.
<p><b>NOTE</b>  <b>If air dryer was recently repaired, a new boot may be provided. If it is, discard old boot and install new boot on heater control wire.</b></p>		
10. Wire (13), boot (12), and nut (15).	Install on item (16).	
11. Hose assembly (14).	Install on item (17).	
12. Elbow (9).	Apply thread sealer and install on item (21).	Use thread sealing tape.
13. Connector (10).	Apply thread sealer and install in item (9).	Use thread sealing tape.
14. Tube assembly (11).	Install on item (10).	
15. Hose (5).	Apply thread sealer and install on item (22).	Use thread sealing tape.



**BRAKE SYSTEM.**

**3-198. AIR DRYER REPLACEMENT (Continued).**

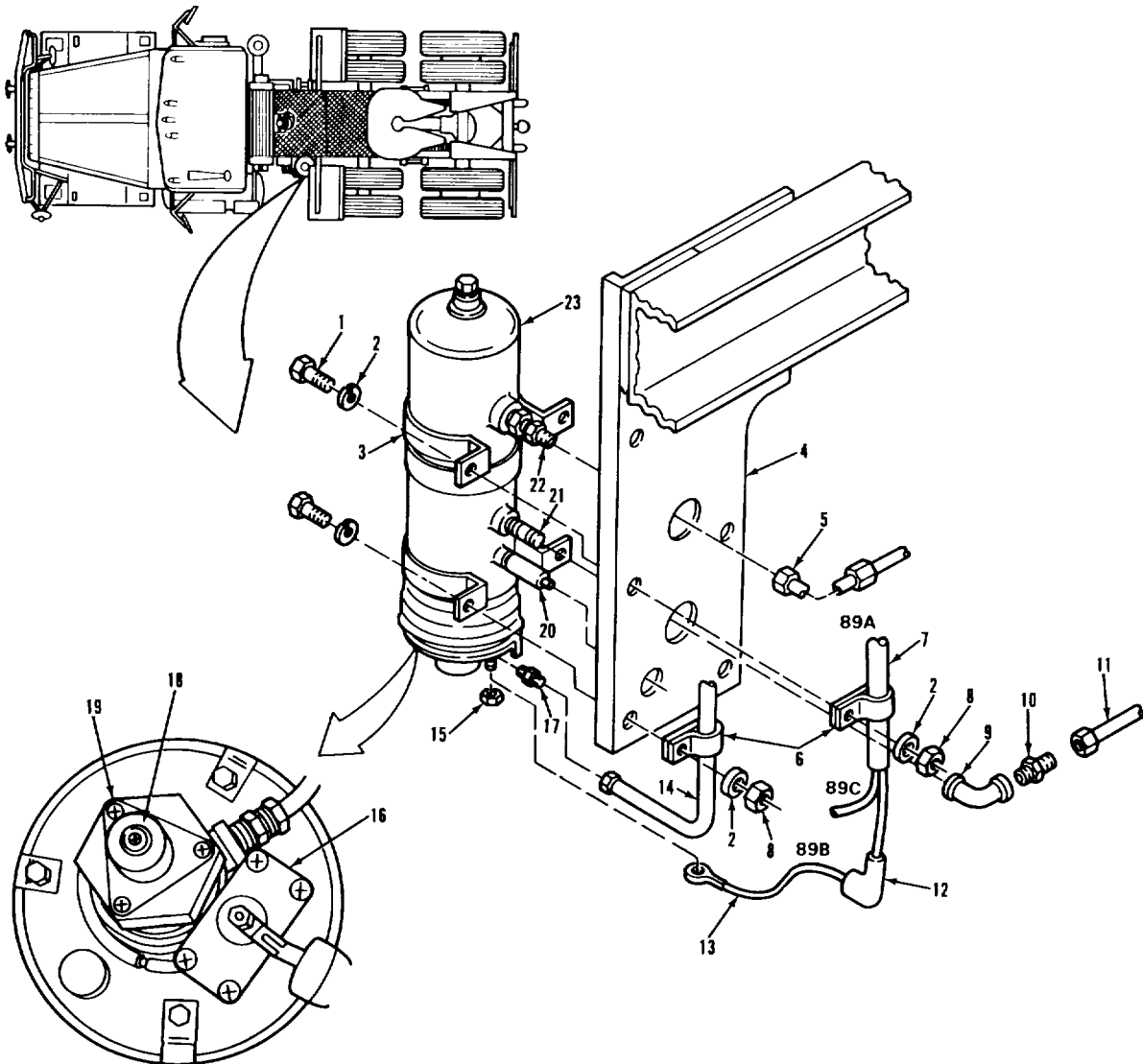

**LEGEND:**

- |                               |  |
|-------------------------------|--|
| 1. HEXAGON HEAD SCREW (4)     | 13. HEATER CONTROL WIRE                                  |
| 2. PLAIN WASHER (8)           | 14. HOSE ASSEMBLY  |
| 3. MOUNTING BRACKET (2)       | 15. HEXAGON NUT  |
| 4. AIR DRYER MOUNTING BRACKET | 16. ELECTRICAL TERMINAL (HEATER AND THERMOSTAT ASSEMBLY) |
| 5. AIR DRYER HOSE ASSEMBLY    | 17. CONNECTOR  |
| 6. LOOP CLAMP (2)             | 18. EXHAUST COVER  |
| 7. ELECTRICAL CABLE           | 19. END COVER ASSEMBLY                                   |
| 8. HEXAGON NUT (4)            | 20. SAFETY VALVE   |
| 9. ELBOW,                     | 21. NIPPLE   |
| 10. CONNECTOR                 | 22. CONNECTOR  |
| 11. TUBE ASSEMBLY             | 23. AIR DRYER ASSEMBLY                                   |
| 12. INSULATING BOOT           |  |

**BRAKE SYSTEM.**

**3-198. AIR DRYER REPLACEMENT (Continued).**

LOCATION / ITEM	ACTION	REMARKS
-----------------	--------	---------

D. OPERATIONAL CHECK.

**WARNING**

**Ensure that, when engine is running, wheels are blocked, transmission is set to neutral, and vehicle is secured. Failure to secure vehicle could cause injury or death to persons working in and around vehicle.**

16. Engine.	<ul style="list-style-type: none"> <li>a. Close air system drain-cocks. Start up and charge air system until air pressure reaches 100 psi. Verify that there is no air leakage at cover (18) or at any air line connections.</li> <li>b. Charge the system until the compressor unloads. Verify that system purges.</li> </ul>	<p>Refer to TM 9-2320-283-10.</p> <p>A sharp burst of air should exhaust from item (18).</p>
-------------	--	--

**NOTE**

**For the next step, thermostat assembly should be exposed to temperatures below 50°F.**

17. Cover (19).	<ul style="list-style-type: none"> <li>a. Having run engine for a minimum of five minutes, verify that heating element is working.</li> <li>b. Shut down engine.</li> </ul>	<p>Item (19) should be warm. If not, item (19) should be replaced. (Refer to para 3-199).</p> <p>Refer to TM 9-2320-283-10.</p>
-----------------	---	---

**NOTE**

**Follow-on maintenance action required:**  
None.

**BRAKE SYSTEM.**

**3-198. AIR DRYER REPLACEMENT (Continued).**

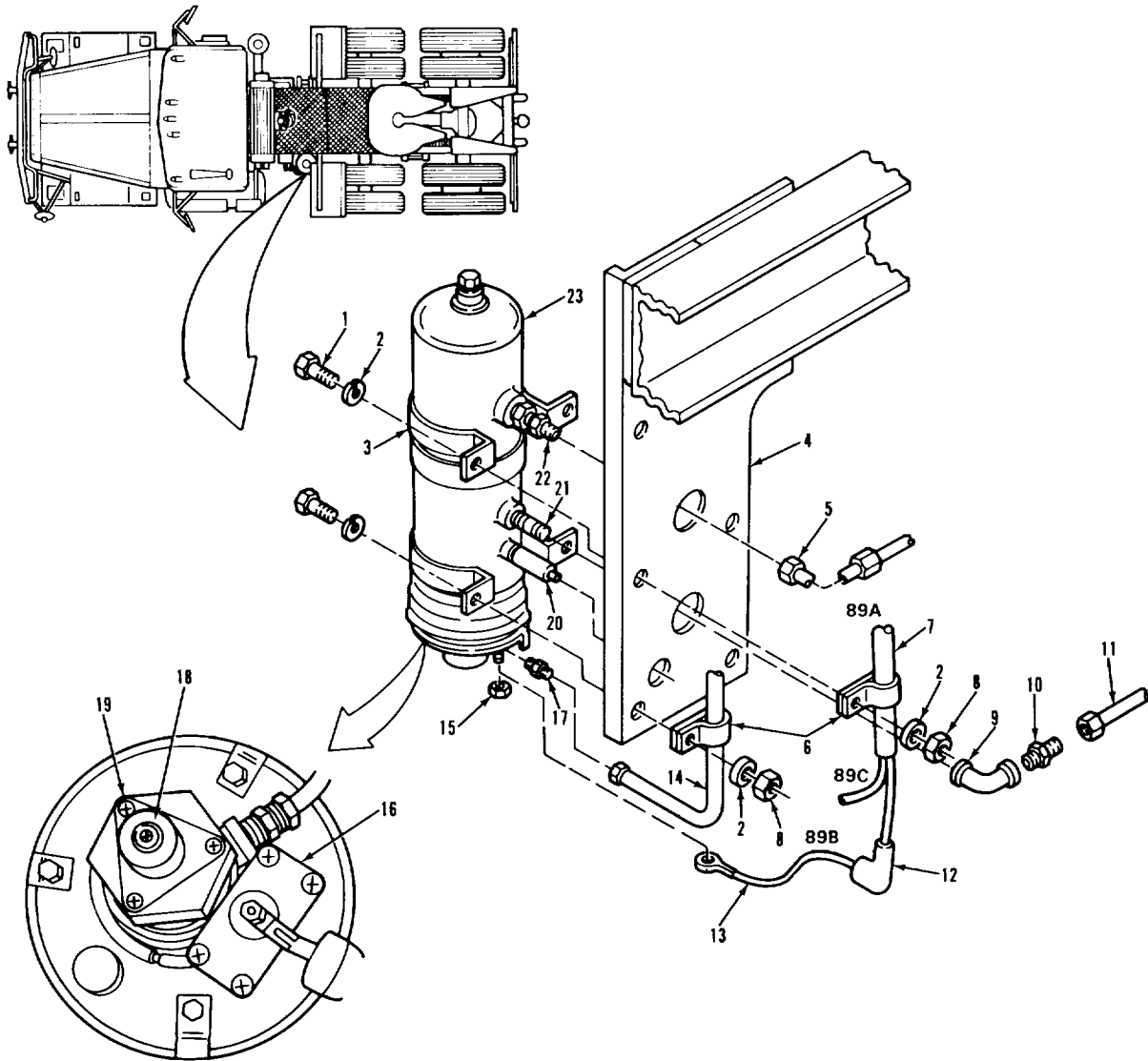

**LEGEND:**

- |                               |  |
|-------------------------------|--|
| 1. HEXAGON HEAD SCREW (4)     | 13. HEATER CONTROL WIRE                                  |
| 2. PLAIN WASHER (8)           | 14. HOSE ASSEMBLY  |
| 3. MOUNTING BRACKET (2)       | 15. HEXAGON NUT  |
| 4. AIR DRYER MOUNTING BRACKET | 16. ELECTRICAL TERMINAL (HEATER AND THERMOSTAT ASSEMBLY) |
| 5. AIR DRYER HOSE ASSEMBLY    | 17. CONNECTOR  |
| 6. LOOP CLAMP (2)             | 18. EXHAUST COVER  |
| 7. ELECTRICAL CABLE           | 19. END COVER ASSEMBLY                                   |
| 8. HEXAGON NUT (4)            | 20. SAFETY VALVE   |
| 9. ELBOW                      | 21. NIPPLE   |
| 10. CONNECTOR                 | 22. CONNECTOR  |
| 11. TUBE ASSEMBLY             | 23. AIR DRYER ASSEMBLY                                   |
| 12. INSULATING BOOT           |  |

**BRAKE SYSTEM.**

**3-199. AIR DRYER REPAIR.**

THIS TASK COVERS

- |                 |              |
|-----------------|--------------|
| a. Disassembly. | d. Repair.   |
| b. Cleaning.    | e. Assembly. |
| c. Inspection.  |              |

INITIAL SETUP

<u>APPLICABLE CONFIGURATIONS</u>	<u>EQUIPMENT CONDITION PARAGRAPH</u>	<u>CONDITION DESCRIPTION</u>
All.	3-200.	Air dryer removed.

TEST EQUIPMENT

None.

SPECIAL TOOLS

None.

MATERIALS/PARTS (P/N)

Grease, silicone, lubrication Item 9, Appendix C.	Kit, seal (06853) 287053.
Tape, thread sealing Item 32, Appendix C.	Dehydrate cartridge assembly (06853) 286968.
Kit, check valve repair (06853) 287298.	

PERSONNEL REQUIRED

One (MOS-63S).

SPECIAL ENVIRONMENTAL CONDITIONS

Work area clean and away from blowing dirt and dust.

REFERENCES (TM)

TM 9-2320-283-20P.

GENERAL SAFETY INSTRUCTIONS

None.

TROUBLESHOOTING REFERENCES

Paragraph 2-11.

**BRAKE SYSTEM.****3-199. AIR DRYER REPAIR (Continued).**

## LEGEND:

1. PIPE PLUG (2)	15. DEHYDRATE CARTRIDGE	30. SCREW
2. AIR DRYER HOUSING	16. O-RING	31. DIAPHRAGM WASHER
3. CHECK VALVE	17. END COVER ASSEMBLY	32. EXHAUST DIAPHRAGM
4. END CAP	18. PURGE VALVE ASSEMBLY	33. BOOT
5. BALL	19. O-RING	34. ELECTRICAL TERMINAL
6. SPRING	20. PURGE VALVE PISTON	35. END COVER HOUSING
7. SPRING GUIDE	21. SPRING	36. CONNECTOR
8. SEALING WASHER	22. O-RING	37. RETAINING CLIP (3)
9. O-RING	23. O-RING	38. SCREW (3)
10. VALVE BODY	24. PURGE VALVE HOUSING	39. RETAINER RING
11. CONNECTOR	25. PURGE VALVE	40. MOUNTING BRACKET (2)
12. NIPPLE	26. LOCKWASHER	41. NUT (2)
13. SAFETY VALVE	27. SCREW	42. LOCKWASHER (2)
14. O-RING (PART OF DEHYDRATE CARTRIDGE)	28. EXHAUST COVER	43. SCREW (2)
	29. SCREW (3)	

TA 237555

**BRAKE SYSTEM.****3-199. AIR DRYER REPAIR (Continued).**

LOCATION / ITEM	ACTION	REMARKS
A. <u>DISASSEMBLY.</u>		
1. Three screws (38) and clips (37).	Remove from item (35).	
2. Ring (39).	a. Press item (17) inward as far as it will go.  b. Pry out using flat head screwdriver.	Assistant may be needed.  Screwdriver tip can be inserted in notch of item (2) to get behind item (39).
<b>NOTE</b>		
Add location marks between end cover assembly and air dryer housing prior to disassembly. This will help you align them correctly during reassembly.		
3. Cover (17) and O-ring (16).	Remove from item (2).	Discard item (16).
4. Connector (36).	Remove from item (17).	
5. Screw (30), washer (31), and diaphragm (32).	Remove from item (28).	Discard item (32).
6. Three screws (29) and cover (28).	Remove from item (18).	
7. Valve assembly (18).	Remove from item (35) by unscrewing item (24).	

**BRAKE SYSTEM.**

**3-199. AIR DRYER REPAIR (Continued).**

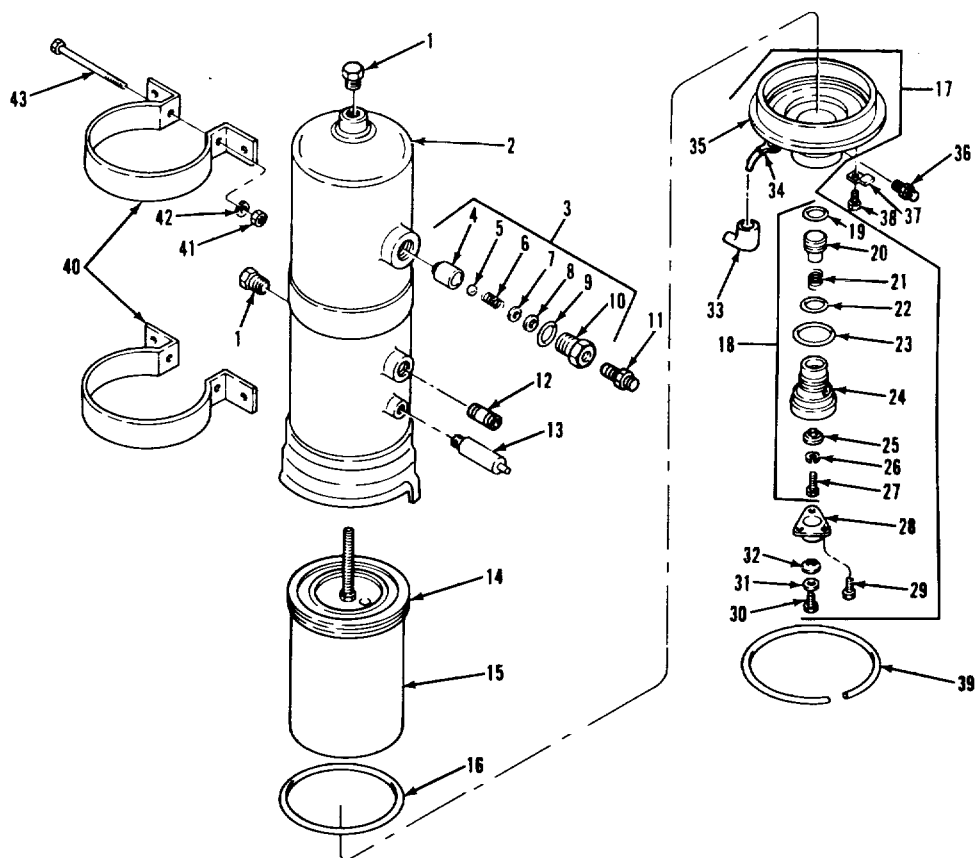

**LEGEND:**

- |  |                          |                          |
|--|--------------------------|--------------------------|
| 1. PIPE PLUG (2)                         | 15. DEHYDRATE CARTRIDGE  | 30. SCREW                |
| 2. AIR DRYER HOUSING                     | 16. O-RING               | 31. DIAPHRAGM WASHER     |
| 3. CHECK VALVE                           | 17. END COVER ASSEMBLY   | 32. EXHAUST DIAPHRAGM    |
| 4. END CAP                               | 18. PURGE VALVE ASSEMBLY | 33. BOOT                 |
| 5. BALL                                  | 19. O-RING               | 34. ELECTRICAL TERMINAL  |
| 6. SPRING                                | 20. PURGE VALVE PISTON   | 35. END COVER HOUSING    |
| 7. SPRING GUIDE                          | 21. SPRING               | 36. CONNECTOR            |
| 8. SEALING WASHER                        | 22. O-RING               | 37. RETAINING CLIP (3)   |
| 9. O-RING                                | 23. O-RING               | 38. SCREW (3)            |
| 10. VALVE BODY                           | 24. PURGE VALVE HOUSING  | 39. RETAINER RING        |
| 11. CONNECTOR                            | 25. PURGE VALVE          | 40. MOUNTING BRACKET (2) |
| 12. NIPPLE                               | 26. LOCKWASHER           | 41. NUT (2)              |
| 13. SAFETY VALVE                         | 27. SCREW                | 42. LOCKWASHER (2)       |
| 14. O-RING (PART OF DEHYDRATE CARTRIDGE) | 28. EXHAUST COVER        | 43. SCREW (2)            |
|  | 29. SCREW (3)            |                          |

TA 237556

**BRAKE SYSTEM.**

<b>3-199. AIR DRYER REPAIR (Continued),</b>		
<b>LOCATION/ITEM</b>	<b>ACTION</b>	<b>REMARKS</b>
<b><u>A. DISASSEMBLY (Continued). I</u></b>		
8. O-rings (22) and (23).	Remove from item (24)	Discard.
9. Screw (27) and piston (20)	Unscrew and remove items (21), (24), (25), and (26)	Discard items (21) and (25).
10. O-ring (19)	Remove from item (20)	Discard item (19).
11. Cartridge (15)	Unscrew and remove from item (2) using a 3/4-inch socket wrench.	Discard.
12. Valve (13)	Unscrew and remove from item (2).	
13. Connector (11)	Remove from item (3).	
14. Valve assembly (3)	Unscrew and remove from item (2).	
15. O-ring (9)	Remove from item (10)	Discard.
16. Cap (4) and body (10)	Unscrew and remove items (5), (6), (7), and (8)	Discard items (5), (6), and (8).
17. Two plugs (1)	Remove from item (2).	
18. Nipple (12)	Remove from item (2).	



**BRAKE SYSTEM.**

**3-199. AIR DRYER REPAIR (Continued).**

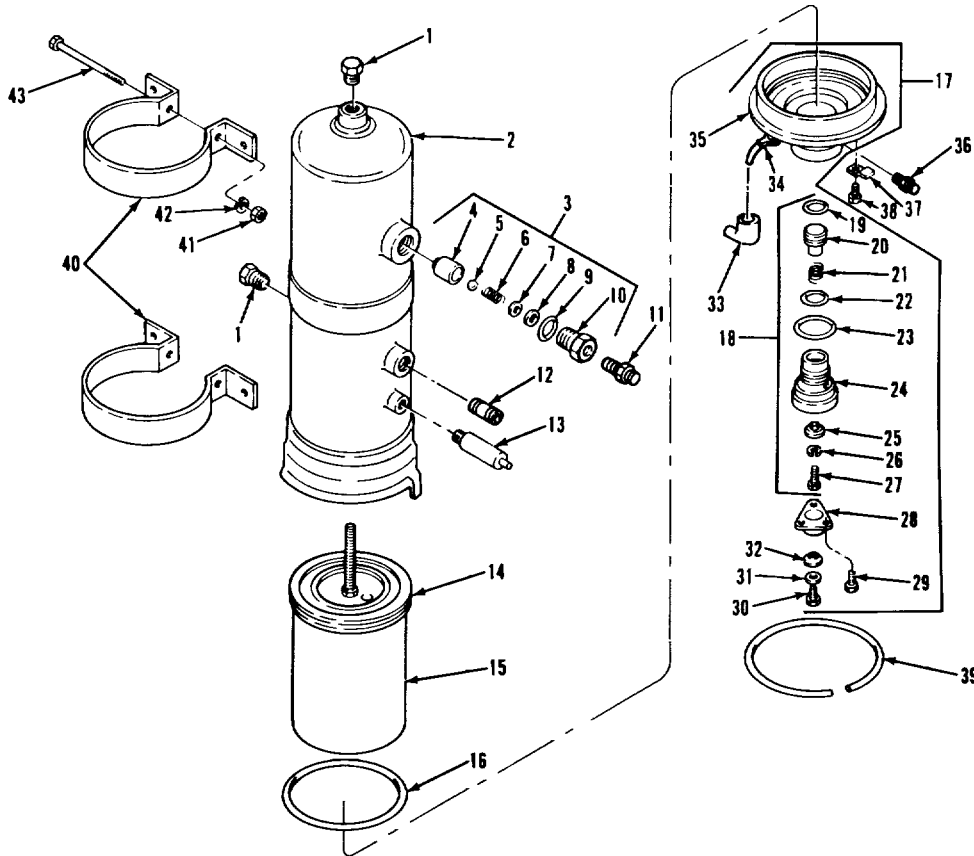

**LEGEND:**

- |   |                          |                          |
|---|--------------------------|--------------------------|
| 1. PIPE PLUG (2)                            | 15. DEHYDRATE CARTRIDGE  | 30. SCREW                |
| 2. AIR DRYER HOUSING                        | 16. O-RING               | 31. DIAPHRAGM WASHER     |
| 3. CHECK VALVE                              | 17. END COVER ASSEMBLY   | 32. EXHAUST DIAPHRAGM    |
| 4. END CAP                                  | 18. PURGE VALVE ASSEMBLY | 33. BOOT                 |
| 5. BALL                                     | 19. O-RING               | 34. ELECTRICAL TERMINAL  |
| 6. SPRING                                   | 20. PURGE VALVE PISTON   | 35. END COVER HOUSING    |
| 7. SPRING GUIDE                             | 21. SPRING               | 36. CONNECTOR            |
| 8. SEALING WASHER                           | 22. O-RING               | 37. RETAINING CLIP (3)   |
| 9. O-RING                                   | 23. O-RING               | 38. SCREW (3)            |
| 10. VALVE BODY                              | 24. PURGE VALVE HOUSING  | 39. RETAINER RING        |
| 11. CONNECTOR                               | 25. PURGE VALVE          | 40. MOUNTING BRACKET (2) |
| 12. NIPPLE                                  | 26. LOCKWASHER           | 41. NUT (2)              |
| 13. SAFETY VALVE                            | 27. SCREW                | 42. LOCKWASHER (2)       |
| 14. O-RING (PART OF<br>DEHYDRATE CARTRIDGE) | 28. EXHAUST COVER        | 43. SCREW (2)            |
|   | 29. SCREW (3)            |                          |

TA 237557

**BRAKE SYSTEM.**

3-199. AIR DRYER REPAIR (Continued).		
LOCATION/ITEM	ACTION	REMARKS
<b>A. <u>DISASSEMBLY (Continued).</u> J</b>		
<p><b>NOTE</b>                      Before removing the two mounting brackets, mark their positions on the air dryer housing. These marks will aid you during reassembly. The position of these mounting brackets is important when mounting the air dryer to the vehicle.</p>		
19. Two brackets (40), screws (43), lock-washers (42), and nuts (41).	Remove from item (2).	
<b>B. <u>CLEANING.</u> I</b>		
<p><b>NOTE</b>                      Do not immerse (soak) end cover housing in cleaning solution. The end cover housing contains a thermostat and heating element which could be damaged.</p>		
20. All parts	Clean	Refer to paragraph 3-4.
<b>C. <u>INSPECTION.</u> I</b>		
21. All parts	Inspect	Refer to paragraph 3-5.
22. Housing (35)	a. Connect to a 24V battery	Connect positive to item (34) and negative to the outer shell.
	b. Expose to temperatures below 50°F	If working properly, the heating element should begin heating the outer shell within a few minutes. If not, item
	(17) must be replaced.	
<b>3-1186</b>		

**BRAKE SYSTEM.**

**3-199. AIR DRYER REPAIR (Continued).**

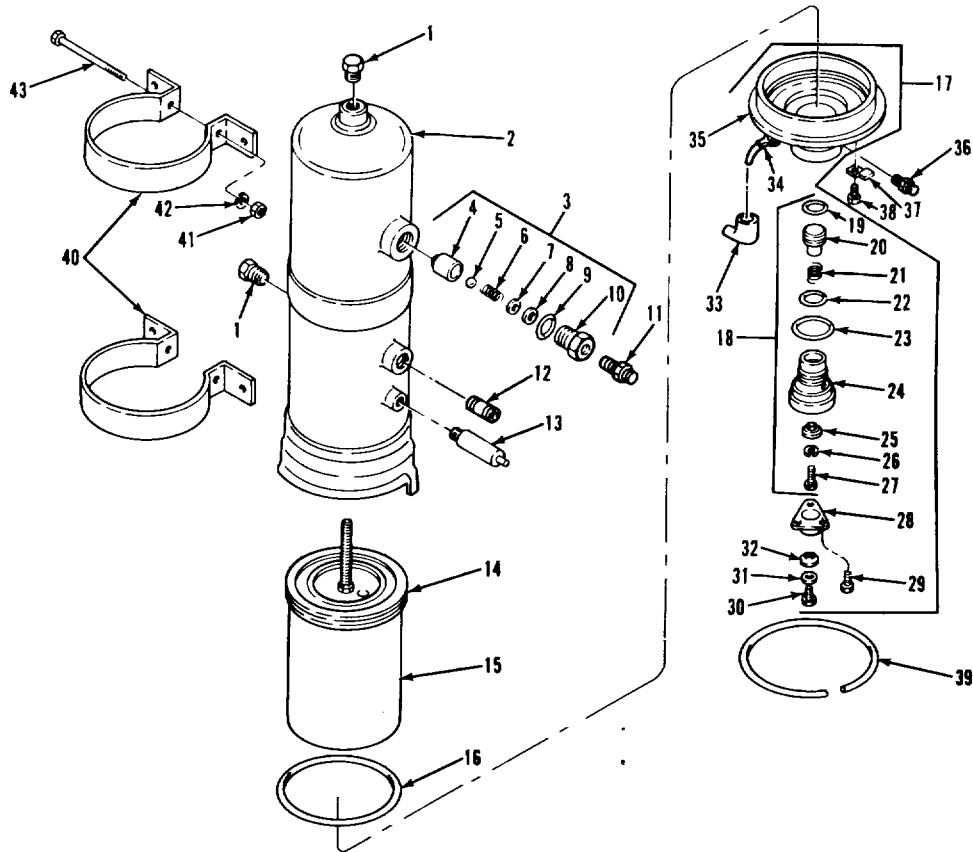

**LEGEND:**

- |   |                          |                          |
|---|--------------------------|--------------------------|
| 1. PIPE PLUG (2)                            | 15. DEHYDRATE CARTRIDGE  | 30. SCREW                |
| 2. AIR DRYER HOUSING                        | 16. O-RING               | 31. DIAPHRAGM WASHER     |
| 3. CHECK VALVE                              | 17. END COVER ASSEMBLY   | 32. EXHAUST DIAPHRAGM    |
| 4. END CAP                                  | 18. PURGE VALVE ASSEMBLY | 33. BOOT                 |
| 5. BALL                                     | 19. O-RING               | 34. ELECTRICAL TERMINAL  |
| 6. SPRING                                   | 20. PURGE VALVE PISTON   | 35. END COVER HOUSING    |
| 7. SPRING GUIDE                             | 21. SPRING               | 36. CONNECTOR            |
| 8. SEALING WASHER                           | 22. O-RING               | 37. RETAINING CLIP (3)   |
| 9. O-RING                                   | 23. O-RING               | 38. SCREW (3)            |
| 10. VALVE BODY                              | 24. PURGE VALVE HOUSING  | 39. RETAINER RING        |
| 11. CONNECTOR                               | 25. PURGE VALVE          | 40. MOUNTING BRACKET (2) |
| 12. NIPPLE                                  | 26. LOCKWASHER           | 41. NUT (2)              |
| 13. SAFETY VALVE                            | 27. SCREW                | 42. LOCKWASHER (2)       |
| 14. O-RING (PART OF<br>DEHYDRATE CARTRIDGE) | 28. EXHAUST COVER        | 43. SCREW (2)            |
|   | 29. SCREW (3)            |                          |

TA 237558

**BRAKE SYSTEM.**

3-199. AIR DRYER REPAIR (Continued).		
LOCATION/ITEM	ACTION	REMARKS
<b><u>D. REPAIR.</u></b>		
<p><b>NOTE</b>                      Repair consists of replacing defective parts discovered during inspection and replacing discarded parts with new items provided.</p>		
<b><u>E. ASSEMBLY.</u></b>		
<p><b>NOTE</b>                      When installing the two mounting brackets, align them with location markers installed prior to removal.</p>		
23. Two brackets (40), screws (43), lock-washers (42), and nuts (41).	Install on item (2).	
24. Nipple (12)	Apply thread sealer and install in item (2).	Use thread sealing tape.
25. Two plugs (1)	Apply thread sealer and install in item (2).	Use thread sealing tape.
26. Body (10)	a. Lubricate item (4)	Use silicone grease lubrication.
	b. Install new item (8).	
	c. Install item (7)	Rounded bottom goes in first.
	d. Install new item (6)	Fits in groove of item (7).
	e. Place new item (5) on new item (6).	
	f. Install item (4)	Torque to 200-225 lb-in

BRAKE SYSTEM.

3-199. AIR DRYER REPAIR (Continued).

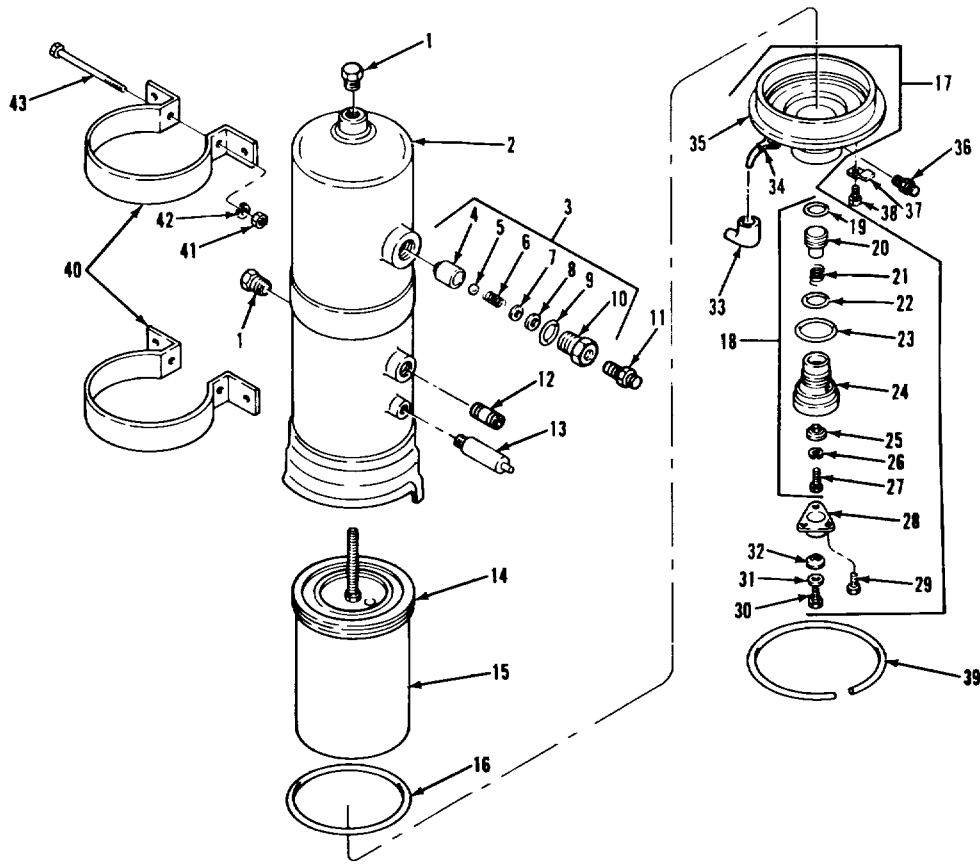

LEGEND:

- |   |                          |                          |
|---|--------------------------|--------------------------|
| 1. PIPE PLUG (2)                            | 15. DEHYDRATE CARTRIDGE  | 30. SCREW                |
| 2. AIR DRYER HOUSING                        | 16. O-RING               | 31. DIAPHRAGM WASHER     |
| 3. CHECK VALVE                              | 17. END COVER ASSEMBLY   | 32. EXHAUST DIAPHRAGM    |
| 4. END CAP                                  | 18. PURGE VALVE ASSEMBLY | 33. BOOT                 |
| 5. BALL                                     | 19. O-RING               | 34. ELECTRICAL TERMINAL  |
| 6. SPRING                                   | 20. PURGE VALVE PISTON   | 35. END COVER HOUSING    |
| 7. SPRING GUIDE                             | 21. SPRING               | 36. CONNECTOR            |
| 8. SEALING WASHER                           | 22. O-RING               | 37. RETAINING CLIP (3)   |
| 9. O-RING                                   | 23. O-RING               | 38. SCREW (3)            |
| 10. VALVE BODY                              | 24. PURGE VALVE HOUSING  | 39. RETAINER RING        |
| 11. CONNECTOR                               | 25. PURGE VALVE          | 40. MOUNTING BRACKET (2) |
| 12. NIPPLE                                  | 26. LOCKWASHER           | 41. NUT (2)              |
| 13. SAFETY VALVE                            | 27. SCREW                | 42. LOCKWASHER (2)       |
| 14. O-RING (PART OF<br>DEHYDRATE CARTRIDGE) | 28. EXHAUST COVER        | 43. SCREW (2)            |
|   | 29. SCREW (3)            |                          |

TA 237559

**BRAKE SYSTEM.****3-199. AIR DRYER REPAIR (Continued).**

LOCATION/ITEM	ACTION	REMARKS
<b><u>E. ASSEMBLY. I</u></b>		
27. New O-ring (9)	Lubricate and install on item (10)	Use silicone grease lubrication.
28. Valve assembly (3).	Install in item (2).	
29. Connector (11)	Apply thread sealer and install in item (3).	Use thread sealing tape.
30. Valve (13)	Apply thread sealer and install in item (2).	Use thread sealing tape.
31. New O-ring (14)	Lubricate lubrication.	Use silicone grease
32. Cartridge (15)	Screw into item (2) using a 3/4-inch socket wrench.	Torque to 375 lb.-in
33. Connector (36)	Apply thread sealer and install in item (35).	Use thread sealing tape.
34. New O-ring (19)	Lubricate and install on item (20)	Use silicone grease lubrication.
35. Piston (20)	Lubricate	Use silicone grease lubrication.
36. Housing (24)	a. Insert items (20) and (21).	Item (21) should be new.
	b. Insert new item (25)	Rubber end goes in first.
	c. Install items (26) and (27).	Torque to 50 lb.-in
37. O-rings (22) and (23)	Lubricate and install on item (24)	Items (22) and (23) should be new. Use silicone grease lubrication.

BRAKE SYSTEM.

3-199. AIR DRYER REPAIR (Continued).

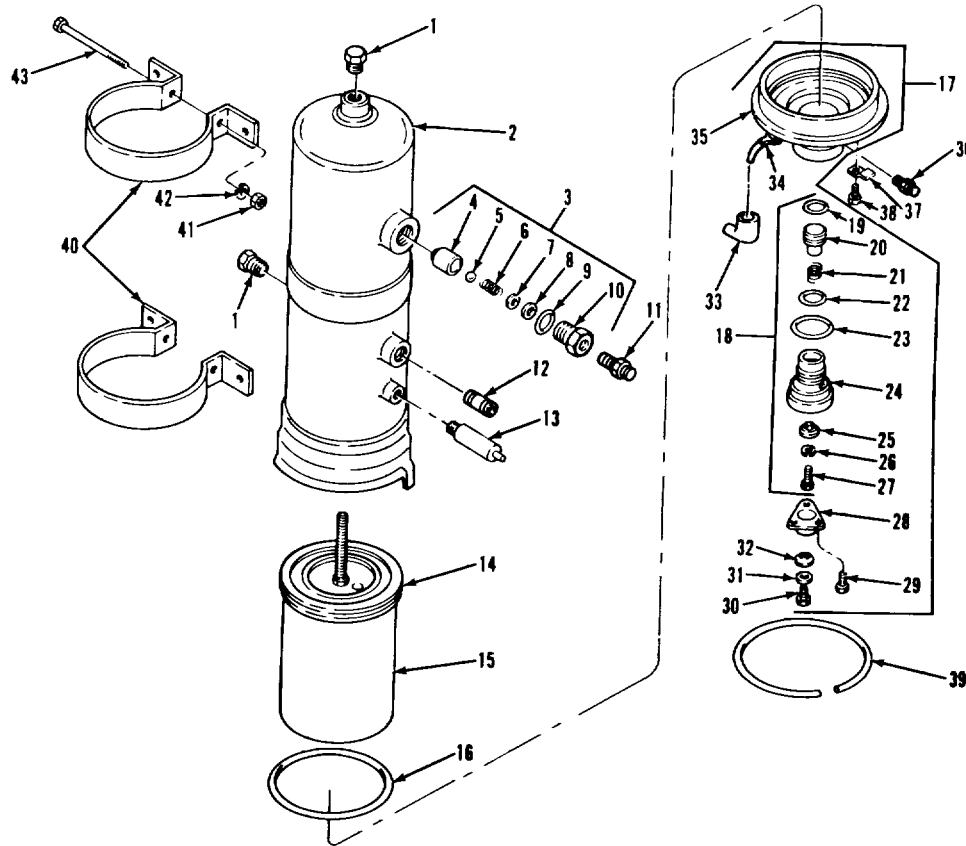

LEGEND:

- |   |                          |                          |
|---|--------------------------|--------------------------|
| 1. PIPE PLUG (2)                            | 15. DEHYDRATE CARTRIDGE  | 30. SCREW                |
| 2. AIR DRYER HOUSING                        | 16. O-RING               | 31. DIAPHRAGM WASHER     |
| 3. CHECK VALVE                              | 17. END COVER ASSEMBLY   | 32. EXHAUST DIAPHRAGM    |
| 4. END CAP                                  | 18. PURGE VALVE ASSEMBLY | 33. BOOT                 |
| 5. BALL                                     | 19. O-RING               | 34. ELECTRICAL TERMINAL  |
| 6. SPRING                                   | 20. PURGE VALVE PISTON   | 35. END COVER HOUSING    |
| 7. SPRING GUIDE                             | 21. SPRING               | 36. CONNECTOR            |
| 8. SEALING WASHER                           | 22. O-RING               | 37. RETAINING CLIP (3)   |
| 9. O-RING                                   | 23. O-RING               | 38. SCREW (3)            |
| 10. VALVE BODY                              | 24. PURGE VALVE HOUSING  | 39. RETAINER RING        |
| 11. CONNECTOR                               | 25. PURGE VALVE          | 40. MOUNTING BRACKET (2) |
| 12. NIPPLE                                  | 26. LOCKWASHER           | 41. NUT (2)              |
| 13. SAFETY VALVE                            | 27. SCREW                | 42. LOCKWASHER (2)       |
| 14. O-RING (PART OF<br>DEHYDRATE CARTRIDGE) | 28. EXHAUST COVER        | 43. SCREW (2)            |
|   | 29. SCREW (3)            |                          |

TA 237560

**BRAKE SYSTEM.**

<b>3-199. AIR DRYER REPAIR (Continued).</b>		
<b>LOCATION/ITEM</b>	<b>ACTION</b>	<b>REMARKS</b>
<b><u>E. ASSEMBLY (Continued). I</u></b>		
38. Valve assembly (18)	Lubricate and screw into item (35)	Use silicone grease lubrication.
39. Diaphragm (32), washer (31), and screw (30)	Install in item (28)	Item (28) should be new. Rounded end of item (31) should be facing item (32).
40. Cover (28) and three screws (29).	Install on item (18).	
41. New O-ring (16) groove of item (2)	Lubricate and install into	Use silicone grease lubrication.
42. Cover assembly (17)	a. Lubricate	Use silicone grease lubrication.
	b. Press into item (2) as far as it will go.	
	c. Install item (39)	Assistant may be required.
	d. Secure with three items (37) and (38).	
<p><b>NOTE</b></p> <p><b>The rubber boot installs over the heater wire which connects to the electrical terminal. The boot should be placed in a plastic bag and taped to the air dryer assembly for use during installation.</b></p> <p><b>Follow-on maintenance action required:</b></p> <p>Install air dryer (para 3-198).</p>		
<p><b>3-1192</b></p>		



BRAKE SYSTEM.

3-199. AIR DRYER REPAIR (Continued).

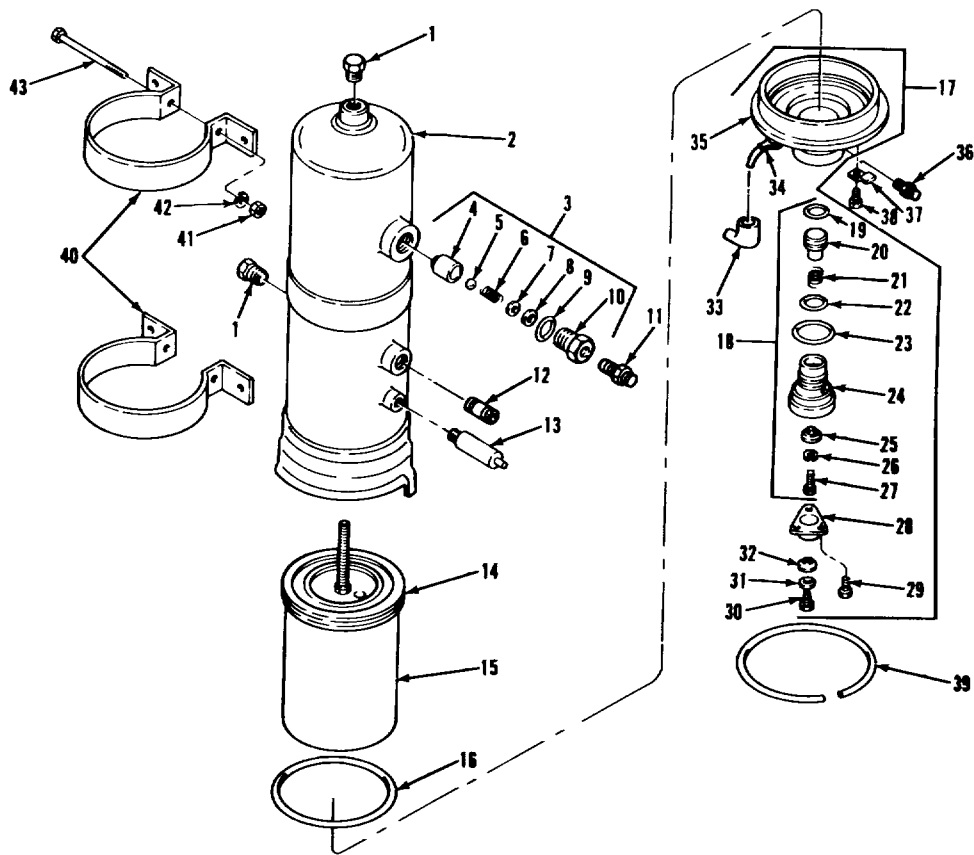

LEGEND:

- |   |                          |                          |
|---|--------------------------|--------------------------|
| 1. PIPE PLUG (2)                            | 15. DEHYDRATE CARTRIDGE  | 30. SCREW                |
| 2. AIR DRYER HOUSING                        | 16. O-RING               | 31. DIAPHRAGM WASHER     |
| 3. CHECK VALVE                              | 17. END COVER ASSEMBLY   | 32. EXHAUST DIAPHRAGM    |
| 4. END CAP                                  | 18. PURGE VALVE ASSEMBLY | 33. BOOT                 |
| 5. BALL                                     | 19. O-RING               | 34. ELECTRICAL TERMINAL  |
| 6. SPRING                                   | 20. PURGE VALVE PISTON   | 35. END COVER HOUSING    |
| 7. SPRING GUIDE                             | 21. SPRING               | 36. CONNECTOR            |
| 8. SEALING WASHER                           | 22. O-RING               | 37. RETAINING CLIP (3)   |
| 9. O-RING                                   | 23. O-RING               | 38. SCREW (3)            |
| 10. VALVE BODY                              | 24. PURGE VALVE HOUSING  | 39. RETAINER RING        |
| 11. CONNECTOR                               | 25. PURGE VALVE          | 40. MOUNTING BRACKET (2) |
| 12. NIPPLE                                  | 26. LOCKWASHER           | 41. NUT (2)              |
| 13. SAFETY VALVE                            | 27. SCREW                | 42. LOCKWASHER (2)       |
| 14. O-RING (PART OF<br>DEHYDRATE CARTRIDGE) | 28. EXHAUST COVER        | 43. SCREW (2)            |
|   | 29. SCREW (3)            |                          |

TA 237561

**BRAKE SYSTEM.**

**3-200. AIR DRYER DEHYDRATE CARTRIDGE REPLACEMENT**

THIS TASK COVERS

- a. Removal.
- b. Cleaning.
- c. Inspection.
- d. Lubrication.
- e. Installation.

INITIAL SETUP

<p><u>APPLICABLE CONFIGURATIONS</u> All opened.</p>	<p><u>EQUIPMENT CONDITION PARAGRAPH</u> TM 9-2320-283-10</p>	<p><u>CONDITION DESCRIPTION</u> Air system draincocks</p>
<p><u>TEST EQUIPMENT</u> None.</p>		
<p><u>SPECIAL TOOLS</u> None.</p>		
<p><u>MATERIALS/PARTS (P/N)</u> Grease, silicone, lubrication Item 9, Appendix B. Dehydrate cartridge assembly (06853) 286968.</p>		
<p><u>PERSONNEL REQUIRED</u> One (MOS-63S) dirt and dust.</p>	<p><u>SPECIAL ENVIRONMENTAL CONDITIONS</u> Work area clean and away from blowing dirt and dust.</p>	
<p><u>REFERENCES (TM)</u> TM 9-2320-283-10 TM 9-2320-283-20P</p>	<p><u>GENERAL SAFETY INSTRUCTIONS</u> Vehicle on level ground. Wheels blocked. Engine off. Transmission in neutral.</p>	
<p><u>TROUBLESHOOTING REFERENCES</u> Paragraph 2-11.</p>		

**BRAKE SYSTEM.**

**3-200. AIR DRYER DEHYDRATE CARTRIDGE REPLACEMENT (Continued).**

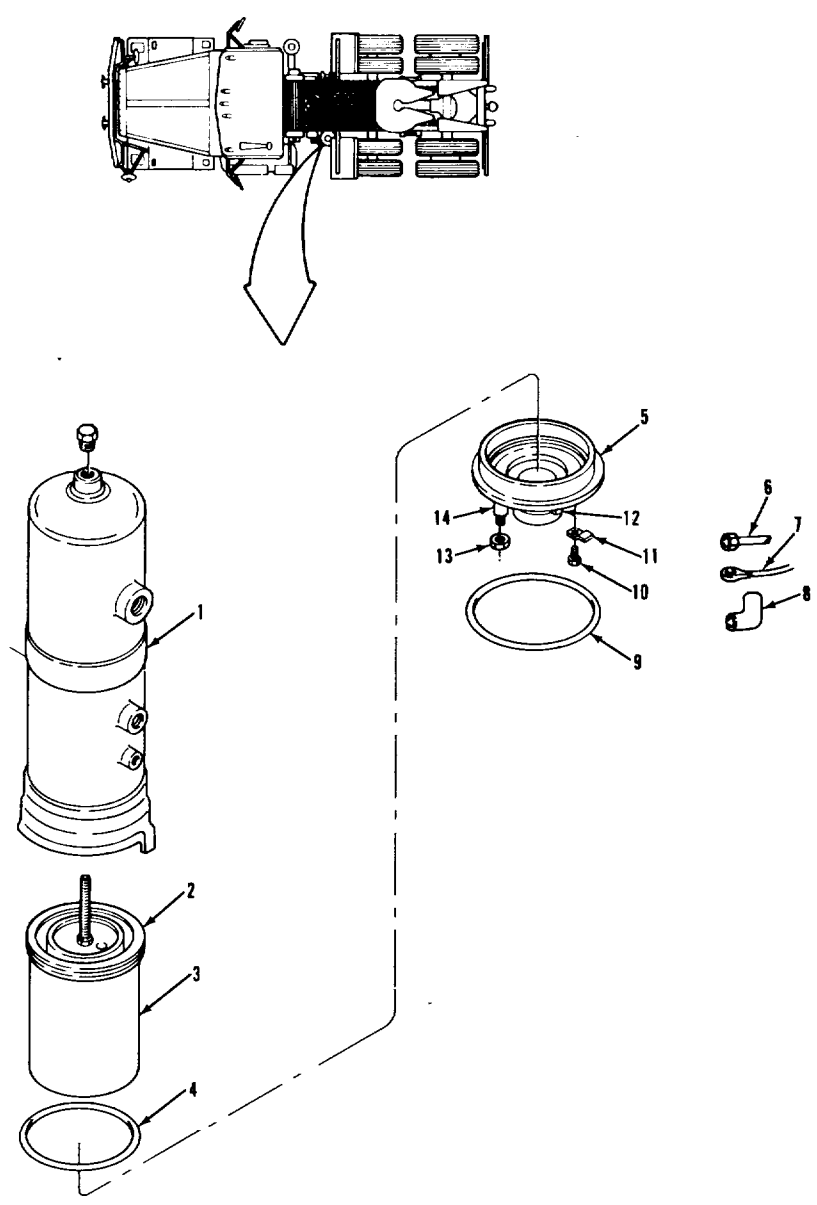

**LEGEND:**

- |   |                          |
|---|--------------------------|
| 1. AIR DRYER HOUSING                    | 8. INSULATING BOOT       |
| 2. O-RING (PART OF DEHYDRATE CARTRIDGE) | 9. RETAINING RING        |
| 3. DEHYDRATE CARTRIDGE                  | 10. SCREW AND WASHER (3) |
| 4. O-RING                               | 11. RETAINING CLIP (3)   |
| 5. END COVER ASSEMBLY                   | 12. CONNECTOR            |
| 6. HOSE ASSEMBLY                        | 13. NUT                  |
| 7. ELECTRICAL WIRE (AIR DRYER HEATER)   | 14. ELECTRICAL TERMINAL  |

TA 237562

**BRAKE SYSTEM.**

**3-200. AIR DRYER DEHYDRATE CARTRIDGE REPLACEMENT (Continued).**

LOCATION/ITEM	ACTION	REMARKS
---------------	--------	---------

**NOTE**  
**Air dryer does not have to be removed from vehicle for this operation.**

**A. REMOVAL.**

1. Wire (7), boot (8), and nut (13).	Remove from item (14).	
2. Hose (6)	Disconnect from item (12).	
3. Three clips (11)	Loosen three items (10) and turn inward	Turn so they don't touch item (1).
4. Ring (9)	While pressing up on item (5), pry out using flat head screwdriver	Insert tip of screwdriver in notch to get behind item (9).

**NOTE**  
**Make location marks between end cover assembly and the air dryer housing. This will help you align them during reassemble.**

5. Cover (5) and O-ring(4).	Remove from item (3).	
6. Cartridge (3) with O-ring (2)	Unscrew and remove from item (1) using 3/4-inch socket wrench.	Discard.

**BRAKE SYSTEM.**

**3-200. AIR DRYER DEHYDRATE CARTRIDGE REPLACEMENT (Continued).**

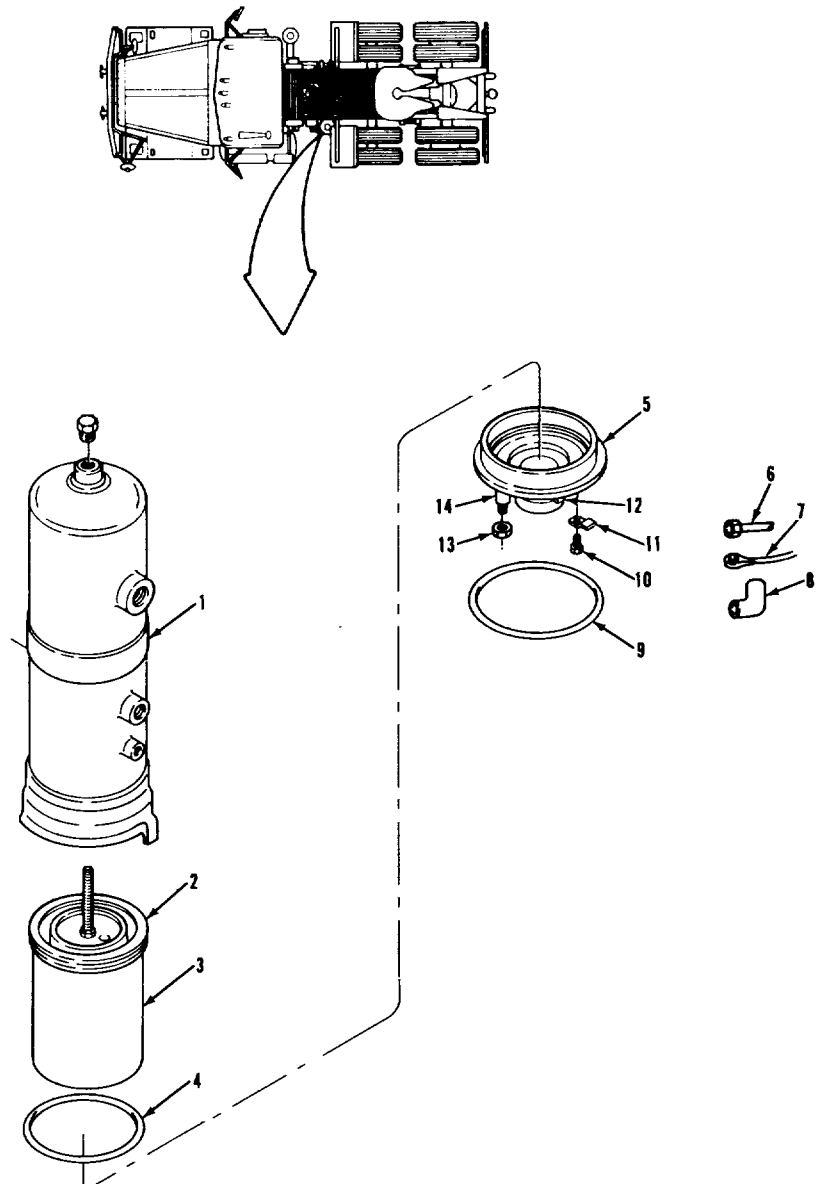

**LEGEND:**

- |   |                          |
|---|--------------------------|
| 1. AIR DRYER HOUSING                    | 8. INSULATING BOOT       |
| 2. O-RING (PART OF DEHYDRATE CARTRIDGE) | 9. RETAINING RING        |
| 3. DEHYDRATE CARTRIDGE                  | 10. SCREW AND WASHER (3) |
| 4. O-RING                               | 11. RETAINING CLIP (3)   |
| 5. END COVER ASSEMBLY                   | 12. CONNECTOR            |
| 6. HOSE ASSEMBLY                        | 13. NUT                  |
| 7. ELECTRICAL WIRE (AIR DRYER HEATER)   | 14. ELECTRICAL TERMINAL  |

TA 237564

**BRAKE SYSTEM.**

3-200. AIR DRYER DEHYDRATE CARTRIDGE REPLACEMENT (Continued).		
LOCATION/ITEM	ACTION	REMARKS
<b><u>B. CLEANING.</u></b>		
<p><b><u>CAUTION</u></b>                      Do not put end cover assembly into cleaning solvent. This could damage heating element or thermostat.</p> <p><b><u>NOTE</u></b>                      When cleaning, ensure all residue of cleaning solvent is removed before reassemble.</p>		
7. All parts	Clean	Refer to paragraph 3-4.
<b><u>C. INSPECTION.</u></b>		
8. All parts	Inspect	Refer to paragraph 3-5.
<b><u>D. LUBRICATION</u></b>		
9. O-rings (4) and (2)	Apply thin film of grease	Use silicone grease lubrication.
<b><u>E. INSTALLATION. I</u></b>		
10. New cartridge (3) with O-ring (2)	Screw into item (1) using 3/4-inch socket wrench.	Torque to 32 lb.-ft.
11. O-ring (4)	Install into item (1).	
3-1198		

BRAKE SYSTEM.

3-200. AIR DRYER DEHYDRATE CARTRIDGE REPLACEMENT (Continued).

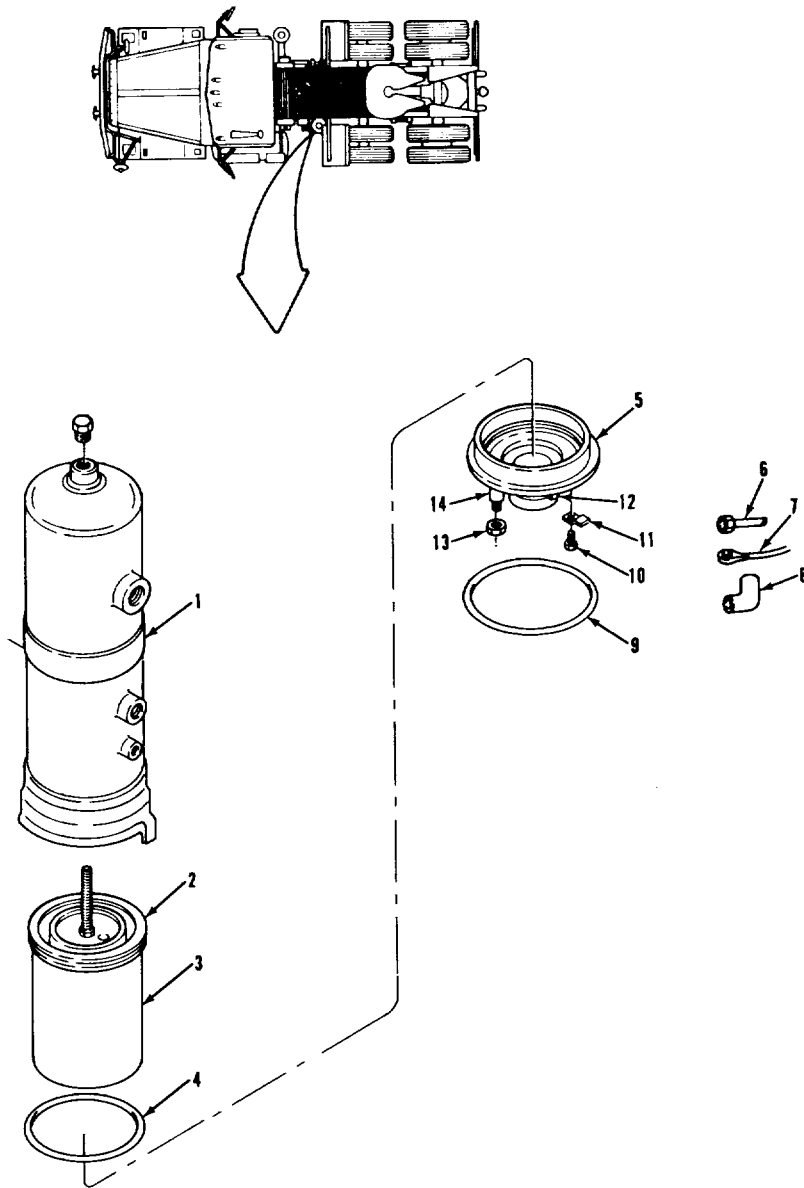

LEGEND:

- 1. AIR DRYER HOUSING
- 2. O-RING (PART OF DEHYDRATE CARTRIDGE)
- 3. DEHYDRATE CARTRIDGE
- 4. O-RING
- 5. END COVER ASSEMBLY
- 6. HOSE ASSEMBLY
- 7. ELECTRICAL WIRE (AIR DRYER HEATER)

- 8. INSULATING BOOT
- 9. RETAINING RING
- 10. SCREW AND WASHER (3)
- 11. RETAINING CLIP (3)
- 12. CONNECTOR
- 13. NUT
- 14. ELECTRICAL TERMINAL

TA 237565

**BRAKE SYSTEM.**

3-200. AIR DRYER DEHYDRATE CARTRIDGE REPLACEMENT (Continued).		
LOCATION/ITEM	ACTION	REMARKS
<b><u>E. INSTALLATION (Continued).</u></b>		
12. Cover (5)	a. Press up into item (1) as far as it will go.  b. Secure with item (9).	Align location marks.
13. Three clips (11)	a. Turn toward the outside over item (1).	
b. Secure with three items (10).		
14. Wire (7), boot (8), and nut (13).	Install on item (14).	
15. Hose (6)	Connect to item (12).	
<p><b>NOTE</b>  <b>Follow-on maintenance action required:</b>  <b>Pressurize air system, and check for leaks and proper operation (TM 9-2320-283-10).</b></p>		
<p><b>3-1200</b></p>		



BRAKE SYSTEM.

3-200. AIR DRYER DEHYDRATE CARTRIDGE REPLACEMENT (Continued).

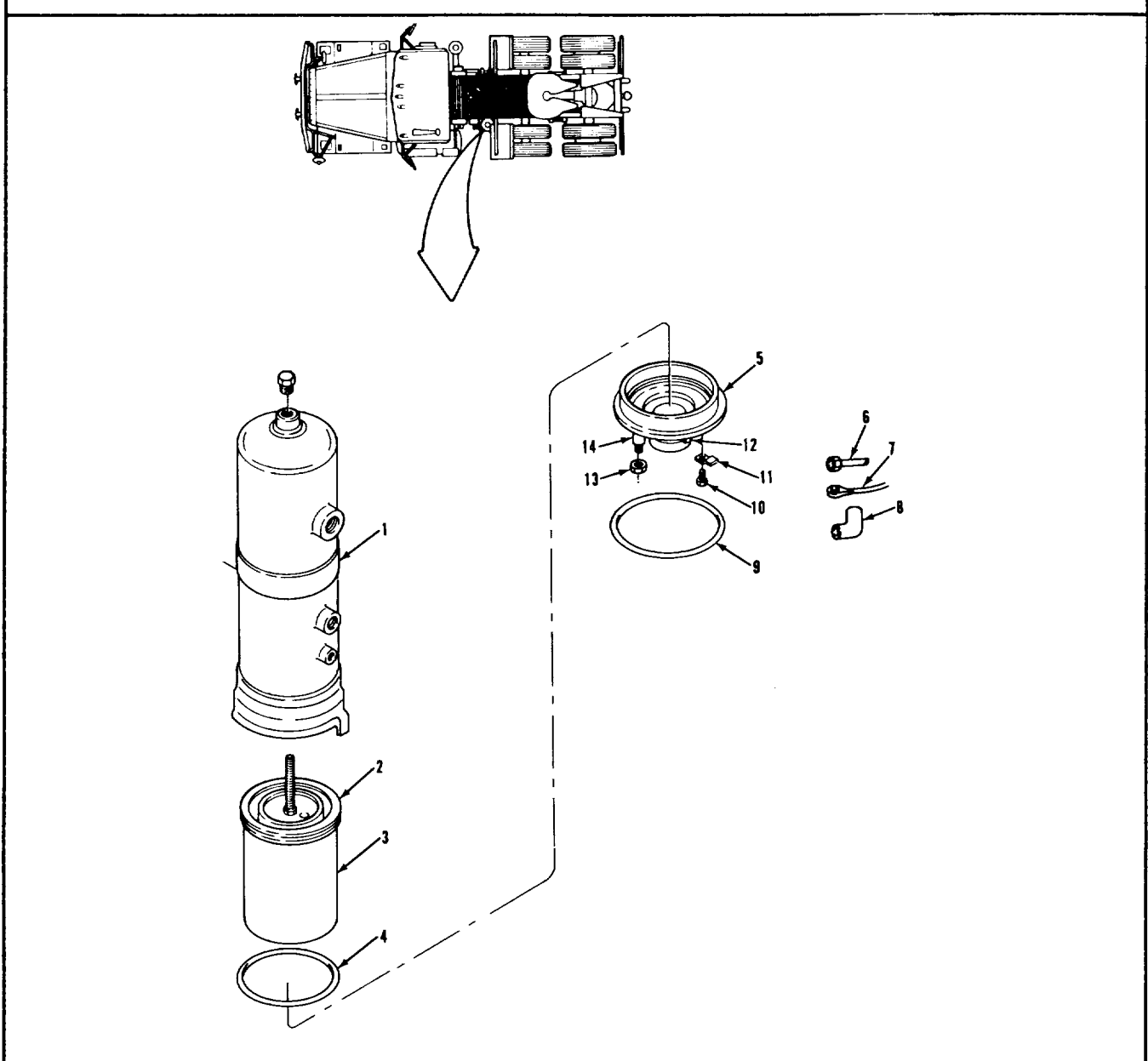

LEGEND:

- 1. AIR DRYER HOUSING
- 2. O-RING (PART OF DEHYDRATE CARTRIDGE)
- 3. DEHYDRATE CARTRIDGE
- 4. O-RING
- 5. END COVER ASSEMBLY
- 6. HOSE ASSEMBLY
- 7. ELECTRICAL WIRE (AIR DRYER HEATER)

- 8. INSULATING BOOT
- 9. RETAINING RING
- 10. SCREW AND WASHER (3)
- 11. RETAINING CLIP (3)
- 12. CONNECTOR
- 13. NUT
- 14. ELECTRICAL TERMINAL

TA 237565

**ALPHABETICAL INDEX**

Subject, Para

**A**Accelerator Pedal and Linkage  
Replacement, 3-41Accessory Items Maintenance Task  
Summary, 3-286

Adjuster Replacement, Slack, 3-157

Adjustment, Fifth Wheel, 3-244

Air Cleaner Assembly Replacement,  
3-29

Air Cleaner Filter Element Replacement, 3-30

Air Cleaner Restriction Gage and  
Bracket Replacement, 3-315Air Cleaner Restriction Gage Tube  
Replacement, 3-316

Air Cleaner Tube Replacement, 3-32

Air Crossover Connection Replacement, Turbocharger,  
3-31Air Compressor Cooling Tubes  
Replacement, 3-18Air Compressor Intake Tube Replace-  
ment, 3-19Air Diffuser Assembly Replacement,  
3-302

Subject, Para

Air Dryer Dehydrate Cartridge  
Replacement, 3-200Air Dryer Mounting Bracket  
Replacement, 3-227

Air Dryer Repair, 3-199

Air Dryer Replacement, 3-198

Air Horn and Control Valve Replacement, 3-289

Air Lines and Fittings Replacement,  
Brake System, 3-163

Alignment, Front Wheel, 3-203

Alternator and Bracket Replacement,  
3-70Alternator Drive Belts Replacement,  
3-71

Anchor Pin Replacement, 3-161

Assembly, General Maintenance  
Instructions 3-7Auxiliary Air-Powered Systems,  
Principles of Operation, 1-21**B**

Battery Box Latch Replacement, 3-123

Battery Box Replacement, 3-122

Battery Cable Replacement, 2-124

Battery Charging, 3-119

Battery Power Disconnect and Connect  
Procedure, 3-120

Battery Replacement, 3-121

Bearings Replacement, Front, 3-205

Bearings Replacement, Rear, 3-207

## ALPHABETICAL INDEX (Continued)

Subject, Para

Subject, Para

**B**Belts, Replacement, Alternator Drive  
3-71Belts Replacement, Fan Clutch Drive,  
3-67

Belt Replacement, Seat, 3-282

Belt Replacement, Water Pump Drive,  
3-63

Blackout Headlamp Assembly Replacement, 3-95

Blackout Marker Lamp and Headlamp  
Cable Replacement, 3-129Blackout Marker Lamp Assembly  
Replacement, 3-94

Blackout Taillamp Assembly Replacement, 3-97

Blackout Taillamp Mounting Bracket  
Replacement, 3-233Blackout Toggle Switch Replace-  
ment, 3-79

Blade Replacement, Wiper, 3-293

Box Replacement, Battery, 3-122

Brace Replacement, Fan, 3-24

Brace Replacement, Oil Level  
Dipstick Tube, 3-17Bracket Replacement, Air Cleaner  
Restriction, 3-315Bracket Replacement, Alternator,  
3-70Bracket Replacement, Blackout Tail lamp  
Mounting, 3-233

Bracket Replacement, Camshaft, 3-160

Bracket Replacement, Engine Lifting,  
3-22Bracket Replacement, Fire Extinguisher,  
3-284Bracket Replacement, Manual Reset  
Circuit Breaker, 3-114

Bracket Replacement, Padlock, 3-262

Bracket Replacement, Rear Mud  
Flap, 3-274Bracket Replacement, Rear Tow  
Eye, 3-235Bracket Replacement, Shifter Control  
Mounting, 3-139Bracket Replacement, STE/ICE  
Connector, 3-131

Bracket Replacement, Tail lamp, 3-234

Bracket Replacement, Trailer  
Receptacle, 3-130Bracket Replacement, Transmission  
Oil Filter Mounting, 3-231Bracket Replacement, Water Filter Tube,  
3-62Bracket Replacement, Water Transfer,  
3-21Bracket Replacement, Trailer Coupling, "-  
3-196

## ALPHABETICAL INDEX (Continued)

Subject, Para	Subject, Para
Brake Assembly Replacement, 3-158	Cab Heating and Ventilating System, Principles of Operation, 1-23
Brake Chamber Replacement, Forward-Rear Axle, 3-166	Cab Trim Panel Replacement, 3-276
Brake Chamber Replacement, Front Axle and Rear-Rear Axle, 3-164	Cable Replacement, Battery, 3-124
Brake Chamber Repair, Front Axle and Rear-Rear Axle, 3-165	Cable Replacement, Blackout Marker Lamp, 3-129
Brake Shoe Replacement, 3-159	Cable Replacement, Headlamp, 3-129
Brake System Maintenance Task Summary, 3-156	Cable Replacement, Shifter Control 3-138
Brake System, Principles of Operation, 1-20	Cable Replacement, Spare Tire Winch, 3-241
Brake Treadle Valve Replacement, 3-174	Cable Replacement, Ground, 3-128
Breather Tubes and Hoses Replacement 3-15	Camshaft and Camshaft Bracket Replacement, 3-160
Brush Guard Replacement, 3-236	Cap Replacement, Rocker Cover Filler, 3-14
Bumper, Towing Eyes, and Vehicle Class Sign Replacement, 3-237	Carrier Replacement, Spare Tire, 3-240
Button Replacement, Horn, 3-118	Cartridge Replacement, Air Dryer Dehydrate, 3-200
Buzzer Replacement, Low Air Pressure, 3-110	Center Floor Pan Access Cover Replacement, 3-260
C	Charging, Battery, 3-119
Cab and Body Maintenance Task Summary, 3-253	Checking Unpacked Equipment, Service Upon Receipt, 2-5
Cab Clearance Lamp Assembly Replacement, 3-93	Cigar Lighter Replacement, 3-83
Cab Headliner Panel Replacement, 3-275	Clamp Replacement, Oil Level Dipstick Tube, 3-17
	Cleaning, General Maintenance Instructions, 3-4

**ALPHABETICAL INDEX (Continued)**

Subject, Para	Subject, Para
Clearance Lamp Replacement, 3-85	Cooling System Service, 3-52
Clevis Pin Replacement, 3-230	Cooling Tubes Replacement, Air
Clutch Replacement, Fan, 3-65	Compressor, 3-18
Column Repair, Lower Steering, 3-215	Couplings Replacement, Front External Air, 3-167
Column Repair, Upper Steering, 3-214	Couplings Replacement, Trailer, 3-196
Column Replacement, Lower Steering, 3-215	Cover Replacement, Center Floor Pan Access, 3-260
Column Replacement, Upper Steering, 3-214	Cover Replacement, Rocker, 3-13
Common Tools and Equipment, 2-2	Cylinder Replacement, Ether, 3-38
Companion Seat Replacement, 3-283	D
Companion Seat Riser, Fire Extinguisher, Brackets, and Tool Box Replacement, 3-284	Data and Instruction Plates Replacement, 3-305
Compressed Air System, Principles of Operation, 1-19	Data Plate Replacement, Engine, 3-23
Connect Procedure, Battery Power, 3-120	Deck Replacement, Service, 3-239
Control Replacement, Modulator, 3-140	Defroster Fan Repair, 3-304
Control Replacement, Shifter, 3-137	Defroster Fan Replacement, 3-303
Cooler Replacement, Transmission and Steering System, 3-55	Deprocessing Unpacked Equipment, Service Upon Receipt, 2-6
Control Replacement, Windshield Wiper, 3-292	Destruction of Army Materiel to Prevent-Enemy Use, 1-4
Cooling System Maintenance Task Summary, 3-51	Differential Lock Pressure Switch Replacement, 3-107
Cooling System, Principles of Operation, 1-14	Differential Toggle Valve Replacement, 3-195
	Diode Replacement, Starting Circuit, 3-116

## ALPHABETICAL INDEX (Continued)

Subject, Para

Subject, Para

Dipstick Replacement, Oil Level, 3-16

Dipstick Tube Replacement, Oil Level, 3-17

Disconnect Procedure, Battery Power, 3-120

Dome Lamp and Switch Replacement, 3-98

Door Assembly Replacement, Glove Compartment, 3-257

Door Frame Seal Replacement, 3-266

Door Mirror Replacement, 3-287

Door Plate Replacement, 3-265

Double Check and Quick Release Valve Replacement, 3-182

Double Check and Stoplamp Valve Replacement, 3-183

Draincock Replacement, Primary and Secondary Reservoir, 3-188

Driver's Seat Replacement, 3-280

Driver's Seat Riser Replacement, 3-281

Drum Replacement, Front, 3-204

Drum Replacement, Rear Brake, 3-206

Dryer Repair, Air, 3-199

Dryer Replacement, Air, 3-198

Dust Shield Replacement, 3-162

## E

Electrical System Maintenance Task Summary, 3-69

Engine Data Plate Replacement, 3-23

Engine Fuel Lines and Fittings Replacement, 3-28

Engine Lifting Bracket Replacement, 3-22

Engine Maintenance Task Summary, 3-11

Engine Oil Service, 3-12

Engine, Principles of Operation, 1-11

Engine Retarder Foot Switch Replacement, 3-89

Equipment Characteristics, Capabilities, and Features, 1-8

Equipment Data, 1-10

Ether Cylinder Replacement, 3-38

Ether Lamp and Clearance Lamp Replacement, 3-85

Ether Quick Start Kit Replacement, 3-40

Ether Quick Start Thermostat Replacement, 3-39

Ether Start Switch Replacement, 3-76

Exhaust Flex Pipe Replacement, 3-47

Exhaust Stack Pipe Replacement, 3-46

**ALPHABETICAL INDEX (Continued)**

Subject, Para	Subject, Para
Exhaust System Maintenance Task Summary, 3-44	Filter Replacement, Water Separator
Exhaust System, Principles of Operation, 1-13	Fuel, 3-37
External Air Couplings Replacement, Front, 3-167	Firewall Double Check Valve Replacement, 3-184
Electrical System, Principles of Operation, 1-15	Fittings Replacement, Front Spring Pin, 3-249
<b>F</b>	Fittings Replacement, Fuel, 3-36
Fan and Fan Clutch Replacement, 3-65	Fittings Replacement, Power Steering Lines, 3-220
Fan Brace, Bracket, and Spacers Replacement, 3-24	Fittings Replacement, Transmission, 3-141
Fan Clutch Air Valve Replacement, 3-66	Fittings Replacement, Brake System, 3-163
Fan Clutch Drive Belts Replacement, 3-67	Fittings Replacement, Cooling System, 3-58
Fan Repair, Defroster, 3-304	Flasher Replacement, Turn Signal, 3-111
Fan Replacement, Defroster, 3-303	Floor Mat Replacement, 3-279
Fender Replacement, Front, 3-271	Forward-Rear Axle Brake Chamber Replacement, 3-166
Fender Replacement, Quarter, 3-272	Forward-Rear Axle Quick Release Valve Replacement, 3-178
Fifth Wheel Adjustment, 3-244	Forward-Rear Axle Stop Replacement, 3-232
Fifth Wheel Ramp Replacement, 3-246	Frame and Towing Attachments Maintenance Task Summary, 3-222
Fifth Wheel Replacement, 3-245	Front Axle and Rear-Rear Axle Brake Chamber Repair, 3-165
Fifth Wheel Toggle Valve Replacement, 3-194	Front Axle and Rear-Rear Axle Brake Chamber Replacement, 3-164
Filter Element Replacement, Air Cleaner, 3-30	
Filter Replacement, Engine Oil, 3-12	
Filter Replacement, Water, 3-62	

## ALPHABETICAL INDEX (Continued)

Subject, Para

Subject, Para

Front Axle and Suspension, Principles of Operation, 1-17

Front Axle Maintenance Task Summary, 3-147

Front Axle Ratio Valve Replacement, 3-181

Front Drum Replacement, 3-204

Front Fender Replacement, 3-271

Front Hub, Bearings, and Seals Replacement, 3-205

Front Spring Pin Screws and Fittings Replacement, 3-249

Front Wheel Alignment, 3-203

Fuel Control Lever Replacement, 3-42

Fuel Heater Replacement, 3-35

Fuel Hoses and Fittings Replacement, 3-36

Fuel Level Sending Unit Replacement, 3-105

Fuel Lines and Fittings Replacement, Engine, 3-28

Fuel Pump Engine Retarder Switch Replacement, 3-90

Fuel System Maintenance Task Summary, 3-26

Fuel System, Principles of Operation, 1-12

Fuel Tank Replacement, 3-34

## G

Gage Replacement, Air Cleaner Restriction, 3-315

Gage Replacement, Left-Hand Instrument Panel, 3-73

Gage Replacement, Oil Level, 3-136

Gage Replacement, Pressure, 3-314

Gages (Nonelectrical) Maintenance Task Summary, 3-300

Gasket Replacement, Rocker Cover, 3-13

General, Accessory Items, 3-285

General, Brake System, 3-155

General, Cab and Body, 3-252

General, Cooling System, 3-50

General, Electrical System, 3-68

General, Engine, 3-10

General, Exhaust System, 3-43

General, Frame and Towing Attachments, 3-221

General, Front Axle, 3-146

General, Fuel System, 3-25

General, Gages (Non-electrical), 3-307

General, Propeller Shafts and Universal Joints, 3-142

General, Rear Axle, 3-151



## ALPHABETICAL INDEX (Continued)

Subject, Para

General, Springs, Shock Absorbers, and Torque Rod, 3-247

General, Steering System, 3-209

General STE/ICE Components, 3-317

General, Transmission, 3-133

General Maintenance Instruction, 3-1

General, Wheels, 3-201

Glove Compartment Door Assembly Replacement, 3-257

Grille Replacement, 3-268

Ground Strap and Cables Replacement, 3-128

Guard Replacement, Brush, 3-236

**H**

Handle Replacement, Inside Assist, 3-259

Handle Replacement, Outside Front, 3-264

Handle Replacement, Outside Rear, 3-263

Headlamp Assembly Replacement, 3-91

Headlamp Assembly Replacement, Blackout, 3-95

Headlamp Cable Replacement, 3-129

Headlamp Dimmer Switch Replacement, 3-82

Headlamp Switch Replacement, 3-78

Heat Shield Replacement, Muffler, 3-45

Subject, Para

Heater Air Hose Replacement, 3-296

Heater Blower Replacement, 3-299

Heater Control Panel Repair, 3-301

Heater Control Panel Replacement, 3-300

Heater Control Valve and Hose Replacement, 3-297

Heater Fan Switch Replacement, 3-81

Heater Replacement, 3-298

Heater Replacement, Fuel, 3-35

Heater Valve, Hoses, Tubes, and Clamps Replacement, 3-297

Hood Panel and Component Replacement, 3-270

Hood Replacement, 3-269

Horn Button Replacement, 3-118

Horn Replacement, 3-117

Hose Replacement, Heater Air, 3-296

Hose Replacement, Heater Control Valve, 3-297

Hose Replacement, Trailer, 3-196

Hose Tender Replacement, 3-197

Hoses Replacement, Cooling System, 3-58

Hoses Replacement, Fuel, 3-36

Hot Engine Temperature Switch Replacement, 3-100

Housing Replacement, Thermostat, 3-59

Hub Replacement, Front, 3-207

## ALPHABETICAL INDEX (Continued)

Subject, Para

Hub Replacement, Rear, 3-207

**I**

Ignition Switch Replacement, 3-74

Indicator Lamps Replacement, 3-87

Inside Assist Handle Replacement,  
3-259

Inspection, General Maintenance

Instructions, 3-5

Instrument Panel Assembly Replacement, 3-258

Instrument Panel Center Panel  
Assembly Replacement, 3-256

Instrument Panel Relays Replacement, 3-112

Instrument Panel 24 Volt Relay  
Replacement, 3-113

Insulation Replacement, 3-277

Insulator Replacement, 3-267

Intake Tube Replacement, Air  
Compressor, 3-19Inter-axle Propeller Shaft and  
Universal Joints Replacement, 3-145**J**

Joints Replacement, Ball, 3-218

**K**Kit Replacement, Ether Quick Start,  
3-40

Subject, Para

**L**Lamp Assembly Replacement, Blackout  
Marker, 3-94Lamp Assembly Replacement, Cab  
Clearance, 3-93

Lamp Replacement, Clearance, 3-85

Lamp Replacement, Ether, 3-85

Lamp Replacement, Low Air Pressure, 3-84

Lamp Replacement, Marker Lamp, 3-92

Lamp Replacement, Turn Signal, 3-92

Lamp Replacement, Washer, 3-86

Lamp Replacement, Wiper, 3-86

Lamps Replacement, Warning and Indicator,  
3-87

Latch Replacement, Battery Box, 3-123

Left-Hand Instrument Cluster Panel  
Assembly Replacement, 3-255Left-Hand Instrument Panel Gage Replace-  
ment, 3-73

Lever Replacement, Fuel Control, 3-42

Lifting Bracket Replacement, Vehicle,  
3-229

Lighter Replacement, Cigar, 3-83

Lines and Fittings Replacement,  
Transmission, 3-141Lines, Fittings, and Hoses Replacement,  
Cooling System, 3-58

Linkage Replacement, Accelerator, 3-41

## ALPHABETICAL INDEX (Continued)

Subject, Para

Location and Description of Major Components, 1-9

Low Air Pressure Buzzer Replacement, 3-110

Low Air Pressure Lamp Replacement, 3-84

Low Air Pressure Switch Replacement, 3-109

Low Oil Pressure Sending Unit Replacement, 3-104

Lower Fan Shroud Replacement, 3-57

Lower Steering Column Replacement and Repair, 3-215

**M**

Maintenance Forms, Records, and Reports, 1-3

Manifolds Replacement, Water, 3-60

Manual Reset Circuit Breaker and

Mounting Bracket Replacement, 3-114

Map Lamp and Switch Replacement, 3-99

Marker Lamp Replacement, 3-92

Mat Replacement, Floor, 3-279

Mirror Replacement, Door, 3-287

Mirror Replacement, Spotter, 3-290

Modulator Control Replacement, 3-140

Motor Replacement, Windshield Wiper, 3-295

Subject, Para

Mountable Tee Replacement, 3-180

Muffler and Heat Shield Replacement, 3-45

Muffler Inlet Pipe Replacement, 3-49

Muffler Inlet Pipe Support Replacement, 3-224

**N**

Neutral Safety Switch and Reverse Switch Replacement, 3-106

**O**

Oil Level Dipstick Replacement, 3-16

Oil Level Dipstick Tube Brace and Clamp Replacement, 3-17

Oil Level Gage and Tube Replacement, 3-136

Oil Pressure Sending Unit Replacement, 3-102

Operational Checks, General Maintenance Instructions, 3-8

Organizational Preventive Maintenance Checks and Service (PMCS), Paragraph 2-1, 2-8

Outside Front Handle Replacement, 3-264

Outside Rear Handle Replacement, 3-263

**P**

Padlock Bracket Replacement, 3-252

## ALPHABETICAL INDEX (Continued)

Subject, Para	Subject, Para
Panel Assembly Replacement, Instrument, 2-258	Pedal Replacement, Accelerator, 3-41
Panel Assembly Replacement, Instrument Panel Center, 3-256	Pin Replacement, Clevis, 3-230
Panel Assembly Replacement, Left-Hand Instrument Cluster, 3-255	Pin Replacement, Rear Tow Eye, 3-235
Panel Assembly Replacement, Right-Hand Instrument, 3-254	Pintle Replacement, Tow, 3-238
Panel Repair, Heater Control, 3-301	Pipe Replacement, Exhaust Flex, 3-47
Panel Replacement, Cab Headliner, 3-275	Pipe Replacement, Exhaust Stack, 3-46
Panel Replacement, Cab Trim, 3-276	Pipe Replacement, Muffler Inlet, 3-49
Panel Replacement, Heater Control, 3-300	Pipe Replacement, Turbocharger Outlet, 3-48
Paragraph 2-1. Organizational Preventive Maintenance Checks and Services (PMCS), 2-8	Plate Replacement, Door, 3-265
Paragraph 2-2. Troubleshooting Procedure, 2-11	Plates Replacement, Data and Instruction, 3-305
Paragraph 2-7. GO Chain Index, STE/ICE, 2-17	Power Steering Lines and Fittings Replacement, 3-227
Paragraph 2-8. NO-GO Chain Index, STE/ICE, 2-18	Pressure Gage Replacement, 3-314
Paragraph 2-9. Vehicle Testing Troubleshooting Procedure, STE/ICE, 2-19	Pressure Transducer Replacement, 3-320
Paragraph 3-1. Torque Limits, General Maintenance Instructions, 3-9	Primary and Secondary Reservoir Draincock Replacement, 3-188
Park Brake Pressure Switch Replacement, 3-108	Primary Propeller Shaft and Universal Joints Replacement, 3-144
Park Brake Valve Repair, 3-172	Primary Reservoir Replacement, 3-169
Park Brake Valve Replacement, 3-171	Propeller Shafts and Universal Joints Maintenance Task Summary, 3-143
	Pump Replacement, Water, 3-64
	Pushbutton Clearance Lamp Switch Replacement, 3-77

## ALPHABETICAL INDEX (Continued)

Subject, Para	Subject, Para
Pushbutton Starter Switch Replacement, 3-75	Rear-Rear Axle Quick Release Valve Replacement, 3-179
Preparation for Storage or Shipment, 1-5	Rear Tandem Axles, Principles of Operation, 1-18
Primary Reservoir Drain Valve Replacement, 3-189	Rear Tow Eye Bracket, Shackle, and Pin Replacement, 3-235
Pulse Tachometer Replacement, 3-313	Receptacle Replacement, Slave Start, 3-125
Q	Receptacle Replacement, Work Lamp, 3-132
Quarter Fender Replacement, 3-272	Relay Replacement, Instrument Panel 24-Volt, 3-113
R	Relay Replacement, Starter, 3-115
Radiator Replacement, 3-53	Relay Valve Replacement, 3-177
Radiator Support Rods Replacement, 3-54	Relays Replacement, Instrument Panel, 3-112
Ramp Replacement, Fifth Wheel, 3-246	Repair, General Maintenance Instructions, 3-6
Rear Axle Maintenance Task Summary, 3-152	Repair Parts, 2-4
Rear Axle Oil Service, 3-153	Reporting Equipment Improvement Recommendations (EIR), 1-6
Rear Axle Shaft Replacement, 3-154	Reservoir Mounting Brackets Replacement, Secondary, 3-225
Rear Brake Drum Replacement, 3-206	Reservoir Replacement, Primary, 3-169
Rear Hub, Bearings, and Seals Replacement, 3-207	Reservoir Replacement, Secondary, 3-170
Rear Mud Flap and Bracket Replacement, 3-274	Reservoir Replacement, Supply, 3-168
Rear-Rear Axle Brake Chamber Repair, 3-165	Reservoir Replacement, Steering Pump, 3-219
Rear-Rear Axle Brake Chamber Replacement, 3-164	

## ALPHABETICAL INDEX (Continued)

Subject, Para	Subject, Para
Right-Hand Instrument Cluster Panel Assembly Replacement, 3-254	Secondary Reservoir Support Replacement, 3-223
Rocker Cover and Gasket Replacement, 3-13	Sending Unit Replacement, Fuel Level, 3-105
Rocker Cover Filler Cap Replacement, 3-14	Sending Unit Replacement, Oil Pressure, 3-102
Rods Replacement, Radiator Support, 3-54	Sending Unit Replacement, Transmission Temperature, 3-103
Rods Replacement, Torque, 3-251	Sending Unit Replacement, Water Temperature, 3-101
S	Service and Troubleshooting Instructions, 2-1
Scope, 1-2	Service Deck Replacement, 3-239
Screws Replacement, Front Spring Pin, 3-249	Service, Cooling System, 3-52
Seal Replacement, Door Frame, 3-266	Service, Engine Oil, 3-12
Seals Replacement, Front 3-205	Service, Rear Axle Oil, 3-153
Seals Replacement, Rear, 3-207	Service, Steering System, 3-211
Seat Belt Replacement, 3-282	Servicing, Transmission, 3-135
Seat Replacement, Companion, 3-283	Shackle Replacement, Rear Tow Eye, 3-235
Seat Replacement, Driver's, 3-280	Shaft Replacement, Rear Axle, 3-154
Seat Riser Replacement, Driver's, 3-281	Shaft Replacement, Speedometer, 3-310
Secondary Reservoir Check Valve Replacement, 3-187	Shaft Replacement, Tachometer, 3-312
Secondary Reservoir Double Check Valve Replacement, 3-185	Shield Replacement, Dust, 3-162
Secondary Reservoir Replacement, 3-170	Shifter Control Cable Replacement, 3-138
	Shifter Control Mounting Bracket Replacement, 3-139

## ALPHABETICAL INDEX (Continued)

Subject, Para	Subject, Para
Shifter Control Replacement, 3-137	Splash Shield Replacement, 3-273
Shock Absorber Replacement, 3-250	Spotter Mirror Replacement, 3-288
Shroud Replacement, Lower Fan, 3-57	Springs, Shock Absorbers, and Torque Rods Maintenance Task Summary, 3-248
Shroud Replacement, Upper Fan, 3-56	Starter Motor and Solenoid Replacement, 3-72
Sign Replacement, Vehicle Class, 3-23;	Starter Relay Replacement, 3-115
Slack Adjuster Replacement, 3-157	Starting Circuit Diode Replacement, 3-116
Slave Start Receptacle Replacement, 3-125	STE/ICE, How To Use Chain Test Index, 2-13
Solenoid Replacement, Starter Motor, 3-72	STE/ICE Components Maintenance Task Summary, 3-318
Solenoid Valve Replacement, 3-33	STE/ICE Connector Bracket Replacement, 3-131
Spacers Replacement, 3-24	STE/ICE Description and Operation, 2-16
Spare Tire Carrier Replacement, 3-240	STE/ICE, Paragraph 2-7. GO Chain Index, 2-17
Spare Tire Winch Cable Replacement, 3-241	STE/ICE, GO Chain Tests, 2-20
Spare Tire Winch Pillar Replacement, 3-243	STE/ICE, Paragraph 2-8. NO-GO Chain Index, 2-18
Spare Tire Winch Replacement, 3-242	STE/ICE, NO-GO Chain Tests, 2-21
Special Tools, TMDE, and Support Equipment, 2-3	STE/ICE, Paragraph 2-9. Vehicle Testing Troubleshooting Procedure, 2-19
Speedometer Drive Sleeve Adapter Replacement, 3-311	STE/ICE VTM Set-Up Procedure, 3-15
Speedometer Driven Gear Replacement, 3-312	STE/ICE Vehicle Test Meter (VTM) Troubleshooting, 2-14
Speedometer Shaft Replacement, 3-310	Steering Arm Replacement, Front Axle, 3-148
Spider and Anchor Pin Replacement, 3-161	

## ALPHABETICAL INDEX (Continued)

Subject, Para	Subject, Para
Steering Arm Replacement, Steering System, 3-217	Support Replacement, Secondary Reservoir, 3-223
Steering Knuckle Assembly Replacement 3-149	Switch Replacement, Blackout Toggle, 3-79
Steering Pump and Reservoir Replacement, 3-219	Switch Replacement, Differential Lock Pressure, 3-107
Steering System Maintenance Task Summary, 3-210	Switch Replacement, Engine Retarder Foot, 3-89
Steering System, Principles of Operation, 1-22	Switch Replacement, Ether Start, 3-76
Steering System Service, 3-211	Switch Replacement, Fuel Pump Engine Retarder, 3-90
Steering System Testing, 3-212	Switch Replacement, Headlamp, 3-78
Steering Wheel Replacement, 3-213	Switch Replacement, Headlamp Dimmer, 3-82
Step Replacement, 3-226	Switch Replacement, Heater Fan, 3-81
Stop Replacement, Forward-Rear Axle, 3-232	Support Replacement, Secondary Reservoir, 3-223
Stoplamp-Taillamp Assembly Replacement, 3-96	Switch Replacement, Hot Engine Temperature, 3-100
Strap Replacement, Ground, 3-128	Switch Replacement, Ignition, 3-74
Sun Visor Replacement, 3-278	Switch Replacement, Low Air Pressure, 3-109
Supply Reservoir Drain Valve Replacement, 3-190	Switch Replacement, Neutral Safety, 3-106
Supply Reservoir Mounting Brackets Replacement, 3-225	Switch Replacement, Park Brake Pressure, 3-108
Supply Reservoir Replacement, 3-168	Switch Replacement, Pushbutton Clearance Lamp, 3-77
Supply Reservoir Safety Valve Replacement, 3-186	Switch Replacement, Pushbutton Starter, 3-75
Supply Reservoir Single Check Valve Replacement, 3-191	Switch Replacement, Reverse, 3-106
Support Replacement, Muffler Inlet Pipe, 3-224	



## ALPHABETICAL INDEX (Continued)

Subject, Para	Subject, Para
Switch Replacement, Three Position Engine Retarder, 3-88	Task Summary, Fuel System Maintenance, 3-26
Switch Replacement, Turn Signal, 3-80	Task Summary, Gages (Nonelectrical) Maintenance, 3-308
Symptom Index, Troubleshooting, 2-10	Task Summary, Rear Axle Maintenance, 3-152
T	Task Summary, Springs, Shock Absorbers, and Torque Rods Maintenance, 3-248
Tachograph Replacement, 3-309	Task Summary, Steering System Maintenance, 3-210
Tachometer Replacement, Pulse, 3-319	Task Summary, STE/ICE Components Maintenance, 3-318
Tachometer Shaft Replacement, 3-313	Task Summary, Transmission Maintenance, 3-134
Tail-lamp Bracket Replacement, 3-234	Task Summary, Wheel Maintenance, 3-202
Tank Replacement, Fuel, 3-34	Tee Replacement, Mountable, 3-180
Task Summary, Accessory Items Maintenance, 3-286	Testing, Steering System, 3-212
Task Summary, Brake System Maintenance, 3-156	Three Position Engine Retarder Switch Replacement, 3-88
Task Summary, Cab and Body Maintenance, 3-253	Tiedown Bracket Replacement, 3-228
Task Summary, Cooling System Maintenance, 3-51	Tie Rod Arm Replacement, 3-150
Task Summary, Electrical System Maintenance, 3-69	Tire Replacement, 3-208
Task Summary, Engine Maintenance, 3-11	Thermostat and Thermostat Housing Replacement, 3-59
Task Summary, Exhaust System Maintenance, 3-44	Thermostat Replacement, Ether Quick Start, 3-39
Task Summary, Frame and Towing Attachments, 3-229	Tie Rod and Ball Joints Replacement, 3-218
Task Summary, Front Axle Maintenance, 3-147	Tool Box Replacement, 3-284

## ALPHABETICAL INDEX (Continued)

Subject, Para	Subject, Para
Torque Limits, Paragraph 3-1. General Maintenance Instructions, 3-9	Troubleshooting Procedures, Paragraph 2-2, 2-11
Torque Rods Replacement, 3-251	Troubleshooting Symptom Index, 2-10
Tow Pintle Replacement, 3-238	Tube Replacement, Air Cleaner, 3-32
Towing Eyes Replacement, Front, 2-237	Tube Replacement, Oil Level, 3-136
Tractor Protection Valve Replacement, 3-192	Tube Replacement, Water Crossover, 3-20
Trailer Couplings, Brackets, and Hose Replacement, 3-196	Tube Replacement, Water Transfer, 3-21
Trailer Hand Brake Valve Replacement, 3-173	Turbocharger Air Crossover Connection Replacement, 3-31
Trailer Receptacle Bracket Replace- ment, 3-130	Turbocharger Outlet Pipe Replacement, 3-48
Trailer Supply Valve Repair, 3-176	Turn Signal and Marker Lamp Replacement, 3-92
Trailer Supply Valve Replacement, 3-175	Turn Signal Flasher Replacement, 3-111
Transducer Replacement, Pressure, 3-320	Turn Signal Switch Replacement, 3-80
Transmission and Steering System Cooler Replacement, 3-55	U
Transmission Maintenance Task Summary, 3-134	Universal Joints Replacement, Interaxle Propeller Shaft, 3-145
Transmission Oil Filter Mounting Bracket Replacement, 3-231	Universal Joints Replacement, Primary Propeller Shaft, 3-144
Transmission, Principles of Operation, 1-16	Upper Fan Shroud Replacement, 3-56
Transmission Servicing, 3-135	Upper Steering Column Replacement and Repair, 3-214
Transmission Temperature Sending Unit Replacement, 3-103	V
	Valve Relay, Replacement, 3-177
	Valve Repair, Park Brake, 3-172

## ALPHABETICAL INDEX (Continued)

Subject, Para	Subject, Para
Valve Repair, Trailer Supply, 3-176	Valve Replacement, Rear-Rear Axle Quick Release, 3-179
Valve Replacement, Air Horn Control, 3-289	Valve Replacement, Secondary Reservoir Check, 3-187
Valve Replacement, Brake Pedal Double Check, 3-193	Valve Replacement, Secondary Reservoir Double Check, 3-185
Valve Replacement, Brake Treadle, 3-174	Valve Replacement, Solenoid, 3-33
Valve Replacement, Differential Toggle, 3-195	Valve Replacement, Supply Reservoir Drain, 3-190
Valve Replacement, Double Check and Quick Release, 3-182	Valve Replacement, Supply Reservoir Safety, 3-186
Valve Replacement, Double Check and Stoplamp, 3-183	Valve Replacement, Supply Reservoir Single Check, 3-191
Valve Replacement, Fan Clutch Air, 3-66	Valve Replacement, Tractor Protection, 3-192
Valve Replacement, Fifth Wheel Toggle, 3-194	Valve Replacement, Trailer Hand Brake, 3-175
Valve Replacement, Firewall Double Check, 3-184	Valve Replacement, Trailer Supply, 3-177
Valve Replacement, Forward-Rear Axle Quick Release, 3-178	Valve Replacement, Water Shutoff, 3-61
Valve Replacement, Front Axle Ratio, 3-181	Valve Replacement, Windshield Water Control, 3-291
Valve Replacement, Heater Control, 3-297	Vehicle Lifting Bracket Replacement, 3-229
Valve Replacement, Park Brake, 3-171	Vehicle Test Meter (VTM) Troubleshooting, STE/ICE, 2-14
Valve Replacement, Primary Reservoir Drain, 3-189	Ventilator Replacement, 3-261
	Vertical Link Replacement, 3-216
	Visor Replacement, Sun, 3-278

## ALPHABETICAL INDEX (Continued)

Subject, Para	Subject, Para
W	
Warning and Indicator Lamps Replacement, 3-87	Windshield Washer Control Valve Replacement, 3-291
Warranty Information, 1-7	Windshield Washer Replacement, 3-290
Water Crossover Tube Replacement, 3-20	Windshield Wiper Assembly Replacement, 3-294
Washer Lamp Replacement, 3-86	Windshield Wiper Control Replacement, 3-292
Washer Replacement, Windshield, 3-290	Windshield Wiper Motor Replacement, 3-295
Water Filter and Bracket Replacement, 3-62	Winterization Kit, Principles of Operation, 1-24
Water Manifolds Replacement, 3-60	Winterization Kit (See TB 9-2320-283-14), 3-300
Water Pump Drive Belt Replacement, 3-63	Wiper Blade Replacement, 3-293
Water Pump Replacement, 3-64	Wiper Lamp and Washer Lamp Replacement, 3-86
Water Separator Fuel Filter Replacement, 3-37	Wiring Harness Repair, 3-127
Water Shutoff Valves and Lines Replacement, 3-61	Wiring Harness Replacement, 3-126
Water Temperature Sending Unit Replacement, 3-101	Work Lamp Receptacle Replacement, 3-132
Water Transfer Tube and Bracket Replacement, 3-21	
Wheels Maintenance Task Summary, 3-202	
Wheel Replacement, Steering, 3-213	
Winch Repair, Spare Tire, 3-242	
Winch Replacement, Spare Tire, 3-237	

By Order of the Secretary of the Army:

E.C. MEYERS  
General, United States Army  
Chief of Staff

Official:

JOHN A. WICKHAM, JR.  
Brigadier General, United States Army  
The Adjutant General

Distribution:

To be distributed in accordance with DA Form 12-38, (qty rqr block No. 330), organizational maintenance requirements for Truck, Tractor, Line Haul, 6 x 4, 14-ton, M915A1.

☆U.S. GOVERNMENT PRINTING OFFICE: 1993- 342-421/62541

## THE METRIC SYSTEM AND EQUIVALENTS

### LINEAR MEASURE

- 1 Centimeter = 10 Millimeters = 0.01 Meters = 0.3937 Inches
- 1 Meter = 100 Centimeters = 1,000 Millimeters = 39.37 Inches
- 1 Kilometer = 1,000 Meters = 0.621 Miles

### SQUARE MEASURE

- 1 Sq Centimeter = 100 Sq Millimeters = 0.155 Sq Inches
- 1 Sq Meter = 10,000 Sq Centimeters = 10.76 Sq Feet
- 1 Sq Kilometer = 1,000,000 Sq Meters = 0.386 Sq Miles

### CUBIC MEASURE

- 1 Cu Centimeter = 1,000 Cu Millimeters = 0.06 Cu Inches
- 1 Cu Meter = 1,000,000 Cu Centimeters = 35.31 Cu Feet

### LIQUID MEASURE

- 1 Milliliter = 0.001 Liters = 0.0338 Fluid Ounces
- 1 Liter = 1,000 Milliliters = 33.82 Fluid Ounces

### TEMPERATURE

- $5/9 (^{\circ}\text{F} - 32) = ^{\circ}\text{C}$
- 212° Fahrenheit is equivalent to 100° Celsius
- 90° Fahrenheit is equivalent to 32.2° Celsius
- 32° Fahrenheit is equivalent to 0° Celsius
- $9/5 \text{ } ^{\circ}\text{C} + 32 = \text{ } ^{\circ}\text{F}$

### WEIGHTS

- 1 Gram = 0.001 Kilograms = 1,000 Milligrams = 0.035 Ounces
- 1 Kilogram = 1,000 Grams = 2.2 lb.
- 1 Metric Ton = 1,000 Kilograms = 1 Megagram = 1.1 Short Tons

### APPROXIMATE CONVERSION FACTORS

TO CHANGE	TO	MULTIPLY BY
Inches	Centimeters	2.540
Feet	Meters	0.305
Yards	Meters	0.914
Miles	Kilometers	1.609
Square Inches	Square Centimeters	6.451
Square Feet	Square Meters	0.093
Square Yards	Square Meters	0.836
Square Miles	Square Kilometers	2.590
Acres	Square Hectometers	0.405
Cubic Feet	Cubic Meters	0.028
Cubic Yards	Cubic Meters	0.765
Fluid Ounces	Milliliters	29.573
Pints	Liters	0.473
Quarts	Liters	0.946
Gallons	Liters	3.785
Ounces	Grams	28.349
Pounds	Kilograms	0.454
Short Tons	Metric Tons	0.907
Pound-Feet	Newton-Meters	1.356
Pounds Per Square Inch	Kilopascals	6.895
Miles Per Gallon	Kilometers Per Liter	0.425
Miles Per Hour	Kilometers Per Hour	1.609
TO CHANGE	TO	MULTIPLY BY
Centimeters	Inches	0.394
Meters	Feet	3.280
Meters	Yards	1.094
Kilometers	Miles	0.621
Square Centimeters	Square Inches	0.155
Square Meters	Square Feet	10.764
Square Meters	Square Yards	1.196
Square Kilometers	Square Miles	0.386
Square Hectometers	Acres	2.471
Cubic Meters	Cubic Feet	35.315
Cubic Meters	Cubic Yards	1.308
Milliliters	Fluid Ounces	0.034
Liters	Pints	2.113
Liters	Quarts	1.057
Liters	Gallons	0.264
Grams	Ounces	0.035
Kilograms	Pounds	2.205
Metric Tons	Short Tons	1.102
Newton-Meters	Pound-Feet	0.738
Kilopascals	Pounds Per Square Inch	0.145
Kilometers Per Liter	Miles Per Gallon	2.354
Kilometers Per Hour	Miles Per Hour	0.621

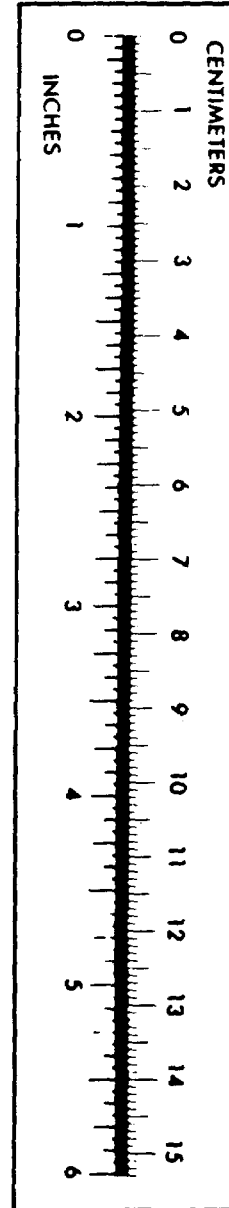

RECOMMENDED CHANGES TO EQUIPMENT TECHNICAL PUBLICATIONS



THEN... JOT DOWN THE DOPE ABOUT IT ON THIS FORM, CAREFULLY TEAR IT OUT, FOLD IT AND DROP IT IN THE MAIL!

**SOMETHING WRONG WITH THIS PUBLICATION?**

FROM: (PRINT YOUR UNIT'S COMPLETE ADDRESS)

DATE SENT

PUBLICATION NUMBER

PUBLICATION DATE

PUBLICATION TITLE

BE EXACT... PIN-POINT WHERE IT IS

IN THIS SPACE TELL WHAT IS WRONG AND WHAT SHOULD BE DONE ABOUT IT:

PAGE NO.	PARA-GRAPH	FIGURE NO.	TABLE NO.
----------	------------	------------	-----------

TEAR ALONG PERFORATED LINE

PRINTED NAME, GRADE OR TITLE, AND TELEPHONE NUMBER

SIGN HERE:

DA FORM 2028-2 JUL 79

PREVIOUS EDITIONS ARE OBSOLETE.

P.S.—IF YOUR OUTFIT WANTS TO KNOW ABOUT YOUR RECOMMENDATION MAKE A CARBON COPY OF THIS AND GIVE IT TO YOUR HEADQUARTERS.

