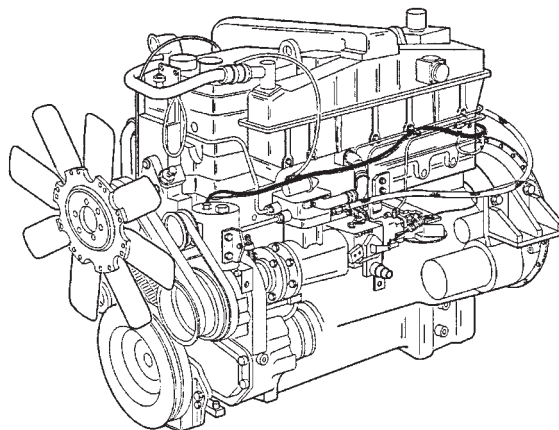

**DIRECT SUPPORT AND GENERAL SUPPORT
MAINTENANCE MANUAL INCLUDING
REPAIR PARTS AND SPECIAL
TOOLS LIST (RPSTL)**

FOR

**ENGINE, DIESEL: 6 CYLINDER IN-LINE
TURBOCHARGED, CUMMINS MODEL NTC-400**

**BIG CAM I
(NSN 2815-01-082-8125)**

**BIG CAM III
(NSN 2815-01-142-2745)**



BIG CAM III SHOWN.

ALL TRUCKS M915-M920 AND M915A4 CAN BE EQUIPPED WITH EITHER BIG CAM I OR BIG CAM III ENGINES.

DISTRIBUTION STATEMENT A: Approved for public release; distribution is unlimited.

HEADQUARTERS, DEPARTMENT OF THE ARMY

JULY 2005

WARNING SUMMARY

Operating a deadlined vehicle without preliminary inspection will cause further damage to a malfunctioning component and possible injury to personnel.

Use extreme care when handling heavy parts. Provide adequate support and use assistance during procedure. Ensure that any lifting device used is in good operating condition and of suitable load capacity. Keep clear of heavy components supported only by lifting device. Failure to comply may result in death or injury to personnel.

Compressed air used for cleaning purposes must not exceed 30 psi. Use only with effective chip guarding and personal protective equipment (goggles/shield, gloves, etc.). Failure to comply may result in death or injury to personnel.

When removing hood tilt assist cables, hood must be supported. Failure to comply may result in damage to equipment or injury to personnel.

Use pry bars to free engine hangups or snags. Do not use hands. Failure to comply may result in damage to equipment or death or injury to personnel.

Use extreme care during engine accessory removal. Engine parts are heavy. Failure to comply may result in death or injury to personnel.

Eye protection must be worn when using wire brush for cleaning. Failure to comply may result in injury to personnel.

Wear rubber gloves when removing piston pin to prevent burns from hot water or hot piston. Failure to comply may result in injury to personnel.

Oil pump pressure regulator spring is under tension. Remove oil pump pressure regulator slowly and wear proper eye protection. Failure to comply may result in injury to personnel.

Oil pump pressure regulator spring is under tension. Install oil pump pressure regulator screw slowly and wear proper eye protection. Failure to comply may result in injury to personnel.

Oil pump pressure regulator spring is under tension. Remove oil pump bypass screw slowly and wear proper eye protection. Failure to comply may result in injury to personnel.

Turbine wheel machined edges are very sharp. Wear protective gloves when handling turbine wheel. Failure to comply may result in injury to personnel.

Control valve cover is under control valve outer spring pressure. Hold cover securely when removing screws. Failure to comply may cause injury to personnel.

Slave piston spring is highly compressed. Be extremely careful during disassembly. Personal injury can occur if spring force is not controlled.

Use gloves during piston pin installation if piston has been soaked in hot water. Failure to comply may result in injury to personnel.

Do not perform fuel system procedures while smoking or within 50 ft (15.2 m) of sparks or open flame. Diesel fuel is flammable and may explode. Failure to comply may result in injury or death to personnel.

WARNING SUMMARY (Contd)

Allow adequate ventilation for engine exhaust gases. Do not perform fuel system procedures while smoking or within 50 ft (15.2 m) of sparks or open flame. Diesel fuel is flammable and may explode. Failure to comply may result in serious injury or death to personnel.

Use extreme caution during disassembly or assembly; engine components are heavy. Failure to comply may result in damage to equipment or injury to personnel.

All personnel must stand clear during lifting operations. A snapped chain or swinging or shifting load may result in injury to personnel.

When installing hood tilt assist cables, hood must be supported. Failure to comply may result in damage to equipment or injury to personnel.

Compressed air source must not exceed 30 psi (207 kPa). Wear eyeshields when cleaning with compressed air. Failure to comply may result in injury to personnel.

LIST OF EFFECTIVE PAGES/WORK PACKAGES

The date of issue for original pages/work pages for this TM is:

Original 21 July 2005

TOTAL NUMBER OF PAGES IN THIS PUBLICATION IS 651.

TOTAL NUMBER OF WORK PACKAGES IS 62.

THE PAGES/WORK PACKAGES CONSIST OF THE FOLLOWING:

Page No.	Change No. *
Warning a–Warning b0
A0
B blank0
i0
ii blank0
iii–vii0
viii blank0
WP 0001 00–WP 0062 000
Index 1–Index 30
Index 4 blank0

*Zero in this column indicates original page.

*Supersedes copy dated 28 August 2001

HEADQUARTERS,
DEPARTMENT OF THE ARMY
WASHINGTON, D.C., 21 July 2005

DIRECT SUPPORT AND GENERAL SUPPORT MAINTENANCE MANUAL INCLUDING REPAIR PARTS AND SPECIAL TOOLS LIST (RPSTL)

FOR

ENGINE, DIESEL: 6 CYLINDER IN-LINE
TURBOCHARGED, CUMMINS MODEL NTC-400

BIG CAM I

(NSN 2815-01-082-8125)

BIG CAM III

(NSN 2815-01-142-2745)

ALL TRUCKS M915-M920 AND M915A4 CAN BE EQUIPPED WITH EITHER BIG CAM I OR BIG CAM III ENGINES.

REPORTING ERRORS AND RECOMMENDING IMPROVEMENTS

You can help improve this publication. If you find any mistakes or if you know of a way to improve the procedures, please let us know. Submit your DA Form 2028 (Recommended Changes to Publications and Blank Forms), through the Internet, on the Army Electronic Product Support (AEPS) website. The Internet address is <http://aeps.ria.army.mil>. If you need a password, scroll down and click on "ACCESS REQUEST FORM." The DA Form 2028 is located in the ONLINE FORMS PROCESSING section of the AEPS. Fill out the form and click on SUBMIT. Using this form on the AEPS will enable us to respond quicker to your comments and better manage the DA Form 2028 program. You may also mail, fax or E-mail your letter or DA Form 2028 direct to: AMSTA-LC-CI Tech Pubs, TACOM-RI, 1 Rock Island Arsenal, Rock Island, IL 61299-7630. The E-mail address is TACOM-TECH-PUBS@ria.army.mil. The fax number is DSN 793-0726 or Commercial (309) 782-0726.

DISTRIBUTION STATEMENT A: Approved for public release; distribution is unlimited.

TABLE OF CONTENTS

	<u>Work Package/Page No.</u>
How to Use This Technical Manual (TM)	v
CHAPTER 1 GENERAL INFORMATION, EQUIPMENT DESCRIPTION, AND THEORY OF OPERATION	
General Information	WP 0001 00-1
Equipment Characteristics, Capabilities, and Features	WP 0002 00-1
Theory of Operation	WP 0003 00-1
CHAPTER 2 TROUBLESHOOTING PROCEDURES	
Engine Troubleshooting	WP 0004 00-1
CHAPTER 3 MAINTENANCE INSTRUCTIONS	
Preventive Maintenance Checks and Services (PMCS) Introduction	WP 0005 00-1
Preventive Maintenance Checks and Services (PMCS) Instructions	WP 0006 00-1
Big Cam I Engine Removal	WP 0007 00-1
Big Cam III Engine Removal	WP 0008 00-1
Mounting Engine on Maintenance Stand	WP 0009 00-1
Engine Accessories Removal	WP 0010 00-1
Cylinder Head and Cylinder Head Components Removal	WP 0011 00-1
Cylinder Block Components Removal	WP 0012 00-1
Cylinder Block	WP 0013 00-1
Cylinder Head	WP 0014 00-1
Vibration Damper and Crankshaft Pulley Cleaning and Inspection	WP 0015 00-1
Crankshaft Cleaning and Inspection	WP 0016 00-1
Flexplate, Flywheel, Flywheel Housing, and Rear Cover Cleaning and Inspection	WP 0017 00-1
Pistons, Connecting Rods, and Bearings	WP 0018 00-1
Camshaft, Camshaft Followers, and Push Rods	WP 0019 00-1
Rocker Levers and Rocker Lever Housing	WP 0020 00-1
Oil Cooler	WP 0021 00-1
Oil Pan, Dipstick, Oil Suction Tubes, and Breather Tube	WP 0022 00-1
Oil Pump	WP 0023 00-1
Air Aftercooler	WP 0024 00-1
Exhaust Manifold	WP 0025 00-1
Turbocharger	WP 0026 00-1
Turbocharger HT-3B	WP 0027 00-1
Front Gear Cover	WP 0028 00-1
Accessory Drive and Accessory Drive Pulley	WP 0029 00-1
Engine Retarder	WP 0030 00-1

TABLE OF CONTENTS (Contd)

Work Package/Page No.

CHAPTER 3 MAINTENANCE INSTRUCTIONS (Contd)

Air Compressor	WP 0031 00-1
Fuel Injector	WP 0032 00-1
Fuel Pump Disassembly	WP 0033 00-1
Solenoid Valve	WP 0034 00-1
Fuel Damper and Head	WP 0035 00-1
Fuel Gear Pump	WP 0036 00-1
Fuel Pump Governor Spring	WP 0037 00-1
Fuel Pump Front Cover and Governor	WP 0038 00-1
Fuel Pump Main Housing	WP 0039 00-1
Fuel Pump Assembly	WP 0040 00-1
Water Pump	WP 0041 00-1
Cylinder Block Components Installation	WP 0042 00-1
Cylinder Head and Cylinder Head Components Installation ...	WP 0043 00-1
Fuel Pump Testing and Calibration	WP 0044 00-1
Engine Accessories Installation	WP 0045 00-1
Removing Engine from Maintenance Stand	WP 0046 00-1
Engine Testing	WP 0047 00-1
Big Cam III Engine Installation	WP 0048 00-1
Big Cam I Engine Installation	WP 0049 00-1
Big Cam III Modification Kit Installation Instructions	WP 0050 00-1
General Maintenance Instructions	WP 0051 00-1
Illustrated List of Manufactured Items	WP 0052 00-1
Torque Limits	WP 0053 00-1
Wear Limits	WP 0054 00-1

CHAPTER 4 SUPPORTING INFORMATION

References	WP 0055 00-1
Repair Parts Introduction	WP 0056 00-1
Repair Parts	WP 0057 00-1
Repair Parts and Special Tools List (RPSTL)	WP 0058 00-1
National Stock Number (NSN) Index	WP 0059 00-1
Expendable and Durable Items	WP 0060 00-1
Tools and Special Tools	WP 0061 00-1
Mandatory Replacement Parts	WP 0062 00-1

Index	Index-1
-------------	---------

HOW TO USE THIS TECHNICAL MANUAL (TM)

INTRODUCTION

This section explains the basic organization, contents, format, and special features of this Technical Manual (TM). After reading this section, spend some time reviewing the TM to familiarize yourself with the contents and layout. This will enable you to locate information easily and reduce the time needed to complete required procedures.

ORGANIZATION AND CONTENTS

This TM is divided into four main chapters. Chapter 1 presents general information and preliminary data; chapter 2 contains troubleshooting procedures; chapter 3 includes maintenance instructions; and chapter 4 provides supporting tool, equipment, and parts information. The following table provides an overview of the material contained in each chapter of this TM.

Table 1. TM Contents

Chapter 1	<ul style="list-style-type: none"> • Basic information about the component, along with general guidelines and criteria for inspection and repair or replacement • Detailed equipment description and data • Theory of operation
Chapter 2	<ul style="list-style-type: none"> • Detailed troubleshooting procedures
Chapter 3	<ul style="list-style-type: none"> • Detailed maintenance instructions for disassembly, inspection, repair or replacement, and assembly
Chapter 4	<ul style="list-style-type: none"> • Supporting information covering repair parts, expendable and durable items, tools and special tools, and mandatory replacement parts list

You can locate specific information in the TM by using either the Table of Contents, located at the front of the TM, or the alphabetical subject Index, located at the back of the TM.

HOW TO USE THIS TECHNICAL MANUAL (TM) (Contd)

FORMAT

Work Package (WP) Format

Each chapter in this TM is divided into WPs, which group data into stand-alone informational or task-oriented units. Here are some important things to know about the WP format:

- Each WP has its own identification number, which appears in the upper right corner of each page. WPs are numbered sequentially throughout the manual.
- Each WP starts with page number 1. Page numbers appear at the bottom of the pages, following the WP number.
- Informational WPs begin with a listing of the specific topics covered, in the order in which they appear in the WP. This listing provides a quick overview of each WP and enables you to locate specific information easily.
- Each task-oriented WP begins with an Initial Setup list that identifies all tools, mandatory replacement parts, personnel, and other materials needed to complete the procedure in the WP. Before you begin a procedure, review the Initial Setup information to ensure that all requirements have been met.
- Task-oriented WPs (maintenance procedures) appear in the manual in the order of logical work sequence. This format makes the TM easy to follow and helps improve efficiency as you progress through the procedures.

Text and Illustration Modular Layout

Throughout this TM, maintenance procedures are set up in two-page modular layouts. This means that illustrations appear either on the same page as, or on the page facing, the step you are performing. This feature eliminates the need to search for illustrations that correlate with each procedural step.

In addition, procedural text is cross-referenced to numerical callouts in the illustrations, helping you immediately identify and locate specific parts mentioned. Callout numbers referencing the illustrations appear in parentheses in the text.

HOW TO USE THIS TECHNICAL MANUAL (TM) (Contd)

SPECIAL FEATURES

Illustration Features

This TM utilizes a variety of illustration methods, such as locator views and exploded views, to help you locate and identify parts easily. Each illustration is identified by a title printed below it.

The illustrations contain numerical callouts to identify parts, components, etc. mentioned in the text. Numerical callouts generally appear in clockwise order in the illustrations, beginning at the 11 o'clock position.

A special feature of this TM is that callout numbers for mandatory replacement parts are circled in the illustrations. This visually distinguishes mandatory replacement parts from those that may be repairable or otherwise reusable.

Supporting Information

The WPs at the end of this TM contain supporting information that supports the procedures in the TM. This information is cross-referenced in the Initial Setup list of each maintenance WP. The following supplemental information is included in this TM:

- References—All publications referenced in this TM
- Repair Parts Introduction—Specific introduction information regarding repair parts
- Repair Parts—Source, Maintenance, and Recoverability (SMR) code; NSN; CAGEC; P/N; and quantity for all parts required for the procedures in this TM
- Expendable and Durable Items—National Stock Number (NSN), description, Commercial and Governments Entity Code (CAGEC), Part Number (P/N), and description for all expendable and durable items necessary to operate or maintain the equipment used in this TM
- Tools and Special Tools—Name, P/N, and NSN for common and special tools required for the procedures in this TM
- Mandatory Replacement Parts—Names, P/N, and NSN for all parts that must be replaced during overhaul of the component; also includes cross-references to figure and item numbers in the Repair Parts WP

CHAPTER 1

**GENERAL INFORMATION, EQUIPMENT DESCRIPTION,
AND THEORY OF OPERATION**

FOR

**ENGINE, DIESEL
CUMMINS MODEL NTC-400**

**M915, M915A1, M915A4,
M916, M920 VEHICLES**

CHAPTER 1

GENERAL INFORMATION, EQUIPMENT DESCRIPTION, AND THEORY OF OPERATION

<u>Work Package Title</u>	<u>Work Package/Page No.</u>
General Information	WP 0001 00-1
Equipment Characteristics, Capabilities, and Features	WP 0002 00-1
Theory of Operation	WP 0003 00-1

**DIRECT SUPPORT AND GENERAL SUPPORT
MAINTENANCE MANUAL
INCLUDING REPAIR PARTS AND SPECIAL TOOLS LIST (RPSTL)**

FOR

M915, M915A1, M915A4, M916, M920 VEHICLES

NSN 2815-01-082-8125	P/N NTC400-3652-02	CUMMINS NTC-400 BIG CAM I DIESEL ENGINE W/CONTAINER
NSN 2815-01-142-2745	P/N 11669835	CUMMINS NTC-400 BIG CAM III DIESEL ENGINE W/CONTAINER

GENERAL INFORMATION

THIS WORK PACKAGE (WP) COVERS:

Scope; Maintenance Forms, Reporting Equipment Improvement Recommendations (EIRs); Corrosion Prevention and Control (CPC); Destruction of Army Materiel to Prevent Enemy Use; Preparation for Storage or Shipment; Warranty Information; List of Abbreviations; Quality of Material; Safety, Care and Handling.

SCOPE

This manual contains repair procedures and supplemental data for the Cummins NTC-400 six-cylinder, in-line, turbocharged diesel engine. The repair procedures in this manual are for use at direct support and general support maintenance levels. All information contained in this manual applies to both Big Cam I and Big Cam III engines except where differences are specifically noted.

MAINTENANCE FORMS

Department of the Army forms and procedures used for equipment maintenance will be those prescribed by DA PAM 738-750, Functional Users Manual for The Army Maintenance Management System (TAMMS).

REPORTING EQUIPMENT IMPROVEMENT RECOMMENDATIONS (EIR'S)

If your Cummins NTC-400 six cylinder diesel engine needs improvement, let us know. Send us an EIR. You, the user, are the only one who can tell us what you don't like about your equipment. Let us know what you don't like about the design or performance. The preferred method for submitting Quality Deficiency Reports (QDRs) is through the Army Electronic Product Support (AEPS) website under the Electronic Deficiency Reporting System (EDRS). The web address is: <https://aeps.ria.army.mil>. This is a secured site requiring a password that can be applied for on the front page of the website. If the above method is not available to you, put it on an SF 368, Product Quality Deficiency Report (PQDR), and mail it to us at: Department of the Army, U.S. Army Tank-automotive and Armaments Command, ATTN: AMSTA-LC-CHMM, 6501 E. 11 Mile Road, Mail Stop 420, Warren, MI 48397-5000. We'll send you a reply.

GENERAL INFORMATION (Contd)

CORROSION PREVENTION AND CONTROL (CPC)

Corrosion Prevention and Control (CPC) of Army materiel is a continuing concern. It is important that any corrosion problem with this item be reported so that the problem can be corrected and improvements made to prevent the problem in the future.

While corrosion is typically associated with rusting of metals, it can also include deterioration of other materials, such as rubber and plastic. Unusual cracking, softening, swelling, or breaking of these materials may be a corrosion problem.

If a corrosion problem is identified, it can be reported using an SF 368, Quality Deficiency Report. Use of key words, such as corrosion, rust, deterioration, or cracking, will ensure that the information is identified as a CPC problem.

The form should be submitted to the address specified in DA PAM 738-750, Functional Users Manual for The Army Maintenance Management System (TAMMS).

DESTRUCTION OF ARMY MATERIEL TO PREVENT ENEMY USE

Procedures for destruction of Army equipment to prevent enemy use can be found in TM 750-244-6.

PREPARATION FOR STORAGE OR SHIPMENT

Information concerning storage or shipment of equipment can be found in TM 740-90-1. Additional information concerning storage of Cummins NTC-400 engine can be found in Chapter 3, Maintenance Instructions.

WARRANTY INFORMATION

The Cummins diesel engine (model NTC-400) is warranted in accordance with TB 9-2300-295-15/21. The warranty starts on the date found in block 23, DA Form 2408-9. Report all defects in material or workmanship to your supervisor, who will take appropriate action.

LIST OF ABBREVIATIONS

AFC Air Fuel Control	kPakilopascal
ASA Air Signal Attenuator	Lliter
BHPBrake Horsepower	lb-ftpound foot
CCelsius	lb/hrpounds per hour
CFMcubic feet per minute	lb-inpound inch
CPC Corrosion Prevention and Control	N•mNewton meter
cu in.cubic inch	pphpounds per hour
EIREquipment Improvement Recommendations	PQDRProduct Quality Deficiency Report
EPAEnvironmental Protection Agency	PTPressure Timed
ffoot	psipounds per square inch
FFahrenheit	rpmrevolutions per minute
ft altfeet altitude	STE/ICESimplified Test Equipment for Internal Combustion Engines
QDRQuality Deficiency Report	TAMMSThe Army Maintenance Management System
HgMercury	TMTechnical Manual
hphorsepower	WPWork Package
in.inch		
kgkilogram		

GENERAL INFORMATION (Contd)

QUALITY OF MATERIAL

Material used for replacement, repair, or modification must meet the requirements of this manual. If quality of material requirements are not stated in this manual, the material must meet the requirements of the drawings, standards, specifications, or approved engineering change proposals applicable to this Cummins engine.

SAFETY, CARE, AND HANDLING

Adequate safety precautions will be provided for the performance of maintenance operations. These precautions will include safety in work environment, selection and usage of equipment, and procedures provided for performing all operations. Inspection, which follows completion of maintenance procedures, will ensure equipment compliance with applicable safety standards.

Supplies and materials such as cleaning fluids, sealers, adhesives, oils, and other products used in this manual may be dangerous or harmful if safety precautions are not observed. Read manufacturers' warnings and cautions on product labels before using and observe all recommended safety precautions.

Ensure proper procedures are followed during lifting of heavy items. Follow all warnings and cautions identified in this manual.

DIRECT SUPPORT AND GENERAL SUPPORT MAINTENANCE MANUAL INCLUDING REPAIR PARTS AND SPECIAL TOOLS LIST (RPSTL)

FOR

M915, M915A1, M915A4, M916, M920 VEHICLES

NSN 2815-01-082-8125	P/N NTC400-3652-02	CUMMINS NTC-400 BIG CAM I DIESEL ENGINE W/CONTAINER
NSN 2815-01-142-2745	P/N 11669835	CUMMINS NTC-400 BIG CAM III DIESEL ENGINE W/CONTAINER

EQUIPMENT CHARACTERISTICS, CAPABILITIES, AND FEATURES

The Cummins NTC-400 diesel engine is a turbocharged, liquid-cooled, overhead valve, four-cycle engine with an in-line, six-cylinder design. The NTC-400 engine has a compression ratio of 13.5:1 (Big Cam I) and 14.0:1 (Big Cam III), and develops 400 horsepower at 2100 rpm. Peak torque is 1150 lb-ft at 1500 rpm (Big Cam I) and 1300 lb-ft at 1300 rpm (Big Cam III).

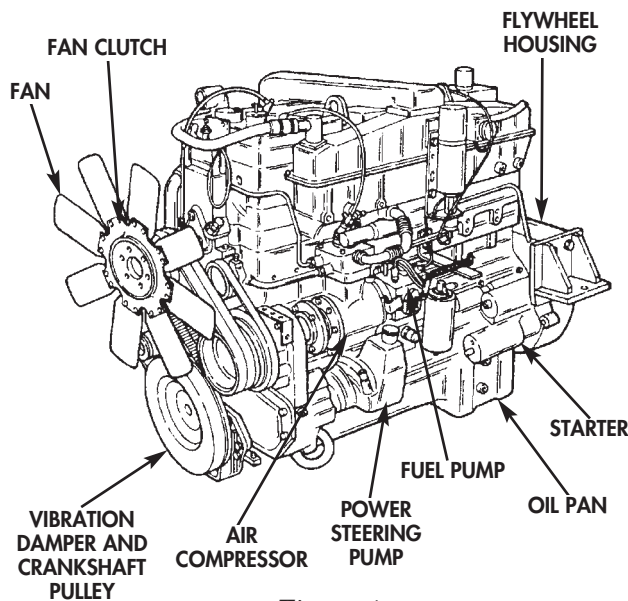


Figure 1.
Cummins NTC-400 Diesel Engine—Left Side.

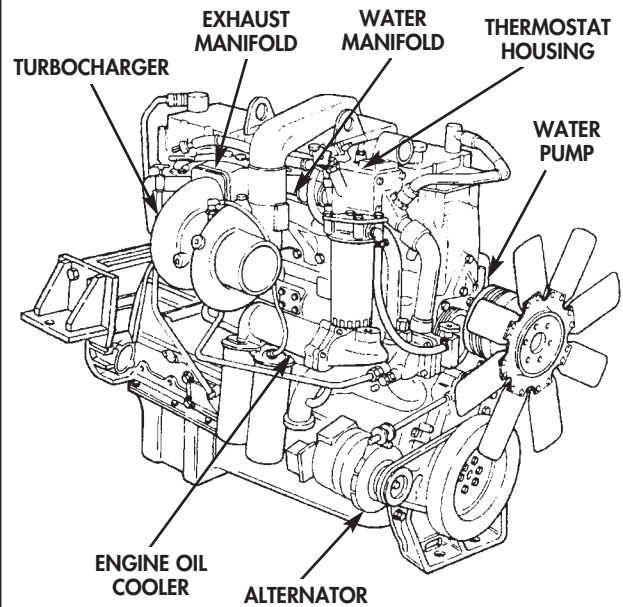


Figure 2.
Cummins NTC-400 Diesel Engine—Right Side.

EQUIPMENT CHARACTERISTICS, CAPABILITIES, AND FEATURES (Contd)

LOCATION AND DESCRIPTION OF MAJOR COMPONENTS

Table 1. Engine Features and Characteristics.

ENGINE FEATURE/CHARACTERISTIC	BIG CAM I	BIG CAM III
Camshaft	2-1/2-inch diameter camshaft with gear drive controlling all valve and injector movement. Made of induction-hardened alloy steel. Camshaft followers are roller-type.	
Connecting Rods	Drop-forged, rifle-drilled for pressure lubrication.	
Crankshaft	High-tensile steel forging. Bearing journals and fillets-induction hardened. Fully counterweighted.	
Cylinder Block	Alloy cast iron with removable wet liners.	
Cylinder Heads	Each head serves two cylinders. Drilled fuel supply and return lines. High temperature inserts on exhaust valve seats.	
Turbocharger	Model T-50.	Model HT-3B has a redesigned compressor wheel, compressor housing, turbine wheel and shaft, bearing housing assembly, location of oil inlet line, and V-bands.
Exhaust Manifold	Conventional log-type.	Pulse-type for less restriction.
Fuel System	Integral flywheel-type governor.	
Injectors	Camshaft actuated top-stop type.	
Intake Manifold	Conventional aftercooler.	Triple-pass water aftercooler.
Lubrication Oil Cooler	Conventional oil cooler and filter with separately mounted bypass oil filter on engine firewall. Demand flow automatically regulates oil pressure and routes engine coolant through engine oil cooler twice.	Engine and cooler core are made of cast aluminum and incorporates mounting adapters for spin-on type full-flow and bypass oil filters, also incorporates a bypass valve and pressure sending unit.
Oil Pan	Made of cast aluminum.	Made of stamped steel.
Water Transfer Tube	Made of cast iron.	Made of stamped, welded steel.

EQUIPMENT CHARACTERISTICS, CAPABILITIES, AND FEATURES (Contd)

EQUIPMENT DATA

Manufacturer Cummins Engine Company, Inc.
 Model..... NTC-400
 Type..... 4-cycle, turbocharged diesel,
 compression ignition

DIMENSIONS

Length 58.88 in. (149.6 cm)
 Width..... 33.63 in. (85.4 cm)
 Height 50.91 in. (129.3 cm)
 Net Weight, Dry..... 2,600 lb (1,180.4 kg)

CYLINDERS

Number..... 6
 Arrangement..... In-line
 Firing Order..... 1-5-3-6-2-4
 Bore..... 5.5 in. (14 cm)
 Stroke 6 in. (15.2 cm)
 Displacement 855 cu-in. (14 L)
 Compression Ratio:
 Big Cam I..... 13.5:1
 Big Cam III 14.0:1

GOVERNED SPEED

Full Load 2100 rpm
 No Load 2460 rpm
 Idle Speed..... 600 rpm

LUBRICATION SYSTEM

Type..... Force-fed
 Operating Pressure (Normal):
 Big Cam I 50–70 psi (345–483 kPa)
 Big Cam III 35–45 psi (241–310 kPa)
 Operating Pressure (Minimum) 15 psi (100 kPa) @ idle
 System Capacity Including Bypass Filter:
 Big Cam I..... 46 qt (43.5 L)
 Big Cam III 44 qt (41.6 L)
 Operating Temperature (Normal) 200–250° F (93–121° C)
 Oil Pump Gear-type

EQUIPMENT CHARACTERISTICS, CAPABILITIES, AND FEATURES (Contd)

COOLING SYSTEM

Type	Liquid with fan and radiator
Operating Temperature (Normal)	175–195° F (79–91° C)
Thermostat	1

PERFORMANCE HEAD

Maximum Torque:	
Big Cam I	1150 lb-ft @ 1500 rpm
Big Cam III	1300 lb-ft @ 1300 rpm
Maximum Output	400 BHP
Piston Speed @ 2100 rpm	2100 ft/min
Maximum No Load Governed Speed	2460 rpm
Maximum Approved Altitude, Transient Mode	12,000 ft (3658 m)
Maximum Approved Altitude, Continuous Operation	6000 ft (1829 m)
Ambient Air Temperature Above Which Output Should be Limited	
	100° F (37.8° C)
Air Flow @ 400 hp @ 2100 rpm	985 CFM
Exhaust Flow @ 400 hp @ 2100 rpm	2320 CFM
Nominal Fuel Consumption @ 2100 rpm	144 lb/hr
Nominal Fuel Consumption @ 500 rpm (Peak Torque)	116 lb/hr
Maximum Fuel Flow to Pump @ 2100 rpm	485 lb/hr
Maximum Allowable Restriction to Pump:	
Clean Filter	4.0 in. Hg
Dirty Filter	8.0 in. Hg
Maximum Allowable Return Line Restriction	2.5 in. Hg

**DIRECT SUPPORT AND GENERAL SUPPORT
MAINTENANCE MANUAL
INCLUDING REPAIR PARTS AND SPECIAL TOOLS LIST (RPSTL)**

FOR

M915, M915A1, M915A4, M916, M920 VEHICLES

**NSN 2815-01-082-8125 P/N NTC400-3652-02 CUMMINS NTC-400 BIG CAM I DIESEL ENGINE
W/CONTAINER**

**NSN 2815-01-142-2745 P/N 11669835 CUMMINS NTC-400 BIG CAM III DIESEL ENGINE
W/CONTAINER**

THEORY OF OPERATION

**ENGINE FEATURES, ENGINE OIL SYSTEM COMPONENTS AND PIPING, ENGINE OIL MONITORING SYSTEM,
ENGINE RETARDER BRAKE CONTROL, ENGINE SPEED CONTROLS**

SCOPE

This Work Package provides you with information regarding theory of operation for the Cummins NTC-400 diesel engine.

THEORY OF OPERATION (Contd)

ENGINE FEATURES

The Cummins NTC-400 diesel engine is used on all M915 through M920, M915A1, and M915A4 trucks. It is a turbocharged, liquid-cooled, overhead valve, four-cycle engine of in-line, six-cylinder design. The NTC-400 engine has a compression ratio of 13.5:1 (Big Cam I) and 14.0:1 (Big Cam III) and develops 400 horsepower at 2100 rpm. Peak torque is 1150 lb-ft at 1500 rpm (Big Cam I) and 1300 lb-ft at 1300 rpm (Big Cam III).

The following engine characteristics and features apply to both Big Cam I and Big Cam III engines, except where differences are noted.

Camshaft: 2 1/2-inch diameter camshaft with gear drive controlling all valve and injector movement. Made of induction hardened alloy steel. Camshaft followers are roller-type.

Connecting Rods: Drop-forged, rifle-drilled for pressure lubrication.

Crankshaft: High-tensile steel forging. Bearing journals and fillets are induction hardened. Fully counterweighted.

Cylinder Block: Alloy cast iron with removable wet liners.

Cylinder Heads: Each head serves two cylinders. Drilled fuel supply and return lines. High temperature inserts on exhaust valve seats.

Turbocharger: Model T-50 (Big Cam I); Model T-46-B (Big Cam III) has a redesigned compressor wheel, compressor housing, turbine wheel and shaft, bearing housing assembly, location of oil inlet line, and V-bands.

Exhaust Manifold: Conventional log-type (Big Cam I). Pulse-type for less restriction (Big Cam III).

Fuel System: Integral flywheel-type governor.

Injectors: Camshaft actuated top stop-type.

Intake Manifold: Conventional aftercooler (Big Cam I); triple-pass water aftercooler (Big Cam III).

Lubrication Oil Cooler: Conventional oil cooler and filter with separately mounted bypass oil filter on engine firewall (Big Cam I). Demand flow automatically regulates oil pressure and routes engine coolant through engine oil cooler twice.

Engine and cooler cores are made of cast aluminum and incorporate mounting adapters for spin-on-type full-flow and bypass oil filters; also incorporate a bypass valve and pressure sending unit (Big Cam III).

Oil Pan: Made of cast aluminum (Big Cam I). Made of stamped steel (Big Cam III).

Water Transfer Tube: Made of cast iron (Big Cam I). Made of stamped, welded steel (Big Cam III).

THEORY OF OPERATION (Contd)

ENGINE OIL SYSTEM COMPONENTS AND PIPING

Breather Tube (1) – Allows fumes from hot oil to escape.

Oil Filler (2) – Located in front rocker arm cover. Used for replenishing oil supply.

Oil Pump (3) – Circulates oil through engine to provide cooling and lubrication.

Oil Cooler (4) – Coolant circulates through internal tubes of cooler and carries away heat from engine oil.

Primary Oil Filter (5) – Throwaway filter removes dirt and foreign particles from oil.

Bypass Oil Filter (6) – Throwaway filter provides filtration when primary filter is clogged or damaged.

Oil Return Line (7) – Carries return oil from turbocharger to engine block.

Oil Level Dipstick (8) – Indicates engine oil level.

Oil Supply Line (9) – Carries oil under pressure to cool and lubricate turbocharger.

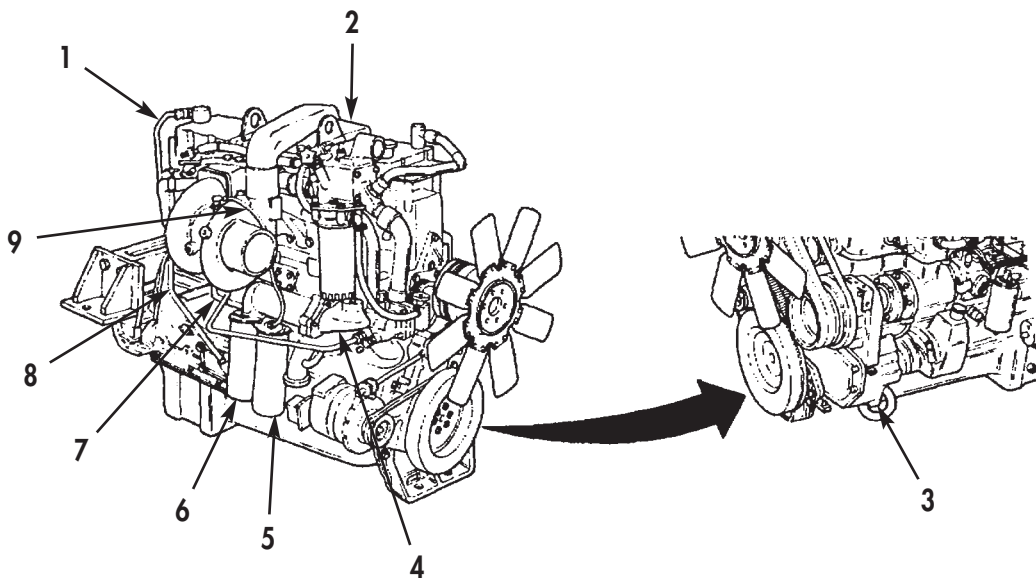


Figure 1. Engine Oil System Components and Piping.

THEORY OF OPERATION (Contd)

ENGINE OIL MONITORING SYSTEM

Battery Pack – Consists of four 12-volt, maintenance-free batteries. Two batteries are wired in parallel in each set. Each set is connected in series for 24-volt output. Battery pack is used for both 12-volt and 24-volt output.

Ignition Switch – Supplies 24-volt power to relay (RY-9), which in turn provides 12-volt power to electrical system, including oil pressure gauge and warning lamp circuits.

Relay (RY-9) – Energized by 24-volt power from ignition switch. When energized, RY-9 supplies 12-volt power to circuit breaker (CB-2).

Circuit Breaker (CB-2) – Protects electrical components of oil system by opening circuit when load exceeds 20 amperes. May be manually reset by pressing CB-2 button in.

Oil Pressure Gauge – Activated by electrical signal from oil pressure sending unit. Indicates engine oil pressure.

Oil Pressure Sending Unit – Provides electrical signal to oil pressure gauge to indicate engine oil pressure.

Oil Warning Lamp – Indicator lamp is activated by 12-volt power from pressure switch when engine oil pressure drops below 5 psi.

Pressure Switch – Closes to supply 12-volt power to oil warning lamp when oil pressure drops below 5 psi.

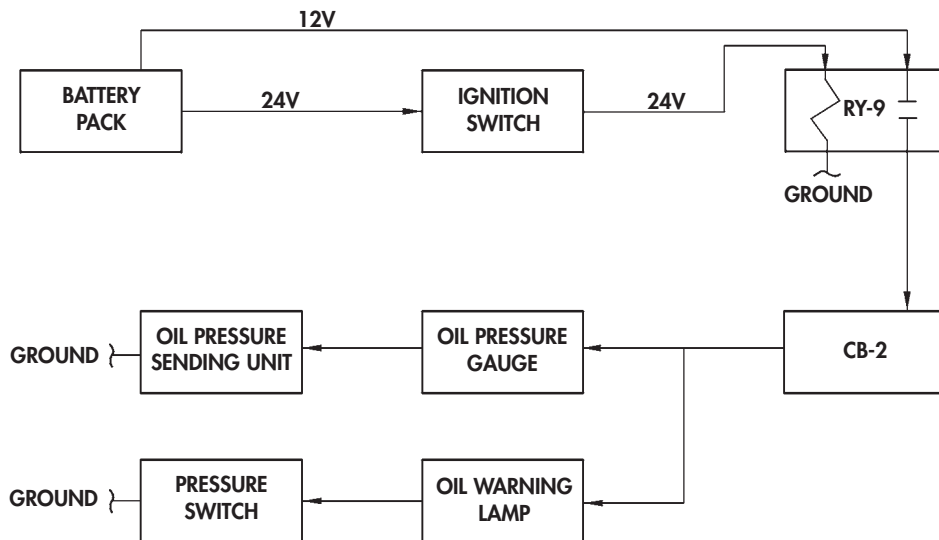


Figure 2. Engine Oil Monitoring System.

THEORY OF OPERATION (Contd)

ENGINE RETARDER BRAKE CONTROL

Battery Pack – Consists of four 12-volt, maintenance-free batteries. Two batteries are wired in parallel in each set. Each set is connected in series for 24-volt output. Battery pack is used for both 12-volt and 24-volt output.

Ignition Switch – Supplies 24-volt power to relay (RY-9), which in turn provides 12-volt power to electrical system, including engine retarder brake circuit.

Relay (RY-9) – Energized by 24-volt power from ignition switch. When energized, RY-9 supplies 12-volt power to circuit breaker (CB-2).

Circuit Breaker (CB-2) – Protects electrical components of engine retarder brake circuit by opening when load exceeds 20 amperes. May be manually reset by pressing CB-2 button in.

Foot Switch – Allows driver to activate engine brake circuit with left foot. When depressed, switch supplies 12-volt power through CB-2, throttle switch, and engine retarder switch to energize selected solenoid valve(s).

Throttle Switch – Switch is open when accelerator pedal is pressed down to prevent activation of engine retarder brake. Activating arm on fuel pump lever closes switch when accelerator is disengaged.

Engine Retarder Switch – Three-position switch allows driver to select engine braking for two cylinders (LOW), four cylinders (MED), or six cylinders (HIGH). Depressing pedal-actuated foot switch completes 12-volt power circuit to energize one, two, or three solenoids.

Solenoid Valves – Operate engine braking mechanism when activated.

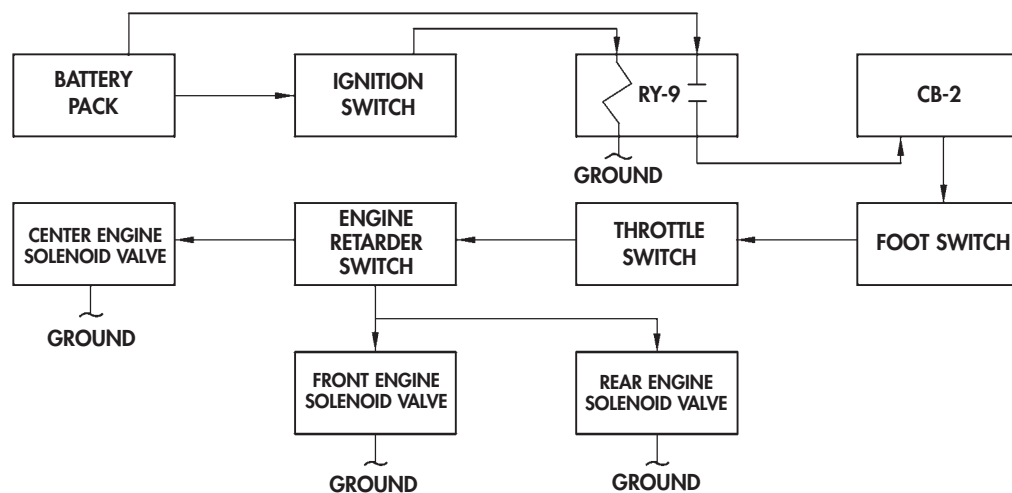


Figure 3. Engine Retarder Brake Controls.

THEORY OF OPERATION (Contd)

ENGINE SPEED CONTROLS

Hand Throttle (1) – Allows manual control of engine rpm. Throttle motion is transferred by cable to engine mounted pivot lever (6).

Throttle Cable (2) – Flex cable from hand throttle to engine-mounted pivot lever (6).

Accelerator Pedal (3) – Connected by mechanical linkage to under-cab pivot lever (4).

Pivot Lever (4) – Mechanical linkage that connects accelerator pedal to accelerator rod.

Accelerator Rod (5) – Connects accelerator pedal and throttle linkage to accelerator lever on fuel pump.

Engine Mounted Pivot Lever (6) – Connects under-dash hand throttle cable (ALL) and winch throttle cable (M916 and M920) to accelerator rod.

Accelerator Lever (7) – Controls flow of fuel through fuel pump, setting engine speed.

Fuel Control Return Spring (8) – Returns accelerator lever to normal position when hand throttle and accelerator pedal are not engaged.

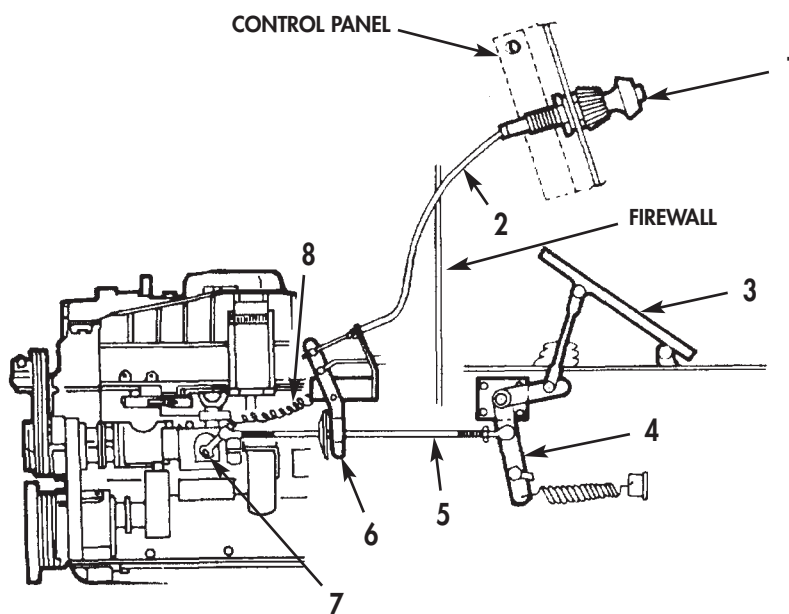


Figure 4. Engine Speed Controls.

CHAPTER 2

TROUBLESHOOTING PROCEDURES

FOR

ENGINE, DIESEL

CUMMINS MODEL NTC-400

M915, M915A1, M915A4,

M916, M920 VEHICLES

CHAPTER 2

TROUBLESHOOTING PROCEDURES

Work Package Title

Work Package/Page No.

Engine Troubleshooting WP 0004 00-1

DIRECT SUPPORT AND GENERAL SUPPORT MAINTENANCE MANUAL INCLUDING REPAIR PARTS AND SPECIAL TOOLS LIST (RPSTL)

FOR

M915, M915A1, M915A4, M916, M920 VEHICLES

NSN 2815-01-082-8125	P/N NTC400-3652-02	CUMMINS NTC-400 BIG CAM I DIESEL ENGINE W/CONTAINER
NSN 2815-01-142-2745	P/N 11669835	CUMMINS NTC-400 BIG CAM III DIESEL ENGINE W/CONTAINER

ENGINE TROUBLESHOOTING

SCOPE

This Work Package (WP) contains troubleshooting information to diagnose and correct engine malfunctions for Big Cam I and Big Cam III engines. Use this information in conjunction with troubleshooting procedures in TM 9-2320-273-20 and TM 9-2320-273-34 for Big Cam I, and TM 9-2320-283-20 and TM 9-2320-283-34 for Big Cam III. For further engine troubleshooting information, refer to the Cummins Troubleshooting and Repair Manual, NT 855 Engines, Bulletin No. 3810298-00.

Troubleshooting procedures are organized by malfunction, followed by a test or inspection to determine the corrective action required. Each step has a corrective action, along with appropriate WP references. Steps listed under each malfunction are in the order in which the causes are most likely to occur.

GUIDELINES

Observe the following guidelines when performing troubleshooting procedures.

WARNING

Operating a deadlined vehicle without preliminary inspection will cause further damage to a malfunctioning component and possible injury to personnel.

1. Check all tags, service request forms, and vehicle logbooks for repair history. This may provide information as to the source of the problem.
2. Debrief the operator (if possible) for a general description of the problem, then attempt to verify the fault.
3. When troubleshooting, always check the easiest and most obvious things first. This simple rule saves time and trouble. For example, low power complaints are often the result of loose throttle linkage, dirty fuel, or clogged air filters, and excessive oil consumption is often the result of leaky gaskets or loose line connections.
4. Double-check before disassembly. The source of many engine problems can be traced to more than one part in a system. For example, excessive fuel consumption may not be caused by the fuel pump alone. Instead, the trouble could be a clogged air cleaner or a restricted exhaust passage causing severe back pressure.

ENGINE TROUBLESHOOTING (Contd)*Table 1. Engine Troubleshooting.*

MALFUNCTION	TEST OR INSPECTION	CORRECTIVE ACTION
1. ENGINE WILL NOT CRANK	<ul style="list-style-type: none"> a. Remove rocker covers and rotate engine by attaching a socket and breaker bar to accessory drive nut. b. Test for mechanical or hydraulic seizure. c. Check for bent pushrod(s) and valve(s) not opening or closing. 	<ul style="list-style-type: none"> b. If valve fails to open or close, manually open valve with 3/4-in. wrench. If valve(s) are seized, remove corresponding cylinder head (WP 0011 00). Remove fuel injectors (WP 0011 00). Turn engine over several times to displace liquid from cylinders through injector openings. If engine can be turned freely after all liquids have been displaced, install injectors. If engine cannot be turned over freely by hand, disassemble engine and replace defective parts. c. Replace pushrods and valves if damaged.
2. ENGINE CRANKS BUT FAILS TO START	<ul style="list-style-type: none"> a. Test for broken fuel gear pump driveshaft. b. Test for dirty or damaged injectors. c. Test for defective fuel solenoid valve. d. Test for faulty fuel pump. (Disconnect fuel outlet hose; crank engine to see if fuel comes out.) e. Test for incorrect injector adjustment. f. Test for incorrect valve clearance. g. Test for incorrect injector timing. 	<ul style="list-style-type: none"> a. Replace fuel gear pump drive shaft if damaged (WP 0036 00). b. Replace injectors (WP 0011 00 and WP 0043 00). c. Replace fuel solenoid valve (WP 0034 00). d. Replace fuel pump (WP 0010 00 and WP 0040 00). e. Adjust injectors (WP 0043 00). f. Adjust valve(s) (WP 0043 00). g. Adjust injector system timing (WP 0043 00).
3. ENGINE STARTS, MOTOR OPERATES BUT DOES NOT ENGAGE THE RING GEAR	<ul style="list-style-type: none"> a. Inspect for defective starter pinion gear. b. Inspect for defective ring gear. 	<ul style="list-style-type: none"> a. Replace starter pinion gear (TM 9-2320-283-34). b. Replace ring gear (WP 0007 00 and WP 0049 00).

ENGINE TROUBLESHOOTING (Contd)*Table 1. Engine Troubleshooting (Contd).*

MALFUNCTION	TEST OR INSPECTION	CORRECTIVE ACTION
4. ENGINE STOPS	<ul style="list-style-type: none"> a. Check if engine is overheated. b. Check for loose fuel solenoid wire and defective fuel solenoid valve. c. Check for faulty fuel pump. 	<ul style="list-style-type: none"> a. See malfunction 6. b. Replace fuel solenoid valve (WP 0033 00). c. Replace fuel pump (WP 0010 00).
5. ENGINE FAILS TO STOP	<ul style="list-style-type: none"> a. Check for stuck fuel solenoid valve. b. Check for turbocharger oil seal leak in compressor end. 	<ul style="list-style-type: none"> a. Replace fuel solenoid valve (WP 0033 00). b. Replace compressor oil seal (WP 0026 00 and WP 0027 00).
6. ENGINE OVERHEATS	Check for leaking or noisy water pump.	Repair water pump (WP 0041 00).
7. EXCESSIVE EXHAUST SMOKE	<ul style="list-style-type: none"> a. Check for incorrect injector adjustment. b. Check for defective fuel injector(s). c. Check for blocked fuel return line in fuel system. d. Check for improperly seated valves. e. Check for incorrect injection timing. 	<ul style="list-style-type: none"> a. Adjust injectors (WP 0044 00). b. Replace defective fuel injector(s) (WP 0011 00). c. Repair fuel return line (TM 9-2320-283-20). d. Reseat or replace valves (WP 0014 00). e. Adjust injection system timing (WP 0042 00).
8. LOW OIL PRESSURE	<ul style="list-style-type: none"> a. Check pressure regulator b. Check for spun camshaft bushing. c. Inspect oil pump gasket. d. Check for worn camshaft. e. Check for worn crankshaft. f. Inspect main bearings. g. Inspect connecting rod bearings. h. Inspect oil pump gears. i. Check for high oil temperature. j. Check for worn crankshaft. 	<ul style="list-style-type: none"> a. Free up pressure regulator or replace oil pump (WP 0010 00). b. Replace camshaft bushing (WP 0013 00). c. Replace gasket (WP 0023 00). d. Replace camshaft (WP 0013 00). e. Replace crankshaft and install new bearings (WP 0012 00). f. Replace main bearings (WP 0012 00). g. Replace connecting rod bearings (WP 0012 00). h. Repair oil pump (WP 0023 00). i. Inspect and clean oil cooler (WP 0021 00). j. Repair crankshaft (WP 0016 00).

ENGINE TROUBLESHOOTING (Contd)*Table 1. Engine Troubleshooting (Contd).*

MALFUNCTION	TEST OR INSPECTION	CORRECTIVE ACTION
9. ENGINE KNOCKS	<ul style="list-style-type: none"> a. Check for broken piston. b. Check for broken injector cup. c. Check for incorrect valve adjustment. d. Check for incorrect injector adjustment. e. Check for loose connecting rod capscrews. f. Check for worn connecting rod bearings. g. Check for loose main bearing capscrews. h. Check for worn main bearings. i. Check for excessive crankshaft end clearance. j. Check for worn crankshaft. k. Check for worn piston pins. l. Check for broken piston. m. Check for incorrect injection timing. 	<ul style="list-style-type: none"> a. Replace piston (WP 0018 00). b. Repair injector (WP 0032 00). c. Adjust valves (WP 0043 00). d. Adjust injectors (WP 0043 00). e. Tighten connecting rod capscrews to proper torque and check bearings (WP 0042 00). f. Replace connecting rod bearings (WP 0012 00 and WP 0042 00). g. Torque main bearing capscrews (WP 0042 00). h. Replace main bearings (WP 0042 00). i. Check crankshaft end clearance (WP 0042 00). j. Replace crankshaft and install new bearings (WP 0042 00). k. Replace worn piston pins and bushings or replace rods (WP 0018 00). l. Replace piston (WP 0018 00). m. Adjust injector system timing (WP 0041 00).
10. EXCESSIVE FUEL CONSUMPTION	<ul style="list-style-type: none"> a. Check for incorrect valve and injector adjustment. b. Check for excessive fuel pressure. c. Check for restricted fuel drain. d. Check for defective injector(s). e. Check for leaking cylinder head gasket(s). f. Check for incorrect injection timing. 	<ul style="list-style-type: none"> a. Adjust valves and injectors (WP 0043 00). b. Test and calibrate fuel pump (WP 0044 00). c. Repair fuel crossover tubes (WP 0010 00). d. Replace defective injector(s) (WP 0011 00). e. Replace cylinder head gasket(s) (WP 0011 00). f. Adjust injector system timing (WP 0043 00).

ENGINE TROUBLESHOOTING (Contd)*Table 1. Engine Troubleshooting (Contd).*

MALFUNCTION	TEST OR INSPECTION	CORRECTIVE ACTION
11. EXCESSIVE OIL CONSUMPTION	<ul style="list-style-type: none"> a. Check for external leaks. b. Check turbocharger oil seals. c. Check for worn, stuck, or broken piston rings. d. Check for worn piston(s) and cylinder liner(s). e. Check for cracked piston. 	<ul style="list-style-type: none"> a. Tighten external oil connections and replace damaged gasket(s). b. Replace turbocharger oil seals (WP 0026 00 and WP 0027 00). c. Replace piston rings (WP 0018 00). d. Install new pistons and cylinder liners (WP 0012 00). e. Replace damaged piston (WP 0012 00).
12. EXCESSIVE ENGINE VIBRATION	<ul style="list-style-type: none"> a. Check for loose or worn engine insulators. b. Check for loose or worn cab insulators. c. Check for burned valves. d. Check for excessive flexdisk and ring gear runout. e. Check for loose flexdisk and ring gear mounting screws. f. Check for loose flywheel housing screws. g. Check for misalignment of flywheel housing. h. Check for unbalanced flexdisk and ring gear. i. Check for loose vibration damper. j. Check for unbalanced vibration damper. k. Check adjustment of valves and injectors. l. Check timing for air compressor. m. Check for incorrect injection timing. 	<ul style="list-style-type: none"> a. Replace mounts (TM 9-2320-283-34). b. Replace insulators (TM 9-2320-283-34). c. Replace valves (WP 0014 00). d. Correct flexdisk and ring gear runout (WP 0042 00). e. Tighten flexdisk and ring gear mounting screws (WP 0042 00). f. Tighten flywheel housing screws (WP 0042 00). g. Align flywheel housing (WP 0042 00). h. Replace the flexdisk and ring gear (WP 0013 00 and WP 0042 00). i. Tighten vibration damper screws (WP 0042 00). j. Install new vibration damper (WP 0042 00). k. Adjust valves and injectors (WP 0043 00). l. Adjust air compressor timing (WP 0042 00). m. Adjust injector system timing (WP 0042 00).

ENGINE TROUBLESHOOTING (Contd)*Table 1. Engine Troubleshooting (Contd).*

MALFUNCTION	TEST OR INSPECTION	CORRECTIVE ACTION
12. EXCESSIVE ENGINE VIBRATION (Contd)	<ul style="list-style-type: none"> n. Check for excessive flywheel runout. o. Check for unbalanced flywheel or one or more injectors not performing properly. 	<ul style="list-style-type: none"> n. Correct flywheel runout (WP 0042 00). o. Replace flywheel (WP 0042 00) or replace faulty injectors (WP 0043 00).
13. ENGINE WILL NOT IDLE	<ul style="list-style-type: none"> a. Check fuel pump idle setting. b. Check for improperly assembled governor spring. c. Check for stuck governor spring plunger. d. Check for plugged governor barrel. 	<ul style="list-style-type: none"> a. Adjust idle setting (WP 0044 00). b. Assemble governor spring correctly (WP 0037 00). c. Free governor spring plunger (WP 0037 00). d. Clean governor barrel (WP 0037 00).
14. FUEL LEAKS AT FUEL PUMP OR INJECTOR	<ul style="list-style-type: none"> a. Check for faulty seals and O-rings in fuel pump. b. Check for mutilated injector O-rings. c. Check for faulty fuel filter gasket. 	<ul style="list-style-type: none"> a. Install new seals and O-rings (WP 0033 00). b. Replace injector mounting O-rings (WP 0039 00). c. Replace gasket (WP 0039 00).
15. ENGINE DOES NOT DEVELOP FULL POWER	<ul style="list-style-type: none"> a. Check for damaged turbocharger. b. Check for improperly adjusted valves and injectors. c. Check for worn or scored fuel pump components. d. Check for dirty fuel injector(s). e. Check for scuffed cylinder liners. f. Check for incorrect injection timing. g. Check for plugged electric shutoff (solenoid) valve. h. Check for plugged fuel pump throttle control shaft. i. Check for burned valves. j. Check for plugged Air Fuel Control (AFC) breather (check valve). 	<ul style="list-style-type: none"> a. Repair turbocharger (WP 0026 00 and WP 0027 00). b. Adjust valves and injectors (WP 0043 00). c. Repair fuel pump (WP 0033 00). d. Clean fuel injector(s) (WP 0032 00). e. Replace cylinder liners (WP 0013 00). f. Adjust injection system timing (WP 0042 00). g. Clean electric shutoff valve (solenoid) (WP 0034 00). h. Clean or replace fuel pump throttle control shaft (WP 0040 00). i. Reface or replace valves and valve seats (WP 0014 00). j. Replace AFC breather (WP 0040 00).

ENGINE TROUBLESHOOTING (Contd)*Table 1. Engine Troubleshooting (Contd).*

MALFUNCTION	TEST OR INSPECTION	CORRECTIVE ACTION
16. ENGINE MISSES OR RUNS ERRATICALLY	<ul style="list-style-type: none"> a. Check for improperly adjusted valves and injectors. b. Check injector for leaking middle O-ring. c. Check for damaged rocker arms. d. Check for broken fuel injector plunger spring. e. Check for broken or deformed injector cup. f. Check for plugged injector cup spray holes. g. Check for plugged metering or drain orifice in fuel injectors. h. Check for burned or excessively pitted valves. i. Check for cracked or broken valve seat inserts. j. Check for incorrect injection timing. k. Check for leaking injector sleeves. 	<ul style="list-style-type: none"> a. Adjust valves and injectors (WP 0043 00). b. Replace injector middle O-ring (WP 0032 00). c. Replace rocker arms (WP 0020 00). d. Replace fuel injector plunger spring (WP 0032 00). e. Replace injector cup (WP 0032 00). f. Clean injector cups (WP 0032 00). g. Clean fuel injectors (WP 0032 00). h. Reface or replace valves and valve seat inserts (WP 0014 00). i. Replace damaged valve seat inserts (WP 0014 00). j. Adjust injection system timing (WP 0043 00). k. Replace injector sleeves (WP 0043 00).
17. EXCESSIVE GEAR NOISE	<ul style="list-style-type: none"> a. Check for broken or worn gear teeth. b. Check for excessive gear backlash. 	<ul style="list-style-type: none"> a. Replace gears or units having damaged teeth (refer to WP 0013 00, WP 0017 00 and WP 0036 00). b. Replace defective gears or shafts (refer to WP 0042 00).
18. EXCESSIVE OIL LOSS	<ul style="list-style-type: none"> a. Check for cracked or broken front gearcase cover. b. Check for defective seals and gaskets. c. Check for leaking rear cover oil seal or gaskets. 	<ul style="list-style-type: none"> a. Replace front gearcase cover (WP 0010 00 and WP 0045 00). b. Replace faulty seals and gaskets as required. c. Replace rear cover oil seal or gaskets (WP 0013 00).
19. SLUDGE FORMATION IN CRANKCASE	Check for moisture in crankcase.	<ul style="list-style-type: none"> a. Isolate the source and repair as required. b. Inspect for tears on head gasket cylinder openings.

ENGINE TROUBLESHOOTING (Contd)*Table 1. Engine Troubleshooting (Contd).*

MALFUNCTION	TEST OR INSPECTION	CORRECTIVE ACTION
20. LUBRICATING OIL DILUTED	<ul style="list-style-type: none"> a. Check for moisture in crankcase. b. Check injector for damaged O-ring. c. Check for defective injector(s). d. Check for broken piston. e. Check for cracked or broken piston rings. 	<ul style="list-style-type: none"> a. Isolate source and repair as required. b. Inspect for tears at head gasket cylinder openings. c. Replace injector O-ring (WP 0032 00). d. Repair injectors (WP 0032 00). e. Replace piston (WP 0018 00). f. Replace broken piston rings (WP 0018 00).
21. LOW COMPRESSION	<ul style="list-style-type: none"> a. Check adjustment of valve and injectors. b. Check for worn cylinder liners. c. Check for leaking cylinder head gasket. d. Check for worn piston rings. e. Check for incorrect timing. f. Check for valves not seating. 	<ul style="list-style-type: none"> a. Adjust valves and injectors (WP 0043 00). b. Replace cylinder liners (WP 0013 00). c. Replace gasket (WP 0011 00 and WP 0043 00). d. Replace piston rings (WP 0018 00). e. Adjust injection system timing (WP 0043 00). f. Reface valves and seats (WP 0014 00).
22. ENGINE OVERSPEED	<ul style="list-style-type: none"> a. Check for improperly adjusted governor. b. Check for defective governor or fuel pump. 	<ul style="list-style-type: none"> a. Adjust governor (WP 0038 00). b. Repair governor or fuel injection pump as necessary (WP 0033 00 and WP 0038 00).

CHAPTER 3

MAINTENANCE INSTRUCTIONS

FOR

ENGINE, DIESEL

CUMMINS MODEL NTC-400

M915, M915A1, M915A4,

M916, M920 VEHICLES

CHAPTER 3

MAINTENANCE INSTRUCTIONS

Work Package Title	Work Package/Page No.
Preventive Maintenance Checks and Services (PMCS) Introduction	WP 0005 00-1
Preventive Maintenance Checks and Services (PMCS) Instructions	WP 0006 00-1
Big Cam I Engine Removal	WP 0007 00-1
Big Cam III Engine Removal	WP 0008 00-1
Mounting Engine on Maintenance Stand	WP 0009 00-1
Engine Accessories Removal	WP 0010 00-1
Cylinder Head and Cylinder Head Components Removal . . .	WP 0011 00-1
Cylinder Block Components Removal	WP 0012 00-1
Cylinder Block	WP 0013 00-1
Cylinder Head	WP 0014 00-1
Vibration Damper and Crankshaft Pulley Cleaning and Inspection	WP 0015 00-1
Crankshaft Cleaning and Inspection	WP 0016 00-1
Flexplate, Flywheel, Flywheel Housing, and Rear Cover Cleaning and Inspection	WP 0017 00-1
Pistons, Connecting Rods, and Bearings	WP 0018 00-1
Camshaft, Camshaft Followers, and Pushrods	WP 0019 00-1
Rocker Levers and Rocker Lever Housing	WP 0020 00-1
Oil Cooler	WP 0021 00-1
Oil Pan, Dipstick, Oil Suction Tubes, and Breather Tube . . .	WP 0022 00-1
Oil Pump	WP 0023 00-1
Air Aftercooler	WP 0024 00-1
Exhaust Manifold	WP 0025 00-1
Turbocharger	WP 0026 00-1
Turbocharger HT-3B	WP 0027 00-1
Front Gear Cover	WP 0028 00-1
Accessory Drive and Accessory Drive Pulley	WP 0029 00-1
Engine Retarder	WP 0030 00-1
Air Compressor	WP 0031 00-1
Fuel Injector	WP 0032 00-1
Fuel Pump Disassembly	WP 0033 00-1
Solenoid Valve	WP 0034 00-1
Fuel Damper and Head	WP 0035 00-1
Fuel Gear Pump	WP 0036 00-1
Fuel Pump Governor Spring	WP 0037 00-1
Fuel Pump Front Cover and Governor	WP 0038 00-1

Work Package Title	Work Package/Page No.
Fuel Pump Main Housing	WP 0039 00-1
Fuel Pump Assembly	WP 0040 00-1
Water Pump	WP 0041 00-1
Cylinder Block Components Installation	WP 0042 00-1
Cylinder Head and Cylinder Head Components Installation	WP 0043 00-1
Fuel Pump Testing and Calibration	WP 0044 00-1
Engine Accessories Installation	WP 0045 00-1
Removing Engine from Maintenance Stand	WP 0046 00-1
Engine Testing	WP 0047 00-1
Big Cam III Engine Installation	WP 0048 00-1
Big Cam I Engine Installation	WP 0049 00-1
Big Cam III Modification Kit Installation Instructions	WP 0050 00-1
General Maintenance Instructions	WP 0051 00-1
Illustrated List of Manufactured Items	WP 0052 00-1
Torque Limits	WP 0053 00-1
Wear Limits	WP 0054 00-1

**DIRECT SUPPORT AND GENERAL SUPPORT
MAINTENANCE MANUAL
INCLUDING REPAIR PARTS AND SPECIAL TOOLS LIST (RPSTL)
FOR
M915, M915A1, M915A4, M916, M920 VEHICLES**

NSN 2815-01-082-8125	P/N NTC400-3652-02	CUMMINS NTC-400 BIG CAM I DIESEL ENGINE W/CONTAINER
NSN 2815-01-142-2745	P/N 11669835	CUMMINS NTC-400 BIG CAM III DIESEL ENGINE W/CONTAINER

PREVENTIVE MAINTENANCE CHECKS AND SERVICES (PMCS) INTRODUCTION

SCOPE

This Work Package (WP) explains the content and format of the Unit Level PMCS Instructions table contained in WP 0006 00. Also included in this WP are PMCS and lubrication guidelines that should be reviewed before performing any PMCS procedures.

EXPLANATION OF PMCS TABLE

Item Number Column. Numbers in this column are for reference. When completing DA Form 2404 (Equipment Inspection and Maintenance Worksheet), include the item number for the check/service indicating a fault. Item numbers also indicate the order in which you must perform checks and services for the interval listed.

Interval Column. This column tells you when you must perform each procedure in each Procedure column.

Before—procedures must be done immediately before you operate the vehicle.

During—procedures must be done while you are operating the vehicle.

After—procedures must be done immediately after you have operated the vehicle.

Weekly—procedures must be done once each week.

Monthly—procedures must be done once each month.

Item to Inspect/Service Column. This column provides the location and item to be checked or serviced and manhours to complete task.

Procedure Column. This column identifies the procedure you must perform to check or service the item listed in the Item to Inspect/Service column. You must perform the procedure at the time stated in the interval column.

Equipment Not Ready/Available If: Column. Information in this column tells you what faults keep your equipment from being capable of performing its primary mission. If checks or service procedures show faults listed in this column, the equipment is not mission-capable. Follow standard operating procedures for maintaining the equipment or reporting equipment failure.

PREVENTIVE MAINTENANCE CHECKS AND SERVICES (PMCS) INTRODUCTION (Contd)

PMCS GUIDELINES

Before performing preventive maintenance, read all the checks required for the applicable interval and prepare all the tools you need to make all the checks.

Always perform PMCS in the same order so it becomes a habit. Once you've had some practice, you should be able to spot problems in a hurry. If the vehicle does not perform as required, refer to the appropriate troubleshooting procedure in WP 0004 00.

If anything looks wrong and you can't fix it, write it on your DA Form 2404. If you find something seriously wrong, IMMEDIATELY report it to your supervisor.

Keep It Clean. Dirt, grease, oil, and debris get in the way and may cover up a serious problem. Clean as you work and as needed. Use detergent (Item 34, WP 0060 00) and water when you clean metal, rubber, plastic, and painted surfaces.

Rust and Corrosion. Inspect metal parts for rust and corrosion. If any bare metal or corrosion exists, clean and apply a light coat of lubricating oil (Item 16, WP 0060 00) and report it to your supervisor.

Bolts, Nuts, and Screws. Inspect bolts, nuts, and screws for obvious looseness and missing, bent, or broken condition. Inspect for chipped paint, bare metal, or rust around bolt heads. If you find one you think is loose, tighten it.

Welds. Inspect for loose or chipped paint, rust, or gaps where parts are welded together. If you find a bad weld, report it to your supervisor.

Electric Wires and Connectors. Inspect for cracked, chafed, or broken insulation, bare wires, and loose or broken connectors. Tighten loose connectors and ensure that the wires are in good condition.

Hoses and Fluid Lines. Inspect for wear, damage, and signs of leaks. Ensure that clamps and fittings are tight. Wet spots indicate leaks, but a stain around a fitting or connector can also mean a leak. If a leak comes from a loose fitting or connector, tighten it. If something is broken or worn out, report it to your supervisor.

Fluid Leakage. It is necessary for you to know how fluid leakage affects the status of the engine. Following are types/classes of leakage you need to know to be able to determine the status of your truck. Learn these leakage definitions and remember: when in doubt, notify your supervisor.

CAUTION

- Equipment operation is allowed with minor leakages (Class I or II). Consideration must be given to fluid capacity in the item/system being checked/inspected. When in doubt, notify your supervisor.
- When operating with Class I or II leaks, continue to check fluid levels as required in the PMCS.
- Class III leaks should be reported immediately to your supervisor.

Leakage Definitions for PMCS

- Class I Seepage of fluid (as indicated by wetness or discoloration) not great enough to form drops.
- Class II Leakage of fluid great enough to form drops, but not enough to cause drops to drip from item being checked/inspected.
- Class III Leakage of fluid great enough to form drops that fall from item being checked/inspected.

PREVENTIVE MAINTENANCE CHECKS AND SERVICES (PMCS) INTRODUCTION (Contd)

LUBRICATION GUIDELINES

1. These instructions are mandatory.
2. This equipment is enrolled in the Army Oil Analysis Program (AOAP). Engine oil and transmission oil must be sampled every 90 days as prescribed by DA PAM 738-750.
3. Engines must receive lubrication with approved lubricants at recommended intervals in order to be mission-ready at all times.
4. Recommended intervals are based on normal conditions of operation, temperature, and humidity. When operating under extreme conditions, lubricants should be changed more frequently. When in doubt, notify your supervisor.

SPECIFIC LUBRICATION INSTRUCTIONS

1. Keep all lubricants in a closed container and store in a clean, dry place away from extreme heat. Keep container covers clean and do not allow dust, dirt, or other foreign material to mix with lubricants. Keep lubrication equipment clean and ready for use.
2. Maintain a record of lubrication performed and report any problems noted during lubrication. Refer to DA PAM 738-750 for maintenance forms and procedures to record and report any findings.
3. Keep all external parts of equipment not requiring lubrication free of lubricants. After lubrication, wipe off excess lubricant to prevent accumulation of foreign matter.
4. Refer to FM 9-207 for lubrication instructions in cold weather.

**DIRECT SUPPORT AND GENERAL SUPPORT
MAINTENANCE MANUAL
INCLUDING REPAIR PARTS AND SPECIAL TOOLS LIST (RPSTL)
FOR
M915, M915A1, M915A4, M916, M920 VEHICLES**

NSN 2815-01-082-8125	P/N NTC400-3652-02	CUMMINS NTC-400 BIG CAM I DIESEL ENGINE W/CONTAINER
NSN 2815-01-142-2745	P/N 11669835	CUMMINS NTC-400 BIG CAM III DIESEL ENGINE W/CONTAINER

PREVENTIVE MAINTENANCE CHECKS AND SERVICES (PMCS) INSTRUCTIONS

INTERVALS

An overhauled engine must receive periodic maintenance to ensure it remains reliable and meets its expected service life. To meet these in-service expectations, PMCS service items and intervals included in this in this Work Package (WP) are to be followed.

These instruction apply only to vehicles in normal operation. Engines must be serviced more frequently to compensate for abnormal or extreme conditions, such as high or low temperatures, immersions in water, or exposure to sand or dust. Intervals for changing filters (fuel, oil, air, etc.) are the same. Lubricants that have become contaminated must be changed regardless of scheduled intervals. Intervals for items under warranty must follow manufacturer recommendations until after the warranty has expired.

Points requiring lubrication at 1000 or 2000 miles on vehicles not accumulating that amount in a six-month period will be lubricated semi-annually. Points requiring lubrication at 10,000, 24,000, or 50,000 miles on vehicles not accumulating that amount in a twelve-month period will be lubricated annually. When practicable, lubrication services will coincide with vehicle organizational PMCS.

PREVENTIVE MAINTENANCE CHECKS AND SERVICES (PMCS) INSTRUCTIONS (Contd)

FUEL PUMP SCREEN AND FUEL FILTER

WARNING

Compressed air used for cleaning purposes must not exceed 30 psi. Use only with effective chip guarding and personal protective equipment (goggles/shield, gloves, etc.).

Fuel Pump Screen—Soak screen in a carbon dissolving agent, then flush it in a sonic cleaner unit, or clean screen in fuel oil and dry with compressed air. Visually inspect screen for holes or embedded metal particles in mesh. Discard screen if damaged or worn and replace with new part.

Fuel Filter (spin-on type)—Change fuel filter at 10,000-mile intervals. Open petcock and drain fuel into a suitable container. Remove element with a filter wrench and transfer petcock from old filter to new.

CRANKCASE

Check oil level daily and change oil hot full flow bypass filter elements at 10,000 miles or six months, whichever ever occurs first. To check engine oil level, wait at least 1 minute after stopping to allow oil to drain into crankcase. Safe operating level is between ADD and FULL mark on dipstick. Engine capacity is 11.5 gallons with both filters. Check and clean crankcase breather and attaching hoses whenever oil is changed.

STARTER

NOTE

Do not lubricate alternator and starter wiring.

Remove starter every 100,000 miles for lubrication. Refer to TM 9-2320-273-20. Remove three socket head screws, add three to five drops of SAE oil to each reservoir, and lubricate drive and drive spline. Clean with solvent, then apply a thin coat of grease (GAA) so the pinion will move freely.

ALTERNATOR

Inspect alternator at 100,000-mile intervals. No lubrication is required. Bearings are sealed for life.

AIR FILTER

WARNING

Compressed air used for cleaning purposes must not exceed 30 psi. Use only with effective chip guarding and personal protective equipment (goggles/shield, gloves, etc.).

Service air filter when red shows in window of restriction indicator or at 2000 miles, whichever ever comes first. Refer to TM 9-2320-273-10 for location and function of indicator. Outside element can be washed up to five times or blown clean with air an indefinite number of times. Outside element is costly and should be reused. Handle and clean carefully. Inside safety filter should not be washed or blown clean and should be replaced every 10,000 miles.

Clean the outside element by tapping the element, reverse flow cleaning with compressed air, or washing in water with a mild non-sudsing detergent.

TEMPERATURE RISE

If ambient temperature rises to +70° F for no more than one week, use of OE/HDO 10 lubricating oil is permissible. If ambient temperature rises to +32° F for no more than one week, use of OEA lubricating oil is permissible.

PREVENTIVE MAINTENANCE CHECKS AND SERVICES (PMCS) INSTRUCTIONS (Contd)

UNIT LEVEL PMCS

Table 1. Unit Level PMCS Instructions.

ITEM NO.	INTERVAL	MAN HOURS	ITEM TO CHECK/SERVICE	PROCEDURE	EQUIPMENT NOT READY/ AVAILABLE IF:
1	Semi-annual	0.5	Pre-service	a. Notice if starter engages smoothly and turns engine at normal cranking speed. b. Listen for unusual engine noise at idle, at operating speeds, and under acceleration. Be alert for excessive vibration and the smell of oil, fuel, and exhaust. c. Check engine operation at all speeds. Ensure that engine does not go above, or below, engine governed speed (600–2100 rpm)	a. Starter inoperative or makes excessive grinding noise. b. Engine knocks, rattles, or smokes excessively. c. Engine governed speed at no-load is below 600 rpm or exceeds 2100 rpm.
2	Semi-annual	2.0	Fuel system	a. Inspect fuel filter/water separator assembly for dents and cracks that could cause leaks. b. Replace filter element every 3,000 miles (4,827 km) or semiannually, whichever occurs first. <p style="text-align: center;">WARNING</p> Adhesives, solvents, and sealing compounds can burn easily, give off harmful vapors, and damage skin and clothing. To avoid injury or death, keep away from fire and use in well-ventilated area. If adhesive, solvents, or sealing compound get on skin or clothing, wash immediately with soap and water. c. Clean screen by soaking in a carbon dissolving agent, then flush in a sonic cleaner unit, or clean screen in fuel oil and dry with compressed air. Visually inspect screen for holes or embedded metal particles in mesh.	a. Any Class III leak. b. Fuel filter clogged. c. Screen is worn or damaged.

PREVENTIVE MAINTENANCE CHECKS AND SERVICES (PMCS) INSTRUCTIONS (Contd)

Table 1. Unit Level PMCS Instructions (Contd).

ITEM NO.	INTERVAL	MAN HOURS	ITEM TO CHECK/SERVICE	PROCEDURE	EQUIPMENT NOT READY/ AVAILABLE IF:
2 (Contd)		4.8		<p>d. Purge and clean fuel tank (TB 43-0212), if required.</p> <p>e. Inspect fuel injection pump, nozzle lines, and fittings for leaks and damage.</p> <p>f. Inspect all fuel lines for loose connections, splits, cracks, and kinks that could leak.</p>	<p>e. Rubber cap missing or torn on return line.</p> <p>f. Any Class III leak.</p>
3	Semi-annual	2.0	Aftercooler	Inspect aftercooler for leaks and loose hardware.	Class III leaks or loose hardware.
4	Semi-annual	0.5	Engine accessory drive	Inspect for missing, broken, cracked, and frayed drivebelts; dry rot; excessive fraying; and cracks.	Any drivebelt is missing or broken; belt fiber has more than one crack (50% of belt thickness) or has frays more than 2 in. (5.08 cm) long.
5	Semi-annual	0.5	Water pump	<p>a. Inspect pulley for alignment.</p> <p>b. Inspect belt for proper tension (1/2–3/4 in. (1.2–1.9 cm)) deflection when you press down firmly.</p> <p>c. Inspect water pump for leaks and inspect fan shrouds for secure mounting.</p>	b. Any drivebelt is missing or broken; belt fiber has more than one crack (50% of belt thickness) or has frays more than 2 in. (5.08 cm) long.
6	Semi-annual	0.5	Thermostat housing and front, center, and rear water manifolds	Inspect thermostat housing and water manifold for leaks.	
7	Semi-annual	0.5	Alternator wiring and engine mount	<p>a. Inspect for loose wiring connections or worn insulation.</p> <p>b. Inspect for cracked or loose engine mounts.</p>	<p>a. Loose connections or worn insulation.</p> <p>b. Cracked or loose engine mounts.</p>

PREVENTIVE MAINTENANCE CHECKS AND SERVICES (PMCS) INSTRUCTIONS (Contd)

Table 1. Unit Level PMCS Instructions (Contd).

ITEM NO.	INTERVAL	MAN HOURS	ITEM TO CHECK/SERVICE	PROCEDURE	EQUIPMENT NOT READY/ AVAILABLE IF:
8	Semi-annual	1.0	Cooling system	<p style="text-align: center;"><u>WARNING</u></p> <p>If vehicle has been operating, use extreme care to avoid being burned when removing cooling system radiator cap. Use heavy rags or gloves to protect hands. Turn radiator cap only one-half turn counterclockwise and allow pressure to be relieved before fully removing cap.</p> <p style="text-align: center;">NOTE</p> <p>Coolant level is correct when sight glass is full (TM 9-2320-273-10). Use MIL-A-46153 in temperatures above 0° F (-18° C).</p> <p>a. Inspect coolant condition. Test coolant to see if draining is required (TB 750-651).</p> <p>b. Inspect all hoses for looseness, splits, wear, and cracks that would cause leaks.</p> <p>c. Inspect hose clamps for wear and serviceability.</p>	<p>a. Coolant condition/testing shows draining is required.</p> <p>b. Class III leakage evident. Hoses are loose or have splits or cracks.</p> <p>c. Hose clamps are worn or unserviceable.</p>
9	Semi-annual		Engine crankcase	<p style="text-align: center;">NOTE</p> <p>For operation of equipment in expected continuous temperatures below 0° F (-18° C), remove lubricants prescribed for temperatures above 0° F (-18° C). Relubricate with lubrication specified for temperatures 0° F to -50° F (-18° C to -460° C).</p> <p style="text-align: center;">NOTE</p> <p>If AOAP laboratory is not available, drain and refill engine crankcase with OE/HDO every 6,000 miles (9,654 km) or semiannually, whichever comes first. Lubricate fan clutch with GAA.</p>	<p>“Do not operate” received from AOAP lab.</p>

PREVENTIVE MAINTENANCE CHECKS AND SERVICES (PMCS) INSTRUCTIONS (Contd)

Table 1. Unit Level PMCS Instructions (Contd).

ITEM NO.	INTERVAL	MAN HOURS	ITEM TO CHECK/SERVICE	PROCEDURE	EQUIPMENT NOT READY/ AVAILABLE IF:
10	Semi-annual	1.0	Engine crankcase	a. Drain and refill crankcase with OE/HDO lubricating oil. b. Replace engine oil filter and bypass oil filter. c. Inspect all oil lines and hoses for cracks and wear that could cause leaks. d. Inspect oil filter housing and oil pan drain plug for looseness. Ensure oil pan bolts are tight.	b. Oil filter has Class III leak. c. Cracks, frays, leaks, and wear are evident. d. Drain plugs and oil pan bolts are loose.
11	Semi-annual	0.4	Rocker cover gaskets	Inspect rocker cover gasket for oil leaks. If necessary, tighten bolts and/or replace gaskets.	Crack, frays, leaks, and wear are evident.
12	Semi-annual	0.5	Oil cooler and lines	Inspect oil cooler for leaks, loose hardware, and damaged fittings.	Crack, frays, leaks, and wear are evident.

PREVENTIVE MAINTENANCE CHECKS AND SERVICES (PMCS) INSTRUCTIONS (Contd)

MAINTENANCE ALLOCATION CHART

The Maintenance Allocation Charts (MACs), tables 2 and 3, designate overall authority and responsibility for the performance of maintenance functions on the identified end item or component. The application of the maintenance functions to the end item or component will be consistent with the capacities and capabilities of the designated maintenance categories.

EXPLANATION OF MAINTENANCE ALLOCATION CHART

Column 1, Group Number—Column 1 lists code numbers, which identify maintenance significant components, assemblies, subassemblies, and modules with the higher assembly.

Column 2, Component/Assembly—Column 2 contains the names of components, assemblies, subassemblies, and modules for which maintenance is authorized.

Column 3, Maintenance Function—Column 3 lists the functions to be performed on the item listed in Column 2.

Column 4, Maintenance Category—Column 4 specifies the category of maintenance authorized to perform each maintenance function at the indicated category of maintenance. If the number or complexity of the tasks within the listed maintenance function varies at different maintenance categories, appropriate “work time” figures will be shown for each category. The “work time” figure represents the average time required to restore an item (assembly, subassembly, component, module, end item, or system) to a serviceable condition under typical field operating conditions. This time includes preparation time (including any necessary disassembly/assembly time), troubleshooting/fault location time, and quality assurance/quality control time in addition to the time required to perform each specific task. The symbol designations for the various maintenance categories are as follows:

- F Direct Support Maintenance
- H General Support Maintenance

Column 5, Tools and Equipment—Column 5 specifies, by code, those common tool sets (not individual tools) and special tools, TMDE, and support equipment required to perform the designated function.

PREVENTIVE MAINTENANCE CHECKS AND SERVICES (PMCS) INSTRUCTIONS (Contd)

Table 2. Maintenance Allocation Chart for M915–M920.

(1) GROUP NO.	(2) COMPONENT/ ASSEMBLY	(3) MAINTENANCE FUNCTION	(4) MAINTENANCE CATEGORY		(5) TOOLS AND EQUIPMENT
			F	H	
01	ENGINE	Repair Adjust Test	19.2 3.8 0.4		2-3-4
0100	Engine (Diesel)	Service Replace Repair	11.0	65.0	1 thru 77, 81, 84, 85, 97
	Engine Mount	Inspect Replace	0.4		99 thru 180, 189 thru 221
0101	Cylinder Head	Inspect Replace Repair	1.0 7.0 10.4		2 thru 44, 50
	Engine Block	Inspect Repair		2.0 40.0	8 99 thru 116 128, 129
	Cylinder and Sleeve Assembly	Inspect Replace	0.5	18.0	99 thru 101 128
0102	Crankshaft and Main Bearings	Inspect Replace		0.5 17.3	117 thru 119
	Main Seals	Inspect Replace	0.1 20.0		120 thru 127 194, 195
	Vibration Damper	Inspect Replace	0.5 1.0		
0103	Flywheel Assembly	Replace	13.0		45
0104	Connecting Rods, Bearings and Pistons Assembly	Inspect Replace Repair		0.3 27.0 8.0	207 thru 215 221

PREVENTIVE MAINTENANCE CHECKS AND SERVICES (PMCS) INSTRUCTIONS (Contd)

Table 2. Maintenance Allocation Chart for M915-M920 (Contd).

(1) GROUP NO.	(2) COMPONENT/ ASSEMBLY	(3) MAINTENANCE FUNCTION	(4) MAINTENANCE CATEGORY		(5) TOOLS AND EQUIPMENT
			F	H	
0105	Valves	Inspect Adjust Replace	0.8 1.8 14.0		71 thru 77 2
	Chamshaft and Bearing	Inspect Adjust Replace		27.0	197 thru 206
	Cam Follower Housing	Inspect Replace		0.2 12.0	46 thru 49 51 thru 54, 81
	Cam Follower	Inspect Replace		0.2 14.0	
	Push Tubes (Valve)	Inspect Replace		0.1 8.0	
	Timing Gear	Inspect Replace		0.6 24.0	
	Rocker Arm Assembly	Inspect Replace	0.6 2.5		
	Valve Cover and Gasket	Inspect Replace			

PREVENTIVE MAINTENANCE CHECKS AND SERVICES (PMCS) INSTRUCTIONS (Contd)

Table 2. Maintenance Allocation Chart for M915-M920 (Contd).

(1) GROUP NO.	(2) COMPONENT/ ASSEMBLY	(3) MAINTENANCE FUNCTION	(4) MAINTENANCE CATEGORY		(5) TOOLS AND EQUIPMENT	
			F	H		
0106	Oil Pump	Inspect Replace Repair	1.5 2.5	65.0	130 thru 132	
	Oil Filter	Service Replace	10.8		143	
	Oil Filter Adapter	Replace				
	Bypass Oil Filter					
	Oil Pan	Service Replace				
	External Lines		Inspect Replace	2.0		
			Repair	1.3		
	Oil Breather	Inspect Replace				
	Oil Cooler	Inspect Service Replace				
	Oil Pressure Regulator	Inspect Replace	3.0		55	
Level Gauge (dipstick)		Inspect Test	0.1 0.8			
		Replace	0.2			
		Replace				
0108	Aftercooler	Inspect Repair Replace	2.0 2.5			
	Exhaust Manifold	Inspect Replace	2.8			
109	Accessory Drive	Inspect Repair Replace	0.5 2.0 4.5		56 thru 65	
0112	Engine Retarder	Inspect		6.0	81	
		Repair	3.0			
		Replace Adjust	1.5			

PREVENTIVE MAINTENANCE CHECKS AND SERVICES (PMCS) INSTRUCTIONS (Contd)

Table 2. Maintenance Allocation Chart for M915–M920 (Contd).

(1) GROUP NO.	(2) COMPONENT/ ASSEMBLY	(3) MAINTENANCE FUNCTION	(4) MAINTENANCE CATEGORY		(5) TOOLS AND EQUIPMENT
			F	H	
03	FUEL SYSTEM				
0301	Fuel Injector Assembly	Test Adjust Replace Calibrate Repair	0.8 4.0 4.0	1.0 1.8	71 thru 77, 84 3 thru 12-84 152
0302	Fuel Pump Assembly Service of Filter and Screw Engine Fuel Lines and Fittings	Inspect Service Test Replace Calibrate Repair Inspect Replace	4.8 2.0	3.5 8.9	159 160 166 thru 171 174 192 155, 156, 158 161 thru 164 165, 172, 173 177 thru 179 189 thru 191, 193, 216 thru 220

PREVENTIVE MAINTENANCE CHECKS AND SERVICES (PMCS) INSTRUCTIONS (Contd)

Table 3. Maintenance Allocation Chart for M915A1.

(1) GROUP NO.	(2) COMPONENT/ ASSEMBLY	(3) MAINTENANCE FUNCTION	(4) MAINTENANCE CATEGORY		(5) TOOLS AND EQUIPMENT
			F	H	
01	ENGINE				
0100	Engine (Diesel)	Service Replace Repair	16.0	65.0	83 143
	Engine Mount	Inspect Replace	0.4		
0101	Cylinder Head	Inspect Replace Repair	1.0 7.0 10.4	2.0 10.0	84, 86, 87, 88, 90, 91, 95 thru 95 103, 104, 109, 110, 112, 114, 121 thru 124, 126, 141, 168
	Engine Block	Inspect Repair			144, 145, 158, 170, 171
	Cylinder and Sleeve Assembly	Inspect Replace	0.5	18.0	166
0102	Crankshaft and Main Bearings	Inspect Replace		0.5 17.3	143
	Main Seals	Inspect Replace	0.1 20.0		100, 172
	Vibration Damper	Inspect Replace	0.5 1.0		
0103	Disk & Gear Assembly	Replace	13.0		
0104	Connecting Rods, Bearings and Pistons Assembly	Inspect Replace Repair		0.3 7.0 8.0	135,138, 161,154, 133,134,147

PREVENTIVE MAINTENANCE CHECKS AND SERVICES (PMCS) INSTRUCTIONS (Contd)

Table 3. Maintenance Allocation Chart for M915A1 (Contd).

(1) GROUP NO.	(2) COMPONENT/ ASSEMBLY	(3) MAINTENANCE FUNCTION	(4) MAINTENANCE CATEGORY		(5) TOOLS AND EQUIPMENT
			F	H	
0105	Valves	Inspect Adjust Replace	0.8 1.8 14.0		71 thru 77 2
	Chamshaft and Bearing	Inspect Replace		0.8 27.0	197 thru 206
	Cam Follower Housing	Inspect Replace		0.2 12.0	46 thru 49 51 thru 54, 81
	Cam Follower	Inspect Replace		0.2 14.0	
	Push Tubes (Valve)	Inspect Replace		0.1 8.0	
	Timing Gear	Inspect Replace		0.6 24.0	106, 113, 117
	Rocker Arm Assembly	Inspect Replace	0.6 2.5		93
	Valve Cover and Gasket	Inspect Replace			

PREVENTIVE MAINTENANCE CHECKS AND SERVICES (PMCS) INSTRUCTIONS (Contd)

Table 3. Maintenance Allocation Chart for M915A1 (Contd).

(1) GROUP NO.	(2) COMPONENT/ ASSEMBLY	(3) MAINTENANCE FUNCTION	(4) MAINTENANCE CATEGORY		(5) TOOLS AND EQUIPMENT		
			F	H			
0106	Oil Pump	Inspect Replace Repair	1.5 2.5	3.0	142.165		
	Oil Filter	Service Replace					
	Oil Filter Adapter	Replace					
	Oil Pan	Inspect Replace Repair	2.0 1.3	2.0			
	External Lines	Inspect Replace					
	Oil Breather	Inspect Service Replace					
	Oil Cooler	Inspect Replace Repair	3.0				
	Oil Pressure Regulator	Inspect Test Replace	0.1 0.8 0.2				
	Level Gauge (dipstick)	Replace					
	0108	Aftercooler	Inspect Repair Replace			2.0 2.5	
Exhaust Manifold		Inspect Replace	2.8				
0109	Accessory Drive	Inspect	0.5				111, 129 129
		Repair	2.0				
		Replace	4.5				
0112	Engine Retarder	Inspect		6.0	121, 130		
		Repair	3.0				
		Replace Adjust	1.5				
0121	Engine	Repair	4.0		117 34, 43, 40, 94, 101		
		Replace	2.0				

PREVENTIVE MAINTENANCE CHECKS AND SERVICES (PMCS) INSTRUCTIONS (Contd)**TOOL AND TEST EQUIPMENT REQUIREMENTS**

Column 1—Reference Code. The tool and test equipment reference code correlates with a code used in tables 2 and 3, Column 5.

Column 2—Maintenance Category. The lowest category of maintenance authorized to use the tool or test equipment.

Column 3—Nomenclature. Name or identification of the tool or test equipment.

Column 4—National Stock Number. The national stock number of the tool or test equipment.

Column 5—Tool Number. The manufacturer's part number.

PREVENTIVE MAINTENANCE CHECKS AND SERVICES (PMCS) INSTRUCTIONS (Contd)

Table 4. Tool and Test Equipment Requirements for M915-M920.

REF CODE	MAINTENANCE CATEGORY	NOMENCLATURE	NATIONAL STOCK NO.	TOOL NUMBER
1	F H	Checking Tool, Blow-By		3375150
2	F H	Reamer, Valve Guide	5110-00-980-7347	ST-646
3	F H	Cutting Tool, Bead	5110-00-932-2089	ST-788
4	F H	Expander, Tube, Roller	3441-00-922-6699	ST-880
5	F H	Cage		ST-880-1
6	F H	Roll		ST-880-2
7	F H	Nut, Thrust		ST-880-6
8	F H	Mandrel		ST-880-7
9	F H	Cutter, Injector Sleeve	4910-00-981-3105	ST-884
10	F H	Holder		ST-884-1
11	F H	Cutter		ST-884-3
12	F H	Pilot		ST-884-6
13	F H	Tool, Cylinder Head	4910-00-999-1499	ST-913
14	F H	Lockscrew		ST-913-1
15	F H	Bearing		ST-913-7
16	F H	Plug, Locking		ST-913-11
17	F H	Insert, Fiber		ST-913-18
18	F H	Screw Assembly, Adjusting		ST-913-23
19	F H	Tool Holder		ST-913-14
20	F H	Tool Bit		ST-913-17
21	F H	Tool, Grooving	5120-00-178-0948	ST-1100
22	F H	Body (5-1/2 In. Bore)		ST-1100-10
23	F H	Nut, Adjusting (1-1/4-20 Thread)		ST-1100-7
24	F H	Capscrew (1/4-28 x 3/16 In.)		ST-1100-6
25	F H	Sleeve, Rod		ST-1100-8
26	F H	Rod, Tool Adjusting		ST-1100-11
27	F H	Spring, Rod		ST-1100-9
28	F H	Cap, Tool Setting		ST-1100-14
29	F H	Cutting Tool		ST-1100-13
30	F H	Spring, Tool		ST-1100-12
31	F H	Sleeve Injector	4910-00-150-5858	ST-1140
32	F H	Holding Tool, Injector Sleeve	5120-00-104-1795	ST-1179
33	F H	Driver, Injector Sleeve	5120-00-981-3108	ST-1227
34	F H	Puller, Injector Sleeve	5120-00-113-5271	ST-1244
35	F H	Tip, Extractor		ST-1244-7
36	F H	Rod		ST-1244-2

PREVENTIVE MAINTENANCE CHECKS AND SERVICES (PMCS) INSTRUCTIONS (Contd)

Table 4. Tool and Test Equipment Requirements for M915-M920 (Contd).

REF CODE	MAINTENANCE CATEGORY	NOMENCLATURE	NATIONAL STOCK NO.	TOOL NUMBER
37	F H	Collar, Forming		ST-1244
38	F H	Spacer		ST-1244
39	F H	Bridge, Support		ST-1244
40	F H	Washer, Thrust		ST-1244-5
41	F H	Nut (1-8 Thread)		ST-1244
42	F H	Nut (9/16-12 Thread)		ST-1244
43	F H	Driver		ST-1244
44	F H	Driver, Valve Guide		3375282
45	F H	Attachment, Dial Gauge		ST-1325
46	F H	Bushing, Block and Mandrel, Lever	5180-00-916-1813	ST-249
47	F H	Mandrel		ST-249-1
48	F H	Mandrel		ST-249-2
49	F H	Sleeve		ST-249-3
50	F H	Spacer, Crosshead Guide	4910-00-150-3797	ST-633
51	F H	Mandrel Set, Machine	3460-00-499-1210	ST-691
52	F H	Mandrel		ST-691-1
53	F H	Block		ST-691-2
54	F H	Mandrel		ST-691-3
55	F H	Mandrel, O-Ring, Lubricating Oil Cooler		ST-1218
56	F H	Pulley Assembly, Tool	5180-00-944-0374	ST-386
57	F H	Arbor		ST-386-2
58	F H	Nut		ST-386-3
59	F H	Adapter, Ball, Thrust Bearing		ST-386-11
60	F H	Spacer		ST-386-5
61	F H	Adapter		3375205
62	F H	Adapter (2-1/4 In. x 7/8 In. Dia.)		ST-386-10
63	F H	Adapter (2-1/4 In. x 1 In. Dia.)		ST-386-9
64	F H	Adapter (2-1/4 In. x 1 In. Dia.)		ST-386-8
65	F H	Adapter (1-7/8 In. x 1 In. Dia.)		ST-386-6
66	F H	Mandrel, Water Pump Seal		ST-658
67	F H	Mandrel, Water Pump Seal	5120-00-159-8916	ST-659
68	F H	Fixture, Bearing Disassembly		ST-1114
69	F H	Water Pump Seal Driver		ST-1159
70	F H	Driver, Water Pump Drive Shaft Oil Seal		3375180
71	F H	Adapter, Torque Wrench	5120-00-103-4687	ST-669
72	F H	Driver, 3/8 In., Plastic Handle		F-40A

PREVENTIVE MAINTENANCE CHECKS AND SERVICES (PMCS) INSTRUCTIONS (Contd)

Table 4. Tool and Test Equipment Requirements for M915-M920 (Contd).

REF CODE	MAINTENANCE CATEGORY	NOMENCLATURE	NATIONAL STOCK NO.	TOOL NUMBER
73	F H	Handle		ST-699-1
74	F H	Blade, Screwdriver 1/2 In. x 0.062 In.		M-1302 A-5
75	F H	Blade, Screwdriver 1/4 In. x 0.032 In.		TM-82
76	F H	Socket, 3/4 In. Deep Double Hex		M-1302B-24
77	F H	Socket, 9/16 In. Deep Double Hex		M-1302B-18
78	F H	Rod, Expanding		CG-40-4
79	F H	Collet 43/64 to 52/64		CG-40-11
80	F H	Socket 1/4 In. 12 Point, 1/4 In. Drive		STMD-8
81	F H	Socket, Jacobs Brake		B1465A
82	O F H	Installing Tool, Seal		RD259A
83	O F H	Handle, Seal Installing Tool		RD263
84	F H	Fixture, Injector Timing	4910-00-712-0537	ST-593
85	F H	Wrench, Air Compressor	5120-01-072-2952	3375159
86	F H	Bar, Bearing Puller		11074
87	F H	Yoke Installer		J-26422-10
88	F H	Wrench, Differential Adjusting Nut		J-972
89	F H	Tool, Remove-Replace Windshield Moulding	5120-00-279-8422	CPR109701
90	F H	Tool, Yoke Installer	4120-01-014-0017	J-26422
91	F H	Shaft, 1-1/4-12 Thread		J-26422-2
92	F H	Nut		J-26422-3
93	F H	Shaft 1-1/4-12		J-26422-4
94	F H	Sleeve		J-26422-1
95	F H	Wear Sleeve Installation Tool		J-26424
96	O F H	Socket, Pusher Axle 3-3/16 In.		J-7757-2
97	O F H	Thermostat Seal Mandrel		ST-1225
98	O F H	Socket, Wheel Bearing		1902
99	H	Tool, Counterbore	5120-00-150-7488	ST-1295
100	H	Holder, Tool	5120-00-150-7489	ST-1065
101	H	Tool Bit, Counterbore		ST-1059-17
102	H	Boring Tool, Liner Counterbore		ST-1168
103	H	Bearing, Drive		ST-1168-4
104	H	Screw, Drive		ST-1168-6
105	H	Shaft, Drive		ST-1168-3
106	H	Sprocket, Drive		ST-1168-5
107	H	Chain, Drive		ST-1168-7
108	H	Sprocket, Drive		ST-1168-10
109	H	Tool Bit		ST-1168-19
110	H	Ring, Snap, Drive Shaft		ST-1168-8

PREVENTIVE MAINTENANCE CHECKS AND SERVICES (PMCS) INSTRUCTIONS (Contd)

Table 4. Tool and Test Equipment Requirements for M915-M920 (Contd).

REF CODE	MAINTENANCE CATEGORY	NOMENCLATURE	NATIONAL STOCK NO.	TOOL NUMBER
111	H	Ring, Snap, Drive Bearing		ST-1168-9
112	H	Counterbore Tool Liner		ST-1255
113	H	Chamfer Tool, Lower Bore Sleeve		ST-1318
114	H	Tool Bit		ST-1318-23
115	H	Bore Tool, Lower Liner		ST-1287
116	H	Tool Bit		ST-1287-10
117	H	Puller, Shoulder Bolt, Gear Crank		3375081
118	H	Puller, Gear, Crank Bridge Assembly		3375075
119	H	Puller, Jaw, Crankshaft Gear		3375077
120	H	Puller-installer, Oil Seal		ST-1259
121	H	Spacer Ring (1-7/16 In.)		ST-1259-4
122	H	Plate, Top		ST-1259-1
123	H	Spacer Ring (3/16 In.)		ST-1259-2
124	H	Screw, Allen Head (1/4-20 x 1/2 In.)		ST-1259-3
125	H	Screw, Main Puller (1/2-13 x 2 In.)		ST-1259-7
126	H	Screw, Allen Head (1/4-20 x 1-3/4 In.)		ST-1259-5
127	H	Screw, Seal Puller		ST-1259-6
128	H	Clamp, Cylinder Liner	5120-00-104-1816	ST-1184
129	H	Driver		3375153
130	H	Gear & Spacer Mandrel, Lubricating Oil		ST-1157
131	H	Bushing Mandrel, Lubricating Pump		ST-1158
132	H	Bushing Tool, Lubrication Pump Body Cover		3375206
133	H	Bushing, Guide		3375223
134	H	Adapter, Drive		3375229
135	H	Housing, Main Bore		3375220
136	H	Knob, Plastic		3375228
137	H	Dial Indicator		3375227
138	H	Tool Bit		3375226
139	H	Tool Bit		3375225
140	H	Tool Bit		3375207
141	H	Knob, Cutter Adjusting		3375224
142	H	Bushing, Guide		3375221
143	H	Bushing, Guide		3375222
144	H	Orifice Torque	5120-01-072-2955	ST-1090
145	H	Driver, Torque Wrench		ST-1090-1
146	H	Screwdriver		ST-1090-2
147	H	Screw, Set		ST-1090-4
148	H	Wrench, Allen, 5/64 In.		ST-1090-3
149	H	Checking Tool, Injector Protrusion		ST-981

PREVENTIVE MAINTENANCE CHECKS AND SERVICES (PMCS) INSTRUCTIONS (Contd)

Table 4. Tool and Test Equipment Requirements for M915-M920 (Contd).

REF CODE	MAINTENANCE CATEGORY	NOMENCLATURE	NATIONAL STOCK NO.	TOOL NUMBER
150	H	Torque Tool, Injector		ST-1145
151	H	Fixture, Top Stop Injector Setting		3375160
152	H	Tool, Adjusting		3375165
153	H	Crowsfoot, 1-3/8 In., Locknut Wrench		3375166
154	H	Wrench, Inch Pound Torque		3375232
155	H	Block, Weight Carrier		ST-1231
156	H	Puller, Tachometer Drive		ST-1326
157	H	Collar		ST-1326-2
158	H	Collet		ST-1326-1
159	H	Adapter Plate, Fuel Filter		3375014
160	H	Gasket		3375015
161	H	Front Cover, Main Shaft Assembly		3375175
162	H	Driver, Front Cover		3375174
163	H	Driver, Main Shaft Seal		3375173
164	H	Installation Tool, Main Shaft & Bearing		3375172
165	H	Installation Tool, Throttle Shaft Ball		3375204
166	H	Adjust Kit, AFC Fuel Pump		3375189
167	H	Installation Tool, No Air Screw O-Ring		3375148
168	H	Tool, AFC No Air Adjusting		3375140
169	H	Installation Tool, Glyd Ring		3375146
170	H	Forming Tool, Glyd Ring		3375147
171	H	Tool, AFC Adjusting		3375137
172	H	Installation Tool, Cast Governor Weight		3375230
173	H	Mandrel, Tachometer Drive Cup Plug		3375271
174	H	Throttle Travel Template	5120-01-074-0020	3375355
175	H	Turbo Support Block		ST-608
176	H	Socket, Wrench	5120-00-116-7625	ST-1095
177	H	Puller Assembly	5120-00-065-1031	ST-544
178	H	Screw		ST-544-2
179	H	Puller		ST-544-1
180	H	Holder	5120-00-923-0856	ST-851
181	H	Lock Tester, 2 In.		TLN-1000
182	H	Lock Tester, 3 In.		ITL42
183	H	Step Plate, Mechanic	5120-00-473-6921	8B7560
184	H	Bracket		FT901
185	H	Installer		2P8260
186	H	Staking Tool, Pinion Bearing		26883

PREVENTIVE MAINTENANCE CHECKS AND SERVICES (PMCS) INSTRUCTIONS (Contd)

Table 4. Tool and Test Equipment Requirements for M915-M920 (Contd).

REF CODE	MAINTENANCE CATEGORY	NOMENCLATURE	NATIONAL STOCK NO.	TOOL NUMBER
187	H	Carrier Stand		J-3409-1
188	H	Adapter Pot, Injector		3375086
189	H	Assembly Tool, O-Ring	5120-00-396-8089	ST-422
190	H	Assembly Tool, Tube	5120-00-999-1505	ST-835
191	H	Driver, Governor Cylinder	4910-00-150-5801	ST-853
192	H	Adjusting Tool	4910-00-150-5805	ST-984
193	H	Assembly Tool, Tachometer	5120-00-896-8087	ST-1032
194	H	Driver, Seal, Crankshaft	4910-00-150-5810	ST-997
195	H	Pins		ST-997-6
196	H	Wrench, Injector	5120-00-150-7492	ST-995
197	H	Mandrel, Camshaft Bushing	5120-00-055-4013	ST-1228
198	H	Shank, Mandrel		ST-1228-3
199	H	Driver		ST-1228-9
200	H	Puller Assembly		ST-1228-13
201	H	Guide		ST-1228-5
202	H	Guide (2-1/2 In.)		3375154
203	H	Shaft Assembly		ST-1228-4
204	H	Roll Pin		ST-1228-14
205	H	Rod		ST-1228-2
206	H	Slide Hammer		ST-1228-1
207	H	Bushing Driver	4910-00-150-5802	ST-1242
208	H	Block		ST-1242-3
209	H	Cup		ST-1242-2
210	H	Pin, Cotter		ST-1242-6
211	H	Driver (Tapered)		ST-1242-4
212	H	Knock-Out Ring (Tapered)		ST-1242-5
213	H	Knock-Out Ring (Straight)		ST-1242-7
214	H	Driver, Straight		ST-1242-8
215	H	Mandrel		ST-1242-1
216	H	Fixture, Ream, Fuel Pump Front Main	5110-00-981-3107	ST-490
217	H	Puller, Mechanical	5120-00-999-1504	ST-709
218	H	Puller, Bushing		3375108
219	H	Vise, Ball Joint	4910-00-999-5106	ST-302
220	H	Front Seal Assembly	5120-00-896-8097	ST-419
221	H	Gauge, Groove Wear	5210-00-999-1209	ST-560

PREVENTIVE MAINTENANCE CHECKS AND SERVICES (PMCS) INSTRUCTIONS (Contd)

Table 5. Tool and Test Equipment Requirements for M915A1.

REF CODE	MAINTENANCE CATEGORY	NOMENCLATURE	NATIONAL STOCK NO.	TOOL NUMBER
<u>Chassis Tools and Test Equipment</u>				
1	0	Pin, Oil Pan Guide	5315-01-151-1106	J 3387-2
2	0	Indicator Set, Dial	5120-00-402-9619	J 7872
3	0	Driver, Bushing	5120-01-159-1841	700291
4	0	Wrench, Hexagon Locknut, 4-1/8 Inch	5120-01-145-5793	1915
5	0	Wrench, Hexagon Locknut, 2-1/4 Inch	5120-01-089-9068	1920
6	0	Analyzer, Power Steering		J 26487
7	0	Bar, Holding, Pinion Yoke and Flange		J 3453
8	0	Handle		450237
9	0	Adapter		427
10	0	Plug, Bearing		706
11	0	Adapter		446
12	0	Plug, Bearing		715
13	0	Removal Tool, Contact	5120-01-158-4707	114010
14	0	Removal Tool, Contact	5120-01-158-4708	0411-204- 1605
15	0	Crimping Tool	5120-00-251-3990	5417
16	0	Crimping Tool		MS3191A
17	00	Locator, Socket Contact	5120-01-131-0138	600092
18	0	Insertion Tool, Contact	5120-01-131-0140	CIT-F80-16
19	0	Extraction Tool, Contact	5120-01-131-0139	CET-F80-16
20	0	Tester, Lock Fifth Wheel, 2 Inches	5120-01-097-0170	TLN-1000
21	F	Remover, Seal and Dust Shield	5120-01-048-2153	J 24171
22	F	Installer, Output Shaft Seal	5120-01-159-1852	J 24202-1A
23	F	Handle, Driver	5120-01-054-4048	J 24202-4
24	F	Jack, Transmission	4910-00-585-3622	49
25	F	Tool, Spanner		294514
26	F	Service Set, Torque Rod Bushing	4910-01-159-1734	Y-820
27	F	Service Set, Equalizing	5180-01-084-6010	Y-850-A
28	F	Tube, Receiving	4910-01-159-1735	Y-860
29	F	Adapter, Removing	5120-01-159-1843	Y-861
30	F	Adapter, Installing	5120-01-159-1845	Y-862
31	F	Remover and Installer, Windshield		C-4009-B
32	H	Handle, Driver	5120-00-677-2259	J 8092
33	H	Gauge, Clearance Clutch Pack, 0.080–0.120 Inch	5210-01-048-2161	J 24192
34	H	Gauge, Clearance, Clutch Pack, 0.060–0.120 Inch	5210-01-048-2162	J 24193

PREVENTIVE MAINTENANCE CHECKS AND SERVICES (PMCS) INSTRUCTIONS (Contd)

Table 5. Tool and Test Equipment Requirements for M915A1 (Contd).

REF CODE	MAINTENANCE CATEGORY	NOMENCLATURE	NATIONAL STOCK NO.	TOOL NUMBER
35	H	Gauge, Clearance, Clutch Pack, 0.095–0.145 Inch	5210-01-048-5283	J 24194
36	H	Bracket, Lifting, Center Support	5210-01-116-6048	J 24195
37	H	Bracket, Lifting, Mainshaft	5210-01-115-1157	J 24196
38	H	Installer, Bearing, Front Support Hub	5120-01-115-1160	J 24197
39	H	Installer, Oil Seal, Oil Pump	5120-01-054-4049	J 24198
40	H	Installer and Staking Set, Collector Ring	5120-01-048-3124	J 24200
41	1	Installer, Bushing, Output Shaft	5120-01-115-9174	J 24203
42	H	Compressor, Clutch Spring	5120-01-048-3129	J 24204
43	H	Installer and Remover, Speedometer Bushing	5120-01-116-5017	J 24205-A
44	H	Installer, Sleeve, Front Planetary Bushing	4910-01-158-3989	J 24207
45	H	Compressor Set, Center Support	5120-01-116-5016	J 24208-C
46	H	Fixture, Lifting, Fourth Clutch	5120-01-115-1159	J 24209
47	H	Protector, Inner Seal, Clutch Piston	5120-01-048-2156	J 24210
48	H	Protector, Seal, Forward Clutch	5120-01-048-2157	J 24216-01
49	H	Installer Mainshaft Orifice	5120-01-115-1162	J 24217
50	H	Ring Retainer, Stator Camspring and Roller	5120-01-115-1158	J 24218-2
51	H	Compressor, Spring	5120-01-048-2160	J 24219
52	H	Fixture, Alignment, Fourth Clutch	5120-01-115-1156	J 24221
53	H	Fixture, Holding, Transmission	5120-01-115-1165	J 24310
54	H	Pin Set, Guide	5120-01-115-1163	J 24315
55	H	Lifting Tool, Flywheel	5120-01-116-6049	J 24365
56	H	Installer, Bushing, Rear Planetary Carrier	5120-01-159-1844	J 24368
57	H	Installer, Orifice Plug	5120-01-054-4053	J 24369
58	H	Puller, Universal	5120-00-999-4053	J 24420
59	H	Installer, Bearing, Rear	5120-01-054-4054	J 24447
60	H	Installer, Retaining Ring	5120-01-054-4050	J 24453
61	H	Remover, Rear Bearing, In-Vehicle	5120-01-054-0188	J 24534
62	H	Installer, Seal, Shift Lever	5120-01-115-1161	J 26282
63	H	Remover, Seal, Shift Lever	5120-01-118-6264	J 26401
64	H	Remover and Installer, Snapping, Pump		J 26598-A
65	H	Staking Tool, Bushing, Sun Gear		J 26997-A
66	H	Reamer Set, Bushing, Sun Gear	5110-01-150-9755	J 28489
67	H	Installer and Staking Set, Bushing, Center Support	4910-01-158-3971	J 28525

PREVENTIVE MAINTENANCE CHECKS AND SERVICES (PMCS) INSTRUCTIONS (Contd)

Table 5. Tool and Test Equipment Requirements for M915A1 (Contd).

REF CODE	MAINTENANCE CATEGORY	NOMENCLATURE	NATIONAL STOCK NO.	TOOL NUMBER
68	H	Installer, Bearing	5120-01-159-1842	J 28646-A
69	H	Installer, Pin, Governor Support	5120-01-122-1179	J 28684
70	H	Gauge, Ring, Center and Front Support Seal	5210-01-133-6888	J 29198-3
71	H	Lifter, Clutch Assembly	4910-01-159-1736	J 33079
72	H	Remover and Installer, Driven Gear Shaft		J 33080
73	H	Scale, Tension	4910-00-779-6832	J 8129
74	H	Staking Tool		J 26883
75	H	Stand, Repair, Differential	4910-01-085-7729	J 3409-01
76	H	Compressor, Spring, Slider		TLN-2500
77	H	Driver Bushing	4910-01-158-3986	J 24201
78	H	Adjusting Tool, Valve Ring		J 24314
79	H	Fixture Set, Gear Removing		J 26899
		<u>Engine Tools and Test Equipment</u>		
80	O	Gauge, Manifold Pressure	6220-01-147-9954	ST-1273
81	O	Mandrel, Thermostat Seal	4910-01-097-6948	ST-1225
82	O	Wrench, Oil and Fuel Filter, Spin-On	5120-01-160-8863	3375049
83	F	Fixture, Engine Lifting	2815-00-362-2042	ST-125
84	F	Tool, Valve Seat Insert	4910-00-345-3708	ST-257
85	F	Vise, Ball Joint	4910-00-999-1506	ST-302
86	F	Compressor, Valve Spring	5120-01-145-7293	ST-448
87	F	Fixture, Head Holding	4920-00-711-9307	ST-583
88	F	Spacer, Crosshead Guide	4910-00-150-5797	ST-633
89	F	Mandrel, Water Pump Bearing	4910-00-097-6986	ST-658
90	F	Cutter, Valve Seat Insert	5133-00-999-1208	ST-662
91	F	Arbor, Valve Guide	3640-00-999-1173	ST-663
92	F	Adapter, Torque Wrench	5120-00-103-4687	ST-669
93	F	Block and Mandrel, Rocker Lever	3460-00-999-1210	ST-691
94	F	Plate, Air Compressor Mounting	4910-01-159-8701	ST-749
95	F	Tool, Bead Cutting	5110-00-932-2089	ST-788
96	F	Tool, Injector Seat Cutting	4910-00-925-0755	ST-824
97	F	Brush, Fuel Passage Cleaning	7920-00-168-3244	ST-876
98	F	Expander, Injector Sleeve	3441-00-922-6699	ST-880
99	F	Cutter, Injector Seat	4910-00-981-3105	ST-884
100	F	Driver, Crankshaft Oil Seal	4910-00-150-5810	ST-997
101	F	Mandrel, Air Compressor Bushing		ST-1105
102	F	Fixture, Bearing Disassembly	4910-01-097-6987	ST-1114
103	F	Driver, Valve Seat Insert		
		Staking Tool	4910-00-150-5843	ST-1122
104	F	Pilot, Valve Seat Insert		
		Staking Tool	4910-00-150-5844	ST-1124

PREVENTIVE MAINTENANCE CHECKS AND SERVICES (PMCS) INSTRUCTIONS (Contd)

Table 5. Tool and Test Equipment Requirements for M915A1 (Contd).

REF CODE	MAINTENANCE CATEGORY	NOMENCLATURE	NATIONAL STOCK NO.	TOOL NUMBER
105	F	Mandrel, Seal Wear Sleeve	4910-01-097-6988	ST-1159
106	F	Mandrel, Seal	4910-01-161-2115	ST-1173
107	F	Tool, Injector Sleeve Holding	5120-00-104-1795	ST-1179
108	F	Driver, Oil Seal	5120-01-160-8867	ST-1191
109	F	Driver, Injector Sleeve	5120-00-981-3108	ST-1227
110	F	Puller, Injector Sleeve	5120-00-113-5271	ST-1244
111	F	Puller	5120-01-128-2678	3376663
112	F	Tester, Valve Vacuum	4910-01-128-2691	ST-1257-A
113	F	Installer, Oil Seal	4910-01-106-0492	ST-1259
114	F	Extractor, Valve Seat		ST-1279
115	F	Attachment, Dial Gauge	5120-01-128-2679	ST-1325
116	F	Tool, Blowby Checking		3375150
117	F	Expander, Oil Seal	4910-01-097-6972	3375151
118	F	Wrench, Air Compressor	4910-01-085-9211	3375159
119	F	Puller, Injector	5120-01-072-2952	3375161
120	F	Pilot, Oil Seal	4910-01-097-6989	3375180
121	F	Tester, Spring	4910-01-142-4929	3375182
122	F	Driver, Expansion Plug, 3/4"	4910-01-143-3336	3375190
123	F	Driver, Expansion Plug, 1"	4910-01-143-3337	3375191
124	F	Driver, Expansion Plug, 1-1/4"	4910-01-143-2023	3375192
125	F	Puller	5120-01-155-3795	3375257
126	F	Driver, Valve Guide	4910-01-097-6971	3375282
127	F	Mandrel, Water Pump Seal	5120-01-128-2675	3375448
128	F	Dial Indicator and Sleeve Assembly	5120-01-157-2291	3376050
129	F	Assembly Tool, Pulley Installation	5120-01-156-4183	3376326
130	F	Wrench, Solenoid Valve		011494
131	F	Socket, Special, 5/8" X 1/2" Drive		SINL-200
132	H	Fixture, Ream	5110-00-981-3107	ST-490
133	H	Gauge, Piston Ring Groove	5210-00-999-1209	ST-560
134	H	Fixture, Connecting Rod Checking	4910-00-977-7507	ST-561
135	H	Mandrel, Connecting Rod Locating	4910-01-146-7130	ST-563
136	H	Tool, Burnishing	4910-00-999-1503	ST-708
137	H	Puller, Governor Weight	5120-00-999-1504	ST-709
138	H	Expander, Piston Ring	5120-00-150-7486	ST-763
139	H	Wrench, Injector Cup	5120-00-150-7492	ST-995
140	H	Extension, Plunger	4910-00-150-5819	ST-1089
141	H	Extractor, Dowel Pin	4910-00-150-5848	ST-1134
142	H	Mandrel, Spacer	4910-01-097-6913	ST-1157
143	H	Puller, Main Bearing Cap	5120-01-141-5777	ST-1178

PREVENTIVE MAINTENANCE CHECKS AND SERVICES (PMCS) INSTRUCTIONS (Contd)

Table 5. Tool and Test Equipment Requirements for M915A1 (Contd).

REF CODE	MAINTENANCE CATEGORY	NOMENCLATURE	NATIONAL STOCK NO.	TOOL NUMBER
144	H	Clamp, Cylinder Liner	5120-00-104-1816	ST-1184
145	H	Driver, Liner	5120-00-999-1206	ST-1229
146	H	Tool, Plunger Protrusion Checking	4910-01-141-8388	ST-1241
147	H	Driver, Connecting Rod Bushing	4910-01-098-1914	ST-1242
148	H	Conversion Kit	4910-01-147-7896	ST-1261
149	H	Injector, Master K	4910-01-154-6406	ST-1262
150	H	Stand, Injector	4910-01-082-1346	ST-1298
151	H	Pot, Injector Adapter	4910-00-185-8508	3375086
152	H	Plate, Fuel Pump Mounting	4910-01-128-2685	3375133
153	H	Fixture, Setting, Top Stop Injector	4910-01-097-6926	3375160
154	H	Compressor, Piston Ring	5120-01-128-2758	3375162
155	H	Tool Kit, AFC Fuel Pump Adjusting, Tool	5180-01-102-8418	3375189
156	H	Tool, Installing, Throttle Shaft Ball	4910-01-118-3747	3375204
157	H	Kit, Crack Detection	6850-00-145-0255	3375432
158	H	Tool, Cylinder Block Counterbore	4910-01-150-9713	3375455
159	H	Fixture, Injection Timing	4910-00-999-1269	3375522
160	H	Puller, AFC Barrel	5120-01-128-2688	3375599
161	H	Pin, Connecting Rod Guide		3375601
162	H	Indicator, Level & Angle	4910-01-074-0020	3375855
163	H	Driver, Pressurizing Valve	4910-01-143-2034	3375959
164	H	Tool, Adjusting, Fuel Pump Idle	4910-00-150-5805	3375981
165	H	Fixture, AFC Pressure Valve	4910-01-152-2743	3376011
166	H	Puller, Cylinder Liner, Universal	5120-01-143-2032	3376015
167	H	Driver, Lock Cup	4910-00-150-5801	3376136
168	H	Block, Gauge	5210-01-157-3091	3376220
169	H	Wrench, Torque, Inch-Pound	4910-01-097-6929	3376592
170	H	Kit, Camshaft Bushing Driver	5120-01-146-7131	3376633
171	H	Driver, Camshaft Bushing	5120-01-156-6186	3376637
172	H	Oil Seal Assembly Tool	5120-00-896-8097	ST-419
173	H	Front Cover and Mainshaft Assembly Tool		3375175
174	H	Tester, Injector Leakage		ST-990
175	H	Stand, Injector Test		ST-790
176	H	Tester, Injector Cup Spray	5120-01-029-6861	ST-668
177	H	Link	4910-01-128-9810	ST790-362
178	H	Orifice	4910-00-999-1501	ST790-363
179	H	Injector Adapter Pot		ST-1254
180	H	Kit, K-Cam		J 33113

**DIRECT SUPPORT AND GENERAL SUPPORT
MAINTENANCE MANUAL
INCLUDING REPAIR PARTS AND SPECIAL TOOLS LIST (RPSTL)**

FOR

M915, M915A1, M915A4, M916, M920 VEHICLES

NSN 2815-01-082-8125	P/N NTC400-3652-02	CUMMINS NTC-400 BIG CAM I DIESEL ENGINE W/CONTAINER
NSN 2815-01-142-2745	P/N 11669835	CUMMINS NTC-400 BIG CAM III DIESEL ENGINE W/CONTAINER

BIG CAM I ENGINE REMOVAL

INITIAL SETUP:

Tools and Special Tools

General mechanic's tool kit: automotive
(Item 1, WP 0061 00)
Maintenance and repair shop equipment:
automotive (Item 2, WP 0061 00)
Automotive maintenance and repair
supplemental set no.2
(Item 3, WP 0061 00)
Lifting brackets (Item 43, WP 0061 00)
Lifting sling (Item 42, WP 0061 00)

Equipment Condition

Horn wire removed (TM 9-2320-283-20).
Grille shell removed (TM 9-2320-283-20).
Air cleaner removed (TM 9-2320-283-20).
Fan removed (TM 9-2320-283-20).
Fenders removed (TM 9-2320-283-20).
Upper radiator fan shroud removed
(TM 9-2320-283-20).
Radiator support brackets removed
(TM 9-2320-283-20).
Radiator and support rods removed
(TM 9-2320-283-20).
Turbocharger exhaust tube removed
(TM 9-2320-283-20).
Cooling system hoses removed
(TM 9-2320-283-20).
Power steering pump hydraulic lines removed
(TM 9-2320-283-20).

Equipment Condition (Contd)

Steering system to proper level removed
(TM 9-2320-283-12).
Transmission oil cooler lines removed
(TM 9-2320-283-20).
Steering system drained
(TM 9-2320-283-12).
Bumper and towing eyes removed
(TM 9-2320-283-20).
Brush guard and spotter mirrors removed
(TM 9-2320-283-20).
Air reservoir draincocks opened
(TM 9-2320-283-20).
Battery cables disconnected
(TM 9-2320-283-20).
Engine oil drained (TM 9-2320-283-12).
Hood removed (TM 9-2320-283-20).
Cooling system drained
(TM 9-2320-283-12).

Personnel Required

Two assistants

BIG CAM I ENGINE REMOVAL (Contd)

1. Position and secure suitable transmission jack under transmission (3). Ensure transmission weight is supported by transmission jack.
2. Remove flywheel bolt access cover screw (8) securing breather tube clamp (9) to flywheel housing (6) and position breather tube clamp (9), and breather tube (10) away from flywheel housing (6).
3. Remove flywheel bolt access cover screw (8) and flywheel bolt access cover (11) from flywheel housing (6).

NOTE

Rotate engine using accessory drive pulley nut to gain access to flywheel bolts.

4. Remove twelve flywheel bolts (1) and washers (2) securing ring gear (5) to flywheel (4) through flywheel bolt access hole (7).
5. Loosen two lower alternator screws (12) securing alternator (30) to alternator mounting bracket (27).
6. Remove alternator bolt (25), washer (24), and nut (13) securing alternator (30) to alternator adjusting rod block (23).
7. Remove alternator adjusting rod bolt (18), lockwasher (17), washer (16), alternator adjusting rod (20), alternator adjusting rod block (23), three alternator adjusting rod nuts (21) and two washers (22) as an assembly, from engine (14). Discard alternator adjusting rod lockwasher (17).

NOTE

Rotate alternator in towards engine to allow for clearance during engine removal.

8. Rotate alternator (30) in towards engine (14) and tighten two lower alternator screws (12) to retain alternator (30) in position.
9. Remove two belts (19) from alternator pulley (26) and crankshaft pulley (15). Discard belts (19).
10. Remove two lower alternator screws (12), nut (28), washer (29), and alternator (30) from alternator mounting bracket (27).

BIG CAM I ENGINE REMOVAL (Contd)

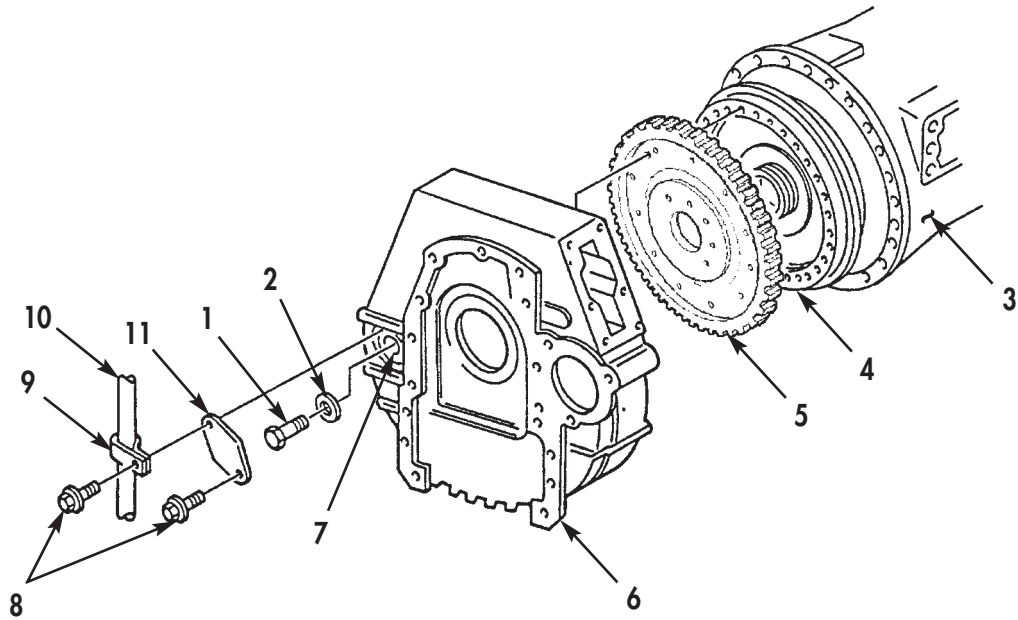


Figure 1. Ring Gear Removal.

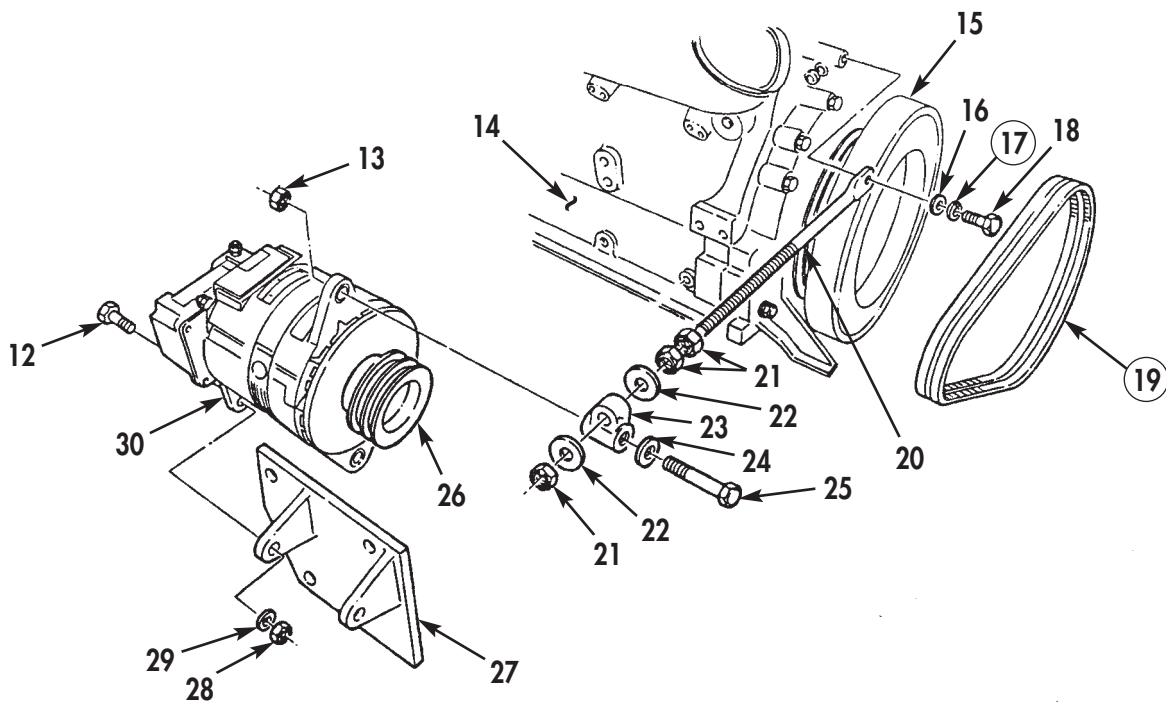


Figure 2. Alternator Belt Removal.

BIG CAM I ENGINE REMOVAL (Contd)

11. Remove heater hose clamp (2) and heater valve (1) from heater hose (3).

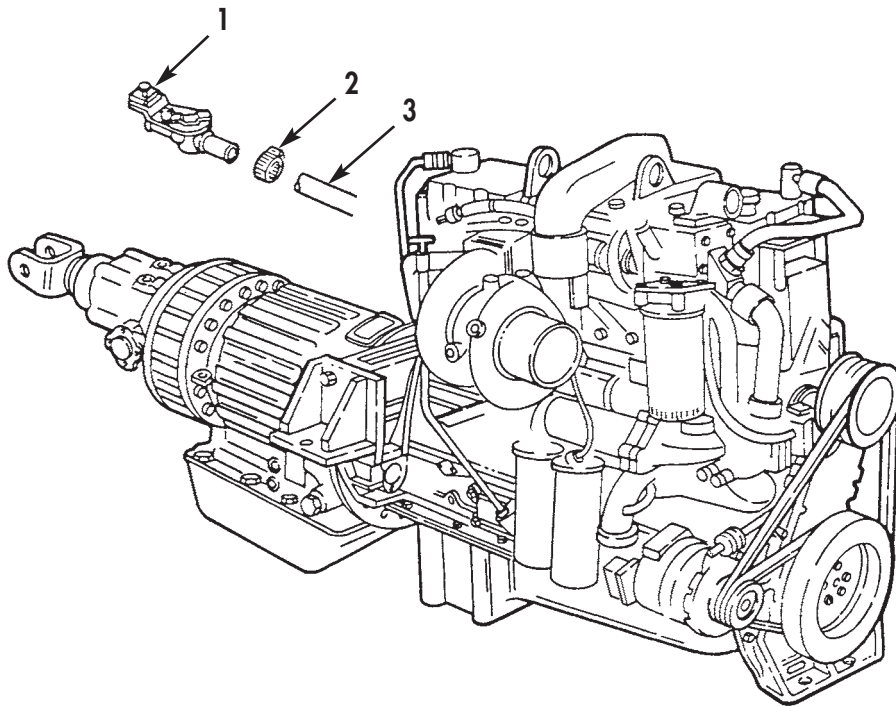


Figure 3. Heater Valve Removal.

BIG CAM I ENGINE REMOVAL (Contd)

12. Remove three heater hose nuts (4) and screws (8) retaining hoses (6) and (12), clamps (5), and starter battery cable (7) from mounting brackets (9).
13. Disconnect heater hose adapter (10) from water outlet fitting (11).
14. Position heater hose (6) and (12), clamps (5), and starter battery cable (7) aside to allow clearance for engine removal.

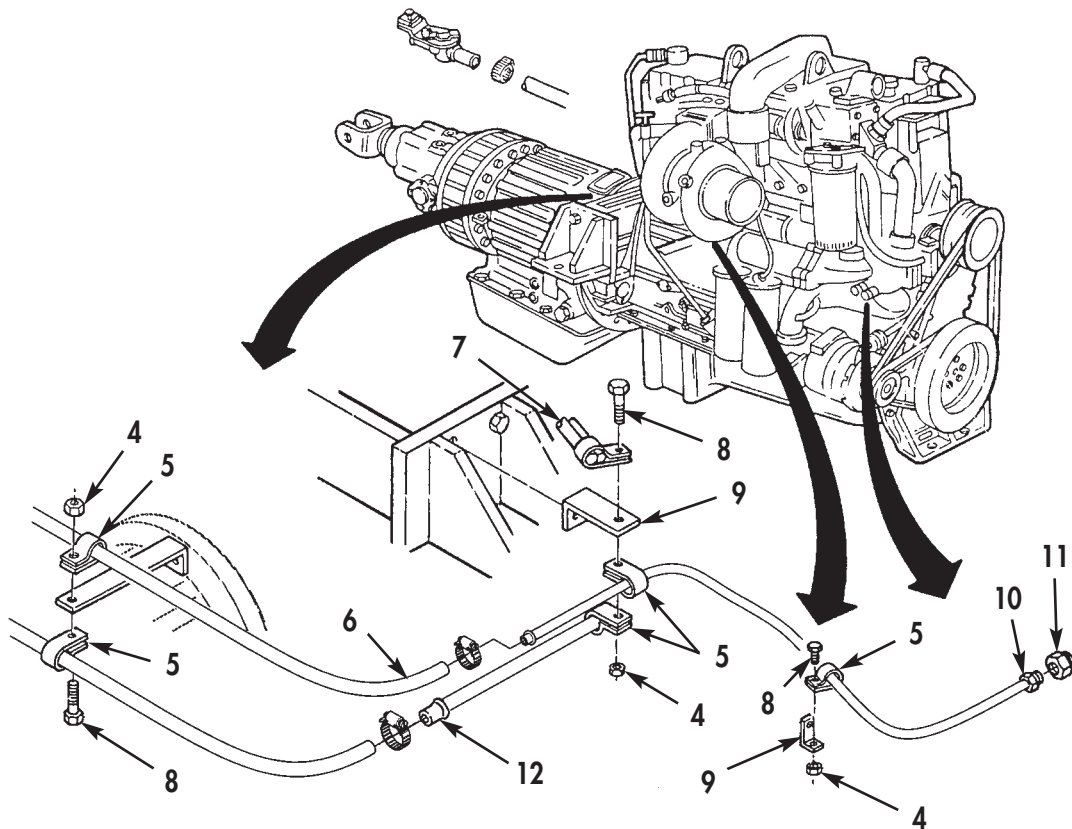


Figure 4. Heater Hose and Starter Wiring Harness Removal.

BIG CAM I ENGINE REMOVAL (Contd)

15. Disconnect engine harness electrical connectors (1) at firewall (2).
16. Remove engine harness screw (3) and engine harness bracket (4) from engine (5).
17. Disconnect air compressor line (6) from air compressor (7).
18. Disconnect fuel line (10) from fuel filter and damper (11).
19. Disconnect tachometer shaft assembly (15) from tachometer (14).
20. Cut plastic tie (9) securing tachometer shaft assembly (15) to ether quick start kit bracket (8). Discard plastic tie (9).
21. Remove ether quick start kit bracket nut (17), screw (12), two clamps (13) and (16) and ether quick start kit bracket (8) from engine (5).
22. Cut plastic tie (21) securing speedometer shaft assembly (22) to fuel return line (20). Discard plastic tie (21).
23. Disconnect fuel return line (20) from fuel rail male branch tree (19).
24. Disconnect air compressor hose (23) from air compressor line (24).
25. Disconnect air compressor line (25) from air compressor line T-adapter (18).

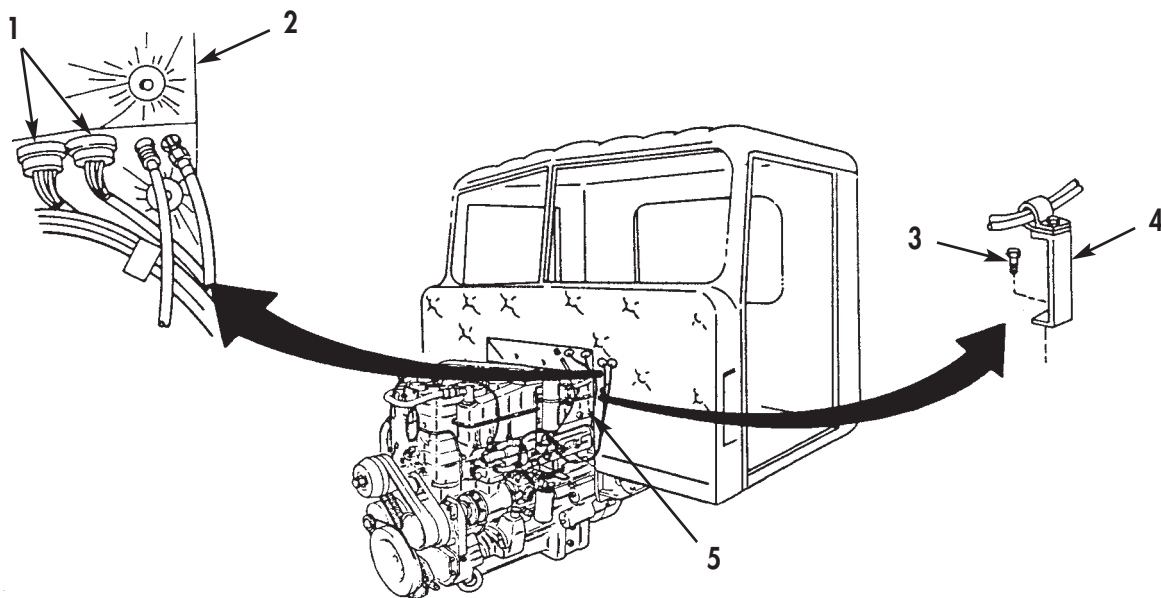


Figure 5. Firewall Electrical Harness Disconnections.

BIG CAM I ENGINE REMOVAL (Contd)

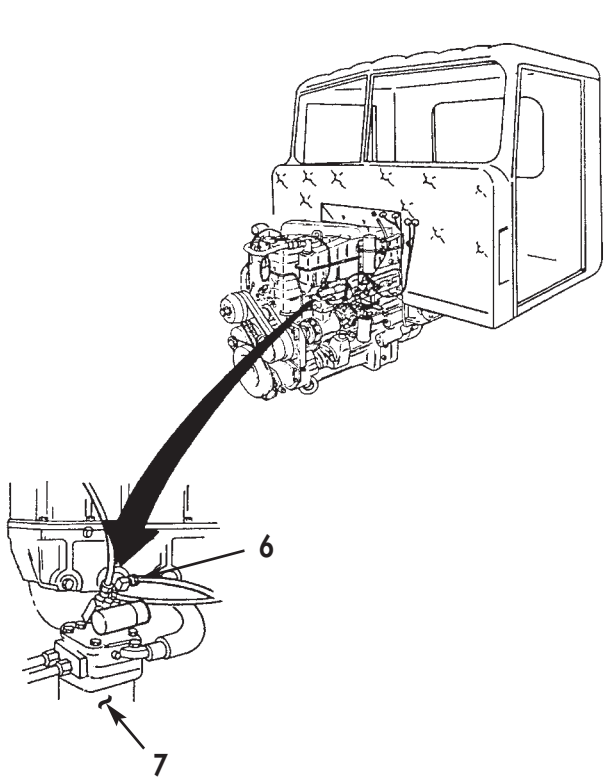


Figure 6. Air Compressor Disconnection.

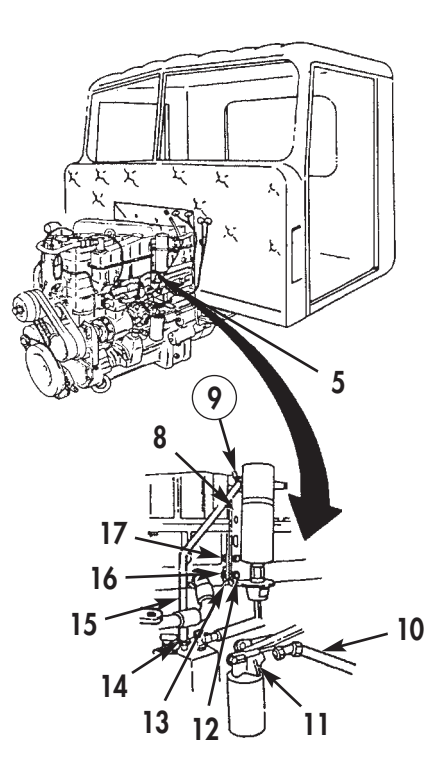


Figure 7. Fuel Filter and Lines Removal.

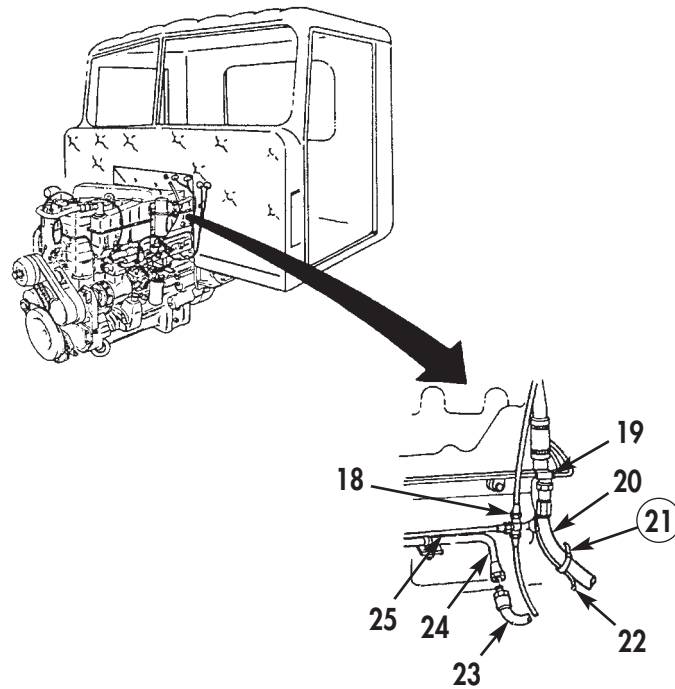


Figure 8. Fuel and Air Compressor Lines Disconnection.

BIG CAM I ENGINE REMOVAL (Contd)

26. Remove return spring (5) from transmission modulator control bracket (6) and return spring clip (4).
27. Remove accelerator link nut (2), washer (3), spring clip (4), and accelerator link (15) from fuel control lever pin (17).
28. Remove retaining pin (13), washer (14), and transmission modulator control link (16) from fuel control lever (18). Discard retaining pin (13).
29. Remove two nuts (12), washers (11), shim (10), and U-bolt (9) from transmission modulator control bracket (6).
30. Remove two transmission modulator control bracket bolts (8), lockwashers (7), and transmission modulator control bracket (6) from engine (1). Discard lockwashers (7).
31. Remove ground strap bolt (33), starwasher (32), ground strap (34), and starter motor ground strap (31) from engine (1). Discard star washer (32).
32. Remove two starter motor terminal nuts (30), lockwashers (29), negative battery cable (28), and positive battery cable (26) from starter motor (27). Discard lockwashers (29).
33. Remove front hose clamp screw (35), nut (38), and hose clamp (36) from cooler hose bracket (37).
34. Remove middle cooler hose bracket screw (25) and middle cooler hose bracket (23) from oil pan (24).
35. Remove rear cooler hose bracket screw (22), washer (21), and rear cooler hose bracket (20) from transmission (19).

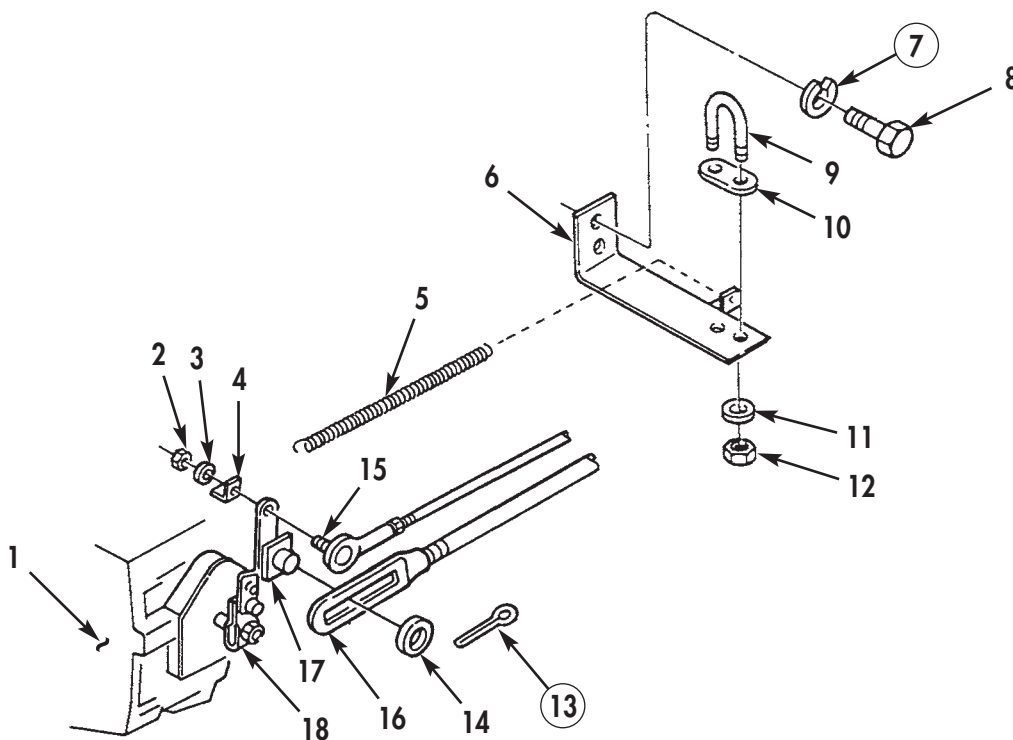


Figure 9. Accelerator Cable Disconnection.

BIG CAM I ENGINE REMOVAL (Contd)

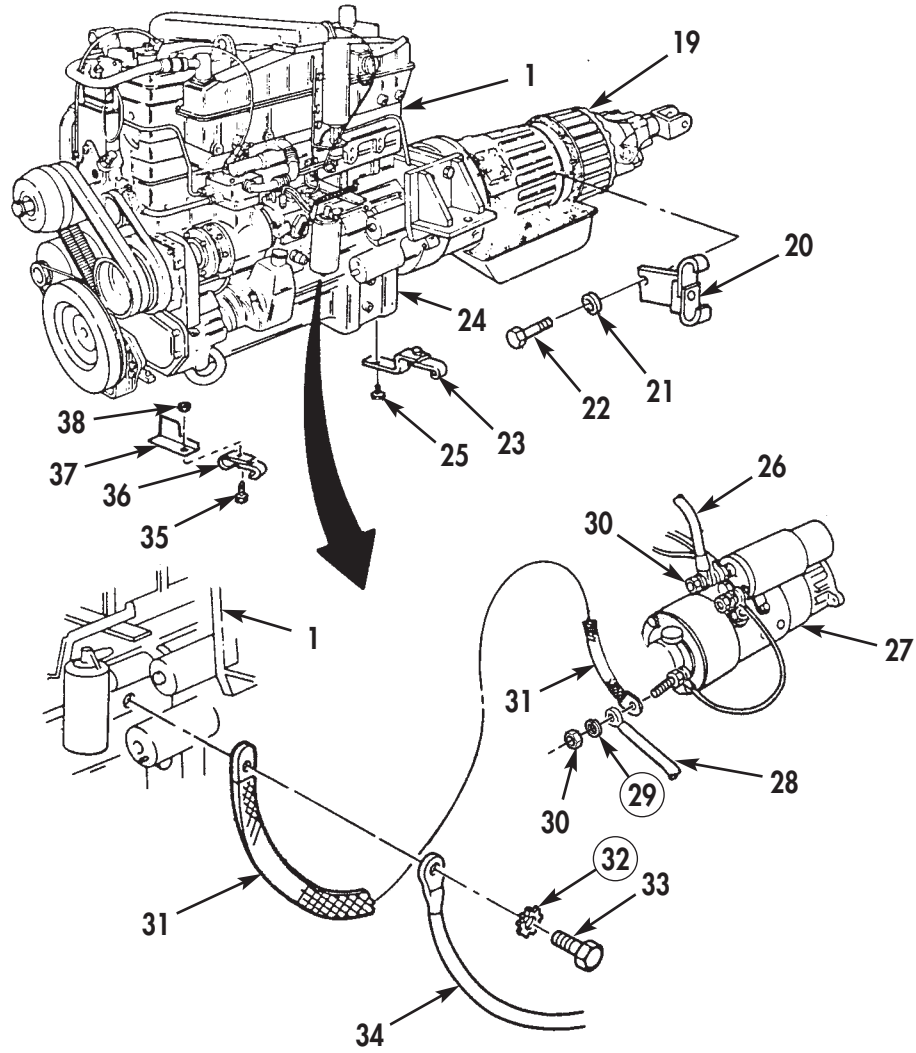


Figure 10. Starter Cables Removal.

BIG CAM I ENGINE REMOVAL (Contd)

36. Remove two locknuts (10), lockwashers (9), U-bolt (5), shim (4), and cable mounting bracket (11) from shift control cable (12). Discard locknuts (10) and lockwashers (9).
37. Remove trunnion retaining pin (7) and trunnion (8) from transmission shift lever (6).
38. Remove floor mat (2) from floor pan access cover (1).
39. Remove ten screws (3), floor pan access cover (1), and shifter (13) from cab floor.
40. Remove transmission temperature sending unit nut (35), washer (36), and electrical connector (37) from transmission temperature sending unit (38).
41. Remove twelve transmission bolts (30) securing transmission (26) to engine (18).
42. Install two lifting brackets (17) on top of engine (18) with four bolts (16).
43. Install lifting sling and lifting device on engine lifting brackets (17).
44. Remove two rear engine mount nuts (29), washers (31) and bolts (14) from frame (32).
45. Remove two front engine mount nuts (27), bolts (24) and washers (23) from crossmember (25).

WARNING

Use extreme care when handling heavy parts. Provide adequate support and use assistance during procedure. Ensure that any lifting device used is in good operating condition and of suitable load capacity. Keep clear of heavy components supported only by lifting device. Failure to do so may result in death or injury to personnel.

CAUTION

Raise engine slowly and carefully to prevent damage to splined shaft. Failure to comply may result in damage to engine.

46. Using lifting device and lifting sling, raise engine and remove two rear frame flat washers (34) and rear vibration insulators (33) from rear engine mounting brackets (15).

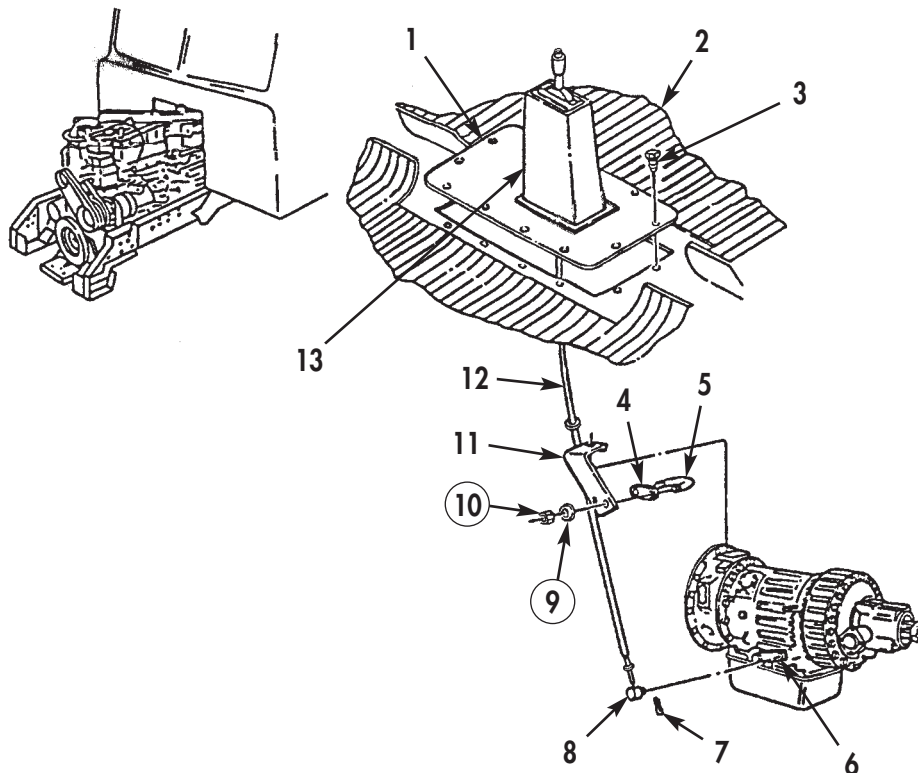


Figure 11. Shifter Removal.

BIG CAM I ENGINE REMOVAL (Contd)

47. Remove two front frame flat washers (20) and front vibration insulators (21) from front engine crossmember (25).
48. Using lifting device and lifting sling, remove engine (18) from frame (32). Ensure there is proper clearance between frame (32), alternator (28), engine (18), and power steering pump (22).
49. Install engines in approved engine container.

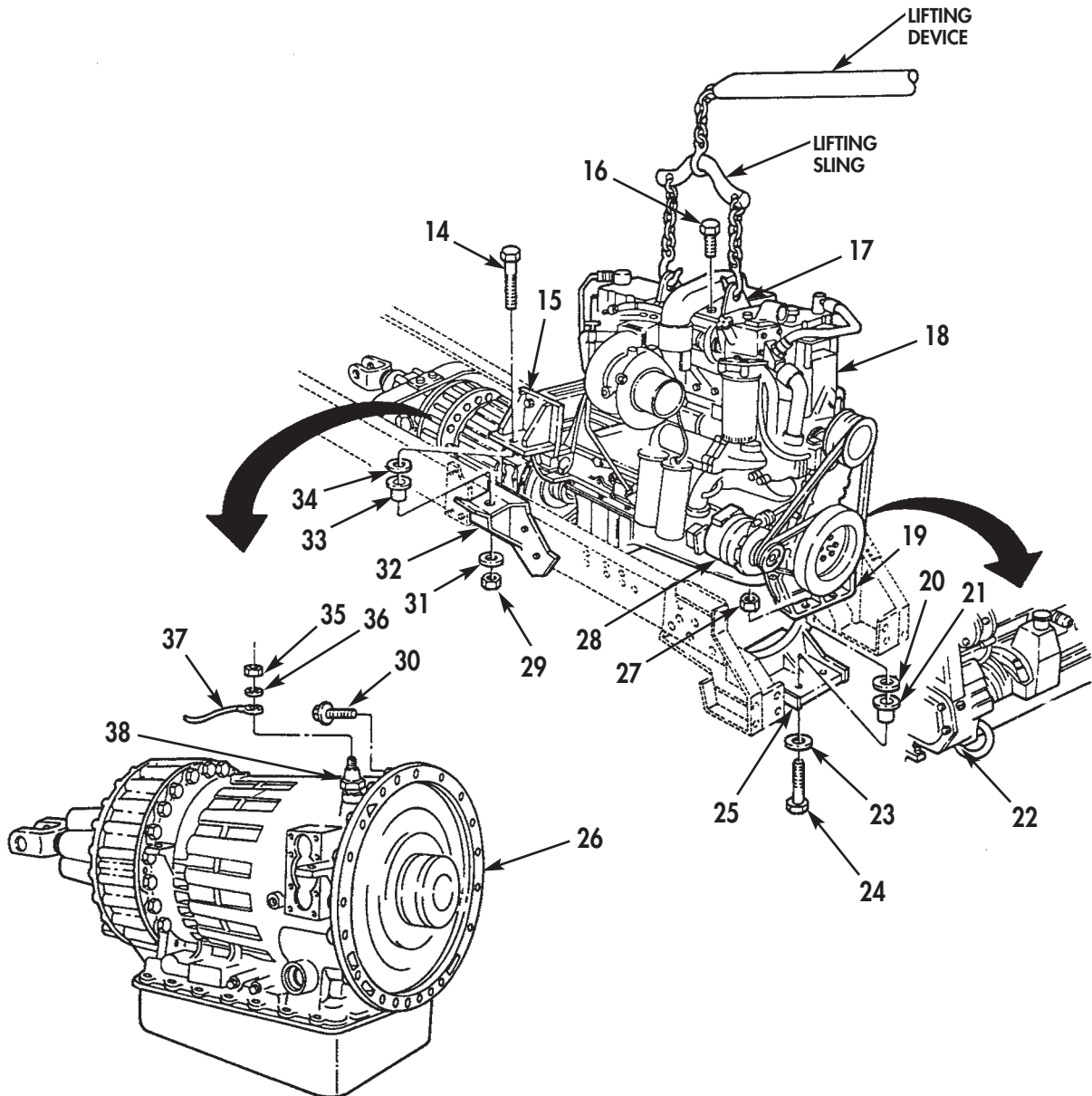


Figure 12. Engine Removal.

END OF WORK PACKAGE

0007 00-11/12 blank

**DIRECT SUPPORT AND GENERAL SUPPORT
MAINTENANCE MANUAL
INCLUDING REPAIR PARTS AND SPECIAL TOOLS LIST (RPSTL)**

FOR

M915, M915A1, M915A4, M916, M920 VEHICLES

NSN 2815-01-082-8125	P/N NTC400-3652-02	CUMMINS NTC-400 BIG CAM I DIESEL ENGINE W/CONTAINER
NSN 2815-01-142-2745	P/N 11669835	CUMMINS NTC-400 BIG CAM III DIESEL ENGINE W/CONTAINER

BIG CAM III ENGINE REMOVAL

INITIAL SETUP:

Tools and Special Tools

General mechanic's tool kit: automotive
(Item 1, WP 0061 00)
Maintenance and repair shop equipment:
automotive (Item 2, WP 0061 00)
Automotive maintenance and repair
supplemental set no. 2 (Item 3, WP 0061 00)
Tilt sling (Item 67, WP 0061 00)
Lifting sling (Item 42, WP 0061 00)

Personnel Required

Three assistants

Equipment Condition

Horn wire disconnected (TM 9-2320-283-20).
Grille shell removed (TM 9-2320-283-20).
Fenders removed (TM 9-2320-283-20).
Upper radiator fan shroud removed
(TM 9-2320-283-20).
Steering system to proper level removed
(TM 9-2320-283-12).
Transmission lines removed
(TM 9-2320-283-20).
Air reservoir draincocks opened
(TM 9-2320-283-20).
Bumper and towing eyes removed
(TM 9-2320-283-20).
Brush guard and spotter mirrors removed
(TM 9-2320-283-20).

BIG CAM III ENGINE REMOVAL (Contd)

1. Disconnect two negative battery cable clamps (2) from two negative battery cable post (3) and remove negative battery cable (1) from battery (4).
2. Open drain valve (6) on cooling tube outlet (5) and drain engine coolant from engine. When finished, close drain valve (6).
3. Remove drain plug (7) from oil pan (8) and drain engine oil from oil pan (8). Install drain plug (7) in oil pan (8).

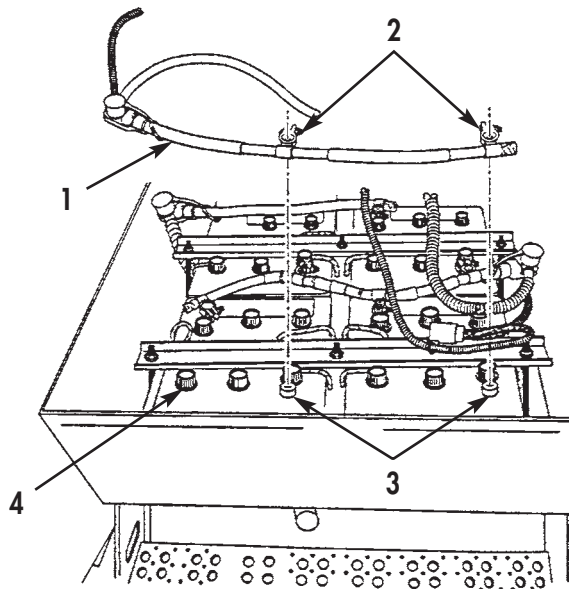


Figure 1. Battery Cable Removal.

BIG CAM III ENGINE REMOVAL (Contd)

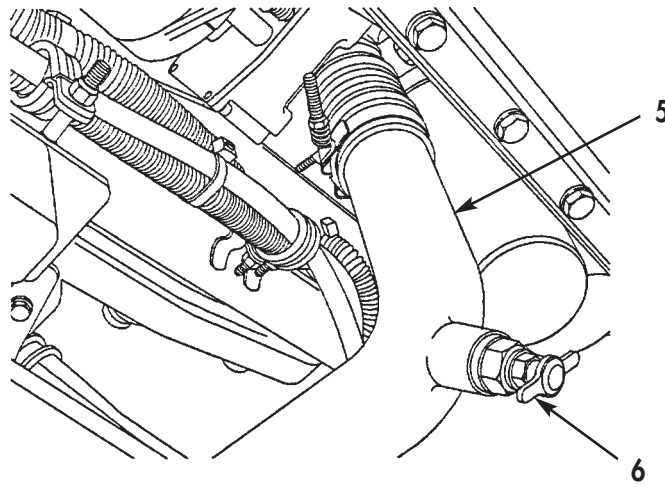


Figure 2. Draining Engine Coolant.

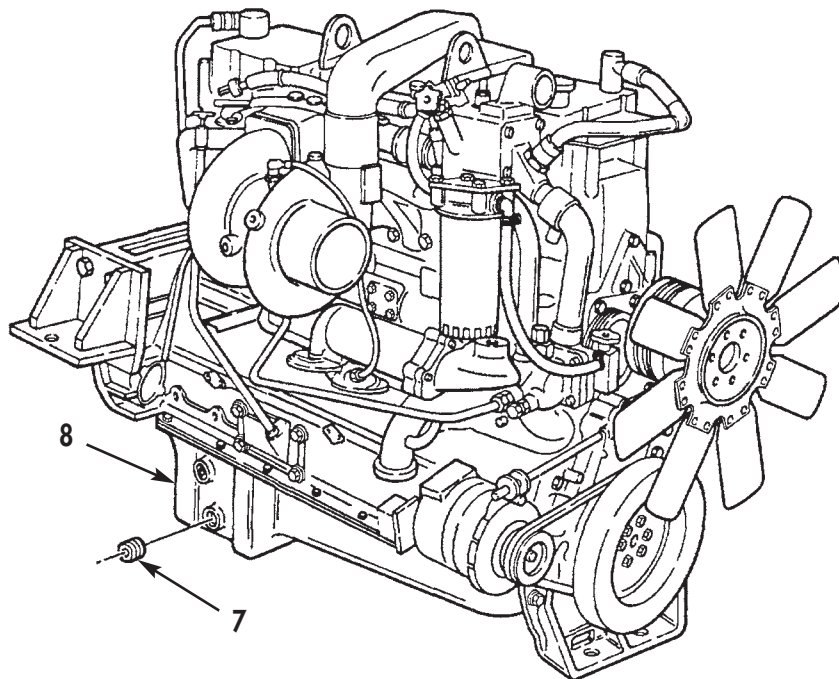


Figure 3. Oil Drain Plug Removal.

BIG CAM III ENGINE REMOVAL (Contd)**CAUTION**

Mark and tag all wires, hoses, etc., removed from vehicle for proper reinstallation. Failure to comply may result in damage to equipment.

4. Disconnect four lighting harness electrical connectors (4).
5. Remove four lighting harness screws (3), washers (2), and clamps (1) from lights and hood (5).
6. Cut plastic tie (6) and remove lighting harness (7) from hood (5) and position aside. Discard plastic tie (6).

WARNING

When removing hood tilt assist cables, hood must be supported. Failure to do so may result in damage to equipment or injury to personnel.

7. Support hood (5) and open two chain link nuts (10). Remove tilt assist cables (8) from chain links (9).
8. Close hood (5) and remove two hood hinge locknuts (11) and bolts (12) from hood hinges (13). Discard locknuts (11).

NOTE

Use three assistants or lifting strap and lifting device to remove hood from vehicle.

9. Remove hood (5) from vehicle.

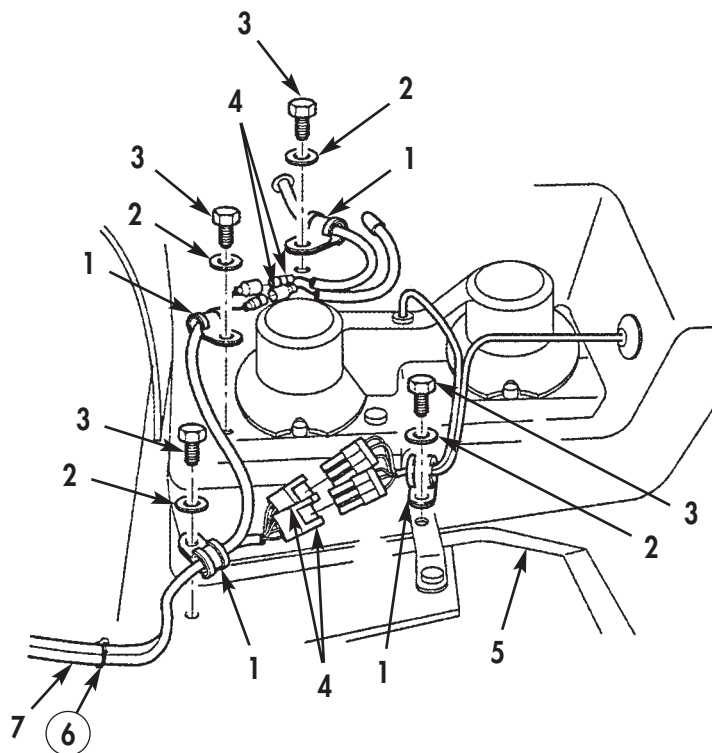


Figure 4. Lighting Harness Removal.

BIG CAM III ENGINE REMOVAL (Contd)

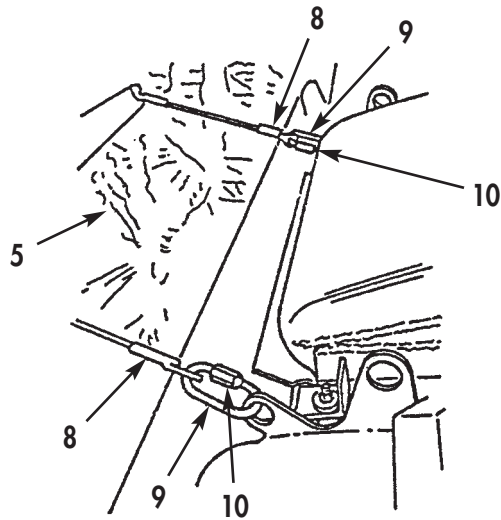


Figure 5. Tilt Assist Cables Removal.

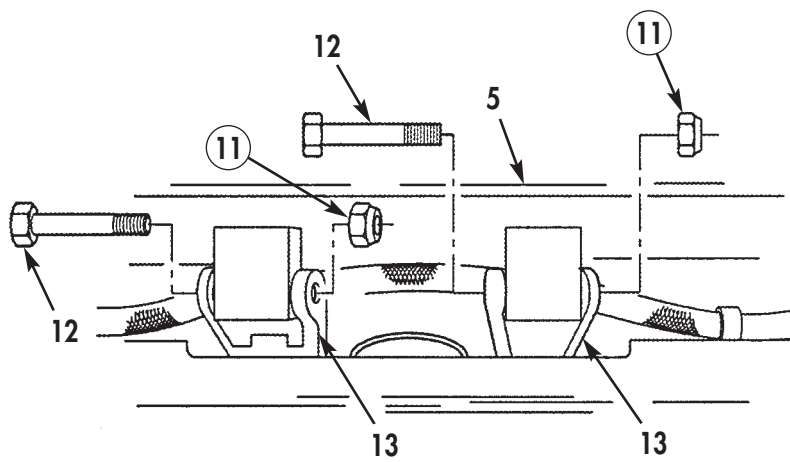


Figure 6. Hood Hinge Removal.

BIG CAM III ENGINE REMOVAL (Contd)

10. Release three air cleaner element clamps (1) and remove air cleaner element (2) from air cleaner housing (9). Discard air cleaner element (2).
11. Loosen three clamps (4) and remove air cleaner duct assembly (5) from turbocharger outlet (8) and air cleaner outlet elbow (3).
12. Remove vent tube screw (11), locknut (18), and washer (12) from air duct support bracket (17). Discard locknut (18).
13. Remove two air vent hose clamps (13), air vent hose (14), and air vent tube (10) from air duct support bracket (17).
14. Remove four air cleaner housing bracket locknuts (22), washers (21), and screws (20) from support brackets (17) and air cleaner housing (9). Discard locknuts (22).
15. Remove indicator tube (16) and elbow (15) from air cleaner housing (9).
16. Remove six air cleaner housing locknuts (31), washers (30), and air cleaner housing (9) from adapter duct (25). Discard locknuts (31).
17. Disconnect air duct door spring (32) from air duct door (29) and firewall (19).
18. Remove ten adapter duct locknuts (27), washers (26) and (24), screws (23), four reinforcement plates (28), and adapter duct (25) from air cleaner box (19). Discard locknuts (27).

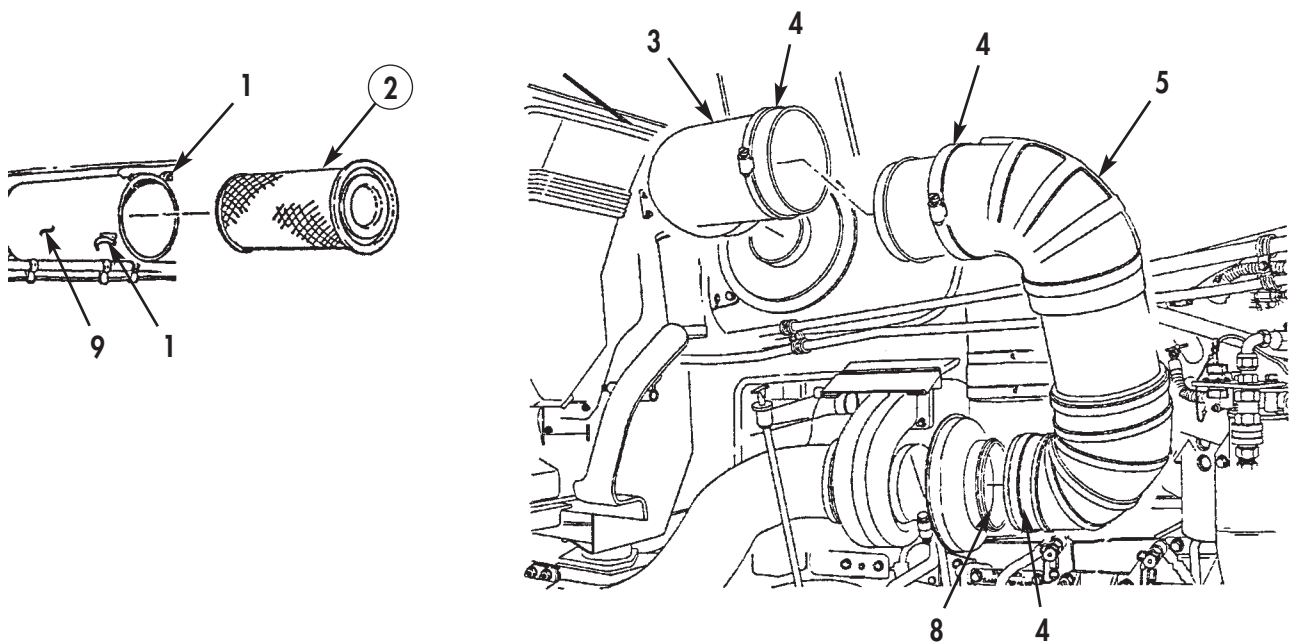


Figure 7. Air Cleaner Removal.

BIG CAM III ENGINE REMOVAL (Contd)

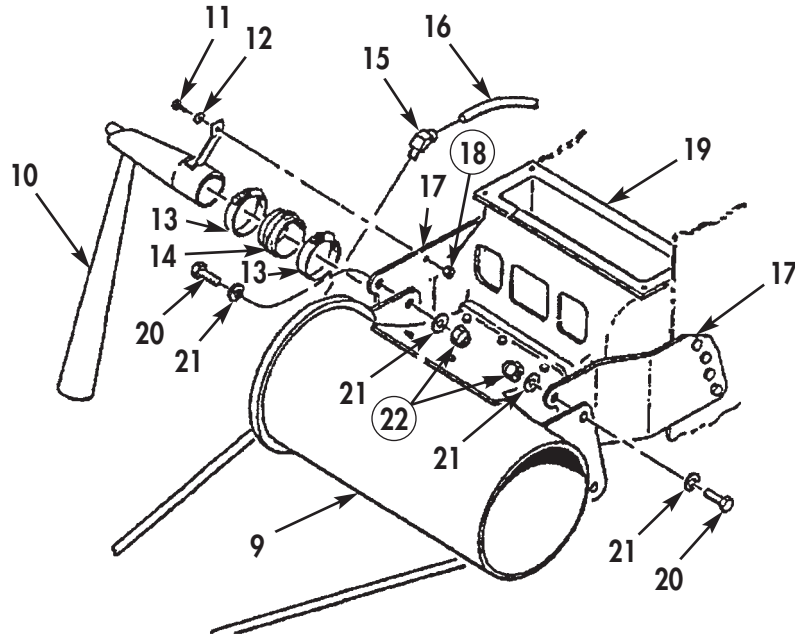


Figure 8. Air Duct Removal.

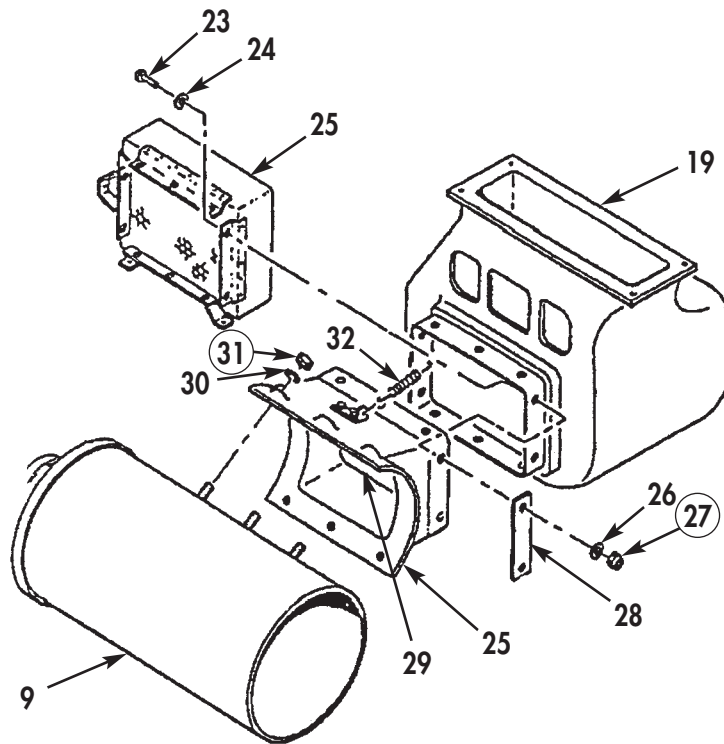


Figure 9. Air Cleaner Housing Removal.

BIG CAM III ENGINE REMOVAL (Contd)

19. Loosen exhaust S-pipe clamp (3) and remove from turbocharger outlet flange (4).
20. Loosen two exhaust pipe nuts (6), screws (2), and exhaust S-pipe clamp (1). Remove exhaust S-pipe (5) from exhaust pipe (7).
21. Loosen heater hose clamp (9) and remove heater hose (8) and heater hose clamp (9) from heater hose tube (10).
22. Loosen heater hose clamp (12) and remove heater hose (13) and heater hose clamp (12) from heater hose tube adapter (11).
23. Loosen two vent hose clamps (16) and remove vent hoses (17) and vent hose clamps (16) from radiator (15).
24. Loosen bypass hose clamp (18) and remove bypass hose (19) from radiator (15).
25. Loosen two lower radiator hose clamps (23) and remove lower radiator tube (28) and lower radiator hose clamps (23) from radiator (15).
26. Loosen three cooling outlet tube clamps (24) at water pump inlet (31) and cooling outlet tube (29).
27. Remove cooling outlet tube nut (26) and screw (27) from support bracket (25).
28. Remove cooling outlet tube (29) from water pump (30).
29. Loosen two upper radiator hose clamps (20) and remove upper radiator hose (22) and upper radiator hose clamps (20) from thermostat housing elbow (21) and radiator inlet tube (14).

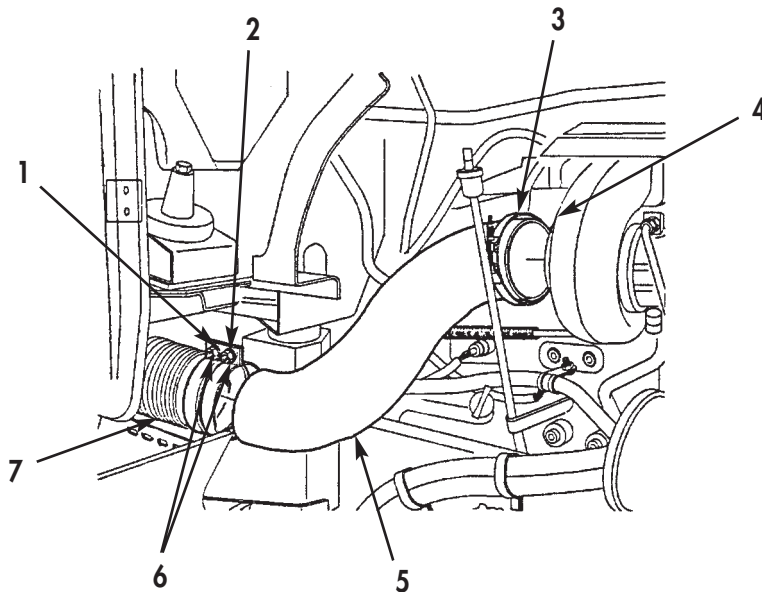


Figure 10. Turbocharger Hose Removal.

BIG CAM III ENGINE REMOVAL (Contd)

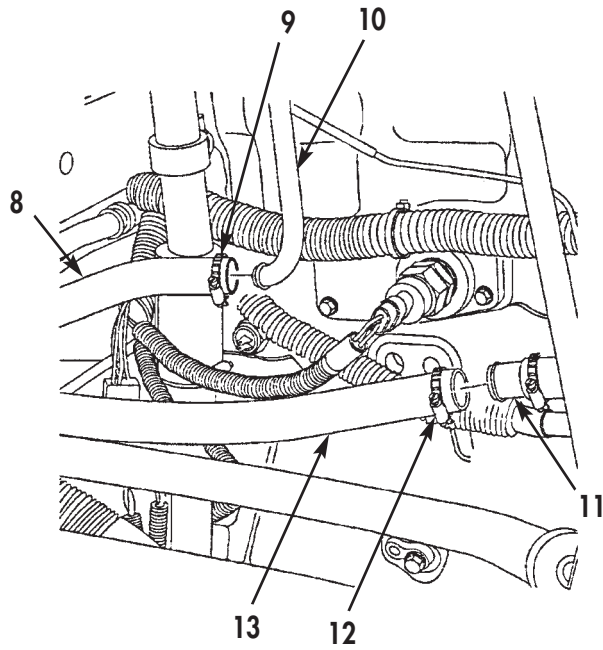


Figure 11. Heater Hose Removal.

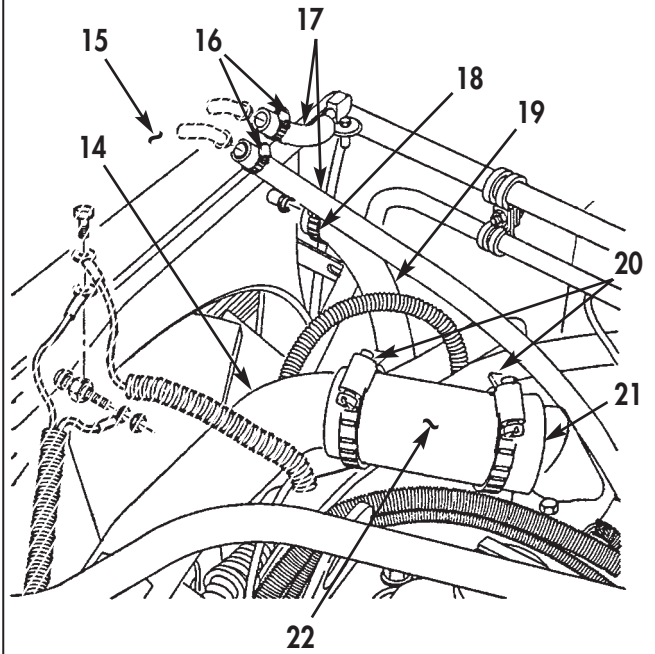


Figure 12. Upper Radiator Hose Removal.

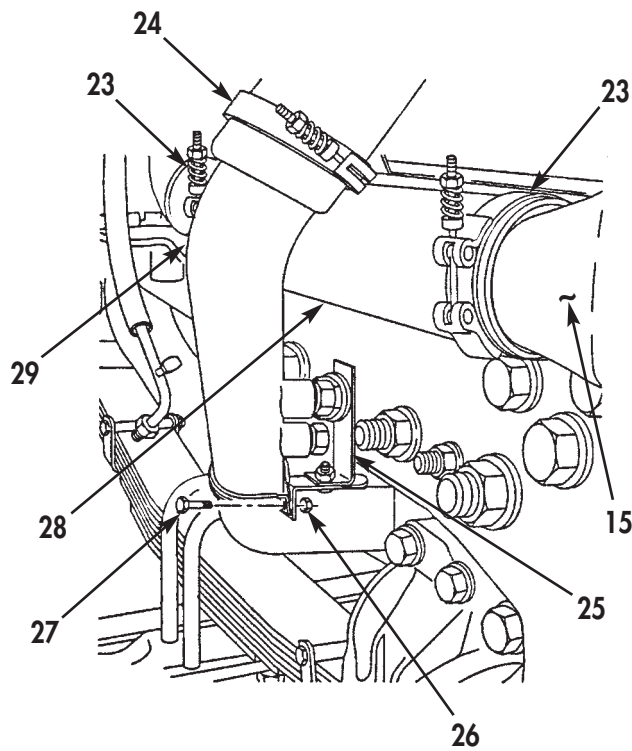


Figure 13. Lower Radiator Tube Removal.

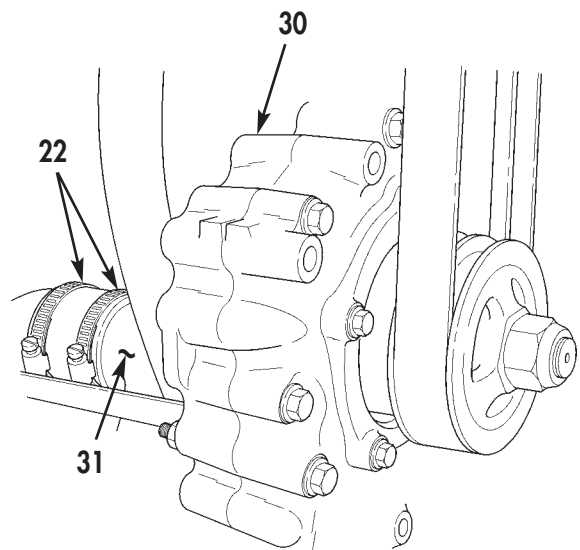


Figure 14. Water Pump and Water Pump Inlet.

BIG CAM III ENGINE REMOVAL (Contd)

30. Disconnect A/C compressor clutch electrical connector (7) from engine wiring harness (6).
31. Loosen two A/C compressor mounting bracket locknuts (23), bolts (26), and washers (24).
32. Loosen two jam nuts (11) on A/C compressor adjusting rod (15).
33. Push A/C compressor (5) in towards engine (20). Remove A/C drive belt (19) from A/C clutch pulley (25) and accessory drive pulley (17).
34. Remove A/C compressor adjusting rod locknut (12), two washers (13), bolt (18), and A/C compressor adjusting rod (15) from front cover (16). Discard locknut (12).
35. Remove A/C compressor hose locknut (21) washer (22), screw (2), and clamp (1) from top of engine (20). Discard A/C compressor hose locknut (21).
36. Remove two A/C compressor line screws (9), washers (10), and clamps (8) and (14) from A/C compressor (5).
37. Remove two A/C compressor mounting bracket locknuts (23), bolts (26), and washers (24) from A/C compressor mounting bracket (27). Discard A/C compressor mounting bracket locknuts (23).

NOTE

Do not disconnect A/C lines or hoses. A/C compressor can be removed and positioned on passenger side of vehicle for engine removal with A/C lines and hoses attached.

38. Remove A/C compressor (5) with A/C compressor lines (3) and A/C compressor hoses (4) and position A/C compressor (5) aside.

BIG CAM III ENGINE REMOVAL (Contd)

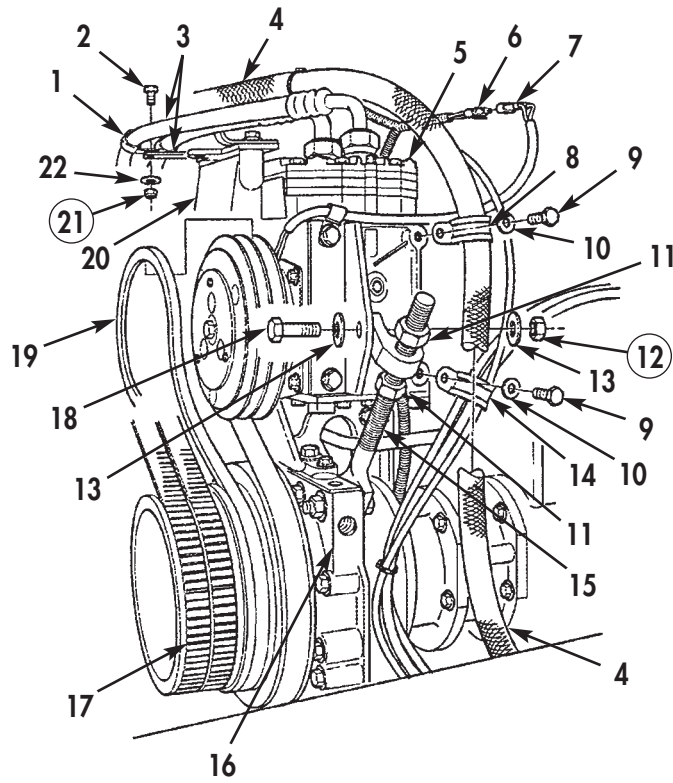


Figure 15. A/C Compressor Mounting Bracket Removal.

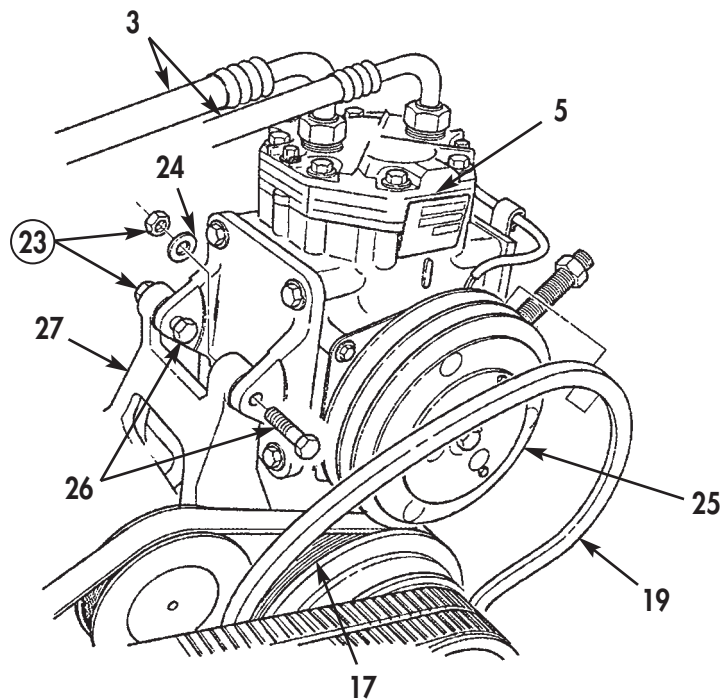


Figure 16. A/C Compressor Mounting Bolts Removal.

BIG CAM III ENGINE REMOVAL (Contd)**NOTE**

Do not disconnect A/C lines or hoses from A/C condenser. A/C condenser can be removed from radiator and positioned on outside of passenger side frame rail for engine removal.

39. Remove three A/C condenser line locknuts (6), washers (7), screws (1), and clamps (8) from radiator support brackets (9). Discard locknuts (6).
40. Remove four A/C condenser locknuts (2) and A/C condenser (4) with A/C compressor lines (5) attached, from two support brackets (3) on front of radiator (10). Discard locknuts (2).
41. Remove coolant temperature sender terminal nut (12) and coolant temperature sender electrical connector (13) from coolant temperature sender terminal (14).
42. Remove coolant temperature sender terminal screw (11) and coolant temperature sender electrical connectors (15) from coolant temperature sender terminals (14) on radiator (10).

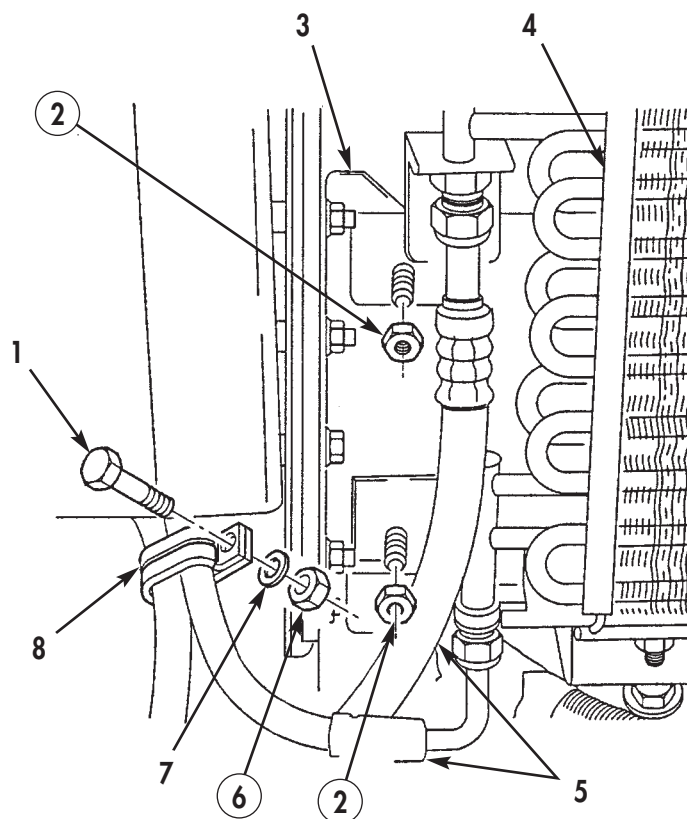


Figure 17. A/C Condenser Hoses Removal.

BIG CAM III ENGINE REMOVAL (Contd)

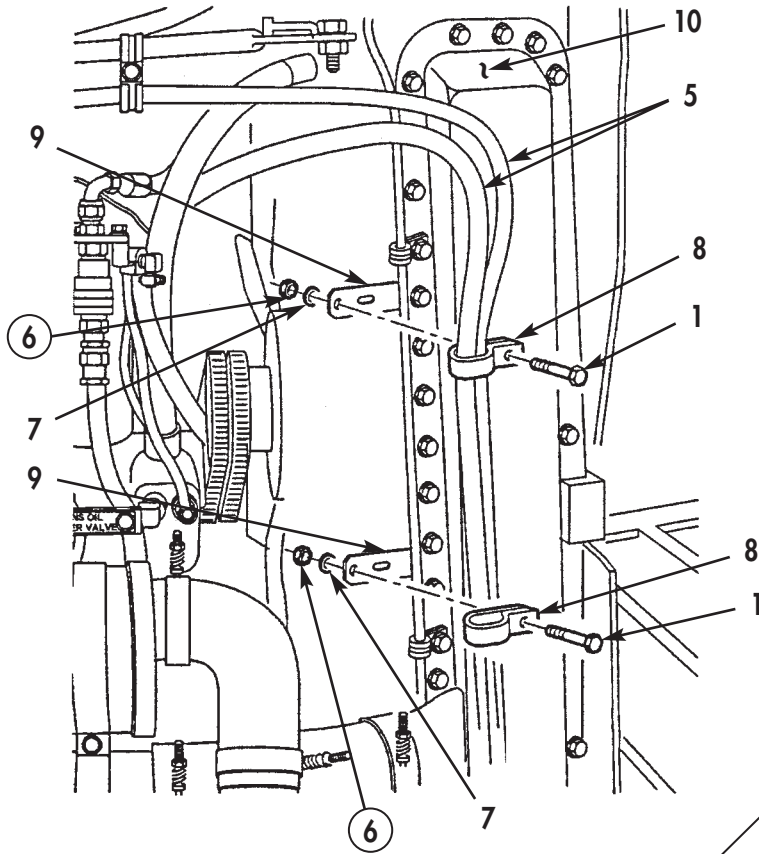


Figure 18. A/C Condenser Lines Removal.

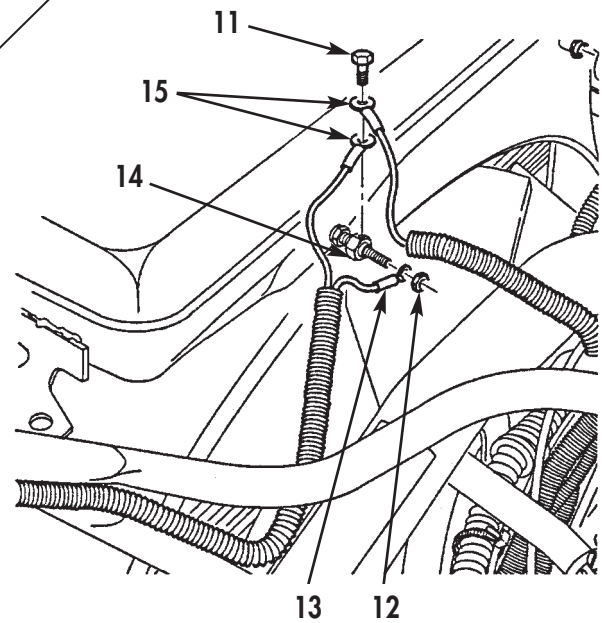


Figure 19. Temperature Sender Electrical Connectors Removal.

BIG CAM III ENGINE REMOVAL (Contd)

43. Attach chains and lifting device on radiator (1).
44. Remove two ground strap locknuts (3), washers (2), isolators (5), and ground strap (4) from radiator (1) and frame front crossmember (15). Discard locknuts (3).
45. Remove four radiator support rod locknuts (10), eight washers (8), four spacers (7), four screws (9), and three radiator support rods (11) from radiator (1) and firewall brackets (6). Discard locknuts (10).
46. Remove two radiator crossmember mount locknuts (14), washers (12), and isolators (13) from crossmember (15). Discard locknuts (14).
47. Using lifting device and chains, remove radiator (1) from front crossmember (15) and lower radiator (1) to floor.
48. Remove lifting device, chains, two isolators (13), and washers (12) from radiator (1).

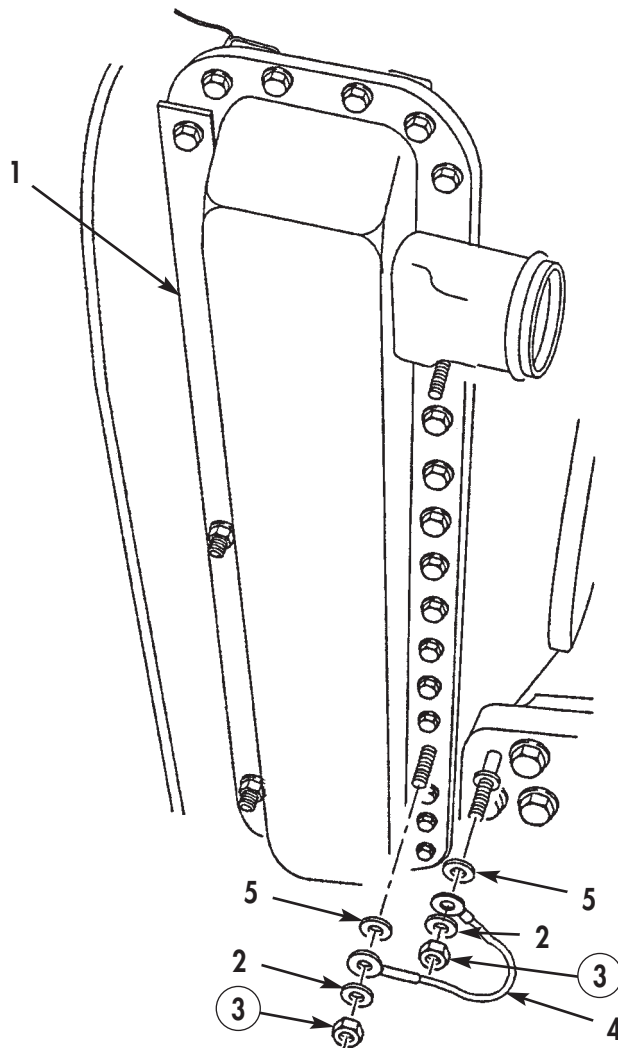


Figure 20. Radiator Ground Strap Removal.

BIG CAM III ENGINE REMOVAL (Contd)

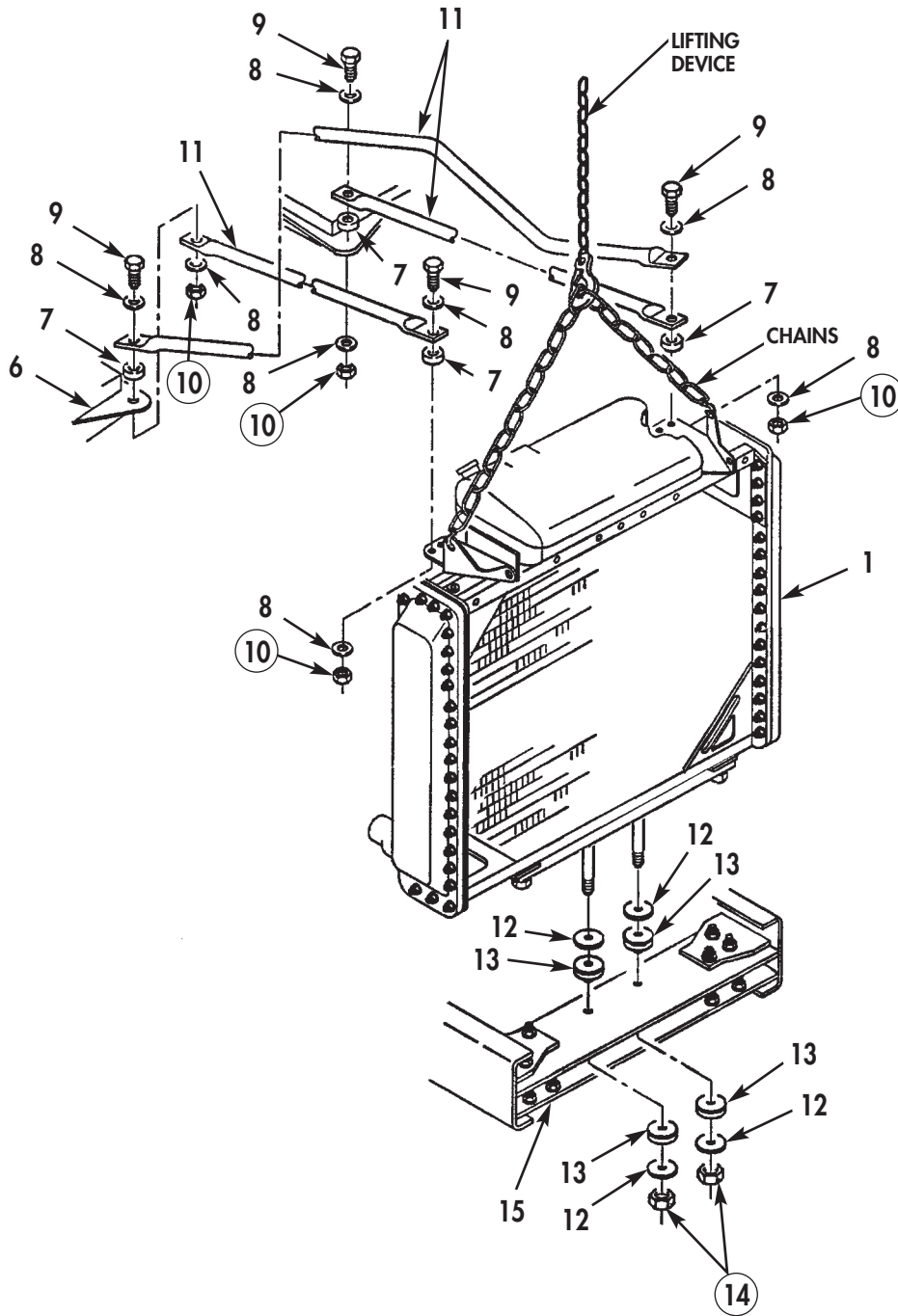


Figure 21. Radiator Removal.

BIG CAM III ENGINE REMOVAL (Contd)

49. Remove six cooling fan nuts (1), lockwashers (2), washers (3), and cooling fan (4) from cooling fan clutch studs (5). Discard lockwashers (2).
50. Position container under power steering reservoir (8), remove drain plug (9) and drain power steering fluid. Install drain plug (9).

NOTE

Cap and plug all openings, hoses, and lines to prevent fluid contamination.

51. Loosen two power steering hose clamps (7) and remove power steering hoses (6) and clamps (7) from power steering reservoir (8) and power steering pump (12).
52. Remove power steering hose (11) from elbow (10) on power steering reservoir (8).
53. Remove fuel return line (20) from fuel return line T-fitting (19) on engine (16).
54. Remove fuel supply line (24) from fuel filter fitting (25).
55. Remove retaining pin (15) and transmission modulator cable (23) from throttle lever (27).
56. Remove two throttle position sensor cable clamp locknuts (26), screws (18), four washers (21), clamp (17), and transmission modulator cable (23) from mounting bracket (22). Discard locknuts (26).
57. Remove two accelerator return springs (31), accelerator rod locknut (32), screw (30), and accelerator rod (28) from lower throttle lever (29). Discard locknut (32).
58. Remove tachometer cable (14) from fuel pump tachometer drive (13).

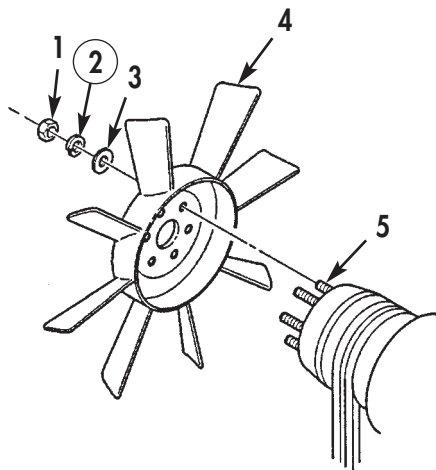


Figure 22. Cooling Fan Removal.

BIG CAM III ENGINE REMOVAL (Contd)

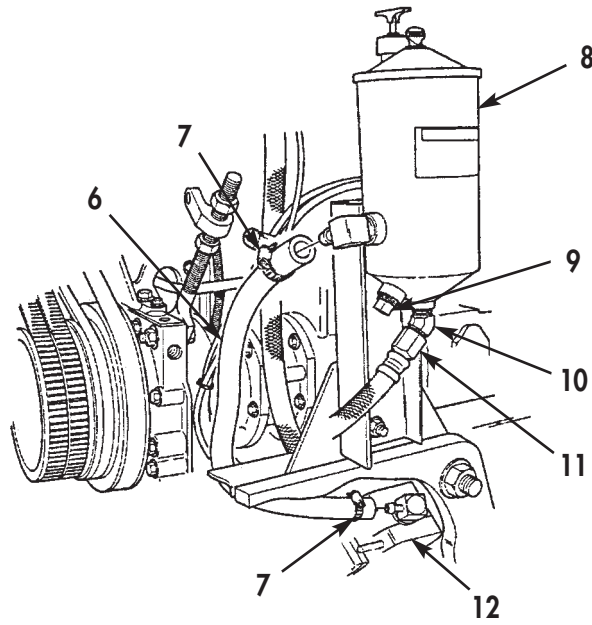


Figure 23. Power Steering Hoses Removal.

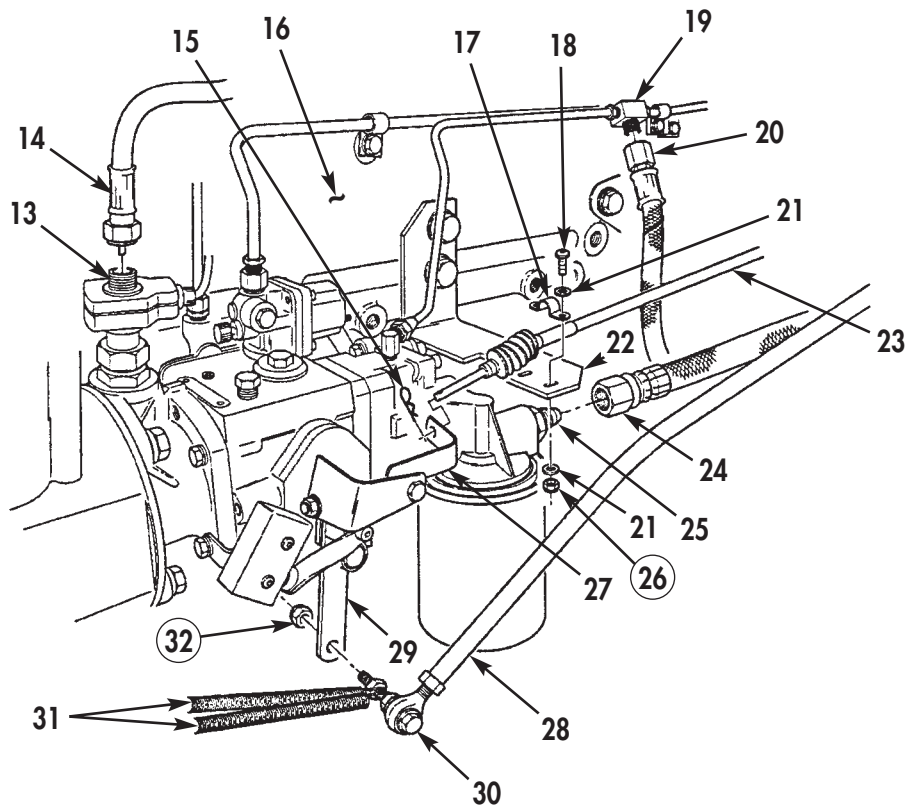


Figure 24. Throttle Lever Removal.

BIG CAM III ENGINE REMOVAL (Contd)

59. Disconnect air compressor hose (1) at top of transmission (2).
60. Disconnect oil sample hose (3) from elbow fitting (4) on oil filter housing (5).
61. Disconnect two air lines (6) from air compressor (7).
62. Disconnect air line (9) from fan temperature switch (8).
63. Disconnect two transmission oil cooler hoses (10) and (11) from transmission (2).
64. Remove transmission oil cooler hose nut (13), washer (12), screw (15), clamp (16), and transmission oil cooler hoses (10) and (11) from transmission oil cooler base mounting bracket (14).

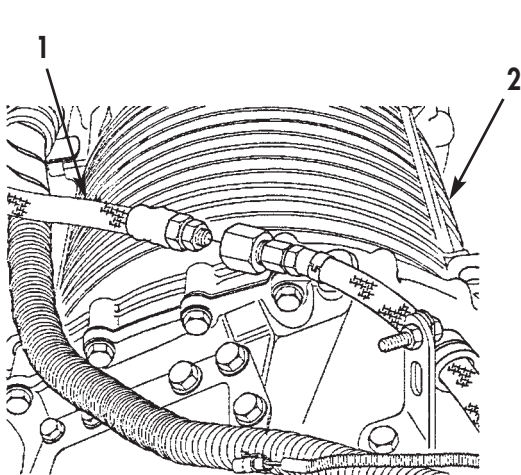


Figure 25. Air Compressor Hose Removal.

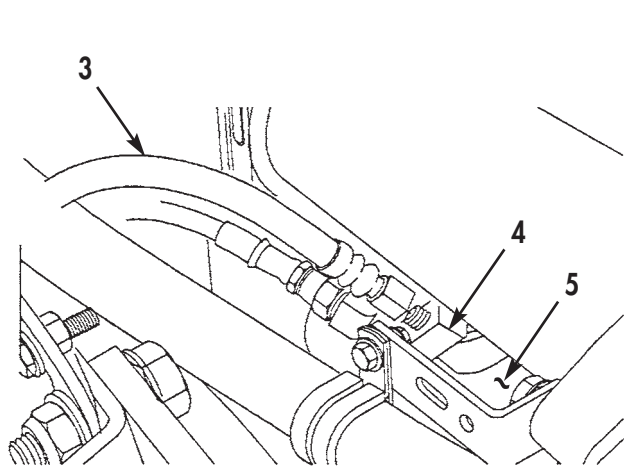


Figure 26. Engine Oil Sampling Hose Removal.

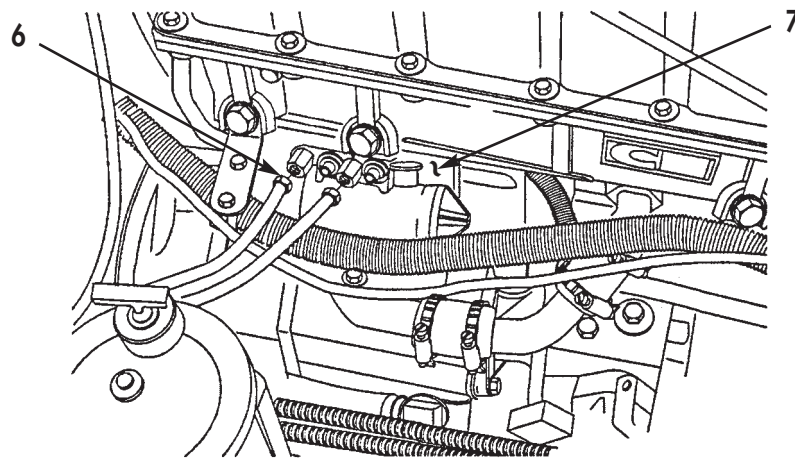


Figure 27. Air Compressor Lines Removal.

BIG CAM III ENGINE REMOVAL (Contd)

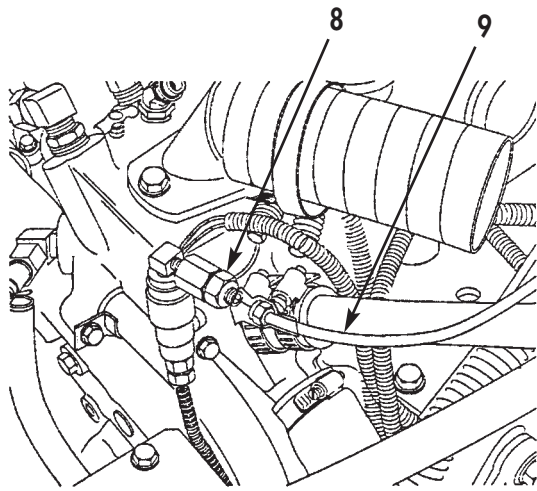


Figure 28. Fan Temperature Switch Removal.

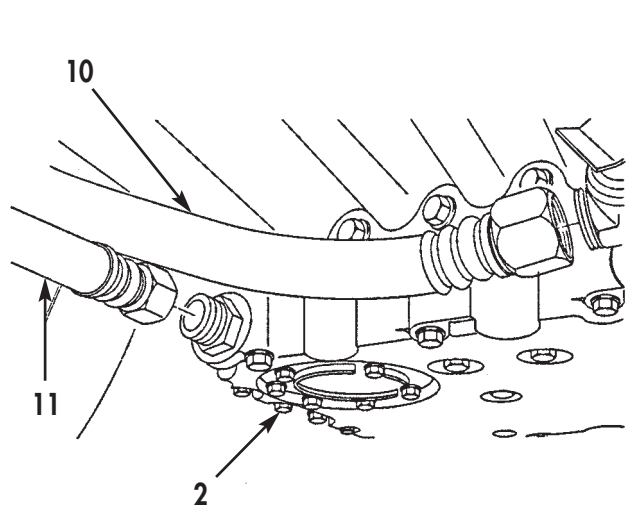


Figure 29. Transmission Oil Cooler Hoses Removal.

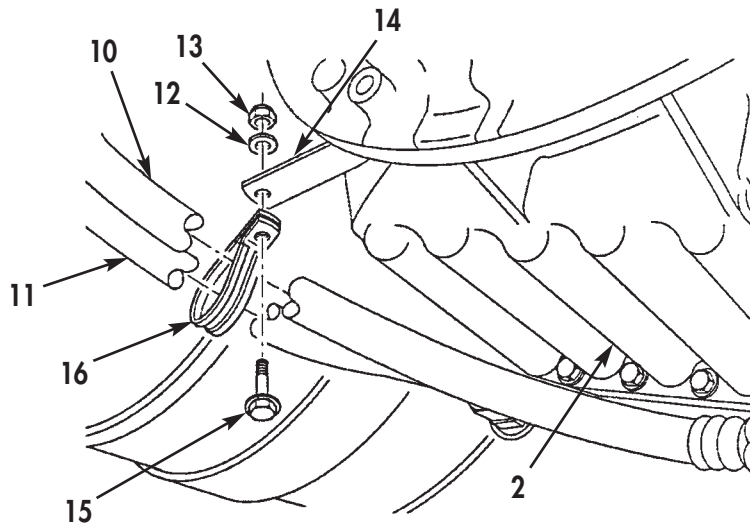
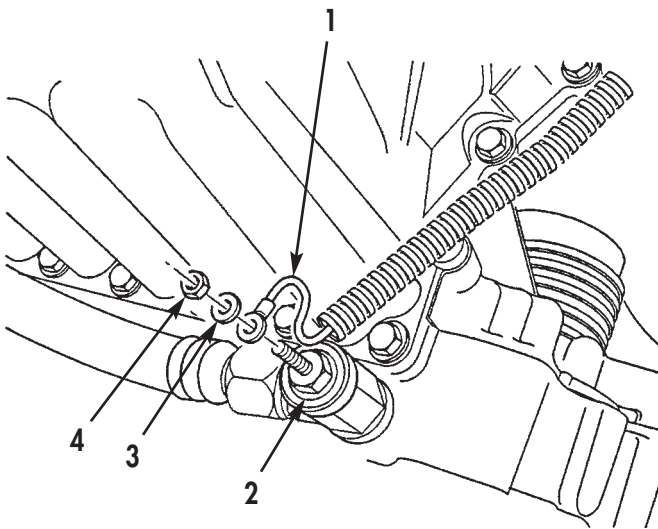


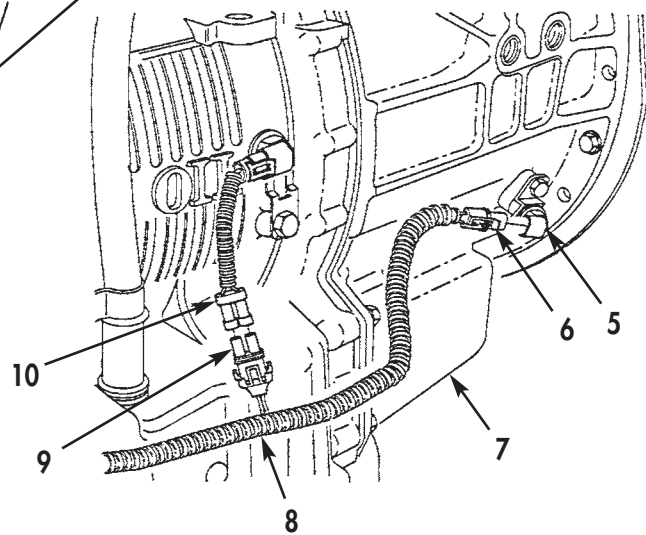
Figure 30. Transmission Oil Cooler Hose Clamp Removal.

BIG CAM III ENGINE REMOVAL (Contd)

65. Remove transmission oil temperature sensor electrical connector nut (4), washer (3), and transmission oil temperature sensor electrical connector (1) from transmission oil temperature sensor (2).
66. Disconnect engine speed sensor electrical connector (6) from engine speed sensor (5) on transmission (7).
67. Disconnect turbine speed sensor electrical connector (9) from turbine speed sensor jumper harness (10) on transmission (7).
68. Disconnect output speed sensor electrical connector (11) from output speed sensor (12) on transmission (7).
69. Remove transmission electrical harness nut (17), screw (14), clamp (13), two washers (15), and transmission electrical harness (8) from transmission (7).
70. Disconnect control valve module electrical harness (16) from transmission electrical harness (8).



*Figure 31.
Transmission Oil Temperature
Sensor Removal.*



*Figure 32.
Engine Speed and Turbine Sensor Removal.*

BIG CAM III ENGINE REMOVAL (Contd)

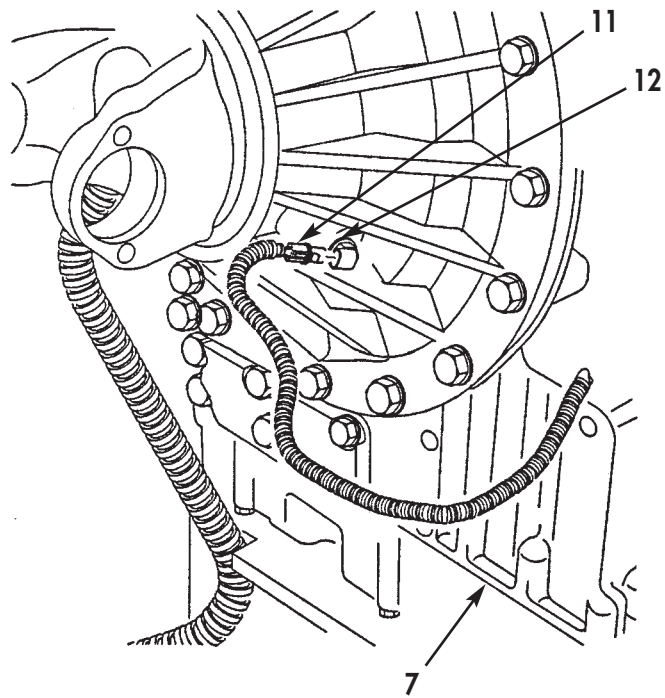


Figure 33. Output Speed Sensor Removal.

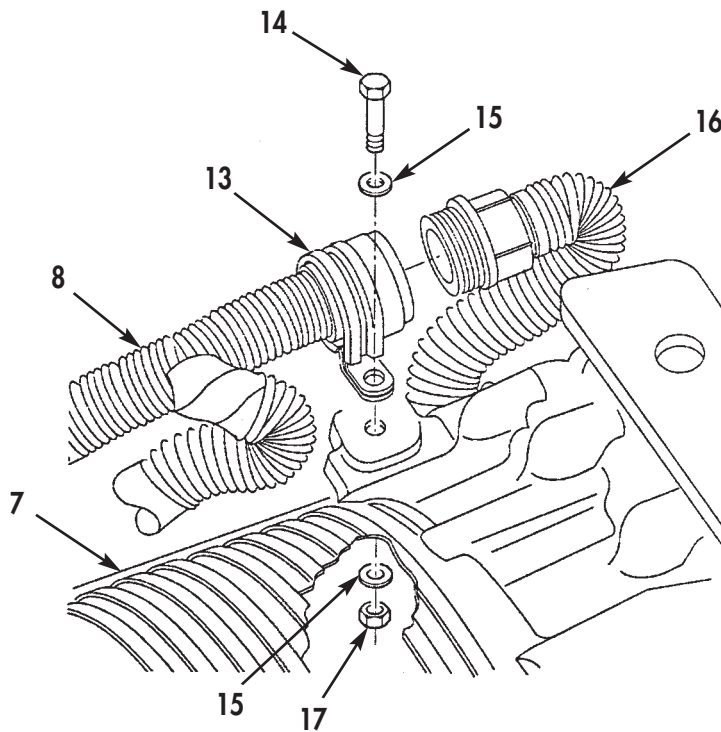


Figure 34. Transmission Electrical Harness Removal.

BIG CAM III ENGINE REMOVAL (Contd)

71. Loosen two alternator mounting bracket screws (3).
72. Loosen two alternator jam nuts (1) on alternator adjusting rod (6).
73. Push alternator (5) in towards engine (2) and remove two drive belts (4).
74. Remove alternator terminal nut (19), washer (18), and engine electrical harness positive lead (15) from alternator positive terminal (17).
75. Remove alternator terminal nut (7), washer (8), and engine electrical harness negative lead (9) from alternator negative terminal (16).
76. Remove alternator terminal nut (10), washer (11), and engine electrical harness transformer/rectifier positive lead (14) from alternator transformer/rectifier positive terminal (21).
77. Remove alternator terminal nut (12), washer (13), and engine electrical harness transformer/rectifier negative lead (22) from alternator transformer/rectifier negative terminal (20).

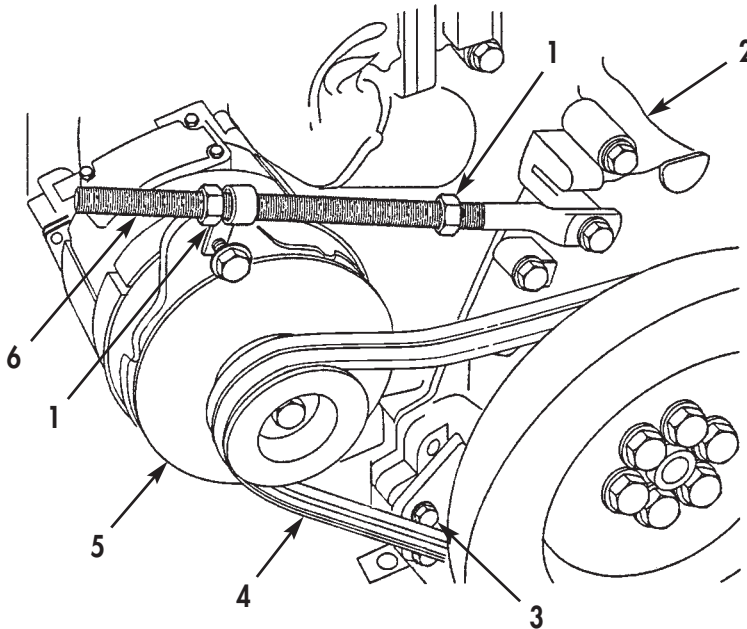


Figure 35. Alternator Belt Removal.

BIG CAM III ENGINE REMOVAL (Contd)

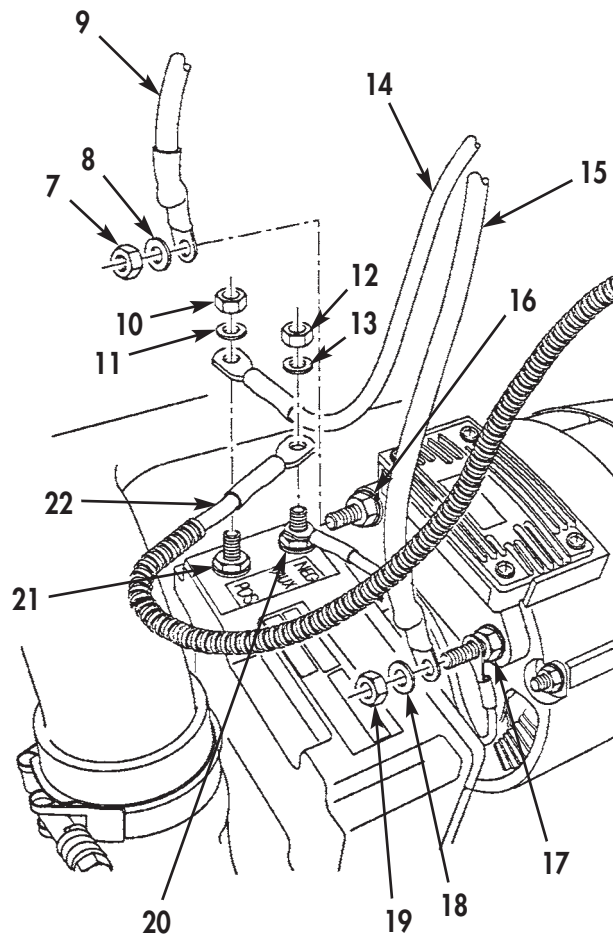


Figure 36. Alternator Electrical Connections Removal.

BIG CAM III ENGINE REMOVAL (Contd)

78. Disconnect temperature sensor electrical connector (1) from temperature sensor (11).
79. Remove fan temperature switch screw (4), washer (5), pressure harness lead (6), and solenoid lead (8) from fan temperature switch (10), terminal A.
80. Remove fan temperature switch screw (3), washer (2), pressure harness lead (9), and engine harness lead (7) from fan temperature switch (10), terminal B.
81. Remove 12V power stud grommet (12), nut (15), washer (14), two engine harness leads (16) and (17), and 12V power lead (18) from 12V power stud (13).

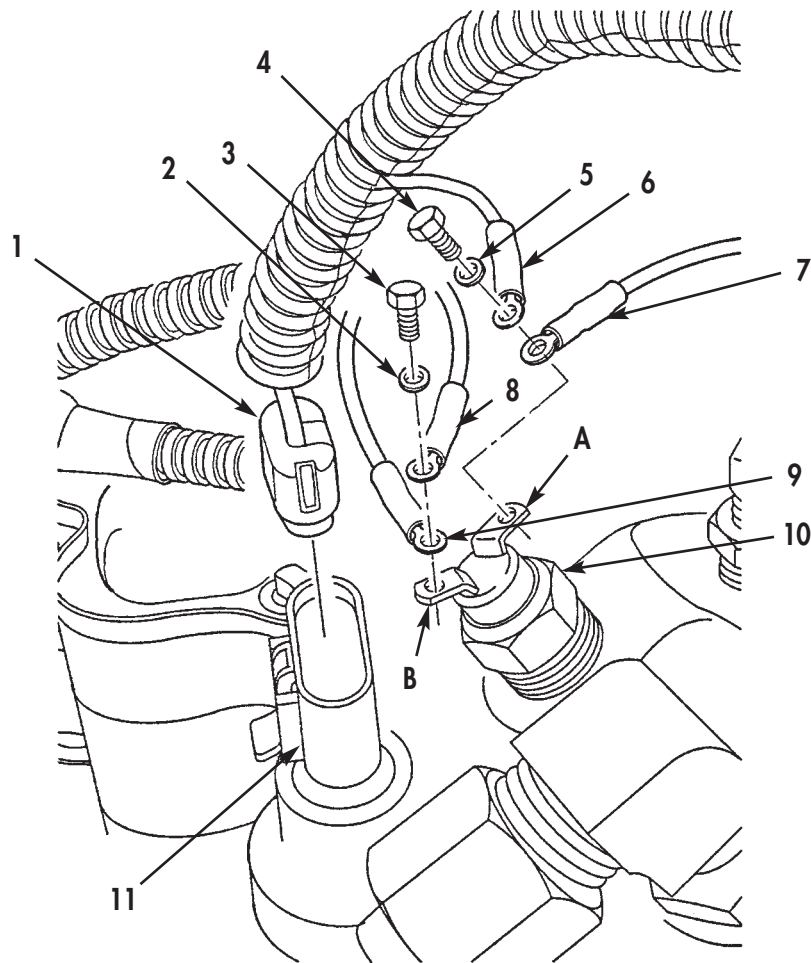


Figure 37. Fan Temperature Switch Electrical Connections.

BIG CAM III ENGINE REMOVAL (Contd)

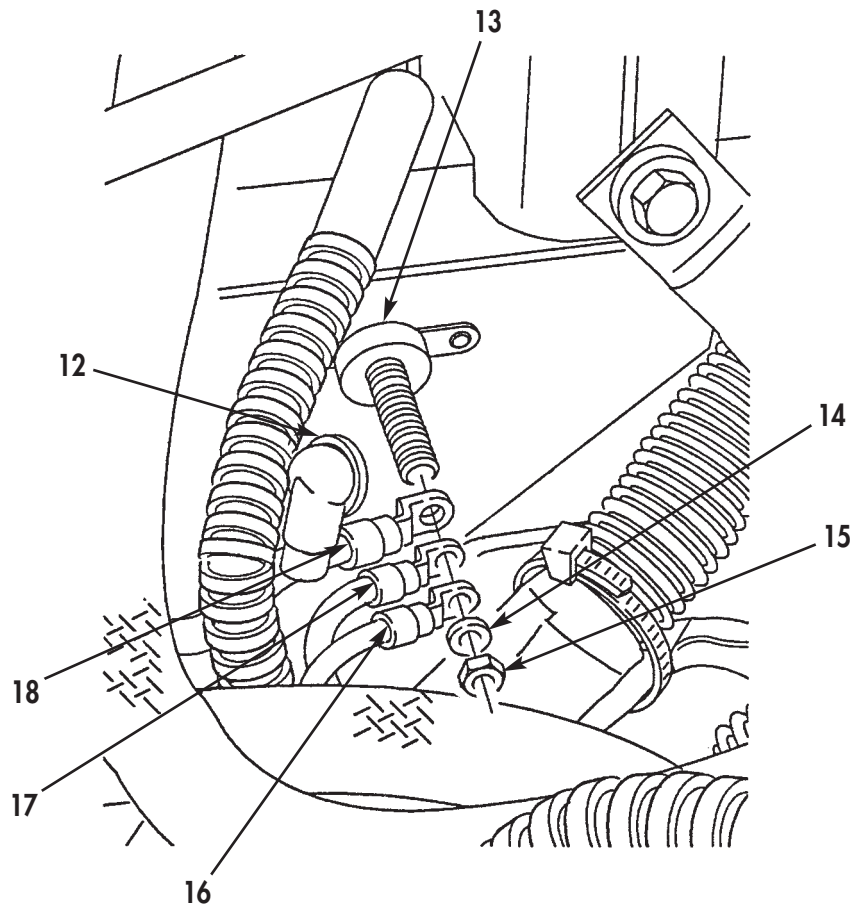


Figure 38. 12V Harness Leads Removal.

BIG CAM III ENGINE REMOVAL (Contd)

82. Remove starter S-terminal nut (15), lockwasher (16), and starter electrical harness lead no. 74 (17) from starter S-terminal (18). Discard lockwasher (16).
83. Remove starter positive terminal nut (4), lockwasher (6), battery positive cable (5), and three starter electrical harness leads no. 202 (7), no. 82 (8), and no. 421 (9) from starter positive terminal (19). Discard lockwasher (6).
84. Remove starter ground terminal nut (1), lockwasher (2), battery ground cable (22), ground jumper cable (3), and starter electrical harness lead no. 83 (21) from starter ground terminal (20). Discard lockwasher (2).
85. Remove A/C electrical harness ground lead screw (13), two starwashers (11) and (12), A/C electrical harness ground lead (10), and ground jumper cable (3) from engine (14). Discard starwashers (11).
86. Remove fuel solenoid terminal nut (25), lockwasher (24), and fuel solenoid electrical harness lead (26) from fuel solenoid (23). Discard lockwasher (24).
87. Disconnect fuel pump pressure sensor electrical connector (28) from fuel pump pressure sensor (27).

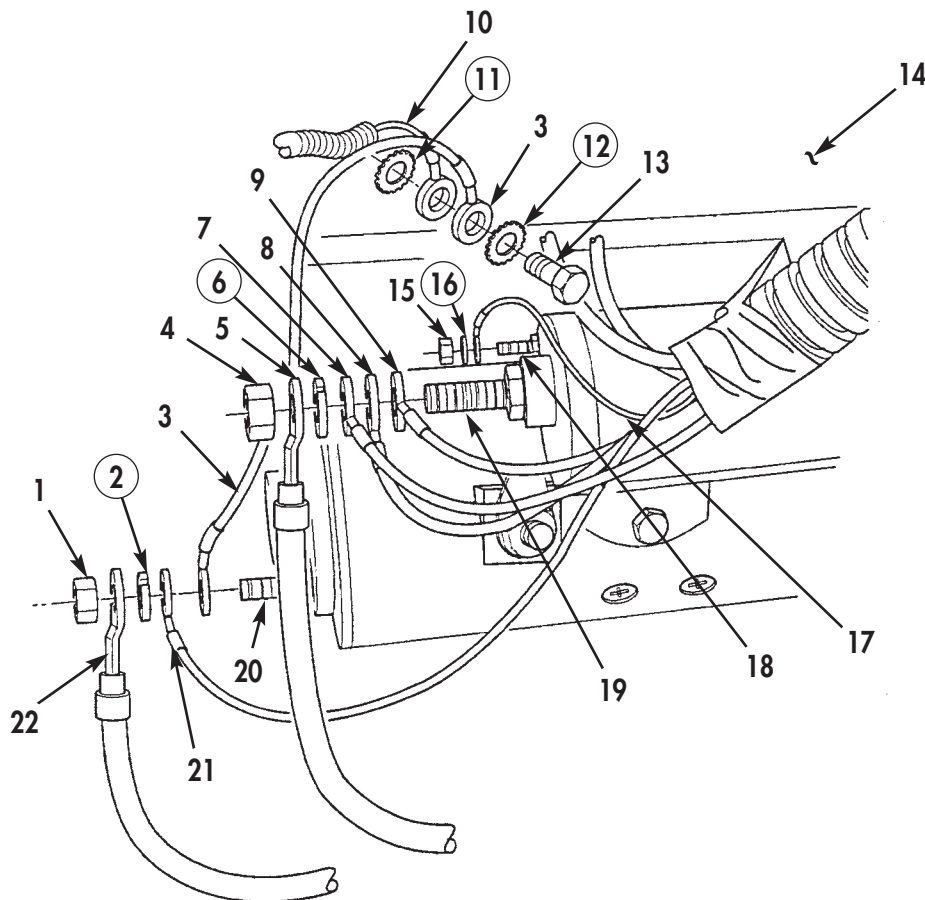


Figure 39. Starter Motor Electrical Connections Removal.

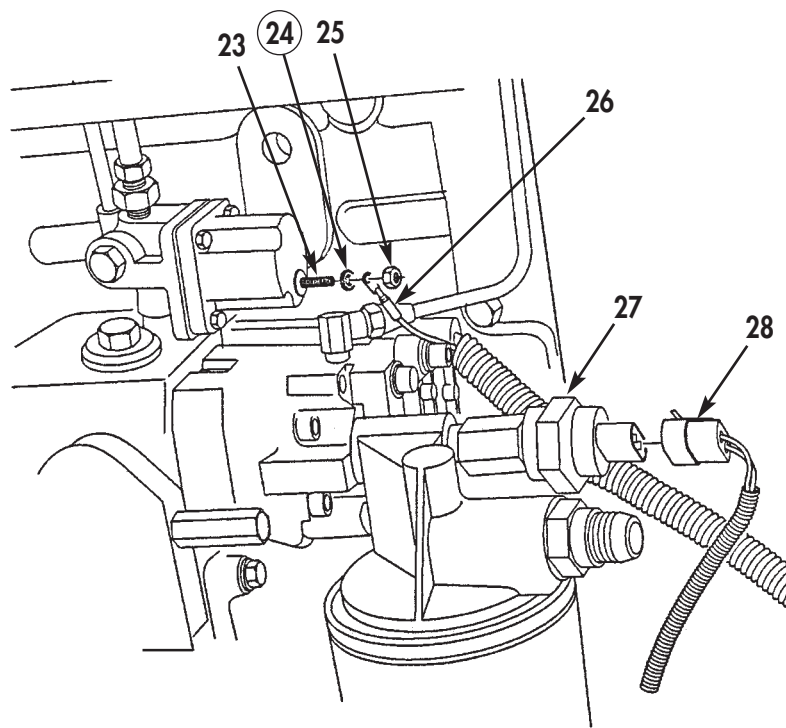
BIG CAM III ENGINE REMOVAL (Contd)

Figure 40. Solenoid and Pressure Sensor Wiring Removal.

BIG CAM III ENGINE REMOVAL (Contd)

88. Disconnect jacob brake electrical connector (1) from engine harness connector (2).
89. Disconnect front (4), middle (5), and rear (6) jacob brake electrical connectors from cylinder heads (3).
90. Disconnect transmission TPS harness electrical connector (8) from vehicle TPS harness electrical connector (7).

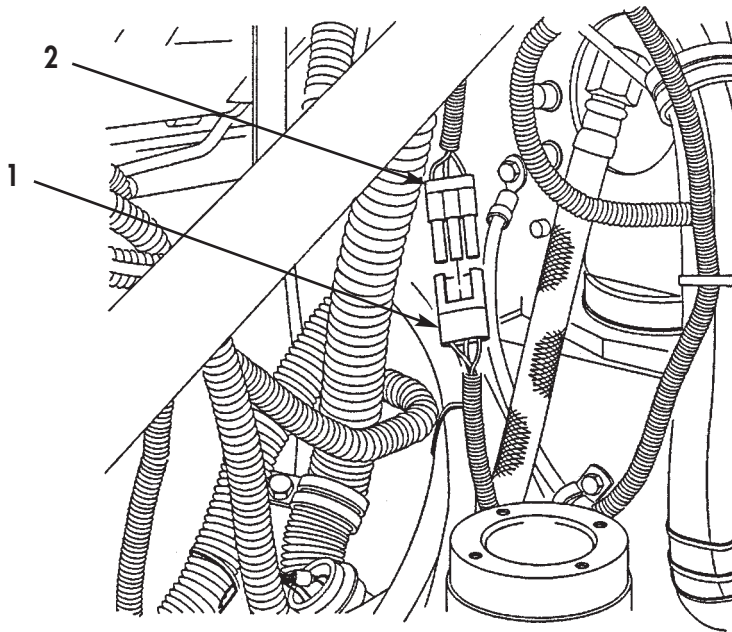


Figure 41. Jacob Brake Harness Removal.

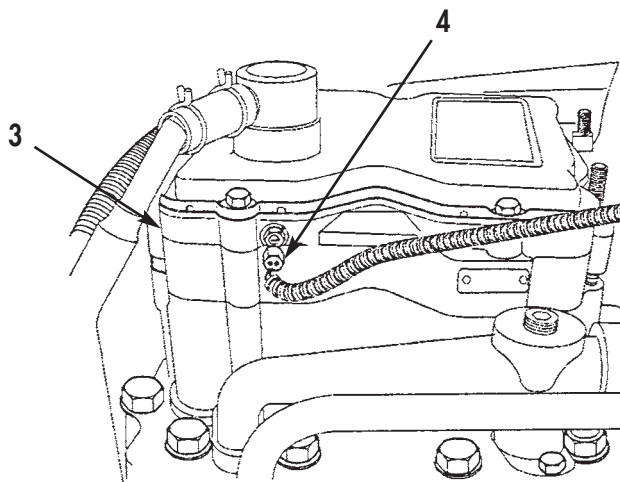


Figure 42. Front Jacob Brake Electrical Connector.

BIG CAM III ENGINE REMOVAL (Contd)

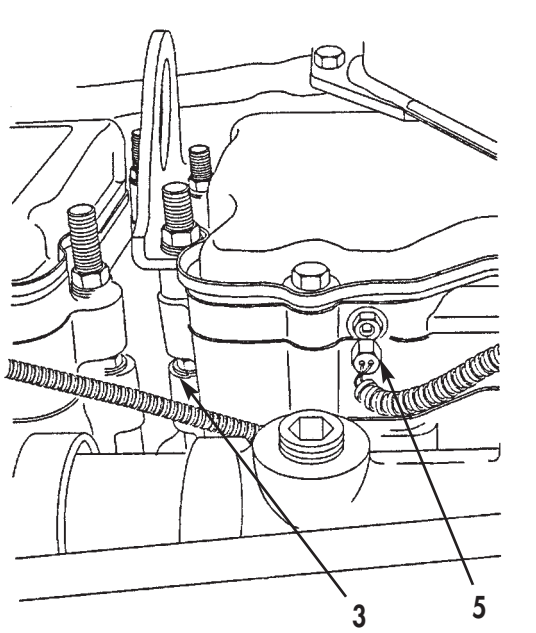


Figure 43.
Middle Jacob Brake Electrical Connector.

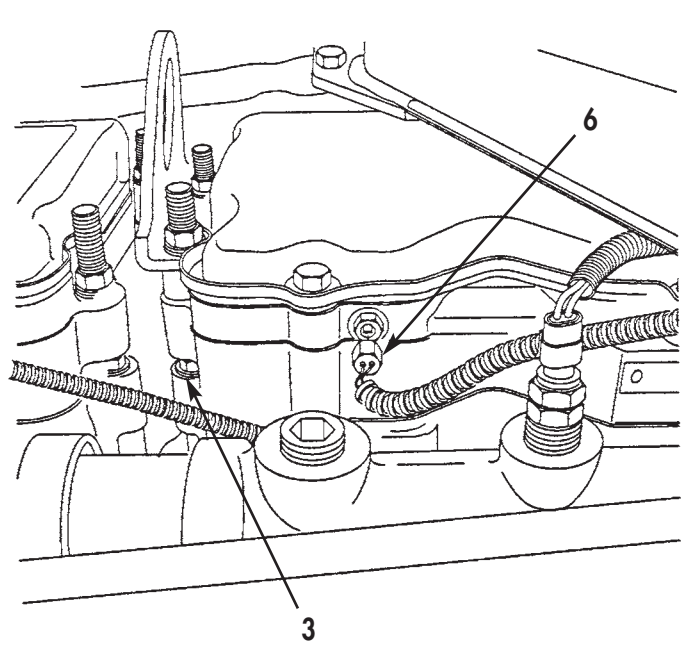


Figure 44. *Rear Jacob Brake Electrical Connector.*

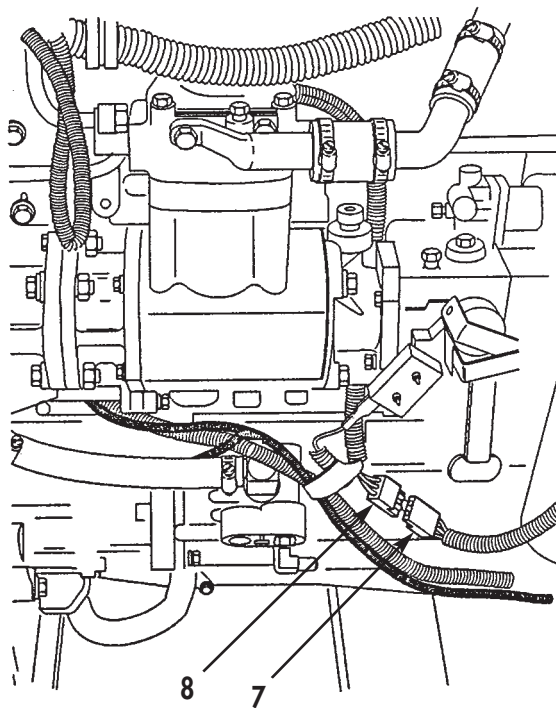


Figure 45. *Transmission Harness Electrical Connector.*

BIG CAM III ENGINE REMOVAL (Contd)

91. Disconnect ether quick-start tube (3) from atomizer (4) on intake manifold (1).
92. Position and secure suitable transmission jack under transmission (11). Ensure transmission weight is supported by transmission jack.
93. Remove flywheel bolt access cover screw (5) from P-clamp (6) and flywheel housing (13) and position P-clamp (6) away from flywheel housing (13).
94. Remove flywheel bolt access cover screws (5) and flywheel bolt access cover (7) from flywheel housing (13).

NOTE

Rotate engine using accessory drive pulley nut to gain access to flywheel bolts.

95. Remove twelve flywheel bolts (8) and washers (9) from flywheel (10) and torque converter (12).
96. Remove twelve transmission bolts (25) from transmission (11) and flywheel housing (13).
97. Attach tilt sling and lifting device to engine lifting brackets (2).
98. Remove two front engine crossmember mount nuts (23), four washers (19), two insulators (20), and bolts (22) from front engine crossmember mount (21).
99. Remove four mounting bracket nuts (26), insulators (28), eight washers (27), and four bolts (15) from mounting brackets (16).

WARNING

Use extreme care when handling heavy parts. Provide adequate support and use assistance during procedure. Ensure that any lifting device used is in good operating condition and of suitable load capacity. Keep clear of heavy components supported only by lifting device. Failure to do so may result in death or injury to personnel.

Use pry bars to free engine hangups or snags. Do not use hands. Failure to do so may result in damage to equipment or death or injury to personnel.

100. Using lifting device and lifting sling, remove engine (17) from frame (14). Ensure there is proper clearance between frame (14), alternator (24), engine (17), and power steering pump (18).
101. To mount engine on maintenance stand refer to WP 0009 00.

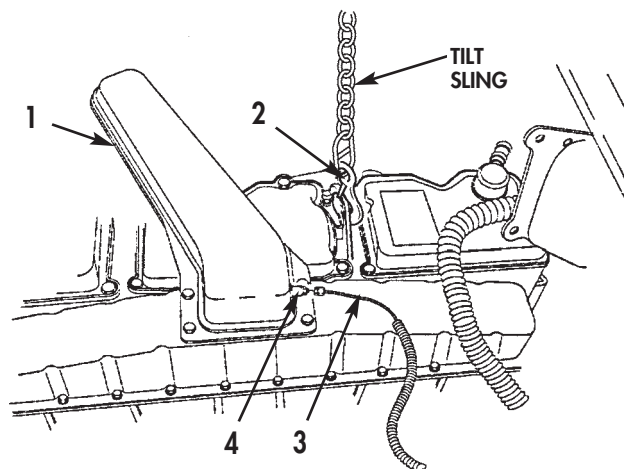


Figure 46. Ether Quick Start Tube.

BIG CAM III ENGINE REMOVAL (Contd)

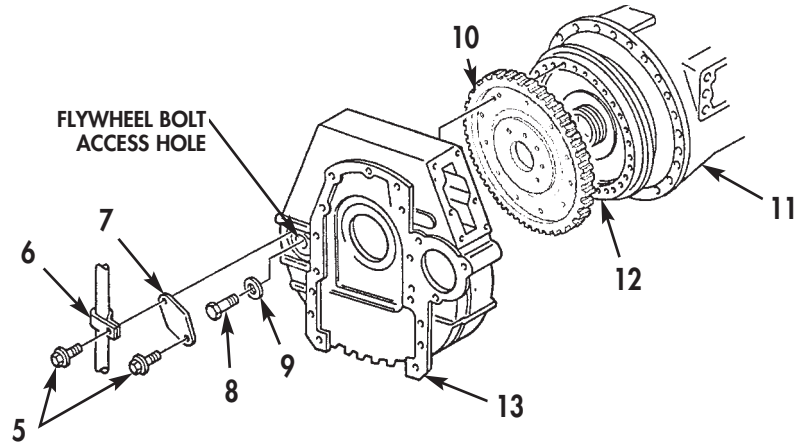


Figure 47. Disconnect Flywheel from Torque Converter.

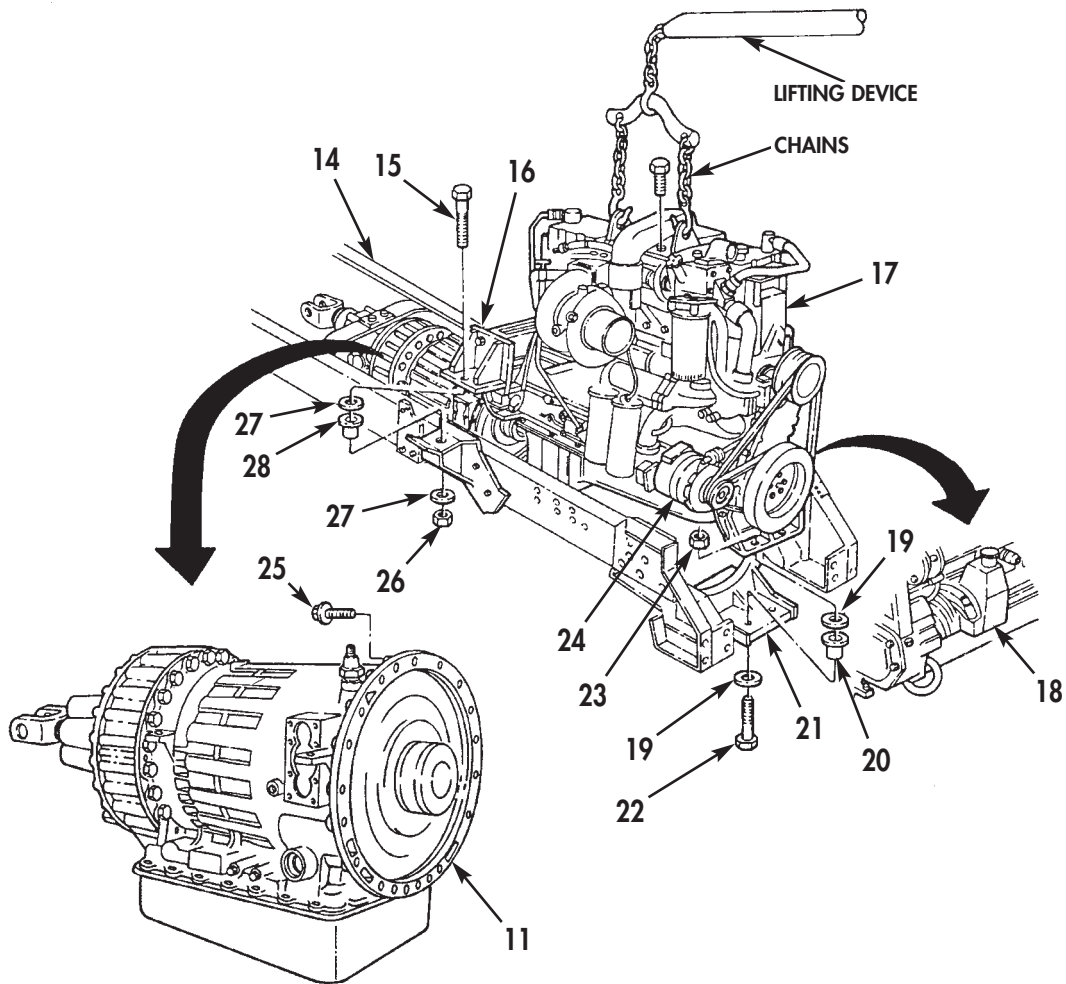


Figure 48. Engine Removal from Frame.

END OF WORK PACKAGE

**DIRECT SUPPORT AND GENERAL SUPPORT
MAINTENANCE MANUAL
INCLUDING REPAIR PARTS AND SPECIAL TOOLS LIST (RPSTL)**

FOR

M915, M915A1, M915A4, M916, M920 VEHICLES

NSN 2815-01-082-8125	P/N NTC400-3652-02	CUMMINS NTC-400 BIG CAM I DIESEL ENGINE W/CONTAINER
NSN 2815-01-142-2745	P/N 11669835	CUMMINS NTC-400 BIG CAM III DIESEL ENGINE W/CONTAINER

MOUNTING ENGINE ON MAINTENANCE STAND

INITIAL SETUP:

Tools and Special Tools

General mechanic's tool kit: automotive
(Item 1, WP 0061 00)
Maintenance and repair shop equipment:
automotive (Item 2, WP 0061 00)
Automotive maintenance and repair
supplemental set no. 2 (Item 3, WP 0061 00)
Maintenance stand
Lifting device
Chains

Equipment Condition

Engine removed from vehicle
(WP 0007 00 or WP 0008 00).

Personnel Required

Assistant

Materials/Parts

Four screws

MOUNTING ENGINE ON MAINTENANCE STAND (Contd)

1. Remove oil pressure gauge sensing unit (4) and low oil pressure warning light sending unit (3) from cylinder block (2).

NOTE

Perform step 2 for Big Cam I engines only.

2. Remove transmission control-body heating elements ON/OFF switch (1) from cylinder block (2).
3. Remove oil level dipstick (9) from oil level dipstick tube and cover (10).
4. Remove screw (8), lockwasher (7), and washer (6) from tube brace (5). Discard lockwasher (7).
5. Remove nut (11), lockwasher (12), two washers (13), screw (8), clamp (14), and tube brace (5) from oil level dipstick tube and cover (10).
6. Remove four captive washer screws (15), washers (16), oil level dipstick tube and cover (10), and gasket (17) from cylinder block (2). Discard gasket (17).

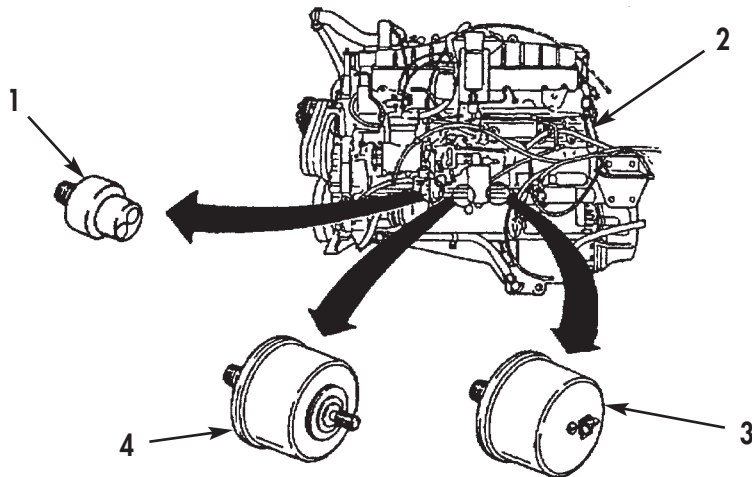


Figure 1. Oil Pressure Gauge Sensing Unit Removal.

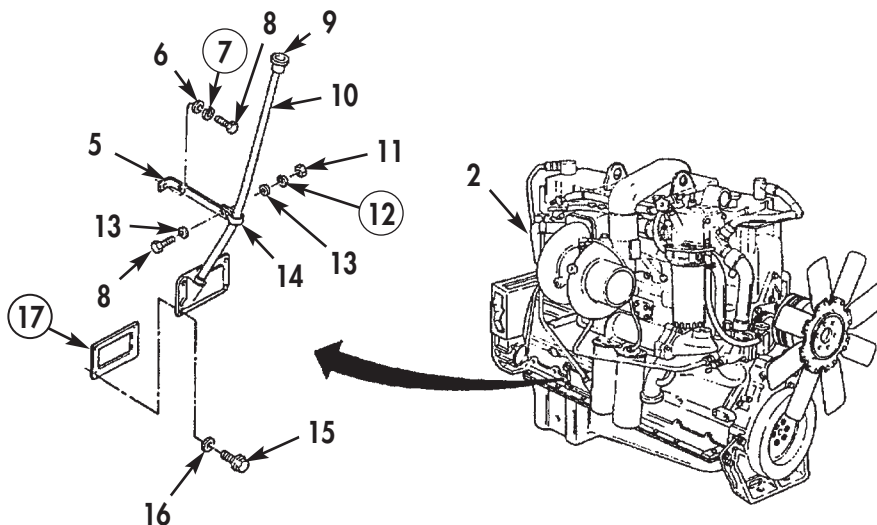


Figure 2. Oil Level Dipstick Tube Removal.

MOUNTING ENGINE ON MAINTENANCE STAND (Contd)

7. Loosen clamps (23) and (25) retaining turbocharger air crossover (22) and hose (24) to turbocharger (26).
8. Remove hose (18) and fitting (19) from turbocharger air crossover (22).
9. Remove four bolts (20), washers (21), turbocharger air crossover (22), hose (24) and gasket (28) from aftercooler cover (27) and turbocharger (26). Discard hose (24) and gasket (28).
10. Remove bolt (30) securing clamp (29) and turbocharger oil supply hose (28) to turbocharger adapter (27) and elbow (31).
11. Remove turbocharger oil supply hose (28) from turbocharger (26).

NOTE

Perform step 12 for Big Cam I only.

12. Loosen clamps (40) and (42), and remove oil return tube (38) from elbows (37) and (45).

NOTE

Perform steps 13 and 14 for Big Cam III only.

13. Remove oil return tube (36) and two bushings (43) and (46) from oil return tube (39) and filter head (44).
14. Remove oil return tube (38), two clamps (40) and (42), and hose (41) from elbows (35) and (45).
15. Remove four nuts (34), turbocharger (26), and gasket (33) from exhaust manifold (32). Discard gasket (33).
16. For turbocharger (26) repair, refer to WP 0026 00 or WP 0027 00.

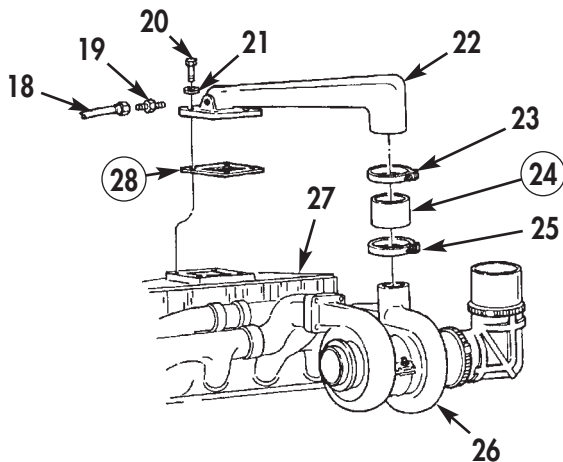


Figure 3. Turbocharger Air Crossover Removal.

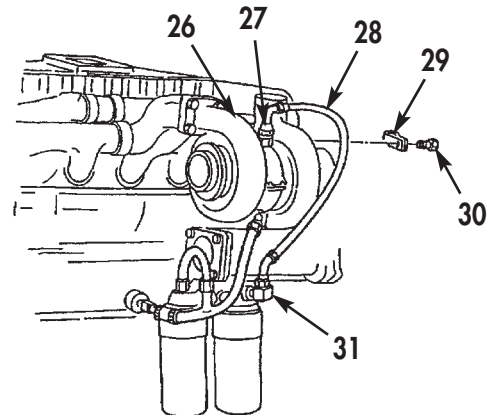


Figure 4. Turbocharger Oil Supply Hose Removal.

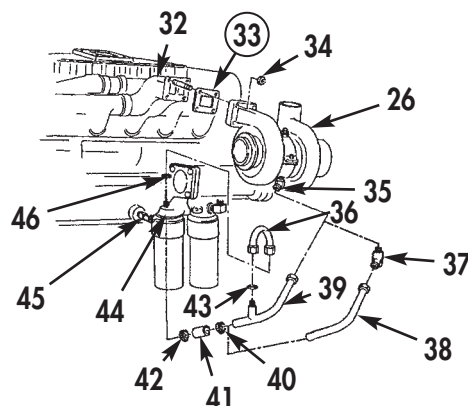


Figure 5. Turbocharger Removal.

MOUNTING ENGINE ON MAINTENANCE STAND (Contd)

NOTE

Perform steps 17 and 18 for Big Cam I only.

17. Bend tabs of four lockplates (4) and remove eight bolts (6), lockwashers (5), and lockplates (4) securing exhaust manifold (3) to cylinder head (1) and dowels (13). Discard lockplates (4) and lockwashers (5).
18. Bend tabs of two lockplates (11) and remove four bolts (10), lockplates (11), clamps (12), exhaust manifold (3), and six gaskets (2) from cylinder heads (1). Discard lockplates (11) and gaskets (2).

NOTE

Perform step 19 for Big Cam III only.

19. Remove twelve captive head screws (9), exhaust manifold (7), and six gaskets (2) from cylinder heads (1). Discard gaskets (2). Do not separate manifolds and spacer inserts (8) at this time.
20. For exhaust manifold (7) or (3) repair, refer to WP 0025 00.

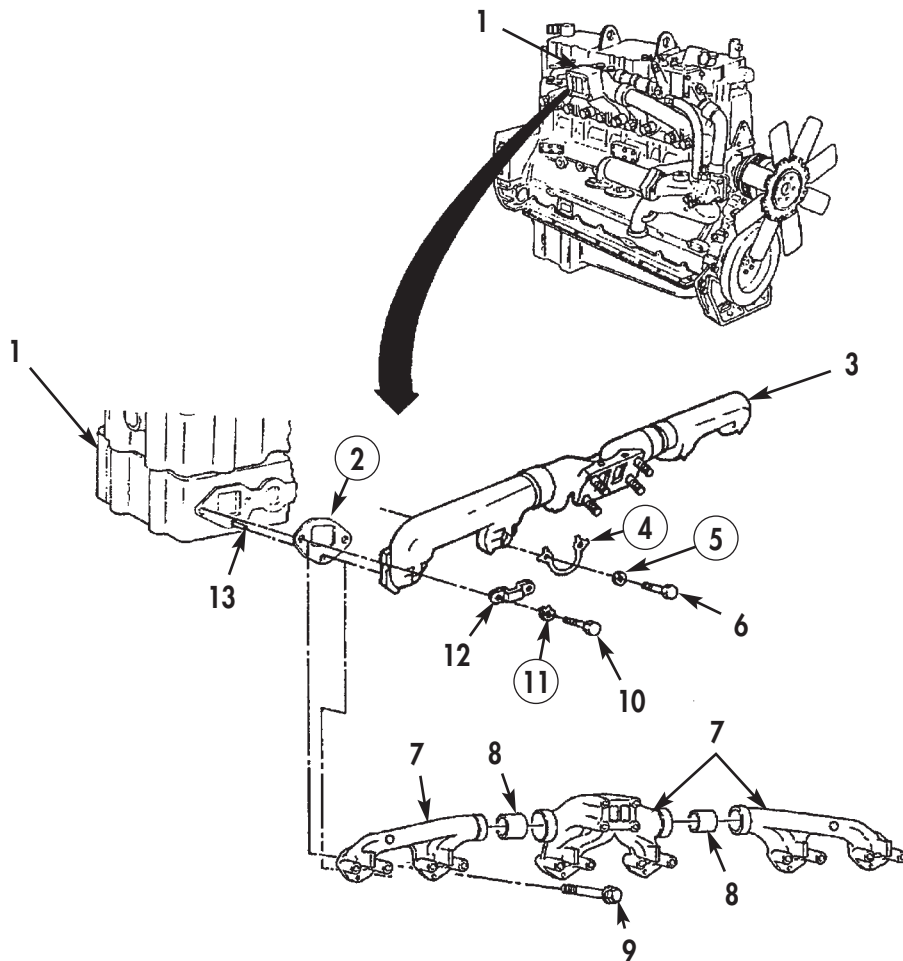


Figure 6. Exhaust Manifold Removal.

MOUNTING ENGINE ON MAINTENANCE STAND (Contd)

NOTE

Perform steps 21 through 23 for Big Cam I only.

21. Remove screw (23) and lockwasher (17) securing oil cooler support bracket (18) to cylinder block (14). Discard lockwasher (17).
22. Loosen clamp (16) and remove water transfer hose (15) from oil cooler (22).
23. Remove five screws (19), lockwashers (20), oil cooler (22), and gasket (21) from cylinder block (14). Discard lockwashers (20) and gasket (21).

NOTE

Perform steps 24 and 25 for Big Cam III only.

24. Remove two screws (27), lockwashers (28), and washers (29) securing rear of oil cooler (30) to cylinder block (14). Discard lockwashers (28).
25. Remove six screws (26), lockwashers (25), oil cooler (30), and gasket (24) from cylinder block (14). Discard lockwashers (25) and gasket (24).
26. For oil cooler (30) or (22) repair, refer to WP 0021 00.

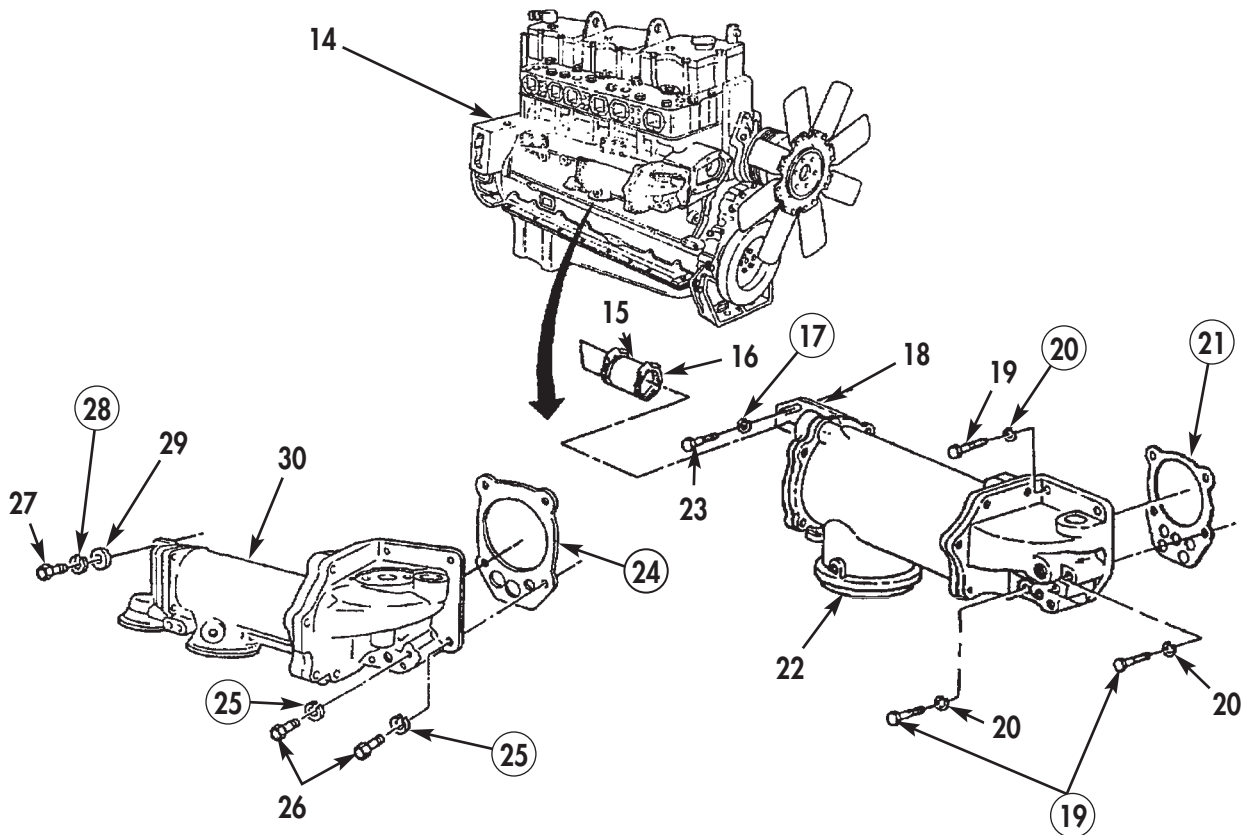


Figure 7. Oil Cooler Removal.

MOUNTING ENGINE ON MAINTENANCE STAND (Contd)

NOTE

Perform steps 27 and 28 for Big Cam I only.

27. Loosen four clamps (5) and remove two water transfer hoses (4) and water transfer tube (6) from water transfer flange (2). Discard hoses (4).
28. Remove six screws (1), water transfer flange (2), and gasket (3) from cylinder block (7). Discard gasket (3).

NOTE

Perform steps 29 through 31 for Big Cam III only.

29. Remove twelve screws (10), two water header covers (9), and gaskets (8) from cylinder block (7). Discard gaskets (8).
30. Remove six screws (13) and piston cooling nozzles (12) from cylinder block (7).
31. Remove six O-rings (11) from piston cooling nozzles (12). Discard O-rings (11).

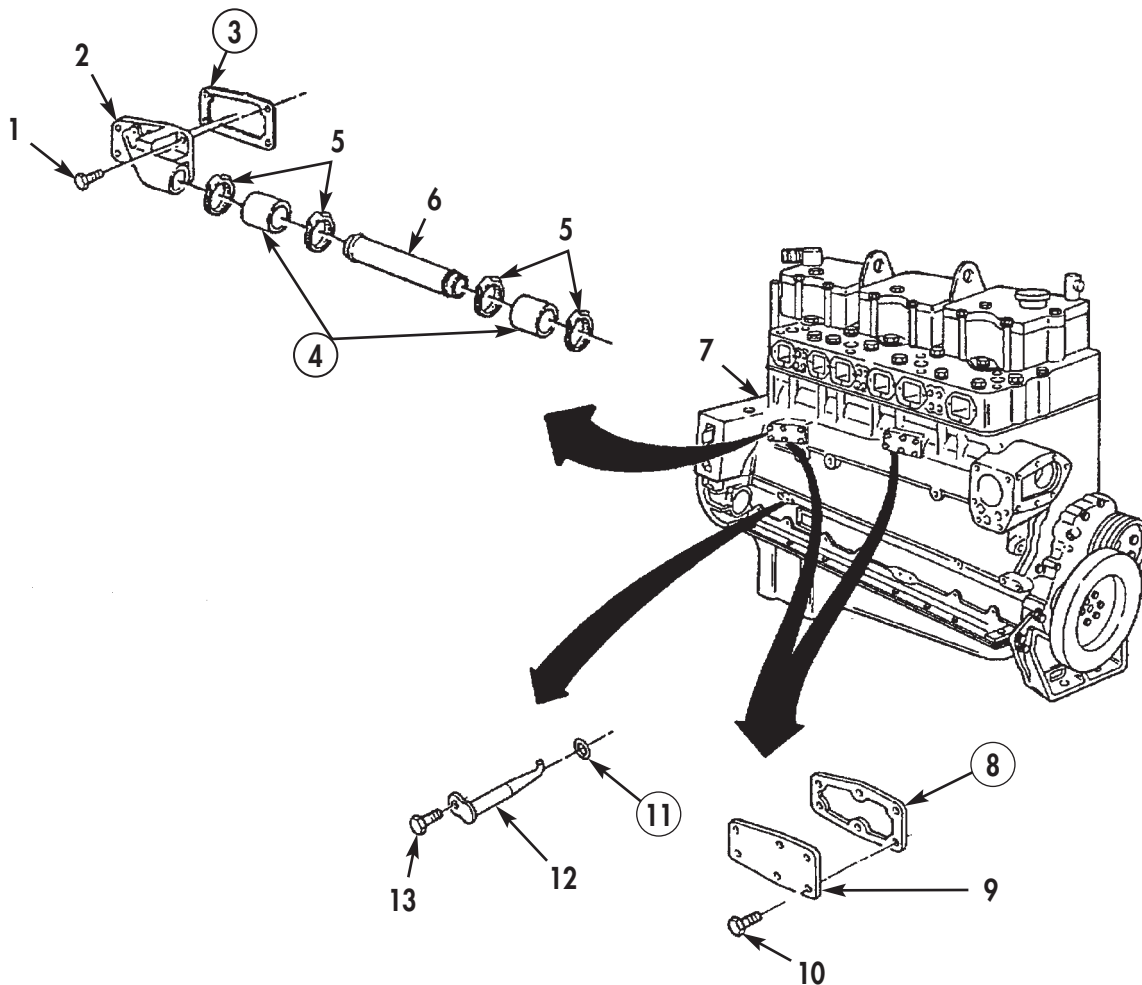


Figure 8. Piston Cooling Nozzles Removal.

MOUNTING ENGINE ON MAINTENANCE STAND (Contd)

32. Install right side of cylinder block (7) on maintenance stand with four screws (14).
33. Remove engine lifting device from engine lifting brackets.

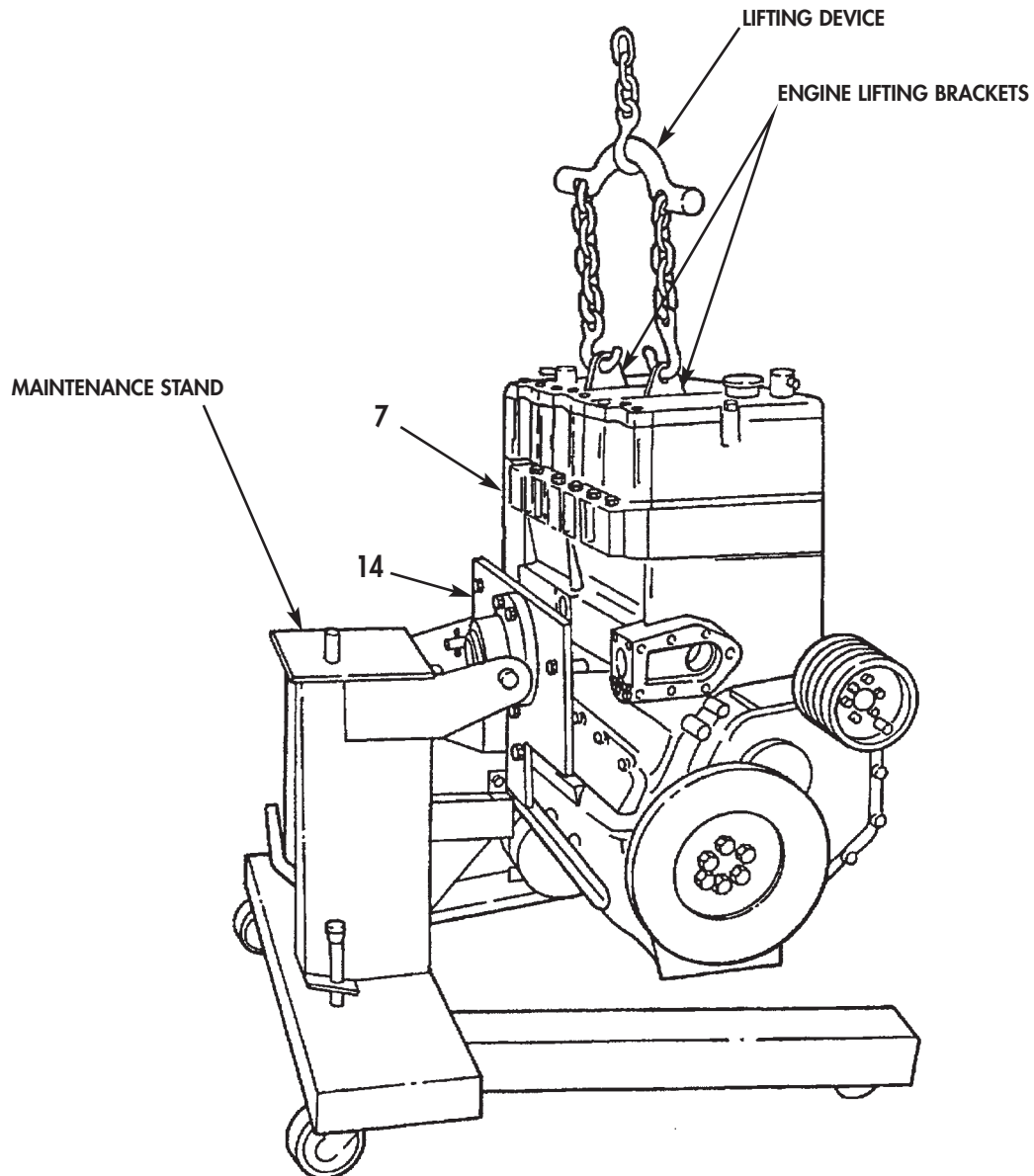


Figure 9. Mounting Engine on Maintenance Stand.

**DIRECT SUPPORT AND GENERAL SUPPORT
MAINTENANCE MANUAL
INCLUDING REPAIR PARTS AND SPECIAL TOOLS LIST (RPSTL)**

FOR

M915, M915A1, M915A4, M916, M920 VEHICLES

NSN 2815-01-082-8125	P/N NTC400-3652-02	CUMMINS NTC-400 BIG CAM I DIESEL ENGINE W/CONTAINER
NSN 2815-01-142-2745	P/N 11669835	CUMMINS NTC-400 BIG CAM III DIESEL ENGINE W/CONTAINER

ENGINE ACCESSORIES REMOVAL

**VIBRATION DAMPER AND CRANKSHAFT PULLEY, ACCESSORY DRIVE PULLEY, FUEL PUMP AND
FUEL LINES, AIR COMPRESSOR, ACCESSORY DRIVE HOUSING, OIL PUMP, AIR AFTERCOOLER**

INITIAL SETUP:

Tools and Special Tools

General mechanic's tool kit:
automotive (Item 1, WP 0061 00)
Maintenance and repair shop equipment:
automotive (Item 2, WP 0061 00)
Automotive maintenance and repair
supplemental set no. 2 (Item 3, WP 0061 00)
Air compressor wrench
(Item 18, WP 0061 00)

Equipment Condition

Engine mounted on maintenance stand
(WP 0009 00).

Materials/Parts

Cap and plug set (Item 29, WP 0060 00)

ENGINE ACCESSORIES REMOVAL (Contd)

VIBRATION DAMPER AND CRANKSHAFT PULLEY

WARNING

Use extreme care during engine accessory removal. Engine parts are heavy. Failure to do so may result in death or injury to personnel.

CAUTION

Do not pound on vibration damper with hammer or other tools during removal. Damage to vibration damper will occur.

1. Insert prybar in teeth of flywheel and flywheel housing to prevent crankshaft (5) from turning.
2. Remove six screws (1), washers (2), vibration damper (3), and crankshaft pulley (4) from crankshaft (5).

ACCESSORY DRIVE PULLEY

NOTE

Perform steps 1 through 4 for Big Cam III engines only.

Do not let accessory drive pulley rotate when removing screws.

1. Remove six screws (6) and front accessory drive pulley (9) from rear accessory drive pulley (11).
2. Remove locknut (7) and washer (8) retaining rear accessory drive pulley (11) on accessory driveshaft (12). Discard locknut (7).

CAUTION

Do not use jaw-type puller. Damage to accessory drive pulley may result.

When installing puller, ensure screws do not bottom-out against front cover, or damage to front cover will result.

3. Using puller, remove rear accessory drive pulley (11) from accessory driveshaft (12).
4. Remove keyway seal (10) from accessory driveshaft (12). Discard keyway seal (10).

NOTE

Perform steps 5 through 7 for Big Cam I engines only.

5. Remove locknut (7) and washer (8) retaining accessory drive pulley (13) on accessory driveshaft (12). Discard locknut (7).

CAUTION

Do not use jaw-type puller. Damage to accessory drive pulley may result.

6. Using puller, remove accessory drive pulley (13) from accessory driveshaft (12).
7. Remove keyway seal (10) from accessory driveshaft (13). Discard keyway seal (10).
8. For accessory drive pulley (9) and (13) repair, refer to WP 0029 00.

ENGINE ACCESSORIES REMOVAL (Contd)

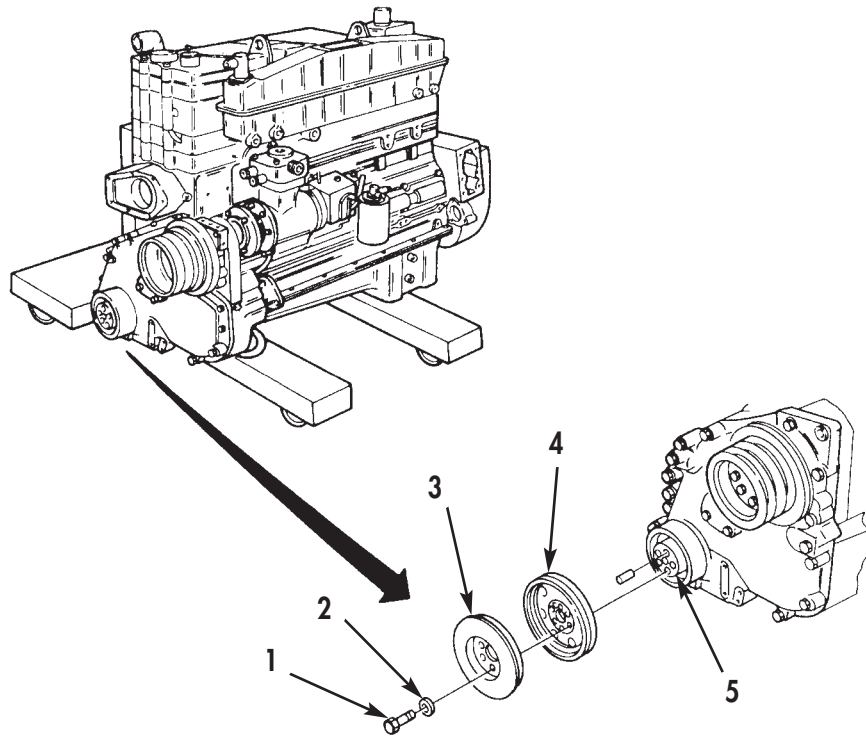


Figure 1. Vibration Damper and Crankshaft Pulley Removal.

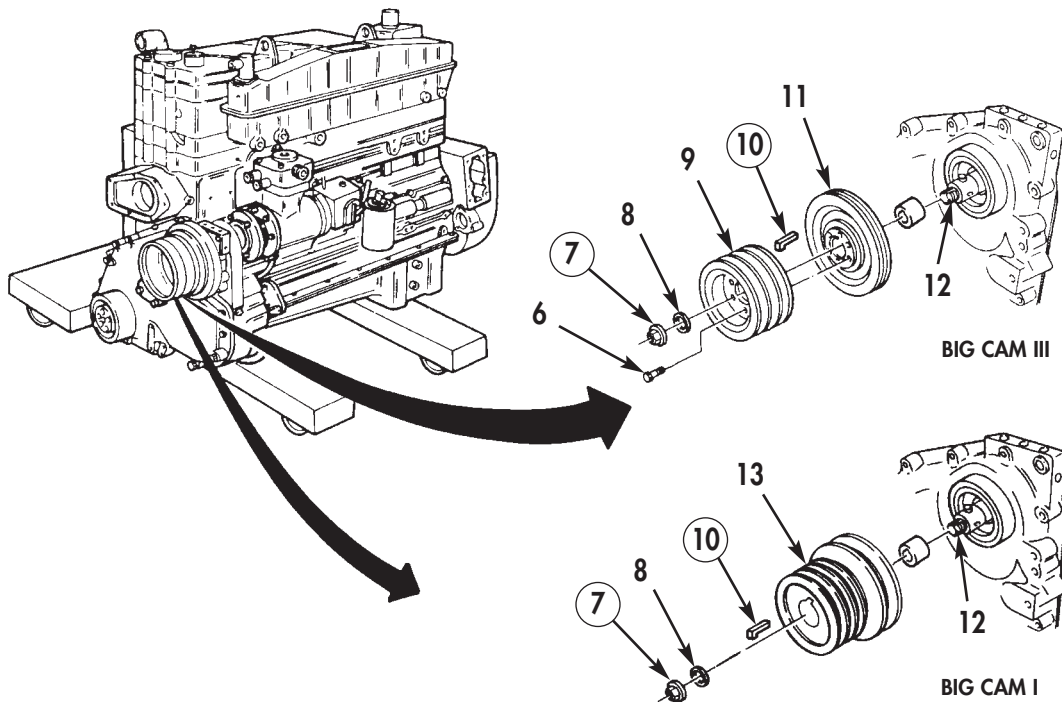


Figure 2. Accessory Drive Pulley Removal.

ENGINE ACCESSORIES REMOVAL (Contd)

FUEL PUMP AND FUEL LINES

NOTE

Cap or plug all openings immediately after removal to prevent contamination.

Perform steps 1 through 4 for Big Cam I equipped with air signal attenuator (ASA) air tank.

1. Remove four hose clamps (3) and two air supply hoses (4) from ASA air tank (1).
2. Remove air aftercooler elbow (5) from air aftercooler (6).
3. Remove ASA hose fittings (2) from ASA air tank (1).
4. Remove screw (21), lockwasher (20), washer (19), and ASA air tank (1) from air aftercooler (6). Discard lockwasher (20).
5. Remove nut (22), lockwasher (23), washer (24), and screw (18) securing bracket (25) and air supply line (26) to air aftercooler (6). Discard lockwasher (23).
6. Remove adapter (17) from air aftercooler (6).
7. Remove air supply line (26) and valve (27) from fuel pump (29).
8. Remove two screws (13), lockwashers (12), and washers (11) securing fuel supply line (9) and fuel return line (10) to air aftercooler (6). Discard lockwashers (12).
9. Remove fuel return lines (10) and (15) and fuel pump adapter (28) from fuel pump (29).
10. Remove fuel supply line (9) and fuel pump adapter (16) from fuel pump (29).
11. Remove fuel return line (10), fuel supply line (9), and two cylinder head adapters (8) from cylinder head (7).
12. Remove fuel pump adapter (14) from fuel pump (29).

ENGINE ACCESSORIES REMOVAL (Contd)

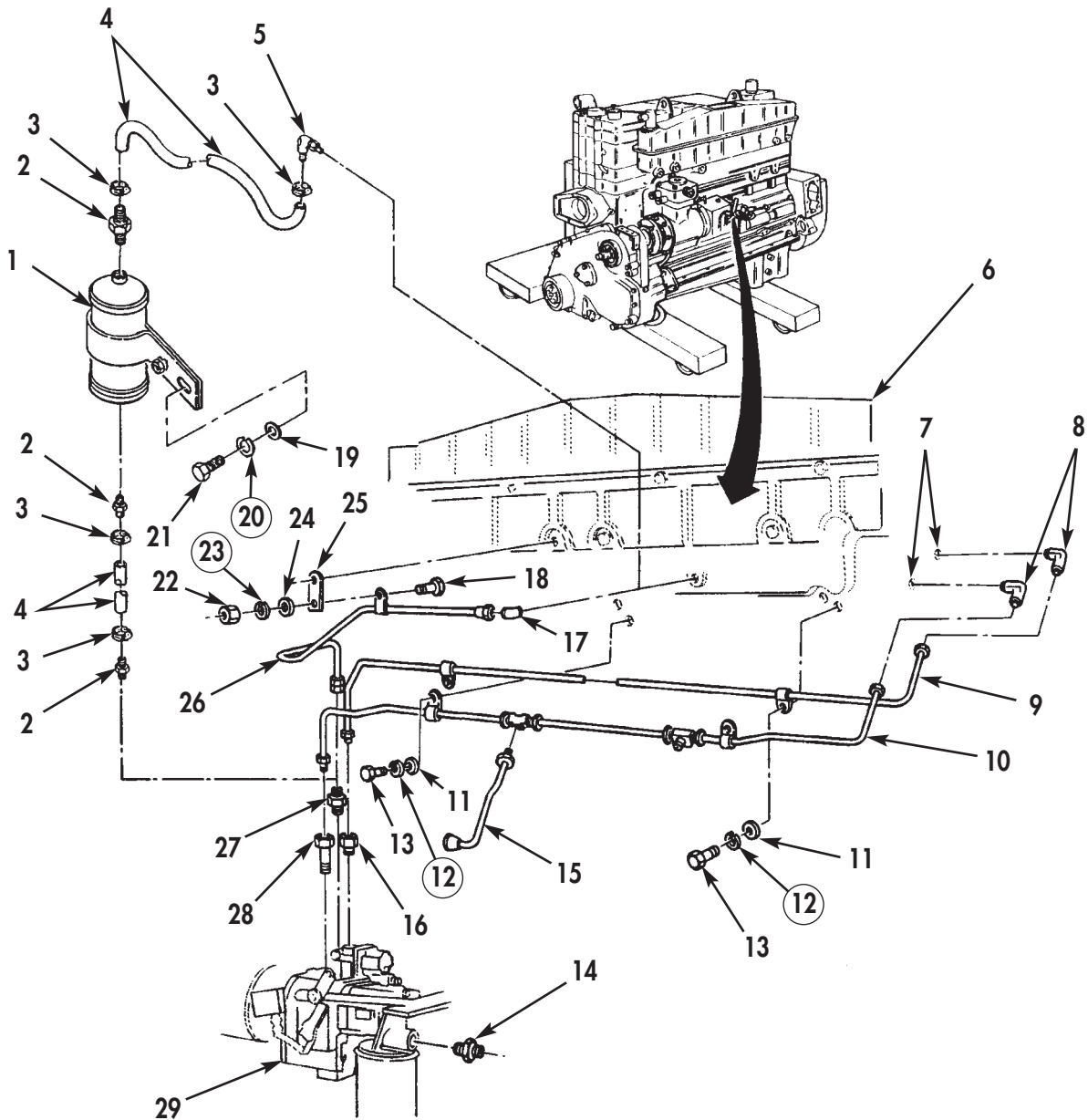


Figure 3. Fuel Lines Removal.

ENGINE ACCESSORIES REMOVAL (Contd)

FUEL PUMP AND FUEL LINES (Contd)

13. Remove bolt (6) and lockwasher (7) securing support bracket (9) to cylinder head (8). Discard lockwasher (7).

NOTE

Perform step 14 for Big Cam I only.

14. Using air compressor wrench, remove four bolts (5), washers (4), support bracket (9) securing and fuel pump (12) to air compressor (1).

NOTE

Perform steps 15 and 16 for Big Cam III only.

15. Using air compressor wrench, remove bolt (13) and washer (14) securing fuel pump (12) to air compressor (1).
16. Remove three bolts (11), washers (10), and support bracket (9) securing fuel pump (12) to air compressor (1).
17. Using a soft-sided mallet, tap fuel pump (12) lightly to remove from air compressor (1).

NOTE

Gasket and spider coupling may remain on air compressor or fuel pump during removal.

18. Remove gasket (2) and spider coupling (3) from air compressor (1) or fuel pump (12). Discard gasket (2).
19. For fuel pump repair, refer to WP 0033 00.

ENGINE ACCESSORIES REMOVAL (Contd)

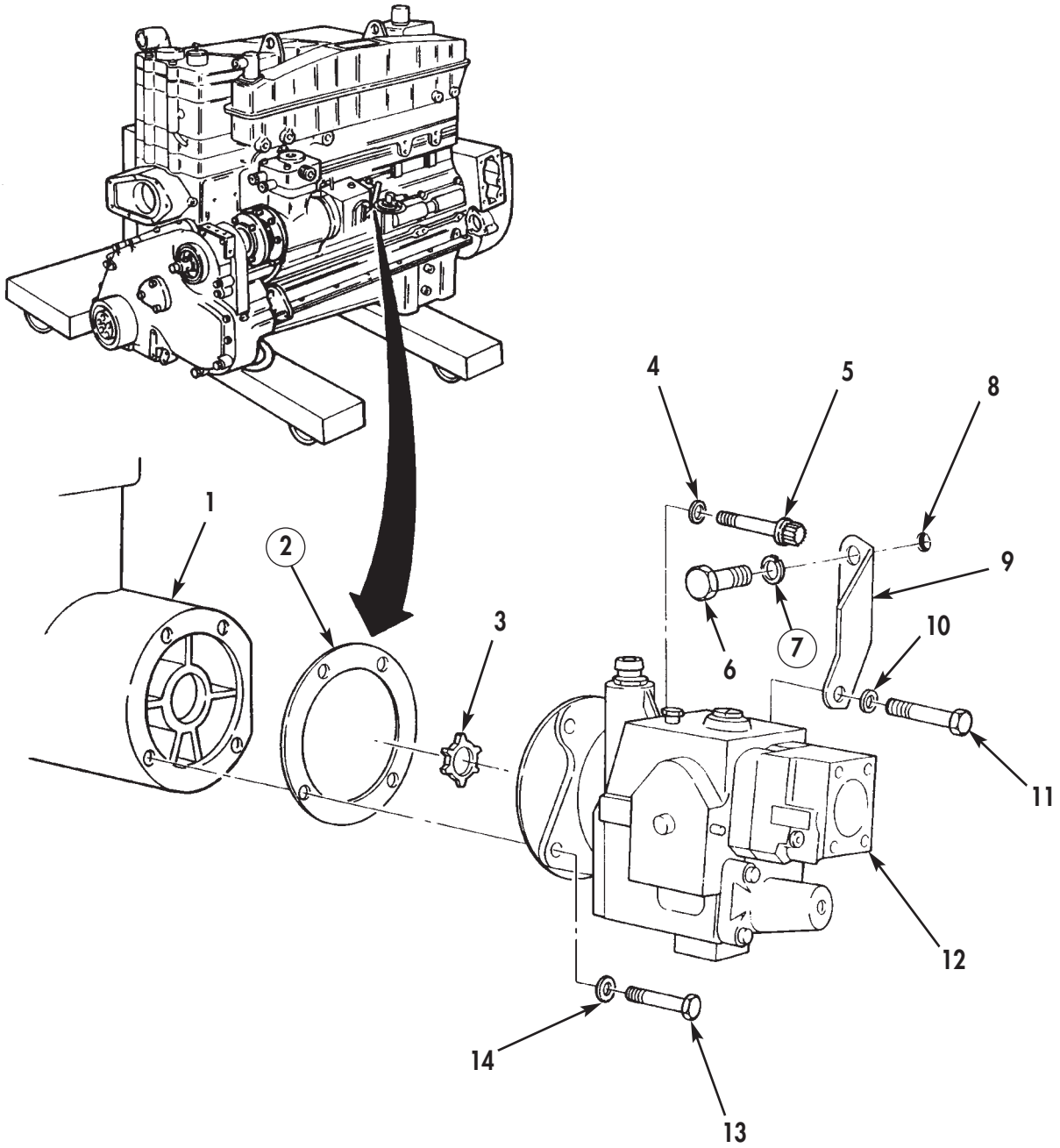


Figure 4. Fuel Pump Removal.

ENGINE ACCESSORIES REMOVAL (Contd)

AIR COMPRESSOR

NOTE

Big Cam III is shown. Big Cam I is similar.

1. Remove coolant inlet tube (11), coolant outlet tube (4), two bushings (3), and elbow (2) from air coolant adapters (1) and (12). Discard bushings (3).
2. Remove coolant inlet tube (11), coolant outlet tube (4), two bushings (3), and two adapters (5) from air compressor (6). Discard bushings (3).
3. Remove two air inlet hose clamps (8) and air inlet hose (9) from air compressor (6) and elbow (7).
4. Remove elbow (7) from cylinder block (10).
5. Using air compressor wrench, remove two bolts (21) and lockwashers (20) securing air compressor (6) to accessory drive housing (13). Discard lockwashers (20).
6. Remove two nuts (19), lockwashers (18), washers (17), and bolts (14) securing air compressor (6) to accessory drive housing (13). Discard lockwashers (18).
7. Remove air compressor (6) from accessory drive housing (13).

NOTE

Gasket and drive coupling may remain on air compressor or accessory drive housing during removal.

8. Remove gasket (16) and drive coupling (15) from air compressor (6) or accessory drive housing (13). Discard gasket (16).
9. For air compressor repair, refer to WP 0031 00.

ENGINE ACCESSORIES REMOVAL (Contd)

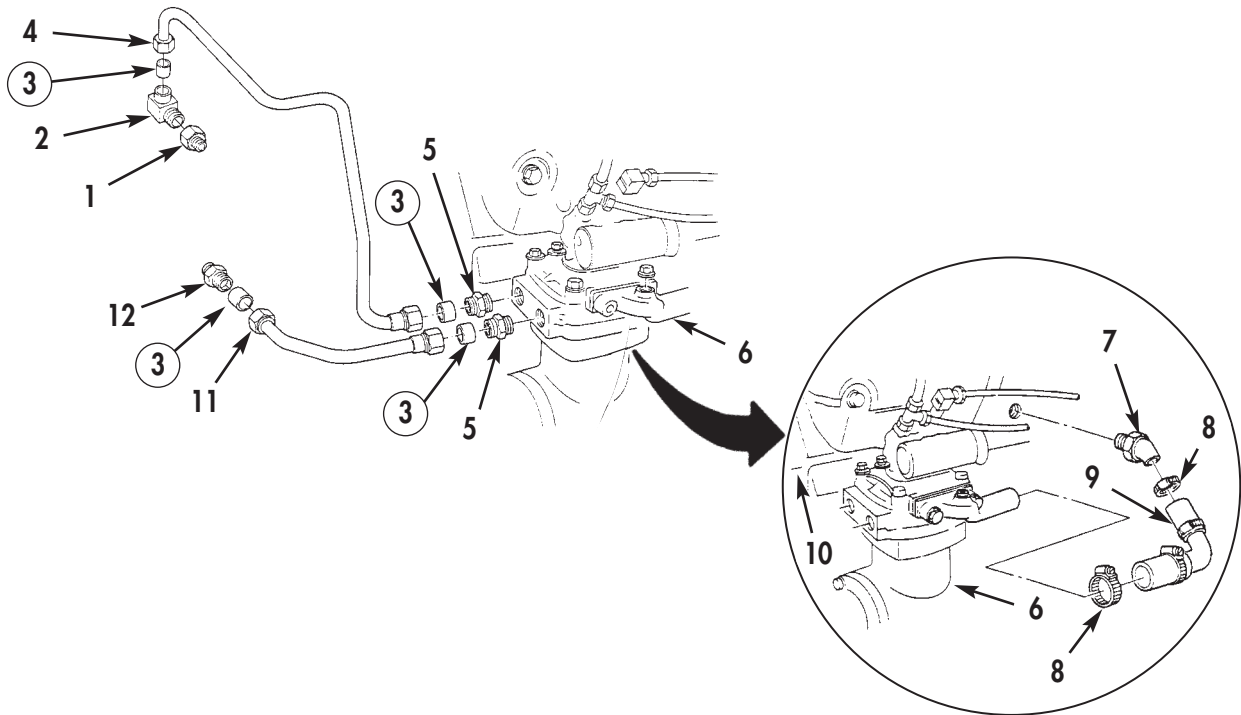


Figure 5. Air Compressor Lines Removal.

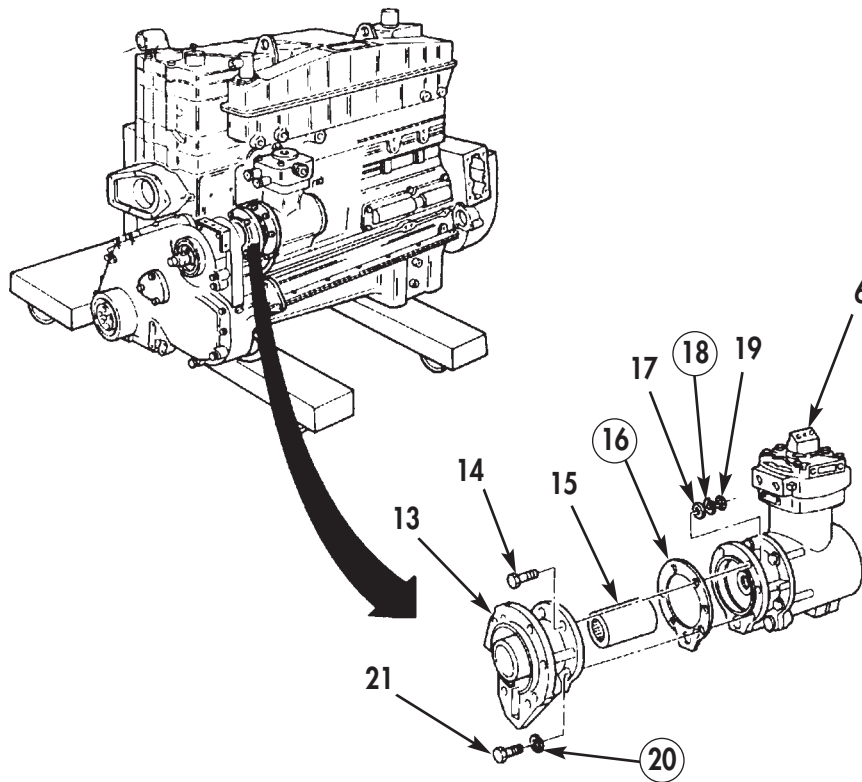


Figure 6. Air Compressor Removal.

ENGINE ACCESSORIES REMOVAL (Contd)

ACCESSORY DRIVE HOUSING

1. Remove five bolts (4), accessory drive housing (3), and gasket (2) from front gear cover (1). Discard gasket (2).
2. For accessory drive housing assembly repair, refer to WP 0029 00.

OIL PUMP

NOTE

Perform steps 1 through 6 for Big Cam III.

1. Remove two screws (16), lockwashers (15), and washers (14) securing oil suction tube (13) to oil pan (20). Discard lockwashers (15).
2. Remove two screws (17), lockwashers (18), washers (19), and oil suction tube (13) from oil pan (20) and oil pump (7). Discard lockwashers (18).
3. Remove two O-rings (12) and one gasket (11) from oil suction tube (13). Discard O-rings (12) and gasket (11).
4. Remove oil transfer tube (8) from oil pump (7) and cylinder block (5).
5. Remove five bolts (9) and lockwashers (10) securing oil pump (7) to accessory drive housing (21). Discard lockwashers (10).
6. Remove oil pump (7) and gasket (6) from accessory drive housing (21). Discard gasket (6).

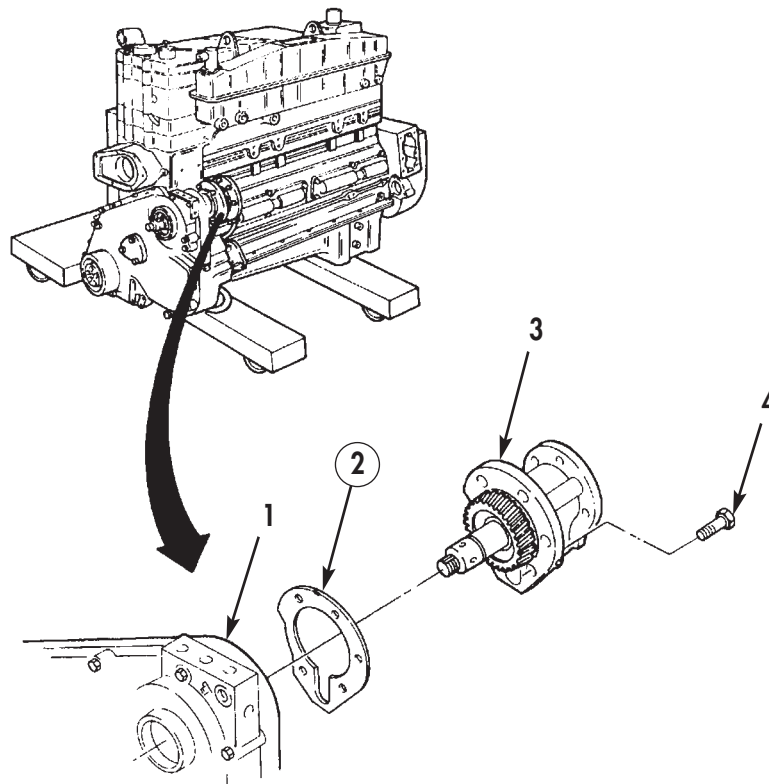


Figure 7. Accessory Drive Housing Removal.

ENGINE ACCESSORIES REMOVAL (Contd)

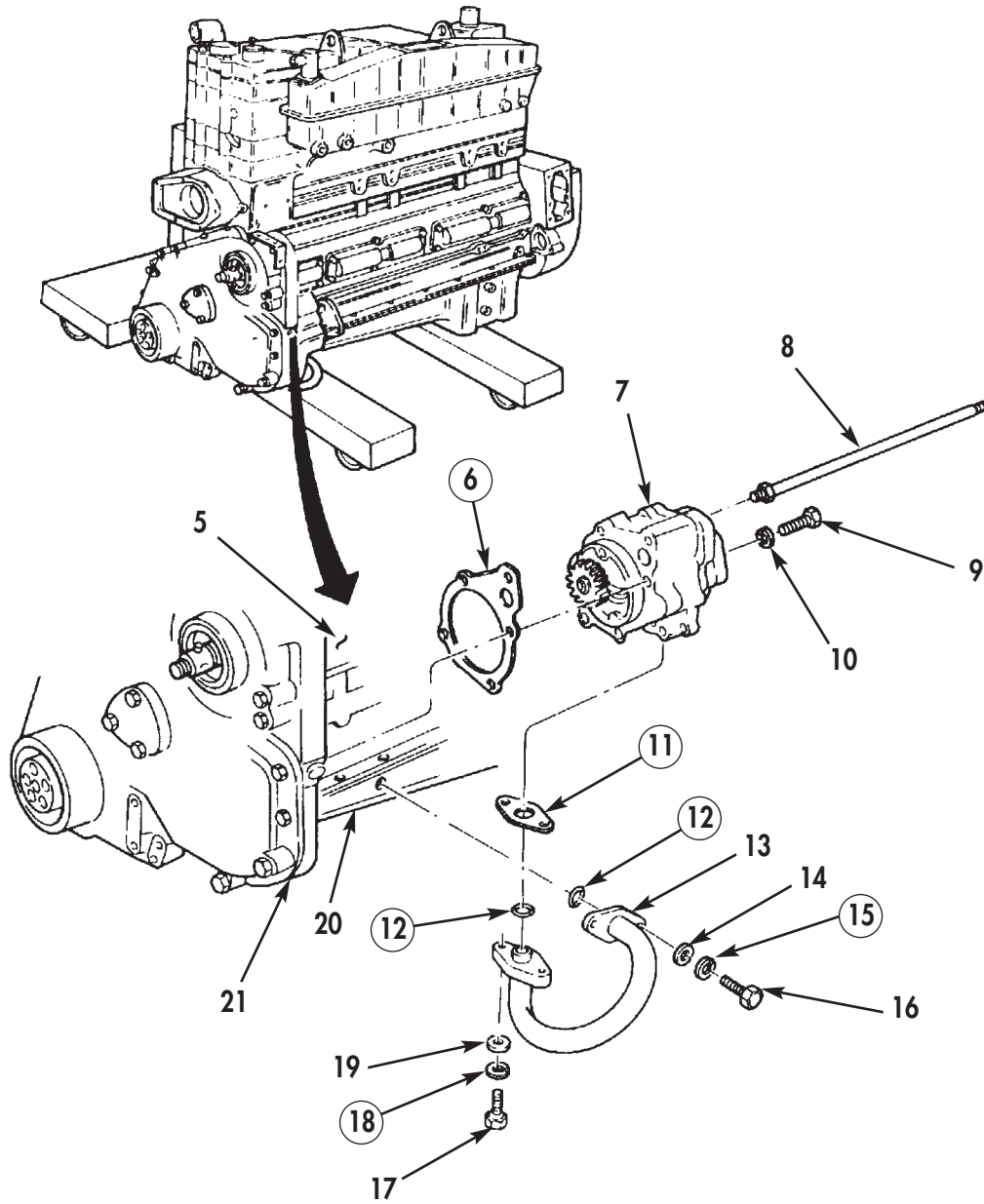


Figure 8. Big Cam III Oil Pump Removal.

ENGINE ACCESSORIES REMOVAL (Contd)

OIL PUMP (Contd)

NOTE

Perform steps 7 through 13 for Big Cam I.

7. Remove bolt (14), lockwasher (13), washer (12), clamp (11), spacer (10), and locknut (15) securing oil suction hose (5) to bracket (9). Discard lockwasher (13) and locknut (15).
8. Remove bolt (17), lockwasher (16), and bracket (9) from oil pan (21) and cylinder block (1). Discard lockwasher (16).
9. Remove two screws (6), lockwashers (7), oil suction hose (5), and gasket (8) from oil pan (21). Discard lockwashers (7) and gasket (8).
10. Remove oil suction hose (5) and adapter (4) from cylinder block (1).
11. Remove three long bolts (18), two short bolts (20), and five lockwashers (19) securing oil pump (3) to accessory drive housing (22). Discard lockwashers (19).
12. Remove oil pump (3) and gasket (2) from accessory drive housing (22). Discard gasket (2).
13. For oil pump repair, refer to WP 0023 00.

ENGINE ACCESSORIES REMOVAL (Contd)

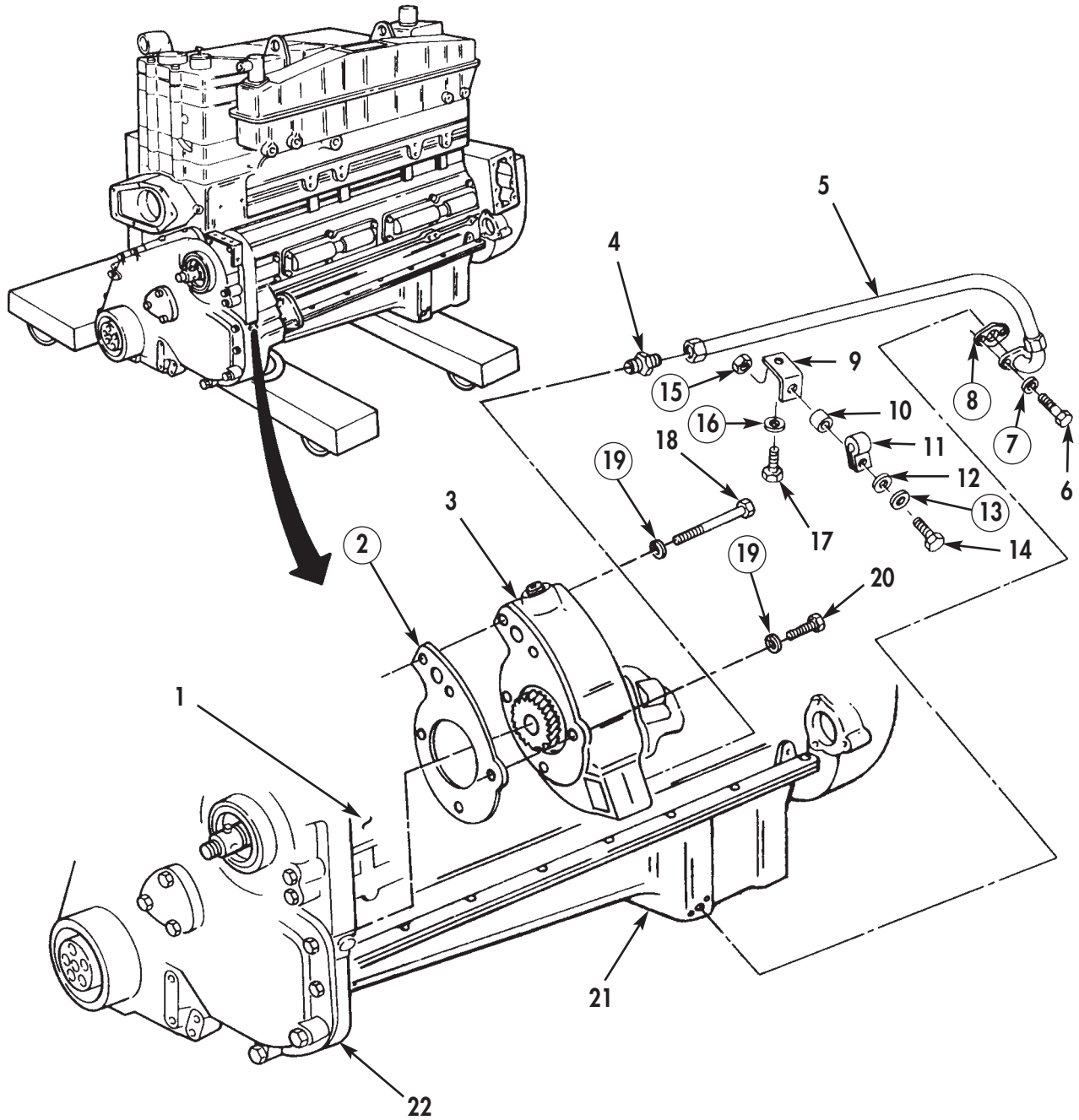


Figure 9. Big Cam I Oil Pump Removal.

ENGINE ACCESSORIES REMOVAL (Contd)

AIR AFTERCOOLER

NOTE

Perform steps 1 and 2 for Big Cam I only.

1. Remove three bolts (5), lockwashers (4), and washers (3) securing air aftercooler (2) to cylinder heads (1). Discard lockwashers (4).
2. Remove six bolts (7) and washers (6) securing air aftercooler (2) to cylinder heads (1).

NOTE

Perform steps 3 through 6 for Big Cam III only.

3. Remove screw (8), lockwasher (4), and washer (3) securing air aftercooler (2) to cylinder heads (1). Discard lockwasher (4).
4. Remove two screws (5), lockwashers (4), and washers (3) securing air aftercooler (2) to cylinder heads (1). Discard lockwashers (4).
5. Remove six screws (7) and washers (6) securing air aftercooler (2) to cylinder heads (1).
6. Remove air aftercooler (2) and three gaskets (9) from cylinder heads (1). Discard gaskets (9).
7. For air aftercooler repair, refer to WP 0024 00.

ENGINE ACCESSORIES REMOVAL (Contd)

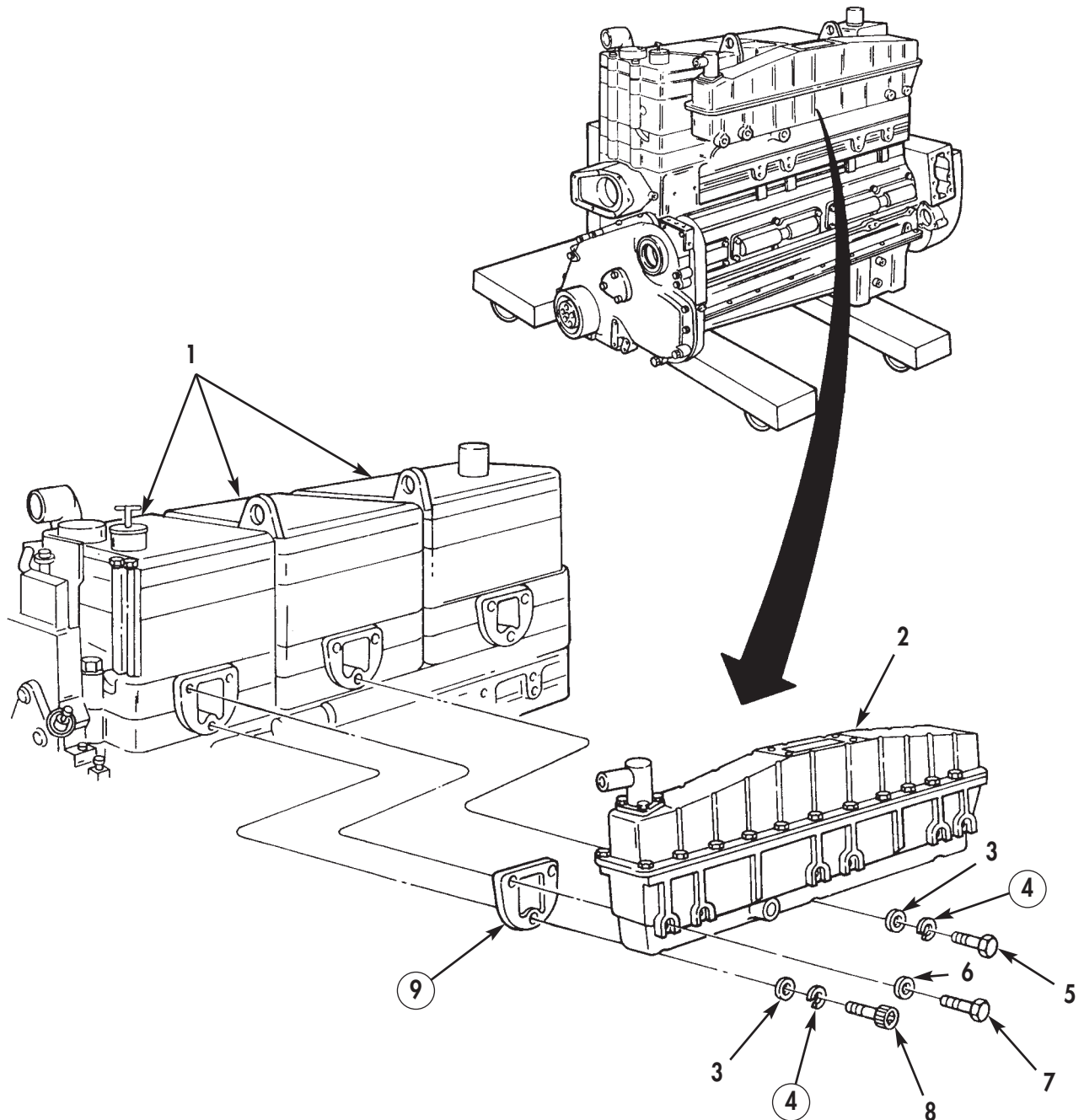


Figure 10. Air Aftercooler Removal.

**DIRECT SUPPORT AND GENERAL SUPPORT
MAINTENANCE MANUAL
INCLUDING REPAIR PARTS AND SPECIAL TOOLS LIST (RPSTL)**

FOR

M915, M915A1, M915A4, M916, M920 VEHICLES

NSN 2815-01-082-8125	P/N NTC400-3652-02	CUMMINS NTC-400 BIG CAM I DIESEL ENGINE W/CONTAINER
NSN 2815-01-142-2745	P/N 11669835	CUMMINS NTC-400 BIG CAM III DIESEL ENGINE W/CONTAINER

CYLINDER HEAD AND CYLINDER HEAD COMPONENTS REMOVAL

ROCKER COVER, ENGINE BRAKE RETARDER, ROCKER ARM HOUSING, FUEL INJECTOR, CYLINDER HEAD

INITIAL SETUP:

Tools and Special Tools

General mechanic's tool kit: automotive
(Item 1, WP 0061 00)
Maintenance and repair shop equipment:
automotive (Item 2, WP 0061 00)
Automotive maintenance and repair
supplemental set no. 2 (Item 3, WP 0061 00)
Fuel injector puller (Item 8, WP 0061 00)

Equipment Condition

Engine mounted on maintenance stand
(WP 0009 00).
Engine accessories removed (WP 0010 00).

Material/Parts

Lint-free cloth (Item 6, WP 0060 00)

CYLINDER HEAD AND CYLINDER HEAD COMPONENTS REMOVAL (Contd)

ROCKER COVER

1. Remove five screws (1), rocker cover (2), and gasket (3) from engine brake retarder (4). Discard gasket (3).
2. Repeat step 1 to remove remaining two rocker covers (2).

ENGINE BRAKE RETARDER

WARNING

Use extreme care during cylinder head disassembly. Cylinder head parts are heavy. Failure to do so may result in death or injury to personnel.

1. Scribe a locating mark (7) on engine brake retarder (4) and rocker arm housing (10) before removal.
2. Bend tabs on locking plates (5) down and remove six nuts (6) and locking plates (5) securing engine brake retarder (4) on studs (11) in rocker arm housing (10). Discard locking plates (5).
3. Remove engine brake retarder (4), gasket (8), and O-ring (9) from rocker arm housing (10). Discard gasket (8) and O-ring (9).
4. Repeat steps 1 through 3 to remove remaining two engine brake retarders (4).
5. For engine brake retarder (4) repair, refer to WP 0030 00.

CYLINDER HEAD AND CYLINDER HEAD COMPONENTS REMOVAL (Contd)

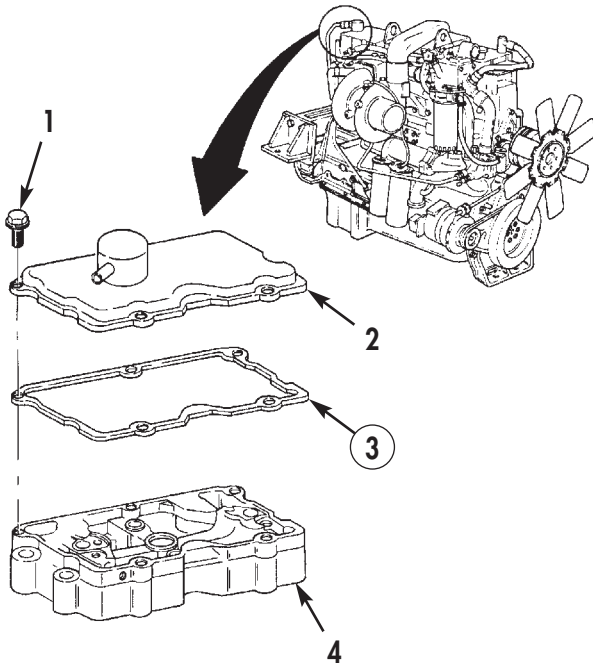


Figure 1. Rocker Cover Removal.

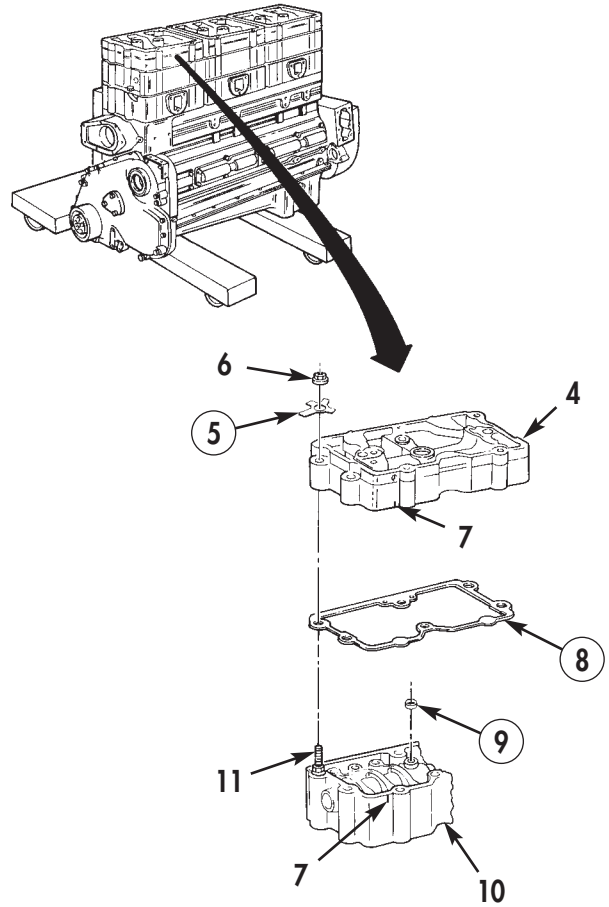


Figure 2. Engine Brake Retarder Removal.

CYLINDER HEAD AND CYLINDER HEAD COMPONENTS REMOVAL (Contd)

ROCKER ARM HOUSING

1. Scribe a locating mark (6) on rocker arm housing (1) and cylinder head (11) before removal.
2. Loosen six adjusting nuts (5) and screws (4) by turning counter-clockwise to until tension is relieved.
3. Remove six rocker arm housing studs (3) and washer bearings (2) securing rocker arm housing (1) to cylinder head (11). Discard washer bearings (2).
4. Remove rocker arm housing (1) and gasket (10) from cylinder head (11). Discard gasket (10).

NOTE

Mark each pushrod or place in a suitable rack in the order they are removed to ensure proper installation.

5. Remove two intake pushrods (7), injector pushrods (8), and exhaust pushrods (9) from cylinder head (11).
6. Repeat steps 1 through 5 to remove remaining two rocker arm housings (1).
7. For rocker arm housing and shaft repair, refer to WP 0020 00.

FUEL INJECTOR

NOTE

Fuel injectors on Big Cam III engines maybe retained with a clamp instead of a retaining plate. Removal procedures are the same for Big Cam I and Big Cam III engines.

1. Remove two screws (12) and retaining plate (13) securing fuel injector (15) in cylinder head (11).
2. Remove detent plunger (14) from fuel injector (15).
3. Using fuel injector puller, remove fuel injector (15) from cylinder head (11).

NOTE

Ensure injectors, injector links, and plungers are not intermixed. Keep all injector parts with individual injectors. Place all injectors in a suitable rack in the order they were removed to ensure proper installation.

4. Wrap each fuel injector (15) in clean lint free cloth after removal to prevent dirt from entering fuel injector (15) openings.
5. Repeat steps 1 through 4 for remaining fuel injectors (15).
6. For fuel injector (15) repair, refer to WP 0032 00.

CYLINDER HEAD AND CYLINDER HEAD COMPONENTS REMOVAL (Contd)

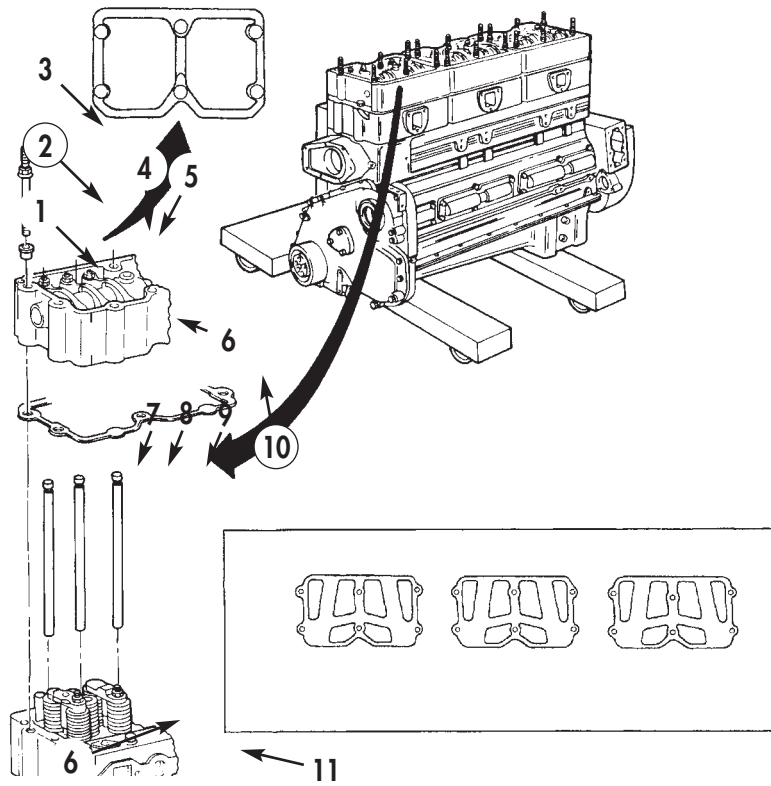


Figure 3. Rocker Arm Housing and Push Rod Removal.

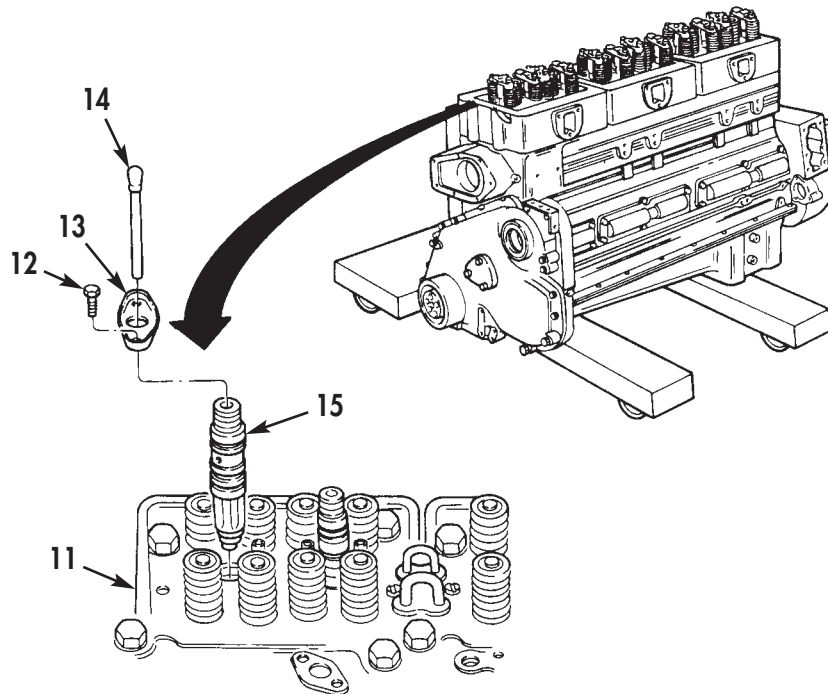


Figure 4. Fuel Injector Removal.

CYLINDER HEAD AND CYLINDER HEAD COMPONENTS REMOVAL (Contd)

CYLINDER HEAD

1. Scribe a locating mark (6) on cylinder head (7) and cylinder block (8) before removal.

NOTE

Perform step 2 if removing front and rear cylinder head.

2. Remove four screws (3), fuel crossover connection (2), and four O-rings (1) from cylinder head (7). Discard O-rings (1).

NOTE

Perform step 3 if removing center cylinder head.

3. Remove eight screws (3), two fuel crossover connections (2), and eight O-rings (1) from center cylinder head (7). Discard O-rings (1).
4. Remove twelve bolts (5) and washers (4) in sequence (9) securing cylinder head (7) to cylinder block (8).
5. Remove cylinder head (7) and gasket (10) from cylinder block (8). Discard gasket (10).
6. Repeat steps 1 through 5 for remaining cylinder heads (7).
7. For cylinder head repair (7), refer to WP 0014 00.

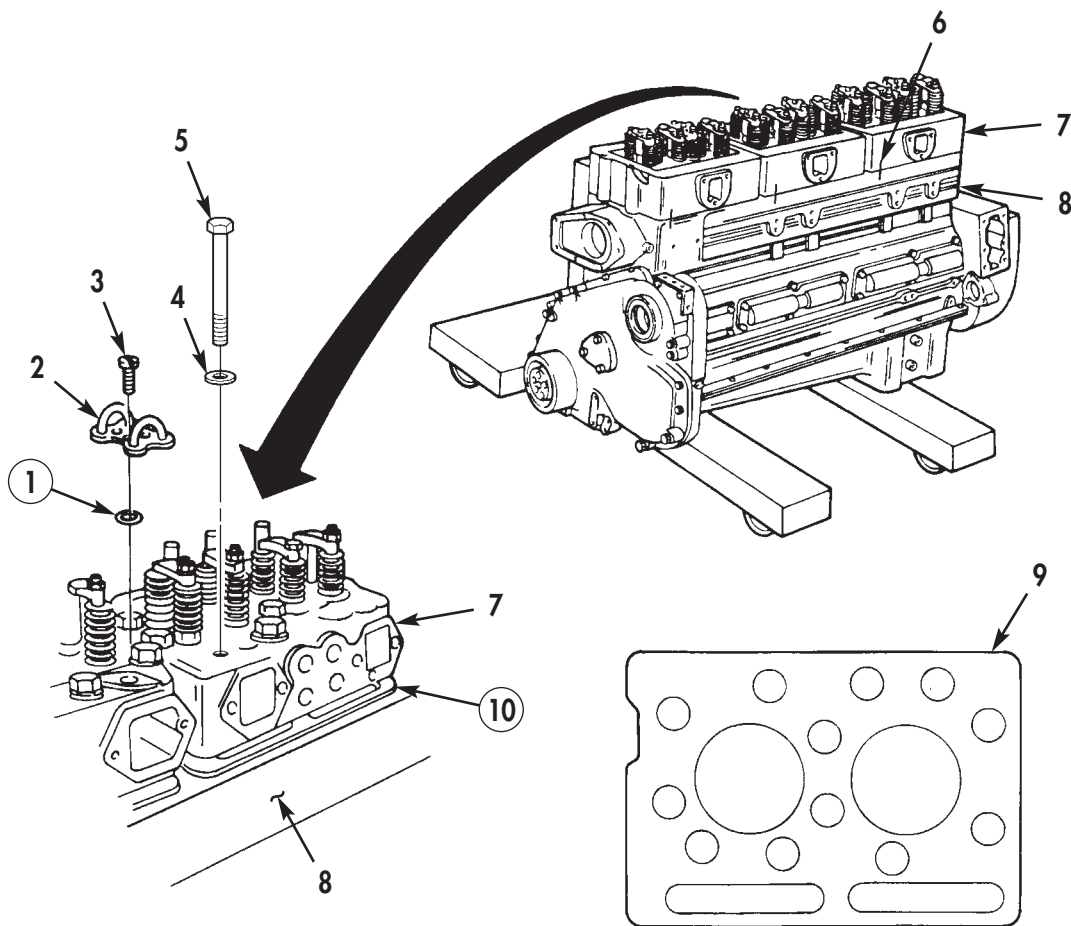


Figure 5. Cylinder Head Removal.

END OF WORK PACKAGE

**DIRECT SUPPORT AND GENERAL SUPPORT
MAINTENANCE MANUAL
INCLUDING REPAIR PARTS AND SPECIAL TOOLS LIST (RPSTL)**

FOR

M915, M915A1, M915A4, M916, M920 VEHICLES

NSN 2815-01-082-8125	P/N NTC400-3652-02	CUMMINS NTC-400 BIG CAM I DIESEL ENGINE W/CONTAINER
NSN 2815-01-142-2745	P/N 11669835	CUMMINS NTC-400 BIG CAM III DIESEL ENGINE W/CONTAINER

CYLINDER BLOCK COMPONENTS REMOVAL

**FLYWHEEL, FLEXPLATE, AND FLYWHEEL HOUSING; OIL PAN; FRONT GEAR COVER; PISTONS AND
CONNECTING RODS; CAMSHAFT FOLLOWERS; CRANKSHAFT AND MAIN BEARINGS**

INITIAL SETUP:

Tools and Special Tools

General mechanic's tool kit: automotive
(Item 1, WP 0061 00)
Maintenance and repair shop equipment:
automotive (Item 2, WP 0061 00)
Automotive maintenance and repair
supplemental set no. 2 (Item 3, WP 0061 00)
Stud 5/8-18x6 in.
Jack screw 1/2-13x6 in.
Camshaft pilot tool (Item 62, WP 0061 00)
Main bearing cap puller (Item 68, WP 0061 00)
Lifting device

Equipment Condition

Engine mounted on maintenance stand
(WP 0009 00).
Engine accessories removed (WP 0010 00).
Cylinder heads removed (WP 0011 00).

Personnel Required

Two Assistants

CYLINDER BLOCK COMPONENTS REMOVAL (Contd)

FLYWHEEL, FLEXPLATE, AND FLYWHEEL HOUSING

WARNING

Use extreme care when handling heavy parts. Provide adequate support and use assistance during procedure. Ensure that any lifting device used is in good operating condition and of suitable load capacity. Keep clear of heavy components supported only by lifting device. Failure to do so may result in death or injury to personnel.

NOTE

Big Cam I engines are equipped with a wet flywheel housing which is sealed with O-rings between cylinder block and flywheel housing.

Perform steps 1 through 5 for Big Cam I engine.

1. Remove six bolts (16) and washers (15) from flywheel (12).
2. Install two studs (17) in opposite holes on crankshaft (19).
3. Install two jack screws (18) in opposite threaded holes in flywheel (12).
4. Alternately tighten jack screws (18) and remove flywheel (12) from crankshaft (19).
5. Remove two studs (17) from crankshaft (19) and two jack screws (18) from flywheel (12).
6. Remove two bolts (25), lockwashers (27), washers (26), and nuts (28) from flywheel housing (8). Discard lockwashers (27).
7. Remove four short bolts (24) and washers (23) from flywheel housing (8).
8. Remove nine long bolts (10) and washers (9) from flywheel housing (8).
9. Remove flywheel housing (8) from cylinder block (1).

NOTE

Perform steps 10 through 12 for Big Cam I engine.

10. Remove eleven O-rings (7) from flywheel housing (8). Discard O-rings (7).
11. Remove twelve bolts (14), washers (13), and spacer gear (11) from flywheel (12).
12. Remove O-ring (6) from crankshaft (19). Discard O-ring (6).

NOTE

Perform steps 13 and 14 for Big Cam III engine.

13. Remove six bolts (32), washers (31), washer bearing (30), flywheel (12) and flexplates (33), and retaining plate (29) from crankshaft (19).
14. Remove four bolts (20), lockwashers (21), and washers (22) from rear cover (3). Discard lockwashers (21).
15. Remove eight bolts (4), rear cover (3), and gasket (2) from cylinder block (1). Discard gasket (2).
16. Remove rear main seal (5) from rear cover (3). Discard rear main seal (5).
17. For flywheel and flywheel housing repair, refer to WP 0017 00.

CYLINDER BLOCK COMPONENTS REMOVAL (Contd)

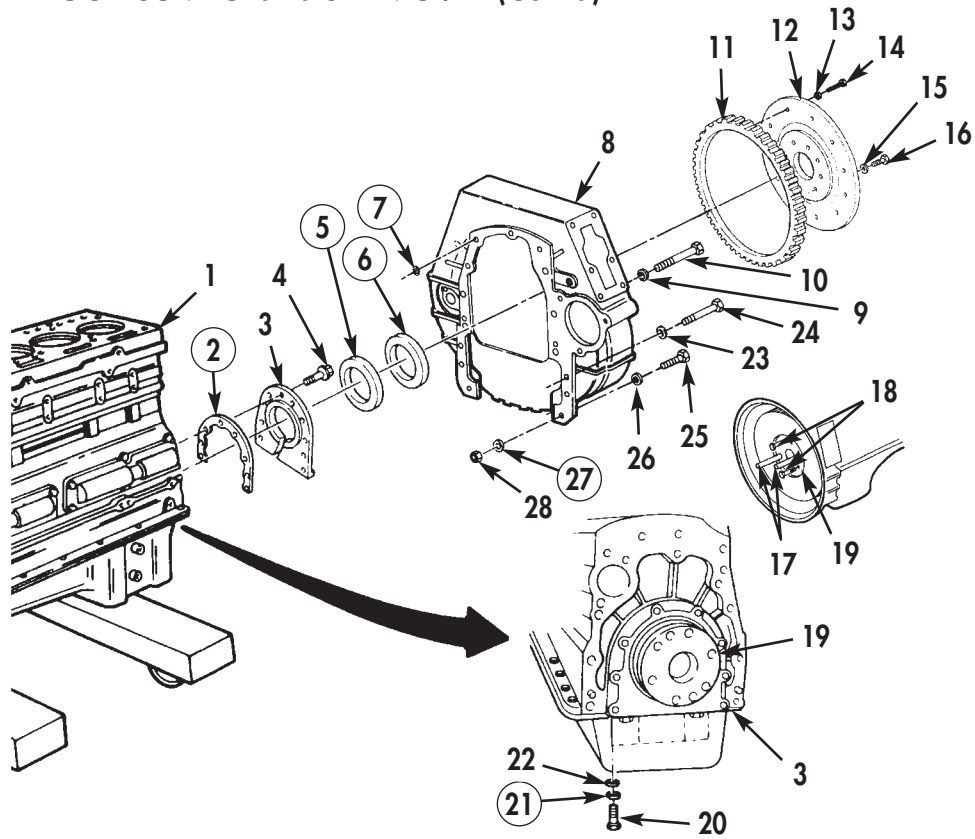


Figure 1. Flexplate and Flywheel Removal (Big Cam I).

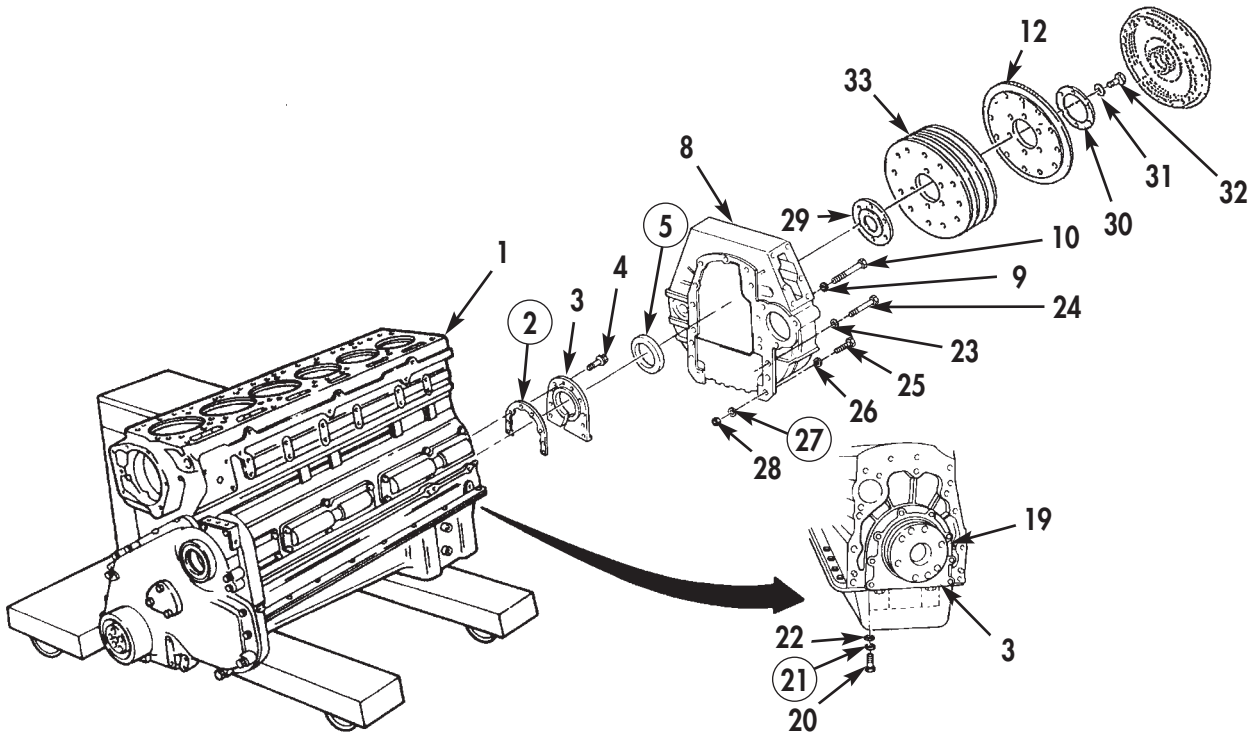


Figure 2. Flexplate and Flywheel Removal (Big Cam III).

CYLINDER BLOCK COMPONENTS REMOVAL (Contd)

OIL PAN

NOTE

Removal procedures are the same for Big Cam I and Big Cam III. Both oil pans are shown in Figure 3.

Rotate engine on maintenance stand so the oil pan is facing up.

1. Remove four bolts (10) and engine shipping support (9) from oil pan (4).
2. Remove four bolts (7), lockwashers (6), and washers (5) from rear of oil pan (4). Discard lockwashers (6).
3. Remove twenty-eight bolts (8), oil pan (4), and gasket (3) from cylinder block (2). Discard gasket (3).
4. Remove four bolts (12) securing front of oil pan (1) to cylinder block (2).
5. Remove four bolts (7), lockwashers (6), and washers (5) from rear of oil pan (1). Discard lockwashers (6).
6. Remove twenty-eight bolts (11), oil pan (1), and gasket (3) from cylinder block (2). Discard gasket (3).
7. For oil pan repair, refer to WP 0022 00.

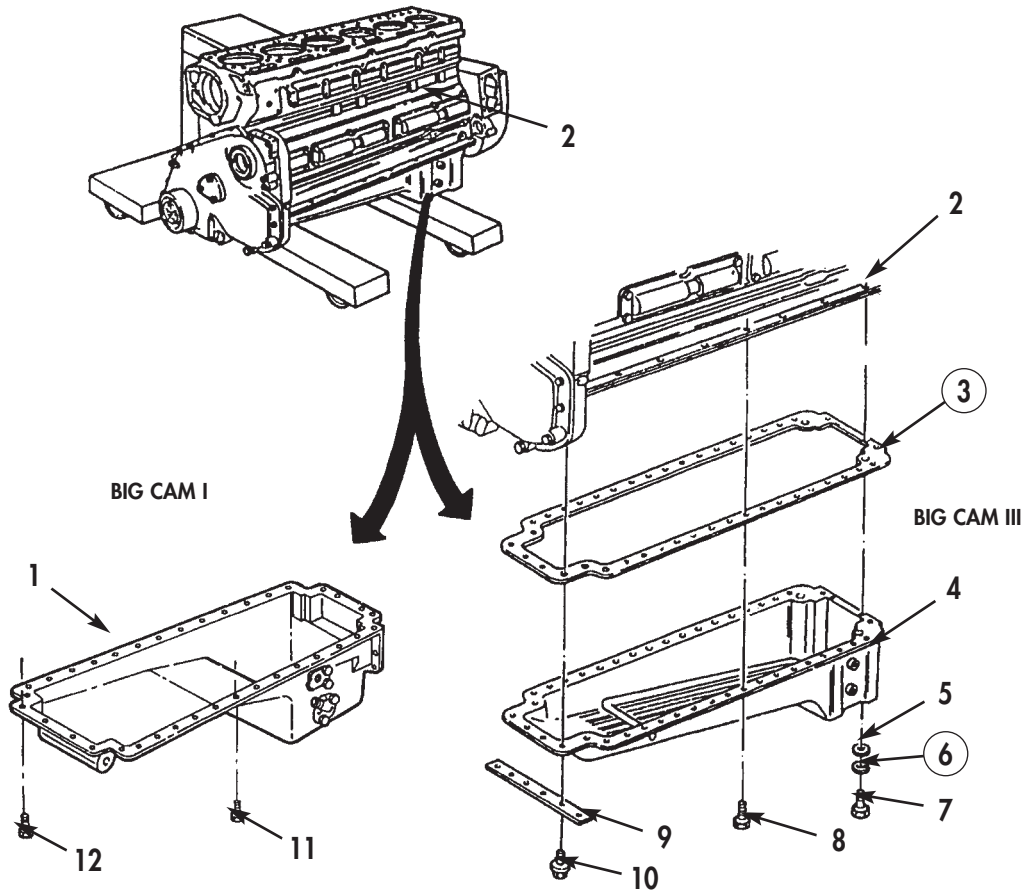


Figure 3. Oil Pan Removal.

CYLINDER BLOCK COMPONENTS REMOVAL (Contd)

FRONT GEAR COVER

1. Remove six short bolts (13) and washers (14) from front engine support (15).
2. Remove two long bolts (27), washers (28), and front engine support (15) from front gear cover (23).

NOTE

Perform steps 3 and 4 for Big Cam I engine.

3. Remove three screws (16), lockwashers (29), washers (30), camshaft support (17), shim pack (18), and O-ring (19) from front gear cover (23). Discard O-ring (19) and lockwashers (29).
4. Remove two screws (20), lockwashers (21), and washers (22) from front gear cover (23). Discard lockwashers (21).

NOTE

Perform steps 5 and 6 for Big Cam III engine.

5. Remove three captive washer screws (16), camshaft support (17), shim pack (18), and O-ring (19) from front gear cover (23). Discard O-ring (19).
6. Remove two captive washer screws (20) from front gear cover (23).
7. Remove nine captive washer screws (26) and one captive washer screw (25) from front gear cover (23).
8. Remove front gear cover (23) and gasket (24) from cylinder block (2). Discard gasket (24).

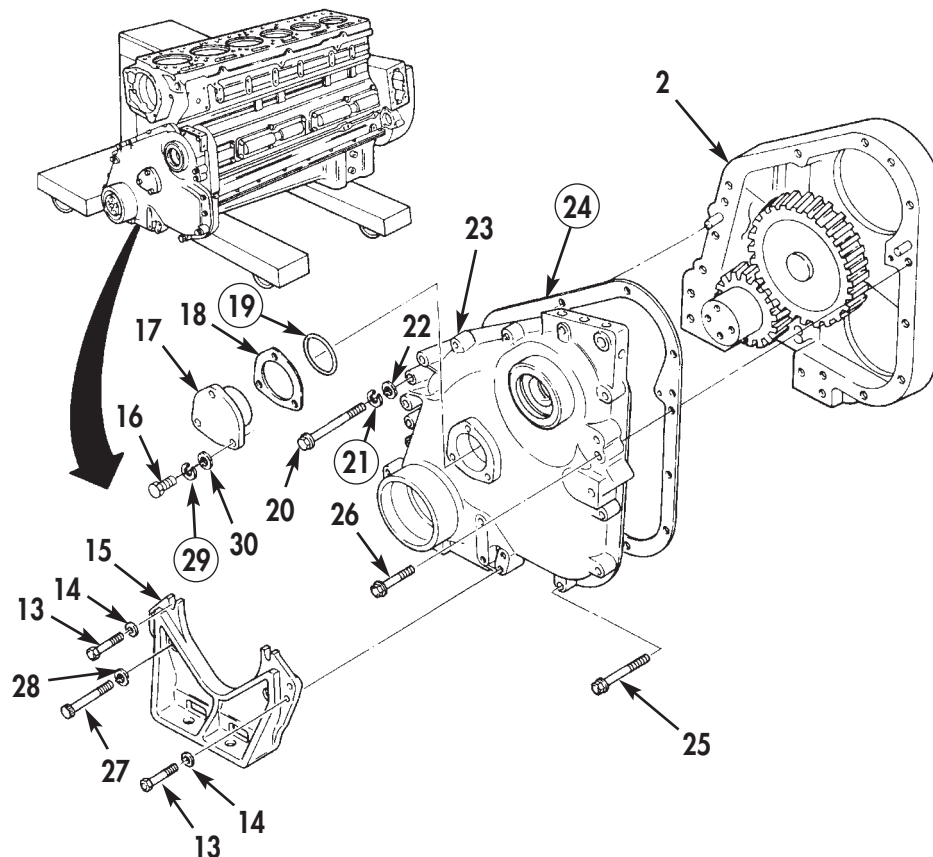


Figure 4. Front Gear Cover Removal.

CYLINDER BLOCK COMPONENTS REMOVAL (Contd)

PISTONS AND CONNECTING RODS

1. Place cylinder block (7) in a vertical position with rear of cylinder block (7) facing down.

WARNING

Eye protection must be worn when using wire brush for cleaning. Failure to do so may result in injury to personnel.

2. Using a rotary wire brush or aluminum bladed scraper, remove carbon deposits from upper inside of cylinder walls (3).
3. Rotate crankshaft (8) until connecting rod cap (6) is accessible.

NOTE

Ensure connecting rod cap and connecting rod are identified together by cylinder number. Mark cylinder number and the Letter L on flat surfaces of connecting rod cap and connecting rod before removal.

4. Loosen two connecting rod bolts (5) until there is approximately 3/8 in. (9.5 mm) clearance between head of bolts (5) and connecting rod cap (6).
5. Using a soft-faced hammer, tap on head of bolts (5) until connecting rod cap (6) and connecting rod (1) are separated.
6. Remove bolts (5) and connecting rod cap (6) from connecting rod (1) and crankshaft (8).
7. Install two nylon guide screws (4) in connecting rod (1).
8. Push piston (2) and connecting rod (1) out of cylinder liner (3).
9. Remove two nylon guide screws (4) from connecting rod (1).
10. Repeat steps 1 through 9 to remove remaining five connecting rod caps (6), connecting rods (1), and pistons (2).
11. For piston and connecting rod repair, refer to WP 0018 00.

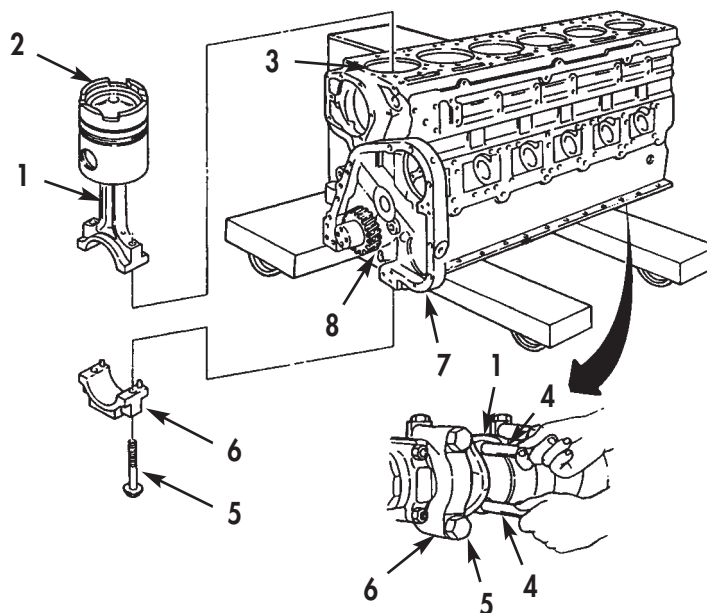


Figure 5. Piston and Connecting Rod Removal.

CYLINDER BLOCK COMPONENTS REMOVAL (Contd)

CAMSHAFT FOLLOWERS

NOTE

Scribe locating mark on cam follower and cylinder block before removal.

1. Remove six screws (13) and lockwashers (14) from cam follower (12). Discard lockwashers (14).
2. Remove cam follower (12), and gasket (11) from cylinder block (10).

NOTE

Measuring thickness of gasket for each cam follower is required for correct timing of injectors due to individual differences between castings.

3. Using a micrometer, measure gasket (11) at three points (A), (B), and (C) and record average thickness. Discard gasket (11) when all measurements have been taken and recorded.
4. Repeat steps 1 through 3 to remove remaining cam followers (12).

CAUTION

Use extreme care when removing camshaft or damage to camshaft bushings may occur.

5. Install four camshaft pilot tools on front of camshaft (9).
6. Using camshaft pilot tools, slowly turn camshaft (9) and remove camshaft (9) from cylinder block (10).
7. Remove camshaft pilot tools from camshaft (9).
8. For camshaft repair, refer to WP 0019 00.

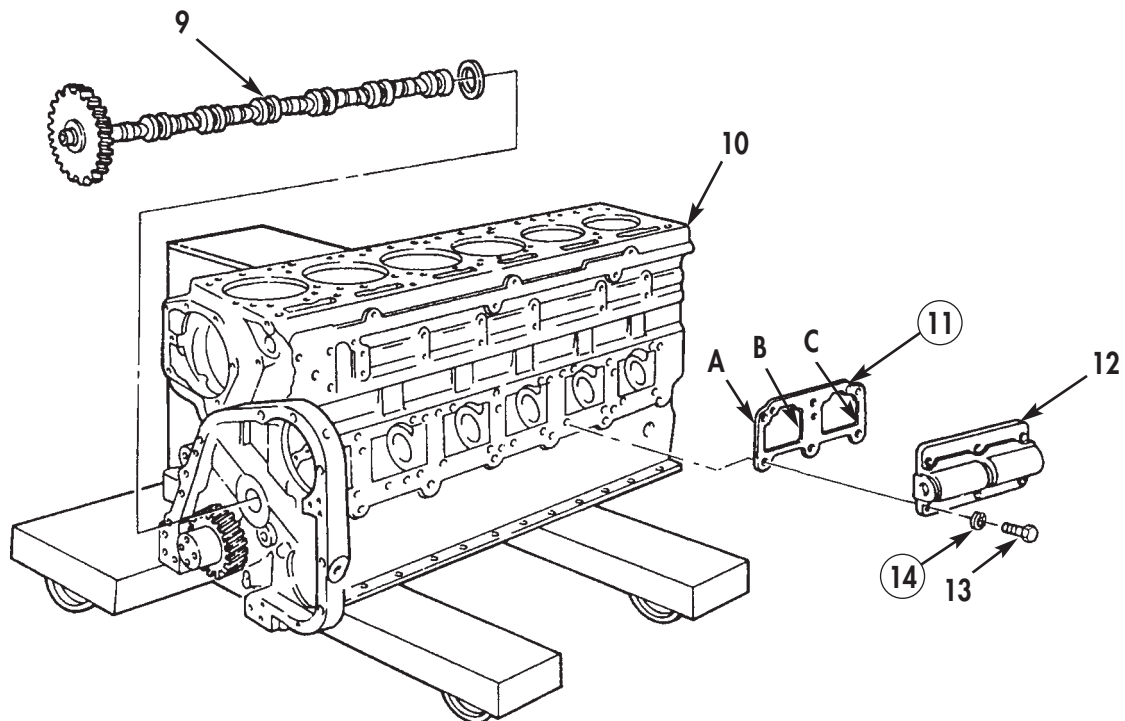


Figure 6. Camshaft and Camshaft Followers Removal.

CYLINDER BLOCK COMPONENTS REMOVAL (Contd)

CRANKSHAFT AND MAIN BEARINGS

CAUTION

Cylinder block and main bearing caps are line bored. Mark all main bearing caps to their position in the cylinder block before removal to ensure correct assembly. Installing a main bearing cap in the wrong position will cause damage to the engine.

1. Bend tabs on fourteen locking plates (7) down.
2. Remove fourteen bolts (6) and locking plates (7) from seven main bearing caps (3). Discard locking plates (7).
3. Using main bearing cap puller, remove seven main bearing caps (3), main bearing halves (4), and retaining rings (5) from cylinder block (1).

NOTE

Ensure hooks on chain are covered with rubber hose or equivalent to prevent damage to crankshaft.

4. Using lifting device, remove crankshaft (2) from cylinder block (1).
5. For crankshaft repair, refer to WP 0016 00.
6. For cylinder block repair, refer to WP 0013 00.

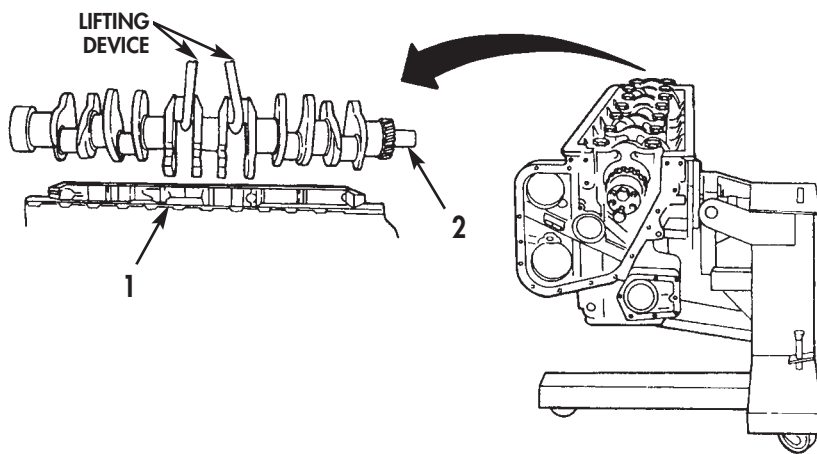


Figure 7. Crankshaft Removal.

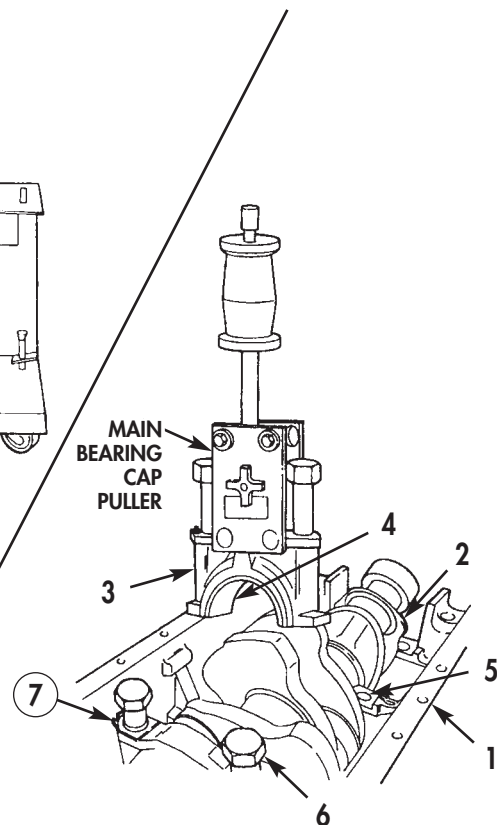


Figure 8. Main Bearings Removal.

END OF WORK PACKAGE

**DIRECT SUPPORT AND GENERAL SUPPORT
MAINTENANCE MANUAL
INCLUDING REPAIR PARTS AND SPECIAL TOOLS LIST (RPSTL)**

FOR

M915, M915A1, M915A4, M916, M920 VEHICLES

NSN 2815-01-082-8125	P/N NTC400-3652-02	CUMMINS NTC-400 BIG CAM I DIESEL ENGINE W/CONTAINER
NSN 2815-01-142-2745	P/N 11669835	CUMMINS NTC-400 BIG CAM III DIESEL ENGINE W/CONTAINER

**CYLINDER BLOCK
DISSASSEMBLY, CLEANING AND INSPECTION, ASSEMBLY**

INITIAL SETUP:

Tools and Special Tools

General mechanic's tool kit: automotive
(Item 1, WP 0061 00)
Maintenance and repair shop equipment:
automotive (Item 2, WP 0061 00)
Automotive maintenance and repair
supplemental set no. 2 (Item 3, WP 0061 00)
Cylinder sleeve driver (Item 47, WP 0061 00)
Cylinder sleeve clamp (Item 48, WP 0061 00)
Gauge block (Item 49, WP 0061 00)
Engine block counterbore tool
(Item 50, WP 0061 00)
Universal cylinder sleeve puller
(Item 52, WP 0061 00)

Materials/Parts (Contd)

Two expansion plugs
(Item 7, Table 1, WP 0062 00)
Six shims (Item 8, Table 1, WP 0062 00)

Equipment Condition

Engine mounted on maintenance stand
(WP 0009 00).
Cylinder block disassembled (WP 0012 00).

Materials/Parts

Oil, lubricating, OE/HDO 10
(Item 19, WP 0060 00)
Cloth, emery, 290-grit (Item 5, WP 0060 00)
Sealant, pipe (Item 25, WP 0060 00)
Six gaskets (Item 1, Table 1, WP 0062 00)
Six black O-rings (Item 2, Table 1, WP 0062 00)
Six red O-rings
(Item 3, Table 1, WP 0062 00)
Four expansion plugs
(Item 4, Table 1 WP 0062 00)
Expansion plug (Item 5, Table 1, WP 0062 00)
Cap (Item 6, Table 1, WP 0062 00)

CYLINDER BLOCK (Contd)

DISASSEMBLY

NOTE

Rotate the engine so cylinder sleeves are facing up. All cylinder sleeves are removed the same way. The following procedure covers one cylinder sleeve.

1. Using universal cylinder sleeve puller, remove cylinder sleeve (1) from cylinder block (11).

NOTE

If shims are used under cylinder sleeve, do not discard shims. Using a micrometer or equivalent, measure and record thickness of six shims and tag the location of each cylinder sleeve and shims to aid in assembly.

2. Remove red O-ring (4), black O-ring (5), gasket (3) and shims (2) from cylinder sleeve (1). Discard red O-ring (4), black O-ring (5), and gasket (3).
3. Perform steps 1 and 2 for remaining cylinder sleeves.
4. Remove sixteen expansion plugs (6) from cylinder block (11). Discard expansion plugs (6).
5. Remove expansion plug (9) and washer (10) from cylinder block (11). Discard expansion plug (9).
6. Remove six dowel pins (12) from cylinder block (11).
7. Remove six cam follower dowel pins (8) from cylinder block (11).
8. Using hammer and punch, remove cap (7) from cylinder block (11). Discard cap (7).

CLEANING AND INSPECTION

1. For general parts cleaning information, refer to CLEANING, WP 0051 00.
2. For general parts inspection information, refer to INSPECTION, WP 0051 00.

NOTE

Replace any part that does not pass visual inspection or that is outside specified wear limits.

Cylinder block must be checked on a flat surface to prevent distortion and incorrect measurements.

Do not inspect cylinder block on maintenance stand.

3. Using crack detector dye, inspect cylinder sleeves (1) and cylinder block (11) for cracks.
4. Inspect cylinder sleeves (1) for excessive corrosion, erosion, and pits. Maximum pit depth is .0625 in. (1.6 mm).
5. Inspect underside top flange of cylinder sleeves (1) for dents, pitting, or worn surfaces. If surface cannot be smoothed out with 290-grit emery cloth, discard cylinder sleeve (1).
6. Using dial bore gauge, measure inside bore of cylinder sleeve (1). Maximum inside diameter is 5.505 in. (13.983 cm).
7. Inspect all cylinder block (11) plug holes and threaded holes for damaged threads and surfaces.
8. Inspect all dowel pins (8) and (12) for cracks or distortion.
9. Using straightedge and 0.02 in. (0.51 mm) feeler gauge, check cylinder block (11) for flatness. If gap between straightedge and cylinder block (10) is more than 0.02 in. (0.51 mm), cylinder block (11) must be milled.

CYLINDER BLOCK (Contd)

CLEANING AND INSPECTION (Contd)

10. Inspect cylinder liner counterbore of cylinder block (10) for dirty or rough edges.

NOTE

Counterbore diameter must be measured in liner press fit area 0.100 in. (2.54 mm) maximum below deck. Repair and shim cylinder liner counterbore if the following conditions are not met.

11. Using engine block counterbore tool, measure inside diameter and depth of counterbore at four equally spaced positions. Difference in measurement around circumference must not exceed 0.001 in. (0.0254 mm).

NOTE

When checking cylinder liner protrusion, ensure shim(s) and cylinder sleeve correspond to cylinder being inspected as tagged during removal.

Cylinder sleeve shims are available in the following thicknesses: 0.007 in. (0.178 mm), 0.008 in. (0.203 mm), 0.009 in. (0.229 mm), 0.020 in. (0.508 mm), 0.031 in. (0.787 mm), and 0.062 in. (1.575 mm).

Cylinder liner counterbore depth is 0.412 in. (10.465 mm).

12. Using depth micrometer, measure depth of cylinder sleeve counterbore of cylinder block (11) and outside flange of cylinder sleeve (1) for corresponding cylinder. Subtract difference to determine amount of shims and/or depth of counterbore cut.

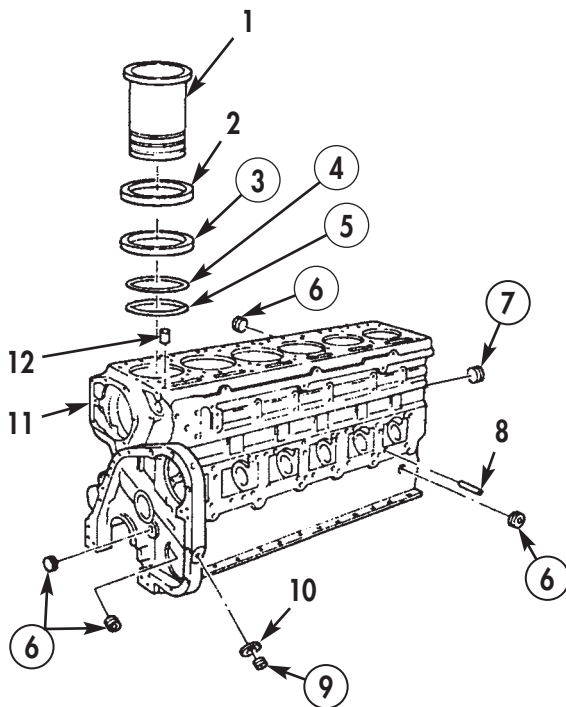


Figure 1. Cylinder Block Disassembly, Clean, and Inspect.

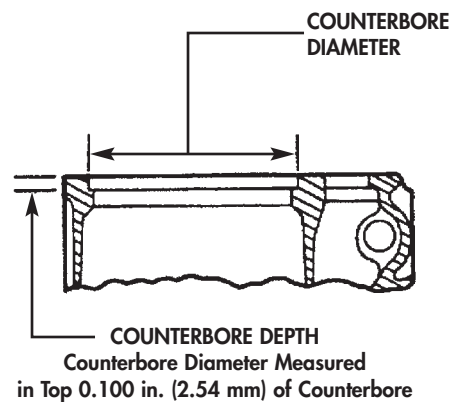


Figure 2. Cylinder Sleeve Counterbore Measurement.

CYLINDER BLOCK (Contd)

ASSEMBLY

1. Apply pipe sealant to threads of new expansion plug (6). Install expansion plug (6) on cylinder block (14). Tighten plug (6) 30 lb-ft (41 N•m).
2. Apply pipe sealant to threads of two new expansion plugs (12). Install expansion plugs (12) on cylinder block (14). Tighten expansion plugs (12) 45 lb-ft (61 N•m).
3. Apply pipe sealant to threads of four new expansion plugs (9). Install expansion plugs (9) on cylinder block (14). Tighten expansion plugs (9) 15 lb-ft (20 N•m).
4. Apply pipe sealant to threads of five new expansion plugs (13). Install expansion plugs (13) on cylinder block (14). Tighten expansion plugs (13) 35 lb-ft (48 N•m).
5. Apply pipe sealant to threads of new expansion plug (10). Install expansion plug (10) and washer (11) on cylinder block (14). Tighten expansion plug (10) 70 lb-ft (95 N•m).
6. Install cylinder sleeve shims (2), as required, on cylinder sleeve (1).
7. Install new cap (7) on cylinder block (14).

CAUTION

Do not lubricate O-rings until ready to install assembled cylinder sleeve. O-rings will increase in size once in contact with OE/HDO 10 lubricating oil for more than 10 minutes.

Prior to installing a cylinder sleeve, apply a bead of inner sealer on counterbore of cylinder sleeve flange. Do not use an excessive amount of sealer. Excessive amounts can cause problems in cooling system.

Do not permit lubricating oil, once applied to O-rings, to come in contact with liner sealant. Oil will prevent sealant from adhering to liner flange and counterbore contact surface.

NOTE

Diameter of applied sealer bead must be at least 3/64 in. (1.2 mm) and not more than 1/16 in. (1.6 mm) wide. Cylinder sleeve must be installed within 5 minutes after sealer has been applied.

All cylinder sleeves are installed the same way. The following procedure covers one cylinder liner installation.

8. Install new gasket (3) with chamfer down in top groove on cylinder sleeve (1).
9. Install new black O-ring (5) on center groove of cylinder sleeve (1).
10. Install new red O-ring (4) on bottom groove of cylinder sleeve (1).
11. Apply OE/HDO 10 lubricating oil to gasket (3) and O-rings (4) and (5) and install assembled cylinder sleeve (1) on cylinder block (15) within 10 minutes.
12. Position cylinder sleeve (1) on bore of cylinder block (14) by hand and push downward with one quick stroke.
13. Using cylinder sleeve driver and mallet, drive flange against counterbore edge.
14. Install two cylinder sleeve clamps on cylinder block (14) and cylinder sleeve (1). Tighten clamps 50 lb-ft (68 N•m).
15. Using gauge block, check protrusion of cylinder sleeve (1). Amount of protrusion must not exceed 0.003–0.006 in. (0.076–0.152 mm).
16. Remove cylinder sleeve clamps from cylinder block (14) and cylinder sleeve (1).
17. Repeat steps 7 through 15 for remaining cylinder sleeves.

CYLINDER BLOCK (Contd)

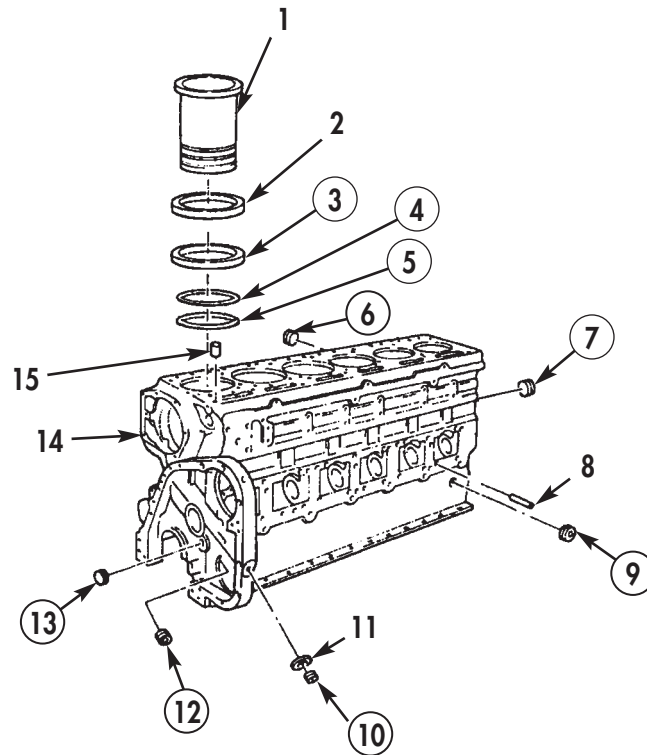


Figure 3. Cylinder Block Assembly.

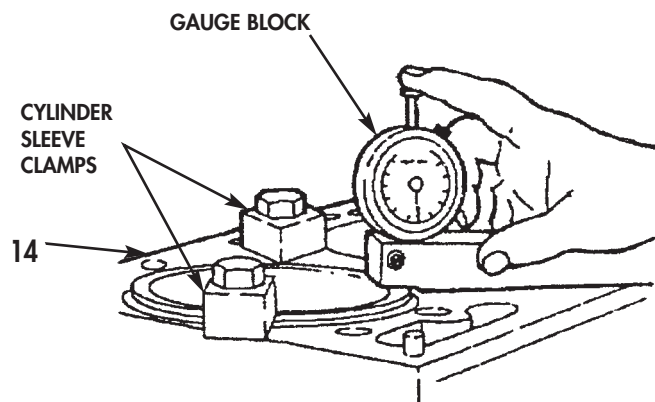


Figure 4. Measuring Cylinder Sleeve Protrusion.

**DIRECT SUPPORT AND GENERAL SUPPORT
MAINTENANCE MANUAL
INCLUDING REPAIR PARTS AND SPECIAL TOOLS LIST (RPSTL)**

FOR

M915, M915A1, M915A4, M916, M920 VEHICLES

NSN 2815-01-082-8125	P/N NTC400-3652-02	CUMMINS NTC-400 BIG CAM I DIESEL ENGINE W/CONTAINER
NSN 2815-01-142-2745	P/N 11669835	CUMMINS NTC-400 BIG CAM III DIESEL ENGINE W/CONTAINER

CYLINDER HEAD

DISASSEMBLY, CLEANING AND INSPECTION, ASSEMBLY

INITIAL SETUP:

Tools and Special Tools

General mechanic's tool kit: automotive
(Item 1, WP 0061 00)
Maintenance and repair shop equipment:
automotive (Item 2, WP 0061 00)
Automotive maintenance and repair
supplemental set no. 2 (Item 3, WP 0061 00)
Valve spring compressor
(Item 53, WP 0061 00)
Valve seat extractor (Item 54, WP 0061 00)
Expansion plug driver (Item 55, WP 0061 00)
Valve vacuum tester (Item 56, WP 0061 00)

Materials/Parts

Lubricating oil (Item 19, WP 0060 00)
Liquid thread sealant (Item 26, WP 0060 00)
Twenty-four valve spring retainers
(Item 1, Table 2, WP 0062 00)
Twenty-four valve springs
(Item 2, Table 2, WP 0062 00)
Twenty-four valve spring retainers
(Item 3, Table 2, WP 0062 00)
Six injector O-rings
(Item 4, Table 2, WP 0062 00)
Six expansion plugs
(Item 5, Table 2, WP 0062 00)
Twenty-four valve seat inserts
(Item 6, Table 2, WP 0062 00)
Twelve intake valves
(Item 7, Table 2, WP 0062 00)

Materials/Parts (Contd)

Twelve exhaust valves
(Item 8, Table 2, WP 0062 00)
Expansion plug
(Item 9, Table 2, WP 0062 00)
Two expansion plugs
(Item 10, Table 2, WP 0062 00)
Twenty-four valve stem guides
(Item 11, Table 2, WP 0062 00)
Locknut (Item 12, Table 2, WP 0062 00)
Twelve O-rings (Item 13, Table 2, WP 0062 00)

Equipment Condition

Engine crankshaft and main bearings removed
(WP 0012 00).

CYLINDER HEAD (Contd)

DISASSEMBLY

1. Remove locknut (23) and adjusting screw (24) from exhaust valve crosshead (22). Discard locknut (23).
2. Remove exhaust valve crosshead (22) and crosshead guide (21) from cylinder head (25).

NOTE

All intake and exhaust valves are removed the same. The following procedure covers removal of one exhaust valve.

3. Using valve spring compressor, compress exhaust valve spring (4).

NOTE

It may be necessary to tap valve lightly to loosen it.

4. Remove two valve collets (2) from exhaust valve (15).

NOTE

If spacers are used, cylinder head has been resurfaced previously.

5. Remove exhaust valve (15), spring retainer (3), valve spring (4), and spacer (5), if used, from cylinder head (25). Discard exhaust valve (15), valve spring (4), retainer (3), and spacer (5).
6. Remove valve stem guide (6) from cylinder head (25). Discard valve stem guide (6).
7. Using valve seat extractor, remove valve seat insert (14) from cylinder head (25). Discard valve seat insert (14).
8. Perform steps 1 through 7 for remaining exhaust and intake valves.
9. Using injector sleeve puller, remove two injector sleeves (8) and injector O-rings (7) from cylinder head (25). Discard injector O-rings (7).
10. Remove two screws (20), cover plate (19), and two O-rings (18) from cylinder head (25). Discard O-rings (18).
11. Remove four pipe plugs (17) from cylinder head (25).
12. Using hammer and punch, tap outside diameter of expansion plugs (12) and (16) to force one side out from cylinder head (25).
13. Using screwdriver, remove six expansion plugs (12), plug (16), and two plugs (26) from cylinder head (25). Discard expansion plugs (12), (16), and (26).
14. Remove four screws (9), two fuel connections (10), and four O-rings (11) from cylinder head (25). Discard O-rings (11).
15. Remove two dowels (13) from cylinder head (25).
16. Perform steps 1 through 15 for remaining cylinder heads (25).

CLEANING AND INSPECTION

1. For general parts cleaning information, refer to CLEANING, WP 0051 00.
2. For general parts inspection information, refer to INSPECTION, WP 0051 00.

NOTE

Replace any part that does not pass visual inspection or is outside specified wear limits.

3. Inspect cylinder head (25) for cracks, breaks, distortion, and broken-out areas.
4. Using straightedge and feeler gauge, inspect cylinder head (25) for distortion on mating surface. Maximum distortion is 0.002 in. (0.051 mm).

CYLINDER HEAD (Contd)

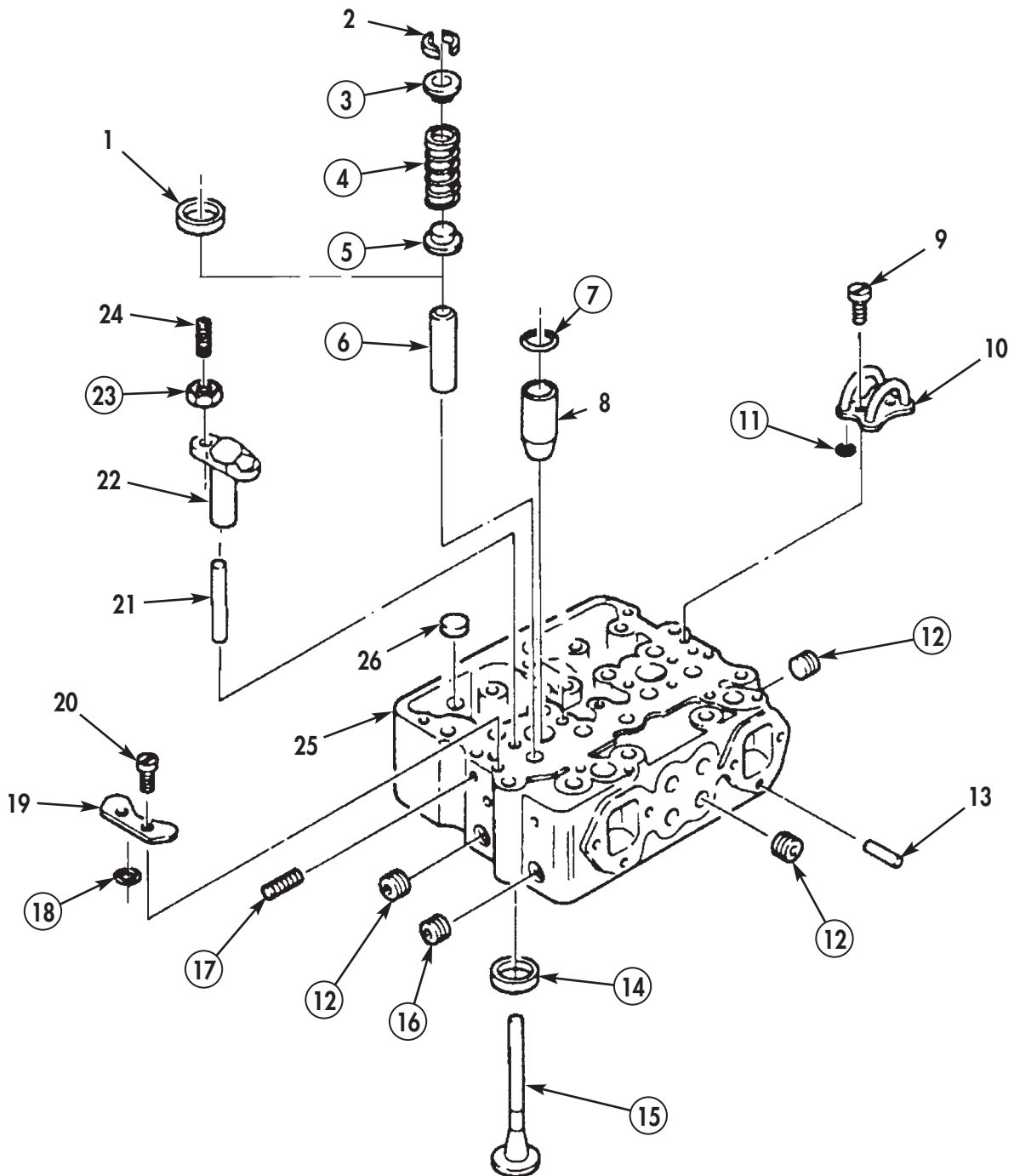


Figure 1. Cylinder Head Disassembly and Cleaning and Inspection.

CYLINDER HEAD (Contd)

CLEANING AND INSPECTION (Contd)

5. Using vernier depth gauge, measure cylinder head (25) height. Minimum cylinder head height is 4.30 in. (11.024 cm).
6. Inspect injector sleeves (8) for scratches and cracks.
7. Inspect all parts for cracking, breaking, excessive wear, or other damage.
8. Inspect all threaded parts for stripped threads or cross-threading.

ASSEMBLY

1. Apply cup plug sealant to six new expansion plugs (12), new plug (16), and two new plugs (26), and to inside diameter of water holes on cylinder head (25).
2. Using expansion plug driver, install expansion plugs (12), (16), and (26) on cylinder head (25).

NOTE

Step 3 does not apply to No. 2 cylinder head.

3. Apply clean lubricating oil to two new O-rings (18). Install cover plate (19) and O-rings (18) on cylinder head (25) with two screws (20).

NOTE

All intake and exhaust valves are installed the same. The following procedure covers installation of one exhaust valve.

4. Using valve seat inserter, install new valve seat insert (14) on cylinder head (25).
5. Using valve stem guide driver, install new valve stem guide (6) on cylinder head (25).
6. Apply clean lubricating oil to new exhaust valve (15) and install exhaust valve (15) on new valve stem guide (6) from bottom side of cylinder head (25).
7. Place cylinder head (25) on protective surface with machined surface down.
8. Install new spacer (5), if necessary, new valve spring (4), and new retainer (3) over valve stem guide (6) on cylinder head (25).

NOTE

Stud of valve spring compressor should be installed on rocker lever screw hole.

9. Using valve spring compressor, compress valve spring (4) and install valve collet (2) on stem of valve (15).
10. Using valve vacuum tester, check seal between valve (15) and valve seat (14).
11. Install two adjusting screws (24) and new locknuts (23) on exhaust valve crosshead (22).
12. Install exhaust valve crosshead (22) and crosshead guide (21) on cylinder head (25).
13. Perform steps 4 through 12 for remaining intake and exhaust valves.
14. Apply clean lubricating oil to new O-ring (11). Install screw (9), fuel connection (10), and O-ring (11) on cylinder head (25).
15. Apply clean lubricating oil to new O-rings (7). Using injector sleeve driver, install injector sleeve (8) and injector O-ring (7) on cylinder head (25).
16. Apply clean lubricating oil to eleven dowels (13), and install eleven dowels (13) on cylinder head (25).
17. Apply liquid thread sealant to four pipe plugs (17), and install pipe plugs (17) on cylinder head (25).

CYLINDER HEAD (Contd)

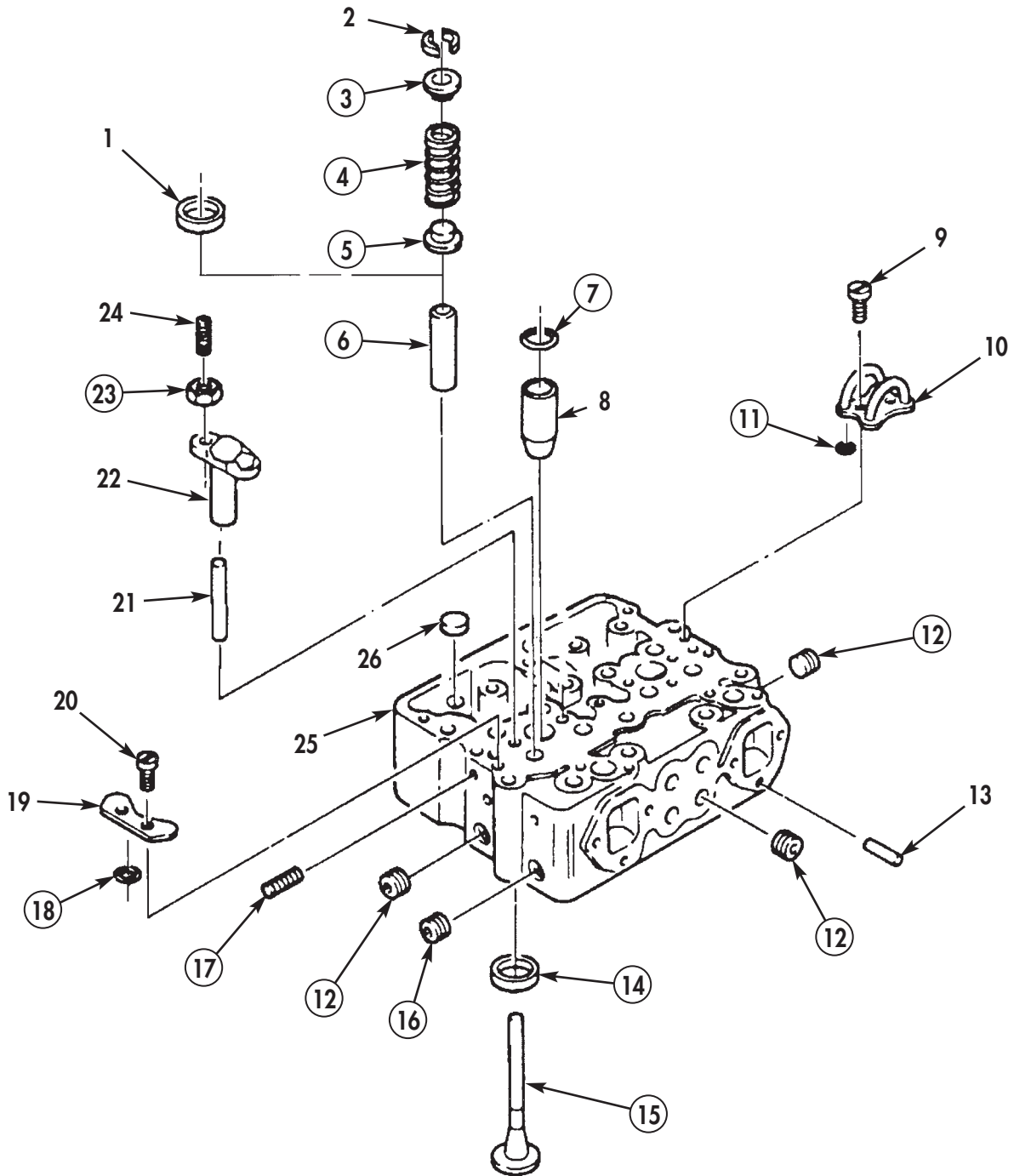


Figure 2. Cylinder Head Assembly.

CYLINDER HEAD (Contd)**NOTE**

Step 18 is for Big Cam I engines only.

18. Tighten pipe plugs (17) as shown in table 1.
19. Perform steps 1 through 18 for remaining cylinder heads (25).

Table 1. Pipe Plugs Torque Specifications.

PIPE PLUG SIZE		MINIMUM		MAXIMUM	
INCH	(MM)	LB FT	(N•m)	LB FT	(N•m)
3/16	9.525	35	47	45	61
1/2	12.70	60	81	70	95
3/4	19	65	88	75	102
1	25	135	183	145	197

**DIRECT SUPPORT AND GENERAL SUPPORT
MAINTENANCE MANUAL
INCLUDING REPAIR PARTS AND SPECIAL TOOLS LIST (RPSTL)**

FOR

M915, M915A1, M915A4, M916, M920 VEHICLES

NSN 2815-01-082-8125	P/N NTC400-3652-02	CUMMINS NTC-400 BIG CAM I DIESEL ENGINE W/CONTAINER
NSN 2815-01-142-2745	P/N 11669835	CUMMINS NTC-400 BIG CAM III DIESEL ENGINE W/CONTAINER

VIBRATION DAMPER AND CRANKSHAFT PULLEY CLEANING AND INSPECTION

INITIAL SETUP:

Tools and Special Tools

General mechanic's tool kit: automotive
(Item 1, WP 0061 00)
Maintenance and repair shop equipment:
automotive (Item 2, WP 0061 00)
Automotive maintenance and repair
supplemental set no. 2 (Item 3, WP 0061 00)

Materials/Parts

Spotcheck developer (Item 10, WP 0060 00)
290-grit emery cloth (Item 5, WP 0060 00)

Equipment Condition

Vibration damper and crankshaft pulley
removed from engine (WP 0010 00).

VIBRATION DAMPER AND CRANKSHAFT PULLEY CLEANING AND INSPECTION (Contd)

1. For general parts cleaning information, refer to CLEANING, WP 0051 00.
2. For general parts inspection information, refer to INSPECTION, WP 0051 00.

NOTE

Replace vibration damper and crankshaft pulley if they do not pass visual inspection or are outside specified wear limits.

3. Inspect vibration damper (1) for cracks, breaks, or other damage.
4. Inspect crankshaft pulley (2) for cracks, breaks, or other damage.
5. Spray vibration damper (1) with spotcheck developer and place in preheated 200°F (93°C) oven for two hours. Remove from oven and inspect vibration damper (1) for leaks. Discard if leak is found.
6. Using 290-grit emery cloth, remove paint from four opposite corners of vibration damper (1) to measure outside diameter thickness.
7. Using micrometer or equivalent, measure vibration damper (1) outside diameter thickness at four corners. Maximum thickness is 0.125 in. (3.175 mm). Discard vibration damper (1) if any two measurements are more than 0.010 in. (0.254 mm).
8. For installation of vibration damper (1) and crankshaft pulley (2), refer to WP 0045 00.

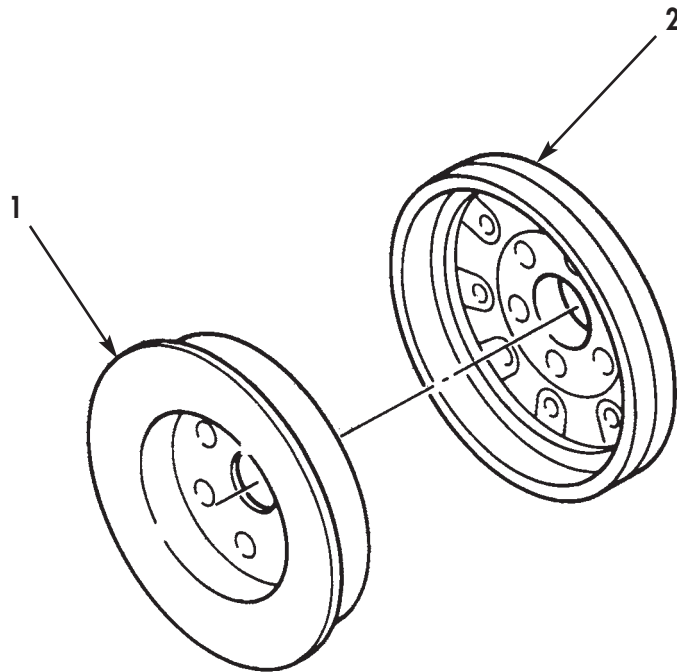
VIBRATION DAMPER AND CRANKSHAFT PULLEY CLEANING AND INSPECTION (Contd)

Figure 1. Vibration Damper and Crankshaft Pulley Inspection.

**DIRECT SUPPORT AND GENERAL SUPPORT
MAINTENANCE MANUAL
INCLUDING REPAIR PARTS AND SPECIAL TOOLS LIST (RPSTL)**

FOR

M915, M915A1, M915A4, M916, M920 VEHICLES

NSN 2815-01-082-8125	P/N NTC400-3652-02	CUMMINS NTC-400 BIG CAM I DIESEL ENGINE W/CONTAINER
NSN 2815-01-142-2745	P/N 11669835	CUMMINS NTC-400 BIG CAM III DIESEL ENGINE W/CONTAINER

CRANKSHAFT CLEANING AND INSPECTION

INITIAL SETUP:

Tools and Special Tools

General mechanic's tool kit: automotive
(Item 1, WP 0061 00)
Maintenance and repair shop equipment,
automotive (Item 2, WP 0061 00)
Automotive maintenance and repair
supplemental set no. 2 (Item 3, WP 0061 00)

Equipment Condition

Engine crankshaft and main bearings removed
(WP 0012 00).

CRANKSHAFT CLEANING AND INSPECTION (Contd)

1. For general parts cleaning information, refer to CLEANING, WP 0051 00.
2. For general parts inspection information, refer to INSPECTION, WP 0051 00.

NOTE

Replace any part that does not pass visual inspection or is outside specified wear limits.

3. Inspect crankshaft (1) for cracks, breaks, damage, or wear.
4. Inspect rear oil seal contact area (3) for wear and grooves.
5. Using vernier caliper, measure outside diameter of rear oil seal contact area (3). Minimum diameter is 5.998 in. (15.234 cm).
6. Inspect front oil seal contact area (6) for wear and grooves.
7. Using vernier caliper, measure outside diameter of front oil seal contact area (6). Minimum diameter is 3.625 in. (9.207 cm).
8. Inspect main bearing halves (8) for pits, scratches, or grooves.
9. Using micrometer, measure thickness of main bearing halves (8). Minimum thickness is 0.123 in. (3.124 mm). Maximum thickness is 0.1238 in. (3.144 mm). Wear limit is 0.1215 in. (3.0861 mm).
10. Using vernier caliper, measure rod bearing journal (5) diameter at three and six o'clock positions. Minimum diameter is 3.124 in. (7.933 cm).
11. Using vernier caliper, measure main bearing journal (4) diameter. Minimum diameter is 4.489 in. (11.426 cm).

NOTE

Prior to measuring thrust ring thickness, place crankshaft on cylinder block with corresponding bearing halves and caps installed.

12. Measure thickness of each thrust ring (9) at different locations. Minimum thrust ring (9) thickness is 0.245 in. (6.223 mm). If endplay clearance exceeds 0.022 in. (0.559 mm), install oversize thrust rings.
13. Inspect two thrust ring pins (10) for damage or wear.
14. Inspect seven retaining rings (11) for wear, out-of-round, or cracks.
15. Inspect crankshaft gear (7) for worn, cracked, or broken gear teeth.
16. Inspect crankshaft gear (7) for loose or worn keyway.
17. Inspect crankshaft keyway (13) for looseness, wear, or damage.
18. Using vernier caliper, measure width of keyway (13). Maximum width is 0.375 in. (9.525 mm).
19. Inspect crankshaft gear step (12) for wear, grooves, or damage.
20. Using vernier caliper, measure outside diameter of crankshaft gear step (12). Minimum diameter is 3.761 in. (9.552 cm).

NOTE

Perform steps 21 and 22 for Big Cam I engine only.

21. Using vernier caliper, measure crankshaft thrust flange (4). Wear greater than 0.003 in. (0.076 mm) requires regrinding to restore flatness.

CRANKSHAFT CLEANING AND INSPECTION (Contd)

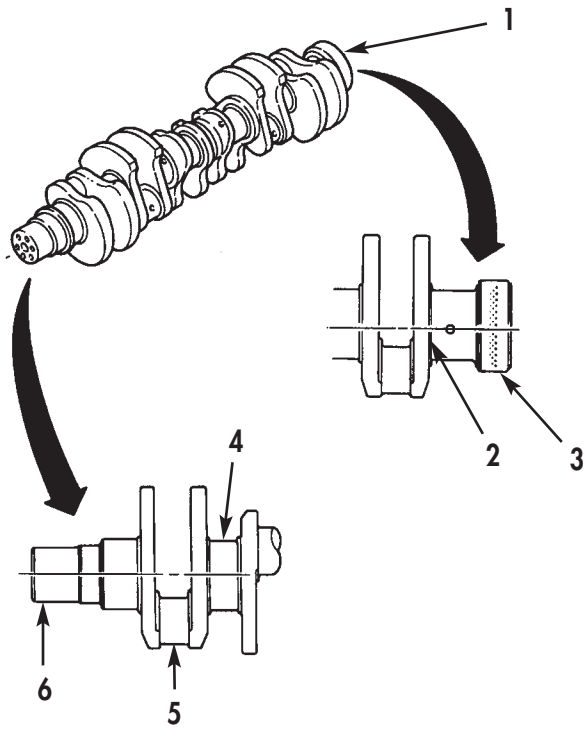


Figure 1. Crankshaft Cleaning and Inspection.

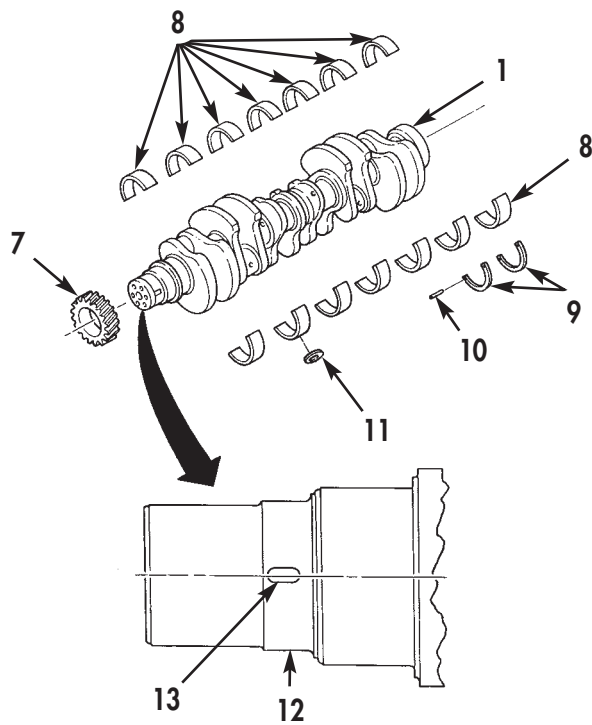


Figure 2. Crankshaft Cleaning and Inspection.

CRANKSHAFT CLEANING AND INSPECTION (Contd)

22. Using vernier caliper and micrometer, measure crankshaft dimensions shown in Figure 3. Compare measurements to specifications in Table 1. Wear greater than 0.002 in. (0.051 mm), or greater than 0.003 in. (0.076 mm) for item 8, requires regrinding.

Table 1. Crankshaft Dimensions and Points of Measurements.

1	51.813 in. (131.604 mm)
2	4.497–4.500 in. (11.426–11.43 cm)
3	2.438 in. (6.191 cm)
4	2.126–2.128 in. (5.40–5.405 cm)
5	2.00 in. (5.08 cm)
6	2.50 in. (6.35 cm)
7	2.00 in. (5.08 cm)
8	3.001–3.003 in. (7.622–7.628 cm)
9	5.998–6.000 in. (15.234–15.24 cm)
10	5.151–5.163 in. (13.083–13.114 cm)
11	0.173–0.196 in. (7.933–7.937 cm)
12	3.124–3.125 in. (4.389–4.973 cm)
13	3.761 in. (9.552 cm)
14	0.375 in. (0.953 mm)
15	3.625–3.626 in. (9.207–9.300 cm)

CRANKSHAFT CLEANING AND INSPECTION (Contd)

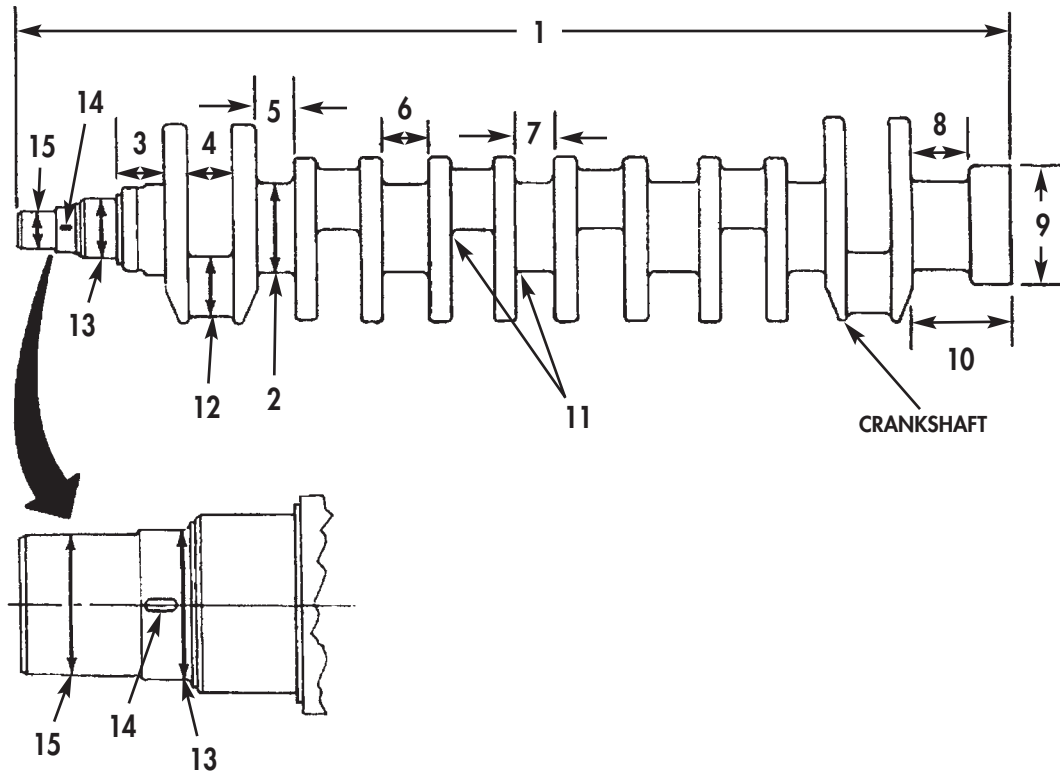


Figure 3. Crankshaft Measurements.

**DIRECT SUPPORT AND GENERAL SUPPORT
MAINTENANCE MANUAL
INCLUDING REPAIR PARTS AND SPECIAL TOOLS (RPSTL)**

FOR

M915, M915A1, M915A4, M916, M920 VEHICLES

NSN 2815-01-082-8125	P/N NTC400-3652-02	CUMMINS NTC-400 BIG CAM I DIESEL ENGINE W/CONTAINER
NSN 2815-01-142-2745	P/N 11669835	CUMMINS NTC-400 BIG CAM III DIESEL ENGINE W/CONTAINER

**FLEXPLATE, FLYWHEEL, FLYWHEEL HOUSING,
AND REAR COVER CLEANING AND INSPECTION**

INITIAL SETUP:

Tools and Special Tools

General mechanic's tool kit:

automotive (Item 1, WP 0061 00)

Maintenance and repair shop equipment:

automotive (Item 2, WP 0061 00)

Automotive maintenance and repair

supplemental set no. 2 (Item 3, WP 0061 00)

Magnetic crack detector (Item 5, WP 0061 00)

Equipment Condition

Flexplate, flywheel, flywheel housing, and rear
cover removed from engine (WP 0012 00).

FLEXPLATE, FLYWHEEL, FLYWHEEL HOUSING, AND REAR COVER CLEANING AND INSPECTION (Contd)

1. For general parts cleaning information, refer to CLEANING, WP 0051 00.
2. For general parts inspection information, refer to INSPECTION, WP 0051 00.

NOTE

Replace any part that does not pass visual inspection or that is outside specified wear limits.

Perform steps 3 and 4 for Big Cam I only.

3. Inspect flywheel (5) and spacer gear (4) for cracks, damaged teeth, and stripped or elongated bolt holes. Repair any stripped holes.
4. Using magnetic crack detector, inspect flywheel (5) for cracks. Follow manufacturer's instructions. Replace flywheel (5) or spacer gear (4) if damaged.

NOTE

Perform steps 5 and 6 for Big Cam III only.

5. Inspect flexplates (8), flywheel (7), retaining plate (9), and washer bearing (6) for cracks, damaged teeth, and stripped or elongated bolt holes. Repair any stripped holes.
6. Using magnetic crack detector, inspect flexplates (8) and flywheel (7) for cracks. Follow manufacturer's instructions. Replace flexplate (7) if damaged.
7. Inspect mounting surface of cylinder block (1) for cracks and stripped or elongated bolt holes. Repair any stripped holes.
8. Inspect rear cover (2) and flywheel housing (3) for cracks and stripped or elongated bolt holes. Repair any stripped holes.
9. Inspect dowel pins (10) for cracks and bends.
10. For flexplates (8), flywheel (5), flywheel housing (3), and rear cover (2) installation, refer to WP 0042 00.

FLEXPLATE, FLYWHEEL, FLYWHEEL HOUSING, AND REAR COVER CLEANING AND INSPECTION (Contd)

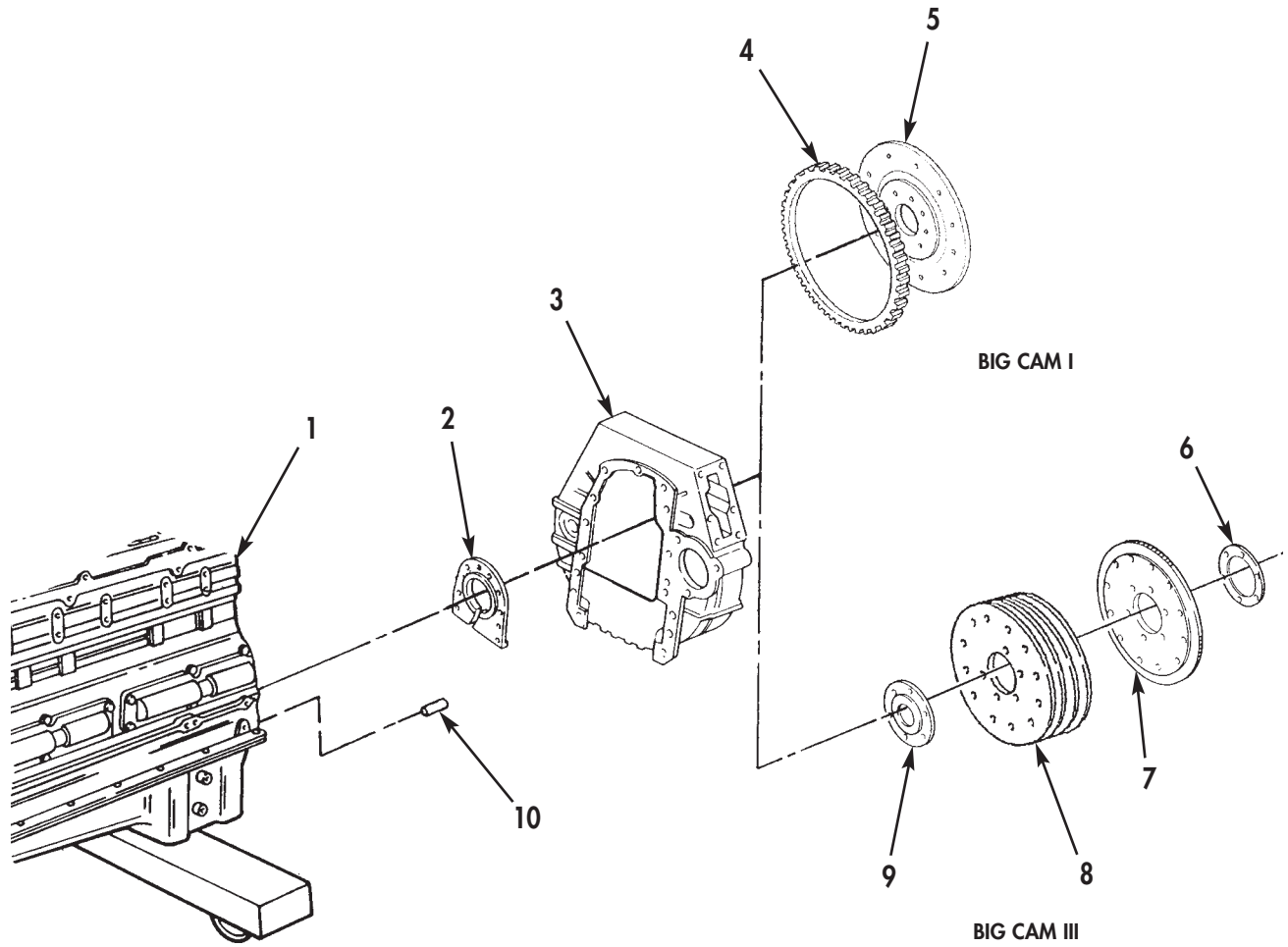


Figure 1. Flexplate, Flywheel, Flywheel Housing, and Rear Cover Cleaning and Inspection.

**DIRECT SUPPORT AND GENERAL SUPPORT
MAINTENANCE MANUAL
INCLUDING REPAIR PARTS AND SPECIAL TOOLS LIST (RPSTL)**

FOR

M915, M915A1, M915A4, M916, M920 VEHICLES

NSN 2815-01-082-8125	P/N NTC400-3652-02	CUMMINS NTC-400 BIG CAM I DIESEL ENGINE W/CONTAINER
NSN 2815-01-142-2745	P/N 11669835	CUMMINS NTC-400 BIG CAM III DIESEL ENGINE W/CONTAINER

**PISTONS, CONNECTING RODS, AND BEARINGS
DISASSEMBLY, CLEANING AND INSPECTION, ASSEMBLY**

INITIAL SETUP:

Tools and Special Tools

General mechanic's tool kit: automotive
(Item 1, WP 0061 00)
Maintenance and repair shop equipment:
automotive (Item 2, WP 0061 00)
Automotive maintenance and repair
supplemental set no. 2 (Item 3, WP 0061 00)
Connecting rod bushing driver
(Item 25, WP 0061 00)
Piston ring groove gauge
(Item 27, WP 0061 00)
Piston ring expander (Item 28, WP 0061 00)
Connecting rod checking fixture
(Item 26, WP 0061 00)
0.125 in. (3.175 mm) diameter rod
(Item 41, WP 0061 00)
Press
Oven

Materials/Parts (Contd)

Six intermediate compression rings
(Item 5, Table 3, WP 0062 00)
Six oil control rings
(Item 6, Table 3, WP 0062 00)

Equipment Condition

Piston, connecting rod, and bearing removed
from engine (WP 0012 00).

Materials/Parts

Crocus cloth (Item 4, WP 0060 00)
Rubber gloves (Item 32, WP 0060 00)
Lubricating oil (Item 19, WP 0060 00)
Six bushings (Item 1, Table 3, WP 0062 00)
Twelve connecting rod bearings
(Item 2, Table 3, WP 0062 00)
Six first compression rings
(Item 3, Table 3, WP 0062 00)
Six second compression rings
(Item 4, Table 3, WP 0062 00)

PISTONS, CONNECTING RODS, AND BEARINGS (Contd)

DISASSEMBLY

1. Remove first compression ring (2), second compression ring (1), intermediate compression ring (12), and oil control ring (11) from piston (10). Discard piston rings (2), (1), (12), and (11).

NOTE

Always discard connecting rod bearings as a set.

2. Remove connecting rod bearings (8) from connecting rod (5) and connecting rod cap (7) if not previously removed. Discard connecting rod bearings (8).
3. Remove two dowel pins (6) from connecting rod cap (7).
4. Remove two retaining rings (4) from piston (10).

WARNING

Wear rubber gloves when removing piston pin to prevent burns from boiling hot water or hot piston. Failure to comply may result in injury to personnel.

CAUTION

Do not use hammer or any other tool to remove piston pin. Remove piston pin by hand only. Failure to comply may result in damage to piston.

5. Heat piston (10), piston pin (3), and connecting rod (5) to 210° F (98.9° C) for 10 minutes in boiling water or oven.
6. Remove piston pin (3) from piston (10) and connecting rod (5).
7. Remove piston (10) from connecting rod (5).
8. Using press and connecting rod bushing driver, remove bushing (9) from connecting rod (5). Discard bushing (9).
9. Repeat steps 1 through 8 for all remaining piston (10), connecting rod (5), and bearing (8) assemblies.

PISTONS, CONNECTING RODS, AND BEARINGS (Contd)

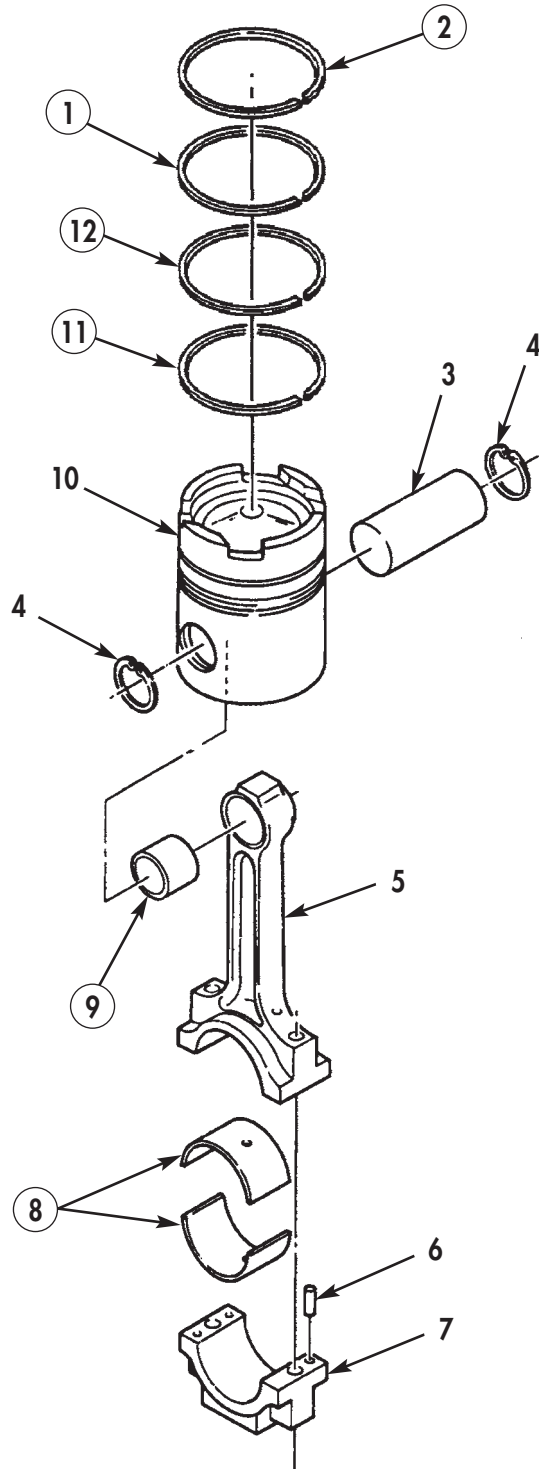


Figure 1. Piston, Connecting Rod, and Bearing Disassembly.

PISTONS, CONNECTING RODS, AND BEARINGS (Contd)

CLEANING AND INSPECTION

1. For general parts cleaning information, refer to CLEANING, WP 0051 00.
2. For general parts inspection information, refer to INSPECTION, WP 0051 00.

NOTE

Replace any part that does not pass visual inspection or is outside specified wear limits.

3. Inspect piston (1) for cracks, breaks, scores, galling, or scratches. Remove small scratches with crocus cloth.
4. Inspect piston ring grooves (2) for cracks, breaks, missing sections, and galling.

NOTE

There are two different ways to inspect piston ring groove clearance. Either method is acceptable. If using piston ring groove gauge, perform step 5. If piston ring groove gauge is not available, perform step 6.

5. Using piston ring groove gauge, measure piston ring groove (2). Discard piston (1) if piston ring groove gauge widest shoulder comes in contact with piston (1).
6. Position a new piston ring (3) in piston ring groove (2). Using a feeler gauge, check the clearance between piston ring (3) and piston ring groove (2). Replace piston (1) if clearance is more than 0.006 in. (0.15 mm).

NOTE

Ensure temperature is 70°–90° F (21°–32° C), or false readings may be taken.

7. Using micrometer or equivalent, measure piston outside diameter at point A, 1.0 in. (25.4 mm) below piston ring groove (2). Piston outside diameter at point A should be 5.477–5.480 in. (13.912–13.919 cm). Replace piston (1) if worn beyond specifications.
8. Using micrometer or equivalent, measure piston skirt outside diameter at point B, 1.0 in. (25.4 mm) above bottom of piston (1). Piston outside diameter at point B should be 5.489–5.493 in. (13.942–13.952 cm). Replace piston (1) if worn beyond specifications.

NOTE

Ensure temperature is 70°–90° F (21°–32° C). At 70° F (21° C), add 0.0005 in. (0.013 mm) for every 10° F (12° C) up to 90° F (32° C), or false readings may result.

9. Using inside micrometer, measure piston pin bore at point C. Piston pin bore should be 1.9985–1.9990 in. (5.076–5.078 cm). Replace piston (1) if piston pin bore is above 2.0000 in. (5.080 cm).
10. Using micrometer or equivalent, measure piston pin (5) outside diameter. Piston pin (5) should be 1.9988–1.9990 in. (5.0769–5.0775 cm). Replace piston pin (5) if outside diameter is out of round more than 0.001 in. (0.025 mm).
11. Inspect dowel pins (4) for cracks, chips, and bends.
12. Using micrometer, measure outside diameter of two dowel pins (4). Dowel pins (4) should be 0.220–0.250 in. (5.59–6.35 mm). Replace dowel pins (4) if not within specifications.

PISTONS, CONNECTING RODS, AND BEARINGS (Contd)

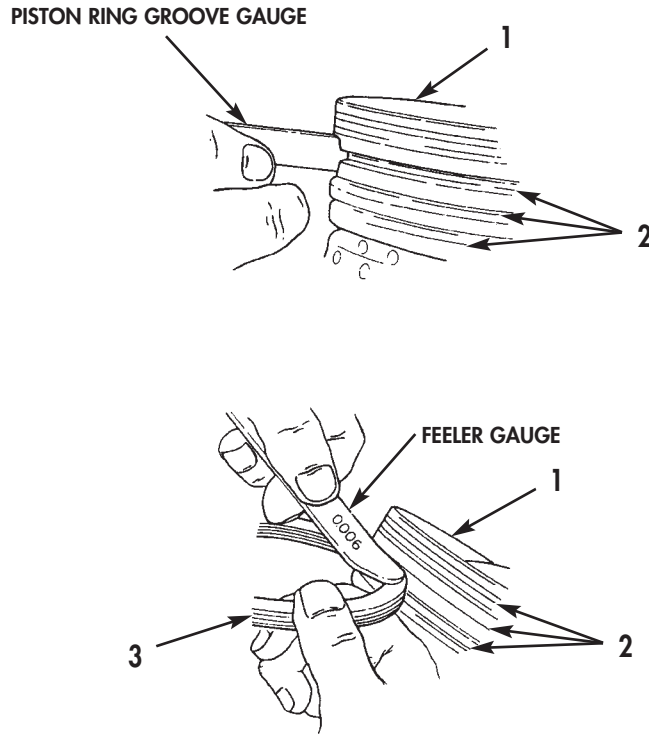


Figure 2. Piston Ring Groove Measurement.

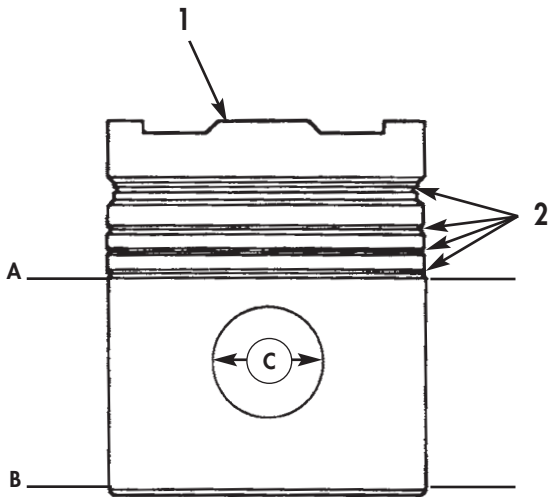


Figure 3. Piston Measurement.

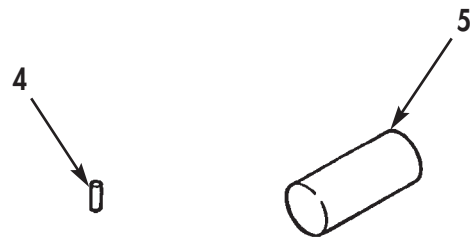


Figure 4. Dowel Pin and Piston Pin.

PISTONS, CONNECTING RODS, AND BEARINGS (Contd)

CLEANING AND INSPECTION (Contd)

13. Inspect twelve connecting rod bolts (1) for bends, cracks, chipped or stripped teeth. Replace connecting rod bolts (1) if damaged.
14. Using a micrometer, inspect connecting rod bolt (1) pilot area outside diameter. Outside diameter of pilot area should be 0.541–0.545 in. (13.74–13.84 mm). Replace any connecting rod bolt (1) if outside diameter of pilot area exceeds 0.540 in. (13.72 mm).
15. Using a micrometer, inspect connecting rod bolt (1) threaded area outside diameter. Outside diameter of threaded area should be 0.6245–0.6250 in. (15.862–15.875 mm). Replace connecting rod bolt (1) if outside diameter of threaded area exceeds 0.6242 in. (15.855 mm).

NOTE

Always replace connecting rod and connecting rod cap as a matched set.

16. Inspect connecting rod (2) and connecting rod cap (3) for nicks, dents, scratches, and gouges. Replace connecting rod (2) and connecting rod cap (3) if any nicks, dents, scratches, or gouges are deeper than 0.03125 in. (0.7938 mm).

NOTE

Perform steps 17 and 18 for connecting rod assembly inside diameter measurement. Do not take measurement where connecting rod and connecting rod cap meet, or an incorrect measurement may result.

17. Install connecting rod cap (3) on connecting rod (2) with two connecting rod bolts (4). Tighten bolts (4) 140–150 lb-ft (190–203 N•m).
18. Using inside micrometer, measure inside diameter of connecting rod (2) at connecting rod cap (3) assembly at point A. Connecting rod inside diameter should be 3.3157–3.3167 in. (8.4219–8.4244 cm). Replace connecting rod (2) and connecting rod cap (3) if not within specifications.

NOTE

Perform steps 19 through 22 for connecting rod calibration.

19. Install connecting rod (2) on connecting rod checking fixture.
20. Using connecting rod checking fixture, check connecting rod (2) length. Replace connecting rod (2) if longer than calibration rod on connecting rod checking fixture, or if more than 0.002 in. (0.050 mm) shorter.
21. Using connecting rod checking fixture, check alignment of connecting rod bores (5). Take first measurement of connecting rod bores (5). Remove connecting rod (2) from connecting rod checking fixture. Rotate connecting rod (2) 180°, install on connecting rod checking fixture, and take second measurement. Replace connecting rod (2) if there is more than 0.010 in. (0.254 mm) difference in measurements.
22. Using feeler gauge, measure connecting rod (2) for twist between piston pin holding mandrel (6) and dial indicator holding plate. Replace connecting rod (2) if clearance between piston pin holding mandrel (6) and dial indicator holding plate is more than 0.020 in. (0.5078 mm).

PISTONS, CONNECTING RODS, AND BEARINGS (Contd)

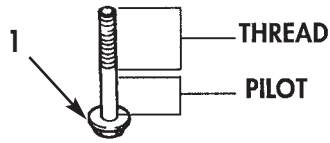


Figure 5. Connecting Rod Bolt Inspection.

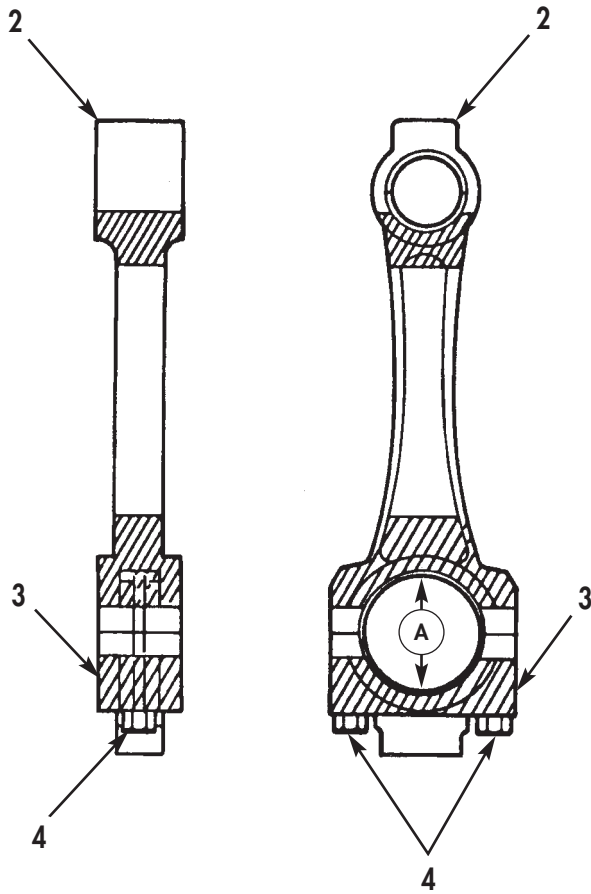


Figure 6. Connecting Rod Inspection.

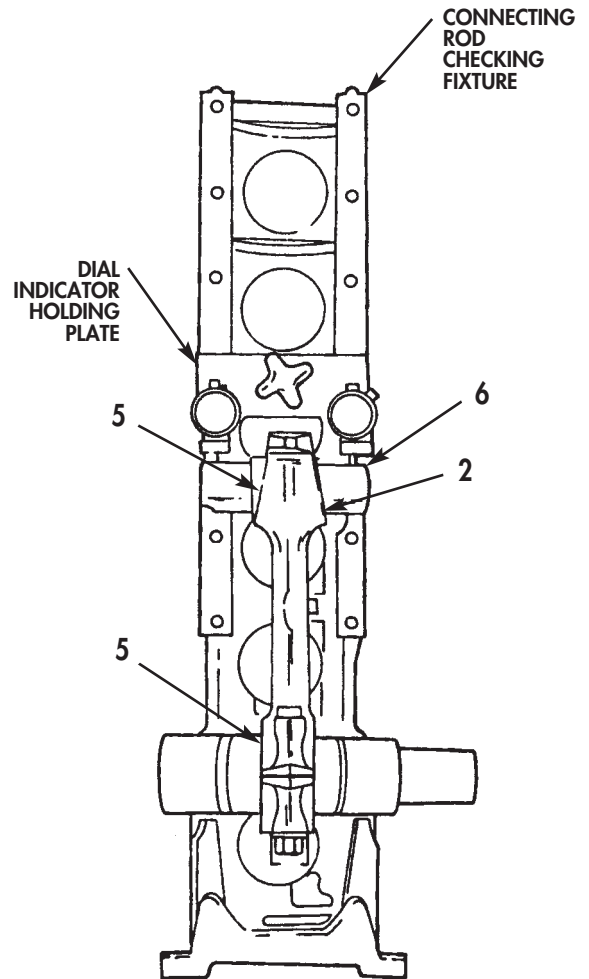


Figure 7. Connecting Rod Alignment.

PISTONS, CONNECTING RODS, AND BEARINGS (Contd)

ASSEMBLY

NOTE

Apply lubricating oil to all parts before assembly.

1. Align oil holes in new bushing (10) with oil holes in connecting rod (6). Using press and connecting rod bushing driver, install new bushing (10) in connecting rod (6). Ensure that 0.125 in. (3.175 mm) diameter rod can pass easily through oil holes.
2. Install one retaining ring (4) in piston (5).

WARNING

Wear rubber gloves when installing piston pin to prevent burns from boiling hot water or hot piston. Failure to comply may result in injury to personnel.

3. Heat piston (5) to 210° F (98.9° C) for 15 minutes in water or oven.

CAUTION

Do not use hammer or any other tool to install piston pin. Install piston pin by hand only. Failure to comply may result in damage to piston.

4. Position connecting rod (6) in piston (5) and install connecting rod (6) to piston (5) with piston pin (3).
5. Install retaining ring (4) in piston (5).

NOTE

If one or more four-ring-groove pistons are to be replaced, replace all pistons. New replacement piston will have three piston ring grooves instead of four. Never mismatch pistons.

If you are installing three-ring-groove piston, perform step 6.
If you are installing four-ring-groove piston, perform step 7.

6. Using piston ring expander, install three new piston rings (13), (14), and (15) on piston (5) with word "top" facing up. Start with new oil control ring (13) on bottom, new second compression ring (14) in middle, and new first compression ring (15) on top.
7. Using piston ring expander, install four new piston rings (11), (12), (1), and (2) on piston (5) with word "top" facing up. Start with new oil control ring (11) on bottom, new intermediate compression ring (12) second from bottom, new second compression ring (1) in middle, and a new first compression ring (2) on top.
8. Install two dowel pins (7) in connecting rod cap (8).

NOTE

Always replace connecting rod bearings as a set.

9. Install new connecting rod bearings (9) in connecting rod (6) and connecting rod cap (8).
10. Repeat steps 1 through 9 for all remaining piston (5), connecting rod (8), and bearing (7) assemblies.
11. For piston, connecting rod, and bearing installation, refer to WP 0042 00.

PISTONS, CONNECTING RODS, AND BEARINGS (Contd)

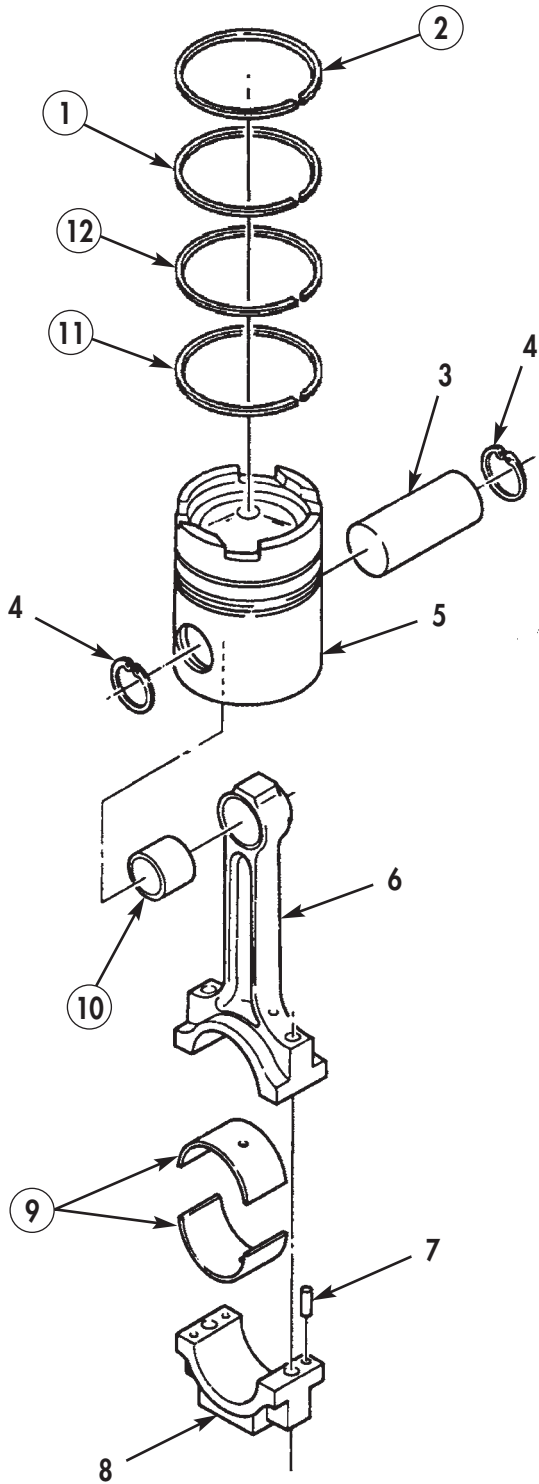


Figure 8.
Piston, Connecting Rod, and Rod Bearing Assembly.

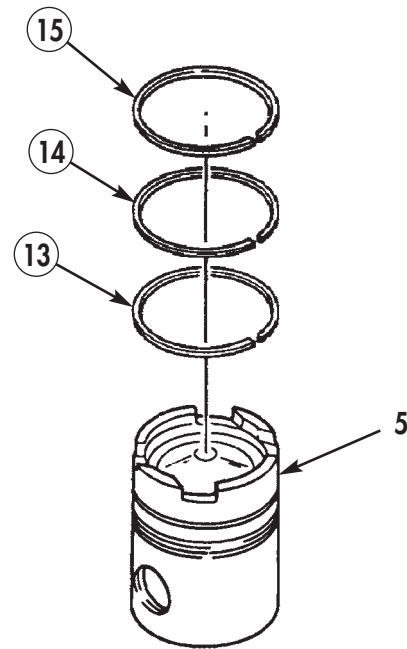


Figure 9.
Replacement Piston Ring Assembly.

END OF WORK PACKAGE

**DIRECT SUPPORT AND GENERAL SUPPORT
MAINTENANCE MANUAL
INCLUDING REPAIR PARTS AND SPECIAL TOOLS LIST (RPSTL)**

FOR

M915, M915A1, M915A4, M916, M920 VEHICLES

NSN 2815-01-082-8125	P/N NTC400-3652-02	CUMMINS NTC-400 BIG CAM I DIESEL ENGINE W/CONTAINER
NSN 2815-01-142-2745	P/N 11669835	CUMMINS NTC-400 BIG CAM III DIESEL ENGINE W/CONTAINER

**CAMSHAFT, CAMSHAFT FOLLOWERS, AND PUSH RODS
DISASSEMBLY, CLEANING AND INSPECTION, ASSEMBLY**

INITIAL SETUP:

Tools and Special Tools

General mechanic's tool kit: automotive
(Item 1, WP 0061 00)
Maintenance and repair shop equipment:
automotive (Item 2, WP 0061 00)
Automotive maintenance and repair
supplemental set no. 2 (Item 3, WP 0061 00)

Equipment Condition

Camshaft, camshaft followers, and push rods
removed from cylinder block (WP 0012 00).

Materials/Parts

240-grit aluminum oxide paper
(Item 22, WP 0060 00)
Prussian blue (Item 9, WP 0060 00)
Thrust bearing (Item 1, Table 4, WP 0062 00)
Two expansion plugs
(Item 2, Table 4, WP 0062 00)

CAMSHAFT, CAMSHAFT FOLLOWERS, AND PUSH RODS (Contd)

DISASSEMBLY

1. Using press, remove camshaft gear (2) and thrust bearing (3) from camshaft (5). Discard thrust bearing (3).
2. Remove keyway (4) and orifice plug (1) from camshaft (5).
3. Remove two screws (6) retaining camshaft follower shaft (11) in camshaft follower housing (12).
4. Remove two expansion plugs (10) from ends of camshaft follower housing (12). Discard expansion plugs (10).

NOTE

Tag camshaft followers in order as they are removed to aid in assembly.

5. Using press and mandral, remove two camshaft follower shafts (11), intake camshaft followers (7), injector camshaft followers (8), and exhaust camshaft followers (9) from camshaft follower housing (12).
6. Repeat steps 3 through 5 for remaining two camshaft follower housings (12).

NOTE

Intake camshaft follower is shown. All camshaft followers are alike and disassembled in the same manner.

7. Using hammer and drift punch, remove roll pin (13) securing roller pin (14) and roller (15) in intake camshaft follower (7).
8. Remove roller pin (14) and roller (15) from intake camshaft follower lever (7).
9. Repeat steps 7 and 8 for remaining five intake camshaft followers (7), six injector camshaft followers (8), and six exhaust camshaft followers (9).

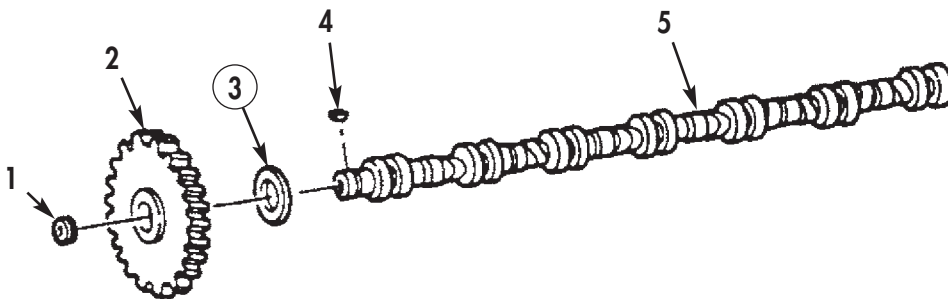


Figure 1. Camshaft Disassembly.

CAMSHAFT, CAMSHAFT FOLLOWERS, AND PUSH RODS (Contd)

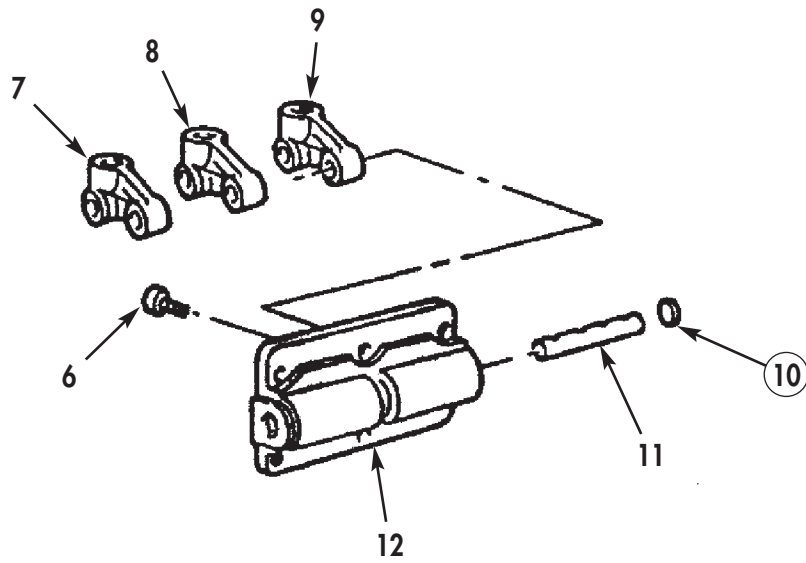


Figure 2. Camshaft Follower Housing Disassembly.

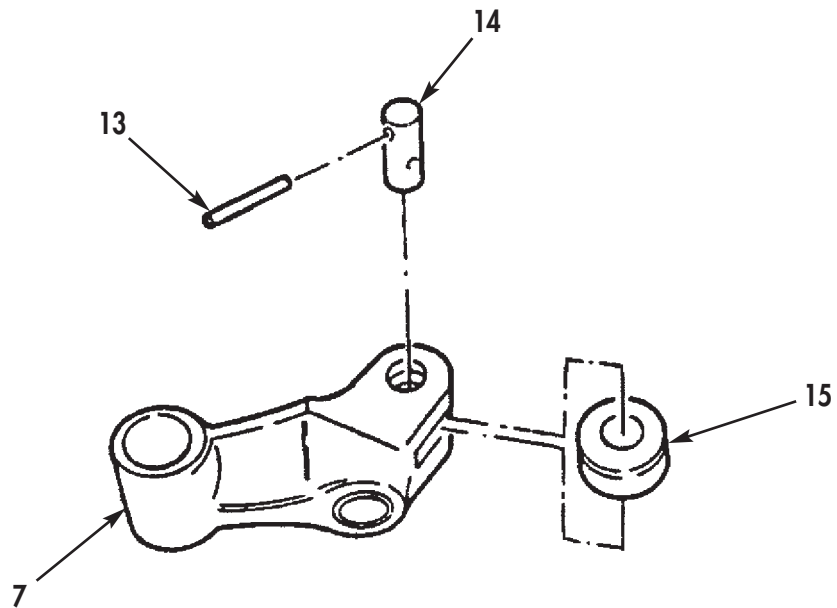


Figure 3. Camshaft Follower Disassembly.

CAMSHAFT, CAMSHAFT FOLLOWERS, AND PUSH RODS (Contd)

CLEANING AND INSPECTION

1. For general parts cleaning information, refer to CLEANING, WP 0051 00.
2. For general parts inspection information, refer to INSPECTION, WP 0051 00.

NOTE

Replace any part that does not pass visual inspection or is outside specified wear limits.

3. Inspect camshaft gear (1) for cracks, chips, rounded or stripped teeth.
4. Using micrometer or equivalent, measure camshaft bearing journals (6) outside diameter. Camshaft bearing journals (6) outside diameter should be 2.496–2.497 in. (6.339–6.342 cm). Discard camshaft (2) if camshaft bearing journals (6) outside diameter is 2.495 in. (6.337 cm) or smaller.
5. Inspect camshaft follower housing (10) for cracks, chips, and breaks.
6. Inspect camshaft follower housing (10) for sharp edges, nicks, or burrs. Camshaft follower housing (10) should have a slight radius. Remove sharp edges, nicks, or burrs with 240-grit aluminum oxide paper attached to a split rod and drill.
7. Inspect cam follower bushing (11) on intake (7), injector (8), and exhaust cam followers (9) for scratches, pitting, scoring and other damage. Discard intake (7), injector (8), and exhaust cam followers (9) if cam follower bushing (11) is damaged.

NOTE

Cam follower bushing inside diameter must measure 0.7501–0.7511 in. (19.053–19.078 mm).

8. Using micrometer, measure inside diameter of cam follower bushing (11). Discard intake (7), injector (8), or exhaust cam followers (9) if cam follower bushing (11) diameter measures more than 0.752 in. (19.101 mm).
9. Inspect intake (7), injector (8), and exhaust cam follower levers (9) for cracks using magnetic particle inspection (WP 0051 00). Discard intake (7), injector (8), or exhaust cam follower levers (9) if any cracks are found.
10. Inspect pushrod insert (13) for scoring, galling, pitting, and excessive wear.
11. Inspect intake (3), injector (4), and exhaust pushrod (5) for bends or out-of-round. Discard intake (3), injector (4), or exhaust pushrod (5) if bent or out-of-round is more than 0.035 in. (0.889 mm).
12. Check pushrod insert (13) using ball end of intake (3), injector (4), and exhaust pushrods (5) as follows:
 - a. Apply a coat of Prussian blue compound to ball end of intake (3), injector (4), and exhaust pushrods (5).
 - b. Install ball end of intake (3), injector (4), and exhaust pushrods (5) into pushrod insert (13) and rotate 80°.
 - c. Replace intake (7), injector (8), and exhaust cam followers (9) if pushrod insert (13) is damaged or has less than 80% contact with ball end of intake (3), injector (4), and exhaust pushrods (5).
13. Inspect roller (12) for cracks, breaks, and other damage. Discard intake (7), injector (8), or exhaust cam followers (9) if roller (12) is damaged.

NOTE

Intake and exhaust cam follower roller inside diameter must measure 0.5005–0.5015 in. (12.713–12.738 mm). Discard intake or exhaust cam followers if roller (12) is out-of-round. Discard intake injector, or exhaust cam followers if inside diameter measures more than 0.503 in. (12.776 mm).

Injector cam follower roller inside diameter must measure 0.703–0.704 in. (17.856–17.882 mm). Discard injector cam follower if inside diameter measures more than 0.705 in. (17.907 mm).

14. Using small bore gauge, measure roller (12) inside diameter.

CAMSHAFT, CAMSHAFT FOLLOWERS, AND PUSH RODS (Contd)

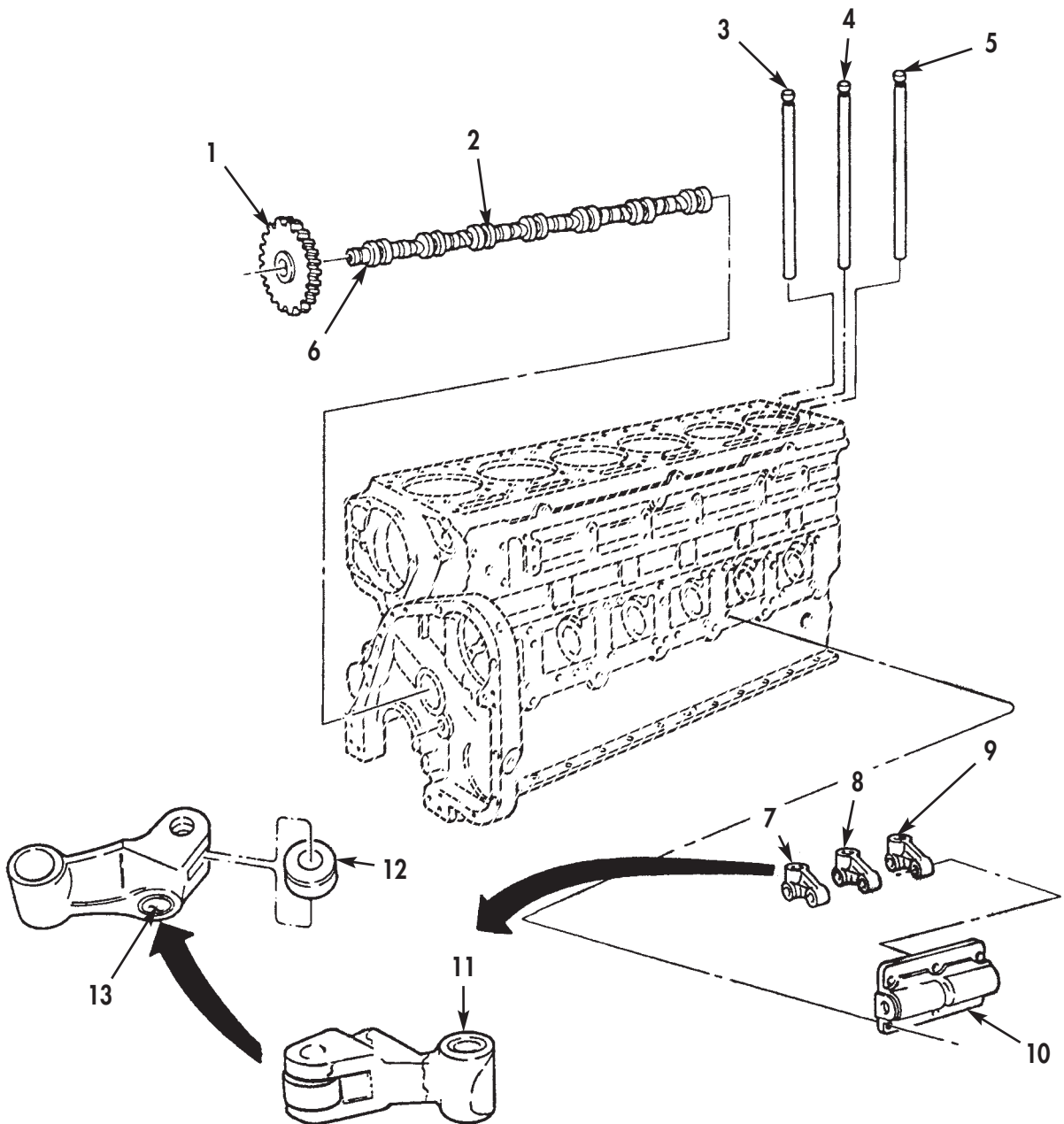


Figure 4. Camshaft, Camshaft Followers, and Push Rods Cleaning and Inspection.

CAMSHAFT, CAMSHAFT FOLLOWERS, AND PUSH RODS (Contd)

CLEANING AND INSPECTION (Contd)

15. Inspect roller (4) to ensure it is not out-of-round. Discard intake (1), injector (2), or exhaust cam follower (3) if roller (4) is out-of-round.

NOTE

Outside diameter of roller must measure 1.2495–1.2505 in.
(31.737–31.763 mm).

16. Using micrometer, measure roller (4) outside diameter. Discard intake (1), exhaust (3) or injector cam followers (2) if outside diameter measures less than 1.2485 in. (31.712 mm).
17. Check concentricity of inside diameter with outside diameter of intake (1), injector (2), and exhaust cam followers (3). Discard intake (1), injector (2), or exhaust cam followers (3) if concentricity of inside diameter with outside diameter is not within 0.0020 in. (0.051 mm).
18. Check intake (1), injector (2), and exhaust cam follower (3) squareness of sides with roller pin bore. Discard intake (1), injector (2), and exhaust cam followers (3) if sides are not parallel to each other or not square to bore within 0.0040 in. (0.102 mm).
19. Inspect roller pin (6) for cracks, breaks, and other damage. Discard intake (1), injector (2), and exhaust cam followers (3) if roller pin (6) is damaged.

NOTE

Intake or exhaust roller pin outside diameter must measure
0.4997–0.500 in. (12.692–12.700 mm). Injector roller pin
outside diameter must measure 0.6997–0.7000 in.
(17.772–17.780 mm).

20. Using micrometer, measure outside diameter of roller pin (6).
 - a. Discard intake (1) or exhaust cam followers (3) if outside diameter measures less than 0.497 in. (12.624 mm).
 - b. Discard injector cam follower (2) if outside diameter measures less than 0.697 in. (17.704 mm).
21. Using micrometer, measure roller pin bore (5).
 - a. Discard intake (1) or exhaust cam followers (3) if roller pin bore (5) is not within 0.4990–0.4995 in. (12.675–12.687 mm).
 - b. Discard injector cam follower (2) if roller pin bore (5) is not within 0.6992–0.6997 in. (17.760–17.772 mm).

CAMSHAFT, CAMSHAFT FOLLOWERS, AND PUSH RODS (Contd)

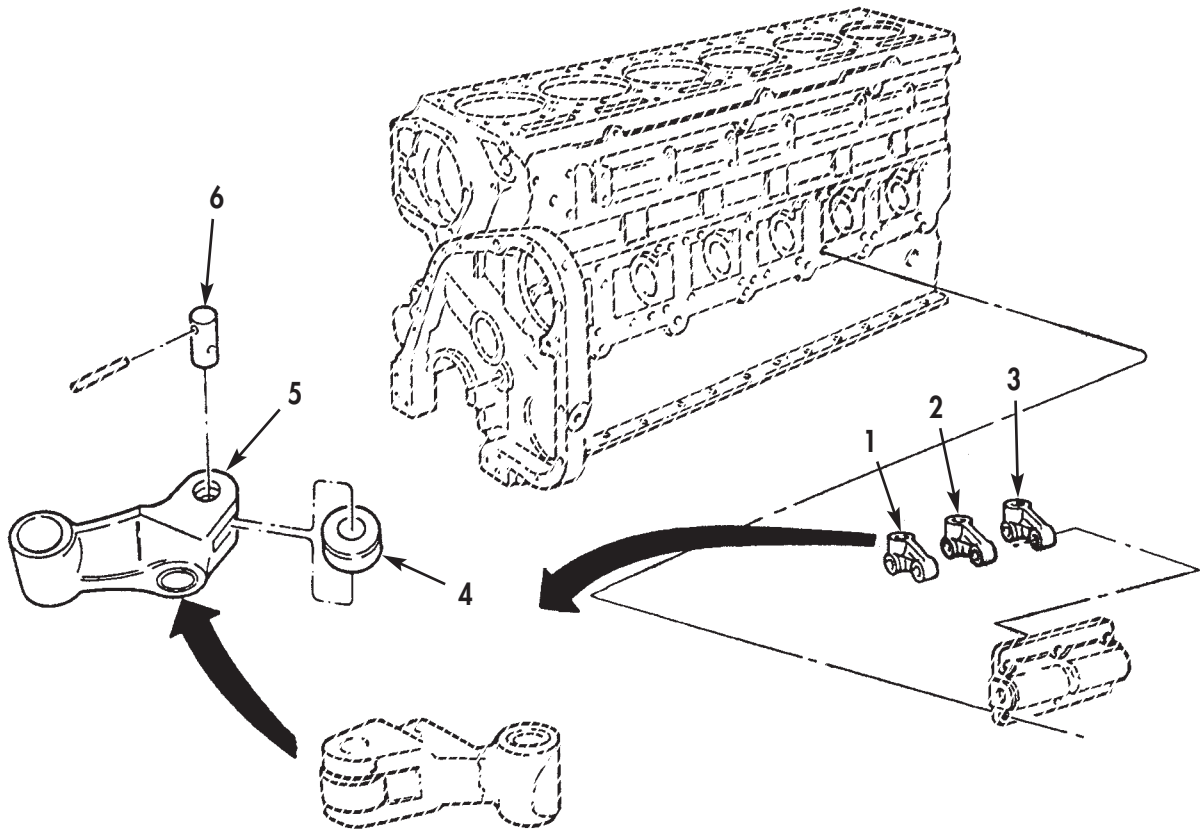


Figure 5. Intake, Injector, and Exhaust Cam Followers Cleaning and Inspection.

CAMSHAFT, CAMSHAFT FOLLOWERS, AND PUSH RODS (Contd)

ASSEMBLY

1. Install roller pin (2) and roller (3) on intake cam follower (4).
2. Using 0.006 in. (0.15 mm) feeler gauge between intake cam follower (4) and roller (3), install roller pin (2) on intake cam follower (4) and roller (3). Secure roller pin (2) to intake cam follower (4) with roll pin (1).

NOTE

All camshaft follower housings are assembled in the same manner. Repeat step 3 for remaining cam follower housings.

Ensure injector cam follower is in center position and that cam follower pushrod sockets are on the same side as dowel holes in housing.

3. Install two exhaust camshaft followers (6), injector camshaft followers (5), intake camshaft followers (4), and camshaft follower shafts (8) on camshaft follower housing (9).

NOTE

Expansion plugs should be at least flush with edge of hole or not more than 0.010 in. (0.254 mm) below edge of hole.

Apply light coat of cup plug sealant to expansion plug hole in each end.

4. Using press and mandrel, install two new expansion plugs (7) on ends of camshaft follower housing (9).
5. Install two screws (10) securing camshaft follower shaft (8) on camshaft follower housing (9).
6. Install orifice plug (11) and keyway (14) on camshaft (15). Tighten orifice plug (11) 5–10 lb-ft (7–13 N•m).

WARNING

Use insulated gloves when handling heated camshaft drive gear. Failure to observe this warning may result in injury to personnel.

CAUTION

Do not use cutting torch to heat camshaft gear; damage will result.

7. Heat camshaft gear (12) evenly in oven to 400° F (209° C).
8. Using press, install hot camshaft gear (12), new thrust bearing (13), and keyway (14) on camshaft (15).

CAMSHAFT, CAMSHAFT FOLLOWERS, AND PUSH RODS (Contd)

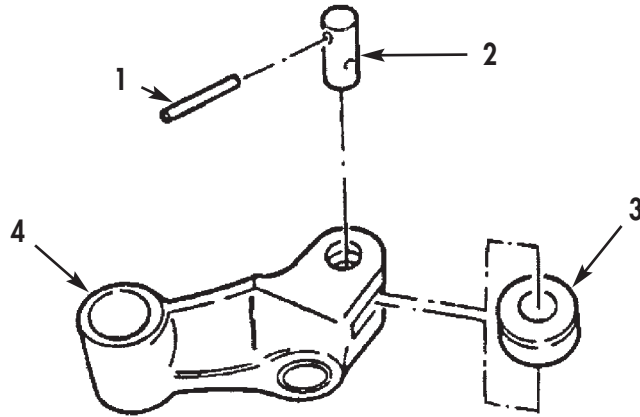


Figure 6. Camshaft Follower Assembly.

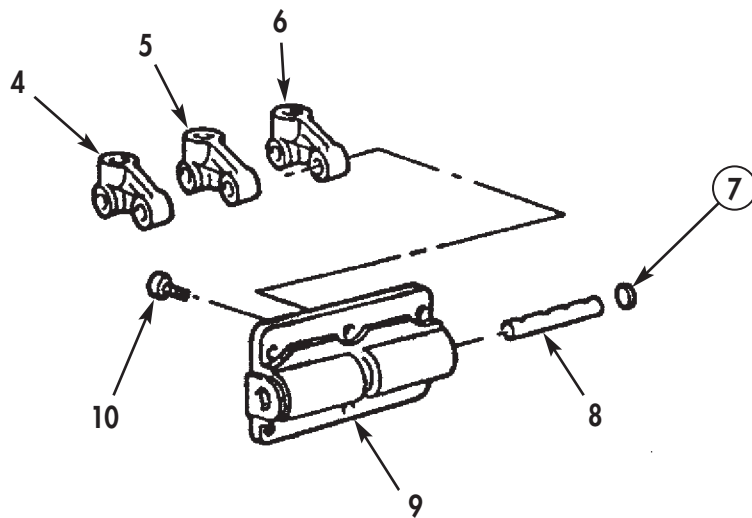


Figure 7. Camshaft Follower Assembly.

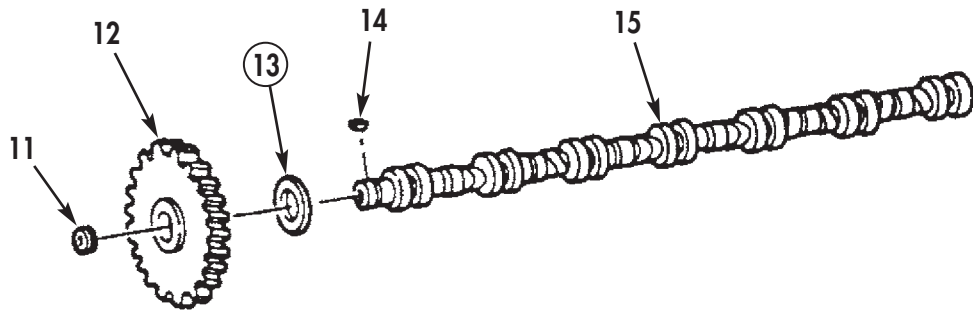


Figure 8. Camshaft Assembly.

END OF WORK PACKAGE

**DIRECT SUPPORT AND GENERAL SUPPORT
MAINTENANCE MANUAL
INCLUDING REPAIR PARTS AND SPECIAL TOOLS LIST (RPSTL)**

FOR

M915, M915A1, M915A4, M916, M920 VEHICLES

NSN 2815-01-082-8125	P/N NTC400-3652-02	CUMMINS NTC-400 BIG CAM I DIESEL ENGINE W/CONTAINER
NSN 2815-01-142-2745	P/N 11669835	CUMMINS NTC-400 BIG CAM III DIESEL ENGINE W/CONTAINER

**ROCKER LEVERS AND ROCKER LEVER HOUSING
DISASSEMBLY, CLEANING AND INSPECTION, ASSEMBLY**

INITIAL SETUP:

Tools and Special Tools

General mechanic's tool kit:
 automotive (Item 1, WP 0061 00)
 Maintenance and repair shop equipment:
 automotive (Item 2, WP 0061 00)
 Automotive maintenance and repair
 supplemental set no. 2 (Item 3, WP 0061 00)
 Rocker lever block and mandrel set
 (Item 30, WP 0061 00)
 0.250 in. (6.350 mm) radius gauge
 (Item 31, WP 0061 00)
 Split rod (Item 32, WP 0061 00)
 Mandrel (Item 39, WP 0061 00)
 Press

Equipment Condition

Rocker levers and rocker lever housing
 removed from engine (WP 0012 00).

Materials/Parts

Lubricating oil (Item 19, WP 0060 00)
 240-grit aluminum oxide paper
 (Item 22, WP 0060 00)
 Six O-rings (Item 1, Table 5, WP 0062 00)
 Eighteen bushings
 (Item 2, Table 5, WP 0062 00)
 Six ball socket seats
 (Item 3, Table 5, WP 0062 00)

ROCKER LEVERS AND ROCKER LEVER HOUSING (Contd)

DISASSEMBLY

1. Remove two exhaust rocker lever adjusting screws (3) and nuts (4) from exhaust rocker levers (2).
2. Remove two injector rocker lever adjusting screws (8) and nuts (9) from injector rocker levers (7).
3. Remove two intake rocker lever adjusting screws (12) and nuts (13) from intake rocker levers (11).
4. Remove setscrew (14) from rocker lever shaft (16) and rocker arm housing (15).

NOTE

Tag all rocker levers before disassembly to aid in assembly.

5. Using press and mandrel, remove rocker lever shaft (16), two exhaust rocker levers (2), injector rocker levers (7), and intake rocker levers (11) from rocker lever housing (15).
6. Remove two plugs (18) and O-rings (17) from each end of rocker lever shaft (16). Discard O-rings (17) and expansion plugs (18).
7. Using press and rocker lever block and mandrel set, remove two bushings (1) from exhaust rocker levers (2). Discard bushings (1).
8. Using press and rocker lever block and mandrel set, remove two bushings (5) from injector rocker levers (7). Discard bushings (5).
9. Remove two ball socket seats (6) from injector rocker levers (7). Discard ball socket seats (6).
10. Using press and rocker lever block and mandrel set, remove two bushings (10) from intake rocker levers (11). Discard bushings (10).
11. Repeat steps 1 through 10 for remaining two rocker lever housings.

CLEANING AND INSPECTION

1. For general parts cleaning information, refer to CLEANING, WP 0051 00.
2. For general parts inspection information, refer to INSPECTION, WP 0051 00.

NOTE

Replace any part that does not pass visual inspection or is outside specified wear limits.

3. Inspect rocker lever housing (15) for cracks, breaks, chips, elongated or stripped bolt holes. Repair any damaged bolt holes.
4. Inspect rocker lever housing (15) breather vent hole and oil passages for blockage and obstructions. Clean out breather vent hole and oil passages if obstructed.
5. Inspect rocker lever housing (15) shaft bore, for sharp edges, nicks, or burrs. Rocker lever housing (15) shaft bore should have slight radius. Remove sharp edges, nicks, or burrs with 240-grit aluminum oxide paper attached to a split rod and drill.
6. Using inside micrometer, measure rocker lever housing (15) shaft bore inside diameter. Rocker lever housing (15) shaft bore inside diameter should be 1.1238–1.1246 in. (2.855–2.857 cm). Replace rocker lever housing (15) if rocker lever housing (15) shaft bore inside diameter is not within specifications.
7. Inspect rocker lever shaft (16) for scoring or ridges created from rocker lever movement.
8. Using micrometer, measure rocker lever shaft (16) outside diameter. rocker lever shaft (16) outside diameter should be 1.1230–1.1240 in. (2.552–2.855 cm). Replace rocker lever shaft (16) if outside diameter exceeds 1.1220 in. (2.850 cm).

ROCKER LEVERS AND ROCKER LEVER HOUSING (Contd)

CLEANING AND INSPECTION (Contd)

9. Inspect adjusting screws (3), (8), and (12) for stripped threads.
10. Using a 0.250 in. (6.350 mm) radius gauge, measure adjusting screws (3), (8), and (12) ball end. Replace adjusting screws (3), (8), and (12) if ball end is flat or out-of-round.
11. Inspect adjusting nuts (4), (9), and (13) for stripped threads.
12. Inspect rocker levers (2), (7), and (11) for cracks, bends, or stripped threads.

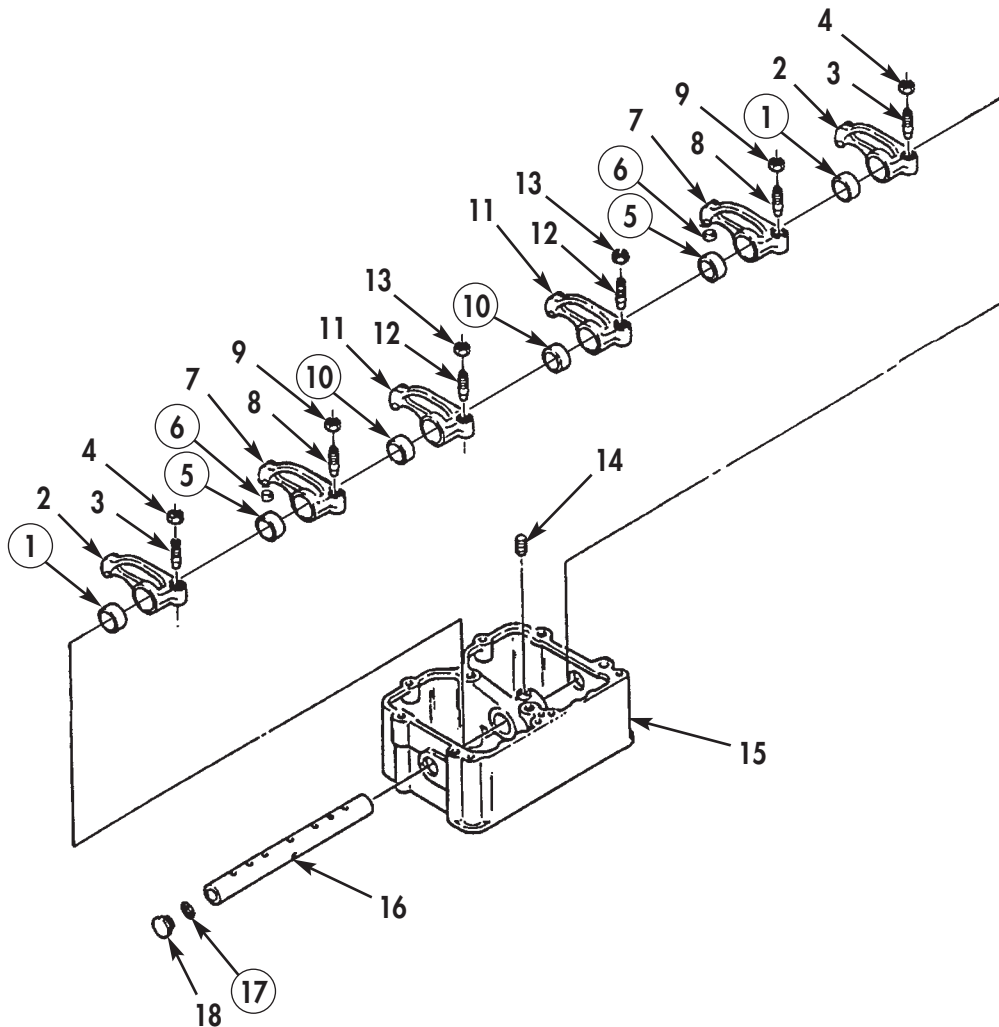


Figure 1. Rocker Levers and Rocker Lever Housing Disassembly.

ROCKER LEVERS AND ROCKER LEVER HOUSING (Contd)

ASSEMBLY

NOTE

Apply lubricating oil to all parts before assembly.

On intake rocker levers with oil drilling to crosshead nose end, install new bushing so nose hole is closed and slot hole is in line with adjusting screw hole.

1. Using press and rocker lever block and mandrel set, install two new bushings (10) in intake rocker levers (11).

NOTE

On injector and exhaust rocker levers, install new bushing so oil holes to crosshead nose or injector link and adjusting screw are open to allow for oil flow.

2. Using press and rocker lever block and mandrel set, install two new bushings (1) in exhaust rocker levers (2).
3. Using press and rocker lever block and mandrel set, install two new bushings (5) in injector rocker levers (7).
4. Install two new ball socket seats (6) on injector rocker levers (7).
5. Using press, install two new plugs (18) in ends of rocker lever shaft (16).

NOTE

Remove tags from rocker levers before assembly.

6. Position two exhaust rocker levers (2), injector rocker levers (7), and intake rocker levers (11) in their tagged positions in rocker lever housing (15).

NOTE

Ensure rocker lever shaft is positioned with oil supply screw hole facing up and seven oil holes facing flat side of rocker lever housing.

7. Install rocker lever shaft (16) through rocker lever housing (15) and two exhaust rocker levers (2), injector rocker levers (7), and intake rocker levers (11). Leave 0.500 in. (12.70 mm) of rocker lever shaft (16) extending out of rocker lever housing (15).
8. Install new O-ring (17) on rocker lever shaft (16) and push rocker lever shaft (16) back through rocker lever housing (15). Leave 0.500 in. (12.70 mm) of rocker lever shaft (16) extending out of rocker lever housing (15) opposite side.
9. Install new O-ring (17) on rocker lever shaft (16) and push rocker lever shaft (16) through rocker lever housing (15) until rocker lever shaft (16) is even with rocker lever housing (15).
10. Install setscrew (14) in rocker lever shaft (16) and rocker arm housing (15).
11. Install two exhaust rocker lever adjusting screws (3) and nuts (4) in exhaust rocker levers (2).
12. Install two injector rocker lever adjusting screws (8) and nuts (9) in injector rocker levers (7).
13. Install two intake rocker lever adjusting screws (12) and nuts (13) in intake rocker levers (11).
14. Repeat steps 1 through 14 for remaining two rocker lever and rocker lever housings.
15. For rocker levers and rocker housing installation, refer to WP 0043 00.

ROCKER LEVERS AND ROCKER LEVER HOUSING (Contd)

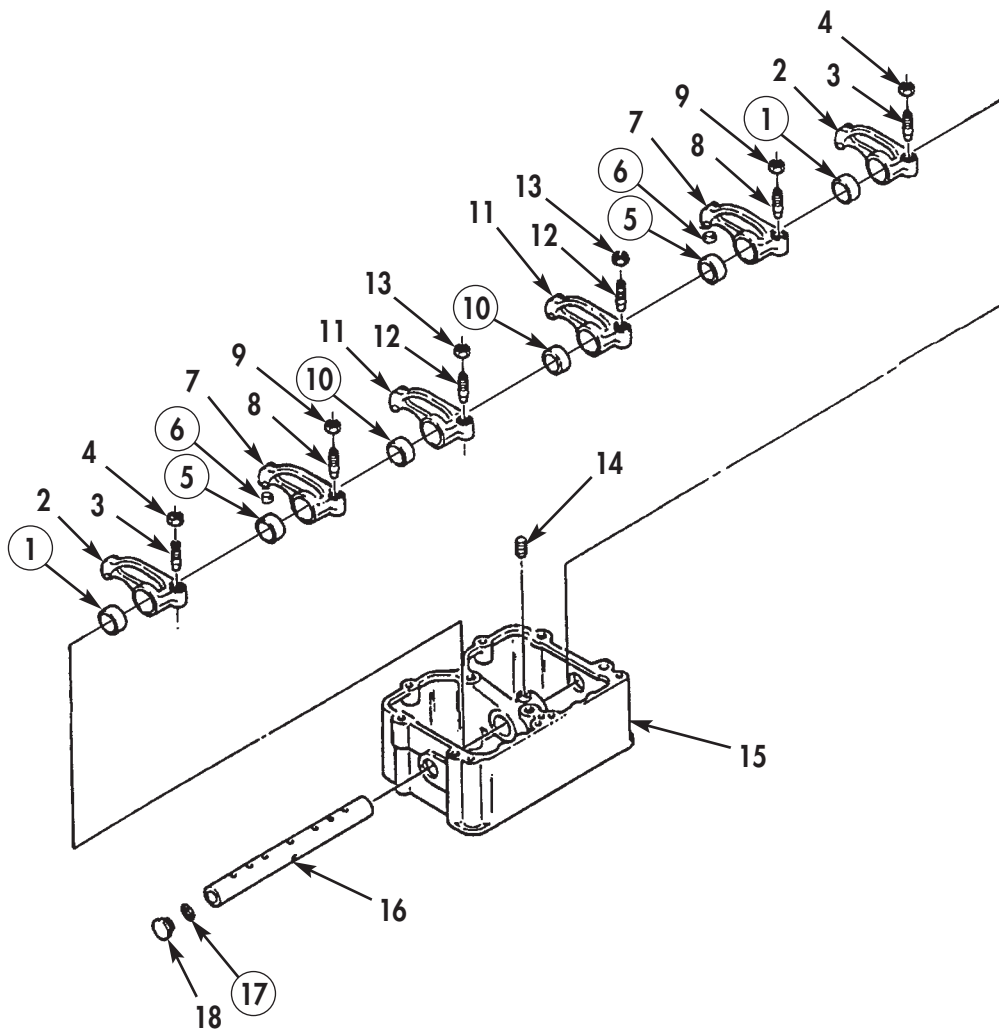


Figure 2. Rocker Levers and Rocker Lever Housing Assembly.

**DIRECT SUPPORT AND GENERAL SUPPORT
MAINTENANCE MANUAL
INCLUDING REPAIR PARTS AND SPECIAL TOOLS LIST (RPSTL)**

FOR

M915, M915A1, M915A4, M916, M920 VEHICLES

NSN 2815-01-082-8125	P/N NTC400-3652-02	CUMMINS NTC-400 BIG CAM I DIESEL ENGINE W/CONTAINER
NSN 2815-01-142-2745	P/N 11669835	CUMMINS NTC-400 BIG CAM III DIESEL ENGINE W/CONTAINER

OIL COOLER

DISASSEMBLY, CLEANING AND INSPECTION, ASSEMBLY

INITIAL SETUP:

Tools and Special Tools

General mechanic's tool kit: automotive
(Item 1, WP 0061 00)
Maintenance and repair shop equipment:
automotive (Item 2, WP 0061 00)
Automotive maintenance and repair
supplemental set no. 2 (Item 3, WP 0061 00)

Materials/Parts

Pipe sealant (Item 25, WP 0060 00)
Lubricating oil, OE/HDO 30
(Item 20, WP 0060 00)
Twelve lockwashers
(Item 1, Table 6, WP 0062 00)
O-ring (Item 2, Table 6, WP 0062 00)
Gasket (Item 3, Table 6, WP 0062 00)
Gasket (Item 4, Table 6, WP 0062 00)
Spring (Item 5, Table 6, WP 0062 00)
Spring (Item 6, Table 6, WP 0062 00)
Gasket (Item 7, Table 6, WP 0062 00)
O-ring (Item 8, Table 6, WP 0062 00)
Oil cooler core (Item 9, Table 6, WP 0062 00)
Vent valve (Item 10, Table 6, WP 0062 00)
Lockwasher (Item 11, Table 6, WP 0062 00)
Gasket (Item 12, Table 6, WP 0062 00)
Spring (Item 13, Table 6, WP 0062 00)
Gasket (Item 14, Table 6, WP 0062 00)
Two retaining rings
(Item 15, Table 6, WP 0062 00)

Materials/Parts (Contd)

Two O-rings (Item 16, Table 6, WP 0062 00)
Element (Item 17, Table 6, WP 0062 00)
Spring (Item 18, Table 6, WP 0062 00)
Lockwasher (Item 19, Table 6, WP 0062 00)
Gasket (Item 20, Table 6, WP 0062 00)
O-ring (Item 21, Table 6, WP 0062 00)

Equipment Condition

Oil cooler removed from engine (WP 0009 00).

OIL COOLER (Contd)

BIG CAM I DISASSEMBLY

1. For removal of oil cooler, refer to WP 0009 00.
2. Remove pipe plug (7) and vent valve (10) from oil cooler rear cover (3). Discard vent valve.
3. Remove two pipe plugs (16) from oil cooler front cover (14).
4. Remove expansion plug (31) or elbow (30) from oil cooler housing (12).
5. Remove screw (24), lockwasher (25), washer (26), head (27), gasket (28), and O-ring (29) from oil cooler housing (12). Discard lockwasher (25), gasket (28), and O-ring (29).
6. Remove seat (23), disc (22), and spring (21) from oil cooler housing (12). Discard spring (21).
7. Remove plug (21), spacer (22), spring (21), and plunger (18) from oil cooler front cover (14). Discard spring (19).
8. Remove six screws (15), lockwashers (8), oil cooler front cover (14), and gasket (13) from oil cooler housing (12). Discard lockwashers (8) and gasket (13).
9. Remove six screws (2) and (9), four lockwashers (8), bracket (1), oil cooler rear cover (3), and gasket (11) from oil cooler housing (12). Discard lockwashers (8) and gasket (11).
10. Remove two retaining rings (4), O-rings (5), and element (6) from oil cooler housing (12). Discard O-rings (5) retaining rings and, element (6).

OIL COOLER (Contd)

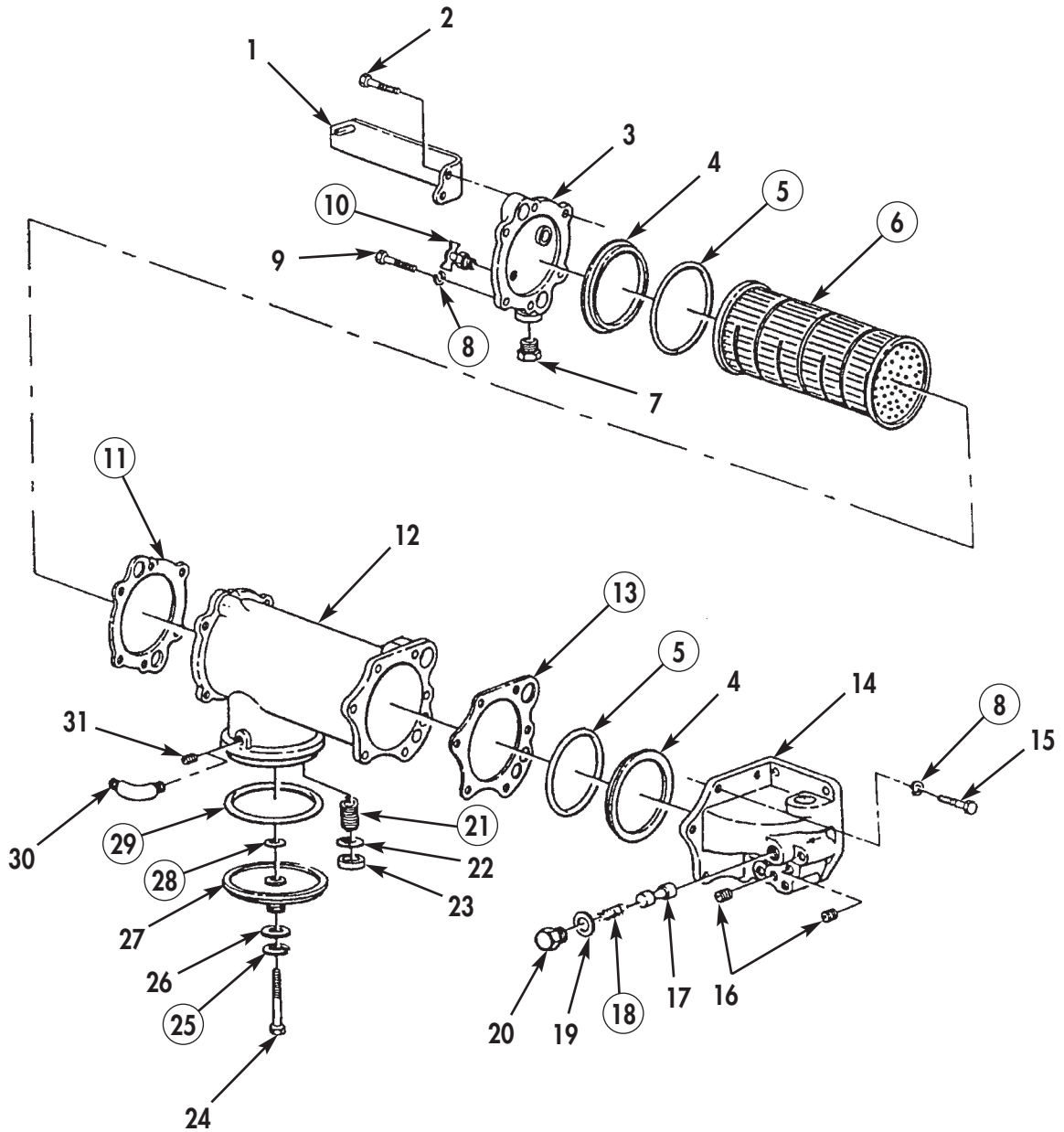


Figure 1. Oil Cooler Disassembly—Big Cam I Engine.

OIL COOLER (Contd)

BIG CAM III DISASSEMBLY

1. For removal of oil cooler, refer to WP 0009 00.
2. Remove adapter (25) from head (12).
3. Remove three screws (9), lockwashers (3), washers (10), and bracket (11) from head (12). Discard lockwashers (3).
4. Remove three screws (27), lockwashers (3), washers (26), head (12), O-ring (13), and gasket (14) from oil cooler housing (15). Discard lockwashers (3), O-ring (13), and gasket (14).
5. Remove spring (24), bypass valve piston (23), spring (22), bypass valve plunger (21), and pressure sensing piston (20) from oil cooler housing (15). Discard spring (22) and (24).
6. Remove six screws (16), lockwashers (3), washers (17), support (7), and gasket (2) from oil cooler housing (15). Discard lockwashers (3) and gasket (2).
7. Remove oil cooler core (1) and gasket (18) from oil cooler housing (15). Discard gasket (18) and oil cooler core (1).
8. Remove two screws (4), lockwashers (3), valve (5), and O-ring (6) from support (7). Discard lockwashers (3) and O-ring (6).
9. Remove two pipe plugs (8) from support (7).
10. Remove adapter (19) from oil cooler housing (15).

OIL COOLER (Contd)

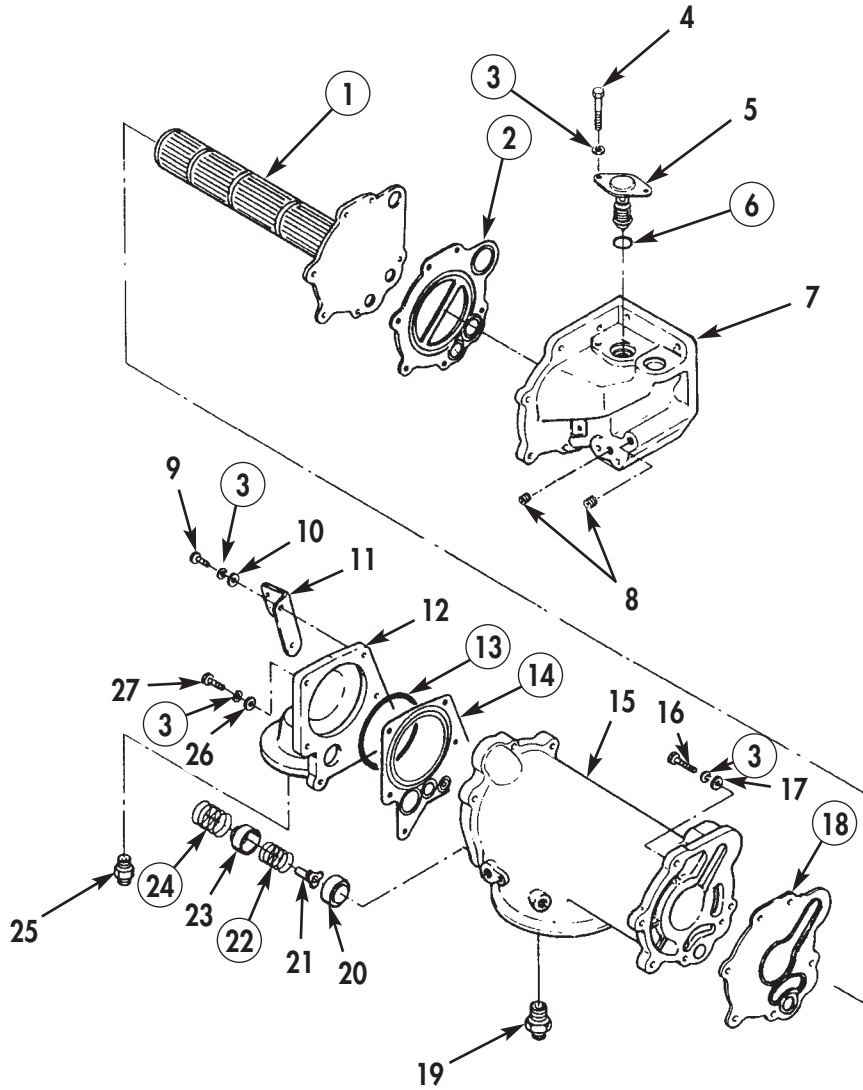


Figure 2. Oil Cooler Disassembly—Big Cam III Engine.

OIL COOLER (Contd)

CLEANING AND INSPECTION

1. For general parts cleaning information, refer to CLEANING, WP 0051 00.
2. For general parts inspection information, refer to INSPECTION, WP 0051 00.

NOTE

Replace any part that does not pass visual inspection or is outside specified wear limits.

Perform step 3 for Big Cam I only.

3. Inspect oil cooler rear cover (1), oil cooler housing (2), and oil cooler front cover (3) for cracks, plugged oil passages, and stripped threads or damaged holes. Repair all stripped threads.

NOTE

Perform step 4 for Big Cam III only.

4. Inspect head (4), oil cooler housing (5), and support (6) for cracks, plugged oil passages, and stripped threads or damaged holes. Repair all stripped threads.

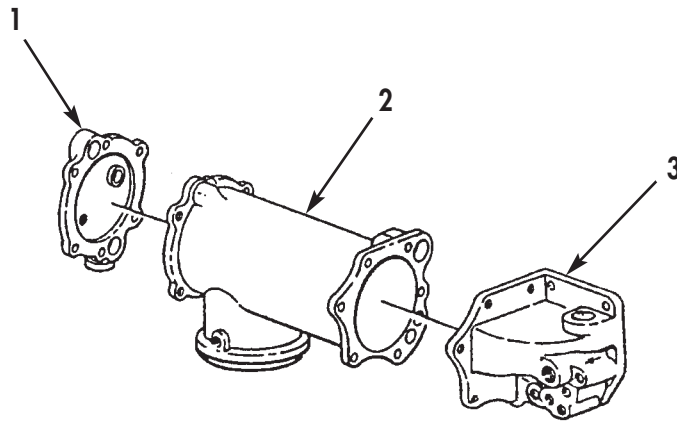
OIL COOLER (Contd)

Figure 3. Oil Cooler Cleaning and Inspection—Big Cam I Engine.

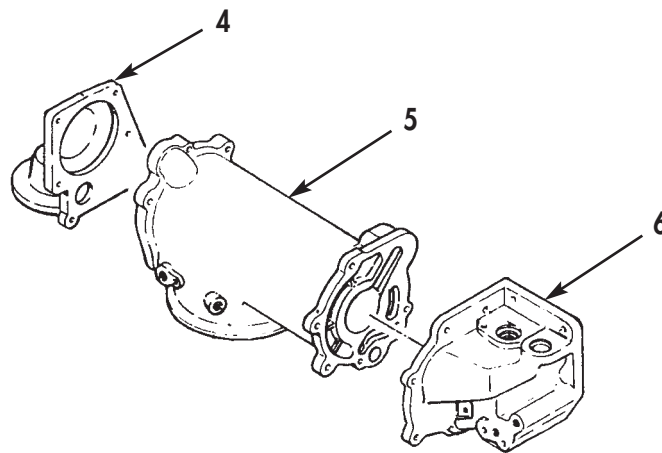


Figure 4. Oil Cooler Cleaning and Inspection—Big Cam III Engine.

OIL COOLER (Contd)

BIG CAM III ASSEMBLY

1. Install adapter (19) in oil cooler housing (15).
2. Apply pipe sealant on two pipe plugs (8) and install in support (7). Tighten pipe plugs (8) 60–84 lb-in. (7–10 N•m).
3. Apply OE/HDO 30 lubricating oil to new O-ring (6). Install O-ring (6) and valve (5) in support (7) with two new lockwashers (3) and screws (4). Tighten screws (4) 30–35 lb-ft (41–48 N•m).
4. Install new gasket (18), new oil cooler core (1), new gasket (2), and support (7) on oil cooler housing (15) with six washers (17), new lockwashers (13), and screws (16). Tighten screws (16) 30–35 lb-ft (41–48 N•m).
5. Install pressure sensing piston (20), bypass valve plunger (21), new spring (22), bypass valve piston (23), and new spring (24) in oil cooler housing (15).
6. Apply OE/HDO 30 lubricating oil to new O-ring (13) and install new gasket (14), O-ring (13), and head (12) on oil cooler housing (15) with three washers (26), new lockwashers (3), and screws (27). Do not tighten screws (27).
7. Install bracket (11) on head (12) with three washers (10), new lockwashers (3), and screws (9). Tighten screws (9) and (30) 30–35 lb-ft (41–48 N•m).
8. Install adapter (25) in head (12).
9. For installation of oil cooler, refer to WP 0046 00.

OIL COOLER (Contd)

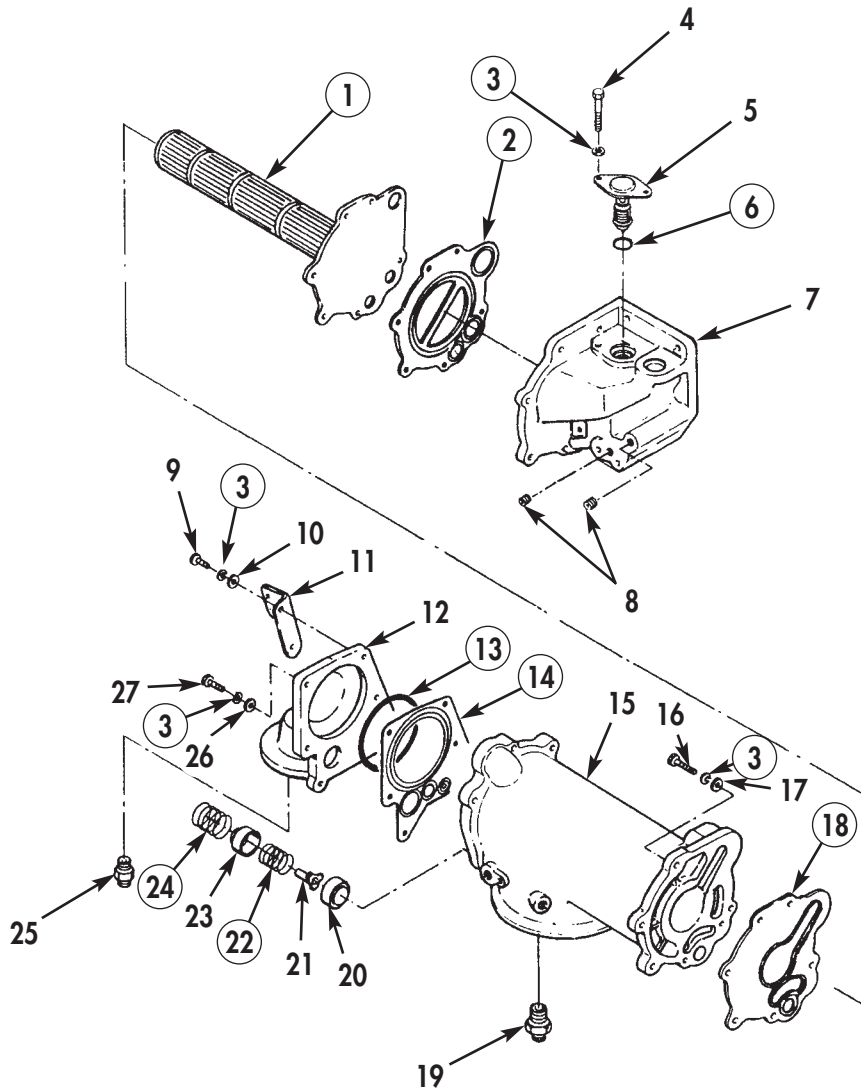


Figure 5. Oil Cooler Assembly—Big Cam III Engine.

OIL COOLER (Contd)

BIG CAM I ASSEMBLY

1. Apply OE/HDO 30 lubricating oil to two new O-rings (5) and install on new element (6).
2. Align element (6) to oil cooler housing (12) and install in oil cooler housing (12). Ensure O-rings (5) are not pinched or twisted.
3. Install two new retaining rings (4) in oil cooler housing (12).
4. Install new gasket (11), oil cooler rear cover (3), and bracket (1) on oil cooler housing (12) with four new lockwashers (8) and six screws (2) and (9). Tighten screws (2) and (9) 30–35 lb-ft (41–48 N•m).
5. Install new gasket (13) and oil cooler front cover (14) on oil cooler housing (12) with six new lockwashers (8) and screws (15). Tighten screws (15) 30–35 lb-ft (41–48 N•m).
6. Install plunger (17), new spring (18), spacer (19), and plug (20) in oil cooler front cover (14).
7. Install new spring (21), disc (22), and seat (23) in oil cooler housing (12).
8. Apply OE/HDO 30 lubricating oil on new O-ring (29) and install in oil cooler housing (12).
9. Install new gasket (28) and head (27) on oil cooler housing (12) with washer (26), new lockwasher (25), and screw (24).
10. Install expansion plug (32) or elbow (31) on oil cooler housing (12).
11. Apply pipe sealant on two pipe plugs (17) and install in oil cooler front cover (14).
12. Apply pipe sealant on pipe plug (7) and new vent valve (10) and install in oil cooler rear cover (3).
13. For installation of oil cooler, refer to WP 0046 00.

OIL COOLER (Contd)

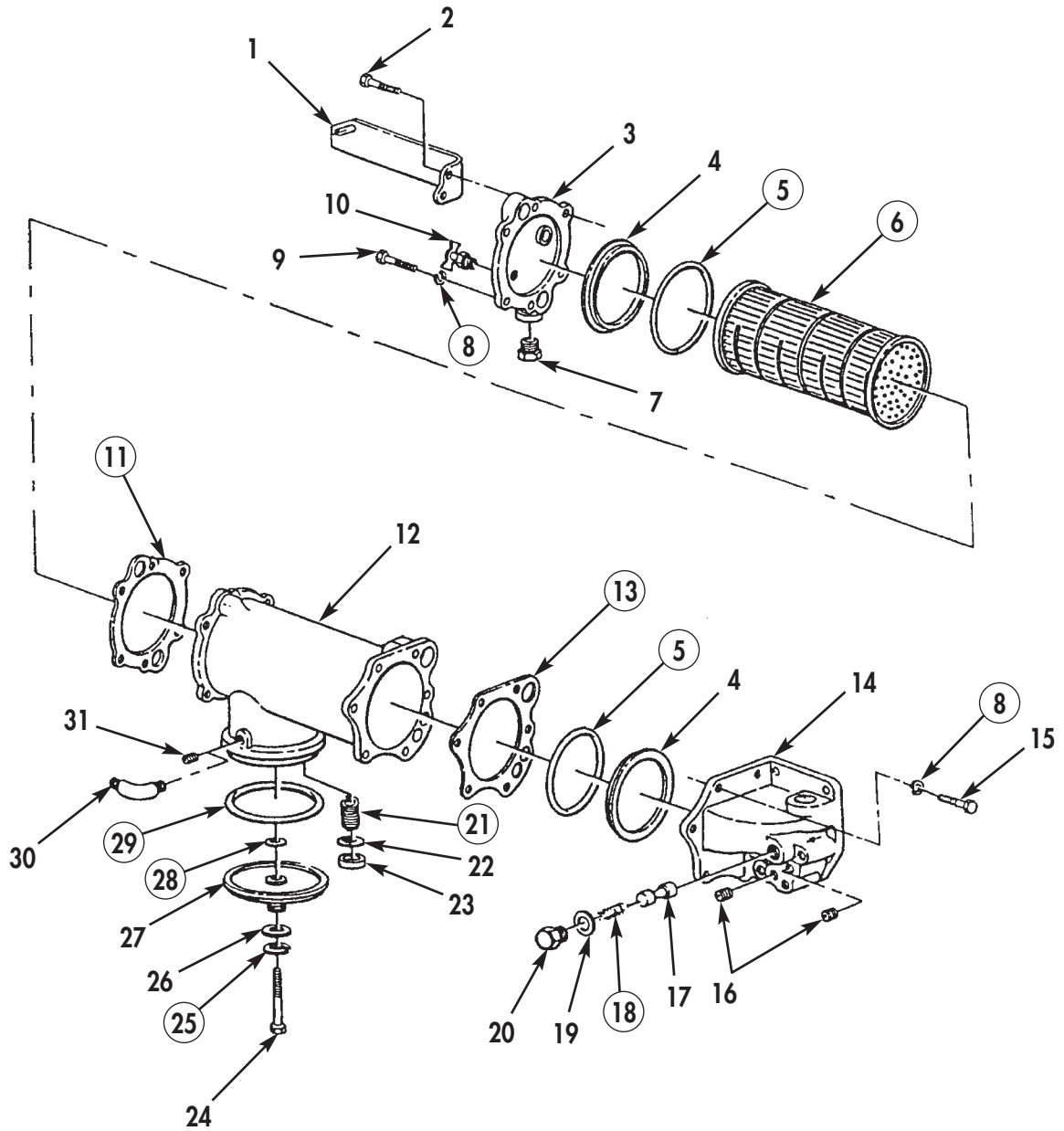


Figure 6. Oil Cooler Assembly—Big Cam I Engine.

END OF WORK PACKAGE

0021 00-11/12 blank

**DIRECT SUPPORT AND GENERAL SUPPORT
MAINTENANCE MANUAL
INCLUDING REPAIR PARTS AND SPECIAL TOOLS LIST (RPSTL)**

FOR

M915, M915A1, M915A4, M916, M920 VEHICLES

NSN 2815-01-082-8125	P/N NTC400-3652-02	CUMMINS NTC-400 BIG CAM I DIESEL ENGINE W/CONTAINER
NSN 2815-01-142-2745	P/N 11669835	CUMMINS NTC-400 BIG CAM III DIESEL ENGINE W/CONTAINER

**OIL PAN, DIPSTICK, OIL SUCTION TUBES, AND BREATHER TUBE
DISASSEMBLY, CLEANING AND INSPECTION, ASSEMBLY**

INITIAL SETUP:

Tools and Special Tools

General mechanic's tool kit: automotive
(Item 1, WP 0061 00)
Maintenance and repair shop equipment:
automotive (Item 2, WP 0061 00)
Automotive maintenance and repair
supplemental set no. 2 (Item 3, WP 0061 00)

Equipment Condition

Oil pan, dipstick, oil suction tubes, and
breather tube removed from engine
(WP 0012 00).

OIL PAN, DIPSTICK, OIL SUCTION TUBES, AND BREATHER TUBE (Contd)

DISASSEMBLY

NOTE

Perform steps 1 and 2 for Big Cam I only.

1. Remove two plugs (2) and one spacer (3) from oil pan (1).
2. Remove four screws (4) and strainer element (5) from oil pan (1).

NOTE

Perform steps 3 through 5 for Big Cam III only.

3. Remove washer (10) and nut (11) from oil pan (12).
4. Remove clamp (9) and oil suction tube (8) from oil pan (12).
5. Remove three pipe plugs (6), two plugs (7), and one spacer (13) from oil pan (12).

CLEANING AND INSPECTION

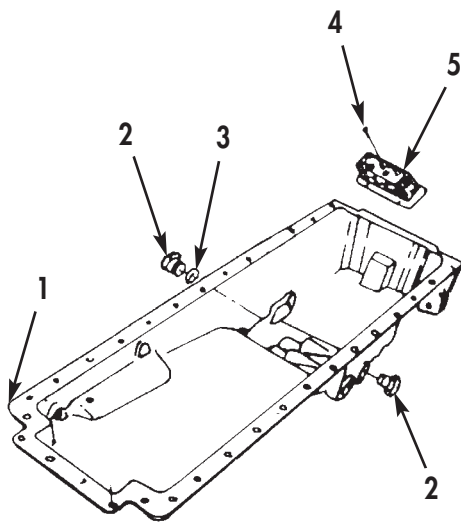
1. For general parts cleaning information, refer to CLEANING, WP 0051 00.
2. For general parts inspection information, refer to INSPECTION, WP 0051 00.

NOTE

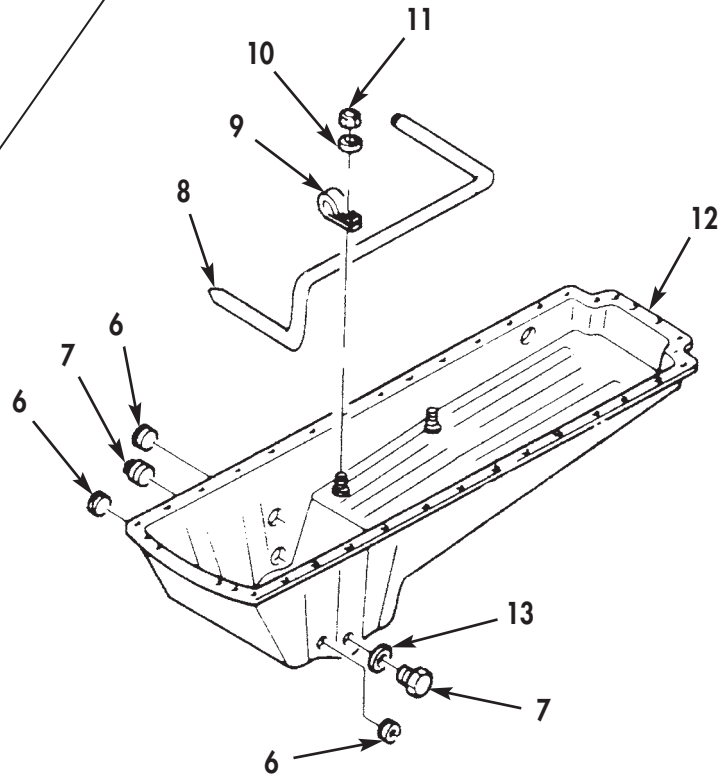
Replace any part that does not pass visual inspection or is outside specified wear limits.

3. Inspect oil pan (12) and (1) for cracks, corrosion, warpage, and stripped or damaged threads. Repair damaged threads as necessary.
4. Inspect plugs (2), (6), and (7) for stripped or damaged threads. Replace any damaged plug.
5. Inspect strainer element (5) for damage. Replace strainer element (5) if damaged.

OIL PAN, DIPSTICK, OIL SUCTION TUBES, AND BREATHER TUBE (Contd)



**BIG CAM I OIL PAN
(CAST ALUMINUM)**



**BIG CAM III OIL PAN
(STAMPED STEEL)**

Figure 1. Oil Pan Disassembly.

OIL PAN, DIPSTICK, OIL SUCTION TUBES, AND BREATHER TUBE (Contd)

CLEANING AND INSPECTION (Contd)

6. Inspect oil level dipstick (2) and oil level dipstick tube (1) for cracks, bends, dents, and corrosion. Discard oil level dipstick (2) or oil level dipstick tube (1) if damaged.

NOTE

Perform step 7 for Big Cam I only.

7. Inspect oil suction tube (3) for cracks, bends, dents, corrosion, or rubbing marks caused by vibration. Replace oil suction tube (3) if damaged.

NOTE

Perform step 8 for Big Cam III only.

8. Inspect oil suction tube (4) and fitting (5) for cracks, bends, dents, and corrosion. Replace oil suction tube (4) or fitting (5) if damaged.

NOTE

Perform steps 9 and 10 for Big Cam I only.

9. Inspect breather tube (6) for cracks, bends, dents, and corrosion. Replace breather tube (6) if damaged.
10. Inspect breather hose (7) for rubbing marks caused by vibration, swelling, or cracks. Replace breather hose (7) if damaged.

NOTE

Perform steps 11 and 12 for Big Cam III only.

11. Inspect breather tubes (9) and (12) and aftercooler bracket (8) for cracks, bends, dents, and corrosion. Replace breather tube (9) and (12) or bracket (8) if damaged.
12. Inspect breather hoses (10) and (11) for rubbing marks caused by vibration, swelling, or cracks. Discard breather hose (10) or (11) if damaged.

OIL PAN, DIPSTICK, OIL SUCTION TUBES, AND BREATHER TUBE (Contd)

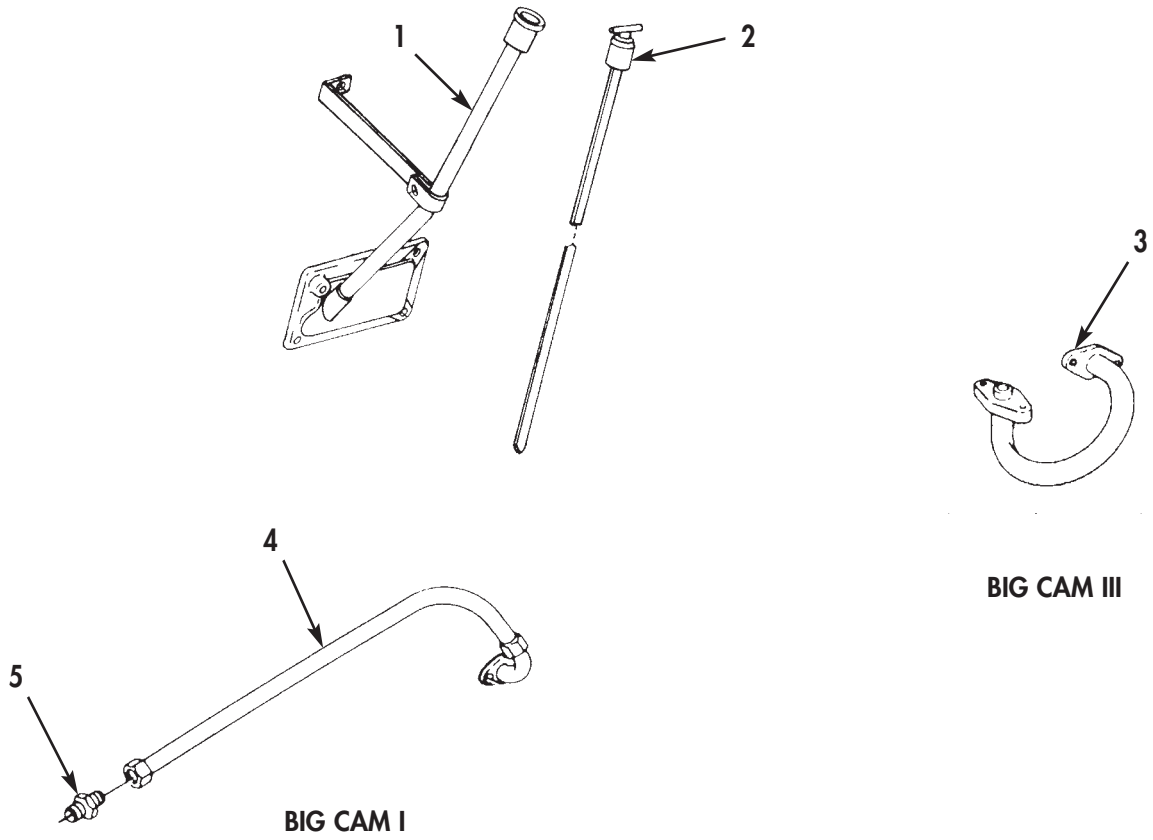


Figure 2. Oil Dipstick, Oil Dipstick Tube, and Oil Suction Tubes Cleaning and Inspection.

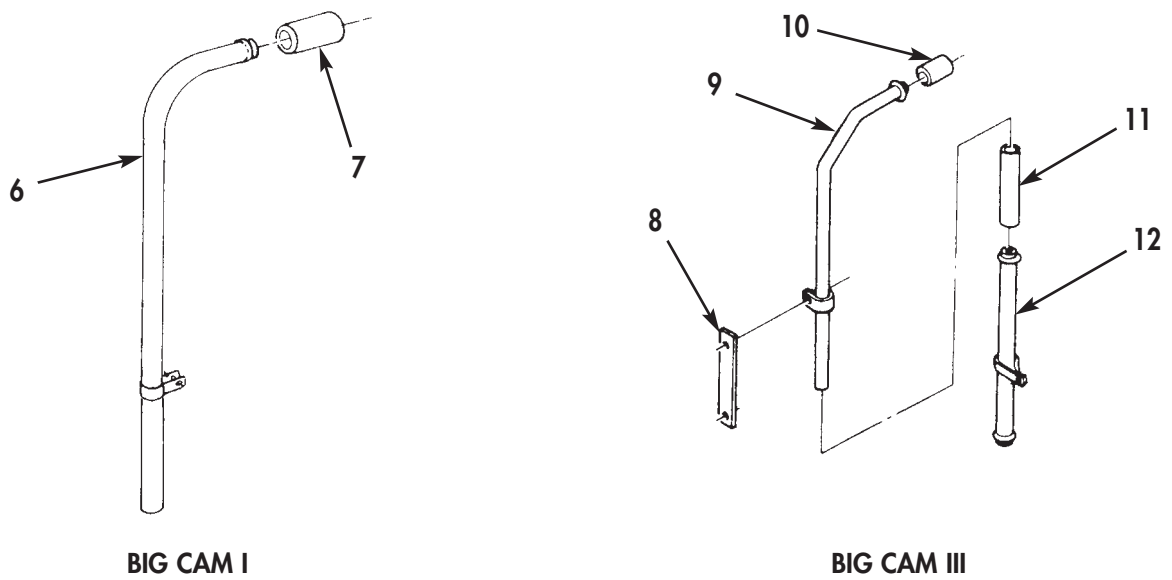


Figure 3. Breather Tube Cleaning and Inspection.

OIL PAN, DIPSTICK, OIL SUCTION TUBES, AND BREATHER TUBE (Contd)

ASSEMBLY

NOTE

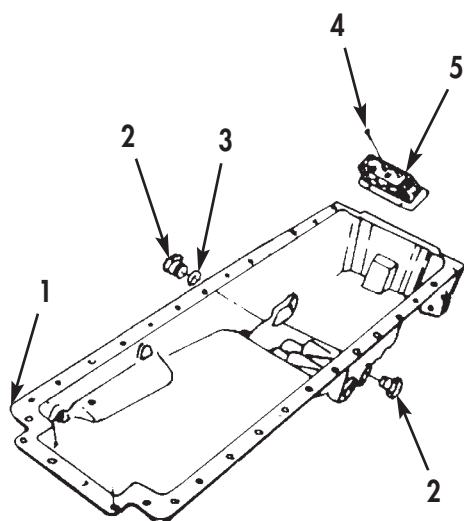
Perform steps 1 and 2 for Big Cam III only.

1. Install oil suction tube (8) and clamp (9) on oil pan (12) and secure with washer (10) and nut (11).
2. Install three pipe plugs (6), one spacer (13), and two plugs (7) on oil pan (12).

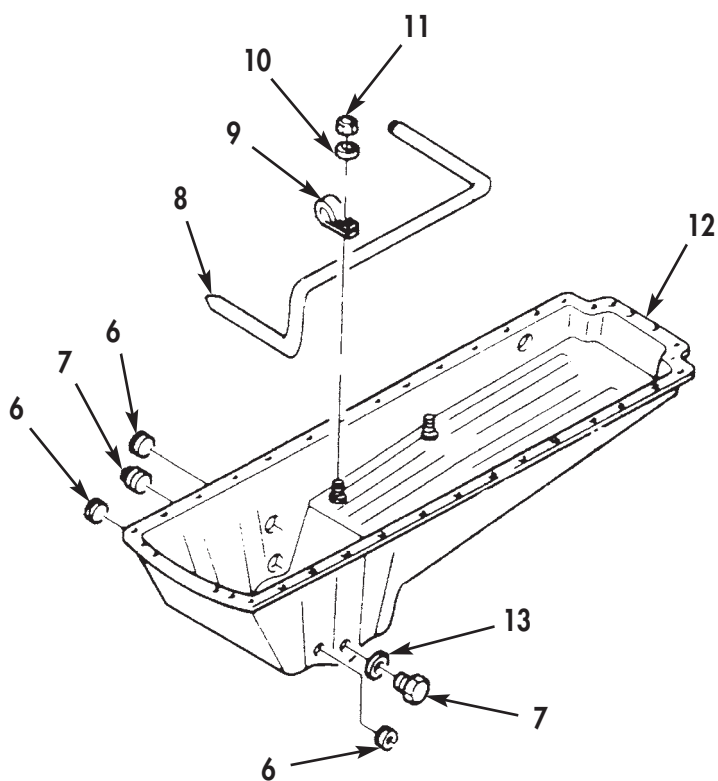
NOTE

Perform steps 3 and 4 for Big Cam I only.

3. Install one spacer (3) and two plugs (2) in oil pan (1).
4. Install strainer element (5) in oil pan (1) with four screws (4).
5. For oil pans (1) and (12), dipstick, oil suction tubes (8), and breather tube installation, refer to WP 0042 00.



**BIG CAM I OIL PAN
(CAST ALUMINUM)**



**BIG CAM III OIL PAN
(STAMPED STEEL)**

Figure 4. Oil Pan Assembly.

END OF WORK PACKAGE

**DIRECT SUPPORT AND GENERAL SUPPORT
MAINTENANCE MANUAL
INCLUDING REPAIR PARTS AND SPECIAL TOOLS LIST (RPSTL)**

FOR

M915, M915A1, M915A4, M916, M920 VEHICLES

NSN 2815-01-082-8125	P/N NTC400-3652-02	CUMMINS NTC-400 BIG CAM I DIESEL ENGINE W/CONTAINER
NSN 2815-01-142-2745	P/N 11669835	CUMMINS NTC-400 BIG CAM III DIESEL ENGINE W/CONTAINER

OIL PUMP

DISASSEMBLY, CLEANING AND INSPECTION, ASSEMBLY

INITIAL SETUP:

Tools and Special Tools

General mechanic's tool kit: automotive
(Item 1, WP 0061 00)
Maintenance and repair shop equipment:
automotive (Item 2, WP 0061 00)
Automotive maintenance and repair
supplemental set no. 2 (Item 3, WP 0061 00)
Gear puller (Item 40, WP 0061 00)
Press
Mandrel (Item 39, WP 0061 00)
Drill press

Materials/Parts (Contd)

Three lockwashers
(Item 10, Table 7, WP 0062 00)
Lockplate (Item 11, Table 7, WP 0062 00)

Equipment Condition

Oil pump removed from engine (WP 0010 00).

Materials/Parts

OE/HDO 10 lubricating oil
(Item 19, WP 0060 00)
Pipe sealant (Item 25, WP 0060 00)
Gasket (Item 1, Table 7, WP 0062 00)
Gasket (Item 2, Table 7, WP 0062 00)
Bushing (Item 3, Table 7, WP 0062 00)
Two bushings (Item 4, Table 7, WP 0062 00)
Two O-rings (Item 5, Table 7, WP 0062 00)
Pressure regulator spring
(Item 6, Table 7, WP 0062 00)
Pressure regulator spring
(Item 7, Table 7, WP 0062 00)
Bushing (Item 8, Table 7, WP 0062 00)
Bypass valve spring
(Item 8, Table 7, WP 0062 00)
Two bushings (Item 9, Table 7, WP 0062 00)

OIL PUMP (Contd)

NOTE

This work package is divided into sections, Big Cam I and Big Cam III engines.

BIG CAM I

Disassembly

1. Using gear puller, remove oil pump drive gear (25) from oil pump driveshaft (11).
2. Remove woodruff key (9) from oil pump driveshaft (11).
3. Remove snapping (20) and coupling (19) from oil pump driveshaft (11).
4. Remove connector (16) from oil pump housing (15).
5. Remove pipe plug (6) from oil pump body (7).

WARNING

Oil pump pressure regulator spring is under tension. Remove oil pump pressure regulator slowly and wear proper eye protection. Failure to do so may result in injury to personnel.

6. Remove screw (1), lockplate (2), retaining yoke (3), pressure regulator spring (4), and plunger (5) from oil pump body (7). Discard lockplate (2) and pressure regulator spring (4).
7. Remove six screws (18), three lockwashers (17), and two washers (21) securing oil pump housing (15) to oil pump body (7). Discard lockwashers (17).
8. Remove oil pump housing (15) and gasket (14) from oil pump body (7). Discard gasket (14).
9. Remove dowel pin (10) from oil pump body (7).
10. Using press, remove oil pump driveshaft (11), with oil pumping gear (12) attached, from oil pump body (7).
11. Using press, remove oil pump driveshaft (11) from oil pumping gear (12).
12. Remove idler gear (23) from idler shaft (24).
13. Using press, remove idler shaft (24) from oil pump body (7).
14. Using press and mandrel, remove bushing (13) from oil pump housing (15). Discard bushing (13).
15. Using press and mandrel, remove two bushings (8) from oil pump body (7). Discard bushings (8).
16. Using press and mandrel, remove bushings (22) from idler gear (23). Discard bushing (24).

Cleaning and Inspection

1. For general parts cleaning information, refer to CLEANING, WP 0051 00.
2. For general parts inspection information, refer to INSPECTION, WP 0051 00.

NOTE

Replace any part that does not pass visual inspection or is outside specified wear limits.

3. Inspect oil pumping gear (12) and idler gear (23) for cracks and stripped or chipped teeth.
4. Inspect oil pump body (7) and oil pump housing (15), for cracks and stripped or elongated threaded bolt holes. Repair all stripped or elongated threaded bolt holes.

OIL PUMP (Contd)

BIG CAM I (Contd)

Cleaning and Inspection (Contd)

5. Inspect dowel pin (10) for cracks or distortion.
6. Inspect coupling (19) for cracks or stripped teeth.
7. Inspect oil pump driveshaft (11) and idler shaft (24) for galling, breaks, cracks, or bends.
8. Using micrometer or equivalent, measure oil pump driveshaft (11) and idler shaft (25) outside diameter. Minimum outside diameter is 0.874 in. (22.20 mm).
9. Inspect woodruff key (9) for damage and woodruff key slot on oil pump driveshaft (11). Replace woodruff key (9) and oil pump driveshaft (11) if woodruff key (9) fits loose in slot.
10. Inspect pressure regulator plunger (5) for movement in bore of oil pump body (7). Replace pressure regulator plunger (5) if it sticks, binds, or is excessively loose.

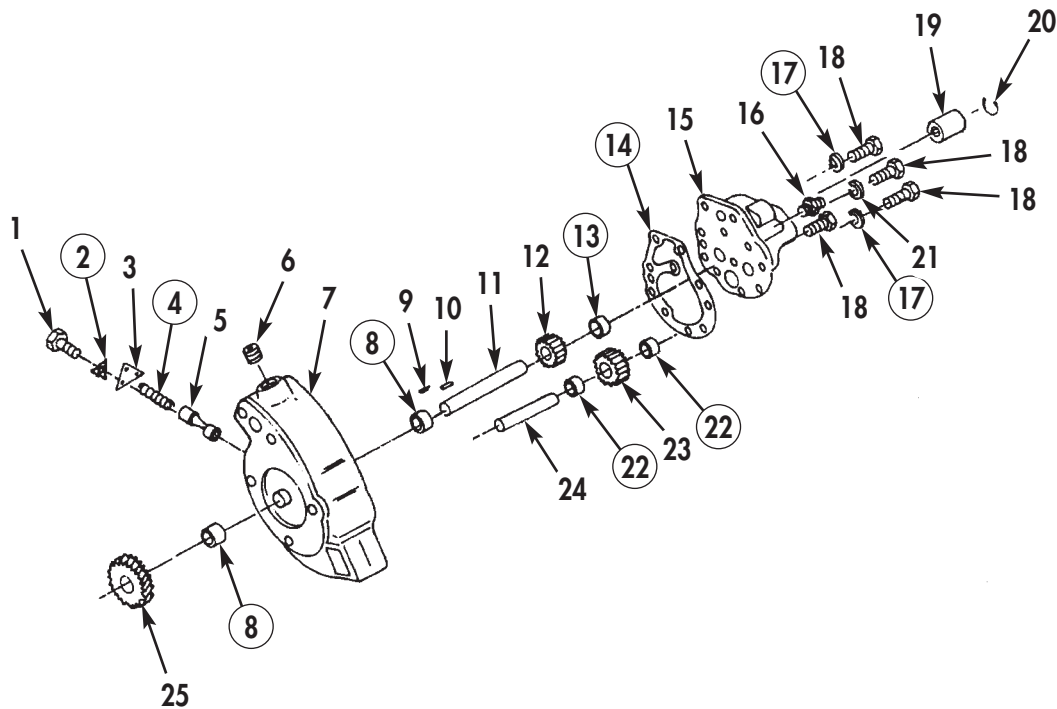


Figure 1. Oil Pump Disassembly—Big Cam I.

OIL PUMP (Contd)

BIG CAM I (Contd)

Assembly

NOTE

Lubricate all parts with OE/HDO 10 lubricating oil before assembly.

New bushings must be line reamed to size before oil pump assembly.

1. Using press and mandrel, install new bushing (22) in idler gear (23). Do not press bushing (22) more than 0.020 in. (0.508 mm) below top surface of idler gear (23). Using drill press and reamer, line-ream inside diameter of bushing (22) to 0.8767–0.8777 in. (22.268–22.293 mm).
2. Using press and mandrel, install two new bushings (8) in oil pump body (7). Do not press bushings (8) more than 0.020 in. (0.508 mm) below top surfaces of oil pump body (7). Using drill press and reamer, line-ream inside diameter of bushings (8) to 0.8767–0.8777 in. (22.268–22.293 mm).
3. Using press and mandrel, install new bushing (13) in oil pump housing (15). Do not press bushing (13) more than 0.020 in. (0.508 mm) below top surfaces of oil pump housing (15). Using drill press and reamer, line-ream inside diameter of bushing (13) to 0.8767–0.8777 in. (22.268–22.293 mm).
4. Using press, install oil pumping gear (12) on oil pump driveshaft (11).
5. Using press, install oil pump driveshaft (11), with oil pumping gear (12) attached, in oil pump body (7) until oil pump driveshaft (11) protrudes 1.035–1.055 in. (26.29–26.80 mm) above oil pump body (7).
6. Using press, install idler shaft (24), with large end facing up, in oil pump body (7) until large end protrudes 0.9375–1.0 in. (23.81–25.40 mm) above oil pump body (7).
7. Install idler gear (23) on idler shaft (24).
8. Using feeler gauge, check clearance from oil pumping gear (12) to oil pump body (7). Clearance should be 0.060–0.070 in. (1.52–1.78 mm). Remove and install oil pumping gear (12) until correct clearance is obtained.
9. Install dowel pin (10) in oil pump body (7).
10. Install new gasket (14) and oil pump housing (15) on oil pump body (7) with two washers (21), three new lockwashers (17), and six screws (18). Tighten screws (18) 35 lb-ft (48 N•m).

WARNING

Oil pump pressure regulator spring is under tension. Install oil pump pressure regulator screw slowly and wear proper eye protection. Failure to do so may result in injury to personnel.

11. Install plunger (5), new pressure regulator spring (4), retaining yoke (3), new lockplate (2), and screw (1), in oil pump body (7). Tighten screw (1) 35 lb-ft (48 N•m).
12. Using pipe sealant, install pipe plug (6) in oil pump body (7). Tighten plug (6) 30 lb-ft (41 N•m).
13. Install connector (16) on oil pump housing (15).

OIL PUMP (Contd)**BIG CAM I (Contd)****Assembly (Contd)**

14. Install coupling (19) and snapping (20) on oil pump driveshaft (11).
15. Install woodruff key (9) in oil pump driveshaft (11).
16. Using press, install oil pump drive gear (25) on oil pump driveshaft (11).
17. Using a dial indicator, check oil pump driveshaft (11) end play. End play should be 0.002–0.008 in. (0.05–0.20 mm).
18. For oil pump installation, refer to WP 0042 00.

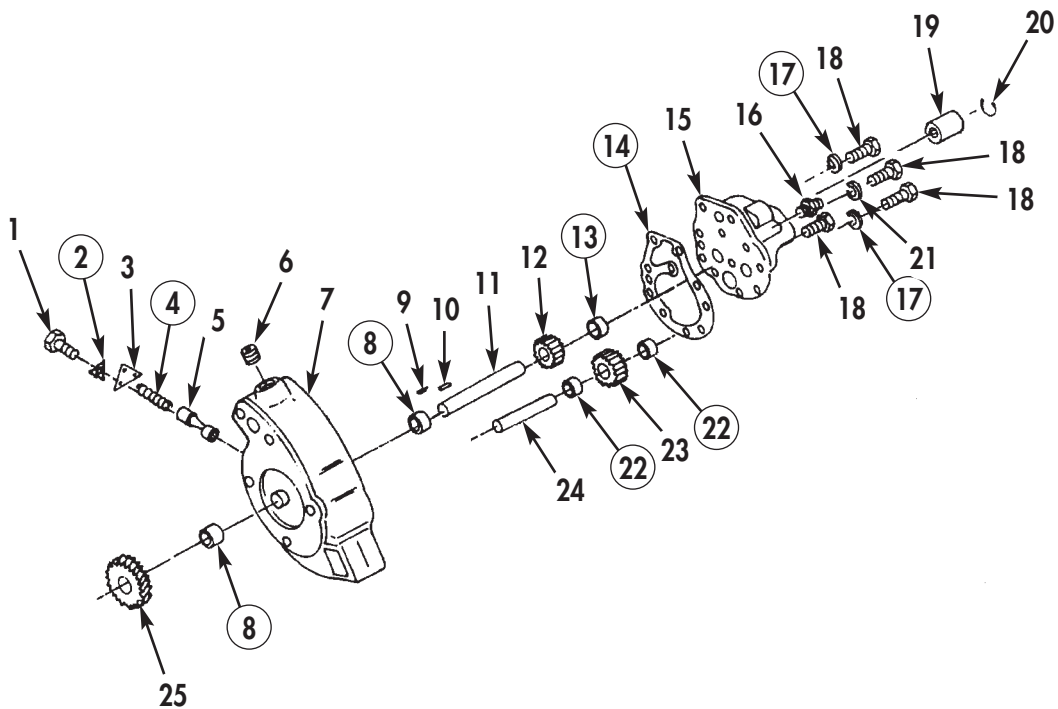


Figure 2. Oil Pump Assembly—Big Cam I.

OIL PUMP (Contd)

BIG CAM III

Disassembly

1. For oil pump removal, refer to WP 0010 00.
2. Using gear puller, remove oil pump drive gear (1) from oil pump driveshaft (10).
3. Remove woodruff key (9) from oil pump driveshaft (10).
4. Remove retaining ring (17) and coupling (16) from oil pump driveshaft (10).
5. Remove pipe plug (15) from oil pump cover (14).

WARNING

Oil pump pressure regulator spring is under tension. Remove oil pump bypass screw slowly and wear proper eye protection. Failure to do so may result in injury to personnel.

6. Remove screw (27), washer (26), retainer (25), pressure regulator spring (23), and plunger (22) from oil pump body (3). Discard pressure regulator spring (24).
7. Remove two O-rings (24) from retainer (25). Discard O-rings (24).
8. Remove seven screws (18), oil pump cover (14), and gasket (13) from oil pump body (3). Discard gasket (13).
9. Remove dowel pin (8) from oil pump body (3).
10. Remove bypass valve seat (7), bypass valve disc (6), washer (5), and bypass valve spring (4) from oil pump body (3). Discard bypass valve spring (4).
11. Using press, remove oil pump driveshaft (10), with oil pumping gear (11) attached, from oil pump body (3).
12. Using press, remove oil pump driveshaft (10), from oil pumping gear (11).
13. Remove idler gear (20) from idler shaft (21).
14. Using press, remove idler shaft (21) from oil pump body (3).
15. Using press and mandrel, remove two bushings (2) from oil pump body (3). Discard bushings (2).
16. Using press and mandrel, remove bushing (12) from oil pump cover (14). Discard bushings (12) and (19).
17. Using press and mandrel, remove two bushings (21) from idler gear (20). Discard bushing (21).

Cleaning and Inspection

1. For general parts cleaning information, refer to CLEANING, WP 0051 00.
2. For general parts inspection information, refer to INSPECTION, WP 0051 00.

NOTE

Replace any part that does not pass visual inspection or is outside specified wear limits.

3. Inspect oil pump drive gear (11) and idler gear (20) for cracks and stripped or chipped teeth.
4. Inspect oil pump body (3) and oil pump cover (14) for cracks and stripped or elongated threaded bolt holes. Repair all stripped or elongated threaded bolt holes.
5. Inspect dowel pin (8) for cracks or distortion.

OIL PUMP (Contd)**BIG CAM III (Contd)****Cleaning and Inspection (Contd)**

6. Inspect coupling (16) for cracks or stripped teeth.
7. Inspect oil pump driveshaft (10) and idler shaft (21) for galling, breaks, cracks, or bends.
8. Using micrometer or equivalent, measure oil pump driveshaft (10) and idler shaft (21) outside diameter. Minimum outside diameter is 0.874 in (22.20 mm).
9. Inspect woodruff key (9) for damage and woodruff key slot on oil pump driveshaft (10). Replace woodruff key (9) and oil pump driveshaft (10) if woodruff key (9) fits loose in slot.
10. Inspect pressure regulator plunger (22) for movement in bore of oil pump body (3). Replace pressure regulator plunger (22) if it sticks, binds, or is excessively loose.
11. Inspect bypass valve disc (6) for movement in bore of oil pump body (3). Replace bypass valve disc (6) if it sticks, binds, or is excessively loose.

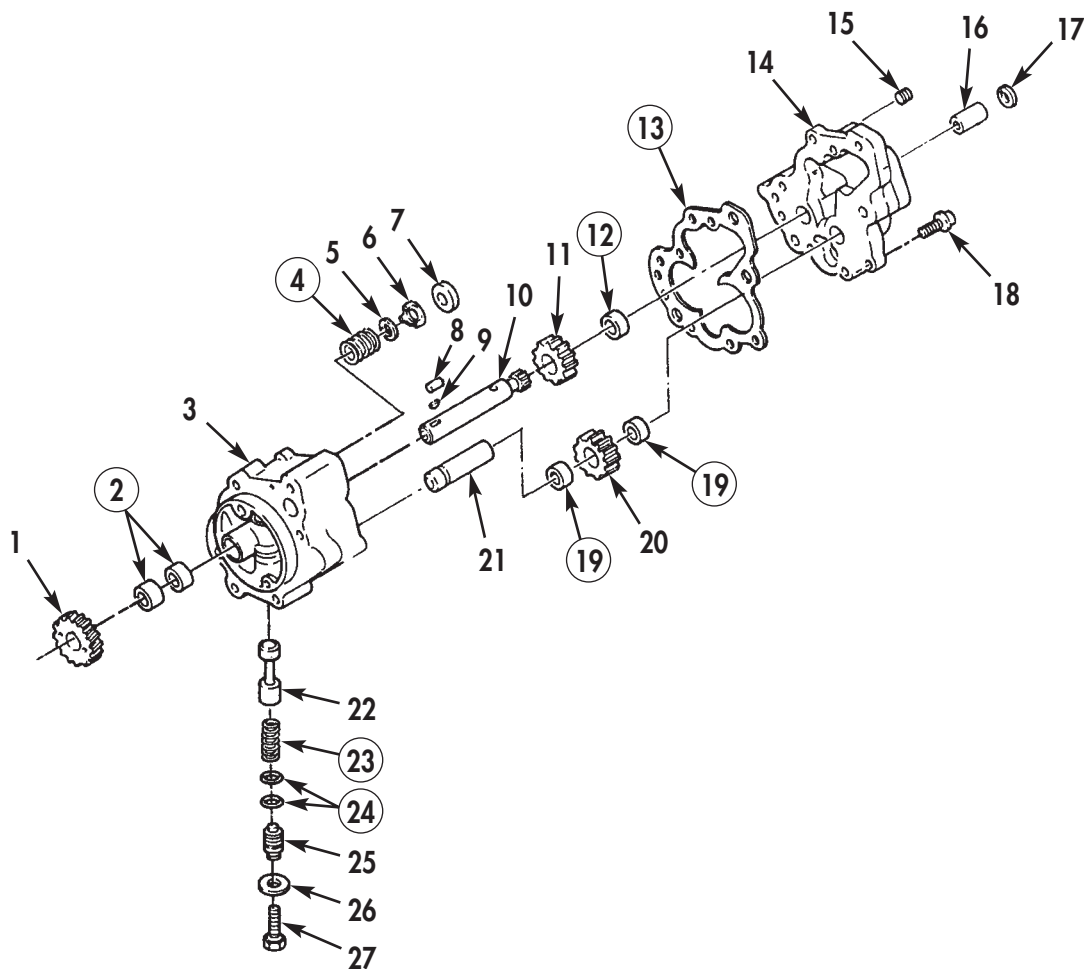


Figure 3. Oil Pump Disassembly—Big Cam III.

OIL PUMP (Contd)

BIG CAM III (Contd)

Assembly

NOTE

Lubricate all parts with OE/HDO 10 lubricating oil before assembly.

New bushings must be line reamed to size before oil pump assembly.

1. Using press and mandrel, install two new bushings (5) and (19) in idler gear (20). Do not press bushing (19) more than 0.020 in. (0.508 mm) below top surface of idler gear (20). Using drill press and reamer, line-ream inside diameter of bushing (19) to 0.8767–0.8777 in. (22.268–22.293 mm).
2. Using press and mandrel, install two new bushings (2) in oil pump body (3). Do not press bushings (2) more than 0.020 in. (0.508 mm) below top surfaces of oil pump body (3). Using drill press and reamer, line-ream inside diameter of bushings (2) to 0.8767–0.8777 in. (22.268–22.293 mm).
3. Using press and mandrel, install new bushing (12) in oil pump cover (14). Do not press bushing (12) more than 0.020 in. (0.508 mm) below top surfaces of oil pump cover (14). Using drill press and reamer, line-ream inside diameter of bushing (12) to 0.8767–0.8777 in. (22.268–22.293 mm).
4. Using press, install oil pumping gear (11) on oil pump driveshaft (10).
5. Using press, install oil pump driveshaft (10) with oil pumping gear (11) attached, in oil pump body (3) until oil pump driveshaft (10) protrudes 1.035–1.055 in. (2.629–2.680 cm) above oil pump body (3).
6. Using press, install idler shaft (21) with large end facing up, in oil pump body (3) until large end protrudes 0.9375–1.0 in. (23.81–25.40 mm) above oil pump body (3).
7. Install idler gear (20) on idler shaft (21).
8. Using feeler gauge, check oil pumping gear (11) to oil pump body (3) clearance. Clearance should be 0.060–0.070 in. (1.52–1.78 mm). Remove and install oil pumping gear (11) until correct clearance is obtained.
9. Install new bypass spring (4), washer (5), bypass valve disc (6), and bypass valve seat (7) in oil pump body (3).
10. Install dowel pin (9) in oil pump body (3).
11. Install new gasket (13) and oil pump cover (14) on oil pump body (3) with seven screws (18). Tighten screws (18) 35 lb-ft (48 N•m).
12. Install two new O-rings (24) on retainer (25).

WARNING

Oil pump pressure regulator spring is under tension. Install oil pump pressure regulator screw slowly and wear proper eye protection. Failure to do so may result in injury to personnel.

13. Install plunger (22), new pressure regulator spring (23), retainer (25), washer (26), and screw (27) in oil pump body (3).

OIL PUMP (Contd)**BIG CAM III (Contd)****Assembly (Contd)**

14. Using pipe sealant, install pipe plug (15) in oil pump cover (14). Tighten plug (15) 30 lb-ft (41 N·m).
15. Install coupling (16) and snapping (17) on oil pump driveshaft (10).
16. Install woodruff key (9) in oil pump driveshaft (10).
17. Using press, install oil pump drive gear (1) on oil pump driveshaft (10).
18. Using a dial indicator, check oil pump driveshaft (10) end play. End play should be between 0.002–0.008 in. (0.05–0.20 mm).
19. For oil pump installation, refer to WP 0042 00.

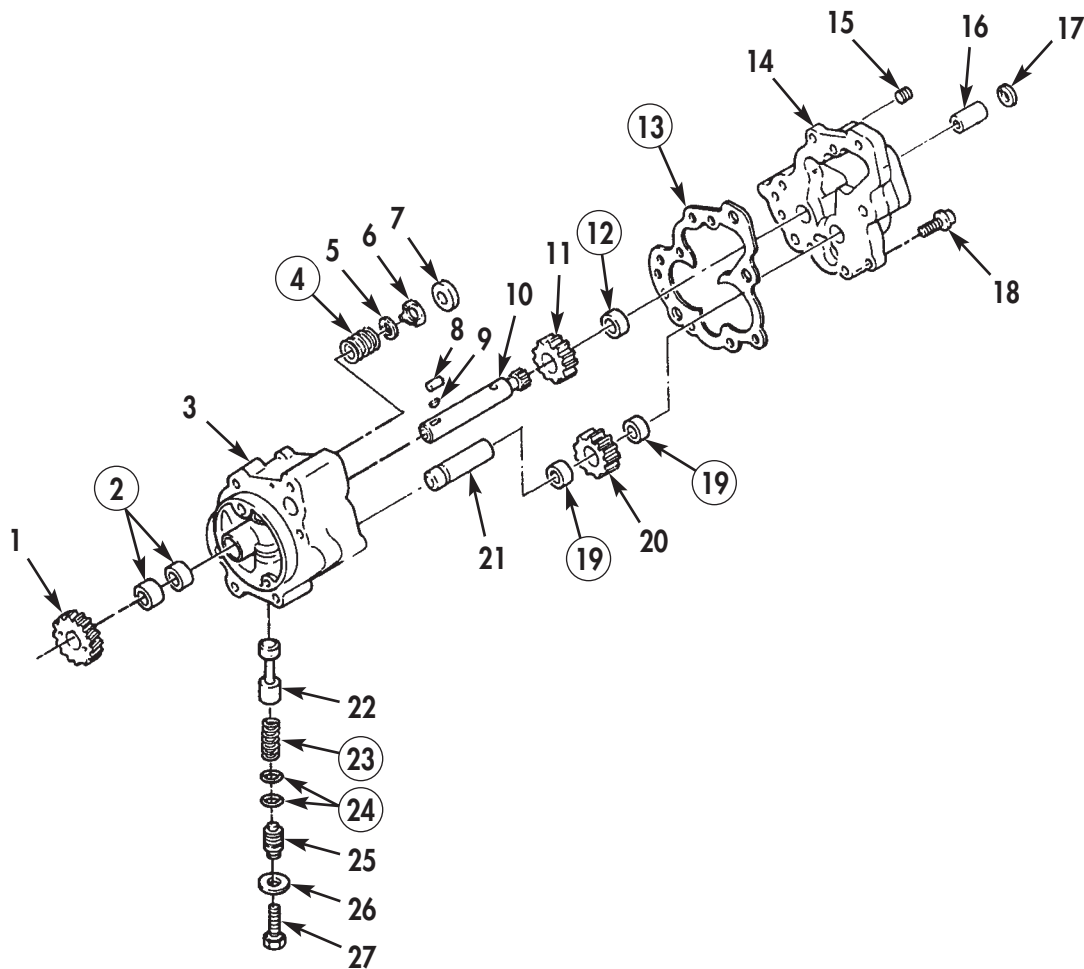


Figure 4. Oil Pump Assembly—Big Cam III.

END OF WORK PACKAGE

0023 00-9/10 blank

**DIRECT SUPPORT AND GENERAL SUPPORT
MAINTENANCE MANUAL
INCLUDING REPAIR PARTS AND SPECIAL TOOLS LIST (RPSTL)**

FOR

M915, M915A1, M915A4, M916, M920 VEHICLES

NSN 2815-01-082-8125	P/N NTC400-3652-02	CUMMINS NTC-400 BIG CAM I DIESEL ENGINE W/CONTAINER
NSN 2815-01-142-2745	P/N 11669835	CUMMINS NTC-400 BIG CAM III DIESEL ENGINE W/CONTAINER

AIR AFTERCOOLER

DISASSEMBLY, CLEANING AND INSPECTION, ASSEMBLY

INITIAL SETUP:

Tools and Special Tools

General mechanic's tool kit:
automotive (Item 1, WP 0061 00)
Maintenance and repair shop equipment:
automotive (Item 2, WP 0061 00)
Automotive maintenance and repair
supplemental set no. 2 (Item 3, WP 0061 00)
Air pressure tester (Item 4, WP 0061 00)

Equipment Condition

Air aftercooler removed from engine
(WP 0010 00).

Materials/Parts

OE/HDO 10 lubricating oil
(Item 19, WP 0060 00)
Gasket (Item 1, Table 8, WP 0062 00)
Gasket (Item 2, Table 8, WP 0062 00)
Gasket (Item 3, Table 8, WP 0062 00)
Four O-rings (Item 4, Table 8, WP 0062 00)

AIR AFTERCOOLER (Contd)

DISASSEMBLY

NOTE

This procedure covers air aftercooler repair for Big Cam I and Big Cam III engines. Big Cam III water outlet may be equipped with lockwashers. Discard lockwashers if equipped.

1. Remove three screws (4), washers (3), water outlet (2), and gasket (1) from air aftercooler cover (5). Discard gasket (1).
2. Remove two screws (11), water inlet (10), and gasket (9) from intake manifold (12). Discard gasket (9).
3. Remove twenty-four screws (6), air aftercooler cover (5), and gasket (7) from intake manifold (12). Discard gasket (7).
4. Remove eight screws (13), washers (14), and air aftercooler element (15) from intake manifold (12).
5. Remove four O-rings (8) from air aftercooler element (15). Discard O-rings (8).

CLEANING AND INSPECTION

1. For general parts cleaning information, refer to CLEANING, WP 0051 00.
2. For general parts inspection information, refer to INSPECTION, WP 0051 00.

NOTE

Replace any part that does not pass visual inspection or is outside specified wear limits.

3. Inspect water outlet (2), water inlet (10), air aftercooler cover (5), and intake manifold (12) for cracks, corrosion, and stripped or elongated threaded holes. Repair any damaged threaded holes.
4. Inspect air aftercooler element (15) for cracks, corrosion, and stripped or elongated threaded holes. Repair any damaged threaded holes.
5. Inspect air aftercooler element (15) for leaks, as follows:
 - a. Cap one end of air aftercooler element (15) airtight.
 - b. Connect a suitable air pressure tester to other end of air aftercooler element (15).
 - c. Immerse air aftercooler element (15) in tank of water, pressurize air aftercooler element (15) to 20 psi (138 kPA) for 2 minutes, and look for bubbles.
 - d. If a leak is detected, replace air aftercooler element (15).

AIR AFTERCOOLER (Contd)

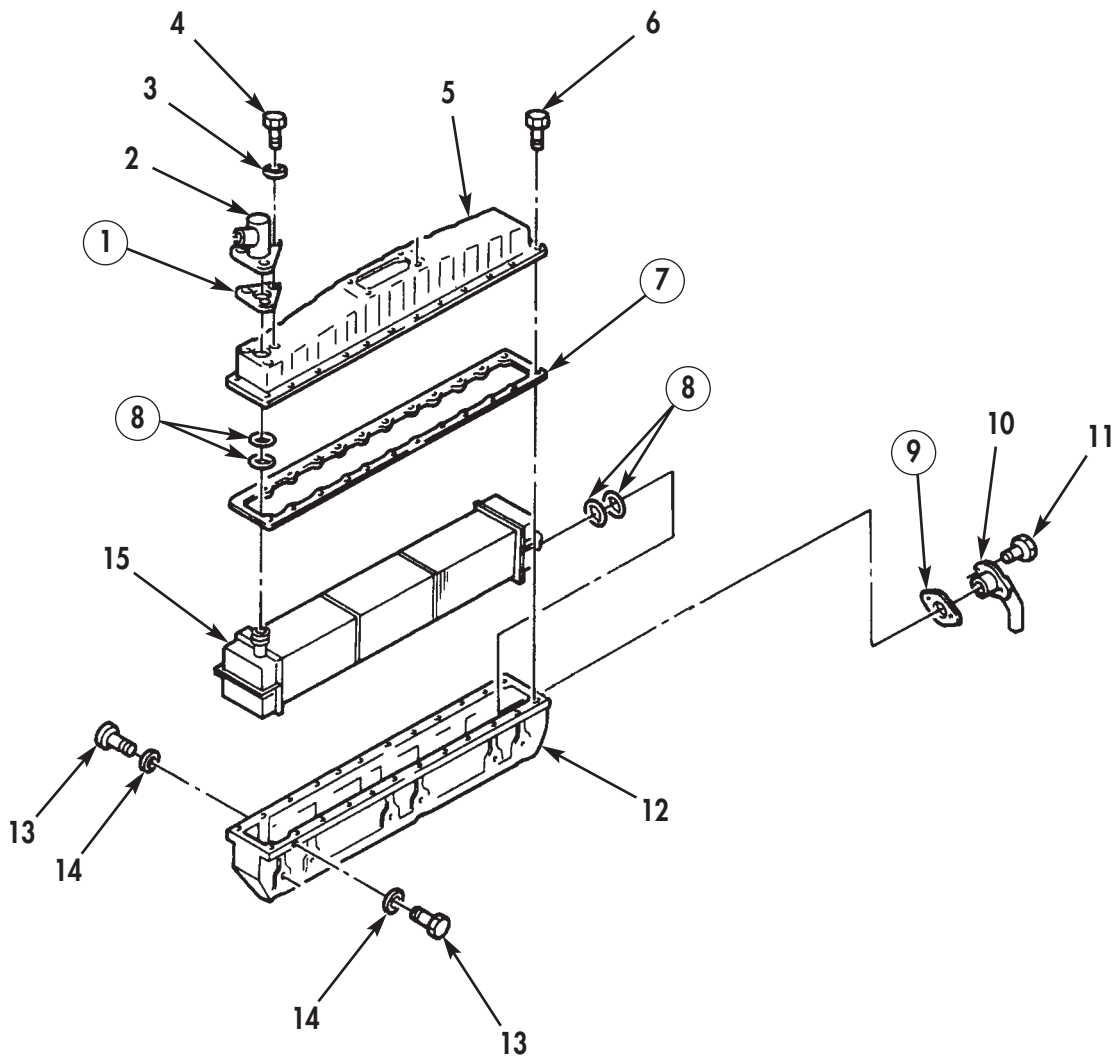


Figure 1. Air Aftercooler Disassembly.

AIR AFTERCOOLER (Contd)

ASSEMBLY

1. Apply OE/HDO 10 lubricating oil to four new O-rings (8) and install O-rings on air aftercooler element (15).

NOTE

Air aftercooler element has a precision fit in intake manifold.
Move air aftercooler element carefully during installation.

2. Install air aftercooler element (15) in intake manifold (12).
3. Hold air aftercooler element (15) to one side of intake manifold (12). Using feeler gauge, measure clearance between air aftercooler element (15) and intake manifold (12). Clearance must be 0.003–0.013in. (0.076–0.330 mm).
4. Align holes in intake manifold (12) with holes in air aftercooler element (15). Install air aftercooler element (15) in intake manifold (12) with eight washers (14) and screws (13). Tighten air aftercooler element screws (13) in sequence 15 lb-ft (20 N•m).
5. Tighten air aftercooler element screws (13) in sequence again 25 lb-ft (34 N•m).
6. Install new gasket (7) and air aftercooler cover (5) on intake manifold (12) with twenty-four screws (6). Do not tighten screws (6) at this time.
7. Install new gasket (9) and water inlet (10) on intake manifold (12) with two screws (11). Tighten screws (11) 32 lb-ft (43 N•m).

NOTE

Big Cam III may be equipped with lockwashers. Replace lockwashers during water outlet installation.

8. Install new gasket (1) and water outlet (2) on air aftercooler cover (5) with three washers (3) and screws (4). Do not tighten screws (4) at this time.
9. Tighten twenty-four screws (6) securing air aftercooler cover (5) to intake manifold (12) in sequence shown 25 lb-ft (34 N•m).
10. Tighten three screws (4) securing water outlet (2) to air aftercooler cover (5) 20 lb-ft (27 N•m).
11. For air aftercooler installation, refer to WP 0045 00.

AIR AFTERCOOLER (Contd)

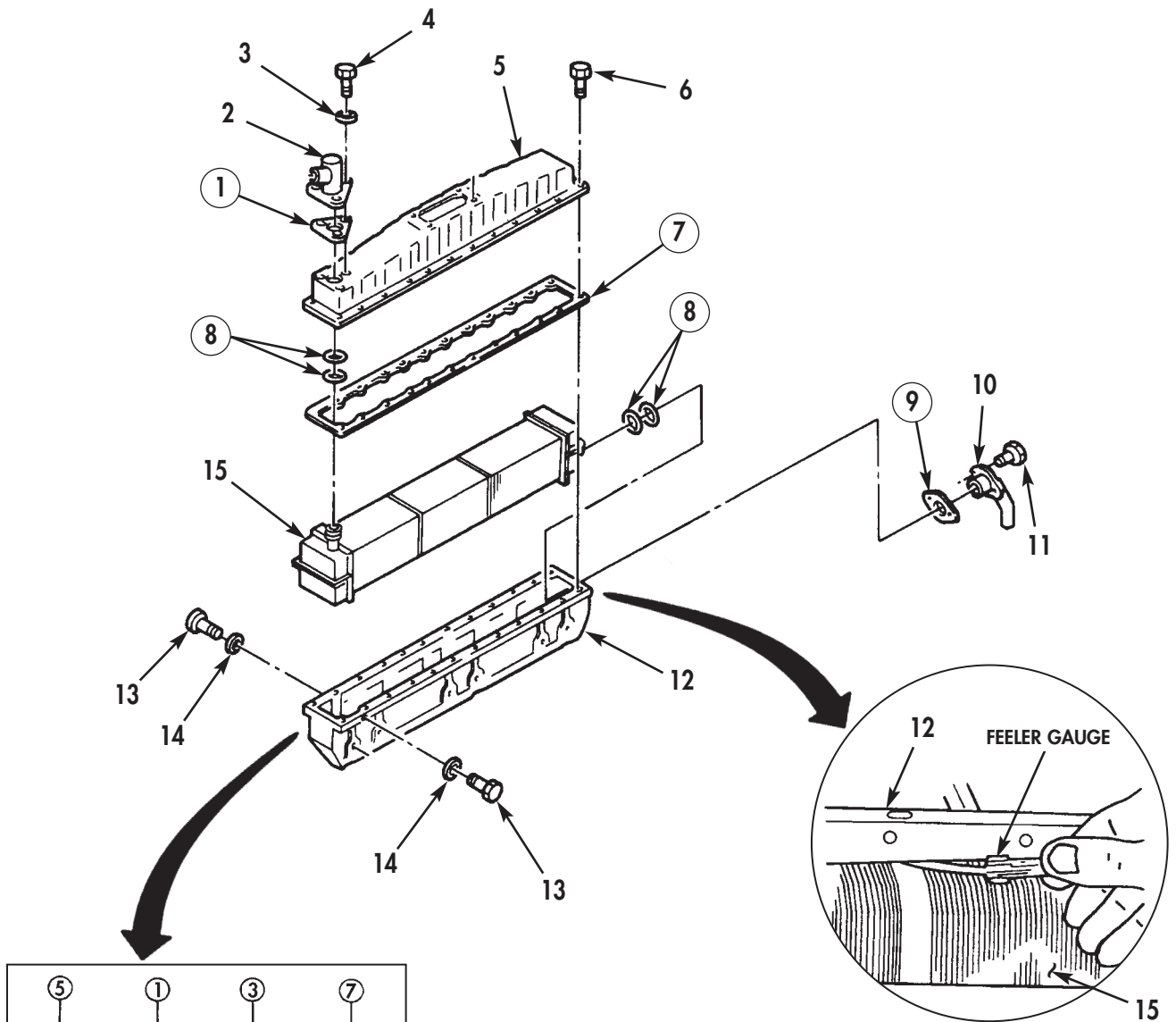


Figure 2. Air Aftercooler Assembly.

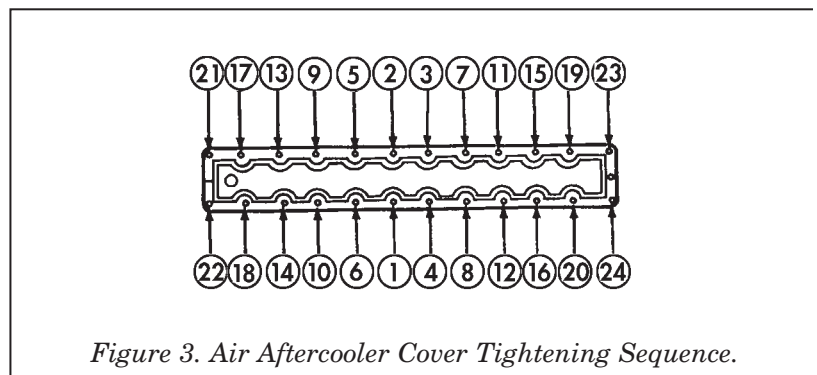
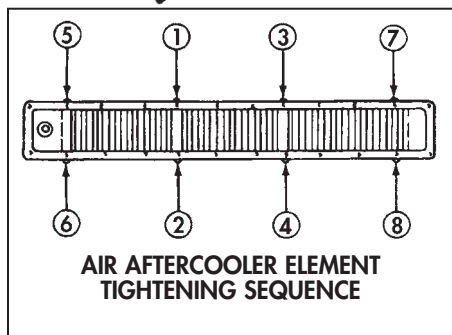


Figure 3. Air Aftercooler Cover Tightening Sequence.

END OF WORK PACKAGE

**DIRECT SUPPORT AND GENERAL SUPPORT
MAINTENANCE MANUAL
INCLUDING REPAIR PARTS AND SPECIAL TOOLS LIST (RPSTL)**

FOR

M915, M915A1, M915A4, M916, M920 VEHICLES

NSN 2815-01-082-8125	P/N NTC400-3652-02	CUMMINS NTC-400 BIG CAM I DIESEL ENGINE W/CONTAINER
NSN 2815-01-142-2745	P/N 11669835	CUMMINS NTC-400 BIG CAM III DIESEL ENGINE W/CONTAINER

EXHAUST MANIFOLD

DISASSEMBLY, CLEANING AND INSPECTION, ASSEMBLY

INITIAL SETUP:

Tools and Special Tools

General mechanic's tool kit:

automotive (Item 1, WP 0061 00)

Maintenance and repair shop equipment:

automotive (Item 2, WP 0061 00)

Automotive maintenance and repair

supplemental set no. 2 (Item 3, WP 0061 00)

Materials/Parts

Antiseize compound (Item 7, WP 0060 00)

Pipe sealant (Item 25, WP 0060 00)

Two spacer inserts

(Item 1, Table 9, WP 0062 00)

Equipment Condition

Exhaust manifold removed from engine

(WP 0009 00).

EXHAUST MANIFOLD (Contd)

DISASSEMBLY

NOTE

Big Cam I engines utilize a conventional log-type exhaust manifold. Big Cam III engines utilize a pulse-type exhaust manifold and a new design exhaust manifold with 2 spacer inserts. Disassembly and assembly of exhaust manifolds are basically alike for both engines.

Exhaust manifold parts are fitted together tightly and may require extreme force to separate.

Perform steps 1 through 3 for Big Cam I.

1. Remove front exhaust manifold (1) and rear exhaust manifold (4) from center exhaust manifold (2).
2. Remove two pipe plugs (3) from center exhaust manifold (2).
3. Remove four turbocharger mounting studs (5) from center exhaust manifold (2).

NOTE

Perform steps 4 and 5 for Big Cam III.

4. Remove front exhaust manifold (6) and rear exhaust manifold (9) from center exhaust manifold (7).
5. Remove four turbocharger mounting studs (8) from center exhaust manifold (7).

NOTE

Perform steps 6 through 8 for Big Cam III new design.

6. Remove front exhaust manifold (10) and rear exhaust manifold (14) from spacer inserts (11).
7. Remove two spacer inserts (11) from center exhaust manifold (12). Discard spacer inserts (11).
8. Remove four turbocharger mounting studs (13) from center exhaust manifold (12).

CLEANING AND INSPECTION

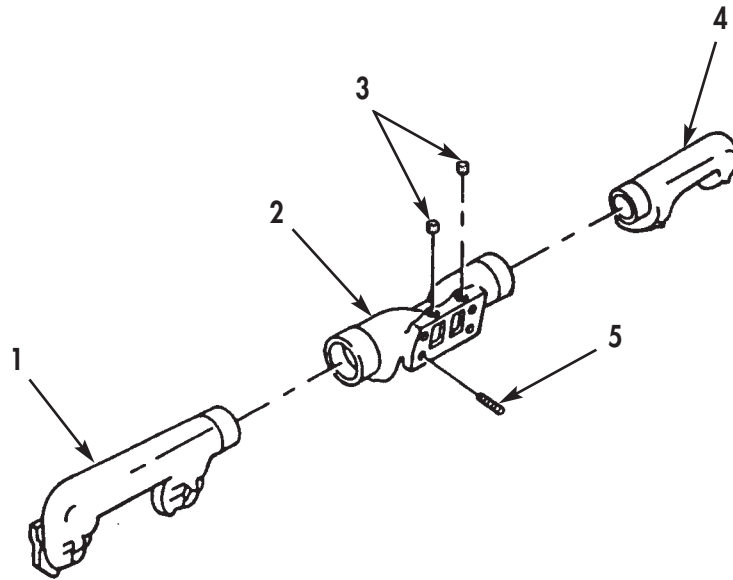
1. For general parts cleaning information, refer to CLEANING, WP 0051 00.
2. For general parts inspection information, refer to INSPECTION, WP 0051 00.

NOTE

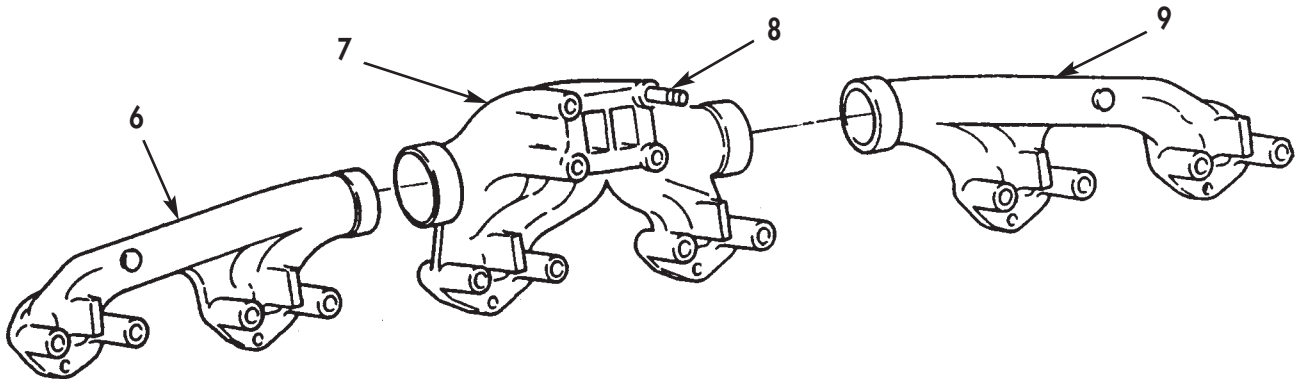
Replace any part that does not pass visual inspection or is outside specified wear limits.

3. Inspect front exhaust manifold (1), (6), and (10), center exhaust manifold (2), (7), and (12), and rear exhaust manifold (4), (9), and (14) for cracks, distortion, and corrosion.
4. Inspect turbocharger mounting studs (5), (8), and (13) for stripped threads. Repair all damaged threads.
5. Inspect center exhaust manifold (2), (7), and (12) for stripped threads or damaged holes. Repair all damaged threads and holes.

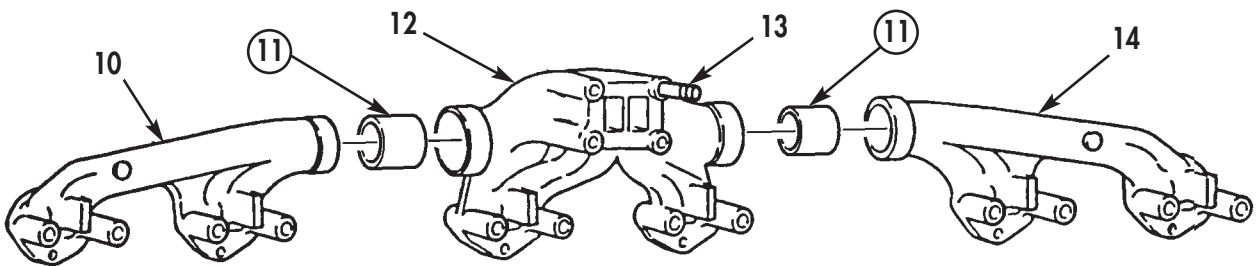
EXHAUST MANIFOLD (Contd)



BIG CAM I



BIG CAM III



BIG CAM III - NEW DESIGN

Figure 1. Exhaust Manifold Disassembly.

EXHAUST MANIFOLD (Contd)

ASSEMBLY

NOTE

Perform steps 1 through 4 for Big Cam III new design.

1. Install four turbocharger mounting studs (4) in center exhaust manifold (3).
2. Install two new spacer inserts (2) in center exhaust manifold (3).
3. Apply antiseize compound to mating surfaces of front exhaust manifold (1), spacer inserts (2), and rear exhaust manifold (5).
4. Install front exhaust manifold (1) and rear exhaust manifold (5) on spacer inserts (2).

NOTE

Perform steps 5 through 7 for Big Cam III.

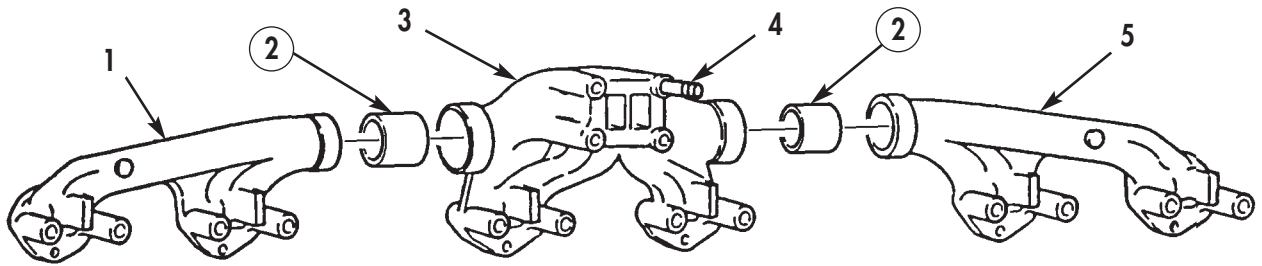
5. Install four turbocharger mounting studs (8) in center exhaust manifold (7).
6. Apply antiseize compound to mating surfaces of front exhaust manifold (6), center exhaust manifold (7), and rear exhaust manifold (9).
7. Install front exhaust manifold (6) and rear exhaust manifold (9) on center exhaust manifold (7).

NOTE

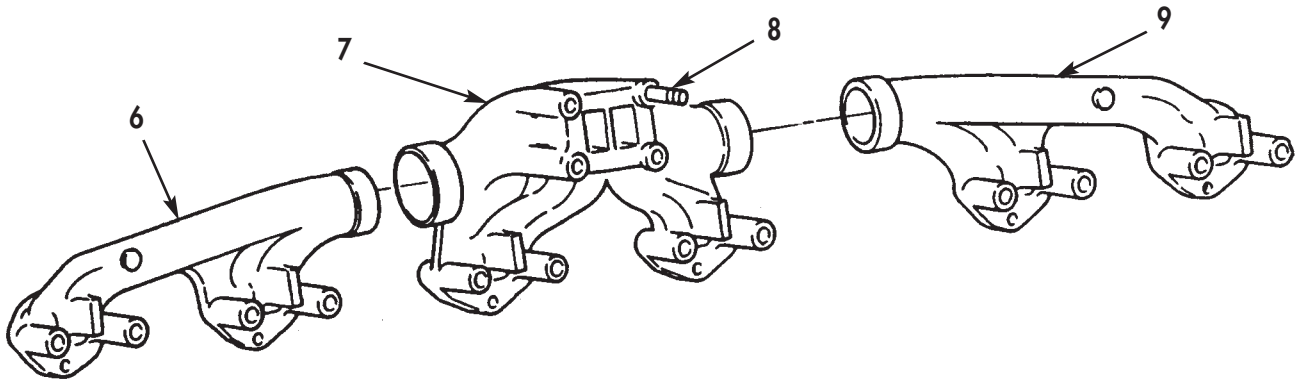
Perform steps 8 through 11 for Big Cam I.

8. Install 4 turbocharger mounting studs (14) in center exhaust manifold (11).
9. Apply pipe sealant on 2 pipe plugs (12) and install pipe plugs (12) in center exhaust manifold (11).
10. Apply antiseize compound to mating surfaces of front exhaust manifold (10), center exhaust manifold (11), and rear exhaust manifold (13).
11. Install front exhaust manifold (10) and rear exhaust manifold (13) on center exhaust manifold (11).
12. Install exhaust manifold on engine (WP 0046 00).

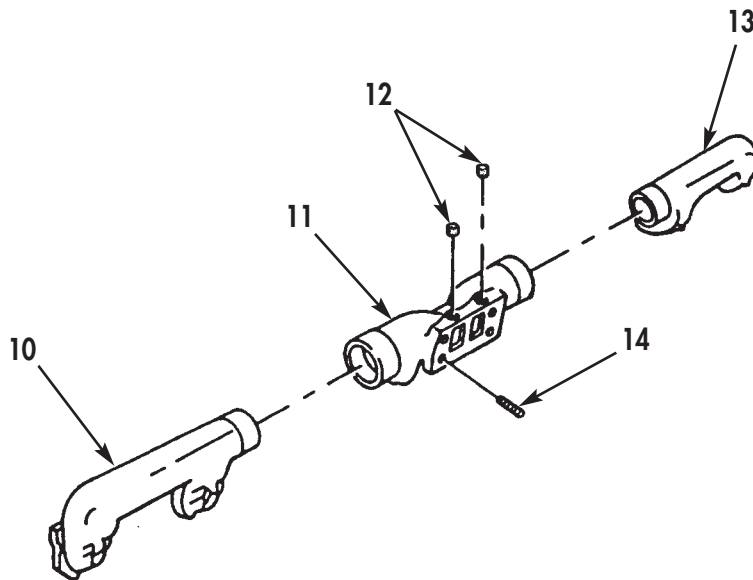
EXHAUST MANIFOLD (Contd)



BIG CAM III - NEW DESIGN



BIG CAM III



BIG CAM I

Figure 2. Exhaust Manifold Assembly.

END OF WORK PACKAGE

**DIRECT SUPPORT AND GENERAL SUPPORT
MAINTENANCE MANUAL
INCLUDING REPAIR PARTS AND SPECIAL TOOLS LIST (RPSTL)**

FOR

M915, M915A1, M915A4, M916, M920 VEHICLES

NSN 2815-01-082-8125	P/N NTC400-3652-02	CUMMINS NTC-400 BIG CAM I DIESEL ENGINE W/CONTAINER
NSN 2815-01-142-2745	P/N 11669835	CUMMINS NTC-400 BIG CAM III DIESEL ENGINE W/CONTAINER

TURBOCHARGER

DISASSEMBLY, CLEANING AND INSPECTION, ASSEMBLY

INITIAL SETUP:

Tools and Special Tools

General mechanic's tool kit: automotive
(Item 1, WP 0061 00)
Maintenance and repair shop equipment:
automotive (Item 2, WP 0061 00)
Automotive maintenance and repair
supplemental set no. 2 (Item 3, WP 0061 00)
Press

Equipment Condition

Turbocharger removed from engine
(WP 0009 00).

Materials/Parts

Crocus cloth (Item 4, WP 0060 00)
Antiseize compound (Item 7, WP 0060 00)
OE/HDO 30 lubricating oil
(Item 20, WP 0060 00)
Locknut (Item 3, Table 10, WP 0062 00)
Sleeve (Item 1, Table 10, WP 0062 00)
Ring seal (Item 2, Table 10, WP 0062 00)
Bearing insert pad
(Item 3, Table 10, WP 0062 00)
Impeller locknut
(Item 4, Table 10, WP 0062 00)
Screw (Item 5, Table 10, WP 0062 00)
Diffuser plate (Item 6, Table 10, WP 0062 00)
O-ring (Item 7, Table 10, WP 0062 00)
Bearing (Item 9, Table 10, WP 0062 00)
Insulated packing
(Item 10, Table 10, WP 0062 00)
Two ring seals (Item 11, Table 10, WP 0062 00)

TURBOCHARGER (Contd)

DISASSEMBLY

1. For removal of turbocharger, refer to WP 0010 00.
2. Scribe locating mark (2) on impeller housing (1), bearing housing (4), and turbine housing (3) before disassembly.
3. Remove two adapters (12) and (19) from bearing housing (4).
4. Remove two locknuts (8), screws (11), four washers (7) and (10), and V-band clamp (9) from impeller housing (1), bearing housing (4), and turbine housing (3). Discard locknuts (8) and screws (11).
5. Remove impeller housing (1) from bearing housing (4).
6. Remove turbine housing (3) from bearing housing (4).
7. Remove impeller locknut (6) from wheel and shaft assembly (23). Discard locknut (6).
8. Using press, remove wheel and shaft assembly (23) and turbocharger impeller (5) from bearing housing (4).
9. Remove heat shield (21) and insulated packing (20) from bearing housing (4). Discard insulated packing (20).
10. Remove diffuser plate (15), bearing insert pad (17), and bearing (18) from bearing housing (4). Discard bearing insert pad (17), bearing (18) and diffuser plate (15) which includes sleeve (13), ring seal (14) and O-ring (16).
11. Remove two ring seals (22) from wheel and shaft assembly (23). Discard ring seals (22).

CLEANING AND INSPECTION

1. For general parts cleaning information, refer to CLEANING, WP 0051 00.
2. For general parts inspection information, refer to INSPECTION, WP 0051 00.

NOTE

Replace any part that does not pass visual inspection or is outside specified wear limits.

3. Inspect impeller housing (1) and turbine housing (3) for cracks, chips, and scratches. Remove small scratches and chips from machined surfaces with crocus cloth.
4. Inspect diffuser plate (15) for cracks or damage at bearing insert pad (17), contact point.
5. Inspect heat shield (21) for cracks and chips.
6. Using a straightedge, inspect heat shield (21) for straightness. Discard heat shield (21) if warped.

TURBOCHARGER (Contd)

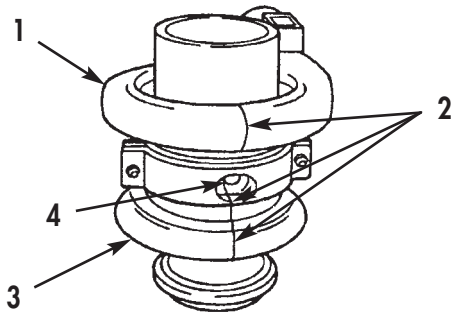


Figure 1. Locating Marks.

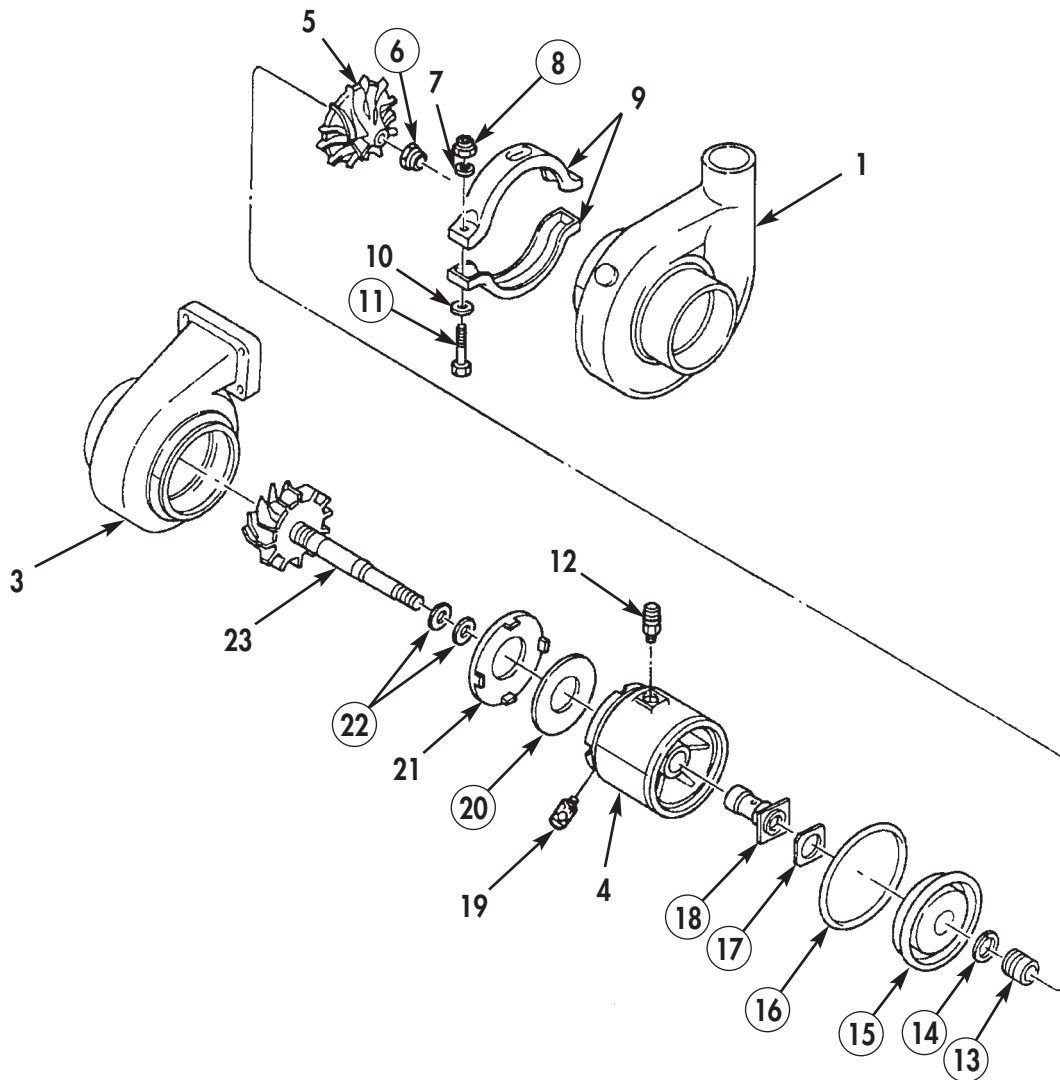


Figure 2. Turbocharger Disassembly.

TURBOCHARGER (Contd)

CLEANING AND INSPECTION (Contd)

7. Inspect turbocharger impeller blades (1) for cracks and chips.
8. Inspect bearing housing (2) for cracks, chips, and scratches. Remove small scratches and chips from machined surfaces with crocus cloth.
9. Measure bearing housing (2) from compressor housing stop to turbine housing stop at four equal locations. Minimum length is 2.986 in. (7.584 cm). Replace bearing housing (2) if distorted.
10. Inspect turbine blades (3) for cracks and chips.
11. Inspect wheel and shaft seal ring grooves (6) for small grooves, chips, or cracks. Remove small grooves with crocus cloth.
12. Inspect wheel and shaft weld area (4) for chips, scratches, or cracks. Replace wheel and shaft (5) if three or more cracks are found, or if cracks exceed 0.375 in. (9.525 mm) in length, have a minimum distance of 0.250 in. (6.35 mm), or exceed 0.0625 in. (1.587 mm) in length on welded area (4) circumference.
13. Using dial indicator, measure wheel and shaft (5) runout 1 in. (25.4 mm) from bearing surface of wheel and shaft (5). Wheel and shaft (5) maximum runout is 0.00005 in. (0.0127 mm). Discard wheel and shaft (5), if runout is exceeded.

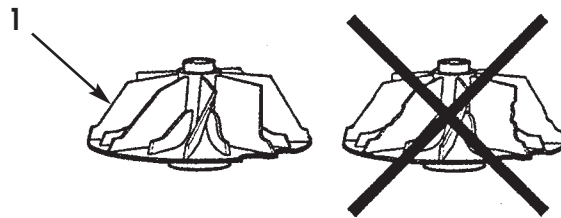


Figure 3. Impeller Blade Inspection.

TURBOCHARGER (Contd)

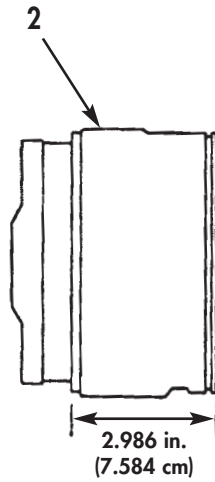


Figure 4. Bearing Housing Measurement.

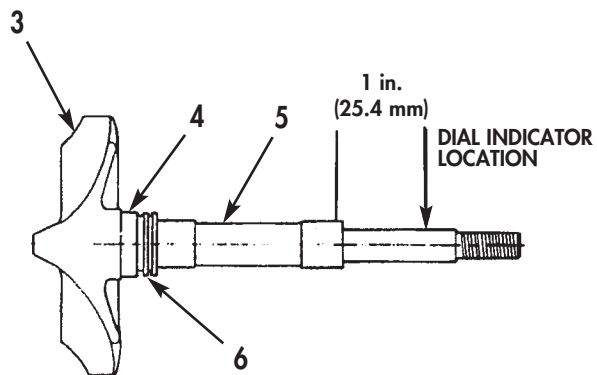


Figure 5. Wheel and Shaft Inspection.

TURBOCHARGER (Contd)

ASSEMBLY

1. Apply OE/HDO 30 lubricating oil to new bearing (16) and install in bearing housing (17).
2. Bend edges of new bearing insert pad (15) over bearing housing (17). Apply OE/HDO 30 lubricating oil to bearing insert pad (15) and install on bearing (16).
3. Apply OE/HDO 30 lubricating oil to new ring seal (12) and install on new sleeve (11).
4. Install new sleeve (11) and ring seal (12), with spiral grooves facing bearing, in new diffuser plate (13) until sleeve is flush with turbocharger impeller (1) end.
5. Apply OE/HDO 30 lubricating oil to new O-ring (14) and install on diffuser plate (13).

CAUTION

Do not rotate diffuser plate after assembly. Any rotation will displace and damage bearing insert pad.

NOTE

Ensure bearing insert pad is centered during diffuser plate installation.

6. Install diffuser plate (13) on bearing housing (17).
7. Position new insulated packing (19) on bearing housing (17), with flat side of insulated packing (19) facing out.
8. Align heat shield (20) locating tabs with depressions in bearing housing (17) and install heat shield (20) on bearing housing (17).

NOTE

New seals must be expanded slightly before installation. Do not overexpand seals or an improper fit on wheel and shaft may occur.

9. Install two new seals (21) on wheel and shaft (22). Rotate seal gaps 90° apart.

WARNING

Turbine wheel machined edges are very sharp. Wear protective gloves when handling turbine wheel. Failure to do so may result in injury to personnel.

10. Install wheel and shaft (22) in bearing housing (17). Ensure heat shield (20) and sleeve (11) remain in position.
11. Using press, install turbocharger impeller (1) on wheel and shaft (22).
12. Install new impeller locknut (2) on wheel and shaft (22). Tighten locknut (2) 20–24 lb-ft (27–32 N•m).
13. Apply antiseize compound to turbine housing (23). Align mark (7) made on turbine housing (23) to mark (7) on bearing housing (17). Install turbine housing (23) on bearing housing (17).
14. Apply antiseize compound on impeller housing (6). Align mark (7) made on impeller housing (6) to mark (7) on bearing housing (17). Install impeller housing (6) on bearing housing (17).
15. Install V-band clamp (5) on impeller housing (6), bearing housing (17), and turbine housing (23) with two new screws (9), four washers (3) and (8), and two new locknuts (4). Tighten locknuts (4) 58–68 lb-in. (6.6–7.7 N•m).
16. Apply antiseize compound to two adapters (10) and (18) and install on bearing housing (17). Tighten adapter (10) 20–25 lb-ft (27–34 N•m). Tighten adapter (18) 50 lb-ft (68 N•m).
17. Using feeler gauge, measure clearance between turbine housing (23) and V-band clamp (5). Minimum clearance is 0.035 in. (0.889 mm). Loosen V-band clamp (5) and adjust turbine housing (23) as necessary to obtain correct clearance.
18. Using feeler gauge, measure clearance between impeller (1) and inside of impeller housing (6). Minimum clearance is 0.006–0.025 in. (0.152–0.635 mm). Loosen V-band clamp (5) and adjust impeller housing (6) as necessary to obtain correct clearance.

TURBOCHARGER (Contd)**ASSEMBLY (Contd)**

19. Using feeler gauge, measure clearance between wheel and shaft (22) and turbine housing (23). Minimum clearance is 0.005–0.043 in. (0.127–0.092 mm). Loosen V-band clamp (5) and turbine housing (23) as necessary to obtain correct clearance.
20. Using dial indicator, measure wheel and shaft (22) end play. Wheel and shaft (22) end play must be within 0.006–0.0018 in. (0.152–0.457 mm). Loosen and retighten impeller locknut (2) until correct endplay is obtained.
21. For installation of turbocharger, refer to WP 0046 00.

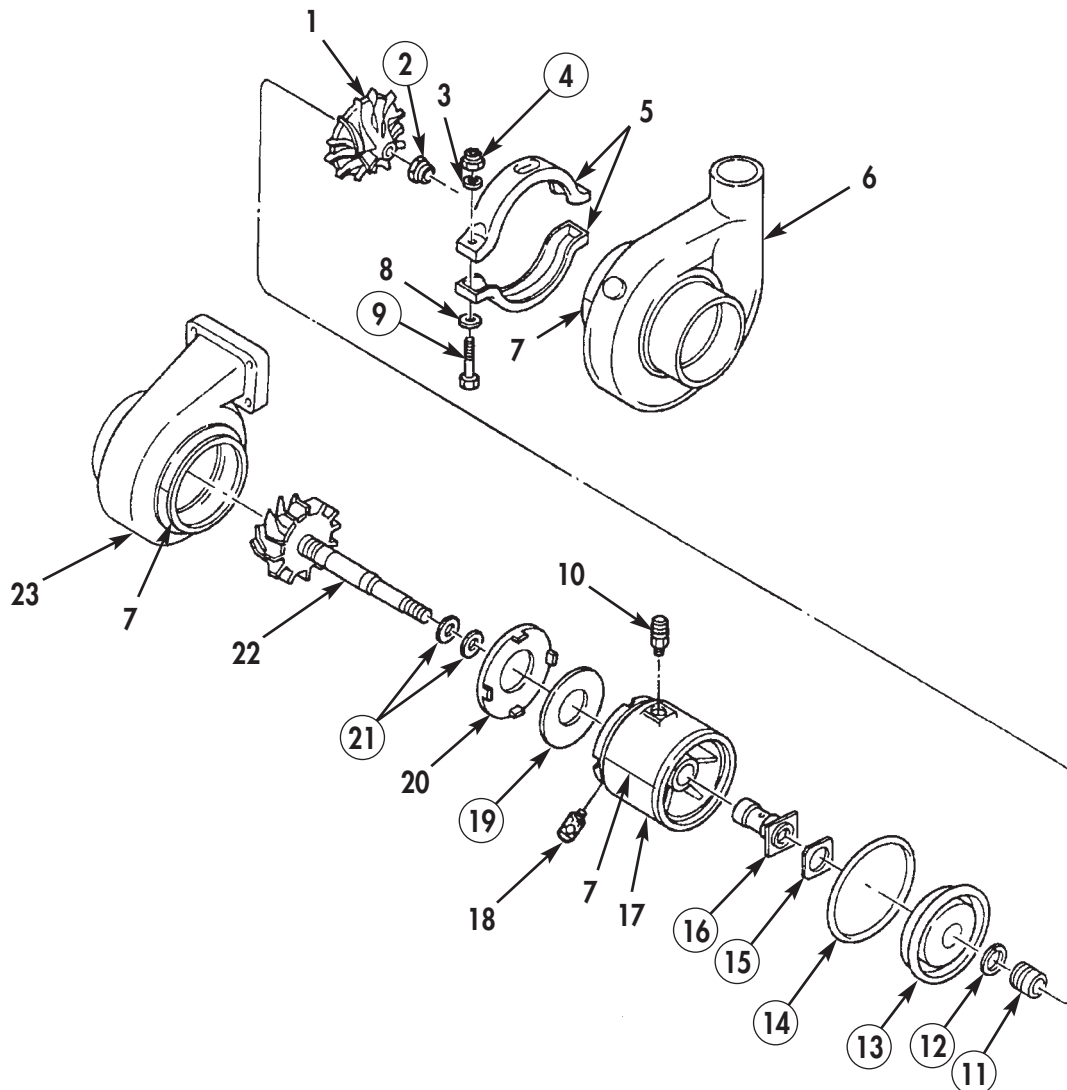


Figure 6. Turbocharger Assembly.

END OF WORK PACKAGE

0026 00-7/8 blank

**DIRECT SUPPORT AND GENERAL SUPPORT
MAINTENANCE MANUAL
INCLUDING REPAIR PARTS AND SPECIAL TOOLS LIST (RPSTL)**

FOR

M915, M915A1, M915A4, M916, M920 VEHICLES

NSN 2815-01-082-8125	P/N NTC400-3652-02	CUMMINS NTC-400 BIG CAM I DIESEL ENGINE W/CONTAINER
NSN 2815-01-142-2745	P/N 11669835	CUMMINS NTC-400 BIG CAM III DIESEL ENGINE W/CONTAINER

TURBOCHARGER HT-3B

DISASSEMBLY, CLEANING AND INSPECTION, ASSEMBLY

INITIAL SETUP:

Tools and Special Tools

General mechanic's tool kit:
 automotive (Item 1, WP 0061 00)
 Maintenance and repair shop equipment:
 automotive (Item 2, WP 0061 00)
 Automotive maintenance and repair
 supplemental set no. 2 (Item 3, WP 0061 00)
 Turbocharger mounting plate
 (Item 19, WP 0061 00)
 Ball joint vise (Item 9, WP 0061 00)

Materials/Parts

Four retaining rings
 (Item 1, Table 11, WP 0062 00)
 Two seal rings (Item 2, Table 11, WP 0062 00)
 Seal (Item 3, Table 11, WP 0062 00)
 Two sleeve bearings
 (Item 4, Table 11, WP 0062 00)
 Thrust collar (Item 5, Table 11, WP 0062 00)
 Locknut (Item 6, Table 11, WP 0062 00)
 Ten lockwashers
 (Item 7, Table 11, WP 0062 00)
 Retaining ring (Item 8, Table 11, WP 0062 00)
 Oil seal plate (Item 9, Table 11, WP 0062 00)
 Oil slinger (Item 10, Table 11, WP 0062 00)
 O-ring (Item 11, Table 11, WP 0062 00)
 Oil baffle (Item 12, Table 11, WP 0062 00)
 Thrust bearing
 (Item 13, Table 11, WP 0062 00)
 Seal ring (Item 14, Table 11, WP 0062 00)

Materials/Parts (Contd)

Sleeve bushing
 (Item 15, Table 11, WP 0062 00)
 Lubricating oil OE/HDO 10
 (Item 19, WP 0060 00)
 Antiseize compound (Item 7, WP 0060 00)
 Crocus cloth (Item 4, WP 0060 00)

Equipment Condition

Turbocharger HT-3B removed from engine
 (WP 0009 00).

TURBOCHARGER HT-3B (Contd)

DISASSEMBLY

1. Install turbocharger HT-3B assembly (1) on turbocharger mounting plate and ball joint vise with two bolts (2).
2. Scribe a locating mark (6) on impeller housing (3), bearing housing (4), and turbine housing (5) to aid in assembly.

CAUTION

Use care when removing impeller housing from bearing housing. Impeller blades can be easily damaged.

3. Remove ten screws (20), lockwashers (21), two clamping plates (22), and impeller housing (3) from bearing housing (4). Discard lockwashers (21).

CAUTION

Use care when removing turbine housing from bearing housing. Turbine blades can be easily damaged.

4. Remove nut (15), V-band clamp (14), and turbine housing (5) from bearing housing (4).
5. Remove locknut (23) and impeller (24) from wheel and shaft (7). Discard locknut (23).
6. Remove wheel and shaft (7) from bearing housing (4).
7. Remove two seal rings (8) from wheel and shaft (7). Discard seal rings (8).
8. Remove retaining ring (25) and oil seal plate (26) from bearing housing (4). Discard retaining ring (25).
9. Remove O-ring (29) from oil seal plate (26). Discard O-ring (29) and oil seal plate (26).
10. Remove oil slinger (28) and seal ring (27) from bearing housing (4). Discard oil slinger (28) and seal ring (27).
11. Remove oil baffle (30), thrust bearing (31), thrust collar (19), and two dowel pins (16) from bearing housing (4). Discard oil baffle (30), thrust bearing (31), and thrust collar (19).
12. Remove two retaining rings (17) and sleeve bearing (18) from bearing housing (4). Discard sleeve bearings (18) and retaining rings (17).
13. Remove seal (9) and heat shield (10) from bearing housing (4). Discard seal (9).
14. Remove two retaining rings (11), sleeve bushing (12), and sleeve bearing (13) from bearing housing (4). Discard sleeve bushing (12), sleeve bearing (13), and retaining rings (11).

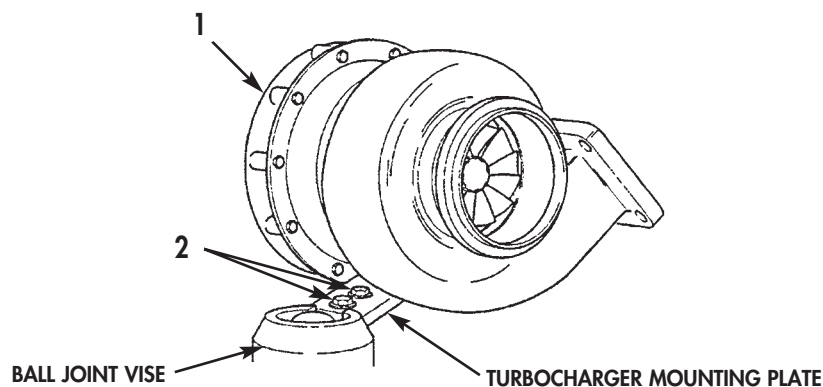


Figure 1. Mounting Turbocharger on Stand.

TURBOCHARGER HT-3B (Contd)

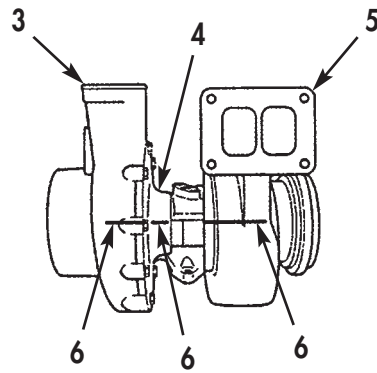


Figure 2. Turbocharger HT-3B Locating Marks.

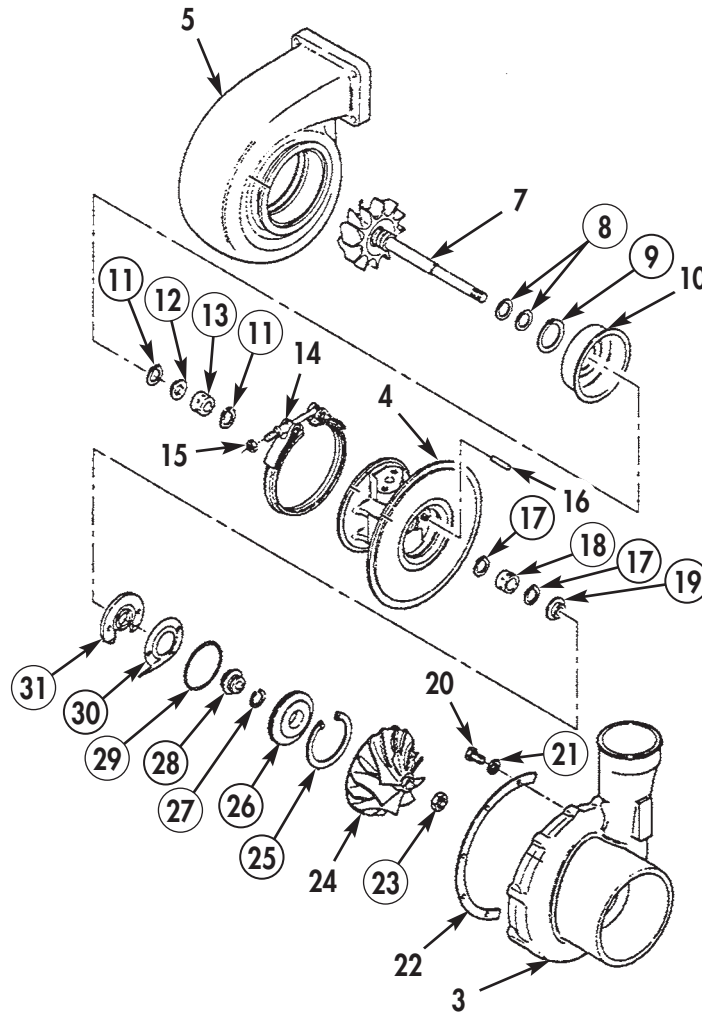


Figure 3. Turbocharger HT-3B Disassembly.

TURBOCHARGER HT-3B (Contd)

CLEANING AND INSPECTION

1. For general parts cleaning information, refer to CLEANING, WP 0051 00.
2. For general parts inspection information, refer to INSPECTION, WP 0051 00.

NOTE

Replace any part that does not pass visual inspection or is outside specified wear limits.

3. Inspect impeller housing (5) and turbine housing (1) for cracks, chips, and scratches. Use crocus cloth to remove small scratches and chips from machined surfaces.
4. Inspect impeller (6) and wheel and shaft (2) vanes for cracks and chips.
5. Inspect two dowel pins (4) for cracks, chips, and bends.
6. Inspect V-band clamp (11) for cracks, chips, bends, or separation.
7. Inspect heat shield (3) for cracks and chips.
8. Using a straightedge, inspect heat shield (3) for straightness and warpage. Discard heat shield (3) if warped.
9. Inspect oil seal plate (7) for cracks, chips or galled bore.
10. Inspect bearing housing (10) for cracks, chips, and scratches.
11. Inspect bearing housing (10) for notches in dome area. Discard if notches are found.
12. Using inside micrometer, measure bearing housing (10) bore inside diameter. Replace bearing housing (10) if inside diameter is more than 0.876 in. (22.268 mm).
13. Using feeler gauge, insert outside edge of feeler gauge and new seal ring (13) in wheel and shaft (2) seal ring grooves. Replace wheel and shaft (2) if seal ring clearance is more than 0.0005 in. (0.13 mm).
14. Using micrometer, measure wheel and shaft (2) bearing area outside diameter. Replace wheel and shaft (2) if bearing area outside diameter is less than 0.5611 in. (14.252 mm).
15. Using micrometer, measure thrust collar (9) thickness. Replace thrust collar (9) if thickness is less than 0.0980 in. (2.489 mm).
16. Using feeler gauge, insert outside edge of feeler gauge and new seal ring (12) in oil slinger (8) seal ring groove. Replace oil slinger (8) if seal ring clearance is more than 0.0005 in. (0.13 mm).

TURBOCHARGER HT-3B (Contd)

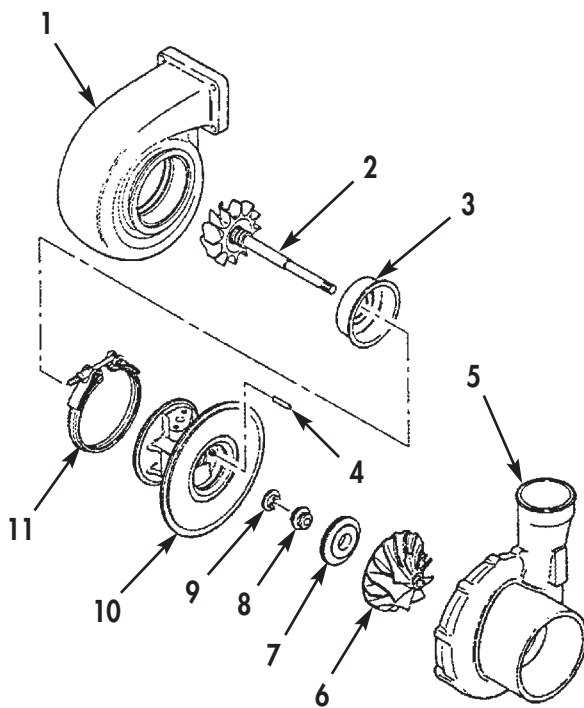


Figure 4. Turbocharger HT-3B Inspection.

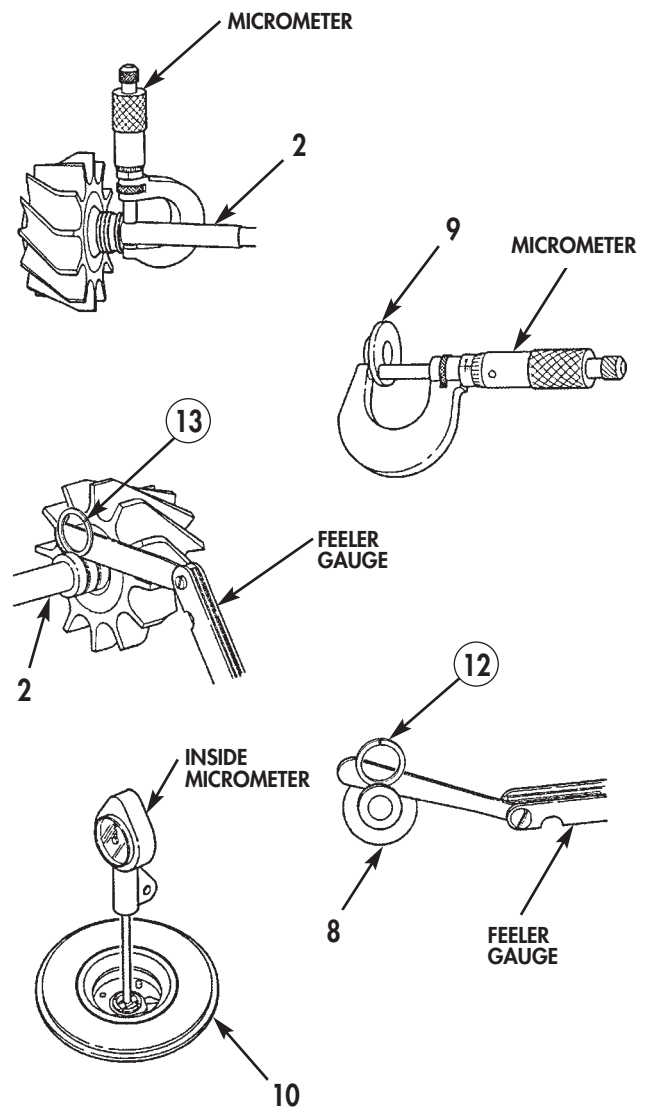


Figure 5. Turbocharger HT-3B Measurements.

TURBOCHARGER HT-3B (Contd)

ASSEMBLY

CAUTION

Retaining rings must be installed with beveled edge facing bearing. Excessive bearing wear can result if retaining rings are installed incorrectly.

NOTE

Apply lubricating oil to all internal parts before assembly.

1. Install two new retaining rings (7), new sleeve bearing (9), and new sleeve bushing (8) in bearing housing (11).
2. Install heat shield (6) and new seal ring (5) in bearing housing (11).
3. Install two new retaining rings (13) and new sleeve bearing (14) in bearing housing (11).
4. Install two dowel pins (12), new thrust collar (15), and new thrust bearing (28) in bearing housing (11).
5. Position new oil baffle (27) in bearing housing (11).
6. Install new seal ring (24) on new oil slinger (25), and install new O-ring (26) on new oil seal plate (23).
7. Install oil slinger (25), oil seal plate (23), and new retaining ring (22) in bearing housing (11).
8. Install two new seal rings (4) on wheel and shaft (3).
9. Install wheel and shaft (3) in bearing housing (11) heat shield (6) side.
10. Install impeller (21) and new locknut (20) on wheel and shaft (3). Tighten locknut (20) 30 lb-ft (41 N•m).
11. Apply antiseize compound to threads on V-band clamp (10) and to mating surfaces of turbine housing (1) and bearing housing (11).
12. Position V-band clamp (10) on bearing housing (11).

CAUTION

Use care when installing turbine housing on bearing housing.
Turbine blades can be easily damaged.

13. Align scribe mark (2) on turbine housing (1) with scribe mark (2) on bearing housing (11). Install turbine housing (1) on bearing housing (11) with V-band clamp (10) and nut (29). Tighten nut (29) 10 lb-ft (13.6 N•m).

CAUTION

Use care when installing impeller housing on bearing housing.
impeller blades can be easily damaged.

14. Align scribe mark (2) on impeller housing (18) with scribe mark (2) on bearing housing (11). Install impeller housing (18) on bearing housing (11) with two clamping plates (19), ten new lockwashers (17), and screws (16). Tighten screws (16) 5 lb-ft (6.8 N•m).

NOTE

Turbine blade-to-turbine housing measurement area shown.
Impeller blade-to-impeller housing measurement similar.

15. Using feeler gauge, check turbine blade (30)-to-turbine housing (2) clearance. Minimum clearance allowed is 0.008 in. (0.20 mm).

TURBOCHARGER HT-3B (Contd)

ASSEMBLY (Contd)

16. Using feeler gauge, check impeller (19)-to-impeller housing (18) clearance. Minimum clearance allowed is 0.006 in. (0.15 mm).
17. Using dial indicator, check wheel and shaft (3) end play. Wheel and shaft (3) end play should be 0.001–0.004 in. (0.254–0.1 mm).
18. Remove two bolts (31), turbocharger mounting plate, and turbocharger HT-3B from ball joint vise.
19. For turbocharger HT-3B installation, refer to WP 0046 00.

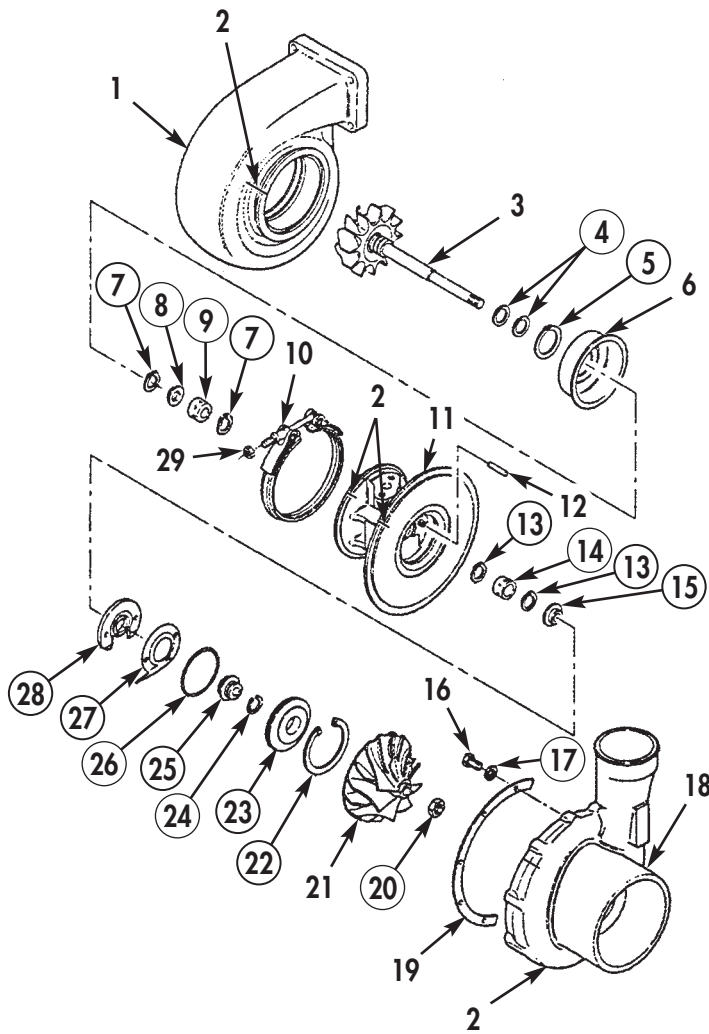


Figure 6. Turbocharger HT-3B Assembly.

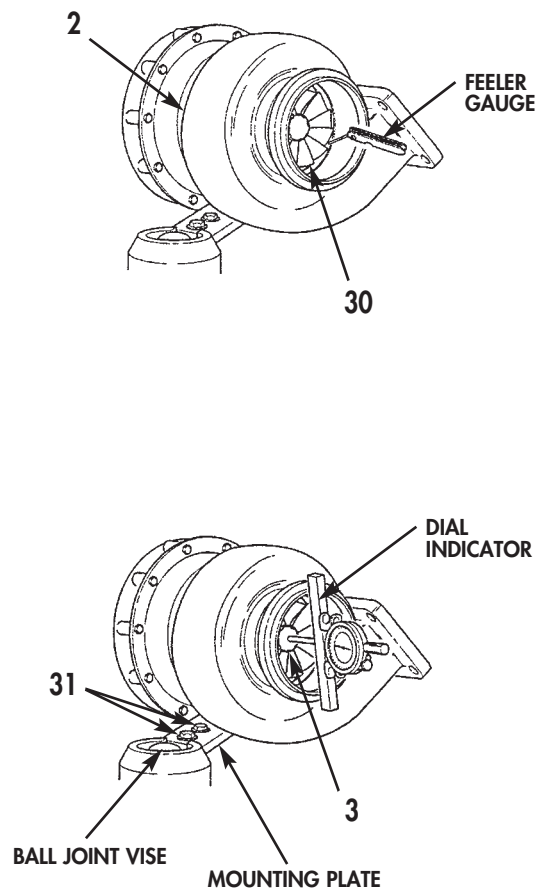


Figure 7. Turbocharger HT-3B Assembly.

**DIRECT SUPPORT AND GENERAL SUPPORT
MAINTENANCE MANUAL
INCLUDING REPAIR PARTS AND SPECIAL TOOLS LIST (RPSTL)**

FOR

M915, M915A1, M915A4, M916, M920 VEHICLES

NSN 2815-01-082-8125	P/N NTC400-3652-02	CUMMINS NTC-400 BIG CAM I DIESEL ENGINE W/CONTAINER
NSN 2815-01-142-2745	P/N 11669835	CUMMINS NTC-400 BIG CAM III DIESEL ENGINE W/CONTAINER

FRONT GEAR COVER

DISASSEMBLY, CLEANING AND INSPECTION, ASSEMBLY

INITIAL SETUP:

Tools and Special Tools

General mechanic's tool kit: automotive
(Item 1, WP 0061 00)
Maintenance and repair shop equipment:
automotive (Item 2, WP 0061 00)
Automotive maintenance and repair
supplemental set no. 2 (Item 3, WP 0061 00)
Puller/installer (Item 33, WP 0061 00)
Mandrel (Item 39, WP 0061 00)
Oil seal expander
(Item 29, WP 0061 00)
Press

Equipment Condition

Front gear cover removed from engine
(WP 0012 00).

Materials/Parts

Pipe sealant (Item 25, WP 0060 00)
Oil seal (Item 1, Table 12, WP 0062 00)
Crankshaft oil seal
(Item 2, Table 12, WP 0062 00)
O-ring (Item 3, Table 12, WP 0062 00)
Sleeve bushing (Item 4, Table 12, WP 0062 00)

FRONT GEAR COVER (Contd)

DISASSEMBLY

1. Using puller/installer, remove accessory drive oil seal (5) from front gear cover (7). Discard oil seal (5).
2. Using puller/installer, remove crankshaft oil seal (9) from front gear cover (7). Discard crankshaft oil seal (9).

NOTE

Do not discard shims. Leave shims in order of removal to aid in assembly.

3. Remove three screws (1), camshaft support (2), and shims (3) from front gear cover (7).
4. Remove O-ring (4) from camshaft support (2). Discard O-ring (4).
5. Remove three threaded plugs (8) from front gear cover (7).
6. Using mandrel and press, remove sleeve bushing (6) from front gear cover (7). Discard sleeve bushing (6).

CLEANING AND INSPECTION

1. For general parts cleaning information, refer to CLEANING, WP 0051 00.
2. For general parts inspection information, refer to INSPECTION, WP 0051 00.

NOTE

Replace any part that does not pass visual inspection or is outside specified wear limits.

3. Using inside micrometer, measure inside diameter of camshaft support (2). Maximum inside diameter is 1.757 in. (4.46 cm).
4. Inspect camshaft support (2) for cracks, scoring, or pitting.
5. Inspect front gear cover (7) for cracks, distortion, stripped or elongated bolt holes, or stripped holes. Repair any stripped holes.

FRONT GEAR COVER (Contd)

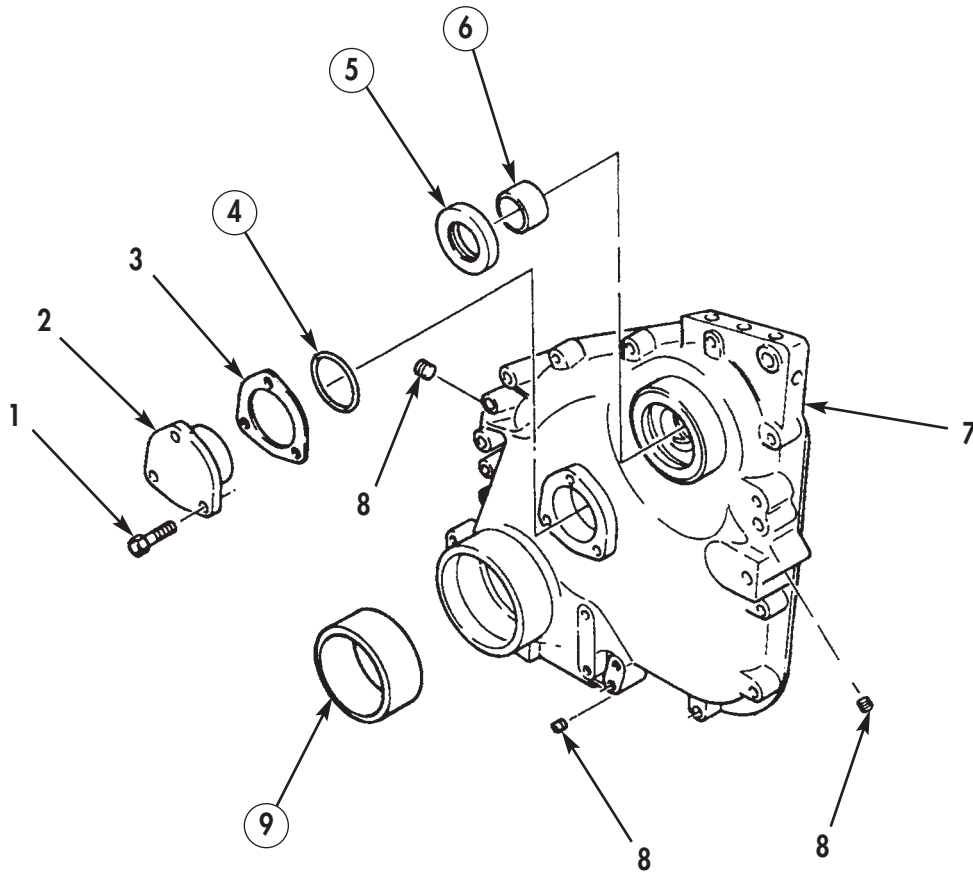


Figure 1. Front Gear Cover Disassembly.

FRONT GEAR COVER (Contd)

ASSEMBLY

CAUTION

All surfaces in contact with oil seals must be completely free of oil. Oil on a teflon seal will destroy its sealing properties.

1. Align oil holes in new sleeve bushing (6) with oil holes in front gear cover (7).
2. Using mandrel and press, install sleeve bushing (6) in front gear cover (7).
3. Apply pipe sealant to three threaded plugs (8) and install in front gear cover (7).
4. Install new O-ring (4) on camshaft support (2).
5. Install shims (3) and camshaft support (2) on front gear cover (7) with three screws (1). Tighten screws (1) 25 lb-ft (34 N•m).
6. Using puller/installer and oil seal expander, install new crankshaft oil seal (9) in front gear cover (7).
7. Using puller/installer, install new accessory drive oil seal (5) in front gear cover (7). Ensure oil seal (5) is flush with edge of front gear cover (7).
8. Install front gear cover on engine (WP 0042 00).

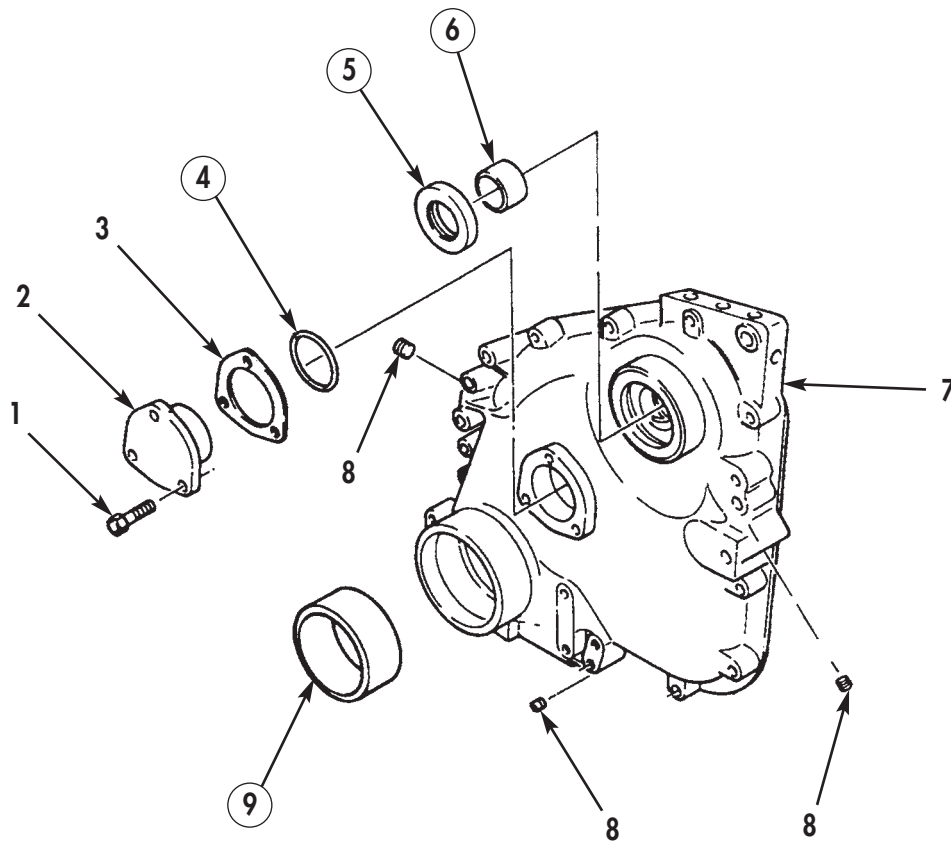


Figure 2. Front Gear Cover Assembly.

END OF WORK PACKAGE

**DIRECT SUPPORT AND GENERAL SUPPORT
MAINTENANCE MANUAL
INCLUDING REPAIR PARTS AND SPECIAL TOOLS LIST (RPSTL)**

FOR

M915, M915A1, M915A4, M916, M920 VEHICLES

NSN 2815-01-082-8125	P/N NTC400-3652-02	CUMMINS NTC-400 BIG CAM I DIESEL ENGINE W/CONTAINER
NSN 2815-01-142-2745	P/N 11669835	CUMMINS NTC-400 BIG CAM III DIESEL ENGINE W/CONTAINER

**ACCESSORY DRIVE AND ACCESSORY DRIVE PULLEY
DISASSEMBLY, CLEANING AND INSPECTION, ASSEMBLY**

INITIAL SETUP:

Tools and Special Tools

General mechanic's tool kit: automotive
(Item 1, WP 0061 00)
Maintenance and repair shop equipment:
automotive (Item 2, WP 0061 00)
Automotive maintenance and repair
supplemental set no. 2 (Item 3, WP 0061 00)
Press
Mandrel (Item 39, WP 0061 00)

Equipment Condition

Accessory drive and accessory drive pulley
removed from engine (WP 0010 00).

Materials/Parts

Lubricating oil (Item 19, WP 0060 00)
Pipe sealant (Item 25, WP 0060 00)
Sleeve (Item 1, Table 13, WP 0062 00)
Thrust bearing (Item 2, Table 13, WP 0062 00)
Thrust bearing (Item 3, Table 13, WP 0062 00)
Bushing (Item 4, Table 13, WP 0062 00)

ACCESSORY DRIVE AND ACCESSORY DRIVE PULLEY (Contd)

DISASSEMBLY

1. Using 3/8 in. (9.525 mm) cold chisel, split and remove sleeve (2) from accessory drive pulley (1). Discard sleeve (2).
2. Remove screw (12) and washer (11) from accessory drive shaft (5).

CAUTION

Install screw in accessory drive shaft when using puller.
Failure to do so may result in damage to accessory drive shaft.

3. Install screw (12) in accessory drive shaft (5). Using puller, remove spline coupling hub (10) from accessory drive shaft (5). Remove screw (12) from accessory drive shaft (5).
4. Remove washer (9) and thrust bearing (8) from accessory drive shaft (5). Discard thrust bearing (8).
5. Remove accessory drive shaft (5), with accessory drive gear (3) attached, from accessory drive housing (6).
6. Using press and mandrel, remove accessory drive gear (3) and thrust bearing (4) from accessory drive shaft (5). Discard thrust bearing (4).
7. Remove two dowel pins (14) from accessory drive shaft (5).
8. Using press and mandrel, remove bushing (7) from accessory drive housing (6). Discard bushing (7).
9. Remove threaded plug (13) from accessory drive housing (6).

CLEANING AND INSPECTION

1. For general parts cleaning information, refer to CLEANING, WP 0051 00.
2. For general parts inspection information, refer to INSPECTION, WP 0051 00.

NOTE

Replace any part that does not pass visual inspection or is outside specified wear limits.

3. Inspect front accessory drive pulley (15) and accessory drive pulley (1) for cracks and chips in hub, worn grooves, and distorted thread holes.
4. Inspect accessory drive housing (6) for cracks, stripped threads, or damaged holes. Repair any damaged threads.
5. Inspect accessory drive gear (3) and spline coupling hub (10) for cracks, chipped or stripped teeth, and uneven wear.
6. Using a micrometer or equivalent, measure accessory drive shaft bushing surface outer dimension (16). Discard accessory drive shaft (5) if accessory drive shaft bushing surface outer dimension (16) is less than 1.310 in. (3.327 cm).
7. Inspect accessory drive shaft (5) for elongated dowel pin holes and stripped threads. Repair all damaged threads.
8. Inspect two dowel pins (14) for cracks, chips, and distortion.

ACCESSORY DRIVE AND ACCESSORY DRIVE PULLEY (Contd)

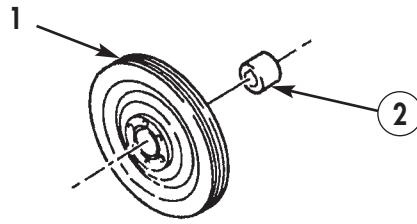


Figure 1. Accessory Drive Sleeve Removal.

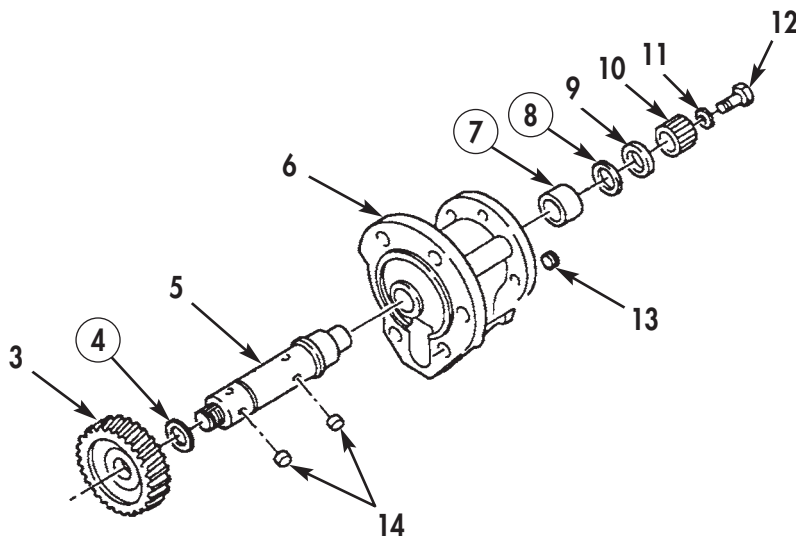


Figure 2. Accessory Drive Disassembly.

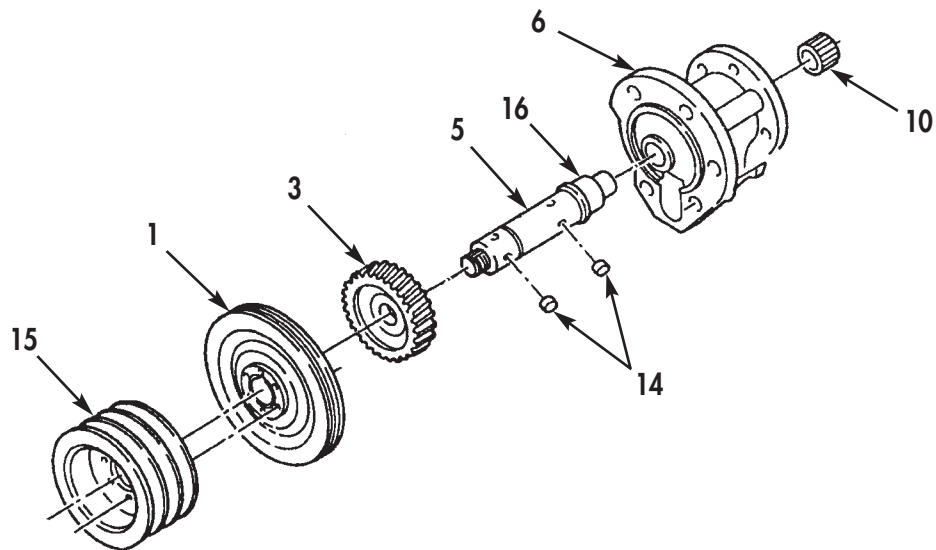


Figure 3. Accessory Drive Cleaning and Inspection.

ACCESSORY DRIVE AND ACCESSORY DRIVE PULLEY (Contd)

ASSEMBLY

NOTE

Lubricate all parts with lubricating oil before assembly.

1. Apply pipe sealant to threaded plug (11) and install threaded plug (11) in accessory drive housing (4).

NOTE

Ensure oil holes in bushing are aligned with oil hole in accessory drive housing before installing bushing.

2. Using press and mandrel, install new bushing (5) in accessory drive housing (4).
3. Install two dowel pins (12) in accessory drive shaft (3).
4. Install new thrust bearing (2) on accessory drive shaft (3).
5. Using press and mandrel, install accessory drive gear (1) on accessory drive shaft (3).
6. Install accessory drive shaft (3), with accessory drive gear (1) attached, in accessory drive housing (4).

NOTE

Ensure grooved side of thrust bearing faces away from housing during installation.

7. Install new thrust bearing (6) and washer (7) on accessory drive shaft (3).
8. Using press and mandrel, install spline coupling hub (8) on accessory drive shaft (3).
9. Using feeler gauge, measure clearance between accessory drive gear (1) and accessory drive housing (4). Allowable clearance is 0.002–0.012 in. (0.051–0.305 mm).
10. Install washer (9) and screw (10) in accessory drive shaft (3). Tighten screw (10) 30–35 lb-ft (41–48 N•m).
11. Using press and mandrel, install new sleeve (14) in accessory drive pulley (13) 0.015 in. (0.381 mm) below face of accessory drive pulley (13), with chamfered end away from accessory drive pulley (13).
12. For installation of accessory drive and accessory drive pulley, refer to WP 0042 00.

ACCESSORY DRIVE AND ACCESSORY DRIVE PULLEY (Contd)

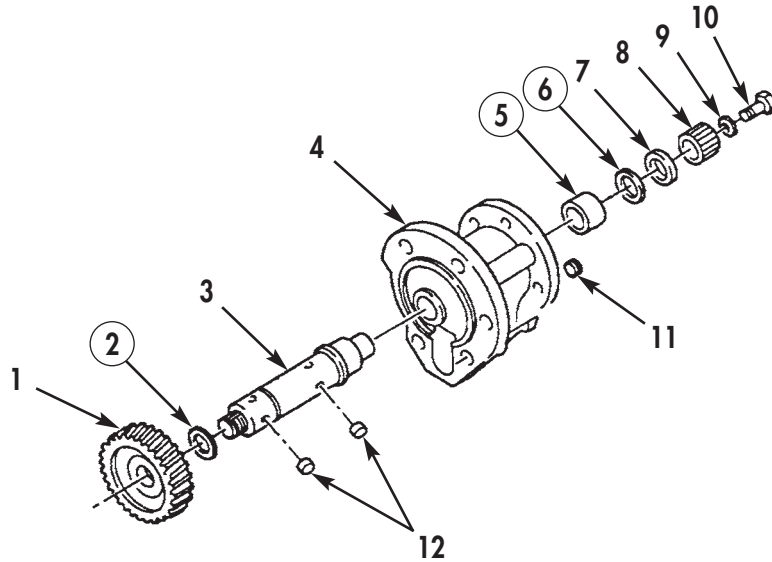


Figure 4. Accessory Drive Assembly.

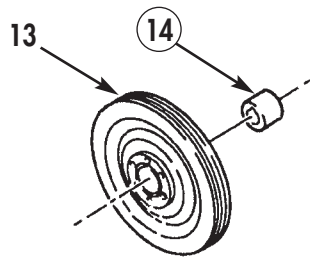


Figure 5. Accessory Drive Sleeve Installation.

**DIRECT SUPPORT AND GENERAL SUPPORT
MAINTENANCE MANUAL
INCLUDING REPAIR PARTS AND SPECIAL TOOLS LIST (RPSTL)**

FOR

M915, M915A1, M915A4, M916, M920 VEHICLES

NSN 2815-01-082-8125	P/N NTC400-3652-02	CUMMINS NTC-400 BIG CAM I DIESEL ENGINE W/CONTAINER
NSN 2815-01-142-2745	P/N 11669835	CUMMINS NTC-400 BIG CAM III DIESEL ENGINE W/CONTAINER

ENGINE RETARDER

DISASSEMBLY, CLEANING AND INSPECTION, ASSEMBLY

INITIAL SETUP:

Tools and Special Tools

General mechanic's tool kit:
 automotive (Item 1, WP 0061 00)
 Maintenance and repair shop equipment:
 automotive (Item 2, WP 0061 00)
 Automotive maintenance and repair
 supplemental set no. 2 (Item 3, WP 0061 00)
 Solenoid valve wrench (Item 6, WP 0061 00)
 C-clamp (Item 7, WP 0061 00)

Equipment Condition

Engine brake retarder removed from engine
 (WP 0011 00).

Materials/Parts

OE/HDO 10 lubricating oil
 (Item 19, WP 0060 00)
 Six outer control valve springs
 (Item 1, Table 14, WP 0062 00)
 Six inner control valve springs
 (Item 2, Table 14, WP 0062 00)
 Six upper seal rings
 (Item 3, Table 14, WP 0062 00)
 Six center seal rings
 (Item 4, Table 14, WP 0062 00)
 Six lower seal rings
 (Item 5, Table 14, WP 0062 00)
 Six slave piston springs
 (Item 6, Table 14, WP 0062 00)
 Six master piston springs
 (Item 7, Table 14, WP 0062 00)
 Six locknuts (Item 8, Table 14, WP 0062 00)

ENGINE RETARDER (Contd)

DISASSEMBLY

WARNING

Control valve cover is under control valve outer spring pressure. Hold cover securely when removing screws. Failure to comply may cause injury to personnel.

1. Remove two screws (5) and control valve covers (4) from brake housing (13).
2. Remove two outer control valve springs (2) and two inner control valve springs (3) from brake housing (13). Discard outer control valve springs (2) and inner control valve springs (3).
3. Remove two control valves (1) from brake housing (13).
4. Disconnect electrical harness (7) from solenoid valve (6).
5. Using solenoid valve wrench, remove solenoid valve (6) from brake housing (13).
6. Remove lower seal ring (10), center seal ring (9), and upper seal ring (8) from solenoid valve (6). Discard seal rings (10), (9), and (8).
7. Remove two screws (17), washers (16), master piston springs (15), and master pistons (18) from brake housing (13). Discard springs (15).
8. Remove two locknuts (11) from setscrews (12) and brake housing (13). Discard locknuts (11).
9. Remove two setscrews (12) from brake housing (13).

WARNING

Slave piston spring is highly compressed. Be extremely careful during disassembly. Personal injury can occur if spring force is not controlled.

NOTE

Perform steps 10 and 11 to remove two slave piston assemblies.

10. Using a C-clamp and deep-welled socket, compress slave piston spring (20) and remove retaining ring (22) from brake housing (13). Slowly release slave piston spring (20) pressure and remove C-clamp and deep-welled socket.
11. Remove slave piston retainer (21), slave piston spring (20), and slave piston (19) from brake housing (13). Discard spring (20).
12. Remove electrical terminal (14) from brake housing (13).
13. Repeat steps 1 through 12 for remaining two engine retarders.

CLEANING AND INSPECTION

1. For general parts cleaning information, refer to CLEANING, WP 0051 00.
2. For general parts inspection information, refer to INSPECTION, WP 0051 00.

NOTE

Replace any part that does not pass visual inspection or is outside specified wear limits.

3. Inspect slave piston retainers (21) for cracks, breaks, or bends.
4. Inspect brake housing (13) for cracks, breaks, stripped threaded holes, and scores or scratches in piston bores. Repair any stripped threaded holes.
5. Ensure control valves (1), master pistons (18), and slave pistons (19) move freely in the bores. Replace control valves (1), master pistons (18), or slave pistons (19) if any binding occurs.

ENGINE RETARDER (Contd)

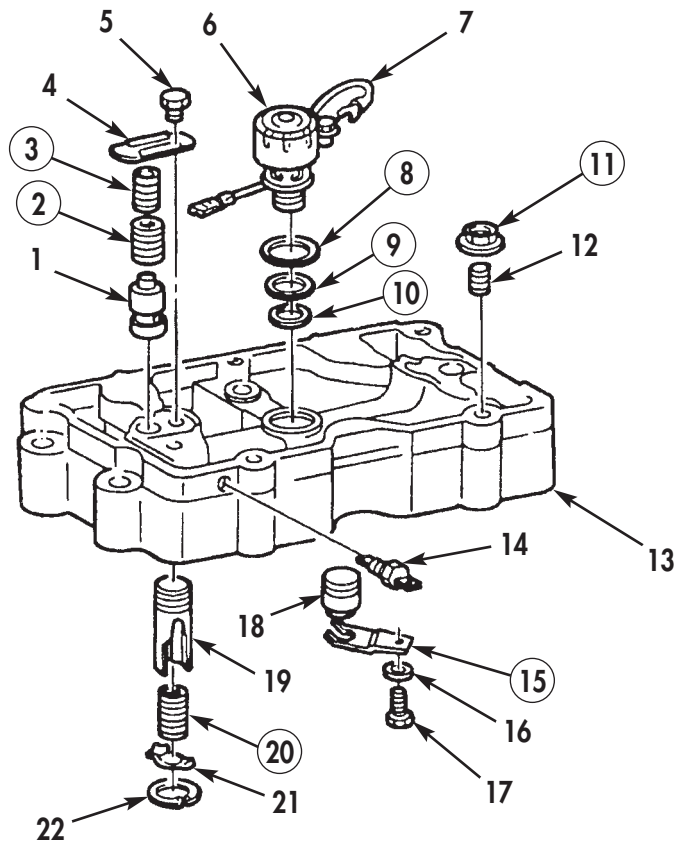


Figure 1. Engine Retarder Disassembly.

ENGINE RETARDER (Contd)

ASSEMBLY

NOTE

Lubricate all parts with OE/HDO 10 lubricating oil before assembly.

1. Install electrical terminal (14) in brake housing (13).

NOTE

Perform steps 2 and 3 to install two slave piston assemblies.

2. Install slave piston (19), new slave piston spring (20), and slave piston retainer (21) in brake housing (13).

WARNING

Slave piston spring is highly compressed. Be extremely careful during assembly. Personal injury can occur if spring force is not controlled.

3. Using a C-clamp and deep-welled socket, compress slave piston spring (20) and install retaining ring (22) in brake housing (13). Slowly release slave piston spring (20) pressure and remove C-clamp and deep-welled socket.

NOTE

Setscrews and locknuts will be tightened during engine retarder installation.

4. Install two setscrews (12) in brake housing (13). Do not tighten setscrews (12).
5. Install two new locknuts (11) on setscrews (12). Do not tighten locknuts (11).
6. Install two master pistons (18), new master piston springs (15), washers (16), and screws (17) in brake housing (13).
7. Apply OE/HDO 10 lubricating oil on new upper seal ring (8), new center seal ring (9), and new lower seal ring (10), and install on solenoid valve (6).
8. Using solenoid valve wrench, install solenoid valve (6) in brake housing (13).
9. Connect electrical harness (7) to solenoid valve (6).
10. Install two control valves (1) in brake housing (13).
11. Install two new inner control valve springs (3) and two new outer control valve springs (2) on top of control valve (1) in brake housing (13).

WARNING

Control valve cover is under control valve outer spring pressure. Hold cover securely when installing screws. Failure to comply may cause injury to personnel.

12. Install control valve cover (4) on brake housing (13) with two screws (5).
13. Repeat steps 1 through 12 for remaining two engine retarders.
14. For engine retarder installation, refer to WP 0043 00.

ENGINE RETARDER (Contd)

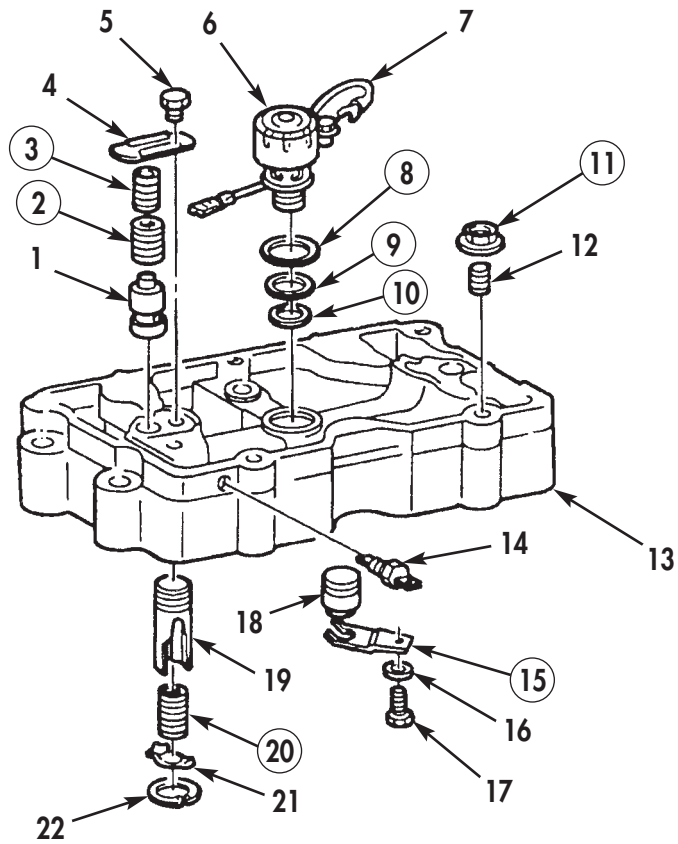


Figure 2. Engine Retarder Assembly.

**DIRECT SUPPORT AND GENERAL SUPPORT
MAINTENANCE MANUAL
INCLUDING REPAIR PARTS AND SPECIAL TOOLS LIST (RPSTL)**

FOR

M915, M915A1, M915A4, M916, M920 VEHICLES

NSN 2815-01-082-8125	P/N NTC400-3652-02	CUMMINS NTC-400 BIG CAM I DIESEL ENGINE W/CONTAINER
NSN 2815-01-142-2745	P/N 11669835	CUMMINS NTC-400 BIG CAM III DIESEL ENGINE W/CONTAINER

AIR COMPRESSOR

DISASSEMBLY, CLEANING AND INSPECTION, ASSEMBLY

INITIAL SETUP:

Tools and Special Tools

General mechanic's tool kit:
 automotive (Item 1, WP 0061 00)
 Maintenance and repair shop equipment:
 automotive (Item 2, WP 0061 00)
 Automotive maintenance and repair
 supplemental set no. 2 (Item 3, WP 0061 00)
 Air compressor mounting plate
 (Item 34, WP 0061 00)
 Ball joint vise (Item 9, WP 0061 00)
 Half coupling puller (Item 35, WP 0061 00)
 Air compressor bushing mandrel
 (Item 36, WP 0061 00)
 Line bore gauge (Item 37, WP 0061 00)
 Press
 Mandrel (Item 39, WP 0061 00)

Materials/Parts

Lubricating oil (Item 19, WP 0060 00)
 Antiseize compound (Item 7, WP 0060 00)
 Large O-ring (Item 1, Table 15, WP 0062 00)
 Small O-ring (Item 2, Table 15, WP 0062 00)
 Spring (Item 3, Table 15, WP 0062 00)
 Spring (Item 4, Table 15, WP 0062 00)
 Four lockwashers
 (Item 5, Table 15, WP 0062 00)
 Gasket (Item 6, Table 15, WP 0062 00)
 Gasket (Item 7, Table 15, WP 0062 00)
 Large O-ring (Item 8, Table 15, WP 0062 00)

Materials/Parts (Contd)

Small O-ring (Item 9, Table 15, WP 0062 00)
 Spring (Item 10, Table 15, WP 0062 00)
 Thrust bearing
 (Item 11, Table 15, WP 0062 00)
 Four lockwashers
 (Item 12, Table 15, WP 0062 00)
 Gasket (Item 13, Table 15, WP 0062 00)
 Two retaining rings
 (Item 14, Table 15, WP 0062 00)
 Piston ring (Item 15, Table 15, WP 0062 00)
 Piston ring (Item 16, Table 15, WP 0062 00)
 Piston ring (Item 17, Table 15, WP 0062 00)
 Bushing (Item 18, Table 15, WP 0062 00)
 Bearing (Item 19, Table 15, WP 0062 00)
 Cap (Item 20, Table 15, WP 0062 00)

Equipment Condition

Air compressor removed from engine
 (WP 0011 00).

AIR COMPRESSOR (Contd)

DISASSEMBLY

1. Install air compressor mounting plate on air compressor (1) with two bolts (2).
2. Install air compressor (1) and air compressor mounting plate on ball joint vise with two bolts (3).
3. Using half coupling puller, remove half coupling (4) from crankshaft (5).
4. Remove two screws (8), two washers (7), valve body (6), cap (44), and spring (43) from cover (12). Discard cap (44) and spring (43).
5. Remove large O-ring (46) and small O-ring (45) from valve body (6). Discard large O-ring (46) and small O-ring (45).
6. Remove seat (42), valve (41), and spring (40) from cylinder head (14). Discard spring (40).
7. Remove four bolts (9), lockwashers (10), washers (11), cover (12), and gasket (13) from cylinder head (14). Discard lockwashers (10) and gasket (13).
8. Remove cylinder head (14) and gasket (15) from cylinder housing (24). Discard gasket (15).
9. Using press and mandrel, remove seat (38) from bottom of cylinder head (14).
10. Remove large O-ring (39) and small O-ring (37) from seat (38). Discard large O-ring (39) and small O-ring (37).

NOTE

Do not discard shim. Shim will be reused during installation.

11. Remove disc (36), spring (35), and shim (34) from cylinder head (14). Discard spring (35).
12. Remove two screws (22) and plate (23) from cylinder housing (24).
13. Remove drive coupling (33) from crankshaft (5) if not previously removed.
14. Remove thrust bearing (32) from crankshaft (5). Discard thrust bearing (32).
15. Remove two screws (25) securing support (29) to cylinder housing (24).
16. Remove four screws (31), lockwashers (30), support (29), and gasket (28) from cylinder housing (24). Discard lockwashers (30) and gasket (28).
17. Rotate piston (20) 90° before or after top dead center.
18. Rotate crankshaft (5) while pulling out and remove crankshaft (5) from connecting rod (21) and cylinder housing (24).
19. Remove pipe plug (27) from crankshaft (5).
20. Using a ridge reamer, remove any ridge or carbon deposits from top of cylinder housing (24).
21. Remove piston (20) and connecting rod (21) out through top of cylinder housing (24).
22. Remove two retaining rings (17) from piston (20). Discard retaining rings (17).

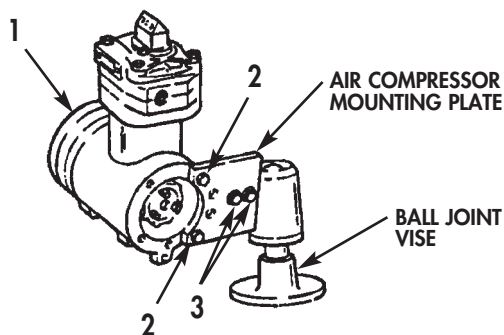


Figure 1. Mounting Air Compressor on Stand.

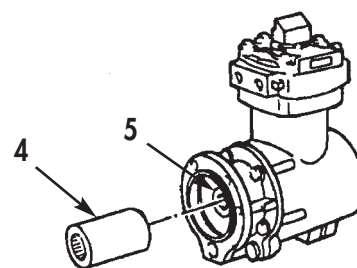


Figure 2. Half Coupling Removal.

AIR COMPRESSOR (Contd)

DISASSEMBLY (Contd)

WARNING

Use gloves during piston pin removal if piston has been soaked in hot water. Failure to comply may result in injury to personnel.

CAUTION

Do not force or drive piston pin out from piston bore. If piston cannot be removed by hand, soak piston assembly in hot water to expand piston bore and allow for removal of piston pin. Failure to comply may result in damage to piston.

23. Remove piston pin (19) and piston (20) from connecting rod (21).

CAUTION

Do not scratch or score piston during piston ring removal. Failure to comply may result in damage to piston.

24. Remove three piston rings (18) from piston (20). Discard piston rings (18).
 25. Using press and mandrel, remove bushing (16) from connecting rod (21). Discard bushing (16).
 26. Using press and air compressor bushing, remove bearing (26) from cylinder housing (24). Discard bearing (26).

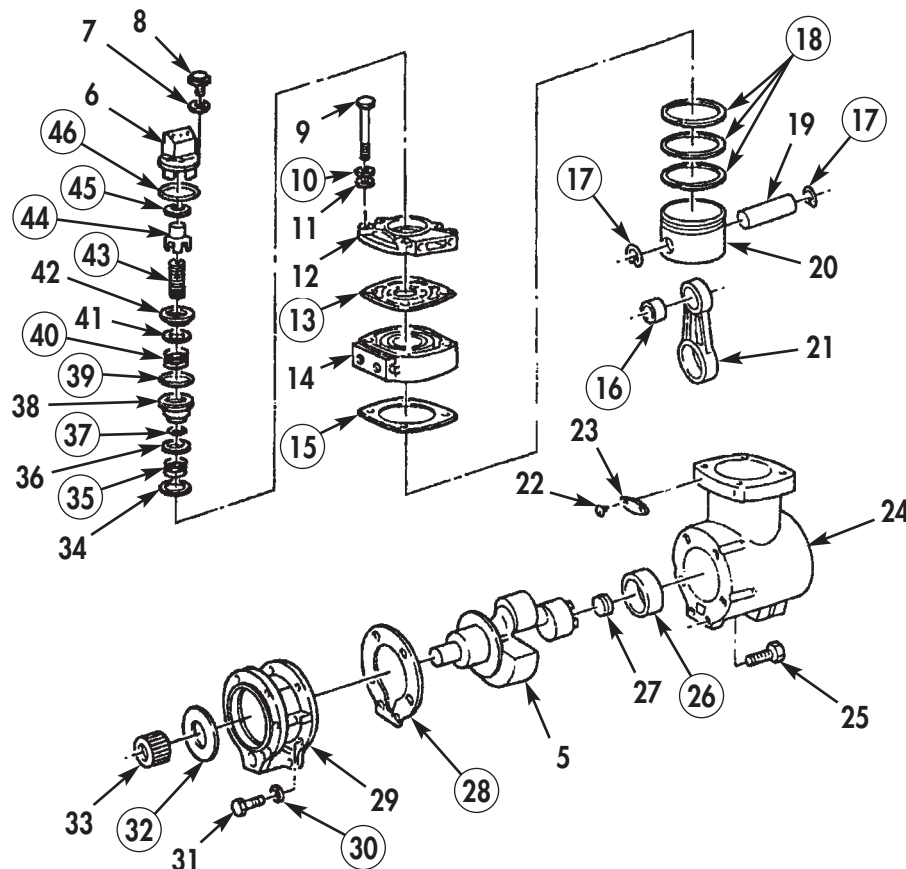


Figure 3. Air Compressor Disassembly.

AIR COMPRESSOR (Contd)

CLEANING AND INSPECTION

1. For general parts cleaning information, refer to CLEANING, WP 0051 00.
2. For general parts inspection information, refer to INSPECTION, WP 0051 00.

CAUTION

Cylinder head top surface is contoured. Do not grind or machine cylinder head. Failure to do so will cause cylinder head leakage and damage to air compressor.

NOTE

Replace any part that does not pass visual inspection or is outside specified wear limits.

3. Inspect cylinder head (1) and cover (2) mating surfaces for scratches, scoring, cracks and pitting.
4. Inspect drive coupling (9) for chipped or stripped teeth, and cracks.
5. Inspect support (8) for cracks, scratches, and scores.
6. Inspect connecting rod (5) inside diameters for scratches, scoring and cracks.
7. Using straight edge and feeler gauge, measure connecting rod (5) for bend and twist. Discard connecting rod (5) if bend is greater than 0.002 in. (0.508 mm) maximum, and twist maximum is greater than 0.004 in. (0.102 mm).
8. Using inside micrometer, measure connecting rod (5) crankshaft end inside diameter. Maximum diameter is 1.935 in. (49.149 mm). Discard connecting rod (5) if maximum diameter is exceeded.
9. Inspect cylinder housing (6) for scratches, scoring, and cracks.
10. Using a line bore gauge, measure cylinder housing (6) bore inside diameter and bore out-of-round dimensions. Maximum cylinder housing (6) inside bore diameter allowed is 3.6285 in. (9.2164 cm). Maximum cylinder housing (6) bore out-of-round dimension allowed is 0.0015 in. (0.0381 mm). Discard cylinder housing (6) if either measurement is over limit.
11. Hone bore of cylinder housing (6) to remove glaze.
12. Inspect piston (3) for scoring, pitting, chips, or cracks.
13. Using inside micrometer, measure piston pin (3) bore. Replace piston (3) if piston pin bore is above 0.6885 in. (17.4879 mm).
14. Using micrometer or equivalent, measure piston pin (4) outside diameter. Replace piston pin (4) if outside diameter is above 0.6876 in. (17.4625 mm).
15. Position a new piston ring (11) in piston ring groove (10). Using a feeler gauge, check the clearance between piston ring (11) and piston ring groove (10). Discard piston (9) if clearance is more than 0.004 in. (0.1016 mm).
16. Position a new piston ring (11) in top of cylinder housing (6) bore. Using a feeler gauge, measure piston ring (11) end gap. Piston ring (11) gap must be between 0.010–0.020 in. (0.254–0.508 mm). If correct gap cannot be obtained, replace piston ring (11).

AIR COMPRESSOR (Contd)

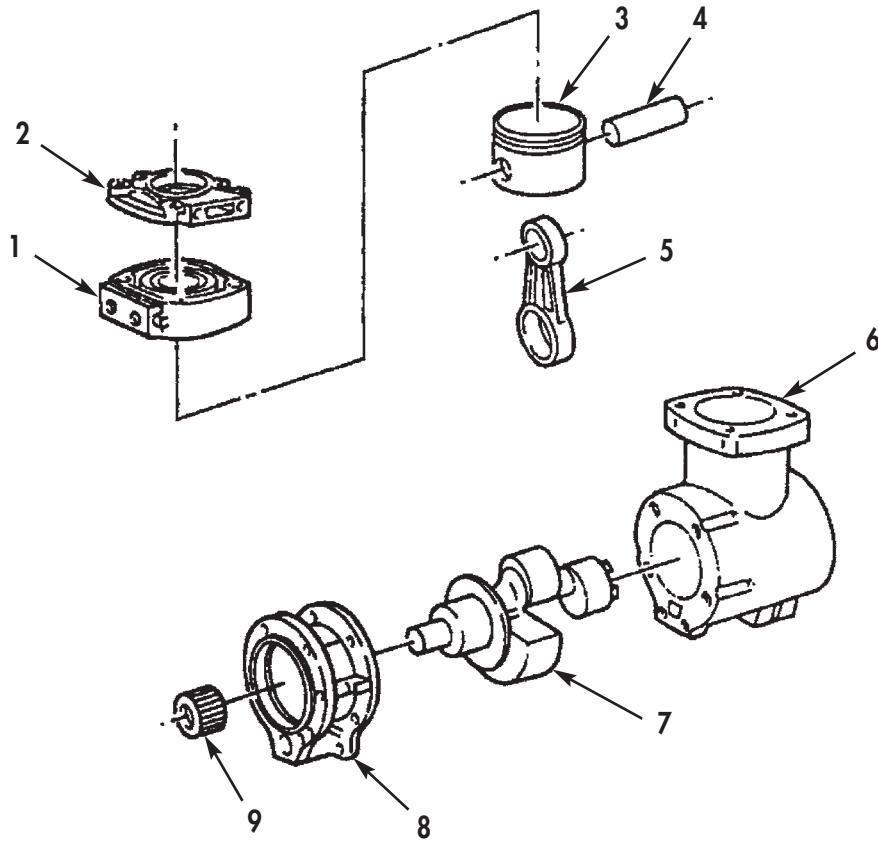


Figure 4. Air Compressor Inspection.

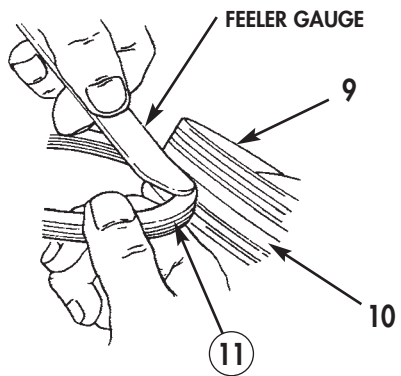


Figure 5. Piston Ring Groove Measurement.

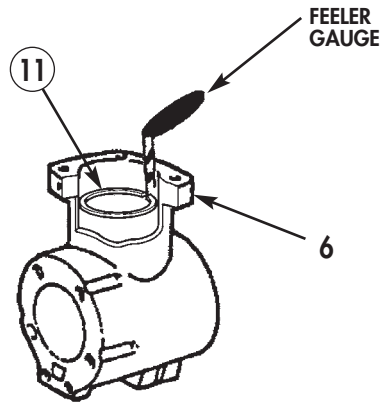


Figure 6. Piston Ring Gap Measurement.

AIR COMPRESSOR (Contd)**CLEANING AND INSPECTION (Contd)**

17. Using micrometer, measure all crankshaft (1) journals. Refer to table 1 for crankshaft (1) journal measurements. Replace crankshaft (1) if any journal is beyond specifications.

Table 1. Crankshaft Journal Specifications.

CRANKSHAFT JOURNAL	MINIMUM	MAXIMUM	WEAR LIMIT
Front Support Journal	1.872 in. (4.755 cm)	1.873 in. (4.757 cm)	1.871 in (4.752 cm)
Half Coupling Journal	1.003 in. (2.548 cm)	1.0035 in. (2.549 cm)	—
Rear Coupling Journal	1.872 in. (4.755 cm)	1.873 in. (4.757 cm)	1.933 in. (4.910 cm)

18. Using depth micrometer, measure seat (2) height. Seat height minimum is 0.485 in. (12.319 mm). Discard seat (2) if below minimum.
19. Using depth micrometer, measure height of seating area on seat (2). Seating area height minimum is 0.270 in. (6.858 mm). Discard seat (2) if below minimum.
20. Using depth micrometer, measure support thrust flange (3) depth. Support (3) thrust flange should be 1.307–1.310 in. (3.320–3.327 cm).

AIR COMPRESSOR (Contd)

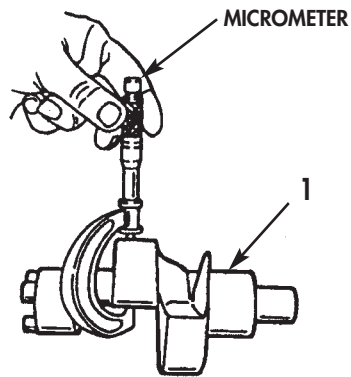


Figure 7. Crankshaft Measurement.

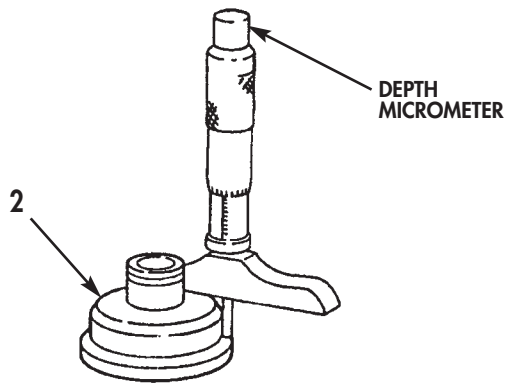


Figure 8. Seat Measurement.

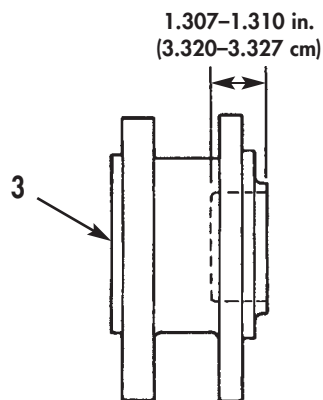


Figure 9. Support Measurement.

AIR COMPRESSOR (Contd)

ASSEMBLY

NOTE

Apply lubricating oil on new bushing and new bearing before installation.

1. Using press and mandrel, install new bushing (11) in connecting rod (16).
2. Using press and mandrel, install new bearing (21) in cylinder housing (19).

WARNING

Use gloves during piston pin installation if piston has been soaked in hot water. Failure to comply may result in injury to personnel.

CAUTION

Do not force or drive piston pin in piston bore. If piston pin cannot be installed by hand, soak piston assembly in hot water to expand piston bore to allow for installation of piston pin. Failure to comply may result in damage to piston.

3. Install piston (15) on connecting rod (16) with piston pin (14).
4. Install two new retaining rings (12) in piston (15).

CAUTION

Do not scratch or score piston during piston ring removal. Failure to comply may result in damage to piston.

NOTE

Piston rings are marked with word "top". Install piston rings with word "top" facing up.

5. Apply lubricating oil to three new piston rings (13) and install on piston (15).
6. Stagger piston rings (13) gap 180° apart and ensure they are not positioned over piston pin bore. Install ring compressor on piston (15) and compress piston rings (13).

CAUTION

Do not force piston in cylinder housing bore. Excessive force will crack piston rings. Failure to comply may result in damage to equipment.

7. Position piston (15) with connecting rod (16) attached, in cylinder housing (19) bore. Using hammer with wood handle or equivalent, install connecting rod (16) and piston (15) in cylinder housing (19) by tapping piston (15) with wood end of hammer.
8. Install pipe plug (22) in crankshaft (23).
9. Rotate piston (15) 90° before or after top dead center in cylinder housing (19). To allow for crankshaft (23) installation.
10. Apply lubricating oil to crankshaft (23), connecting rod (16), bearing (21), and cylinder housing (19).
11. Rotate crankshaft (23) while pushing in to install crankshaft (23) in connecting rod (16) and cylinder housing (19).
12. Install new gasket (24) and support (25) on crankshaft (23) and cylinder housing (19) with six new lockwashers (26) and screws (27). Tighten screws (27) 30–35 lb-ft (41–47 N•m).
13. Apply lubricating oil to new thrust bearing (28) and install on crankshaft (23).
14. Apply lubricating oil to half coupling (29). Using press, install half coupling (29) on crankshaft (23).

AIR COMPRESSOR (Contd)

ASSEMBLY (Contd)

15. Install plate (18) on cylinder housing (19) with two screws (17).
16. Apply lubricating oil to new large O-ring (35) and new small O-ring (33) and install on seat (34).
17. Install disc (32) on seat (34).

NOTE

Use shim previously removed during disassembly for assembly.

18. Install shim (30), new spring (31), seat (34), with disc (32) attached, in cylinder head (9).
19. Install new spring (36), valve (37), and seat (38) in cylinder head (9).
20. Install new gasket (10), cylinder head (9), new gasket (8), and cover (7) on cylinder housing (19) with four washers (6), new lockwashers (5), and bolts (4). Tighten bolts (4) 15–19 lb-ft (20–26 N•m).
21. Apply lubricating oil to new large O-ring (42) and and install on valve body (1).
22. Apply lubricating oil to new small O-ring (41) and install on valve body (1).
23. Install new spring (39), new cap (40), and valve body (1) on cover (7) with two washers (2) and screws (3). Tighten screws (3) 96–132 lb-in (11–15 N•m).

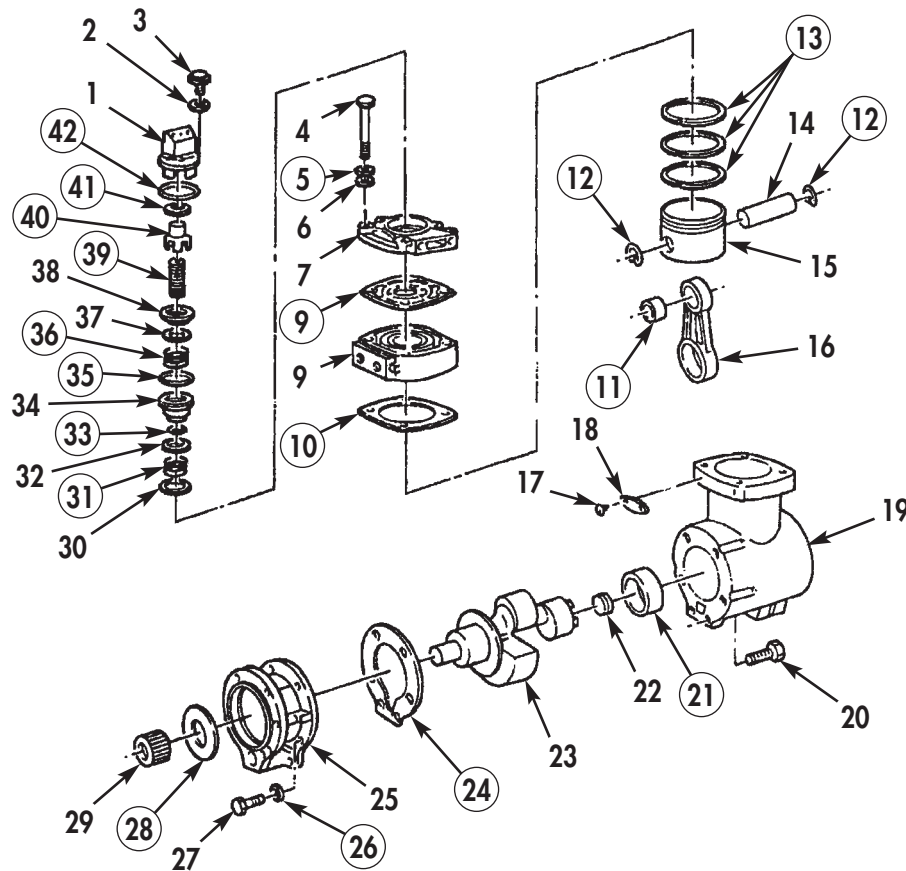


Figure 10. Air Compressor Assembly.

AIR COMPRESSOR (Contd)

ASSEMBLY (Contd)

24. Install drive coupling (1) on half coupling (2) if not previously removed.
25. Remove two bolts (5), air compressor mounting plate, and air compressor (3) from ball joint vise.
26. Remove two bolts (4) and air compressor (3) from air compressor mounting plate.
27. For air compressor installation, refer to WP 0042 00.

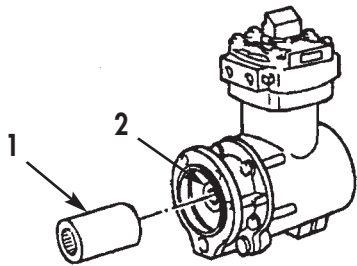


Figure 11. Drive Coupling Installation.

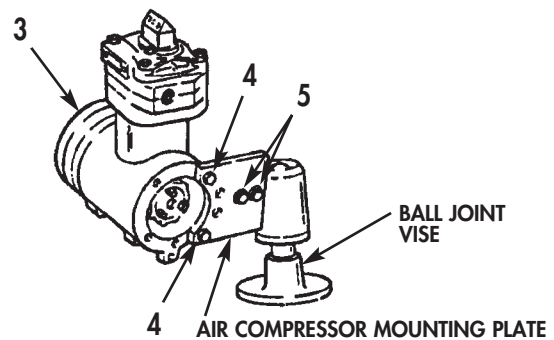


Figure 12. Removing Air Compressor from Stand.

**DIRECT SUPPORT AND GENERAL SUPPORT
MAINTENANCE MANUAL
INCLUDING REPAIR PARTS AND SPECIAL TOOLS LIST (RPSTL)**

FOR

M915, M915A1, M915A4, M916, M920 VEHICLES

NSN 2815-01-082-8125	P/N NTC400-3652-02	CUMMINS NTC-400 BIG CAM I DIESEL ENGINE W/CONTAINER
NSN 2815-01-142-2745	P/N 11669835	CUMMINS NTC-400 BIG CAM III DIESEL ENGINE W/CONTAINER

**FUEL INJECTOR
DISASSEMBLY, CLEANING AND INSPECTION, ASSEMBLY**

INITIAL SETUP:

Tools and Special Tools

General mechanic's tool kit:
automotive (Item 1, WP 0061 00)
Maintenance and repair shop equipment:
automotive (Item 2, WP 0061 00)
Automotive maintenance and repair
supplemental set no. 2 (Item 3, WP 0061 00)
Injector stand (Item 11, WP 0061 00)
Body and injector cup wrench
(Item 12, WP 0061 00)

Equipment Condition

Fuel injector removed from engine
(WP 0011 00).

Materials/Parts

Lubricating oil (Item 19, WP 0060 00)
Prussian blue (Item 9, WP 0060 00)
Diesel fuel (Item 18, WP 0060 00)
Spring (Item 1, Table 16, WP 0062 00)
Three gaskets (Item 2, Table 16, WP 0062 00)
Filter screen (Item 3, Table 16, WP 0062 00)
Gasket (Item 4, Table 16, WP 0062 00)

FUEL INJECTOR (Contd)

DISASSEMBLY

WARNING

Do not perform fuel system procedures while smoking or within 50 ft (15.2 m) of sparks or open flame. Diesel fuel is flammable and may explode. Failure to comply may result in injury or death to personnel.

1. Remove top-stop locknut (2) and top-stop screw (3) from top-stop adapter (6).
2. Remove plunger (1), washer (4), and injector spring (5) from top-stop adapter (6). Discard spring (5).
3. Remove three gaskets (7) from top-stop adapter (6). Discard gaskets (7).

CAUTION

Do not change position of orifice plug located behind filter screen. Orifice plug has been pre-set. Damage to injector or improper fuel delivery will result if orifice plug is adjusted.

4. Remove filter screen clip (13), filter screen (14), and gasket (15) from top-stop adapter (6). Discard filter screen (14) and gasket (15).
5. Install injector in injector stand. Using body and injector cup wrench, loosen cup retainer (12) on top-stop adapter (6). Remove injector from injector stand.
6. Remove cup retainer (12) from top-stop adapter (6).

CAUTION

Do not pry against machined surface when removing roll pins. Damage to machined surface may result.

7. Remove barrel (10) and injector cup (11) from cup retainer (12).
8. Remove two roll pins (8) and check ball (9) from barrel (10).

CLEANING AND INSPECTION

1. For general parts cleaning information, refer to CLEANING, WP 0051 00.
2. For general parts inspection information, refer to INSPECTION, WP 0051 00.

NOTE

Replace any part that does not pass visual inspection or is outside specified wear limits.

3. Inspect cup retainer (12) for stripped threads, nicks and burrs.
4. Inspect top-stop adapter (6) for stripped threads.
5. Inspect top-stop adapter (6) for nicks and burrs around gasket sealing area and mating surfaces.
6. Inspect top-stop adapter (6) for obstructions around orifice and fuel passage openings.
7. Inspect check ball (9) for nicks and burrs.
8. Using a depth micrometer, measure barrel (10) ball seat depth. Maximum barrel (10) ball seat depth allowed is 0.050 in. (1.27 mm).
9. Inspect barrel (10) for scoring, nicks and burrs.
10. Inspect barrel (10) for carbon, burrs, distorted radius, and blockage.
11. Inspect barrel (10) for loose or cracked fuel passages.

FUEL INJECTOR (Contd)

CLEANING AND INSPECTION (Contd)

12. Inspect plunger (1) for scuffing or scoring.
13. Inspect injector cup (11) for enlarged or distorted spray holes.
14. Apply prussian blue to plunger (1) and install in cup (11) and rotate 90° to check plunger seat pattern. If less than 40% of seat area is covered, replace cup (11).

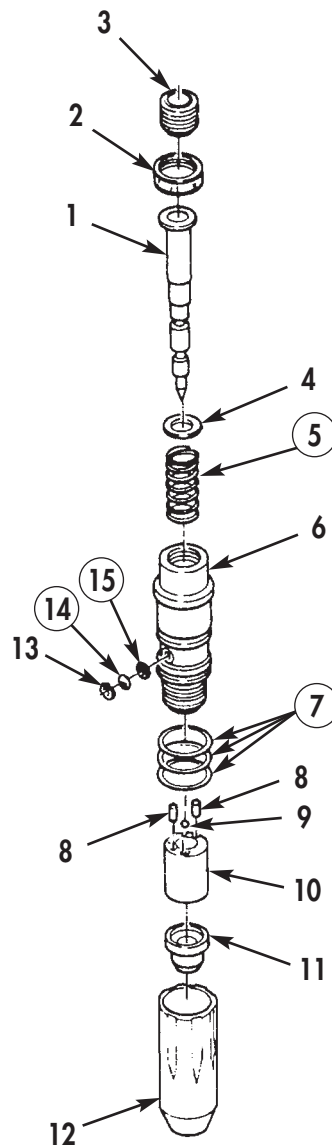


Figure 1. Fuel Injector Disassembly.

FUEL INJECTOR (Contd)

ASSEMBLY

WARNING

Do not perform fuel system procedures while smoking or within 50 ft (15.2 m) of sparks or open flame. Diesel fuel is flammable and may explode. Failure to comply may result in injury or death to personnel.

NOTE

Apply lubricating oil to all parts before assembly.

1. Install check ball (9) on barrel (10).
2. Install two roll pins (8) in barrel (10).
3. Install barrel (10) and injector cup (11) in top-stop adapter (6). Ensure check ball (9) stays positioned on barrel (10).
4. Install cup retainer (12) on top-stop adapter (6) finger tight.
5. Install plunger (1) in top-stop adapter (6).
6. Install injector in injector stand. Tighten stud on injector stand 75 lb-in. (8.5 N•m) to align injector cup (11) with plunger (1). Using body and injector cup wrench, tighten cup retainer (12) 53–57 lb-ft (72–77 N•m). Remove injector from injector stand.

NOTE

To check plunger to injector cup alignment, perform steps 7 through 12.

7. Remove plunger (1) from top-stop adapter (6) and coat plunger (1) with diesel fuel.
8. Allow diesel fuel to run off plunger (1) into top-stop adapter (6) and barrel (10).
9. Install plunger (1) in barrel (10) leaving a 0.050 in. (1.27 mm) gap between top of plunger (1) and top-stop adapter (6).
10. Seat plunger (1) in injector cup (11) by pushing down.
11. Hold plunger (1) firmly in injector cup (11) and rotate 90°.
12. Turn injector over and release plunger (1). Plunger (1) should slide out immediately. If plunger (1) does not slide out. Plunger (1) and injector cup (11) are not aligned. Disassemble injector and realign.
13. Repeat steps 7 through 12 until correct plunger (1) to injector cup (11) alignment is obtained.
14. Install three new gaskets (7) on top-stop adapter (6).

CAUTION

Do not change position of orifice plug located behind filter screen. orifice plug has been pre-set. Damage to injector or improper fuel delivery will result if orifice plug is adjusted.

15. Install new gasket (15), new filter screen (14), and filter screen clip (13) in top-stop adapter (6).
16. Install new injector spring (5), washer (4), and plunger (1) in top-stop adapter (6).
17. Install top-stop locknut (2) and top-stop screw (3) in top-stop adapter (6).
18. For installation of fuel injector, refer to WP 0043 00.

FUEL INJECTOR (Contd)

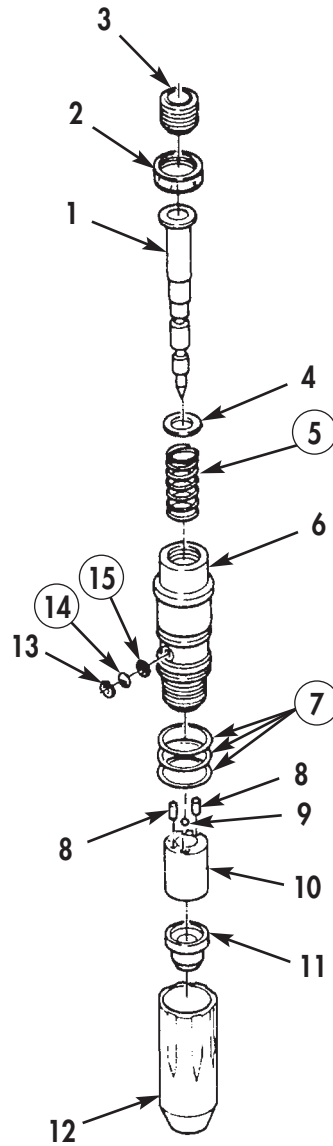


Figure 2. Fuel Injector Assembly.

**DIRECT SUPPORT AND GENERAL SUPPORT
MAINTENANCE MANUAL
INCLUDING REPAIR PARTS AND SPECIAL TOOLS LIST (RPSTL)**

FOR

M915, M915A1, M915A4, M916, M920 VEHICLES

NSN 2815-01-082-8125	P/N NTC400-3652-02	CUMMINS NTC-400 BIG CAM I DIESEL ENGINE W/CONTAINER
NSN 2815-01-142-2745	P/N 11669835	CUMMINS NTC-400 BIG CAM III DIESEL ENGINE W/CONTAINER

FUEL PUMP DISASSEMBLY

**SOLENOID VALVE, FUEL DAMPER AND HEAD, FUEL GEAR PUMP,
FUEL PUMP GOVERNOR SPRING, FUEL PUMP FRONT COVER AND GOVERNOR**

INITIAL SETUP:

Tools and Special Tools

General mechanic's tool kit: automotive
(Item 1, WP 0061 00)
Maintenance and repair shop equipment:
automotive (Item 2, WP 0061 00)
Automotive maintenance and repair
supplemental set no. 2 (Item 3, WP 0061 00)
Ball joint vise (Item 9, WP 0061 00)
Fuel pump mounting plate
(Item 10, WP 0061 00)

Equipment Condition

Fuel pump removed from engine
(WP 0010 00).

FUEL PUMP DISASSEMBLY (Contd)

SOLENOID VALVE

1. Install fuel pump (2) on fuel pump mounting plate with two screws (1) and nuts (3).
2. Install fuel pump mounting plate with fuel pump (2) attached on ball joint vise with two screws (4).
3. Remove two screws (5), lockwashers (6), washers (7), solenoid valve (8), and two rectangular ring seals (9) from fuel pump (2). Discard rectangular ring seals (9) and lockwashers (6).
4. Repair solenoid valve (WP 0034 00).

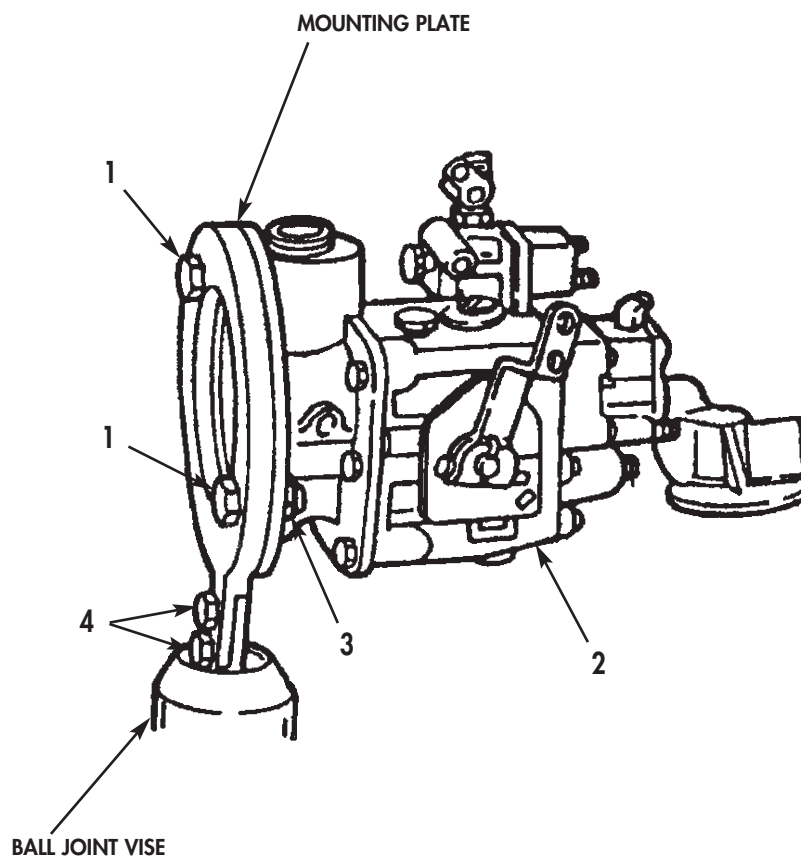


Figure 1. Fuel Pump Disassembly.

FUEL PUMP DISASSEMBLY (Contd)

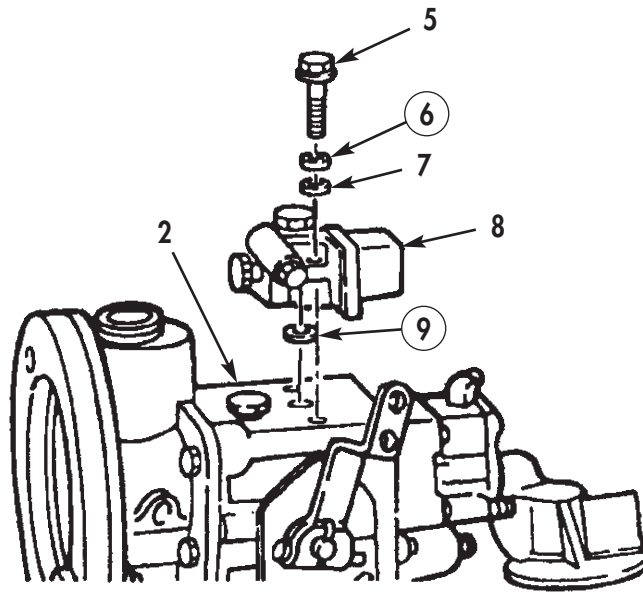


Figure 2. Solenoid Valve Removal.

FUEL PUMP DISASSEMBLY (Contd)

FUEL DAMPER AND HEAD

1. Remove four screws (4), lockwashers (3), washers (2), and filter head (1) from fuel pump (5). Discard lockwashers (3).
2. Remove two rectangular seal rings (6) and (7) from filter head (1). Discard rectangular seal rings (6) and (7).
3. Repair fuel damper and head (WP 0035 00).

FUEL GEAR PUMP

1. Remove four screws (10), lockwashers (9), gasket (8), and fuel gear pump assembly (11) from fuel pump (5). Discard lockwashers (9) and gasket (8).
2. Repair fuel gear pump (WP 0036 00).

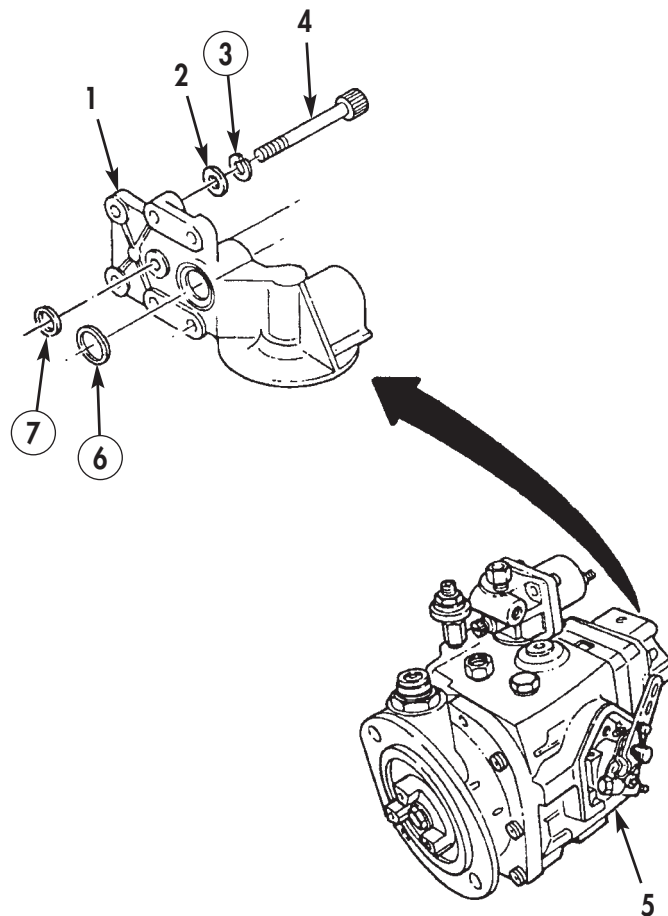


Figure 3. Fuel Damper and Head Removal.

FUEL PUMP DISASSEMBLY (Contd)

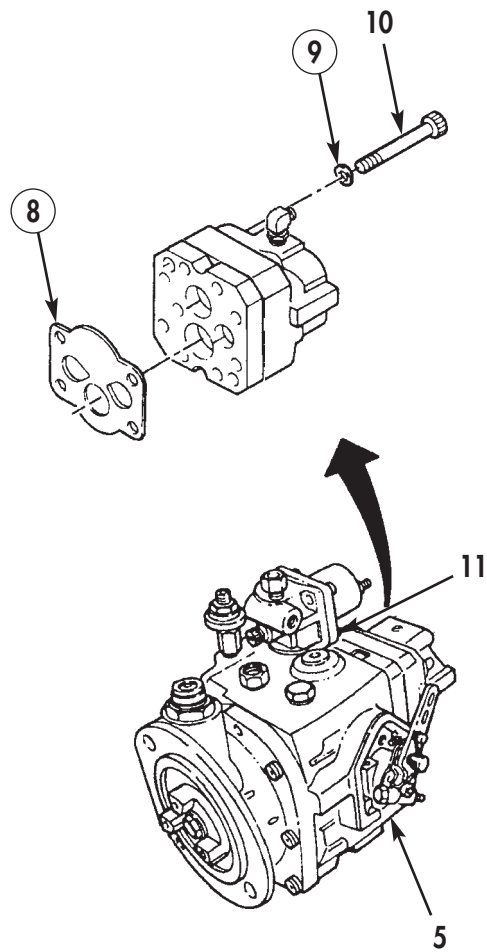


Figure 4. Fuel Gear Pump Removal.

FUEL PUMP DISASSEMBLY (Contd)

FUEL PUMP GOVERNOR SPRING

1. Remove wire (7) and adjusting screw seal (8) from cover plug (9). Discard wire (7) and adjusting screw seal (8).
2. Remove four screws (6), washers (5), spring pack cover (4), and gasket (3) from fuel pump (10). Discard gasket (3).
3. Remove snapping (2) and fuel pump governor spring assembly (1) from fuel pump (10).
4. Repair fuel pump governor spring (WP 0037 00).

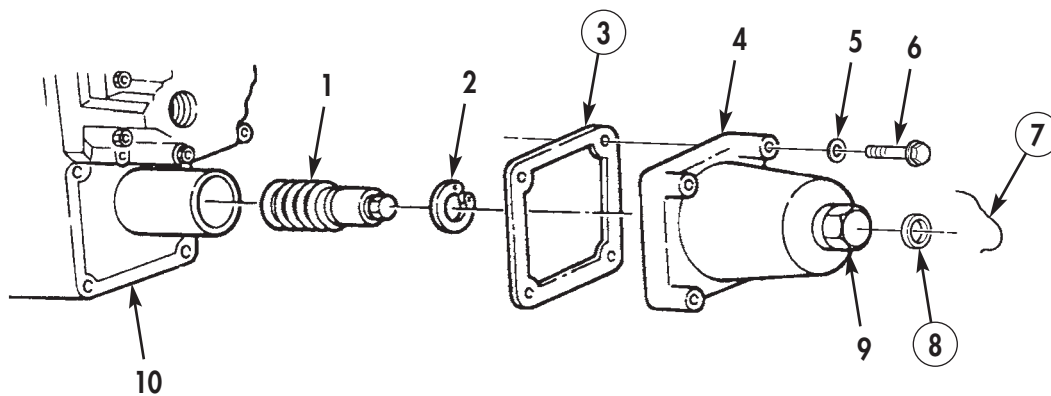


Figure 5. Fuel Pump Governor Spring Removal.

FUEL PUMP DISASSEMBLY (Contd)

FUEL PUMP FRONT COVER AND GOVERNOR

1. Remove screw (11) and plastic bushing seal (12) from fuel pump front cover (13). Discard plastic bushing seal (12).
2. Remove screw (20), lockwasher (19), and washer (18) securing fuel pump front cover (13) to fuel pump (16). Discard lockwasher (19).
3. Remove five screws (17), fuel pump main housing (15), and gasket (14) from fuel pump front cover (13). Discard gasket (14).
4. Repair fuel pump front cover and governor (WP 0038 00).

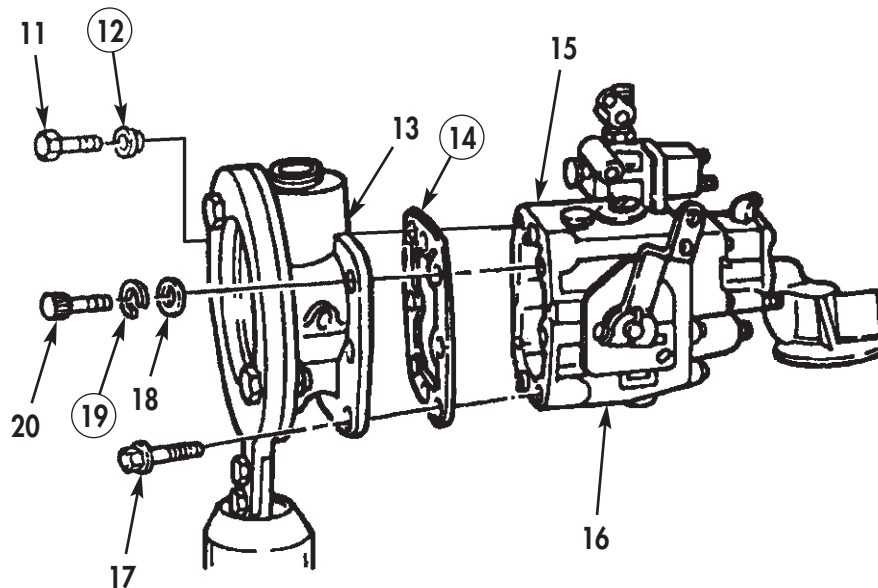


Figure 6. Fuel Pump Cover and Governor Removal.

END OF WORK PACKAGE

**DIRECT SUPPORT AND GENERAL SUPPORT
MAINTENANCE MANUAL
INCLUDING REPAIR PARTS AND SPECIAL TOOLS LIST (RPSTL)**

FOR

M915, M915A1, M915A4, M916, M920 VEHICLES

NSN 2815-01-082-8125	P/N NTC400-3652-02	CUMMINS NTC-400 BIG CAM I DIESEL ENGINE W/CONTAINER
NSN 2815-01-142-2745	P/N 11669835	CUMMINS NTC-400 BIG CAM III DIESEL ENGINE W/CONTAINER

SOLENOID VALVE

DISASSEMBLY, CLEANING AND INSPECTION, ASSEMBLY

INITIAL SETUP:

Tools and Special Tools

General mechanic's tool kit: automotive
(Item 1, WP 0061 00)
Maintenance and repair shop equipment:
automotive (Item 2, WP 0061 00)
Automotive maintenance and repair
supplemental set no. 2 (Item 3, WP 0061 00)

Equipment Condition

Solenoid valve removed from fuel pump
(WP 0033 00).

Material/Parts

Lint-free cloth (Item 6, WP 0060 00)
Lubricating oil (Item 19, WP 0060 00)
Rectangular ring seal
(Item 1, Table 17, WP 0062 00)
O-ring (Item 2, Table 17, WP 0062 00)
Shutoff valve spring
(Item 3, Table 17, WP 0062 00)
Valve disc (Item 4, Table 17, WP 0062 00)

SOLENOID VALVE (Contd)

DISASSEMBLY

1. Remove four screws (10), electrical solenoid (9), shutoff valve shield (8), rectangular ring seal (7), shutoff valve spring (6), and valve disc (5) from valve body (2). Discard rectangular ring seal (7), shutoff valve spring (6), and valve disc (5).

NOTE

Turn knob and shaft clockwise. Threads on shaft will act as a puller.

2. Remove shutoff valve knob (1) from shutoff valve shaft (3).
3. Remove shutoff valve shaft (3), with O-ring (4) attached, from valve body (2). Discard O-ring (4).
4. Remove plug (11) from valve body (2).

CLEANING AND INSPECTION

1. For general parts cleaning information, refer to CLEANING, WP 0051 00.
2. For general parts inspection information, refer to INSPECTION, WP 0051 00.

NOTE

Replace any part that does not pass visual inspection or that is outside specified wear limits.

3. Wipe electrical solenoid (9) clean with lint-free cloth.
4. Inspect valve seat on valve body (2) for wear, bonding separation, failure, and corrosion. Discard valve seat if damaged or worn.
5. Using micrometer, measure width of valve seat. Discard valve body (2) if width of valve seat is less than 0.015 in. (0.381 mm).
6. Using multimeter, check electrical solenoid (9) resistance between long terminal and base. Discard electrical solenoid (9) if resistance is not within 28–32 ohms.

ASSEMBLY

1. Apply light coat of lubricating oil to new O-ring (4) and shutoff valve shaft (3), and install O-ring (4) on shutoff valve shaft (3).
2. Turn shutoff valve shaft (3) in valve body (2) until it reaches bottom of bore.
3. Using depth micrometer, position shutoff valve shaft (3) tip 0.118 in. (2.997 mm) from face of valve body (2). Adjust shutoff valve shaft (3) until correct clearance is obtained.
4. Without moving shutoff valve shaft (3), press shutoff valve knob (1) on shutoff valve shaft (3) until fully seated.
5. Install new valve disc (5) in valve body (2) with rubber side toward valve body (2).
6. Apply lubricating oil to new rectangular ring seal (7) and install in valve body (2).
7. Install new shutoff valve shaft spring (6) in valve body (2) with concave side up.
8. Install shutoff valve shield (8) and electrical solenoid (9) on valve body (2) with four screws (10). Tighten screws 25–30 lb-ft (34–40 N•m).
9. Install solenoid valve (WP 0040 00).

SOLENOID VALVE (Contd)

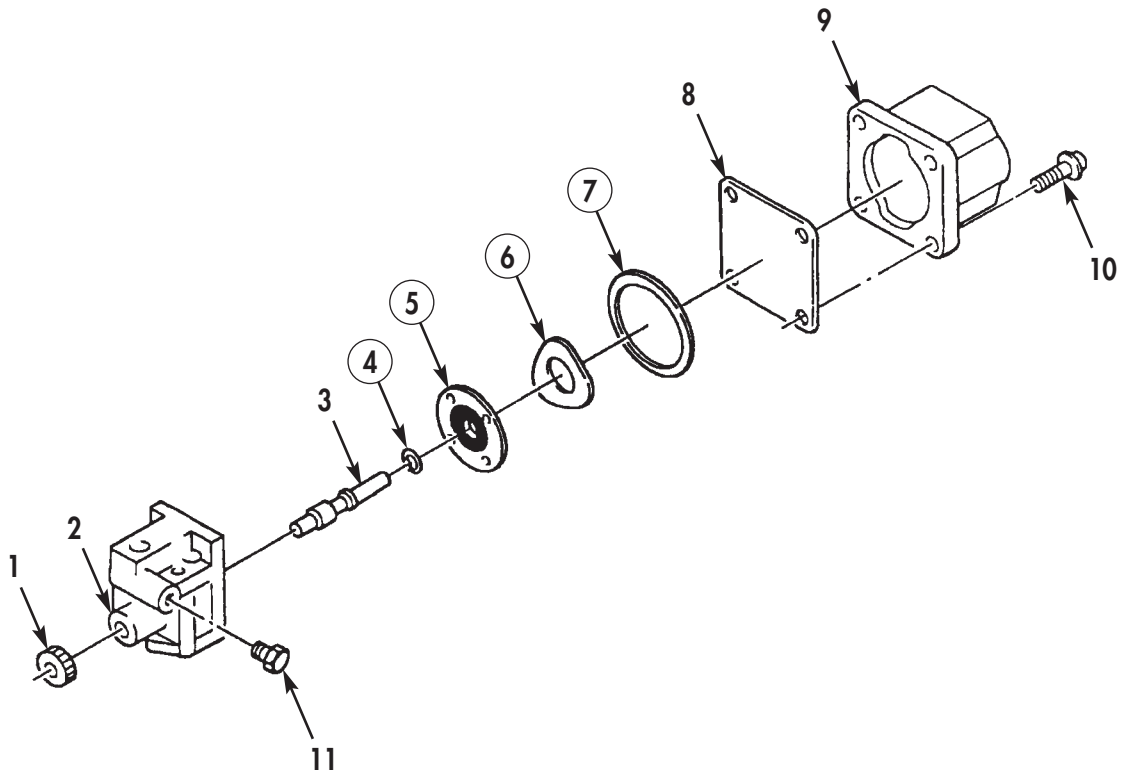


Figure 1. Solenoid Valve Repair.

END OF WORK PACKAGE

**DIRECT SUPPORT AND GENERAL SUPPORT
MAINTENANCE MANUAL
INCLUDING REPAIR PARTS AND SPECIAL TOOLS LIST (RPSTL)**

FOR

M915, M915A1, M915A4, M916, M920 VEHICLES

NSN 2815-01-082-8125	P/N NTC400-3652-02	CUMMINS NTC-400 BIG CAM I DIESEL ENGINE W/CONTAINER
NSN 2815-01-142-2745	P/N 11669835	CUMMINS NTC-400 BIG CAM III DIESEL ENGINE W/CONTAINER

FUEL DAMPER AND HEAD

DISASSEMBLY, CLEANING AND INSPECTION, ASSEMBLY

INITIAL SETUP:

Tools and Special Tools

General mechanic's tool kit: automotive
(Item 1, WP 0061 00)
Maintenance and repair shop equipment:
automotive (Item 2, WP 0061 00)
Automotive maintenance and repair
supplemental set no. 2 (Item 3, WP 0061 00)

Equipment Condition

Fuel damper and head removed from fuel
pump (WP 0033 00).

Material/Parts

Lubricating oil (Item 19, WP 0060 00)
Sealing compound (Item 25, WP 0060 00)
Rectangular ring seal
(Item 1, Table 18, WP 0062 00)
Rectangular ring seal
(Item 2, Table 18, WP 0062 00)
Fuel pump damper diaphragm
(Item 3, Table 18, WP 0062 00)
Nylon washer
(Item 4, Table 18, WP 0062 00)

FUEL DAMPER AND HEAD (Contd)

DISASSEMBLY

1. Remove two screws (1), plate (7), nylon washer (6), rectangular ring seal (5), fuel pump damper diaphragm (4), and rectangular ring seal (3) from filter head (2). Discard rectangular ring seals (3) and (5), fuel pump damper diaphragm (4), and nylon washer (6).
2. Remove pipe plug (8) from filter head (2).

CLEANING AND INSPECTION

1. For general parts cleaning information, refer to CLEANING, WP 0051 00.
2. For general parts inspection information, refer to INSPECTION, WP 0051 00.

NOTE

Replace any part that does not pass visual inspection or that is outside specified wear limits.

3. Inspect filter head (2) and plate (7) for corrosion, excessive wear, and cracks. Discard damaged or worn parts.
4. Inspect filter head (2) for stripped threaded holes or plugged fuel passages. Repair any stripped holes and clean any plugged fuel passages.

ASSEMBLY

1. Apply sealing compound to pipe plug (8) and install on filter head (2).
2. Install new rectangular ring seal (5) and new nylon washer (6) on plate (7).
3. Install new rectangular ring seal (3) on filter head (2).
4. Apply lubricating oil to new fuel pump damper diaphragm (4) on plate (7). Ensure that fuel pump damper diaphragm (4) is clean.
5. Install plate (7) on filter head (2) with two screws (1). Apply sealing compound to pipe plug (8) and tighten screws (1) 11–13 lb-ft (15–18 N·m).
6. For installation of fuel damper and head, refer to WP 0040 00.

FUEL DAMPER AND HEAD (Contd)

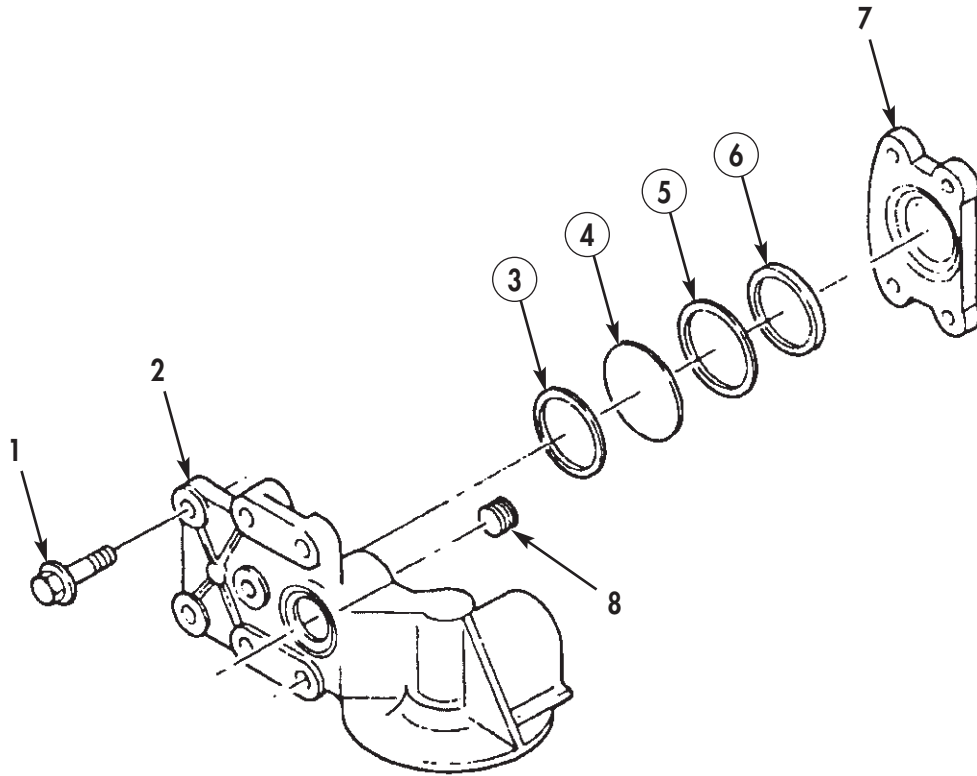


Figure 1. Fuel Damper and Head Repair.

END OF WORK PACKAGE

**DIRECT SUPPORT AND GENERAL SUPPORT
MAINTENANCE MANUAL
INCLUDING REPAIR PARTS AND SPECIAL TOOLS LIST (RPSTL)**

FOR

M915, M915A1, M915A4, M916, M920 VEHICLES

NSN 2815-01-082-8125	P/N NTC400-3652-02	CUMMINS NTC-400 BIG CAM I DIESEL ENGINE W/CONTAINER
NSN 2815-01-142-2745	P/N 11669835	CUMMINS NTC-400 BIG CAM III DIESEL ENGINE W/CONTAINER

FUEL GEAR PUMP

DISASSEMBLY, CLEANING AND INSPECTION, ASSEMBLY

INITIAL SETUP:

Tools and Special Tools

General mechanic's tool kit: automotive
(Item 1, WP 0061 00)
Maintenance and repair shop equipment:
automotive (Item 2, WP 0061 00)
Automotive maintenance and repair
supplemental set no. 2 (Item 3, WP 0061 00)
Pressurizing valve driver
(Item 38, WP 0061 00)
Press

Equipment Condition

Fuel gear pump removed from fuel pump
housing (WP 0033 00).

Material/Parts

Lubricating oil (Item 19, WP 0060 00)
Pipe sealant (Item 25, WP 0060 00)
Two lockwashers
(Item 1, Table 19, WP 0062 00)
Gasket (Item 2, Table 19, WP 0062 00)
Pressure valve (Item 3, Table 19, WP 0062 00)
Two bearing sleeves
(Item 4, Table 19, WP 0062 00)
Dowel ring (Item 5, Table 19, WP 0062 00)

FUEL GEAR PUMP (Contd)

DISASSEMBLY

1. Remove fuel supply elbow (9), adapter (8), and pipe plug (13) from gear body (7).
2. Remove two screws (12), lockwashers (11), washers (10), gear cover (2), and gasket (6) from gear body (7). Discard lockwashers (11) and gasket (6).
3. Remove idler shaft (4) and drive shaft (16) from gear body (7).
4. Using press, remove idler gear (5) from idler shaft (4).
5. Using press, remove drive gear (15) from drive shaft (16).
6. Remove two dowel pins (3), dowel ring (1), pressure valve (17), and two bearing sleeves (14) from gear cover (2). Discard pressure valve (17), bearing sleeves (14), and dowel ring (1).

FUEL GEAR PUMP (Contd)

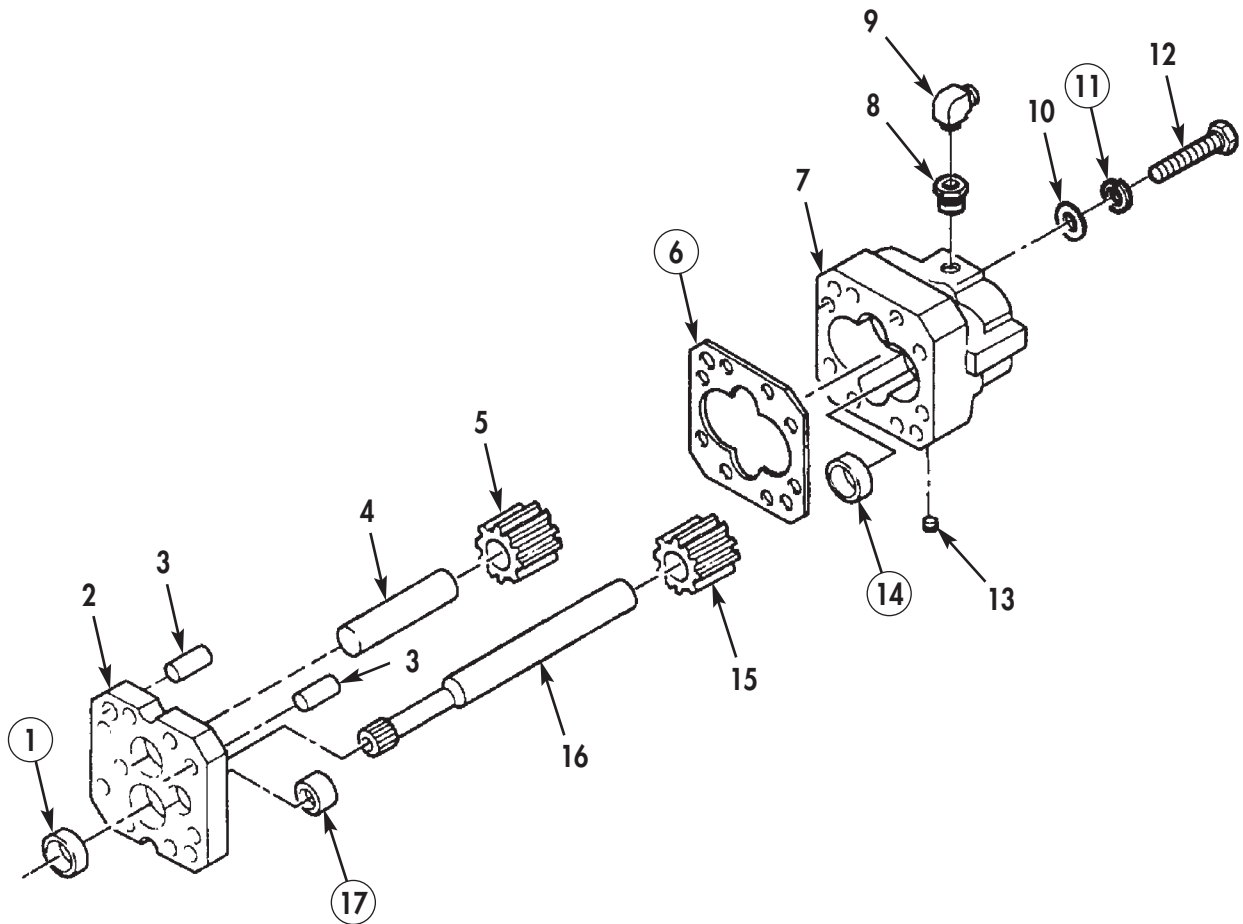


Figure 1. Fuel Gear Pump Disassembly.

FUEL GEAR PUMP (Contd)

CLEANING AND INSPECTION

1. For general parts cleaning information, refer to CLEANING, WP 0051 00.
2. For general parts inspection information, refer to INSPECTION, WP 0051 00.

NOTE

Replace any part that does not pass visual inspection or that is outside specified wear limits.

The fuel supply elbow contains a check ball. Do not replace with a standard elbow.

3. Inspect fuel supply elbow (7), adapter (6), and pipe plug (8) for cracks, chipped or stripped threads.
4. Inspect idler shaft (3) and drive shaft (10) for scoring, bends, or stripped teeth.
5. Using micrometer or equivalent, measure ends of idler shaft (3) outside diameter at center and end of idler shaft (3). Minimum outside diameter is 0.499 in. (12.70 mm).
6. Using micrometer or equivalent, measure drive shaft (10) outside diameter at end and center of drive shaft (10). Minimum outside diameter is 0.499 in. (12.70 mm).
7. Inspect idler gear (4) and drive gear (9) for chips, cracks, and stripped teeth.
8. Using micrometer or equivalent, measure idler gear (4) and drive gear (9) length. Idler gear (4) and drive gear (9) length should be 0.7483–0.7486 in. (19.007–19.014 mm).
9. Inspect gear body (5) and gear cover (1) for scoring, cracks, or stripped threaded holes.
10. Using depth micrometer, measure gear body (5) depth. Gear body depth should be 0.7478–0.7481 in. (18.994–19.002 mm).
11. Using telescoping gauge and micrometer, measure gear body (5) and gear cover (1) shaft bores inside diameter. Inside diameter should be 0.5011–0.5016 in. (12.728–12.741 mm).
12. Inspect dowel pins (2) for cracks, chips, or bends.

FUEL GEAR PUMP (Contd)

0.7483-0.7486 in. (19.007-19.014 mm)

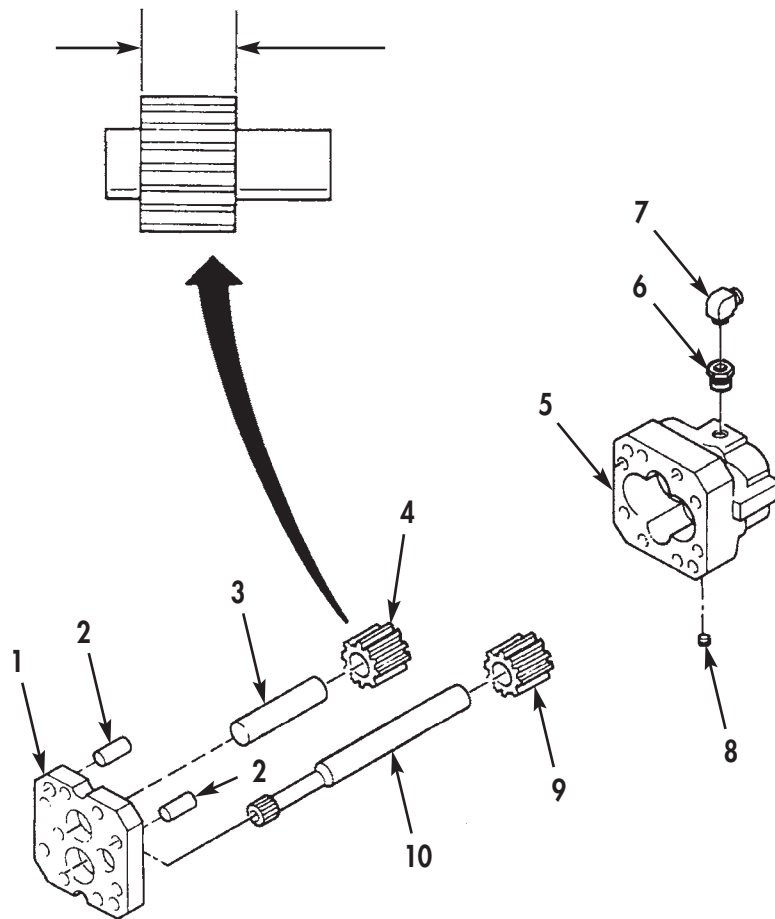


Figure 2. Fuel Pump Cleaning and Inspection.

FUEL GEAR PUMP (Contd)

ASSEMBLY

NOTE

Lubricate all parts, seals, seal rings, and O-rings with lubricating oil before installation.

1. Using press, install two new bearing sleeves (15) in gear body (7).
2. Using press, install two new bearing sleeves (15) and new dowel ring (1) in gear cover (2).
3. Using pressurizing valve driver, install new pressure valve (18) 0.015 in. (0.381 mm) below face of gear cover (2).
4. Install two dowel pins (3) in gear cover (2).
5. Using press, install drive gear (16) on drive shaft (17) 0.680–0.690 in. (17.272–17.526 mm) from end of drive shaft (17).
6. Using press, install idler gear (5) on idler shaft (4) 0.680–0.690 in. (17.272–17.526 mm) from end of idler shaft (4).
7. Install idler shaft (4) with idler gear (5) attached and drive shaft (17) with drive gear (16) attached in gear cover (2).

NOTE

Location of notches or ridges on gear body and gear cover determine pump rotation.

When a right-hand rotation pump is being assembled, place driven gear shaft of gear pump in pocket nearest locating notches or ridges. Place driving gear shaft in other pocket. The dowel ring is always located around drive shaft.

8. Align notches in gear cover (2) with notches on gear body (7) and install new gasket (6) and gear cover (2) on gear body (7) with two screws (12), new lockwashers (11), and washers (10). Tighten screw (12) 11–13 lb-ft (15–18 N•m).
9. Apply pipe sealant to pipe plug (14) and install in gear body (7). Tighten pipe plug (14) 10–13 lb-ft (14–18 N•m).
10. Install adapter (8) and fuel supply elbow (9) on gear body (7).
11. Using dial indicator, measure drive shaft (17) backlash. Backlash should be 0.001–0.004 in. (0.0254–0.1016 mm). If correct backlash cannot be obtained, disassemble fuel gear pump (13) and replace idler gear (5) and drive shaft gear (16).
12. Using dial indicator, measure drive shaft (17) end play. End play should be between 0.0009–0.0015 in. (0.0228–0.038 mm). If correct end play cannot be obtained, disassemble fuel gear pump (13) and replace gear body (7) and drive shaft (17).
13. Install fuel gear pump (13) on fuel pump housing. Refer to WP 0040 00.

FUEL GEAR PUMP (Contd)

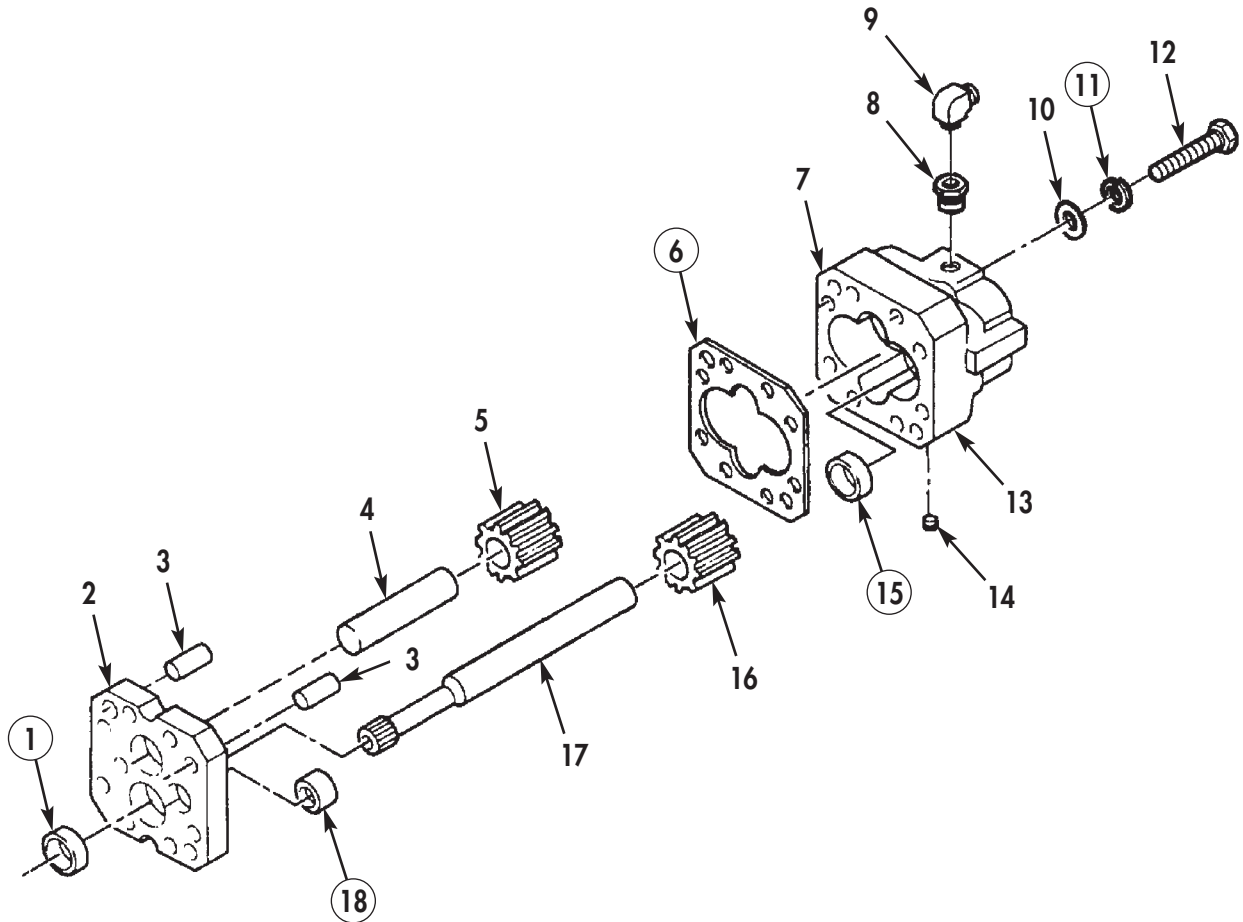


Figure 3. Fuel Gear Pump Assembly.

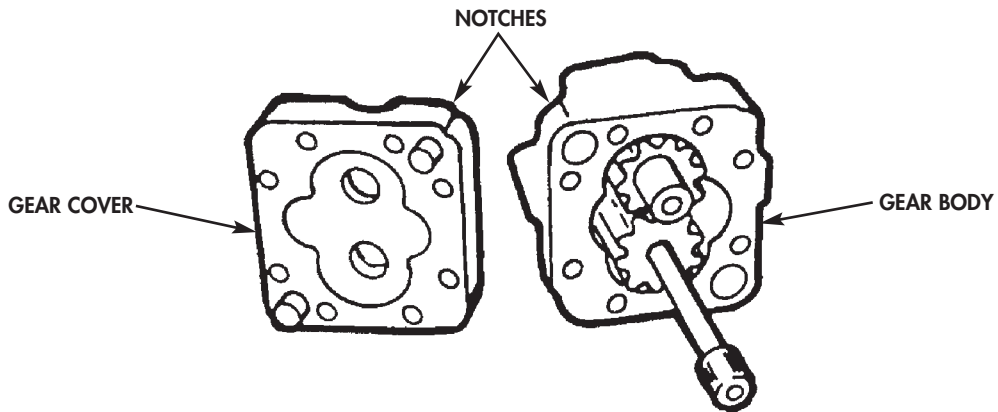


Figure 4. Fuel Gear Body and Gear Cover.

END OF WORK PACKAGE

**DIRECT SUPPORT AND GENERAL SUPPORT
MAINTENANCE MANUAL
INCLUDING REPAIR PARTS AND SPECIAL TOOLS LIST (RPSTL)**

FOR

M915, M915A1, M915A4, M916, M920 VEHICLES

NSN 2815-01-082-8125	P/N NTC400-3652-02	CUMMINS NTC-400 BIG CAM I DIESEL ENGINE W/CONTAINER
NSN 2815-01-142-2745	P/N 11669835	CUMMINS NTC-400 BIG CAM III DIESEL ENGINE W/CONTAINER

**FUEL PUMP GOVERNOR SPRING
DISASSEMBLY, CLEANING AND INSPECTION, ASSEMBLY**

INITIAL SETUP:

Tools and Special Tools

General mechanic's tool kit:
 automotive (Item 1, WP 0061 00)
Maintenance and repair shop equipment:
 automotive (Item 2, WP 0061 00)
Automotive maintenance and repair
 supplemental set no. 2 (Item 3, WP 0061 00)

Equipment Condition

Fuel pump governor spring removed from fuel
pump (WP 0033 00).

Material/Parts

Lubricating oil (Item 19, WP 0060 00)
Idling spring (Item 1, Table 20, WP 0062 00)
Compression spring
 (Item 2, Table 20, WP 0062 00)
Lead seal

FUEL PUMP GOVERNOR SPRING (Contd)

DISASSEMBLY

NOTE

Do not discard shim.

1. Remove spring retainer (7), shim (8), and compression spring (9) from guide (5). Discard compression spring (9).

NOTE

Lead seal is used on Big Cam I only.

2. Remove idle adjusting screw (6), lead seal (1), idle spring plunger (2), idling spring (3), and adjusting screw washer (4) from guide (5). Discard lead seal (1) and idling spring (3).

CLEANING AND INSPECTION

1. For general parts cleaning information, refer to CLEANING, WP 0051 00.
2. For general parts inspection information, refer to INSPECTION, WP 0051 00.

NOTE

Replace any part that does not pass visual inspection or that is outside specified wear limits.

3. Inspect guide (5) and idle adjusting screw (6) for crossthreading, stripped threads, and other damage.

ASSEMBLY

NOTE

Lubricate all parts, seals, seal rings, and O-rings with lubricating oil before installation.

1. Install idle adjusting screw (6) in guide (5).

NOTE

Lead seal is required for Big Cam I only.

2. Install adjusting screw washer (4), new idling spring (3), idle spring plunger (2), and new lead seal (1) on idle adjusting screw (6).

NOTE

Final number of shims is determined at calibration.

3. Install new compression spring (9), shim (8), and spring retainer (7) on guide (5).
4. Install fuel pump governor spring (WP 0040 00).

FUEL PUMP GOVERNOR SPRING (Contd)

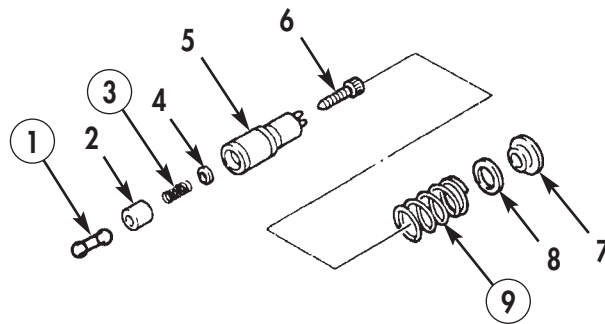


Figure 1. Fuel Pump Governor Spring Disassembly, Cleaning and Inspection, and Assembly.

**DIRECT SUPPORT AND GENERAL SUPPORT
MAINTENANCE MANUAL
INCLUDING REPAIR PARTS AND SPECIAL TOOLS LIST (RPSTL)**

FOR

M915, M915A1, M915A4, M916, M920 VEHICLES

NSN 2815-01-082-8125	P/N NTC400-3652-02	CUMMINS NTC-400 BIG CAM I DIESEL ENGINE W/CONTAINER
NSN 2815-01-142-2745	P/N 11669835	CUMMINS NTC-400 BIG CAM III DIESEL ENGINE W/CONTAINER

**FUEL PUMP FRONT COVER AND GOVERNOR
DISASSEMBLY, CLEANING AND INSPECTION, ASSEMBLY**

INITIAL SETUP:

Tools and Special Tools

General mechanic's tool kit: automotive
(Item 1, WP 0061 00)
Maintenance and repair shop equipment:
automotive (Item 2, WP 0061 00)
Automotive maintenance and repair
supplemental set no. 2 (Item 3, WP 0061 00)
Press
Main shaft seal driver (Item 20, WP 0061 00)
Front cover tachometer seal driver
(Item 21, WP 0061 00)
Main shaft gear and bearing installation tool
(Item 22, WP 0061 00)
Oil seal assembly tool (Item 23, WP 0061 00)
Plunger protrusion checking tool
(Item 24, WP 0061 00)

Equipment Condition

Fuel pump front cover and governor removed
from fuel pump (WP 0033 00).

Material/Parts

Lubricating oil (Item 19, WP 0060 00)
Spring (Item 1, Table 21, WP 0062 00)
Retaining ring (Item 2, Table 21, WP 0062 00)
Bearing (Item 3, Table 21, WP 0062 00)
Two shaft seals (Item 4, Table 21, WP 0062 00)
Seal (Item 5, Table 21, WP 0062 00)
Bushing (Item 6, Table 21, WP 0062 00)
Governor bushing
(Item 7, Table 21, WP 0062 00)

FUEL PUMP FRONT COVER AND GOVERNOR (Contd)

DISASSEMBLY

NOTE

Be careful not to lose spring and shims during removal of weight-assist plunger. Keep weight-assist plunger, shims, and spring together.

1. Remove weight-assist plunger (13), shims (12), and spring (11) from governor (14). Discard spring (11).
2. Remove screw (20) and washer (21) securing fuel pump drive coupling (22) on fuel pump drive shaft (24).
3. Using puller, remove fuel pump drive coupling (22), tachometer drive gear (23), and coupling key (19) from fuel pump drive shaft (24).
4. Remove retaining ring (8) securing fuel pump drive shaft (24) in fuel pump front cover (16). Discard retaining ring (8).
5. Remove fuel pump drive shaft (24), with bearing (7), fuel pump drive gear (9), and coupling (10) attached, from fuel pump front cover (16).
6. Using press, remove coupling (10) and fuel pump drive gear (9) from fuel pump drive shaft (24).
7. Using press, remove bearing (7) from fuel pump drive shaft (24). Discard bearing (7).
8. Remove tachometer drive housing (2) from fuel pump front cover (16).
9. Using brass punch and hammer, remove tachometer drive shaft (1), with seal (3), spacer (4), bushing (5), and gear (6) attached, from fuel pump front cover (16).
10. Remove gear (6), bushing (5), spacer (4), and seal (3) from tachometer drive shaft (1). Discard seal (3) and bushing (5).
11. Using press, remove two shaft seals (17) and (18) from fuel pump front cover (16). Discard shaft seals (17) and (18).
12. Using brass punch and hammer, remove governor bushing (15) from fuel pump front cover (16). Discard governor bushing (15).

CLEANING AND INSPECTION

1. For general parts cleaning information, refer to CLEANING, WP 0051 00.
2. For general parts inspection information, refer to INSPECTION, WP 0051 00.

NOTE

Replace any part that does not pass visual inspection or that is outside specified wear limits.

3. Inspect weight-assist plunger (13), governor (14), fuel pump drive coupling (22), tachometer drive gear (23), fuel pump drive shaft (24), fuel pump drive gear (9), coupling (10), tachometer drive housing (2), gear (6), tachometer drive shaft (1), and fuel pump front cover (16) for cracks, breaks, excessive wear, and other damage.
4. Inspect fuel pump drive shaft (24) and tachometer drive shaft (1) for scoring, wear, grooves, and other damage.

FUEL PUMP FRONT COVER AND GOVERNOR (Contd)

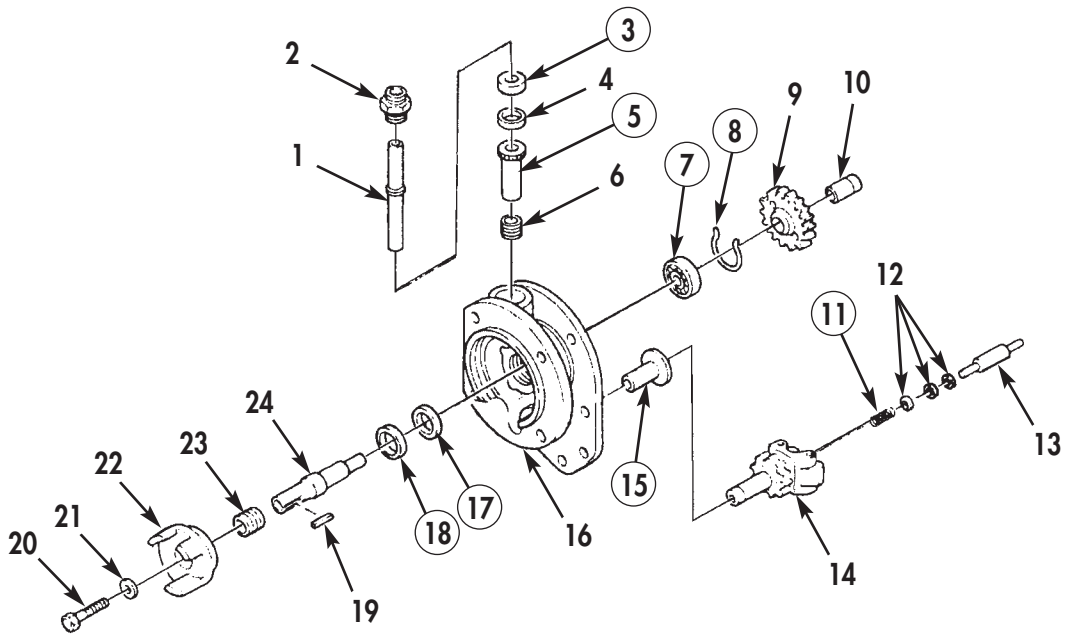


Figure 1. Fuel Pump Front Cover and Governor Disassembly, Cleaning, and Inspection.

FUEL PUMP FRONT COVER AND GOVERNOR (Contd)

ASSEMBLY

NOTE

Lubricate all parts, seals, seal rings, and O-rings with lubricating oil before installation.

1. Install new bushing (5) on tachometer drive shaft (1).
2. Using press, install gear (6) on tachometer drive shaft (1) until 0.002–0.005-in. (0.050–0.127-mm) gap between bushing (5) and gear (6) is obtained. Using a feeler gauge, check clearance between gear (6) and bushing (5). Remove and install gear (6) until correct gear (6) to bushing (5) clearance is obtained.
3. Align oil groove in top of bushing (5) with fuel pump drive shaft (1). Using press, install bushing (5) with tachometer drive shaft (1) and gear (6) attached on fuel pump front cover (16) until fully seated.
4. Install spacer (4) on tachometer drive shaft (1) with slotted edge facing down until seated against top of bushing (5).
5. Using front cover tachometer seal driver and hammer, install new seal (3) with spring side down in fuel pump front cover (16).
6. Install tachometer drive housing (2) in fuel pump front cover (16).

CAUTION

Do not overtighten tachometer drive housing because it will compress spacer too much and will reduce its effectiveness.

7. Lubricate fuel pump drive shaft (24) with clean diesel fuel. Using main shaft gear and bearing installation tool and press, install new bearing (7) on fuel pump drive shaft (24).
8. Using main shaft gear and bearing installation tool and press, install fuel pump drive gear (9) on fuel pump drive shaft (24) until fully seated on bearing (7).
9. Apply lubricating oil to fuel pump drive shaft (24) and bore of coupling (10). Using press, install coupling (10) on fuel pump drive shaft (24) until fully seated against fuel pump drive gear (9).
10. Using main shaft seal driver and press, install first new shaft seal (17) in fuel pump front cover (16) with lip facing back of fuel pump front cover (16).
11. Using main shaft seal driver and press, install second new shaft seal (18) on fuel pump front cover (16) with lip facing front of fuel pump front cover (16).
12. Using oil seal assembly tool and press, install fuel pump drive shaft (24) with bearing (7) and gear (9) attached in fuel pump front cover (16) until bearing (7) is fully seated. Ensure first shaft seal (17) and second shaft seal (18) are not moved during assembly.
13. Install new retaining ring (8) on fuel pump drive shaft (24) between fuel pump drive gear (9) and bearing (7). Look through holes in fuel pump drive gear (9) to ensure retaining ring (8) is properly seated in groove.
14. Install coupling key (19) in fuel pump drive shaft (24).
15. Position tachometer drive gear (23) and fuel pump drive coupling (22) on fuel pump drive shaft (24). Using press, slowly install tachometer drive gear (23) and fuel pump drive coupling (22) on fuel pump drive shaft (24) until fully seated. Ensure tachometer drive gear (23) and tachometer gear teeth are properly aligned.
16. Install screw (20) and washer (21) in fuel pump drive shaft (24). Tighten screw (20) 5 lb-ft (7 N•m).
17. Using press, install new governor bushing (15) in fuel pump front cover (16).

FUEL PUMP FRONT COVER AND GOVERNOR (Contd)**ASSEMBLY (Contd)**

18. Install governor (14) in governor bushing (15) and rotate governor (14) until weights are open.
19. Install weight-assist plunger (13) with small end facing governor weights. Install shims (12) and new spring (11) in bore of governor (14).
20. Using plunger protrusion checking tool and dial indicator, measure protrusion of weight-assist plunger (13). Weight-assist plunger (13) protrusion should be 0.800 in. (20.32 mm). If weight-assist plunger (13) protrusion is less than 0.800 in. (20.32 mm), add shims (12). If weight-assist plunger (13) protrusion is more than 0.800 in. (20.32 mm), remove shims (12) or grind end of weight-assist plunger (13). Repeat procedure until weight-assist plunger (13) protrusion is correct.
21. Install fuel pump front cover and governor (Refer to WP 0040 00).

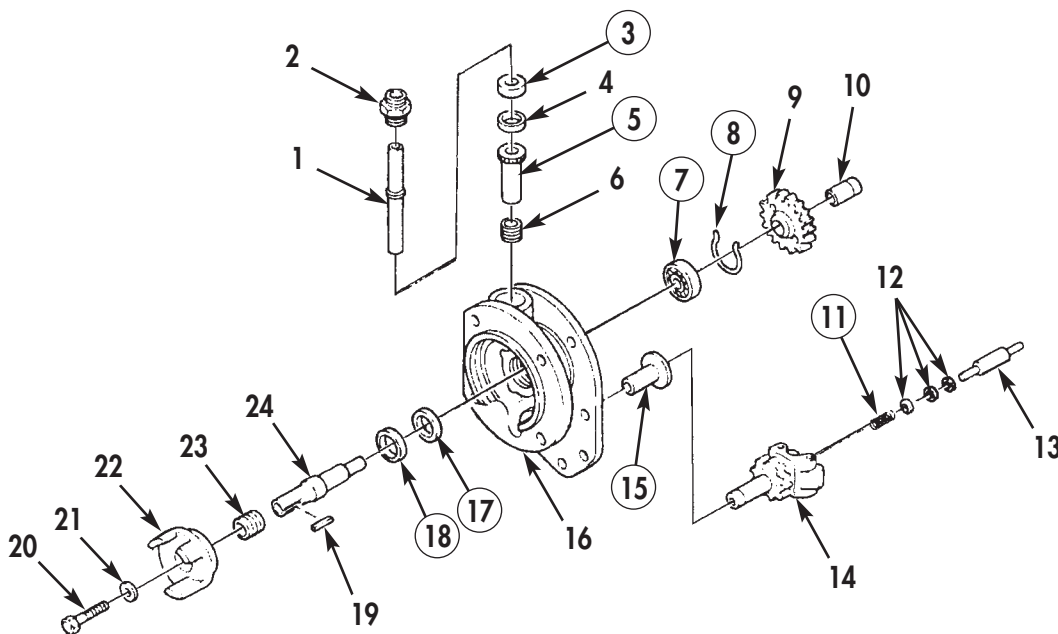


Figure 2. Fuel Pump Front Cover and Governor Assembly.

END OF WORK PACKAGE

0038 00-5/6 blank

**DIRECT SUPPORT AND GENERAL SUPPORT
MAINTENANCE MANUAL
INCLUDING REPAIR PARTS AND SPECIAL TOOLS LIST (RPSTL)**

FOR

M915, M915A1, M915A4, M916, M920 VEHICLES

NSN 2815-01-082-8125	P/N NTC400-3652-02	CUMMINS NTC-400 BIG CAM I DIESEL ENGINE W/CONTAINER
NSN 2815-01-142-2745	P/N 11669835	CUMMINS NTC-400 BIG CAM III DIESEL ENGINE W/CONTAINER

FUEL PUMP MAIN HOUSING

DISASSEMBLY, CLEANING AND INSPECTION, ASSEMBLY

INITIAL SETUP:

Tools and Special Tools

General mechanic's tool kit: automotive
(Item 1, WP 0061 00)
Maintenance and repair shop equipment:
automotive (Item 2, WP 0061 00)
Automotive maintenance and repair
supplemental set no. 2 (Item 3, WP 0061 00)
Press
AFC barrel puller (Item 69, WP 0061 00)

Equipment Condition

Fuel pump main housing removed from fuel
pump (WP 0033 00).

Material/Parts

Lubricating oil (Item 19, WP 0060 00)
Retaining ring (Item 1, Table 22, WP 0062 00)
O-ring (Item 2, Table 22, WP 0062 00)
Throttle shaft ball
(Item 3, Table 22, WP 0062 00)
O-ring (Item 4, Table 22, WP 0062 00)
O-ring (Item 5, Table 22, WP 0062 00)
Cap seal ring (Item 6, Table 22, WP 0062 00)
Retaining ring (Item 7, Table 22, WP 0062 00)
O-ring (Item 8, Table 22, WP 0062 00)
O-ring (Item 9, Table 22, WP 0062 00)
O-ring (Item 10, Table 22, WP 0062 00)
O-ring (Item 11, Table 22, WP 0062 00)
Gasket washer
(Item 12, Table 22, WP 0062 00)
Bellows (Item 13, Table 22, WP 0062 00)

FUEL PUMP MAIN HOUSING (Contd)

DISASSEMBLY

1. Remove two drive screws (19) from throttle shaft cover (18).
2. Remove retaining ring (33) from throttle shaft (22). Discard retaining ring (33).
3. Remove throttle shaft (22) and O-ring (23) from housing (9). Discard O-ring (23).
4. Remove throttle shaft ball (17) from throttle shaft (22). Discard throttle shaft ball (17).
5. Remove fuel adjusting screw (20) and O-ring (16) from throttle shaft (22). Discard O-ring (16).
6. Remove setscrew (15) and throttle shaft (22) from stop (21).
7. Loosen nut (14) from Air Fuel Control (AFC) needle valve (12).
8. Remove AFC needle valve (12) and O-ring (13) from housing (9). Discard O-ring (13).
9. Remove nut (14) from AFC needle valve (12).
10. Remove threaded stud (11) secured with jamnut (10) from housing (9).
11. Remove jamnut (10) securing tapered stud (31) from housing (9).
12. Remove filter screen cap (5), cap seal ring (6), filter spring (7), and fuel filter screen (8) from housing (9). Discard cap seal ring (6).
13. Remove check valve (39) from fuel control cover (40).
14. Remove two screws (38), drilled head screw (37), and three washers (36) from fuel control cover (40).
15. Move bellows (45) away from sealing surface on housing (9) and remove with attached parts.
16. Remove spring (58), AFC shim (57), and retaining ring (56) from housing (9). Discard retaining ring (56).

NOTE

Heat governor housing in oven to 300° F (149° C) to prevent damage to housing bore during barrel removal.

17. Using AFC barrel puller, remove barrel (52), and three O-rings (53), (54), and (55) from housing (9). Discard O-rings (53), (54), and (55).
18. Remove barrel spring (51) from housing (9).

NOTE

Earlier pump models did not require a barrel spring.

19. Remove jamnut (41) from throttle plunger (50).
20. Remove throttle plunger (50) and O-ring (49) from air fuel control piston insert (42). Discard O-ring (49).
21. Remove nut (48) securing air fuel control piston insert (42) and remove piston spacer (47), AFC piston (46), bellows (45), retainer washer (44), and gasket washer (41) from air fuel control piston insert (42). Discard gasket washer (43) and bellows (45).
22. Remove governor plunger (30), three shims (29), and torque spring (28) from housing (9).
23. Remove torque spring (28) and three shims (29) from governor plunger (30).
24. Remove five pipe plugs (1) and (4) and roll pin (24) from housing (9).
25. Remove spring pack (27) and governor barrel (26) from housing (9).
26. Remove tachometer drive bushing (32), two AFC plug balls (34), and two dowels (25) and (35) from housing (9).
27. Remove two screws (3) and nameplate (2) from housing (9).

FUEL PUMP MAIN HOUSING (Contd)

CLEANING AND INSPECTION

1. For general parts cleaning information, refer to CLEANING, WP 0051 00.
2. For general parts inspection information, refer to INSPECTION, WP 0051 00.

NOTE

Replace any part that does not pass visual inspection or that is outside specified wear limits.

3. Inspect tachometer drive bushing (32) for scoring, burrs, and other damage.
4. Using vernier caliper, measure inside diameter of tachometer drive bushing (32). Maximum inside diameter is 0.752 in. (19.10 mm).
5. Inspect governor barrel (26) for scoring, burrs, and other damage.
6. Using outside micrometer, measure governor barrel (26) diameter of bore in housing (9) and outside diameter of governor barrel (26). Diameter of bore should be 0.002 in. (0.051 mm) smaller than governor barrel (26) outside diameter.
7. Inspect governor plunger (30), and shims (29) for scoring, burrs, and other damage.
8. Inspect housing (1) and nameplate (2) for scoring, burrs, and other damage.
9. Inspect fuel filter screen (8) for holes and embedded metal particles in mesh.
10. Inspect dowels (25) and (35) for damage.

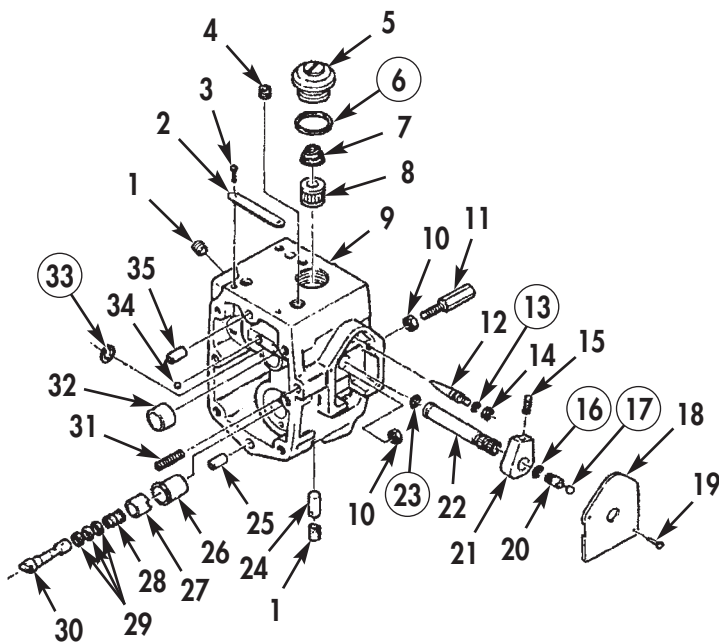


Figure 1. Main Housing Disassembly.

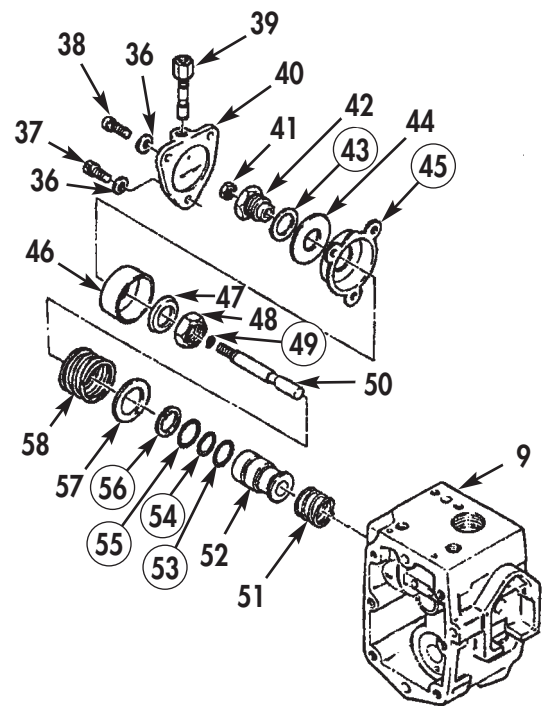


Figure 2. Main Housing Disassembly.

FUEL PUMP MAIN HOUSING (Contd)

ASSEMBLY

NOTE

Lubricate all parts, seals, seal rings, and O-rings with lubricating oil before installation.

1. Install two screws (3) and nameplate (2) on housing (9).
2. Install two dowels (25) and (35), two AFC plug balls (34), and tachometer drive bushing (32) on housing (9).
3. Install governor barrel (26) and spring pack (27) on housing (9).
4. Install five pipe plugs (1) and (4), and roll pin (24) on housing (9). Tighten pipe plugs (1) and (4) 5–8 lb-ft (7–11 N•m).

NOTE

Put small diameter of spring on shoulder end of plunger with twisting motion to avoid damaging spring.

5. Install torque spring (28) and three shims (29) on governor plunger (30).
6. Install governor plunger (30) on housing (9).

NOTE

Round end of retainer washer must be against bellows when assembled. If bellows has a part number, it must face toward piston.

Ensure all parts are aligned and do not twist bellows.

7. Install new gasket washer (43), retainer washer (44), new bellows (45), AFC piston (46), piston spacer (47), and nut (48) on air fuel control piston insert (42). Tighten nut (48) 30–40 lb-ft (41–54 N•m).
8. Apply lubricating oil to new O-ring (49) and install throttle plunger (50) on air fuel control piston insert (42). Ensure that threaded end of throttle plunger (50) is flush with outer edge of piston insert (42).
9. Tighten jamnut (41) on throttle plunger (50) until finger-tight.

NOTE

Earlier pump models did not require a barrel spring.

10. Install barrel spring (51) in housing (9).
11. Apply lubricating oil to three new O-rings (53), (54), and (55) and install O-rings (53), (54), and (55) with spring (50) on barrel (52).
12. Using press, install barrel (52) in housing (9) and secure with new retaining ring (56).
13. Apply 10 lb (4.54 kg) of load on spring (58) and AFC shim (57).
14. Compress spring 0.300 in. (7.62 mm) more than dimension of step 13 and install AFC shim (57) and spring (58) on housing (9).
15. Install bellows (45) down between AFC piston (46) and housing (9) and line up holes in bellows (45) with holes in housing (9). Ensure bellows (45) is flat where it touches housing (9).
16. Install fuel control cover (40) on bellows (45) and housing (9) with two screws (38), drilled head screw (37), and three washers (36). Do not tighten screws (38).
17. Ensure check ball is loose and hole near bottom of check valve (39) is not plugged. Turn check valve (39) on top of fuel control cover (40). Tighten fuel control cover (40) 5 lb-ft (7 N•m).

FUEL PUMP MAIN HOUSING (Contd)

ASSEMBLY (Contd)

18. Install fuel filter screen (8), filter spring (7), new cap seal ring (6), and filter screen cap (5) on housing (9). Tighten filter screen cap (5) 8–12 lb-ft (11–16 N•m).
19. Install tapered stud (31) with jamnut (10) and threaded stud (11) on housing (9).
20. Apply lubricating oil to new O-ring (13) and install AFC needle valve (12) on housing (9) until AFC needle valve (12) bottoms out.
21. Install throttle shaft (22) on stop (21) and secure with setscrew (15). Do not tighten setscrew (15) at this time.
22. Apply lubricating oil to new O-ring (16) securing fuel adjusting screw (20), and install O-ring (16) on throttle shaft (22) about six rotations. Ensure fuel hole in throttle shaft (22) is open.
23. Apply lubricating oil to new O-ring (23) and install throttle shaft (22) in housing (9) with counterbore of fuel port facing down. Ensure setscrew (15) in stop (21) faces upward. Tighten setscrew (15) 7–9 lb-ft (9–12 N•m).

NOTE

New throttle shaft ball, throttle shaft cover, and two drive screws will be installed after fuel pump has been calibrated.

24. Install new retaining ring (33) on end of throttle shaft (22).
25. Install fuel pump main housing to fuel pump (WP 0040 00).

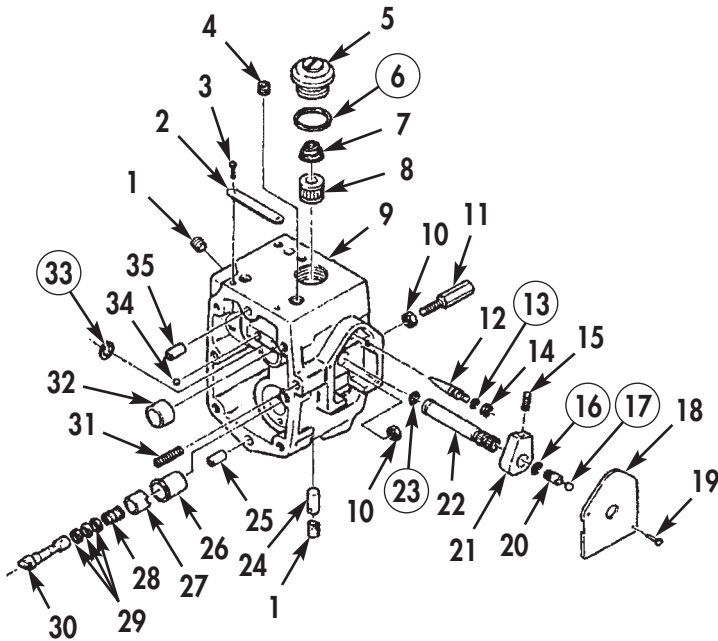


Figure 3. Main Housing Assembly.

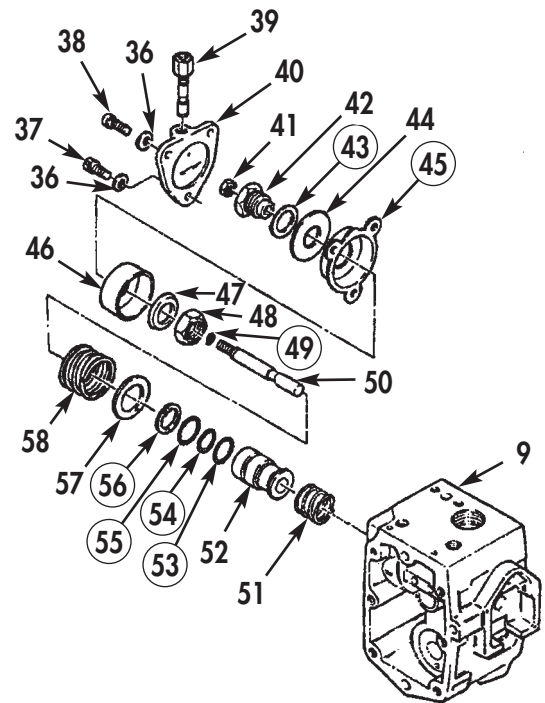


Figure 4. Main Housing Assembly.

END OF WORK PACKAGE

**DIRECT SUPPORT AND GENERAL SUPPORT
MAINTENANCE MANUAL
INCLUDING REPAIR PARTS AND SPECIAL TOOLS LIST (RPSTL)**

FOR

M915, M915A1, M915A4, M916, M920 VEHICLES

NSN 2815-01-082-8125	P/N NTC400-3652-02	CUMMINS NTC-400 BIG CAM I DIESEL ENGINE W/CONTAINER
NSN 2815-01-142-2745	P/N 11669835	CUMMINS NTC-400 BIG CAM III DIESEL ENGINE W/CONTAINER

FUEL PUMP ASSEMBLY

FUEL PUMP FRONT COVER AND GOVERNOR, FUEL PUMP GOVERNOR SPRING, FUEL GEAR PUMP, FUEL DAMPER AND HEAD, SOLENOID VALVE

INITIAL SETUP:

Tools and Special Tools

General mechanic's tool kit: automotive
(Item 1, WP 0061 00)
Maintenance and repair shop equipment:
automotive (Item 2, WP 0061 00)
Automotive maintenance and repair
supplemental set no. 2 (Item 3, WP 0061 00)
Ball joint vise (Item 9, WP 0061 00)
Fuel pump mounting plate
(Item 10, WP 0061 00)

Material/Parts (Contd)

Gasket (Item 10, Table 23, WP 0062 00)
Plastic bushing seal
(Item 11, Table 23, WP 0062 00)
Lubricating oil (Item 19, WP 0060 00)

Equipment Condition

Fuel pump removed from engine
(WP 0010 00)

Material/Parts

Gasket (Item 1, Table 23, WP 0062 00)
Two lockwashers
(Item 2, Table 23, WP 0062 00)
Four lockwashers
(Item 3, Table 23, WP 0062 00)
Four lockwashers
(Item 4, Table 23, WP 0062 00)
Two rectangular seals
(Item 5, Table 23, WP 0062 00)
Rectangular ring seal
(Item 6, Table 23, WP 0062 00)
Eight lockwashers
(Item 7, Table 23, WP 0062 00)
Gasket (Item 8, Table 23, WP 0062 00)
Adjusting screw seal
(Item 9, Table 23, WP 0062 00)

FUEL PUMP ASSEMBLY (Contd)

FUEL PUMP FRONT COVER AND GOVERNOR

NOTE

Position governor weight housing carrier horizontally and hold governor weights while installing fuel pump main housing. Ensure governor weights are properly engaged with tang on governor plunger.

1. Remove fuel pump front cover (3) from mounting plate and ball joint vise.
2. Install new gasket (4), fuel pump (5), and screw (6) on fuel pump front cover (3). Tighten screws (6) 9–11 lb-ft (12–15 N•m).
3. Install six washers (7), eight new lockwashers (8), and screws (9) securing fuel pump front cover (3) on fuel pump (5). Tighten screw (9) 9–11 lb-ft (12–15 N•m).
4. Install new plastic bushing seal (2) and screw (1) on fuel pump front cover (3). Tighten screw (1) 9–11 lb-ft (12–15 N•m).
5. For fuel pump front cover and governor repair, refer to WP 0038 00.

FUEL PUMP GOVERNOR SPRING

1. Install fuel pump governor spring (13), snapping (17), shims (14) and (15) and spring seat (16), on guide (12).
2. Install new gasket (18), spring pack cover (19), four washers (20), and screws (21) on fuel pump (5). Place screw (21) with lockwire hole in upper right corner of spring pack cover (19). Torque screws (21) 9–11 lb-ft (12–15 N•m).

NOTE

Final calibration and on-engine fuel pump adjustments must be made prior to installation of new adjusting screw seal and wire.

3. Install new adjusting screw seal (11) and wire (10) on cover plug (22).
4. For fuel pump governor spring repair, refer to WP 0037 00.

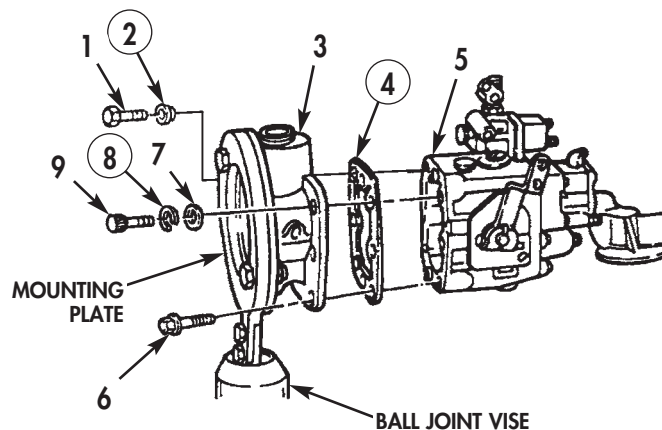


Figure 1. Fuel Pump Front Cover and Governor Installation.

FUEL PUMP ASSEMBLY (Contd)

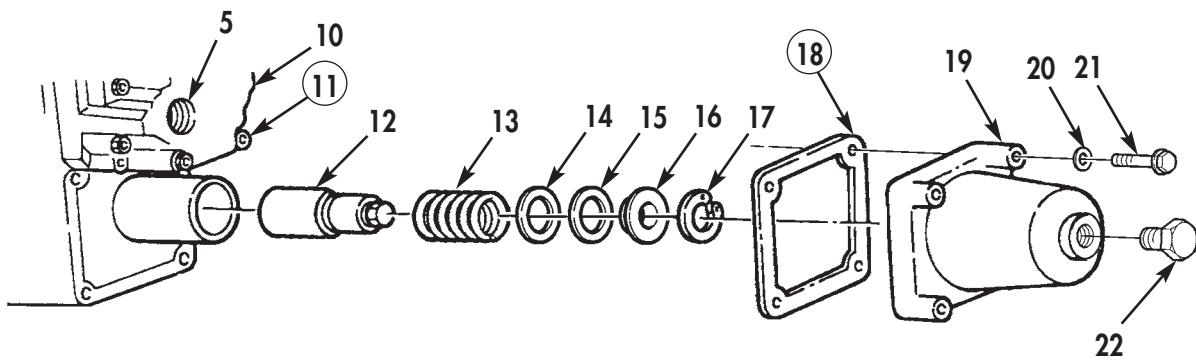


Figure 2. Fuel Pump Governor Spring Installation.

FUEL PUMP ASSEMBLY (Contd)

FUEL GEAR PUMP

NOTE

Use correct gasket in step 2 and ensure that it is positioned correctly. Ensure main housing fuel holes match gear pump holes.

1. Install fuel supply elbow (3) and adapter (4) on gear body (2).
2. Position notch in upper right-hand corner and install fuel gear pump (7) and new gasket (1) on fuel pump (8). Secure with four screws (6) and new lockwashers (5). Tighten screws (6) 11–13 lb-ft (15–18 N•m).

NOTE

Check that gear pump shaft rotates freely.

3. For fuel gear pump repair, refer to WP 0036 00.

FUEL DAMPER AND HEAD

1. Apply light coat of lubricating oil on new rectangular seals (9) and (14) on filter head (10).
2. Install filter head (10) on fuel pump (8) and secure with four screws (13), new lockwashers (12), and washers (11). Tighten screws (13) 11–13 lb-ft (15–18 N•m).
3. For fuel damper and head repair, refer to WP 0035 00.

SOLENOID VALVE

1. Apply light coat of lubricating oil on new rectangular ring seal (21) on solenoid valve (20).
2. Install solenoid valve (20) on fuel pump (8) and secure with two screws (18), new lockwashers (17), and washers (19).
3. Install plug (16) on valve body (15).
4. For solenoid valve repair, refer to WP 0034 00.

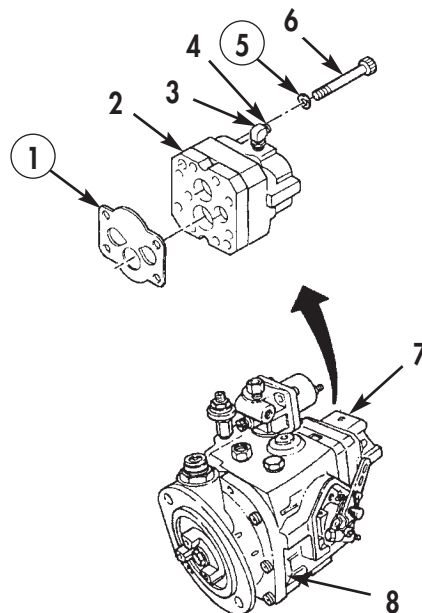


Figure 3. Fuel Gear Pump Installation.

FUEL PUMP ASSEMBLY (Contd)

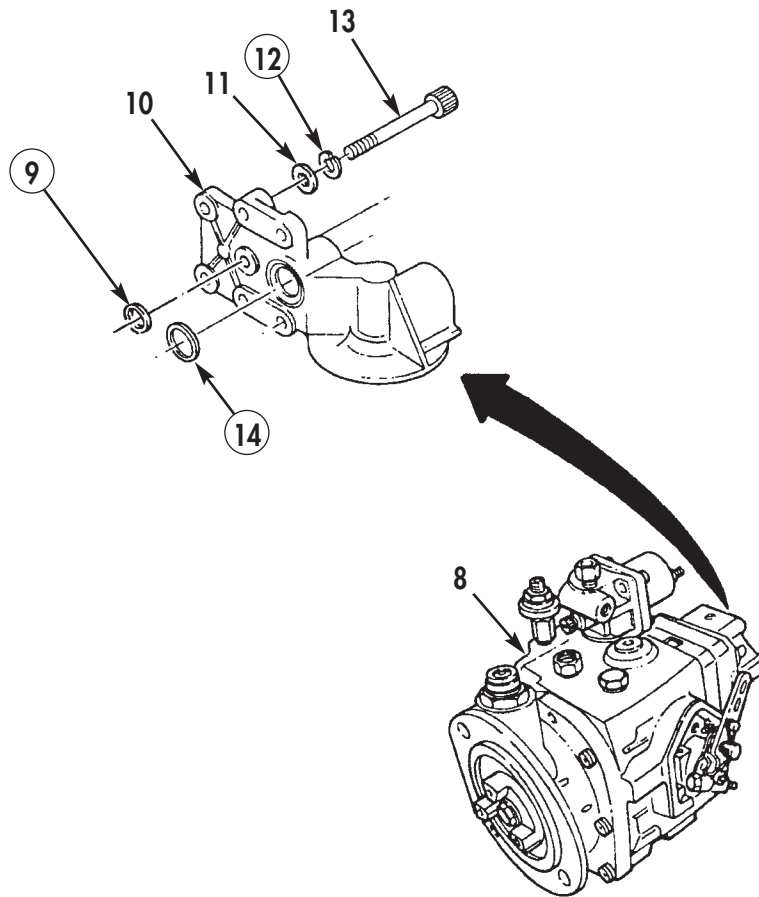


Figure 4. Fuel Damper and Head Installation.

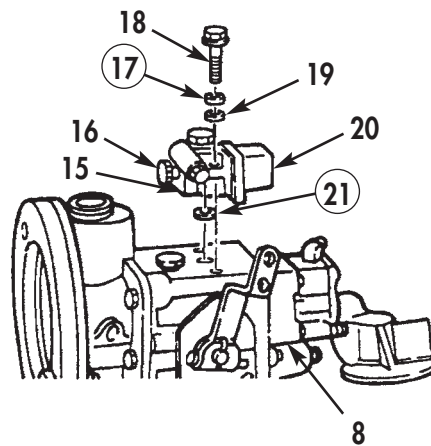


Figure 5. Solenoid Valve Installation.

END OF WORK PACKAGE

**DIRECT SUPPORT AND GENERAL SUPPORT
MAINTENANCE MANUAL
INCLUDING REPAIR PARTS AND SPECIAL TOOLS LIST (RPSTL)**

FOR

M915, M915A1, M915A4, M916, M920 VEHICLES

NSN 2815-01-082-8125	P/N NTC400-3652-02	CUMMINS NTC-400 BIG CAM I DIESEL ENGINE W/CONTAINER
NSN 2815-01-142-2745	P/N 11669835	CUMMINS NTC-400 BIG CAM III DIESEL ENGINE W/CONTAINER

WATER PUMP

DISASSEMBLY, CLEANING AND INSPECTION, ASSEMBLY

INITIAL SETUP:

Tools and Special Tools

General mechanic's tool kit:
 automotive (Item 1, WP 0061 00)
 Maintenance and repair shop equipment:
 automotive (Item 2, WP 0061 00)
 Automotive maintenance and repair
 supplemental set no. 2 (Item 3, WP 0061 00)
 Bearing disassembly fixture
 (Item 13, WP 0061 00)
 Water pump bearing mandrel
 (Item 14, WP 0061 00)
 Water pump seal mandrel
 (Item 15, WP 0061 00)
 Oil seal driver (Item 16, WP 0061 00)
 Oil seal pilot (Item 17, WP 0061 00)
 Press

Materials/Parts

Grease (Item 13, WP 0060 00)
 Loctite (Item 14, WP 0060 00)
 Lubricating oil (Item 19, WP 0060 00)
 Pipe sealant (Item 25, WP 0060 00)
 Grease fitting (Item 33, WP 0060 00)
 Seat and seal (Item 1, Table 24, WP 0062 00)
 Seal (Item 2, Table 24, WP 0062 00)
 Two bearings (Item 3, Table 24, WP 0062 00)
 Retaining ring (Item 4, Table 24, WP 0062 00)
 Retaining ring (Item 5, Table 24, WP 0062 00)
 Seal (Item 6, Table 24, WP 0062 00)
 Sleeve (Item 7, Table 24, WP 0062 00)
 Seal (Item 8, Table 24, WP 0062 00)
 Retaining ring (Item 9, Table 24, WP 0062 00)
 O-ring (Item 10, Table 24, WP 0062 00)
 Bearing (Item 11, Table 24, WP 0062 00)

Equipment Condition

Water pump removed from engine
 (TM 9-2320-273-20, TM 9-2320-283-20).

References

TM 9-2320-273-20
 TM 9-2320-283-20

WATER PUMP (Contd)

DISASSEMBLY

1. Remove screw (12), nut (15), washer (16), and idler pulley (18) with idler shaft (17) attached, from water pump housing (10).
2. Using puller, remove water pump pulley (1) from water pump shaft (8).
3. Using puller, remove impeller (14) from water pump shaft (8).
4. Remove seal (3) and retaining ring (4) from water pump housing (10). Discard seal (3) and retaining ring (4).
5. Remove water pump shaft (8) with two bearings (5), spacer (6), and retaining ring (7) attached from water pump housing (10).
6. Remove seat and seal assembly (13) and seal (19) from water pump housing (10). Discard seat and seal assembly (13) and seal (19).
7. Remove one large pipe plug (9) and two small pipe plugs (11) from water pump housing (10).
8. Using bearing disassembly fixture, remove bearing (5) and spacer (6) from water pump shaft (8). Discard bearing (5).
9. Remove retaining ring (7) from water pump shaft (8). Discard retaining ring (7).
10. Using bearing disassembly fixture, remove bearing (5) from water pump shaft (8). Discard bearing (5).
11. Using press and water pump bearing mandrel, remove sleeve (2) from water pump pulley (1). Discard sleeve (2).
12. Remove pipe plug (20) from idler pulley shaft (17).
13. Remove seal (24) from idler pulley (18). Discard seal (24).
14. Remove retaining ring (24), spacer (23), and O-ring (22) from idler shaft (17). Discard O-ring (22) and retaining ring (24).
15. Install idler pulley (18) with idler shaft (17) attached, in vise. Using a hammer and flat punch inserted through pipe plug opening in idler pulley (18), remove idler shaft (17) with bearing (21) attached, from idler pulley (19).
16. Remove idler pulley (18) from vise.
17. Using press and water pump bearing mandrel, remove bearing (21) from idler shaft (17). Discard bearing (21).

WATER PUMP (Contd)

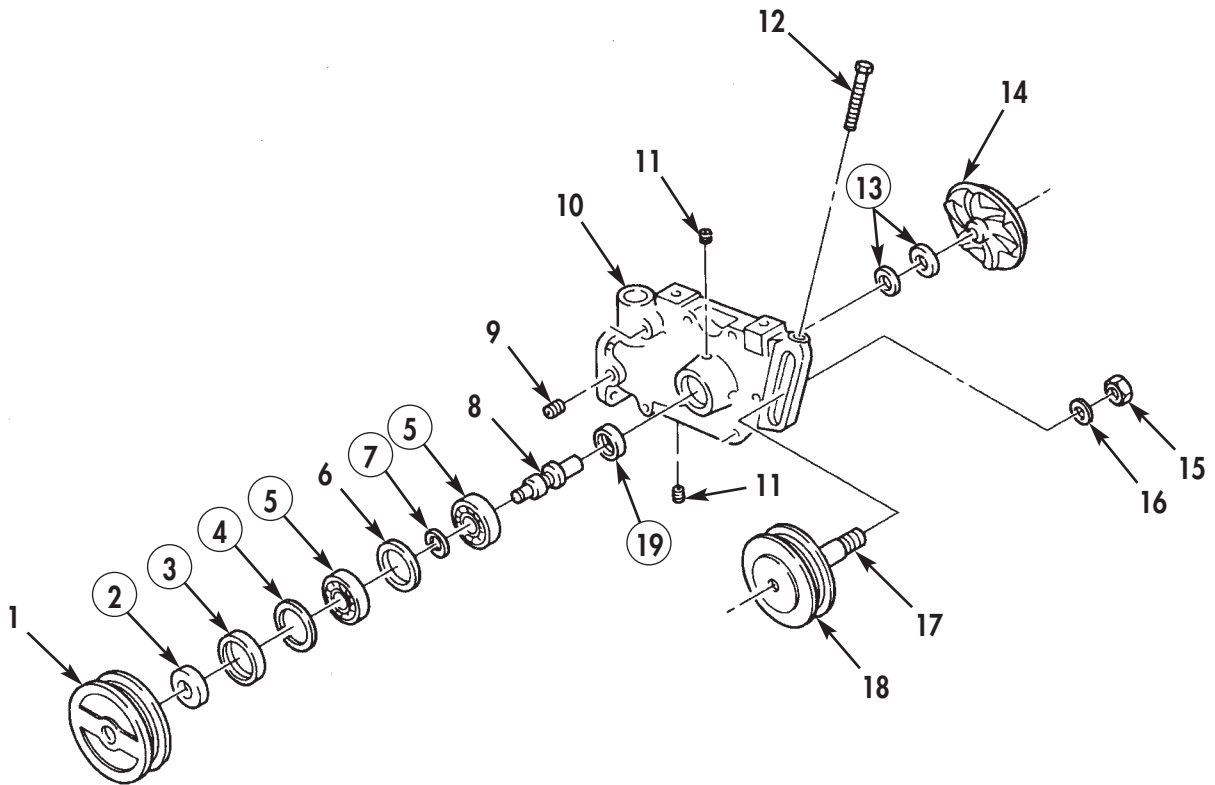


Figure 1. Water Pump Disassembly.

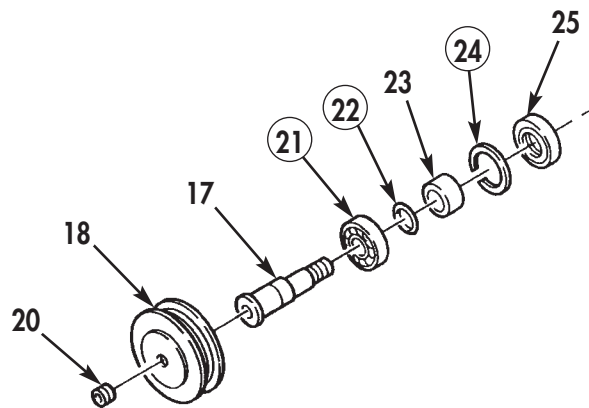


Figure 2. Water Pump Idler Pulley Disassembly.

WATER PUMP (Contd)

CLEANING AND INSPECTION

1. For general parts cleaning information, refer to CLEANING, WP 0051 00.
2. For general parts inspection information, refer to INSPECTION, WP 0051 00.

NOTE

Replace any part that does not pass visual inspection or is outside specified wear limits.

3. Inspect water pump pulley (1) and idler pulley (6) for cracks, chips, or damaged pulley grooves.
4. Inspect water pump housing (3) for cracks, corrosion, and stripped or elongated bolt holes. Repair any stripped holes.
5. Inspect water pump housing (3) weep hole for blockage. Clean weep hole if blocked.
6. Using inside micrometer, measure water pump housing (3) bearing bore. Discard water pump housing (3) if bearing bore is larger than 2.45 in. (62.22 mm).
7. Inspect impeller (4) for cracks, chips, or corrosion.

NOTE

Impeller must be 0.001 in. (0.025 mm) smaller than water pump shaft impeller end to maintain a press fit between components. Discard all parts that are out of specifications.

8. Using micrometer, measure water pump shaft impeller (4) end outside diameter. Diameter should be 0.6262–0.6267 in. (15.905–15.918 mm).
9. Using micrometer, measure water pump shaft (2) pulley end outside diameter. Diameter should be 0.6693–0.6696 in. (17.000–17.008 mm).

NOTE

Water pump pulley must be 0.001 in. (0.025 mm) smaller than water pump shaft pulley end to maintain a press fit between components. Discard all parts that are out of specifications.

10. Using inside micrometer, measure water pump pulley (1) bore inside diameter. Diameter should be 0.6663–0.6673 in. (16.924–16.949 mm).
11. Using inside micrometer, measure impeller (4) bore inside diameter. Diameter should be 0.624–0.625 in. (15.85–15.88 mm).
12. Inspect water pump shaft (2) and idler shaft (5) for cracks, bends, or damaged threads.

WATER PUMP (Contd)

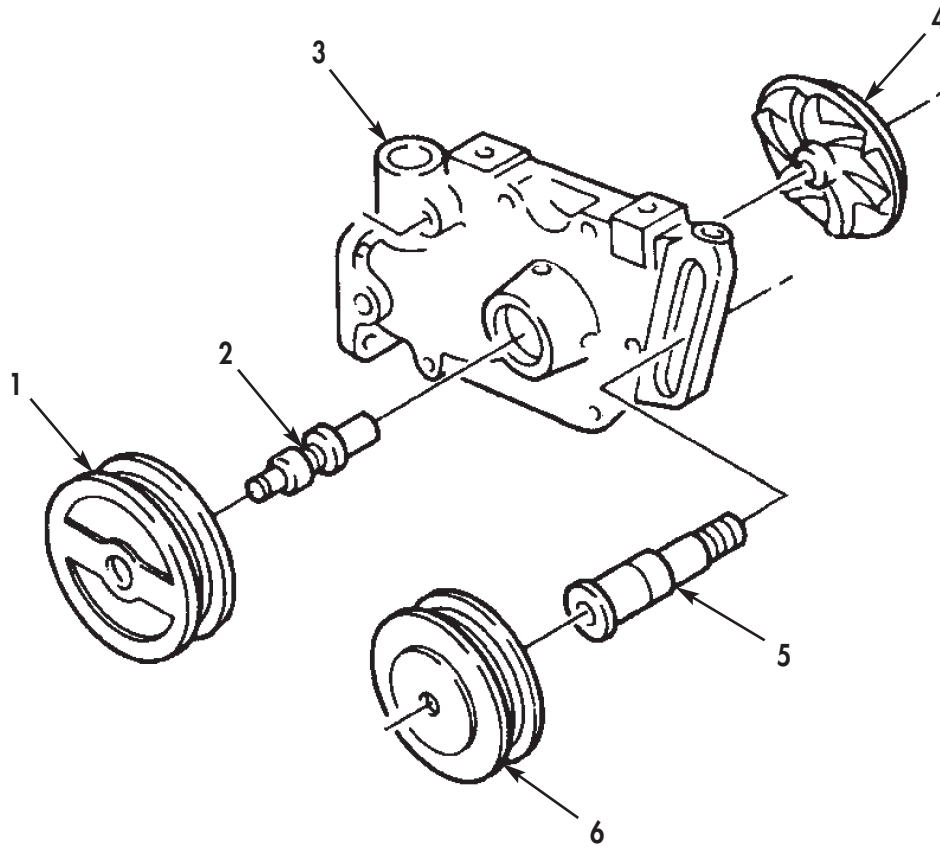


Figure 3. Water Pump Inspection.

WATER PUMP (Contd)

ASSEMBLY

NOTE

Lubricate all parts with lubricating oil before assembly.

1. Using press and water pump bearing mandrel, install new bearing (4) on idler shaft (3) until fully seated.
2. Apply light coat of Loctite to outside diameter of bearing (4). Using press and water pump bearing mandrel, install bearing (4) and idler shaft (3) in idler pulley (2) until fully seated.
3. Install new retaining ring (7), with flat side facing bearing (4), new O-ring (5), and spacer (6) on idler shaft (3).
4. Using oil seal driver, install new seal (8) in idler pulley (2) with seal lip facing idler pulley (2).
5. Apply pipe sealant to pipe plug (1) and install in idler pulley (2).
6. Using oil seal driver, install new sleeve (10) in water pump pulley (9).
7. Apply lubricating oil to new bearing (13). Using press and water pump bearing mandrel, install bearing (13) on water pump shaft (16) until fully seated.
8. Install new retaining ring (15) on water pump shaft (16).
9. Apply lubricating oil to new bearing (13). Using press and water pump bearing mandrel, install spacer (14) and bearing (13) on water pump shaft (16) until fully seated.
10. Using hammer, oil seal driver, and oil seal pilot, install new seal (25) in water pump housing (18).
11. Apply light coat of Loctite to outside diameter of bearings (13). Using press and water pump bearing mandrel, install bearings (13) with water pump shaft (16) attached, in water pump housing (18) until fully seated.
12. Install new retaining ring (12) in water pump housing (18), with flat side of retaining ring (12) facing bearing (13).
13. Using hammer, oil seal driver, and oil seal pilot, install new seal (11), with lip facing bearing (13), in water pump housing (18). Ensure seal (11) is flush with top edge of water pump housing (18) bore.
14. Apply light coat of Loctite to outside diameter of new seal and seat assembly (21), and apply one drop of retaining compound between seal and seat assembly (21). Using press and water pump seal mandrel, install seat and seal assembly (21) in water pump housing (18).
15. Apply pipe sealant to one long pipe plug (17) and two short pipe plugs (19) and install in water pump housing (18).
16. Apply light coat of Loctite to bore of water pump pulley (9). Using press, install water pump pulley (9) on water pump shaft (16) until fully seated.
17. Apply light coat of Loctite to bore of impeller (22). Using press, install impeller (22) on water pump shaft (16) until fully seated.
18. Using feeler gauge, check clearance between impeller (22) and water pump housing (18). Clearance should be 0.020–0.040 in. (0.508–1.016 mm).
19. Install idler pulley (2), with idler shaft (3) attached, on water pump housing (18) with washer (24) and nut (23).
20. Install screw (20) in water pump housing (18).
21. Install water pump (TM 9-2320-273-20 or TM 9-2320-283-20).

WATER PUMP (Contd)

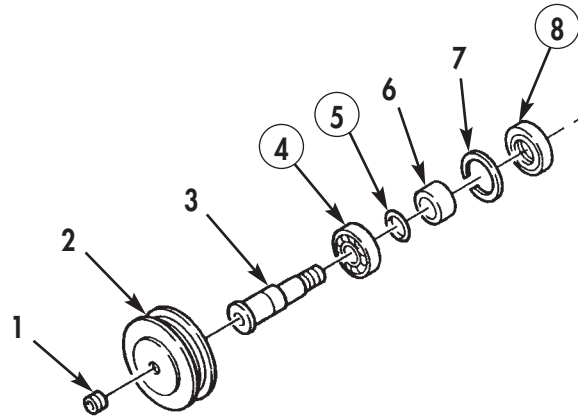


Figure 4. Water Pump Idler Pulley Assembly.

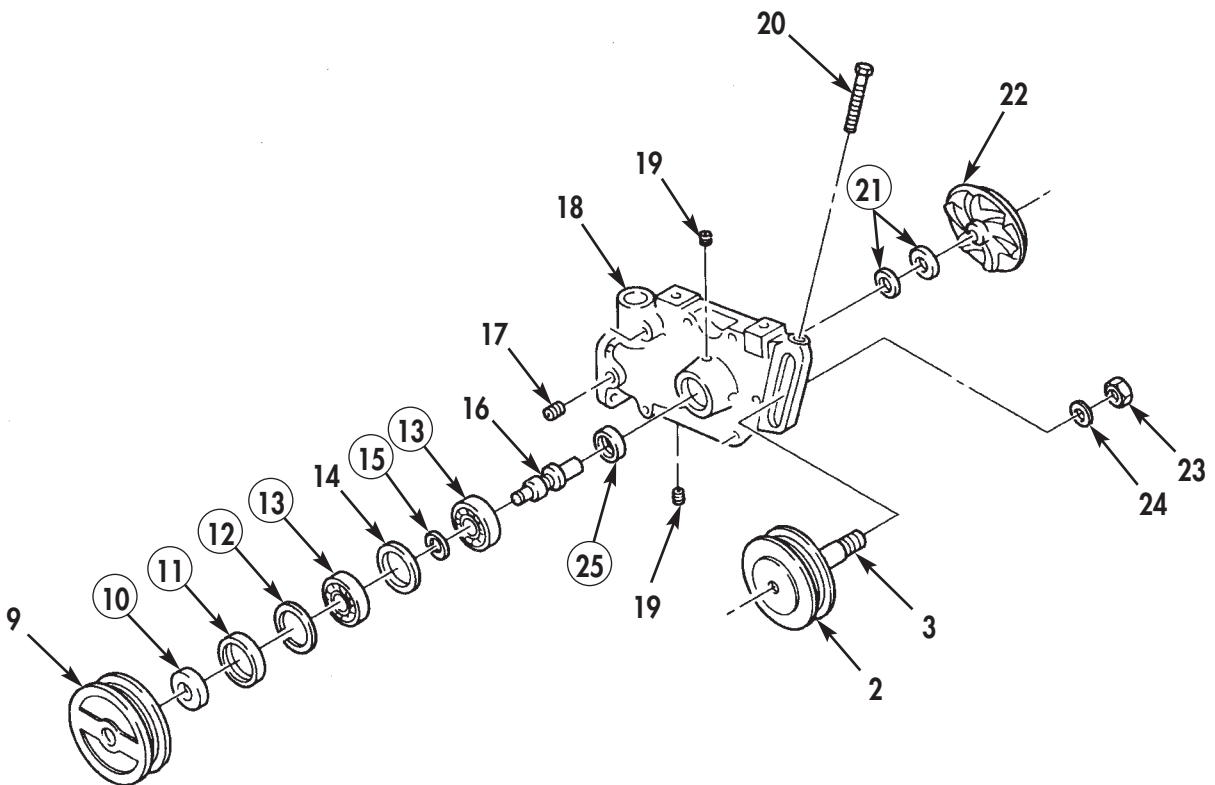


Figure 5. Water Pump Assembly.

END OF WORK PACKAGE

**DIRECT SUPPORT AND GENERAL SUPPORT
MAINTENANCE MANUAL
INCLUDING REPAIR PARTS AND SPECIAL TOOLS LIST (RPSTL)**

FOR

M915, M915A1, M915A4, M916, M920 VEHICLES

NSN 2815-01-082-8125	P/N NTC400-3652-02	CUMMINS NTC-400 BIG CAM I DIESEL ENGINE W/CONTAINER
NSN 2815-01-142-2745	P/N 11669835	CUMMINS NTC-400 BIG CAM III DIESEL ENGINE W/CONTAINER

CYLINDER BLOCK COMPONENTS INSTALLATION

**CRANKSHAFT AND MAIN BEARINGS; CAMSHAFT; PISTONS AND CONNECTING RODS;
ACCESSORY DRIVE HOUSING; OIL PUMP; ACCESSORY DRIVE PULLEY;
AIR COMPRESSOR; FRONT GEAR COVER; FLYWHEEL, FLEXPLATE, AND FLYWHEEL HOUSING; OIL PAN**

INITIAL SETUP:

Tools and Special Tools

General mechanic's tool kit: automotive
(Item 1, WP 0061 00)
Maintenance and repair shop equipment:
automotive (Item 2, WP 0061 00)
Automotive maintenance and repair supplemental
set no. 2 (Item 3, WP 0061 00)
Lifting strap
Prybar
Four camshaft pilot tools (Item 62, WP 0061 00)
Piston ring expander (Item 28, WP 0061 00)
Pulley installation assembly tool
(Item 63, WP 0061 00)
Crankshaft seal driver (Item 64, WP 0061 00)
Piston ring compressor (Item 65, WP 0061 00)

Material/Parts

Gasket (Item 1, Table 25, WP 0062 00)
Twelve compression rings
(Item 2, Table 25, WP 0062 00)
Gasket (Item 3, Table 25, WP 0062 00)
Four lockwashers (Item 4, Table 25, WP 0062 00)
Twelve compression rings
(Item 5, Table 25, WP 0062 00)
Six piston rings (Item 6, Table 25, WP 0062 00)
Rear main seal (Item 7, Table 25, WP 0062 00)
Four thrust bearing washers
(Item 8, Table 25, WP 0062 00)
Six piston rings (Item 9, Table 25, WP 0062 00)
Gasket (Item 10, Table 25, WP 0062 00)
Seal (Item 11, Table 25, WP 0062 00)
O-ring (Item 12, Table 25, WP 0062 00)
GAA grease (Item 13, WP 0060 00)
Fourteen main bearing halves
(Item 13, Table 25, WP 0062 00)

Material/Parts (Contd)

Cam follower housing gasket
(Item 14, Table 25, WP 0062 00)
Eighteen lockwashers
(Item 15, Table 25, WP 0062 00)
High-pressure lubricating oil (Item 15, WP 0060 00)
Gasket (Item 16, Table 25, WP 0062 00)
Gasket (Item 17, Table 25, WP 0062 00)
Twelve connecting rod bearing halves
(Item 18, Table 25, WP 0062 00)
Locknut (Item 19, Table 25, WP 0062 00)
Lubricating oil OHE/HDO 30 (Item 20, WP 0060 00)
Keyway seal (Item 20, Table 25, WP 0062 00)
Gasket (Item 21, Table 25, WP 0062 00)
60-80 lubricating oil (Item 21, WP 0060 00)
Fourteen lockplates (Item 22, Table 25, WP 0062 00)
Lockwasher (Item 23, Table 25, WP 0062 00)
Three lockwashers (Item 24, Table 25, WP 0062 00)
Eleven O-rings (Item 25, Table 25, WP 0062 00)
Pipe sealant (Item 25, WP 0060 00)
Nine lockwashers (Item 26, Table 25, WP 0062 00)
Thirteen lockwashers
(Item 27, Table 25, WP 0062 00)
Two lockwashers (Item 28, Table 25, WP 0062 00)
Gasket (Item 29, Table 25, WP 0062 00)
Four lockwashers (Item 30, Table 25, WP 0062 00)
Two O-rings (Item 31, Table 25, WP 0062 00)
Gasket (Item 32, Table 25, WP 0062 00)

Personnel Required

One assistant

Equipment Condition

Engine mounted on maintenance stand
(WP 0009 00)

CYLINDER BLOCK COMPONENTS INSTALLATION (Contd)

CRANKSHAFT AND MAIN BEARINGS

WARNING

Use extreme caution during assembly. Engine components are heavy. Failure to comply may result in damage to equipment or injury to personnel.

CAUTION

Cylinder block saddle and cap mating surfaces must be clean and dry when bearing halves are installed, or engine damage may result. Wipe main bearing bores, main bearings, engine crankshaft, and related parts with a clean cloth. Ensure cloth does not leave any particles or lint in or on parts and bores, or engine damage may result.

NOTE

Upper main bearings have a groove and oil hole to permit lubrication of engine crankshaft; the lower main bearing halves do not. The upper main bearings for No. 2, 4, and 6 are the same. The groove in upper main bearing half for No. 7 is not in the center. Install No. 7 main bearing so wider part of the bearing (from groove) is toward flywheel end of cylinder block. Each main bearing has a groove. Install main bearings so grooves will fit retaining rings.

Check for marks on crankshaft to determine size of main bearings and thrust rings. If there are no marks, use standard size parts.

1. Apply lubricating oil to seven new upper main bearing halves (2) and retaining rings (3). Install seven new upper main bearing halves (2) and retaining rings (3) on cylinder block (1).
2. Using lifting device or lifting strap, lower crankshaft (5) on cylinder block (1).

NOTE

Ensure grooved thrust side of thrust bearing washers is against the flange of crankshaft. Upper thrust rings are not doweled to cylinder block. Lower thrust bearing washers are doweled to No. 7 bearing cap.

3. Install four new upper thrust bearing washers (4) into position on No. 7 journal of crankshaft (5).

NOTE

Lubricate contact surface of seven lower main bearing halves and main bearing journal surface of crankshaft. Upper thrust rings are not doweled to cylinder block. Lower thrust bearing washers are doweled to No. 7 bearing cap.

4. Install seven new lower main bearing halves (2) on crankshaft (5). Ensure lower main bearing halves (2) are aligned with retaining rings (3).
5. Position No. 1 through No. 6 bearing caps (9) on cylinder block (1).
6. Install lower thrust bearing washers (4) on No.7 bearing cap (6).

CYLINDER BLOCK COMPONENTS INSTALLATION (Contd)

CRANKSHAFT AND MAIN BEARINGS (Contd)

7. Position No. 7 bearing cap (6) and thrust bearing washers (4) on cylinder block (1).
8. Apply OE/HDO 30 lubricating oil to threads of fourteen new screws (8) and new lockplates (7).
9. Install fourteen screws (8) and lockplates (7) on bearing caps (9) and (6) on cylinder block (1) finger-tight.

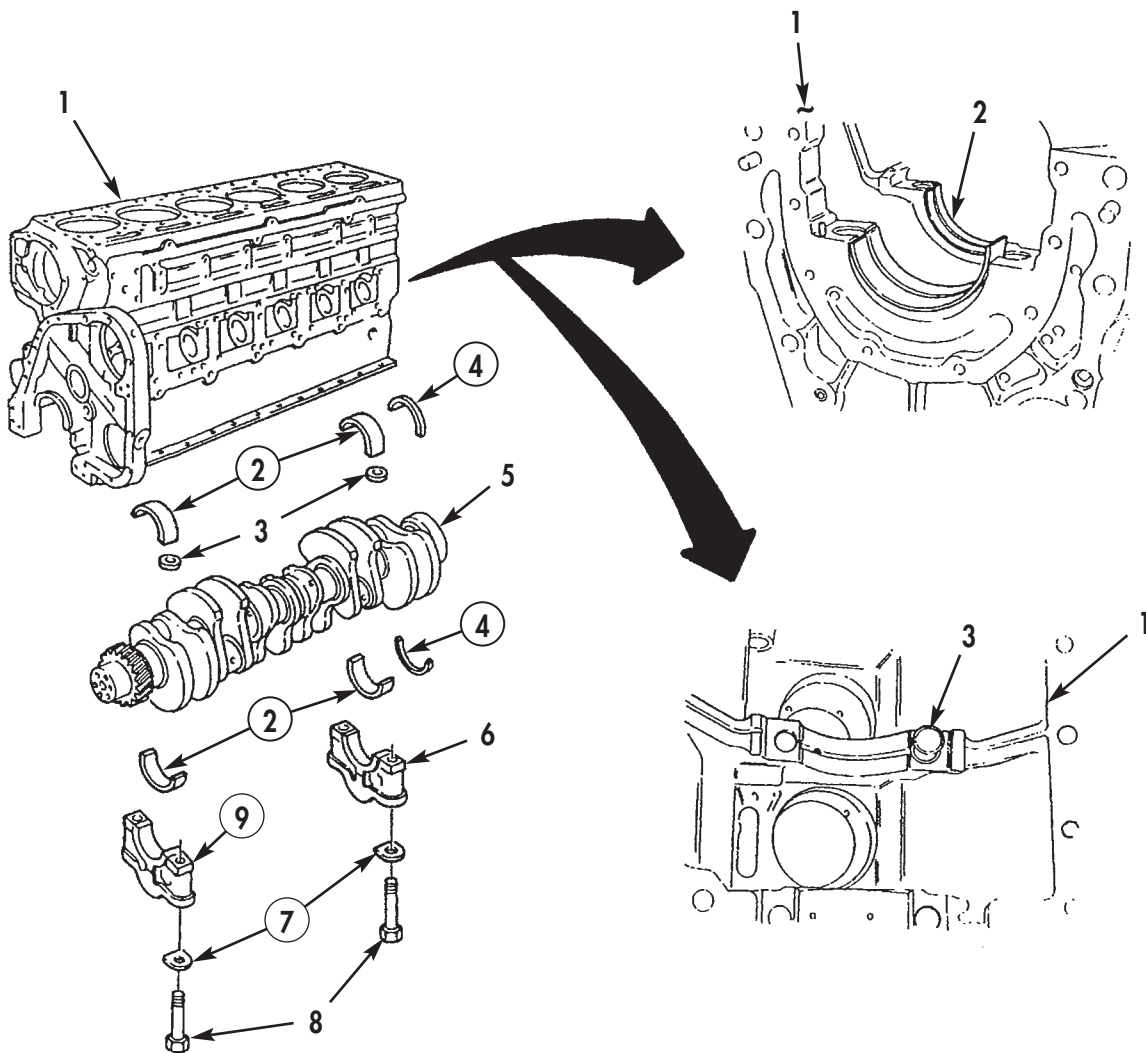


Figure 1. Crankshaft and Main Bearings Installation.

CYLINDER BLOCK COMPONENTS INSTALLATION (Contd)

CRANKSHAFT AND MAIN BEARINGS (Contd)

10. Using rubber mallet, strike bearing caps (2) into position on cylinder block (1).
11. Tighten screws (3) 250–260 lb-ft (339–353 N•m) in sequence as shown in figure 2.
12. Loosen fourteen screws (3) three to five threads, or a minimum of three complete turns.
13. Repeat step 11.
14. Using hands, rotate crankshaft (6). If crankshaft (6) does not rotate freely, refer to WP 0016 00, Crankshaft Cleaning and Inspection.
15. Install dial indicator on rear of cylinder block (1) with contact tip resting on crankshaft (6) flange end face.
16. Using prybar, pry crankshaft (6) toward front of cylinder block (1).
17. Remove prybar and set dial indicator to zero.
18. Pry crankshaft (6) toward rear of cylinder block (1). Total end clearance for new crankshaft (6) and new thrust bearing washers (4) should be 0.007–0.018 in. (0.178–0.457 mm). Maximum clearance for worn parts is 0.022 in. (0.559 mm).
19. If clearance is less than 0.007 in. (0.178 mm), proceed as follows:
 - a. Loosen fourteen screws (3) one turn.
 - b. Pry crankshaft (6) toward front and rear of cylinder block (1).
 - c. Tighten fourteen screws (3) according to steps 11–13.
 - d. Recheck end clearance.

NOTE

If clearance is more than 0.022 in. (0.559 mm), use oversize thrust bearing washer.

20. Bend tabs of fourteen lockplates (5) against heads of fourteen screws (3).

CYLINDER BLOCK COMPONENTS INSTALLATION (Contd)

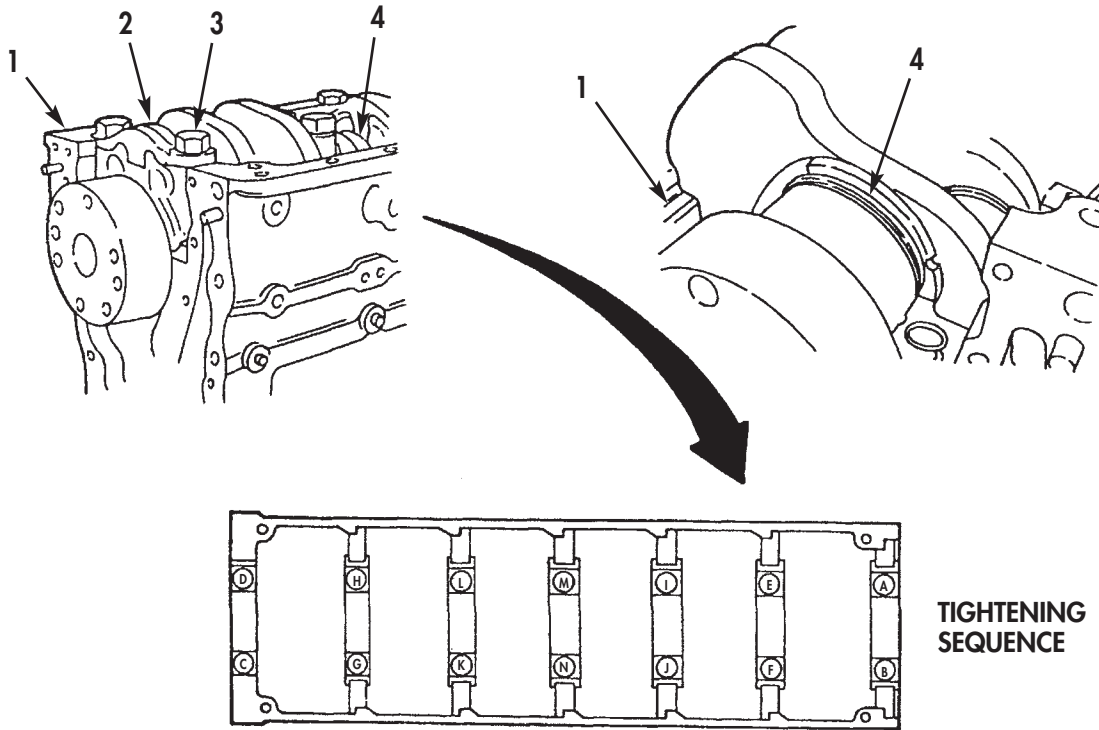


Figure 2. Main Bearings Installation.

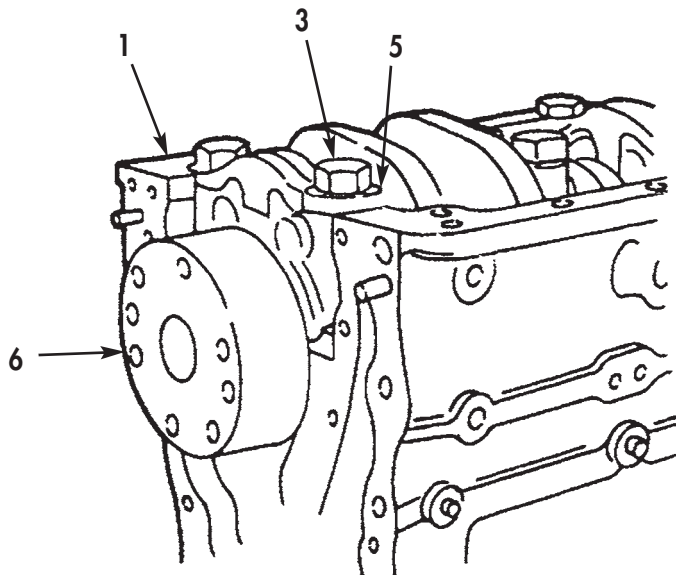


Figure 3. Crankshaft Installation.

CYLINDER BLOCK COMPONENTS INSTALLATION (Contd)

CAMSHAFT

CAUTION

The oil grooves on thrust washer must be installed facing camshaft gear, or thrust washer failure will result.

NOTE

Four camshaft pilot tools may be used to assist with camshaft installation.

1. Using high-pressure lubricant, coat both sides of thrust washer (3) and slide thrust washer (3) over end of camshaft (2) until seated next to camshaft gear (1).

NOTE

Lubricate cam lobes with high-pressure lubricant.

2. Apply high-pressure lubricant to camshaft (2) lobes.
3. Install camshaft (2) in cylinder block (4).
4. Line up timing mark O on camshaft gear (1) with timing mark O on crankshaft gear (10) and fully seat camshaft (2) and thrust washer (3) against cylinder block (4). Remove camshaft pilot tools from camshaft (2), if utilized.
5. Install dial indicator on front of cylinder block (4), and position tip of dial indicator against tooth on camshaft gear (1).
6. Rotate camshaft gear (1) as far as it will freely move. Ensure crankshaft gear (10) does not move.
7. Turn dial indicator to zero.
8. Rotate camshaft gear (1) in opposite direction as far as it will freely move. Dial indicator reading shows amount of backlash between gears.
9. Normal backlash is 0.004–0.016 in. (0.102–0.406 mm) between new camshaft gear (1) and new crankshaft gear (10). Minimum backlash for new camshaft gear (1) is 0.002 in. (0.051 mm). Gears will begin to make noise if backlash exceeds 0.010 in. (0.254 mm). If noise is acceptable, do not replace gears unless backlash exceeds 0.020 in. (0.508 mm).

NOTE

Perform steps 10 and 11 to install any one of the three cam follower assemblies. Repeat steps 10 and 11 as required to install each additional cam follower assembly.

Gaskets must be the same thickness as those removed. Total gasket thickness must be 0.014–0.080 in. (0.356–2.032 mm).

10. Install new cam follower housing gasket (6) on two dowel pins (5).

NOTE

Strike housing with soft-nose hammer to push it onto dowel pins on cylinder block.

11. Install cam follower housing (7) with six screws (8) and new lockwashers (9) on cylinder block (4). Tighten screws (8) 15 lb-ft (20 N•m) in tightening sequence shown in figure 4, and then tighten 30–35 lb-ft (41–48 N•m) in sequence shown in figure 4.

CYLINDER BLOCK COMPONENTS INSTALLATION (Contd)

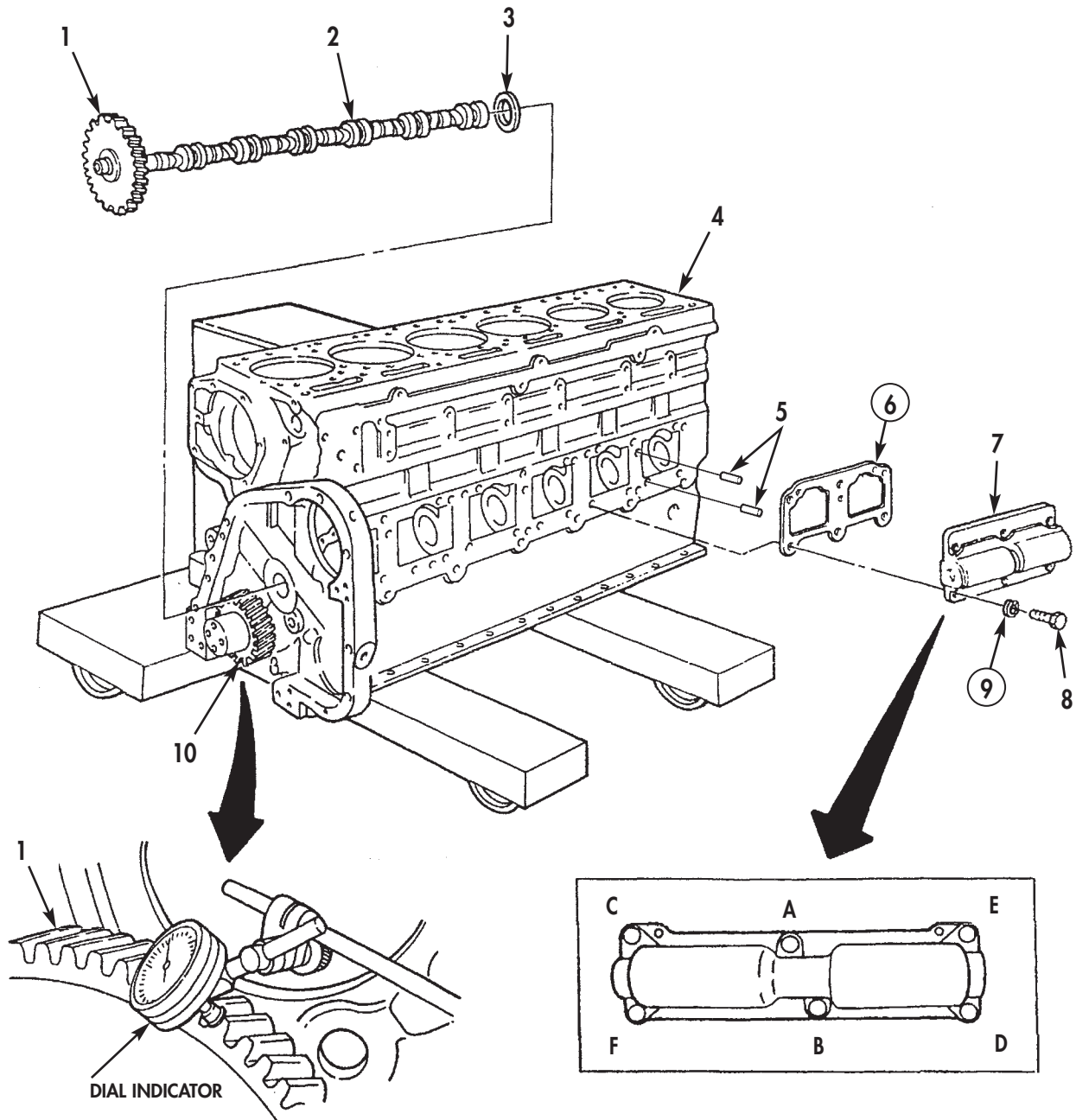


Figure 4. Cam Follower Installation.

CYLINDER BLOCK COMPONENTS INSTALLATION (Contd)

PISTONS AND CONNECTING RODS

NOTE

Perform steps 1 through 18 to install any one of the six piston, connecting rod, and bearings assemblies. Repeat for remaining piston, connecting rod and bearing assemblies.

Parts are not interchangeable. Do not mix parts from one assembly with another. Always replace bearing halves in pairs (upper and lower). Check for marks on crankshaft to determine bearing size. If there are no marks, use standard size parts.

1. Using piston ring expander, install two new compression rings (1) and (3) and two new piston rings (2) and (4) on piston and connecting rod assembly (5). Stagger ring gaps so they are not in line with each other or with piston pin.
2. Install new upper rod bearing half (7) on piston and connecting rod assembly (5). Ensure oil hole in bearing half (7) lines up with oil hole in connecting rod (6).
3. Install new lower rod bearing half (7) on connecting rod cap (8).
4. Using clean lubricating oil, lubricate two rod bearing halves (7).
5. Immerse piston (5) into container of clean lubricating oil.
6. Install two connecting rod guide pins (11) on piston and connecting rod assembly (5).
7. Using piston ring compressor, compress rings (1), (2), (3), and (4) on piston and connecting rod assembly (5).
8. Place cylinder block (12) in vertical position with rear of cylinder block (12) facing down.
9. Rotate crankshaft (10) until journal for piston and connecting rod assembly (5) is installed at bottom dead center.
10. Position piston and connecting rod assembly (5) toward camshaft side of cylinder block (12).

NOTE

Guide connecting rod on journal of crankshaft as piston is installed on cylinder liner.

11. Push piston (5) through piston ring compressor and into cylinder liner (13). Ensure piston (5) moves freely in cylinder liner (13). If piston (5) does not move freely, remove and check for broken rings.
12. Using connecting rod guide pins (11), pull connecting rod (6) in position against crankshaft (10).
13. Remove two connecting rod guide pins (11) from piston and connecting rod assembly (5).
14. Install connecting rod cap (8) on crankshaft (10) and on piston and connecting rod assembly (5). Ensure numbered side of connecting rod cap (8) is on same side as numbered side of connecting rod assembly (5).
15. Using lubricating oil, lubricate two bolts (9).
16. Install two bolts (9) on connecting rod cap (8) and connecting rod (6). Tighten bolts (9) as shown in table 1.
17. Check piston and connecting rod assembly (5) side-to-side movement. Piston and connecting rod assembly (5) must move freely on crankshaft journal with hand pressure. If connecting rod does not move freely, remove connecting rod cap (8) and check for dirt, damage, or improper bearing half (7).
18. Using feeler gauge, check side clearance of connecting rod cap (8) and crankshaft (10). Side clearance must be 0.004–0.013 in. (0.102–0.330 mm).

CYLINDER BLOCK COMPONENTS INSTALLATION (Contd)

PISTONS AND CONNECTING RODS (Contd)

Table 1. Tightening Sequence for Piston and Connecting Rod Bolts.

STEP SEQUENCE	MINIMUM	MAXIMUM
1. Tighten to	70 lb-ft (95 N•m)	75 lb-ft (102 N•m)
2. Tighten to	140 lb-ft (190 N•m)	150 lb-ft (230 N•m)
3. Loosen completely	—	—
4. Tighten to	25 lb-ft (34 N•m)	30 lb-ft (41 N•m)
5. Tighten to	70 lb-ft (95 N•m)	75 lb-ft (102 N•m)
6. Tighten to	140 lb-ft (190 N•m)	150 lb-ft (230 N•m)

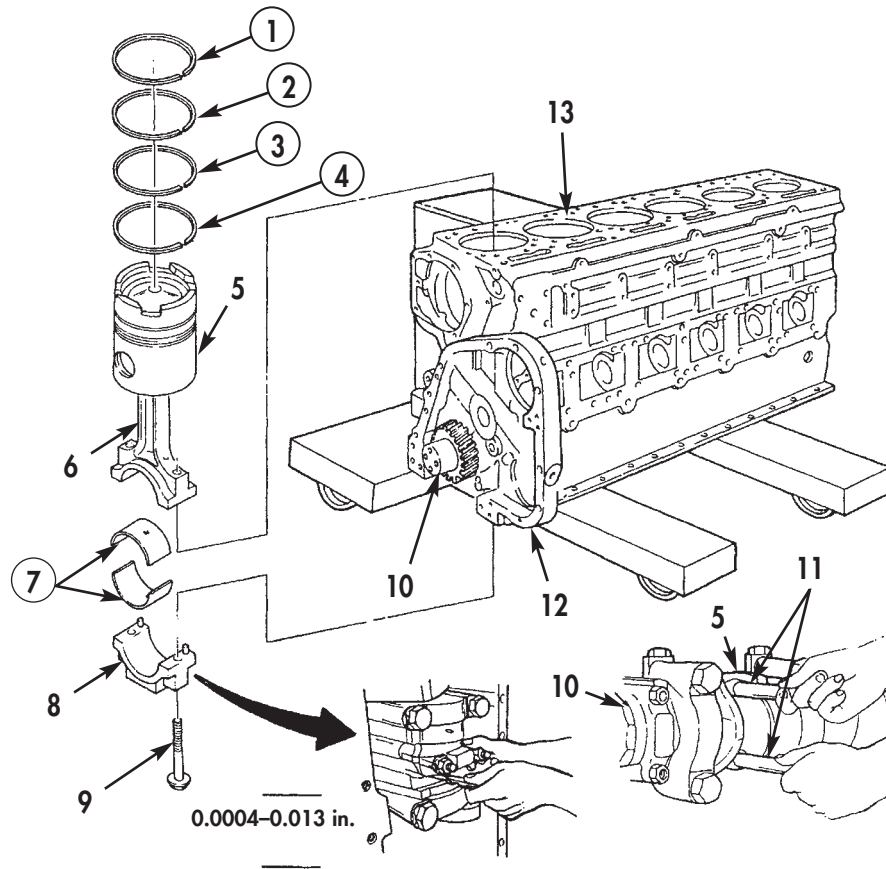


Figure 5. Piston and Connecting Rod Installation.

CYLINDER BLOCK COMPONENTS INSTALLATION (Contd)

ACCESSORY DRIVE HOUSING

NOTE

Rotate crankshaft clockwise when facing front of crankshaft.

1. Turn crankshaft (5) in direction of engine rotation until No. 1 cylinder is at Top Dead Center (TDC) of compression stroke (6).
2. Turn crankshaft (5) in direction of engine rotation to 90° past TDC (7).
3. Position accessory drive housing (3) and new gasket (2) on cylinder block (1). Ensure that timing mark on accessory drive gear (9) lines up with timing mark on camshaft gear (8). This alignment is necessary so that valve and injector adjustments marks on accessory drive pulley will be correctly aligned.
4. Install five bolts (4) on accessory drive housing (3). Tighten bolts (4) 40–45 lb-ft (54–61 N•m).
5. Install dial indicator on front of cylinder block (1) and position tip of dial indicator against tooth of accessory drive gear (9).
6. Rotate accessory drive gear (9) as far as it will freely move. Ensure camshaft gear (8) does not move.
7. Turn dial on indicator to zero and rotate accessory drive gear (9) in opposite direction. Reading on dial indicator shows amount of backlash between gears.
8. Normal backlash between new accessory drive gear (9) and new camshaft gear (8) is 0.004–0.016 in. (0.102–0.406 mm). Backlash for new accessory drive gear (9) must be at least 0.002 in. (0.051 mm). If backlash is more than 0.016 in. (0.406 mm), remove accessory drive housing (3) and replace accessory drive gear (9).

CYLINDER BLOCK COMPONENTS INSTALLATION (Contd)

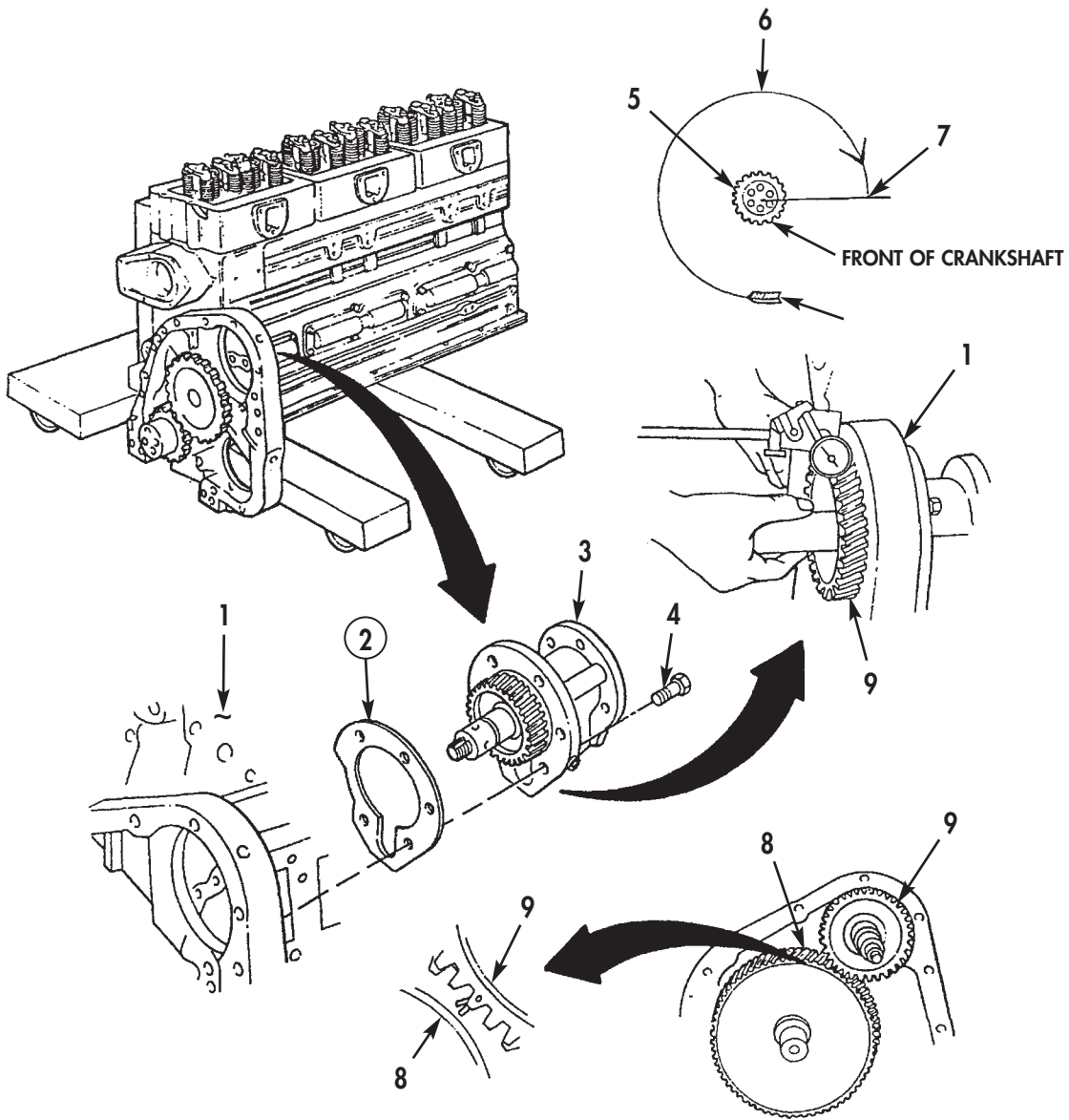


Figure 6. Accessory Drive Housing Installation.

CYLINDER BLOCK COMPONENTS INSTALLATION (Contd)

OIL PUMP

NOTE

Perform steps 1 through 6 for Big Cam III only.

1. Apply pipe sealant to threads of elbow (2).
2. Install elbow (2) on cylinder block (1).
3. Apply pipe sealant to threads of oil transfer tube (3).
4. Install oil transfer tube (3) on elbow (2).
5. Install loose end of oil transfer tube (3) on oil pump (6).
6. Install oil pump (6) and new gasket (7) on cylinder block (1) with five bolts (4) and new lockwashers (5). Tighten bolts (4) 45 lb-ft (61 N•m).

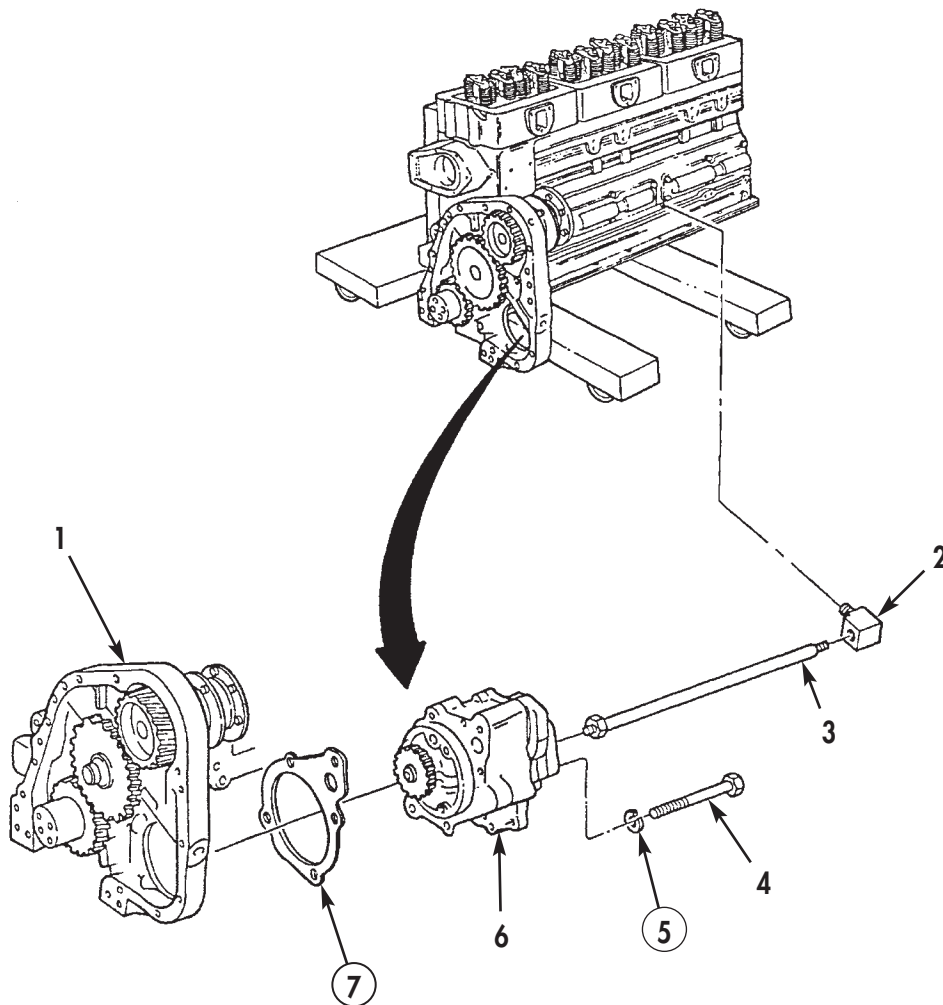


Figure 7. Oil Transfer Tube and Elbow Installation.

CYLINDER BLOCK COMPONENTS INSTALLATION (Contd)

OIL PUMP (Contd)

NOTE

Perform step 7 for Big Cam I only.

7. Install oil pump (13) and new gasket (14) on cylinder block (1) with five new lockwashers (12), two short bolts (11), and three long bolts (10). Tighten bolts (10) and (11) 40 lb-ft (54 N•m).
8. Install dial indicator and dial gauge attachment on front of cylinder block (1), and position tip of dial indicator against tooth of pump drive gear (8).
9. Rotate pump drive gear (8) as far as it will freely move. Ensure that camshaft gear (15) does not move.
10. Turn dial indicator to zero.
11. Rotate pump drive gear (8) in opposite direction. The reading of dial indicator shows the amount of backlash between gears. Minimum backlash is 0.002 in. (0.051 mm) and maximum backlash is 0.016 in. (0.406 mm). Replace pump drive gear if not within specifications.

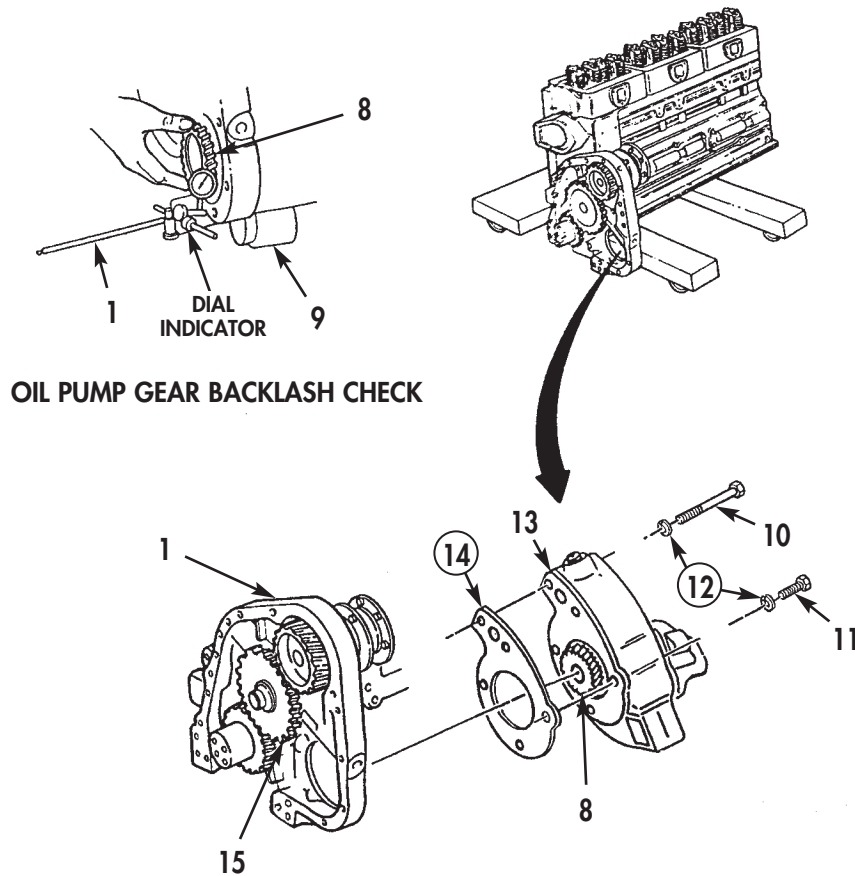


Figure 8. Oil Pump Installation.

CYLINDER BLOCK COMPONENTS INSTALLATION (Contd)

ACCESSORY DRIVE PULLEY

NOTE

Remove pipe plug from front gear cover and ensure timing marks on camshaft gear and accessory drive gear are aligned. Reinstall pipe plug in front gear cover and torque to 35–45 lb-ft (48–61 N•m).

1. Apply high pressure lubricant to accessory driveshaft (7).

NOTE

Ensure short leg of keyway seal faces toward inside of accessory drive shaft.

2. Install new keyway seal (5) on accessory driveshaft (7).

NOTE

Perform steps 3 through 5 for Big Cam I engines only.

3. Align accessory drive pulley (4) keyway with dowel pin (8) on accessory driveshaft (7).
4. Using pulley installation tool, install accessory drive pulley (4) on accessory driveshaft (7).
5. Align keyway seal (5) on keyway of accessory drive pulley (4). Ensure short leg of keyway seal (5) faces toward inside of accessory driveshaft (7) and washer (3) or it will crush against L of seal (5).

NOTE

Perform steps 6 through 8 for Big Cam III only.

6. Align accessory drive pulley (6) keyway with dowel pin (8) on accessory driveshaft (7).
7. Align new keyway seal (5) on keyway of accessory drive pulley (6). Ensure short leg of keyway seal (5) faces toward inside of accessory driveshaft (7) and washer (3) or it will crush against L of seal (5).

NOTE

Hold crankshaft at flywheel end when applying torque.

8. Install new locknut (2) and washer (3) on accessory driveshaft (7). Tighten locknut (2) 300–310 lb-ft (407–420 N•m).

NOTE

Perform step 9 for Big Cam III only.

9. Position accessory drive pulley assembly (4) on accessory drive pulley (6) with six bolts (1). Tighten bolts 40–45 lb-ft (54–61 N•m).

CYLINDER BLOCK COMPONENTS INSTALLATION (Contd)

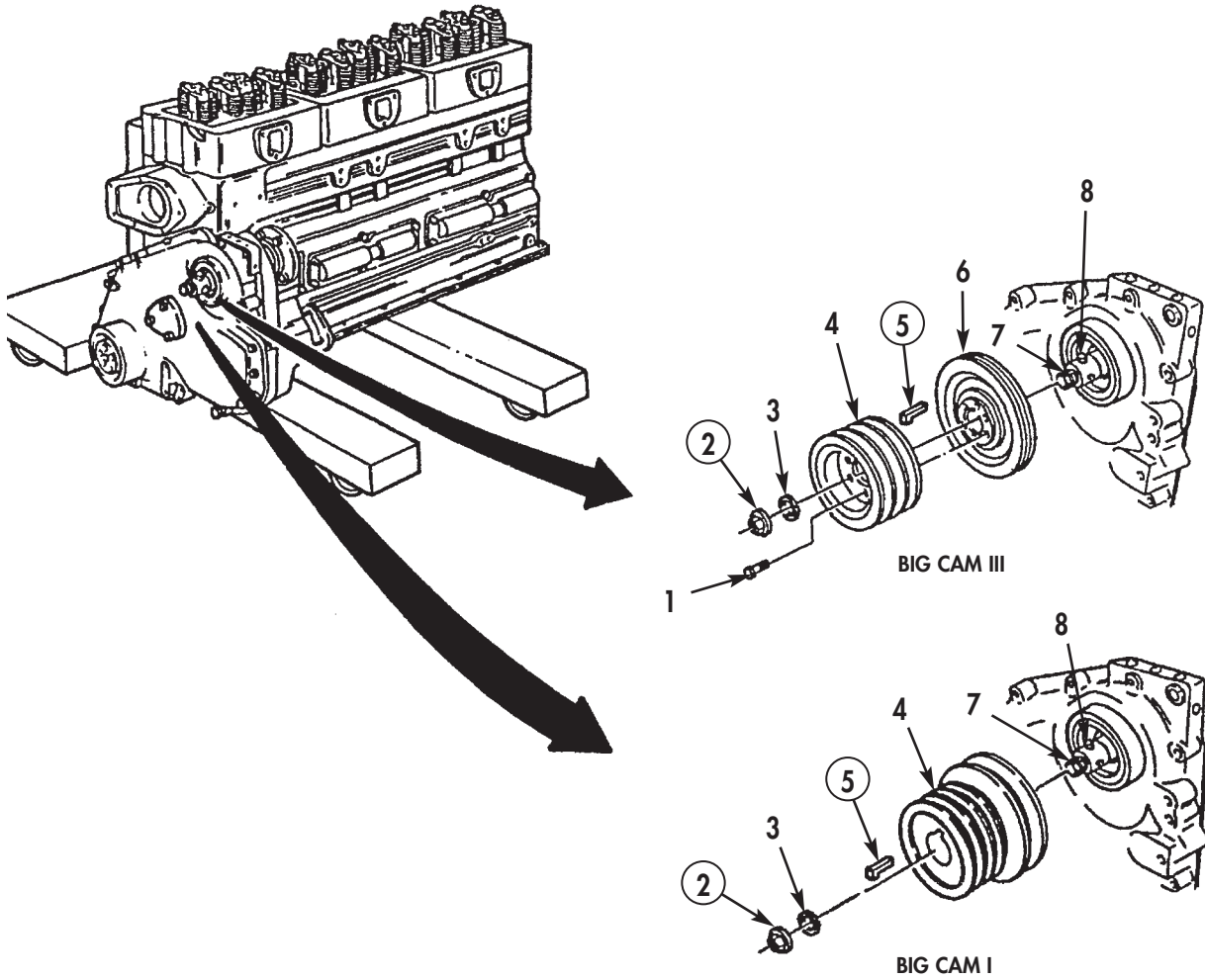


Figure 9. Accessory Drive Pulley Installation.

CYLINDER BLOCK COMPONENTS INSTALLATION (Contd)

AIR COMPRESSOR

NOTE

Air compressor must be timed to engine firing order.

1. Rotate crankshaft (1) until valve set mark A on accessory drive pulley (2) is aligned with pointer (13) on front gear cover (3).
2. Rotate air compressor crankshaft (14) until scribe mark on hub is positioned halfway between 9 and 10 o'clock.
3. Install drive coupling (5) on air compressor (10).
4. Install air compressor (10) and new gasket (6) on accessory drive housing (11) with two screws (4) and (12), washers (7), four new lockwashers (8), and two nuts (9). Using air compressor wrench, tighten screws (4) and (12) 40–45 lb-ft (54–62 N•m).

CYLINDER BLOCK COMPONENTS INSTALLATION (Contd)

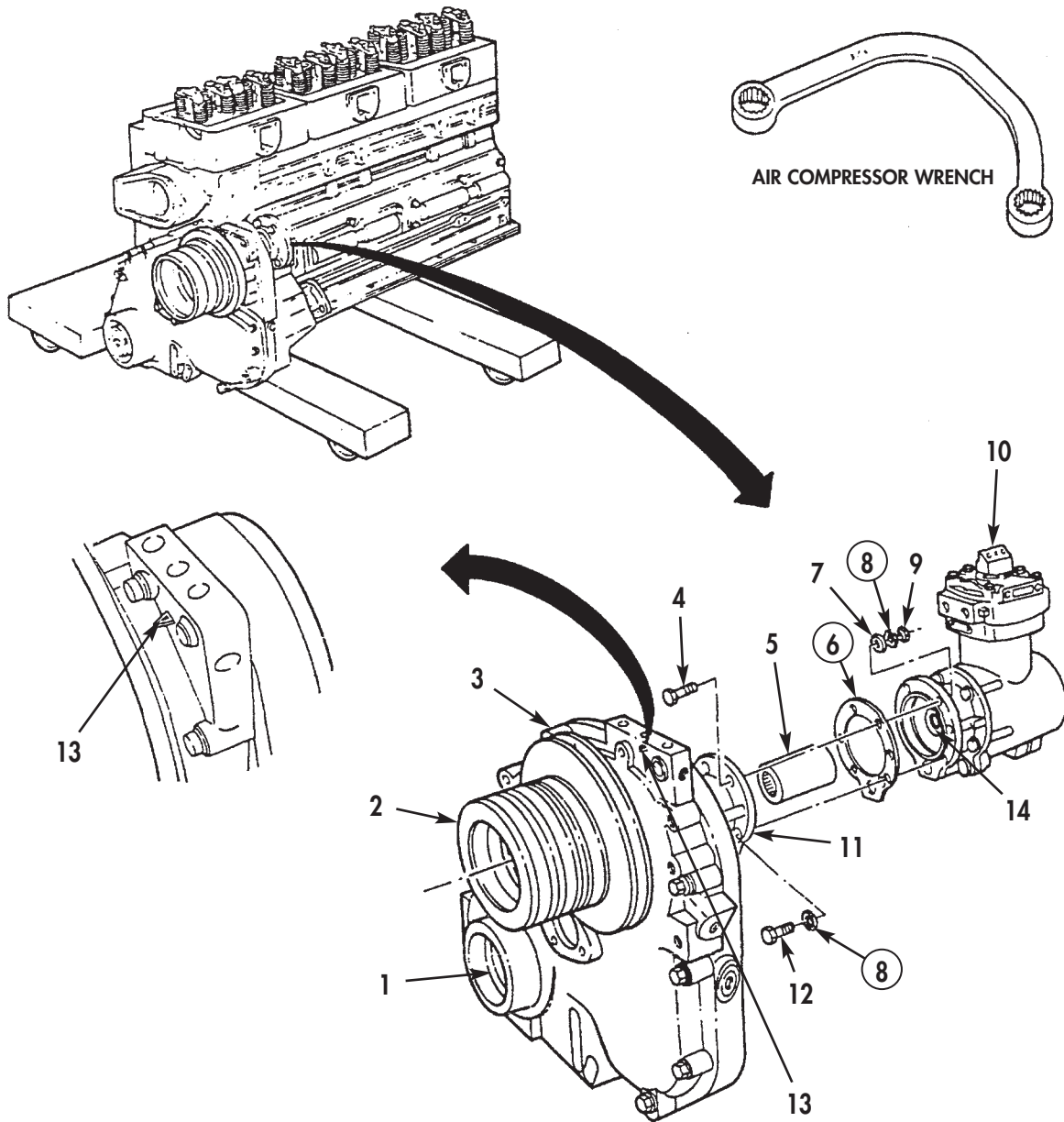


Figure 10. Drive Coupling Installation.

CYLINDER BLOCK COMPONENTS INSTALLATION (Contd)

AIR COMPRESSOR (Contd)

5. Apply pipe sealant to threads of plug (11), and install air inlet connector (10) and new gasket (12) on air compressor (1) with two washers (8), new lockwashers (7), screws (9) and (6), and plug (11).
6. Install two air inlet hoses (3) and tube (5) on air inlet connector (10) and elbow (2) with four clamps (4).
7. Apply pipe sealant to threads of three adapters (15) and, install adapters (15), coupling (17), and elbow (18) on air compressor (1).
8. Install four bushings (14), coolant outlet tube (13), and coolant inlet tube (16) on three adapters (15) and elbow (18).

CYLINDER BLOCK COMPONENTS INSTALLATION (Contd)

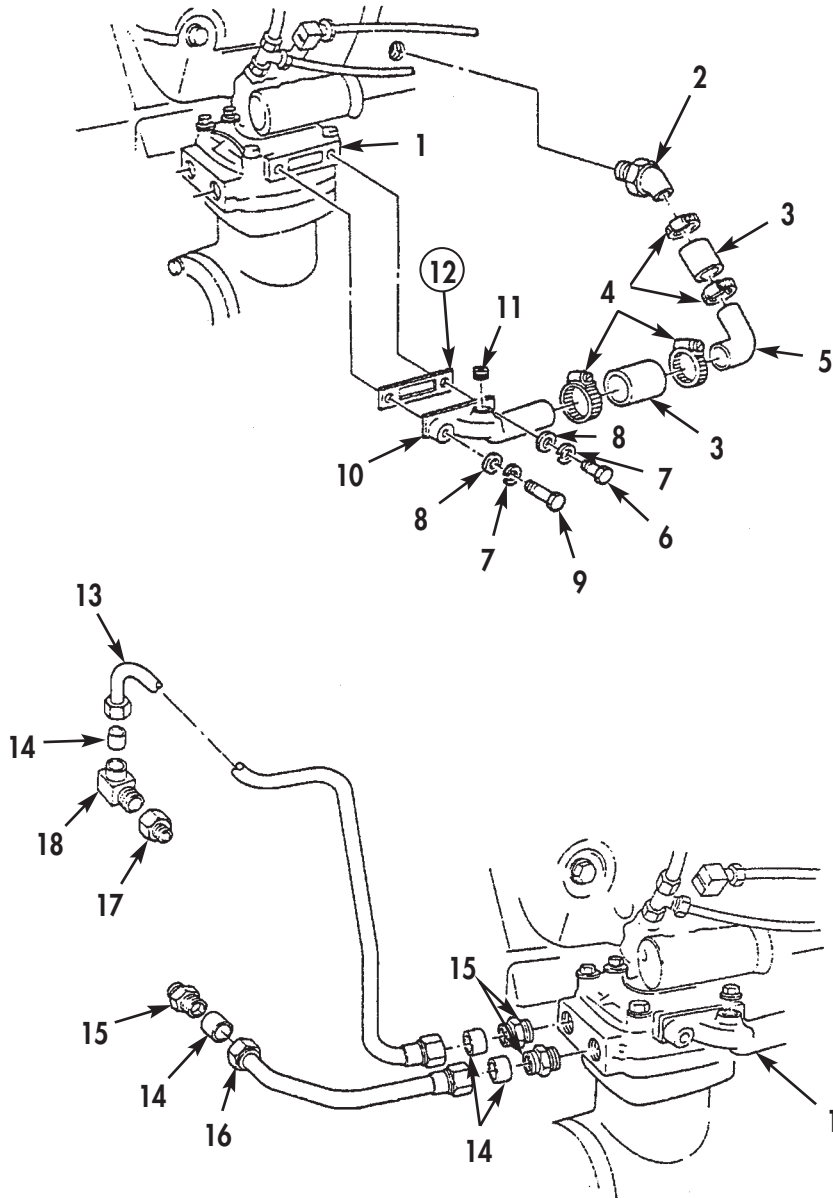


Figure 11. Air Compressor Installation.

CYLINDER BLOCK COMPONENTS INSTALLATION (Contd)

FRONT GEAR COVER

NOTE

Perform step 1 for Big Cam I only.

1. Remove three screws (4), lockwashers (18), and washers (17) from camshaft support (5).

NOTE

Perform step 2 for Big Cam III only.

2. Remove three screws (4) from camshaft support (5).
3. Remove camshaft support (5), shim pack (6), and seal (7) from gear cover (11).

CAUTION

All surfaces in contact with oil seals must be completely free of oil. Oil on a Teflon seal will destroy its sealing properties.

4. Coat new gasket (12) with high pressure lubricant and install on gear cover (11).
5. Install gear cover (11) and gasket (12) on two dowels (13) and cylinder block (14).

NOTE

Perform step 6 for Big Cam I only.

6. Install screw (8), new lockwasher (9), washer (10), screw (15), and nine screws (16) on gear cover (11) and cylinder block (14). Tighten screws (16), (8), and (15) 45–55 lb-ft (61–75 N•m).

NOTE

Perform step 7 for Big Cam III only.

7. Install three screws (8), screw (15), and nine screws (16) on gear cover (11) and cylinder block (14). Tighten screws (8), (15), and (16) 45–55 lb-ft (61–75 N•m).
8. Position front engine support (3) on gear cover (11).

NOTE

Perform step 9 for Big Cam I only.

9. Install six screws (1), washers (2), two screws (20), and washers (19) on front engine support (3) and gear cover (11). Tighten screws (1) and (20) 45–55 lb-ft (61–75 N•m).

NOTE

Perform step 10 for Big Cam III only.

10. Install six screws (1), washers (2), and two screws (20) on front engine support (3) and gear cover (11). Tighten screws (1) and (20) 45–55 lb-ft (61–75 N•m).

NOTE

Trim off excess gasket material so gasket is even with oil pan mounting flange.

11. Using straightedge and feeler gauge, check alignment of oil pan mounting flange on gear cover (11) with oil pan mounting flange on cylinder block (14). Gear cover flange must be even with front cylinder block flange within 0.004 in. (0.102 mm).

CYLINDER BLOCK COMPONENTS INSTALLATION (Contd)

FRONT GEAR COVER (Contd)

12. Install dial indicator on front of crankshaft and position tip of dial indicator against inner surface of crankshaft seal bore.
13. Turn dial of indicator to zero.
14. Rotate crankshaft one complete revolution. Reading on dial indicator shows difference. If total dial indicator reading exceeds 0.010 in. (0.254 mm), remove, clean, and relocate between common centers.
15. Remove shim pack (6) and seal (7) from camshaft support (5).
16. Install camshaft support (5) on gear cover (11) and hold against end of camshaft. Ensure camshaft is pushed against cylinder block (14).
17. Using feeler gauge, measure space between mounting flange of camshaft support (5) and gear cover (11). Use measurement to determine thickness of shim pack (6) needed to provide 0.008–0.130 in. (0.203–3.302 mm) clearance. Shim packs (6) are available in four different thicknesses.
18. Remove camshaft support (5) from gear cover (11).
19. Install shim pack (6) and new seal (7) on camshaft support (5).
20. Install camshaft support (5), shim pack (6), and seal (7) on gear cover (11).

NOTE

Perform step 21 for Big Cam I only.

21. Install three screws (4), new lockwashers (18), and washers (17) on camshaft support (5). Tighten screws (4) 15–20 lb-ft. (20–27 N•m).

NOTE

Perform step 22 for Big Cam III only.

22. Install three screws (4) on camshaft support (5). Tighten screws (4) 15–20 lb-ft. (20–27 N•m).

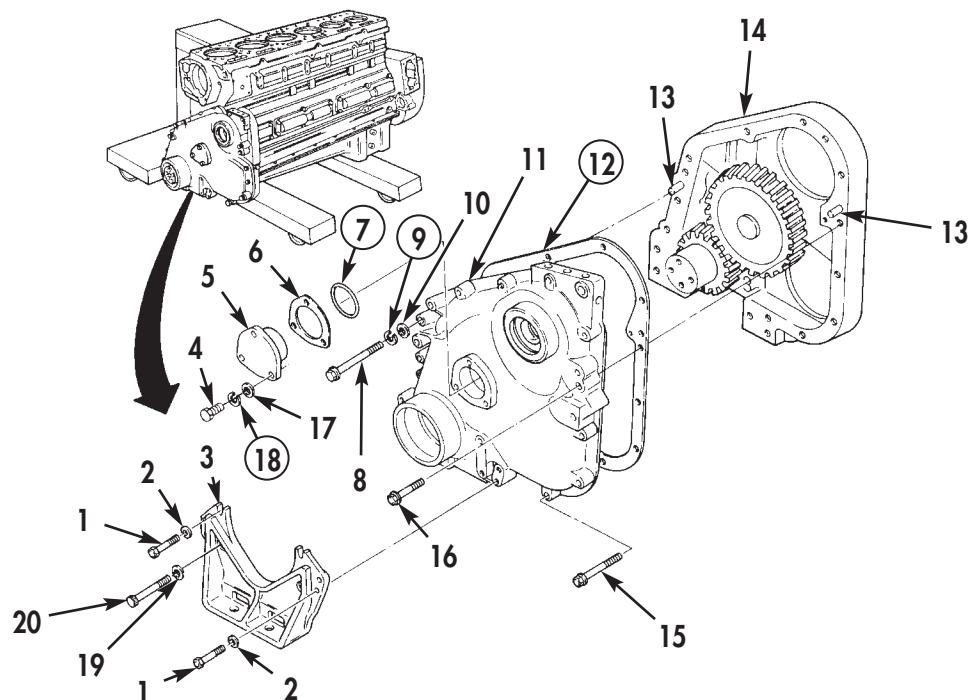


Figure 12. Front Cover Installation.

CYLINDER BLOCK COMPONENTS INSTALLATION (Contd)

FLYWHEEL, FLEXPLATE, AND FLYWHEEL HOUSING

1. Install new gasket (3) and rear cover (4) on cylinder block (2) with eight screws (5). Tighten screws (5) only enough to hold rear cover (4) in position.
2. Using crankshaft oil seal driver, align rear cover (4) with crankshaft (1).
3. Using dial indicator, check alignment of rear cover (4) to crankshaft (1). Rear cover (4) must be on common center with crankshaft (1) within 0.010 in. (0.254 mm). Rear cover (4) must be square to centerline of crankshaft (1) within 0.010 in. (0.254 mm). Rear cover (4) must be within 0.004 in. (0.102 mm) of being flat with oil pan flange of cylinder block (2).
4. Tighten eight screws (5) 30–35 lb-ft (41–48 N•m). Cut off excess gasket (3) material so that gasket (3) is even with, or not more than, 0.010 in. (0.254 mm) above oil pan flange.

NOTE

New rear main seals have an assembly tool which protects seal lip during shipment and installation. Do not use any lubricant to install seal. Oil seal must be installed with lip of seal and crankshaft clean and dry.

5. Install new rear main seal (6) on crankshaft (1). Position largest diameter of assembly tool toward cylinder block (2).
6. Push rear main seal (6) from assembly tool onto crankshaft (1). Using crankshaft rear oil seal driver, drive rear main seal (6) on rear cover (4).
7. Remove two dowel pins (12) if installing new flywheel housing (9), or if dowel is damaged or outside diameter is less than 0.5005 in. (12.713 mm), and install two flywheel housing guide pins in their place.

NOTE

Perform steps 8 and 9 for Big Cam I only.

8. Install new seal (7) on crankshaft (1).
9. Install eleven new O-rings (8) on flywheel housing (9).
10. Install flywheel housing (9) on cylinder block (2) with seven of nine screws (10) and washers (11). Tighten screws (10) 10–20 lb-ft (14–27 N•m).
11. Remove two flywheel housing (9) guide pins, if installed, and install two remaining screws (10) and washers (11) on flywheel housing (9).

CYLINDER BLOCK COMPONENTS INSTALLATION (Contd)

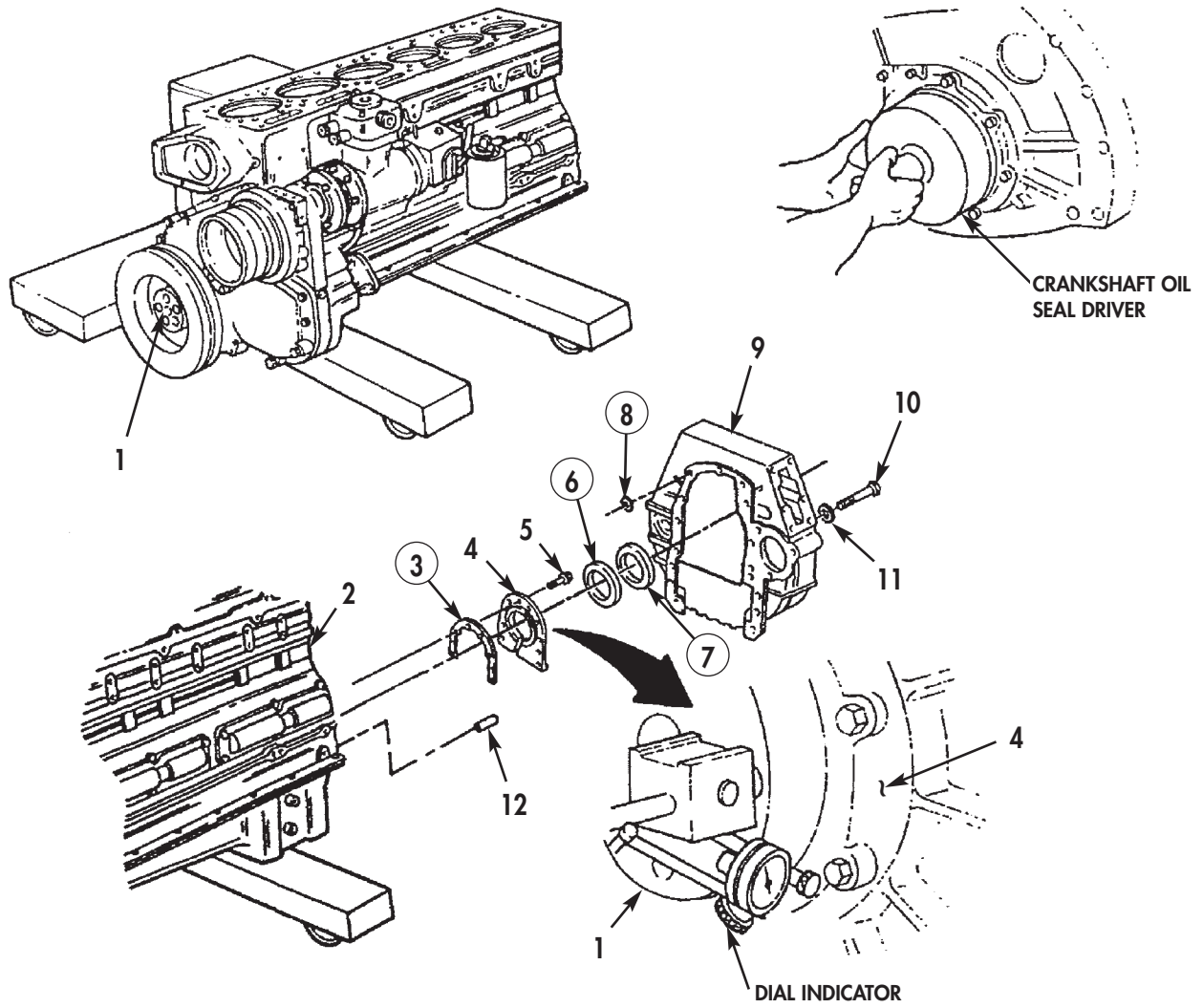


Figure 13. Flywheel Housing Installation.

CYLINDER BLOCK COMPONENTS INSTALLATION (Contd)

FLYWHEEL, FLEXPLATE, AND FLYWHEEL HOUSING (Contd)

12. Install dial gauge attachment and dial indicator on crankshaft (5).
13. Using chalk, mark flywheel housing (2) at 12, 3, 6, and 9 o'clock positions.

NOTE

If runout exceeds 0.008 in. (0.203 mm), move flywheel housing horizontally one-half distance of total indicator reading. Use prybars to move housing. If runout exceeds 0.008 in. (0.203 mm), move flywheel housing vertically one-half distance of total indicator reading. Use prybars to move housing. Total indicator reading must not exceed 0.008 in (0.203 mm). Adjust flywheel housing until within limit.

14. Check readings at 3 o'clock and 9 o'clock positions.
15. Check readings at 12 o'clock and 6 o'clock positions.
16. After readings are within limits, tighten screws (3) 140–160 lb-ft (190–217 N•m) in sequence shown in figure 14.
17. Adjust dial indicator to measure alignment of face on flywheel housing (2).
18. Push crankshaft toward front of cylinder block (1) to remove crankshaft end clearance.

NOTE

Ensure crankshaft is pushed toward front of cylinder block when checking alignment. Total indicator reading must not exceed 0.008 in. (0.203 mm). If alignment is not within limits, remove flywheel housing and check mating surfaces.

19. Rotate crankshaft (5) and check alignment of face on flywheel housing (2).
20. If dowel pins (4) were removed from cylinder block (1), use drill and fixture to ream dowel holes to next oversize and install two new dowel pins (4), if required.

CYLINDER BLOCK COMPONENTS INSTALLATION (Contd)

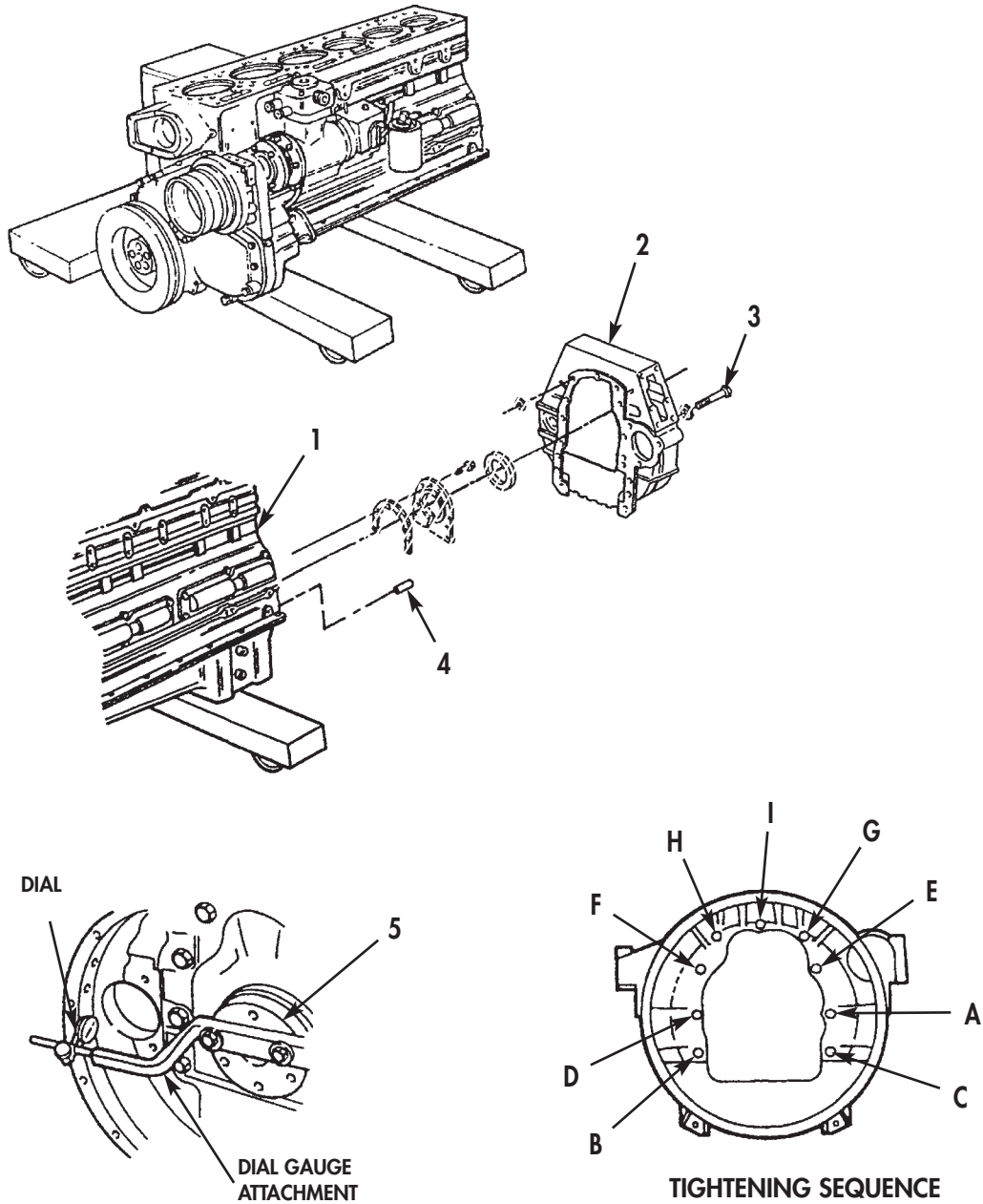


Figure 14. Flexplate Installation.

CYLINDER BLOCK COMPONENTS INSTALLATION (Contd)

FLYWHEEL, FLEXPLATE, AND FLYWHEEL HOUSING (Contd)

NOTE

Big Cam III engines are equipped with a flexplate-type flywheel with retaining plate and washer bearing.

Perform steps 21 and 22 for Big Cam III only.

21. Apply a thin coat of lubricating oil to threads of screws (7) and face of washers (6)
22. Install retaining plate (2), flexplates (3), flywheel (4), and washer bearing (5) on crankshaft (1) with six screws (7) and washers (6). Tighten screws (7) 200–220 lb-ft (271–298 N•m) in sequence shown in figure 15.

NOTE

Perform steps 23 through 27 for Big Cam I only.

23. Install two 5/8-18 x 6 in. guide studs in opposite holes on crankshaft (1) until fully seated.
24. Apply lubricating oil to threads of screws (11) and face of washers (10). Allow excess oil to drain from screw threads.
25. Install flywheel (9) and spacer gear (8) on crankshaft (1) with four screws (11) and washers (10). Tighten screws (11) hand-tight in sequence shown in figure 16.
26. Remove two 5/8-18 x 6 in. guide studs from crankshaft (1).
27. Install two remaining screws (11) and washers (10) on flywheel (9). Tighten screws (11) 70 lb-ft (95 N•m) then 140 lb-ft (190 N•m) and finally 200–220 lb-ft (271–298 N•m) in sequence shown in figure 16.

NOTE

The flywheel must be pushed toward front of engine to remove crankshaft end clearance when crankshaft is rotated and measurements are taken. If total indicator readings exceed limits, remove flywheel; clean flywheel and crankshaft flange faces, install, and repeat runout checks.

Perform steps 28 through 31 for Big Cam I only.

28. Install dial gauge attachment and dial indicator on flywheel housing (12).
29. Position contact tip of dial indicator against wide diameter of flywheel (9) bore and set dial indicator to zero. Rotate crankshaft (1) one complete revolution. Total indicator reading must not exceed 0.005 in. (0.127 mm).
30. Inspect flywheel (9) face runout and install or reposition dial indicator on flywheel housing (12).
31. Position contact tip of dial indicator against face of flywheel (9) as close to outside diameter as possible. Rotate crankshaft (1) one complete revolution. Total indicator reading must not exceed 0.005 in. (0.127 mm).

CYLINDER BLOCK COMPONENTS INSTALLATION (Contd)

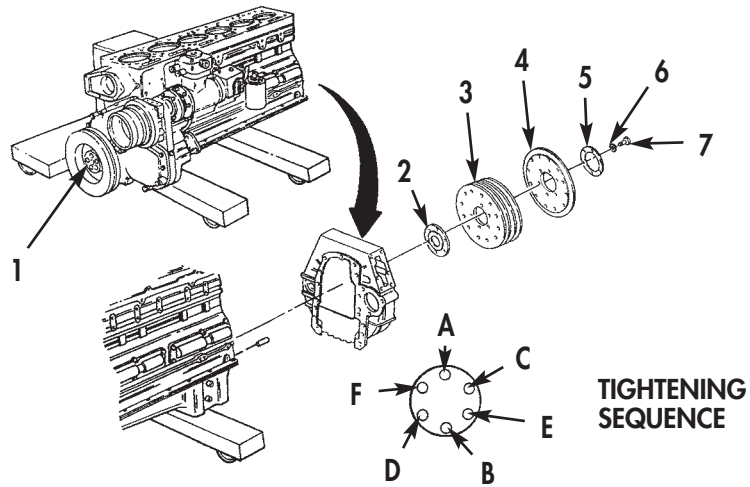


Figure 15. Flexplate Installation (Big Cam III).

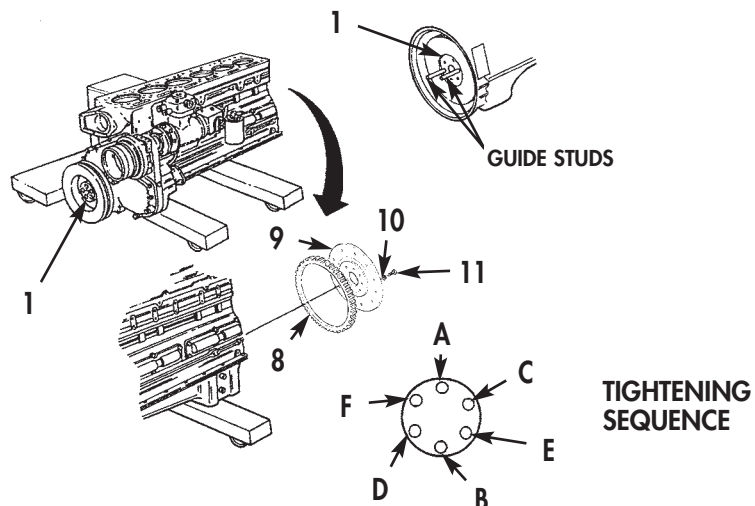


Figure 16. Flywheel Bolt Installation (Big Cam I).

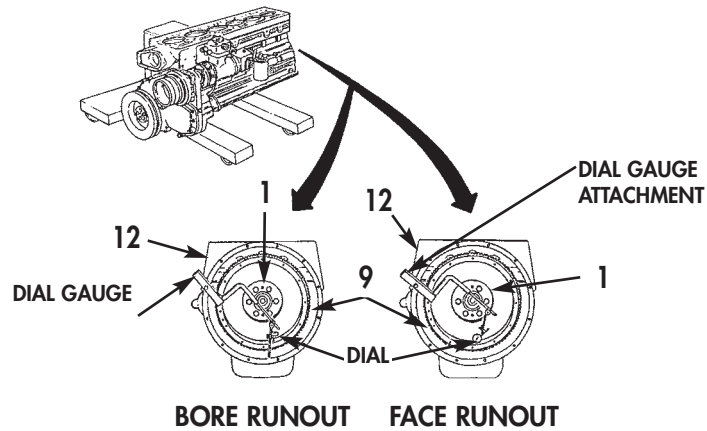


Figure 17. Measuring Flywheel Runout (Big Cam I).

CYLINDER BLOCK COMPONENTS INSTALLATION (Contd)**OIL PAN**

1. Apply a thin coat of GAA grease to oil pan (3) or (37) mounting surface.
2. Install new gasket (2) on cylinder block (1).
3. Position oil pan (3) or (37) on cylinder block (1).
4. Install twenty eight screws (12) on oil pan (3) or (37). Do not tighten screws (12) at this time.
5. Install four screws (6), new lockwashers (5), and washers (4) on oil pan (3) or (37). Do not tighten screws (6) at this time.
6. Install engine shipping support (15) on oil pan (3) or (37) with four screws (14) or (36). Do not tighten screws (14) or (36) at this time.

NOTE

Perform step 7 for Big Cam I only.

7. Install two screws (18) and washers (19) on middle holes of oil pan (37).
8. Finger-tighten two screws (12) on oil pan (3) or (37).

NOTE

Perform step 9 for Big Cam I only.

9. Remove two screws (18) and washers (19) from oil pan (37).
10. Finger-tighten four screws (12) on oil pan (3) or (37).
11. Tighten twenty-eight screws (12) and four screws (14) or (36) 35–40 lb-ft (41–48 N•m).

NOTE

Perform steps 12 through 14 for Big Cam I only.

12. Install four screws (18) and washers (19) on oil pan (37). Do not tighten screws (18) at this time.
13. Install two screws (21), four washers (22), new lockwashers (23), and nuts (24) on oil pan (37). Do not tighten screws (21) at this time.
14. Tighten four screws (18) and two nuts (24) 70–80 lb-ft (95–109 N•m).
15. Tighten screws (6) 15–20 lb-ft (20–27 N•m).

NOTE

Perform steps 16 and 17 for Big Cam III only.

16. Install new gasket (17), and two new O-rings (11) on oil suction tube (10). Position oil suction tube (10) on oil pan (3) and oil pump (16).
17. Install oil suction tube (10) on oil pan (3) and oil pump (16) with two screws (7), screws (13), four new lockwashers (8), and washers (9). Tighten screws (7) 30–35 lb-ft (41–48 N•m). Tighten screws (13) 30–35 lb-ft (41–48 N•m).

NOTE

Perform steps 18 through 26 for Big Cam I only.

18. Install oil suction hose (25) and new gasket (17) on oil pan (37) with screws (26) and new lockwashers (27). Do not tighten screws (26) at this time.
19. Install adapter (35) and oil suction hose (25) on oil pump (16) and hand-tighten oil suction hose (25) nut until snug, then tighten oil suction hose (25) nut and additional 1 to 1 ¼ turn.
20. Tighten two screws (26) 30–35 lb-ft (41–48 N•m).

CYLINDER BLOCK COMPONENTS INSTALLATION (Contd)

OIL PAN (Contd)

21. Tighten nut on oil suction hose (25) mounting flange until nut is against stop on mounting flange.
22. Remove one screw (12) from left side of oil pan (37).
23. Install bracket (31) on oil pan (37) with screw (32) and new lockwasher (33). Tighten screw (32) 35–40 lb-ft (41–48 N•m).
24. Position clamp (29) on oil suction hose (25).
25. Position spacer (30) between bracket (31) and clamp (29).
26. Install screw (28), new lockwasher (8), washer (9), and nut (34) on bracket (31). Tighten screw (28).

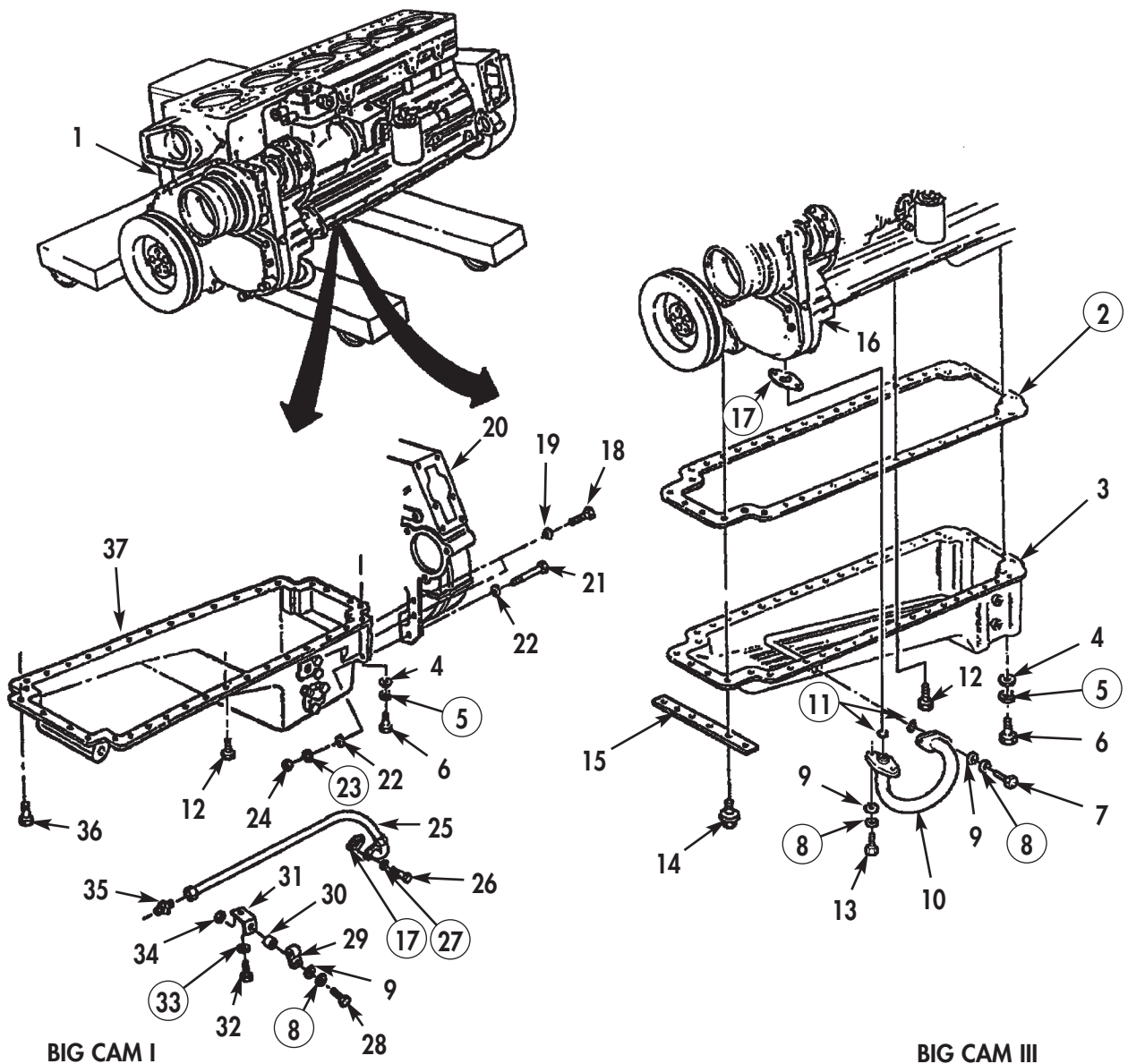


Figure 18. Oil Pan Installation.

END OF WORK PACKAGE

**DIRECT SUPPORT AND GENERAL SUPPORT
MAINTENANCE MANUAL
INCLUDING REPAIR PARTS AND SPECIAL TOOLS LIST (RPSTL)**

FOR

M915, M915A1, M915A4, M916, M920 VEHICLES

NSN 2815-01-082-8125	P/N NTC400-3652-02	CUMMINS NTC-400 BIG CAM I DIESEL ENGINE W/CONTAINER
NSN 2815-01-142-2745	P/N 11669835	CUMMINS NTC-400 BIG CAM III DIESEL ENGINE W/CONTAINER

CYLINDER HEAD AND CYLINDER HEAD COMPONENTS INSTALLATION

CYLINDER HEAD, FUEL INJECTOR, ROCKER ARM HOUSING, ENGINE BRAKE RETARDER, ROCKER COVER

INITIAL SETUP:

Tools and Special Tools

General mechanic's tool kit: automotive
(Item 1, WP 0061 00)
Maintenance and repair shop equipment:
automotive (Item 2, WP 0061 00)
Automotive maintenance and repair
supplemental set no. 2 (Item 3, WP 0061 00)
Fuel injector puller (Item 8, WP 0061 00)

Equipment Condition

Engine mounted on maintenance stand
(WP 0009 00).

Material/Parts

Twelve O-rings (Item 1, Table 26, WP 0062 00)
Three cylinder head gaskets
(Item 2, Table 26, WP 0062 00)
Three gaskets (Item 3, Table 26, WP 0062 00)
Three gaskets (Item 4, Table 26, WP 0062 00)
Three gaskets (Item 5, Table 26, WP 0062 00)
Eighteen O-rings
(Item 6, Table 26, WP 0062 00)
Rust preventative lubricant
(Item 16, WP 0060 00)
OE/HDO 10 lubricating oil
(Item 19, WP 0060 00)
60-80/140 lubricating oil
(Item 21, WP 0060 00)

CYLINDER HEAD AND CYLINDER HEAD COMPONENTS INSTALLATION (Contd)

CYLINDER HEAD

NOTE

The following procedure covers installation of one cylinder head assembly. Installation of remaining cylinder heads is similar. Perform steps 1 through 10 to install each additional cylinder head assembly as required.

Ensure marks made on each cylinder head and cylinder block during removal are matched together during installation so that each cylinder head assembly is installed in its original position on cylinder block.

Ensure new cylinder head gasket has the side with word TOP facing upwards.

1. Install new cylinder head gasket (7) on cylinder head (5).
2. Install cylinder head (5) on cylinder block (6).
3. Apply rust preventative lubricant to twelve screws (4). Allow excess lubricant to drip from screw threads before installation.
4. Install twelve screws (4) and washers (3) on cylinder head (5). Tighten screws (4) 25 lb-ft (34 N•m) in sequence shown in figure 1.
5. Tighten screws (4) 100 lb-ft (136 N•m) in sequence shown in figure 1.

NOTE

Perform step 6 for Big Cam I only.

6. Tighten screws (4) 305 lb-ft (414 N•m) in sequence shown in figure 1.

NOTE

Perform step 7 for Big Cam III only.

7. Tighten screws (4) 285 lb-ft (387 N•m) in sequence shown in figure 1.
8. Apply OE/HDO 10 lubricating oil to four new O-rings (8).
9. Install O-rings (8) on counterbores of cylinder head (5).
10. Install two fuel crossover connections (1) on cylinder head (5) with four screws (2). Tighten screws (2) 38 lb-in (4.3 N•m).

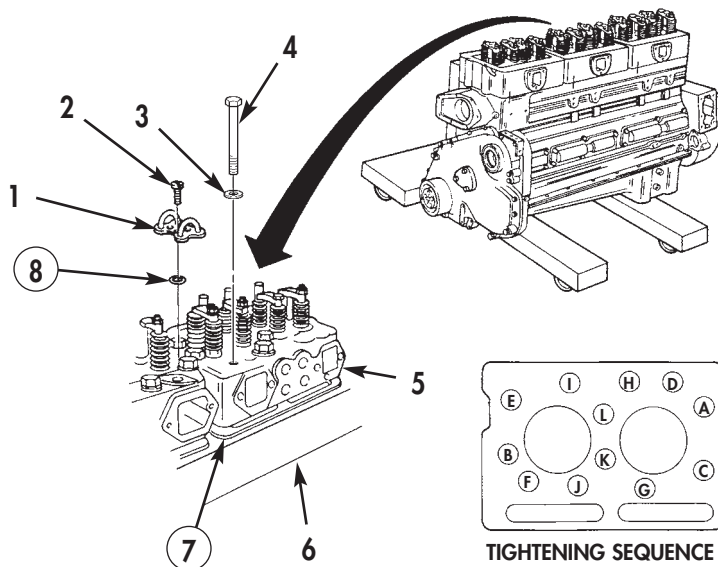


Figure 1. Cylinder Head Installation.

CYLINDER HEAD AND CYLINDER HEAD COMPONENTS INSTALLATION (Contd)

FUEL INJECTOR

CAUTION

If injector assembly fails to seat completely, remove and check for a twisted or damaged O-ring. Failure to comply may result in damage to equipment.

NOTE

Inspect fuel cooling sleeve in cylinder head prior to installing injector. Remove any dirt with a lint-free cloth.

The following procedure covers installation of one injector assembly. Installation of remaining five injectors are similar.

Ensure injectors are installed in same location as noted during removal.

1. Apply OE/HDO 10 lubricating oil to three new O-rings (12) and fuel injector (13).
2. Using injector puller, install fuel injector (13) in cylinder head (5).
3. Install retaining plate (11) on fuel injector (13) with two screws (9). Do not tighten screws.
4. Install detent plunger (10) on fuel injector (13).

NOTE

Check for free movement of detent plunger after tightening screws. If detent plunger does not move freely, loosen two screws and retighten. Detent plunger must move freely.

5. Tighten screws (9) in steps of 5 lb-ft (7 N•m) until a final torque of 12 lb-ft (16 N•m) is obtained.

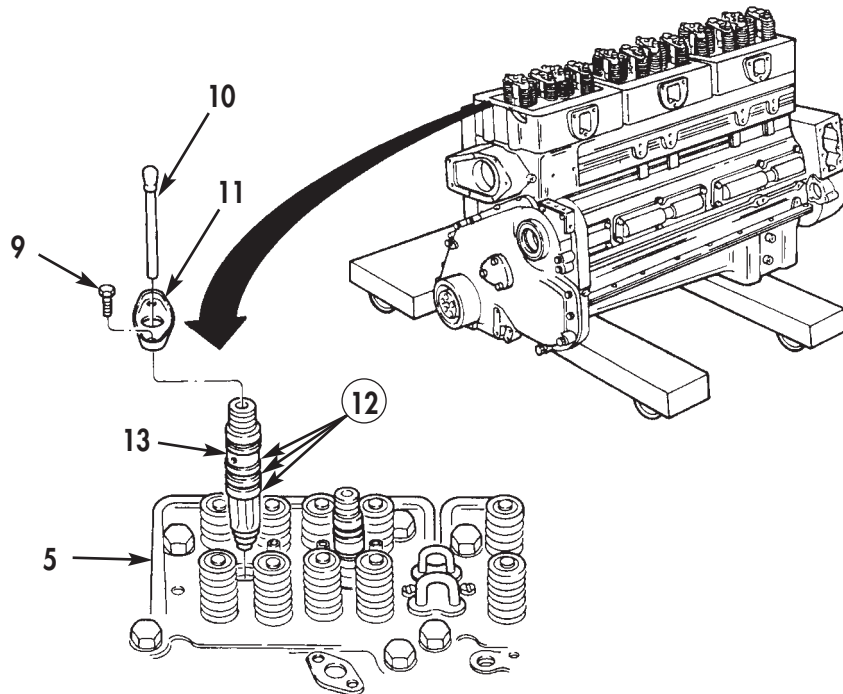


Figure 2. Fuel Injector Installation.

CYLINDER HEAD AND CYLINDER HEAD COMPONENTS INSTALLATION (Contd)

ROCKER ARM HOUSING

NOTE

The following procedure covers the installation of one rocker arm housing assembly. The installation of the remaining rocker arm housing assemblies is similar.

1. Install new gasket (6) on cylinder head (5).
2. Loosen six adjusting screws (2) three complete turns.
3. Apply GO-80/140 lubricating oil to ball ends of four intake and exhaust pushrods (4) and two injector pushrods (3).

NOTE

The injector pushrods are larger in diameter than the valve pushrods. The valve pushrods are 0.007 in. (0.178 mm) longer than injector pushrods.

Ensure each pushrod is installed in same position as noted during removal.

Ball end of pushrods must fit into socket of cam followers. The injector pushrod is installed on center injector cam follower.

4. Install four intake and exhaust pushrods (4) and two injector pushrods (3) on cam followers of cylinder head (5).

NOTE

Position six rocker levers so ball end of adjusting screw drops into sockets of six pushrods.

5. Install rocker arm housing (7) on cylinder head (5).
6. Install six new washer bearings (8) on rocker arm housing (7).

NOTE

There are three different sizes of rocker housing studs. Install correct rocker housing stud in correct rocker arm housing. Damage to rocker housing stud threads may result if substitution of length is made.

7. Install six rocker housing studs (1), (9), and (10) on rocker housings (7) as shown in figure 3. Tighten studs (1), (9), and (10) 65 lb-ft (68 N•m) in sequence shown in figure 3.

CYLINDER HEAD AND CYLINDER HEAD COMPONENTS INSTALLATION (Contd)

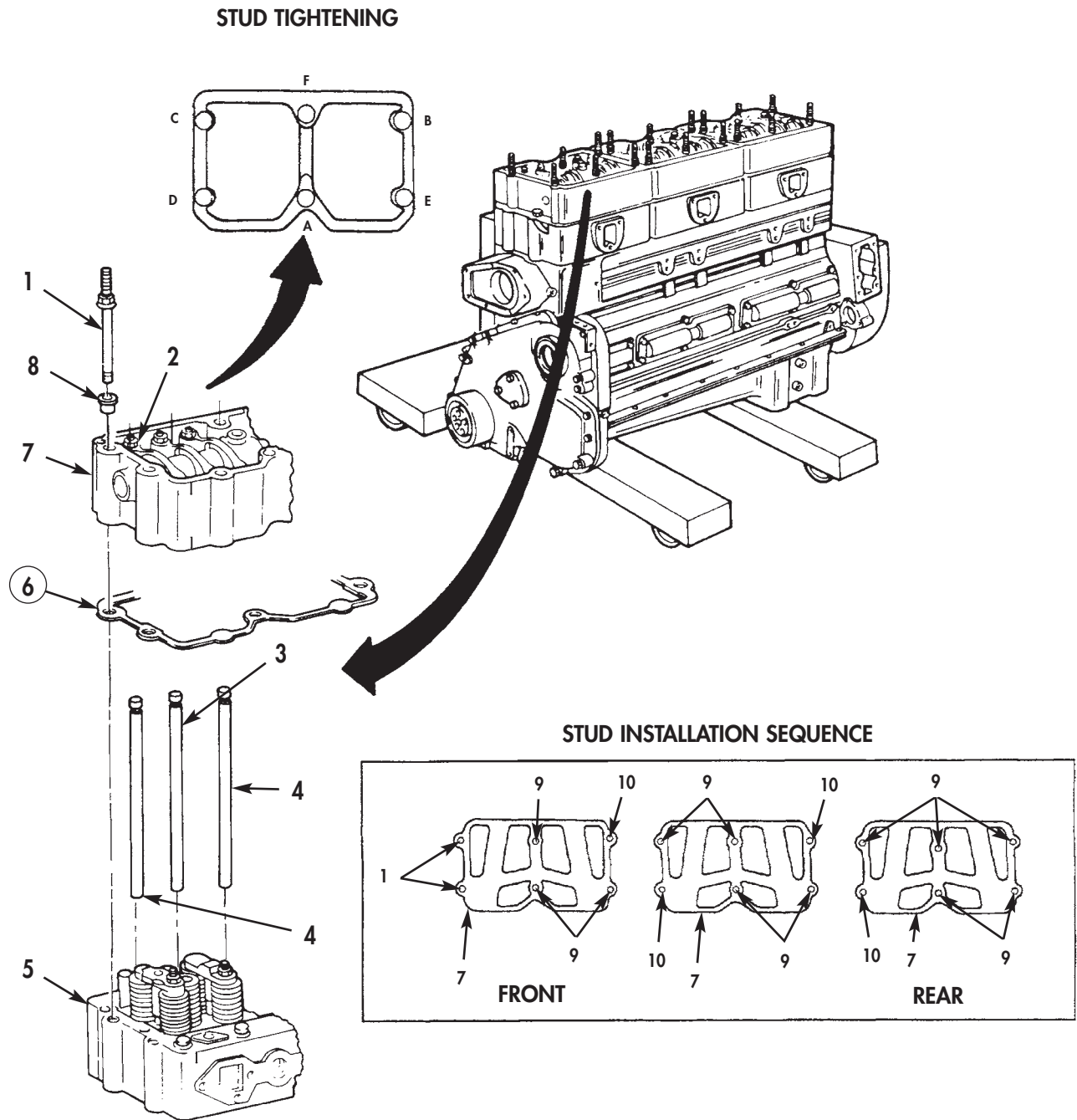


Figure 3. Rocker Arm Housing Installation.

CYLINDER HEAD AND CYLINDER HEAD COMPONENTS INSTALLATION (Contd)

ROCKER ARM HOUSING (Contd)

NOTE

Engine cylinders are numbered in sequence, starting at front with No. 1 cylinder. The engine firing order is 1-5-3-6-2-4.

Valves and injectors for the same cylinder are not adjusted at same index mark on accessory drive pulley. One pair of valves from one cylinder and one injector on a different cylinder are adjusted at each pulley index mark before rotating accessory drive to next index mark.

Two crankshaft revolutions are required to adjust all valves and injectors.

8. Using medium grit emery cloth, remove paint on timing marks (2), (3), and (4) on accessory drive pulley (1).
9. Rotate accessory drive pulley (1) clockwise until line in front of timing mark (2) aligns with pointer (6) on front gear cover (5).

NOTE

Steps 10 through 16 covers adjustment for cylinder No. 3.

10. Loosen adjusting screw nut (8) several turns.
11. Tighten adjusting screw (9) until all clearance is removed between rocker lever (10) and injector detent plunger.
12. Tighten adjusting screw (9) one additional turn.
13. Loosen adjusting screw (9) one complete turn until spring washer inside injector is against stop of injector.
14. Tighten adjusting screw (9) 5–6 lb-in (0.6–0.7 N•m).
15. Repeat step 14 several times to make certain adjusting screw (9) is correctly tightened.

NOTE

If torque driver ST-669 is used, tighten adjusting screw nut 35 lb-ft (48 N•m).

16. Prevent adjusting screw (9) from turning and tighten adjusting screw nut (8) 45 lb-ft (61 N•m).

NOTE

Adjustment for intake valve is similar to exhaust valve except for valve clearance difference.

Steps 17 through 20 covers intake and exhaust valve adjustment for cylinder No. 5.

17. Loosen adjusting screw nut (8).

NOTE

Cold valve clearance for exhaust valve is 0.023 in. (0.584 mm) and valve clearance for intake valve is 0.011 in. (0.279 mm).

18. Place feeler gauge between rocker lever (10) and crosshead (11).
19. Slowly tighten screw (9) until rocker lever (10) touches feeler gauge.

CYLINDER HEAD AND CYLINDER HEAD COMPONENTS INSTALLATION (Contd)

ROCKER ARM HOUSING (Contd)

NOTE

If torque driver ST-669 is used, tighten adjusting screw nut 40 lb-ft (54 N•m).

20. Hold adjusting screw (9) in place and tighten adjusting screw nut (8) 45 lb-ft (61 N•m).
21. Slowly rotate accessory drive pulley (1) clockwise until line in front of timing mark (3) aligns with pointer (6) on front gear cover (5).
22. Perform steps 10 through 16 for cylinder No. 6 injector.
23. Perform steps 17 through 20 for cylinder No. 3 intake and exhaust valves.
24. Slowly rotate accessory drive pulley (1) clockwise until line in front of timing mark (4) aligns with pointer (6) on front gear cover (5).
25. Perform steps 10 through 16 for cylinder No. 2 injector.
26. Perform steps 17 through 20 for cylinder No. 6 intake and exhaust valves.
27. Slowly rotate accessory drive pulley (1) clockwise until line in front of timing mark (2) aligns with pointer (6) on front gear cover (5).
28. Perform steps 10 through 16 for cylinder No. 4 injector.
29. Perform steps 17 through 20 for cylinder No. 2 intake and exhaust valves.
30. Slowly rotate accessory drive pulley (1) clockwise until line in front of timing mark (3) aligns with pointer (6) on front gear cover (5).
31. Perform steps 10 through 16 for cylinder No. 1 injector.
32. Perform steps 17 through 20 for cylinder No. 4 intake and exhaust valves.
33. Slowly rotate accessory drive pulley (1) clockwise until line in front of timing mark (4) aligns with pointer (6) on front gear cover (5).
34. Perform steps 10 through 16 for cylinder No. 5 injector.
35. Perform steps 17 through 20 for cylinder No. 1 intake and exhaust valves.

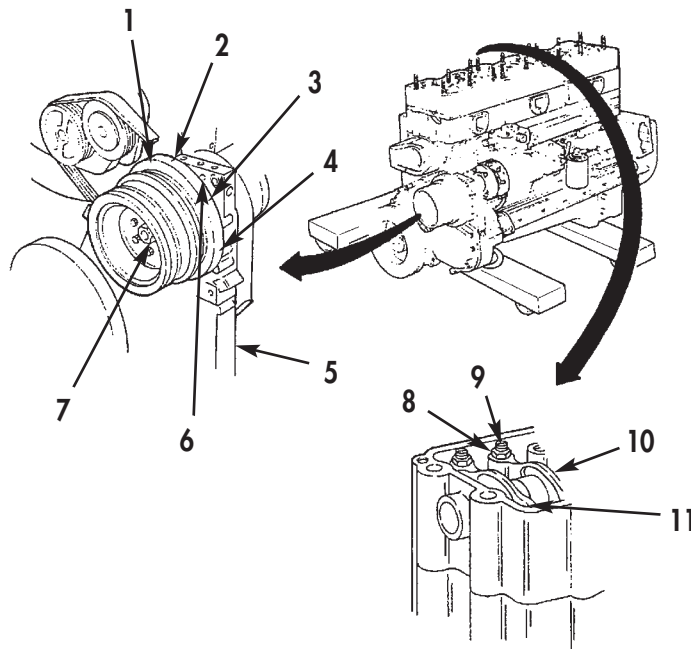


Figure 4. Injector Timing.

CYLINDER HEAD AND CYLINDER HEAD COMPONENTS INSTALLATION (Contd)

ENGINE BRAKE RETARDER

NOTE

The following procedure covers installation of one engine brake retarder. Installation of remaining engine brake retarders are similar.

1. Install new gasket (11) on rocker arm housing (13).
2. Install engine brake retarder (3) on two rocker arm housing studs (14).
3. Install fan bracket (1) and two spacers (5) on two rocker housing studs (14).
4. Install six nuts (2) on rocker housing studs (14). Tighten nuts (2) 60 lb-ft (81 N•m) in sequence shown in figure 4.

NOTE

The following procedure covers adjustment for one slave piston. There are two slave pistons per brake retarder, or one per cylinder. The adjustment for the remaining five slave pistons is similar. Ensure locknuts are loose before adjusting setscrew.

The adjustment procedure for slave piston requires engine crankshaft to be rotated and accessory drive pulley assembly positioned on timing mark A, B, or C. When positioned at timing mark A, cylinders No. 5 or 2 can be adjusted. When positioned at timing mark B, cylinders No. 3 or 4 can be adjusted. When positioned at timing mark C, cylinders No. 6 or 1 can be adjusted.

5. Loosen locknut (8) and setscrew (9) until there is no pressure or tension.
6. Using feeler gauge, check slave piston (12) clearance between slave piston (12) and crosshead (4). Adjust clearance to 0.018 in. (0.457 mm).

CAUTION

After slave piston adjusting screw locknut has been tightened to specified value, check clearance with feeler gauge again. Do not overtighten adjusting screw locknut or clearance may change and result in damage to engine.

7. Tighten locknut (8) 40 lb-ft (54 N•m).
8. Using feeler gauge, recheck slave piston (12) clearance.
9. Connect spade end of solenoid harness (7) to solenoid valve (6).
10. Connect receiver end of solenoid harness (7) to terminal (10) inside engine brake retarder (3).

CYLINDER HEAD AND CYLINDER HEAD COMPONENTS INSTALLATION (Contd)

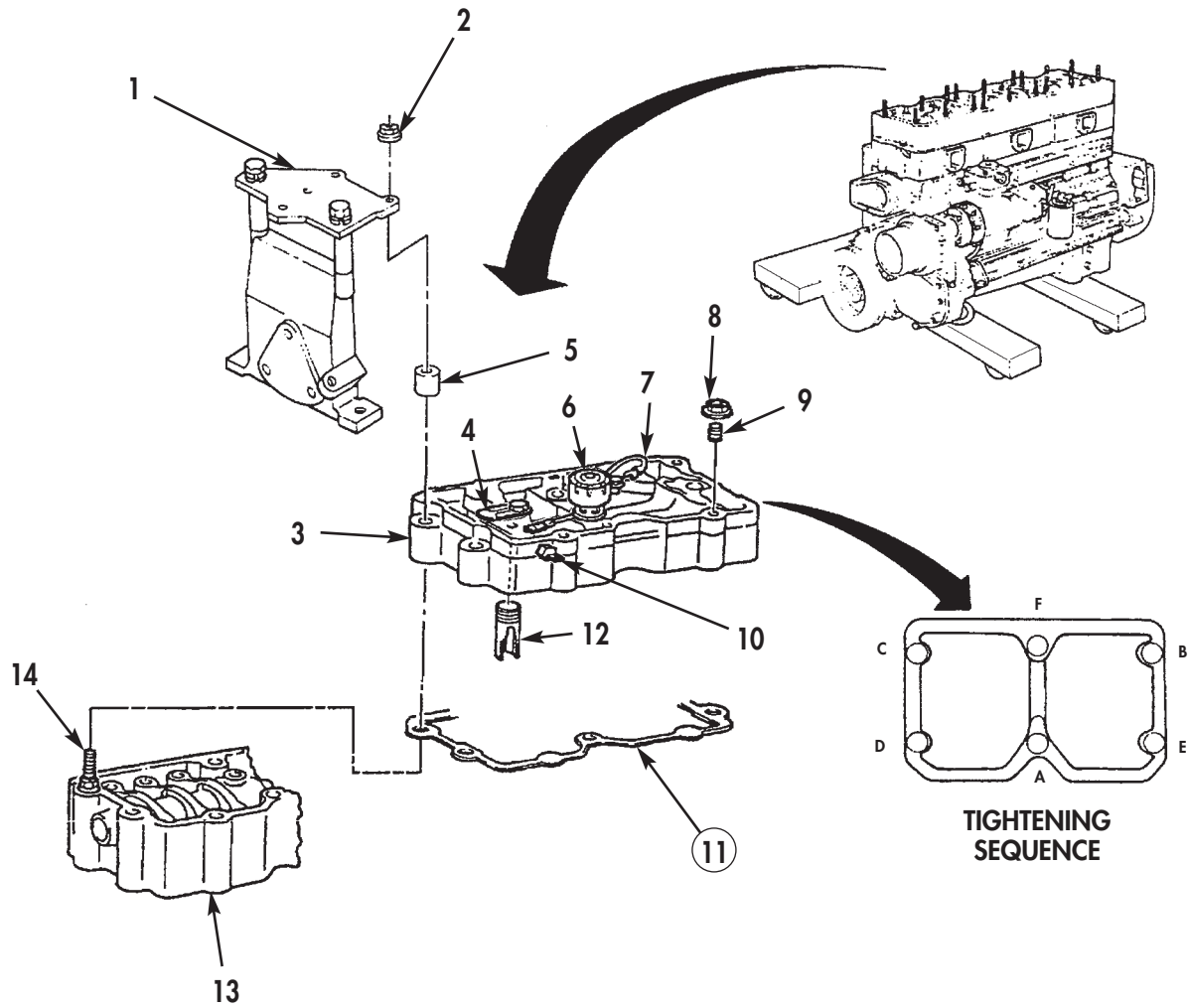


Figure 5. Engine Brake Retarder Installation.

CYLINDER HEAD AND CYLINDER HEAD COMPONENTS INSTALLATION (Contd)

ROCKER COVER

NOTE

This procedure covers installation of one rocker cover. All three rocker covers are installed the same.

Install new gasket (3) and rocker cover (2) on engine brake retarder (4) with five screws (1). Tighten screws (1) 12–17 lb-ft (16–23 N•m).

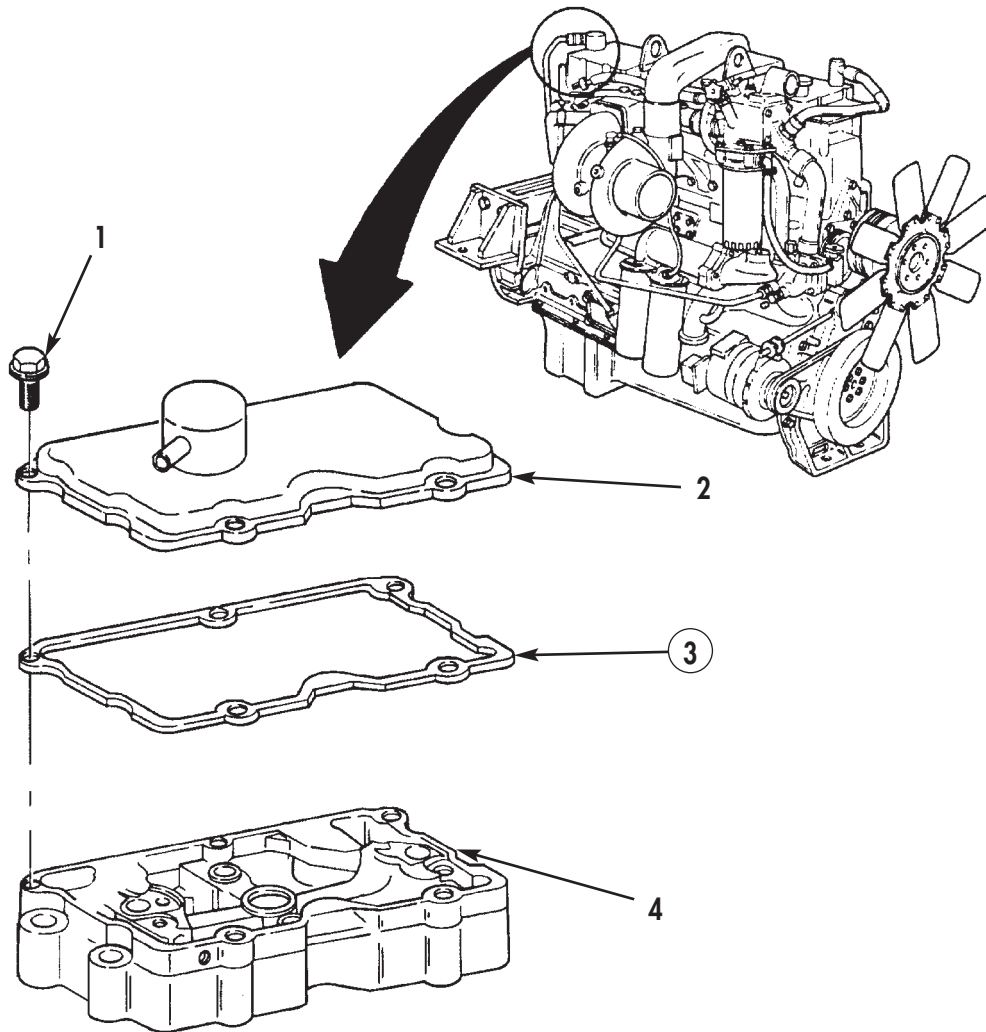


Figure 6. Rocker Cover Installation.

END OF WORK PACKAGE

**DIRECT SUPPORT AND GENERAL SUPPORT
MAINTENANCE MANUAL
INCLUDING REPAIR PARTS AND SPECIAL TOOLS LIST (RPSTL)**

FOR

M915, M915A1, M915A4, M916, M920 VEHICLES

NSN 2815-01-082-8125	P/N NTC400-3652-02	CUMMINS NTC-400 BIG CAM I DIESEL ENGINE W/CONTAINER
NSN 2815-01-142-2745	P/N 11669835	CUMMINS NTC-400 BIG CAM III DIESEL ENGINE W/CONTAINER

FUEL PUMP TESTING AND CALIBRATION

**PREADJUSTMENT CHECKS, IDLE SPEED ADJUSTMENT, HIGH-SPEED ADJUSTMENT,
CHECKING AND ADJUSTING FUEL RAIL, CHECKING AND ADJUSTING ENGINE FUEL,
CHECKING AND ADJUSTING THROTTLE LEAKAGE, CHECKING FUEL FILTER RESTRICTION,
FUEL PUMP SEAL INSTALLATION, THROTTLE SHAFT COVER PLATE INSTALLATION**

INITIAL SETUP:

Tools and Special Tools

General mechanic's tool kit: automotive
(Item 1, WP 0061 00)
Maintenance and repair shop equipment,
automotive (Item 2, WP 0061 00)
Automotive maintenance and repair
supplemental set no. 2 (Item 3, WP 0061 00)
Fuel pump idle adjusting tool
(Item 60, WP 0061 00)
Throttle shaft ball installing tool
(Item 61, WP 0061 00)

Materials/Parts

Snapring (Item 1, Table 27, WP 0062 00)
Gasket (Item 2, Table 27, WP 0062 00)
Throttle shaft cover plate
(Item 3, Table 27, WP 0062 00)

FUEL PUMP TESTING AND CALIBRATION (Contd)

WARNING

Allow adequate ventilation for engine exhaust gases. Do not perform fuel system procedures while smoking or within 50 ft (15.2 m) of sparks or open flame. Diesel fuel is flammable and may explode. Failure to comply may result in serious injury or death to personnel.

PREADJUSTMENT CHECKS

CAUTION

Do not alter pump settings to match gauges and tachometers of unknown accuracy. Failure to comply may result in damage to equipment.

NOTE

Vehicle fuel control lever and throttle stop linkage should have a maximum throttle stop, so when fuel pump full throttle is obtained, override pressure will not be on throttle shaft.

After proper calibration, fuel pump should require very little adjustment. Some adjustment may be required at idle, since this setting is dependent on parasitic loads. Fine adjustment of governor settings and fuel manifold pressure is permissible within the limits specified if justified by engine performance tests.

Check and adjust throttle control linkage for full throttle operation and throttle released operation with the throttle stopped by the throttle leakage adjusting screw.

IDLE SPEED ADJUSTMENT

NOTE

Idle speed adjustment should never be made on a cold engine. Engine must be operated for sufficient time to purge all air from the fuel system and to bring the engine up to operating temperature (at least 165° F (74° C) oil temperature).

1. Remove plug (7) from spring pack cover (9) and start engine (1) on dynamometer (2).

NOTE

Fuel pump idle adjusting tool will not let the spring pack cover leak when the idle is adjusted.

2. Turn idle adjusting screw (16) in to increase engine rpm, out to decrease rpm.
3. Using idle adjusting tool (4), set idle to 600 +/- 2 rpm.
4. Install plug (7) on spring pack cover (9).

FUEL PUMP TESTING AND CALIBRATION (Contd)

HIGH-SPEED ADJUSTMENT

1. Remove spring pack cover (9), three captive washer screws (6), screw (8), and four washers (5) from fuel pump (3).
2. Remove fuel pump gasket (10) from fuel pump (3). Discard gasket (10).
3. Remove snpring (11) from fuel pump (3). Discard snpring (11).
4. Remove spring retainer (12) from fuel pump (3).

NOTE

Each 0.0001 in. (0.025 mm) shim thickness will change speed approximately 2 rpm.

5. Add or remove shims (13) behind spring (14). High-speed adjustment should be 2130 to 2150 rpm.
6. Install spring retainer (12) and new snpring (11) on guide (15).
7. Install spring pack cover (9) and new gasket (10) on fuel pump (3) with three captive washer screws (6), screw (8), and four washers (5). Tighten screws (6) and (8) 9–11 lb-ft (12–15 N•m).

NOTE

Do not use this check to make governor speed adjustments. If no-load speed is much greater than specifications, examine governor for malfunction or faulty parts.

8. Operate engine (1) to purge air from fuel system and bring up to operating temperature.
9. Bring engine (1) to full throttle and hold. Note maximum rpm. Speed should be 10–12 percent greater than governor speed cutoff point.

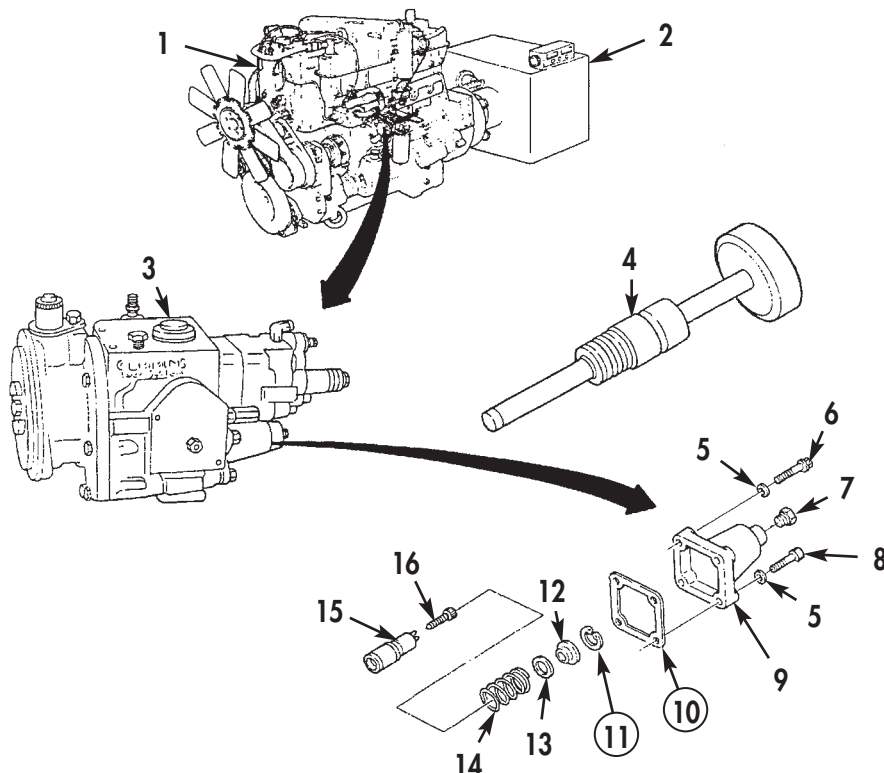


Figure 1. Idle Speed Adjustment.

FUEL PUMP TESTING AND CALIBRATION (Contd)

CHECKING AND ADJUSTING FUEL RAIL

NOTE

It should not be necessary to adjust fuel rail pressure on a newly calibrated fuel pump more than +/- 2 psi (+/- 14 kPa). If adjustments greater than this are required, fuel pump test stand, injector test stand, or engine problems may exist. Do not remove throttle shaft ball unless fuel rail pressure adjustment needs to be performed.

The correct method of checking engine fuel rail pressure is with engine installed on a chassis or engine dynamometer.

1. Check governor speed cutoff and adjust if necessary.
2. Install fuel rail pressure gauge (4) between fuel supply elbow (11) on fuel pump assembly (10) and female union tee (12).
3. Bring engine (3) to full throttle load until rpm falls to rated speed.
4. Note fuel rail pressure gauge (4) reading. If pressure is above or below 83 psi, perform steps 5–8.

CAUTION

Do not turn threaded stud out beyond maximum throttle travel. The fuel hole in the throttle shaft will begin to close. Never adjust fuel rail pressure above maximum specifications. This will void engine warranty and violate Environmental Protection Agency (EPA) requirements.

5. Turn threaded stud (9) out to obtain maximum throttle travel and secure with jamnut (8).
6. Remove throttle shaft ball (5) from throttle shaft (6).

NOTE

It should not be necessary to adjust fuel manifold pressure on a newly calibrated pump more than +/- 2 psi (+/- 14 kPa). If adjustments greater than these are required, fuel pump test, injector test stand, or engine problems may exist.

7. Turn fuel adjusting screw (7) in throttle shaft (6) in to increase or out to decrease pressure while watching fuel rail pressure gauge (4).
8. Using throttle shaft ball installing tool (1), install throttle shaft ball (5) into end of throttle shaft (6).

FUEL PUMP TESTING AND CALIBRATION (Contd)

CHECKING AND ADJUSTING ENGINE FUEL

1. Connect fuel pump (10) to fuel rate meter (2).
2. Bring engine (3) to full throttle and increase dynamometer load until engine rpm falls to rated speed.
3. Check governor speed cut-off while load is on engine (3).
4. Check fuel rail pressure gauge (4) at maximum speed.
5. Hold engine speed and load at maximum speed long enough for fuel rate meter (2) to stabilize.

NOTE

The fuel rate specified on fuel pump calibration specification is at full throttle and rated speed. An engine or chassis dynamometer must be used. Accurate fuel rail pressure and speed readings must also be taken.

6. Verify correct fuel rate measurement with fuel rate meter (2).

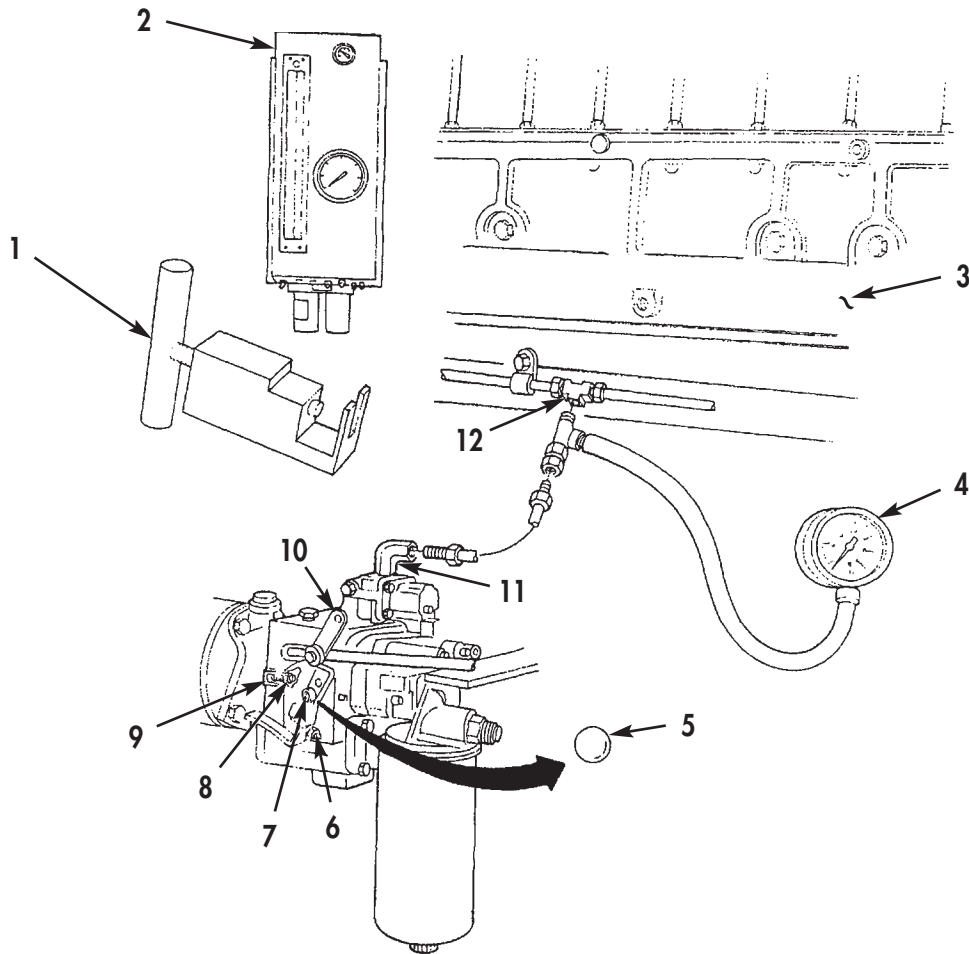


Figure 2. Fuel Adjustment.

FUEL PUMP TESTING AND CALIBRATION (Contd)

CHECKING AND ADJUSTING THROTTLE LEAKAGE

NOTE

If throttle leakage is adjusted correctly on fuel pump test stand, fuel pump will not need to be adjusted on engine. Vehicle throttle linkage must be adjusted so that threaded stud of throttle leakage adjusting screw (rear screw) just contacts stop in pump throttle.

The purpose of the throttle leakage is to keep the fuel lines and injector drilling full of fuel during closed throttle operation. The correct throttle leakage will help acceleration when the throttle is opened after going down a grade. Throttle leakage will also prevent stalling when it slows down to the idle speed. Too much leakage will cause slow deceleration.

1. Bring engine (1) to full throttle and allow engine (1) to run at maximum no-load speed.
2. Release or move throttle quickly and start a suitable timer or stopwatch at the same time.
3. Stop timer when 1000 rpm is reached and check deceleration time. Repeat this check several times.
4. Increase leakage as engine (1) begins to stall (idle governor does catch engine after deceleration from high idle) by turning in threaded stud (3).
5. Recheck engine (1) deceleration until time is increased 1-2 seconds.
6. Lock threaded stud (3) with jamnut (2).
7. Recheck idle speed and readjust as necessary.
8. Bring engine to 1000 rpm.

FUEL PUMP TESTING AND CALIBRATION (Contd)

CHECKING AND ADJUSTING THROTTLE LEAKAGE (Contd)

9. Check deceleration time when engine (1) is shut down.
10. Decrease leakage by turning threaded stud (3) out until engine (1) tends to stall after deceleration to high idle.
11. Turn in threaded stud (3) until deceleration is increased 1-2 seconds. Lock threaded stud (3) with jamnut (2).
12. Recheck idle speed and readjust as necessary.

NOTE

Engine power cannot be set accurately in any other way except on engine dynamometer. Fuel pump adjustments must not be made on an engine when the engine power comes from an estimate. Before any adjustments on the fuel pump are made, the following engine performance data must be checked so that adjustments are justified.

13. Check fuel rail pressure, fuel rate, speed setting, smoke, coolant temperature, combustion smoothness, exhaust restriction, fuel quality, air intake restriction, engine oil level, and engine power reducing factors.
14. Check engine power by rechecking setting point of governor speed cutoff and readjust if necessary.

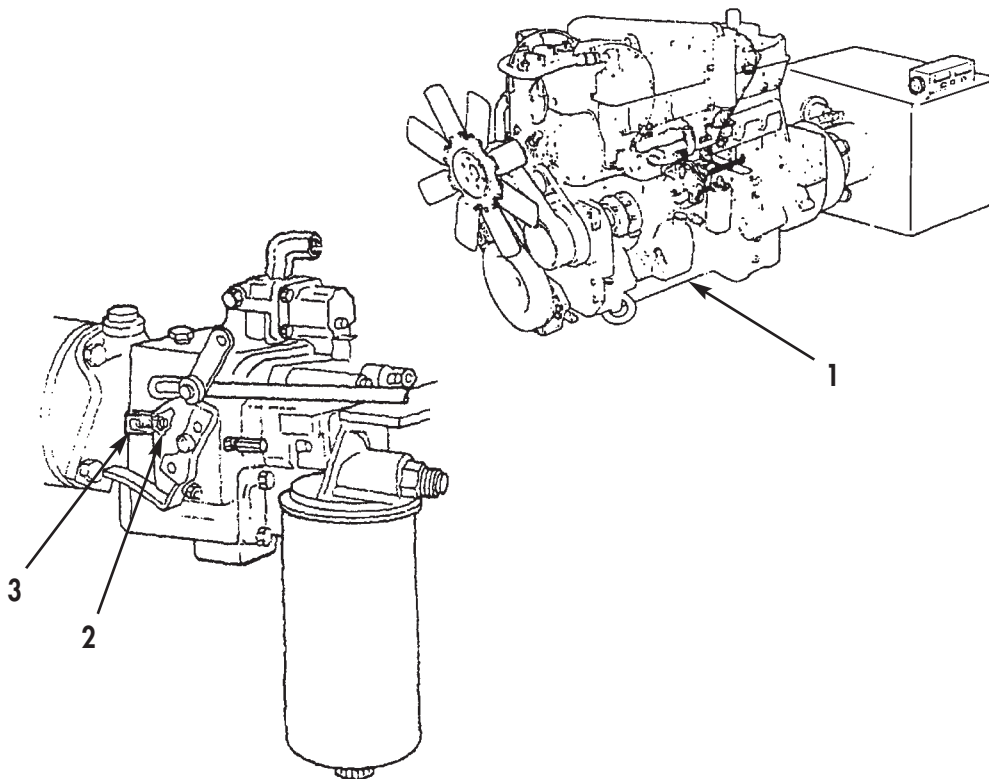


Figure 3. Checking and Adjusting Throttle Leakage.

FUEL PUMP TESTING AND CALIBRATION (Contd)

CHECKING FUEL FILTER RESTRICTION

1. Connect vacuum gauge (3) to fuel inlet (4) on fuel damper (5).
2. Bring engine (1) to full throttle and full load on dynamometer (2) and check vacuum gauge (3).
3. If restriction reads 8 in. (20.3 cm) of vacuum while engine is running at full throttle and full load, change fuel filter and check other sources of restriction.
4. Use sight glass to check for moving bubbles and possible gasket or other leaks. If air bubbles are still seen, check float valve in float tank used for test. Fuel pump may be pumping more fuel than float valve will allow to pass into the float tank.

FUEL PUMP SEAL INSTALLATION

NOTE

Fuel pump must be sealed after final adjustments are made to prevent tampering.

1. Using lockwire and seal (8), insert lockwire through screw (12), plug (11), and threaded stud (14) on spring pack cover (13).
2. Twist lockwires together until connection is secure and lockwire is tight.
3. Bend twisted lockwire into seal and press on top half of seal.
4. Using lockwire and seal (8), insert lockwire through screw (10), drilled fillister head screw (9), and captive washer screw (7).
5. Twist lockwires together until connection is secure and lockwire is tight.
6. Bend twisted lockwire into seal and press on top half of seal.

THROTTLE SHAFT COVER PLATE INSTALLATION

NOTE

Use etching tool or steel stamp and imprint date of repair on backside of throttle shaft cover plate (6) for future reference.

1. Position new throttle shaft cover plate (6) on housing (16).
2. Drill two new holes on opposite sides of throttle shaft cover plate (6) 0.235 in. (5.969 mm) into pump housing (16).
3. Secure new throttle shaft cover plate (6) on housing (16) with two drive screws (15).

FUEL PUMP TESTING AND CALIBRATION (Contd)

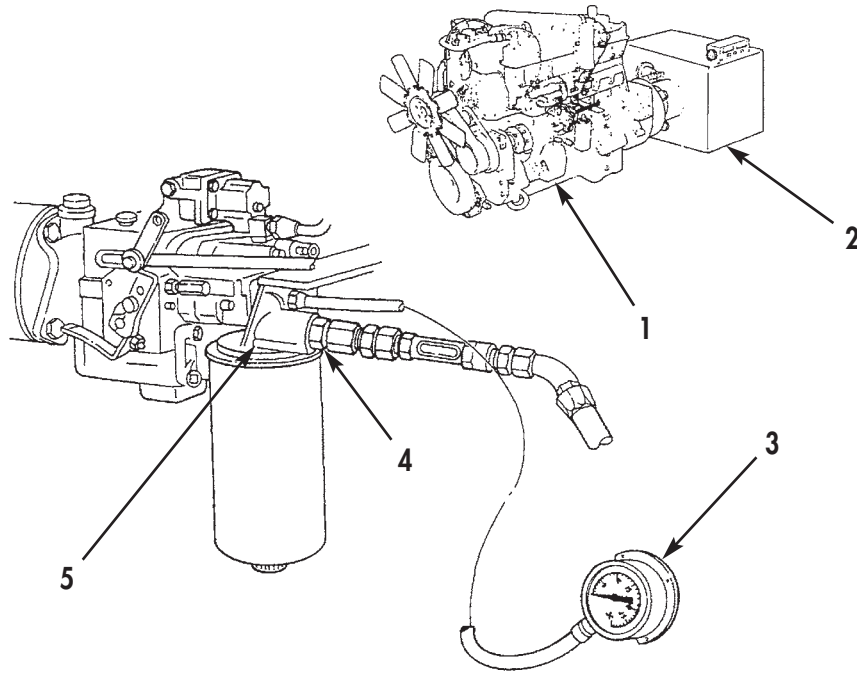


Figure 4. Checking Fuel Filter Restriction.

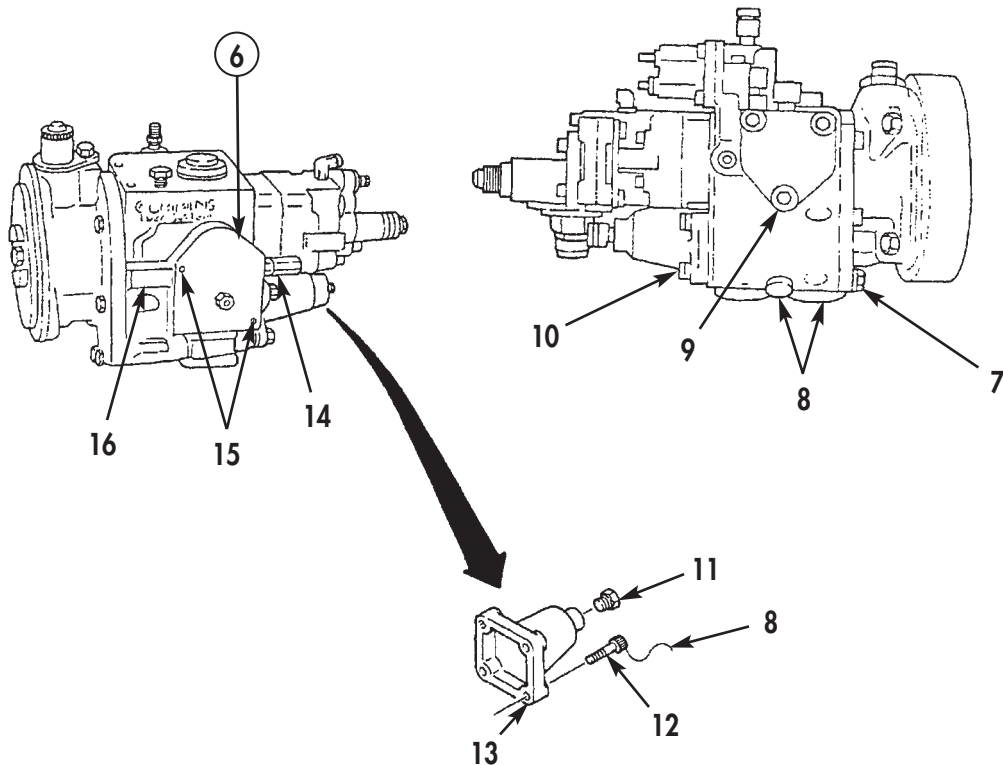


Figure 5. Fuel Pump Seal Installation.

**DIRECT SUPPORT AND GENERAL SUPPORT
MAINTENANCE MANUAL
INCLUDING REPAIR PARTS AND SPECIAL TOOLS LIST (RPSTL)**

FOR

M915, M915A1, M915A4, M916, M920 VEHICLES

NSN 2815-01-082-8125	P/N NTC400-3652-02	CUMMINS NTC-400 BIG CAM I DIESEL ENGINE W/CONTAINER
NSN 2815-01-142-2745	P/N 11669835	CUMMINS NTC-400 BIG CAM III DIESEL ENGINE W/CONTAINER

ENGINE ACCESSORIES INSTALLATION

**AIR AFTERCOOLER, FUEL PUMP AND FUEL LINES,
VIBRATION DAMPER AND CRANKSHAFT PULLEY**

INITIAL SETUP:

Tools and Special Tools

General mechanic's tool kit: automotive
(Item 1, WP 0061 00)
Maintenance and repair shop equipment:
automotive (Item 2, WP 0061 00)
Automotive maintenance and repair
supplemental set no. 2 (Item 3, WP 0061 00)
Air compressor wrench (Item 18, WP 0061 00)

Equipment Condition

Engine mounted on maintenance stand
(WP 0009 00)

References

TM 9-2320-273-20
TM 9-2320-283-20

Material/Parts

Lubricating oil (Item 19, WP 0060 00)
High pressure lubricant (Item 15, WP 0060 00)
Three gaskets (Item 1, Table 28, WP 0062 00)
Three lockwashers
(Item 2, Table 28, WP 0062 00)
Gasket (Item 3, Table 28, WP 0062 00)
Lockwasher (Item 4, Table 28, WP 0062 00)
Three lockwashers
(Item 5, Table 28, WP 0062 00)
Two lockwasher
(Item 6, Table 28, WP 0062 00)
Lockwasher (Item 7, Table 28, WP 0062 00)

ENGINE ACCESSORIES INSTALLATION (Contd)

AIR AFTERCOOLER

1. Apply a small amount of high pressure lubricant to three new gaskets (9) on cylinder heads (1).

NOTE

Perform steps 2 and 3 for Big Cam III only. Tighten screws from the center outward.

2. Install air aftercooler (2) on cylinder heads (1) with six washers (6) and screws (7). Tighten screws (7) 20–25 lb-ft (27–34 N•m).
3. Install screw (8), two screws (5), three new lockwashers (4) and washers (3) on bottom of each cylinder head (1). Thread in screws (8) and (5) three to five times. Tighten screws (8) and (5) 20–25 lb-ft (27–34 N•m).

NOTE

Two middle holes in air aftercooler are used for mounting ether starting kit. Refer to TM 9-2320-273-20 or TM 9-2320-283-20 to install ether starting kit.

Tighten but do not torque screws after installation.

Perform steps 4 and 5 for Big Cam I.

4. Install air aftercooler (2) on cylinder heads (1) with six washers (6) and bolts (7).
5. Install three washers (3), new lockwashers (4) and bolts (5) on three outside holes of air aftercooler (2). Thread in bolts (5) three to five times.

ENGINE ACCESSORIES INSTALLATION (Contd)

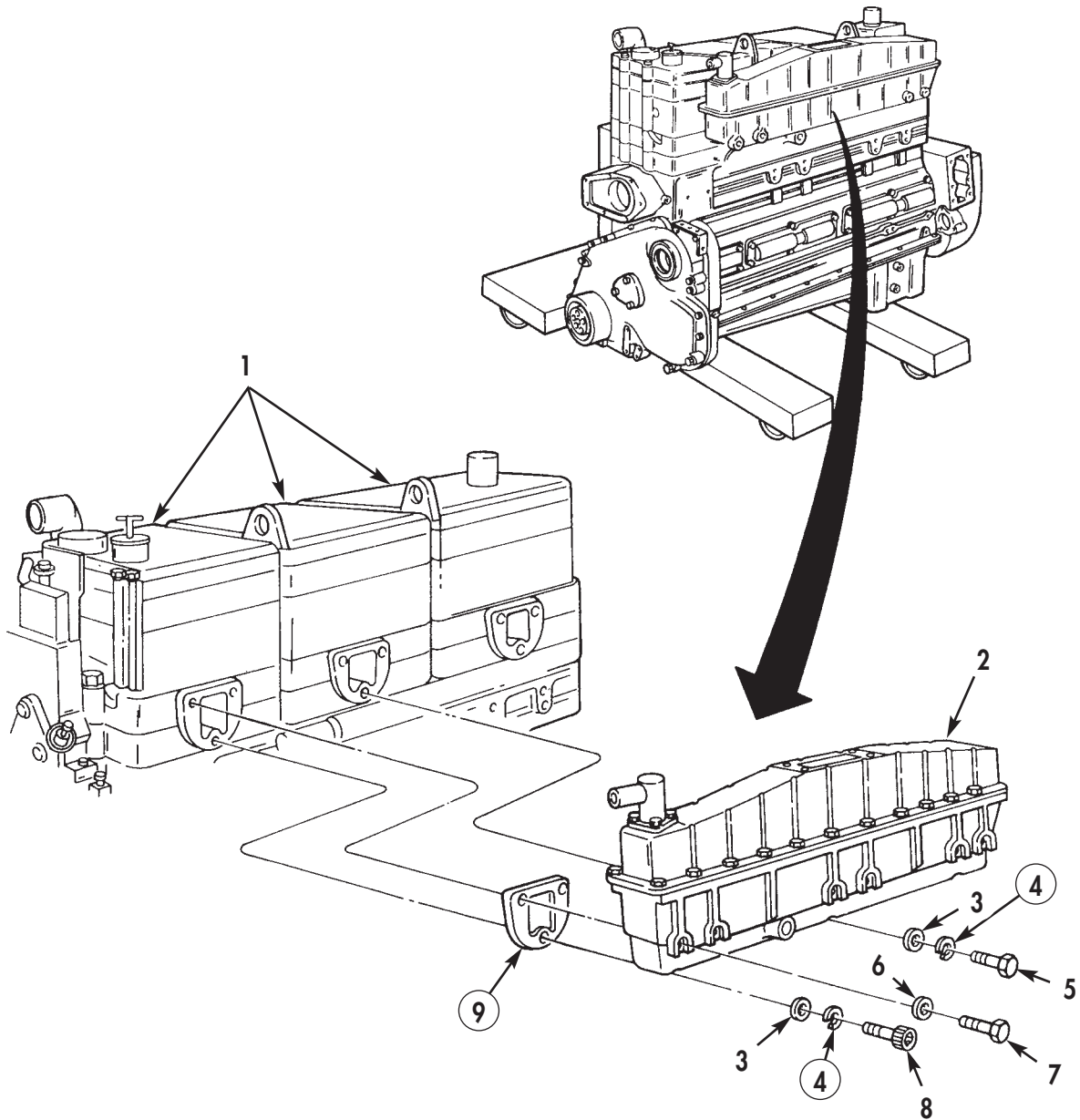


Figure 1. Air Aftercooler Installation.

ENGINE ACCESSORIES INSTALLATION (Contd)

FUEL PUMP AND FUEL LINES

1. Install new gasket (2) and fuel pump (12) with compressor spider coupling (3) on air compressor (1).

NOTE

Perform steps 2 and 3 for Big Cam III.

2. Position support bracket (9) on fuel pump (12) and air compressor (1) with three washers (10) and bolts (11).
3. Using air compressor wrench, install washer (14) and bolt (13) on fuel pump (12) and into air compressor (1). Tighten bolt (13) finger-tight only.

NOTE

Perform step 4 only for Big Cam I.

4. Using air compressor wrench, install support bracket (9) on fuel pump (12) and into air compressor (1) with four washers (4) and bolt (5).
5. Install new lockwasher (7) and bolt (6) on support bracket (9) and cylinder head (8).

ENGINE ACCESSORIES INSTALLATION (Contd)

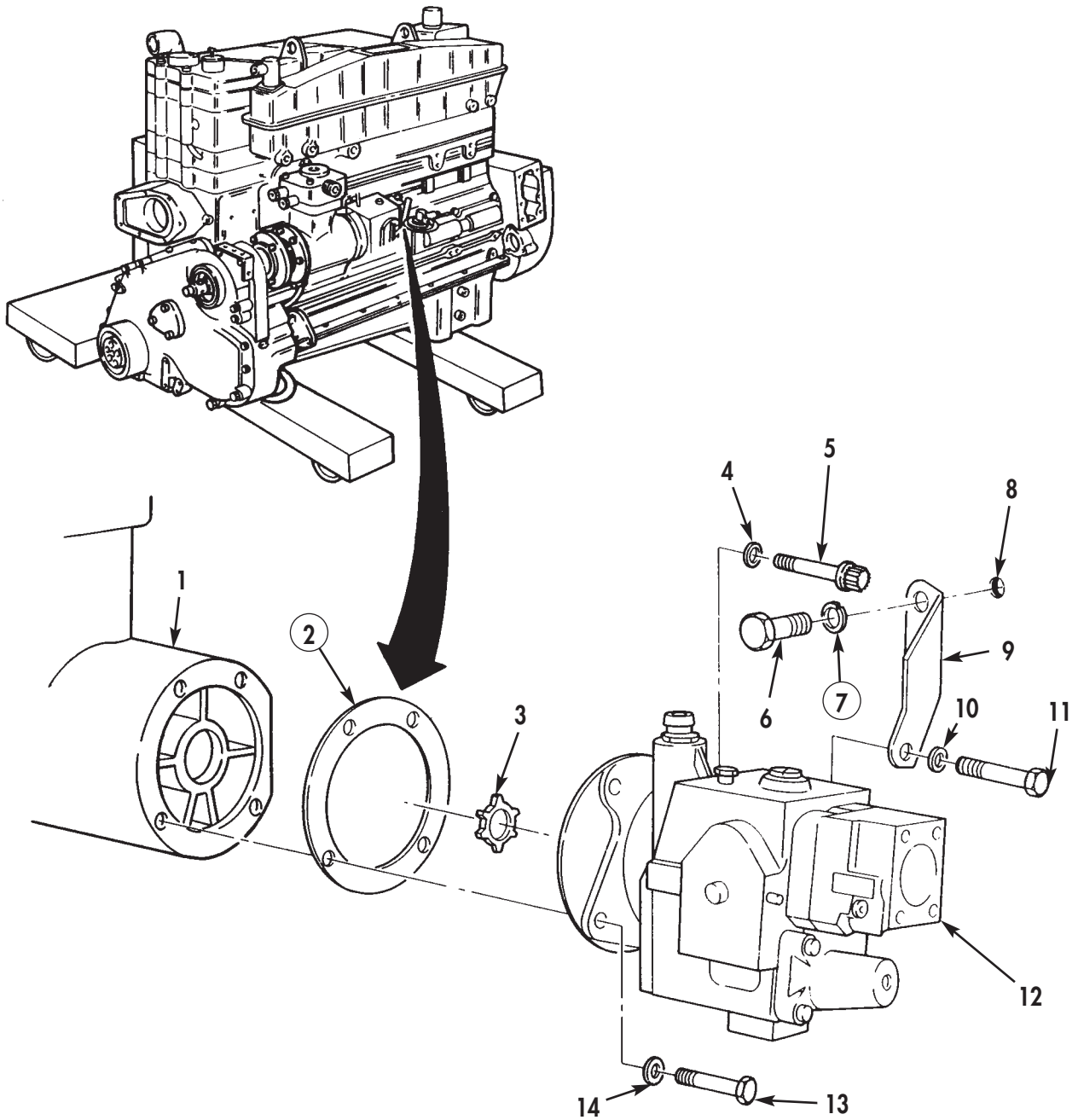


Figure 2. Fuel Pump Installation.

ENGINE ACCESSORIES INSTALLATION (Contd)

FUEL PUMP AND FUEL LINES (Contd)

6. Install fuel pump adapter (14) on fuel pump (29).
7. Install two cylinder head adapters (8), fuel supply line (9), and fuel return line (10) on cylinder head (7).
8. Install fuel pump adapter (16) and fuel supply line (9) on fuel pump (29).
9. Install fuel pump adapter (28) and fuel return lines (10) and (15) on fuel pump (29).
10. Install fuel supply line (9) and fuel return line (10) on air aftercooler (6) with two washers (11), new lockwashers (12), and screws (13).
11. Install valve (27) and air supply line (26) on fuel pump (29).
12. Install adapter (17) on air aftercooler (6).
13. Install bracket (25) and air supply line (26) with screw (18), washer (24), new lockwasher (23), and nut (22) on air aftercooler (6).

NOTE

Perform steps 14–16 for Big Cam I equipped with air signal attenuator (ASA) air tank.

14. Install ASA air tank (1) with washer (19), new lockwasher (20), and screw (21) on air aftercooler (6).
15. Install ASA hose fittings (2) on ASA air tank (1).
16. Install air aftercooler elbow (5) on air aftercooler (6).
17. Install two air supply hoses (4) and four hose clamps (3) on ASA air tank (1).

ENGINE ACCESSORIES INSTALLATION (Contd)

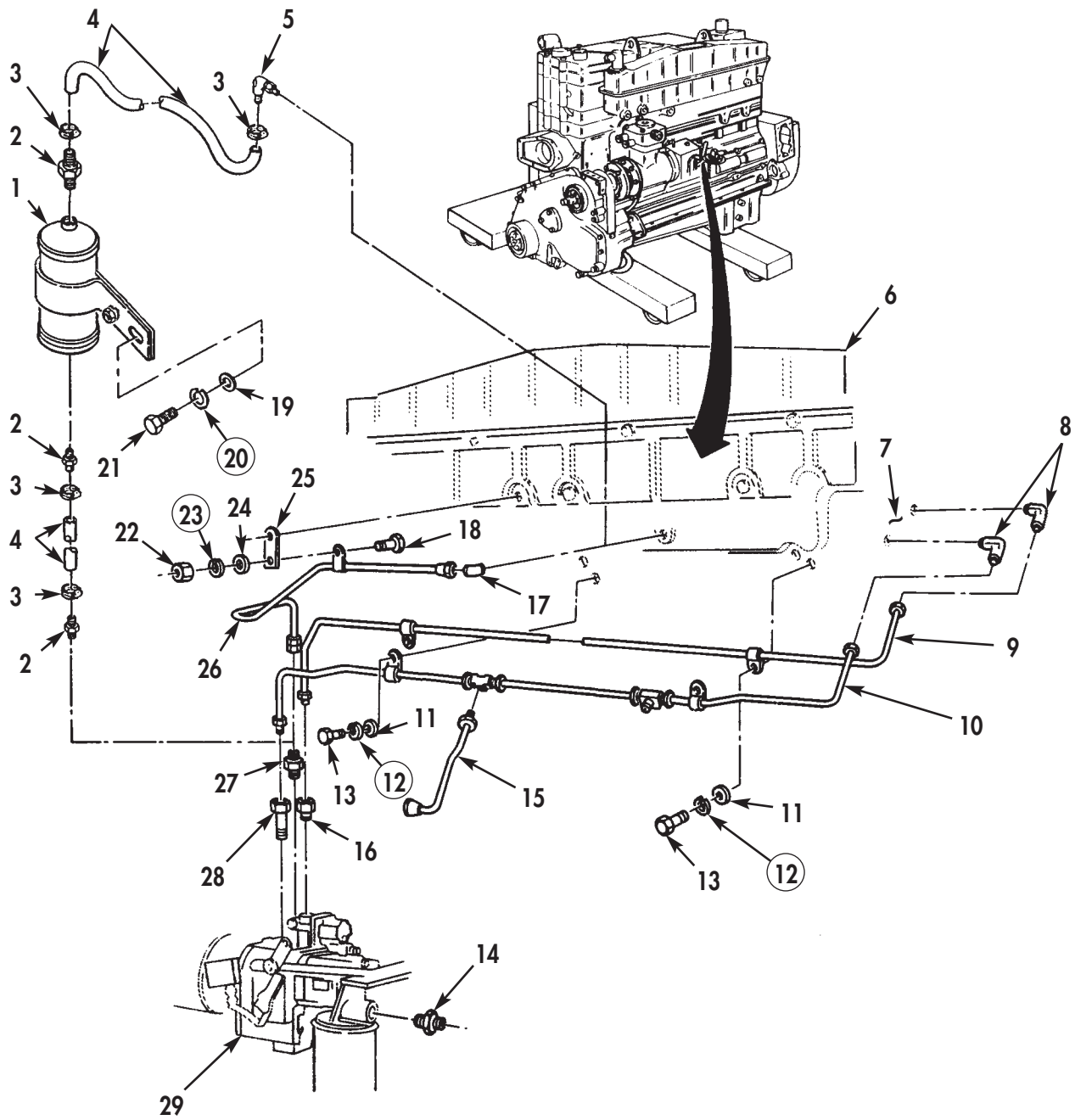


Figure 3. Fuel Lines Installation.

ENGINE ACCESSORIES INSTALLATION (Contd)

VIBRATION DAMPER AND CRANKSHAFT PULLEY

CAUTION

To avoid engine damage, ensure mounting surfaces of vibration damper and crankshaft pulley are clean and dry. Do not get any lubricating oil on these surfaces.

1. Install two vibration damper guide pins (5) on two opposite holes in face of crankshaft (6).
2. Install crankshaft pulley (4) and vibration damper (3) on two guide pins (5) and push into crankshaft (6) until seated.
3. Apply a coat of clean lubricating oil to threads of six screws (1) and washers (2).
4. Install four screws (1) and washers (2) on vibration damper (3), crankshaft pulley (4), and crankshaft (6).
5. Install remaining two screws (1) and washers (2) on vibration damper (3), crankshaft pulley (4), and crankshaft (6). Tighten screws 190 lb-ft (258 N•m).

NOTE

Total indicator reading must not exceed 0.004 in. (0.102 mm) per 1.0 in. (25.4 mm) of vibration damper diameter. Remove and discard vibration damper if not within limits.

6. Using dial indicator gauge, measure movement on vibration damper (3) circumference by rotating crankshaft (6).

NOTE

Crankshaft must be kept at front or rear limit of thrust clearance while measuring movement of vibration damper face. Total indicator reading must not exceed 0.007 in. (0.178 mm) per 1.0 in. (25.4 mm) of the vibration damper radius. Remove and discard vibration damper if not within limits.

7. Using dial indicator gauge, measure movement of vibration damper (3) face by rotating crankshaft (6).

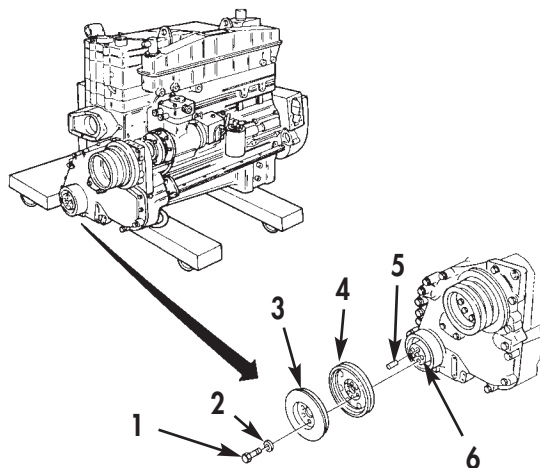


Figure 4. Vibration Damper and Crankshaft Pulley Installation.

**DIRECT SUPPORT AND GENERAL SUPPORT
MAINTENANCE MANUAL
INCLUDING REPAIR PARTS AND SPECIAL TOOLS LIST (RPSTL)**

FOR

M915, M915A1, M915A4, M916, M920 VEHICLES

NSN 2815-01-082-8125	P/N NTC400-3652-02	CUMMINS NTC-400 BIG CAM I DIESEL ENGINE W/CONTAINER
NSN 2815-01-142-2745	P/N 11669835	CUMMINS NTC-400 BIG CAM III DIESEL ENGINE W/CONTAINER

REMOVING ENGINE FROM MAINTENANCE STAND

INITIAL SETUP:

Tools and Special Tools

General mechanic's tool kit: automotive
(Item 1, WP 0061 00)
Maintenance and repair shop equipment:
automotive (Item 2, WP 0061 00)
Automotive maintenance and repair
supplemental set no. 2 (Item 3, WP 0061 00)
Maintenance stand
Chains

Material/Parts

Gasket (Item 1, Table 31, WP 0062 00)
Two water transfer hoses
(Item 2, Table 31, WP 0062 00)
Two gaskets (Item 3, Table 31, WP 0062 00)
Six O-rings (Item 4, Table 31, WP 0062 00)
Gasket (Item 5, Table 31, WP 0062 00)
Five lockwashers
(Item 6, Table 31, WP 0062 00)
Lockwasher (Item 7, Table 29, WP 0062 00)
Six lockwashers
(Item 8, Table 31, WP 0062 00 00)
Three gaskets (Item 9, Table 31, WP 0062 00)
Four lockplates
(Item 10, Table 31, WP 0062 00)
Four lockplates
(Item 11, Table 31, WP 0062 00)
Gasket (Item 12, Table 31, WP 0062 00)
Hose (Item 13, Table 31, WP 0062 00)
Gasket (Item 14, Table 31, WP 0062 00)
Gasket (Item 15, Table 31, WP 0062 00)

Material/Parts (Contd)

Lockwasher (Item 16, Table 31, WP 0062 00)
Lockwasher (Item 17, Table 31, WP 0062 00)

Equipment Condition

Engine mounted on maintenance stand
(WP 0009 00).

References

TM 9-2320-273-20
TM 9-2320-283-20

REMOVING ENGINE FROM MAINTENANCE STAND (Contd)

WARNING

Use extreme caution during disassembly or assembly; engine components are heavy. Failure to comply may result in damage to equipment or injury to personnel.

1. Install lifting device on engine lifting brackets.
2. Raise engine (1) just enough to take weight off maintenance stand.

WARNING

All personnel must stand clear during lifting operations. A snapped chain or swinging or shifting load may result in injury to personnel.

3. Remove four mounting screws (2) securing engine (1) to maintenance stand.

CAUTION

Ensure engine is supported by cylinder block, flywheel housing, or front support. Do not support engine on oil pan. Failure to comply may result in damage to engine.

4. Raise engine (1) from maintenance stand and support engine (1) on suitable blocks.

REMOVING ENGINE FROM MAINTENANCE STAND (Contd)

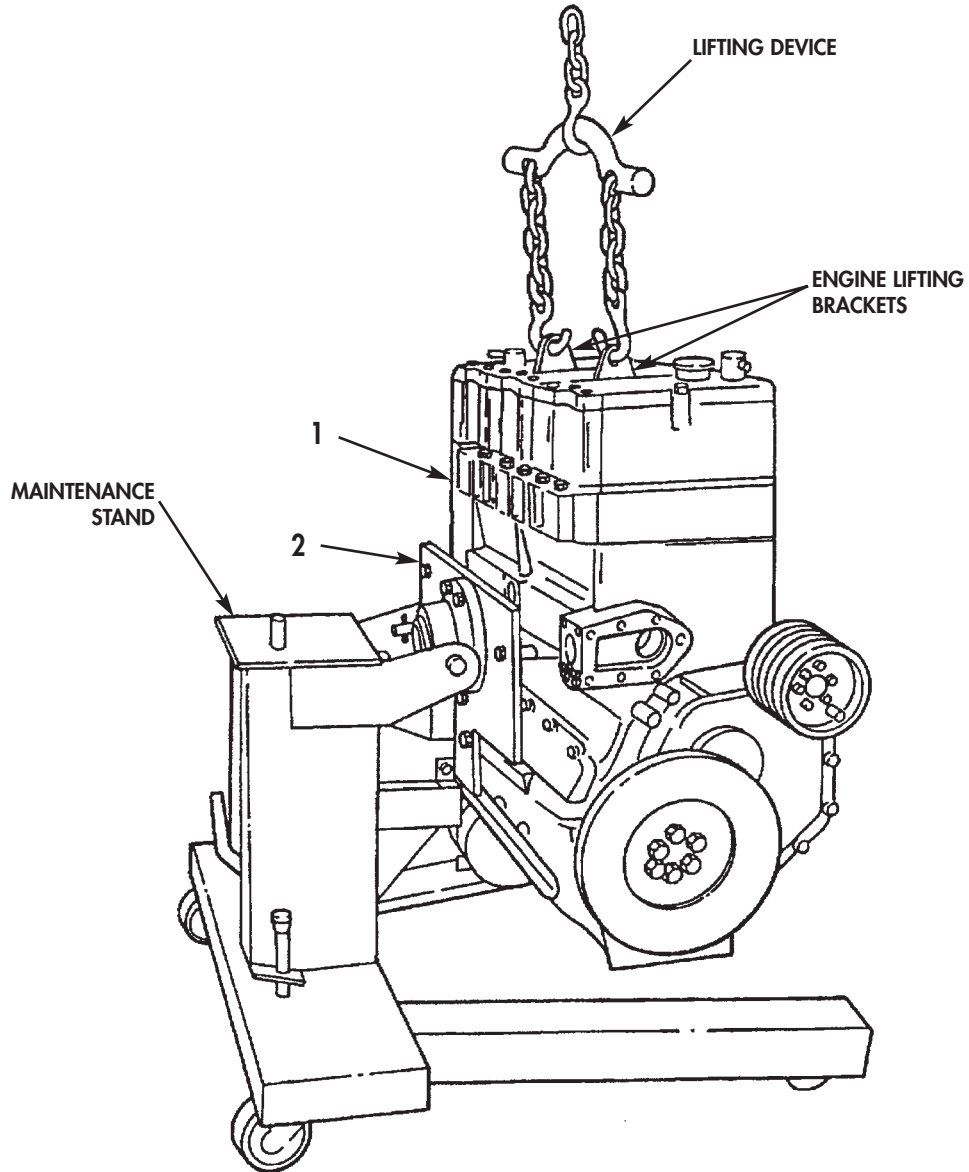


Figure 1. Removing Engine from Maintenance Stand.

REMOVING ENGINE FROM MAINTENANCE STAND (Contd)**NOTE**

Perform steps 5 and 6 on Big Cam I only.

5. Install new gasket (4) and water transfer flange (3) on cylinder block (1) with six screws (2). Tighten screws (2).
6. Install water transfer tube (6) and two new water transfer hoses (7) on water transfer flange (3) with four clamps (5).

NOTE

Perform steps 7 through 9 on Big Cam III only.

7. Install water head covers (9) and two new gaskets (8) on cylinder block (1) with twelve screws (10). Tighten screws (10).
8. Apply lubricating oil to six new O-rings (11) and position O-rings (11) on piston cooling nozzles (12).
9. Install six piston cooling nozzles (12) on cylinder block (1) with six screws (13). Tighten screws (13) 140 lb-in (16 N•m).
10. Install the following components on engine (1). Refer to TM 9-2320-273-20 or TM 9-2320-283-20.
 - a. Power steering pump and reservoir
 - b. Water pump and drivebelts
 - c. Fan brace, bracket, and spacers
 - d. Fan, fan clutch, and fan clutch drivebelts
 - e. Engine wiring harness
 - f. Ether quick-start cylinder, valve, safety switch, and thermostat
 - g. Modulator bracket and accelerator return spring
 - h. Air compressor governor and air lines
 - i. Air compressor intake tube
 - j. Air compressor discharge hose
 - k. Water bypass tube
 - l. Water pump-to-radiator connection
 - m. Water pump bypass hose

REMOVING ENGINE FROM MAINTENANCE STAND (Contd)

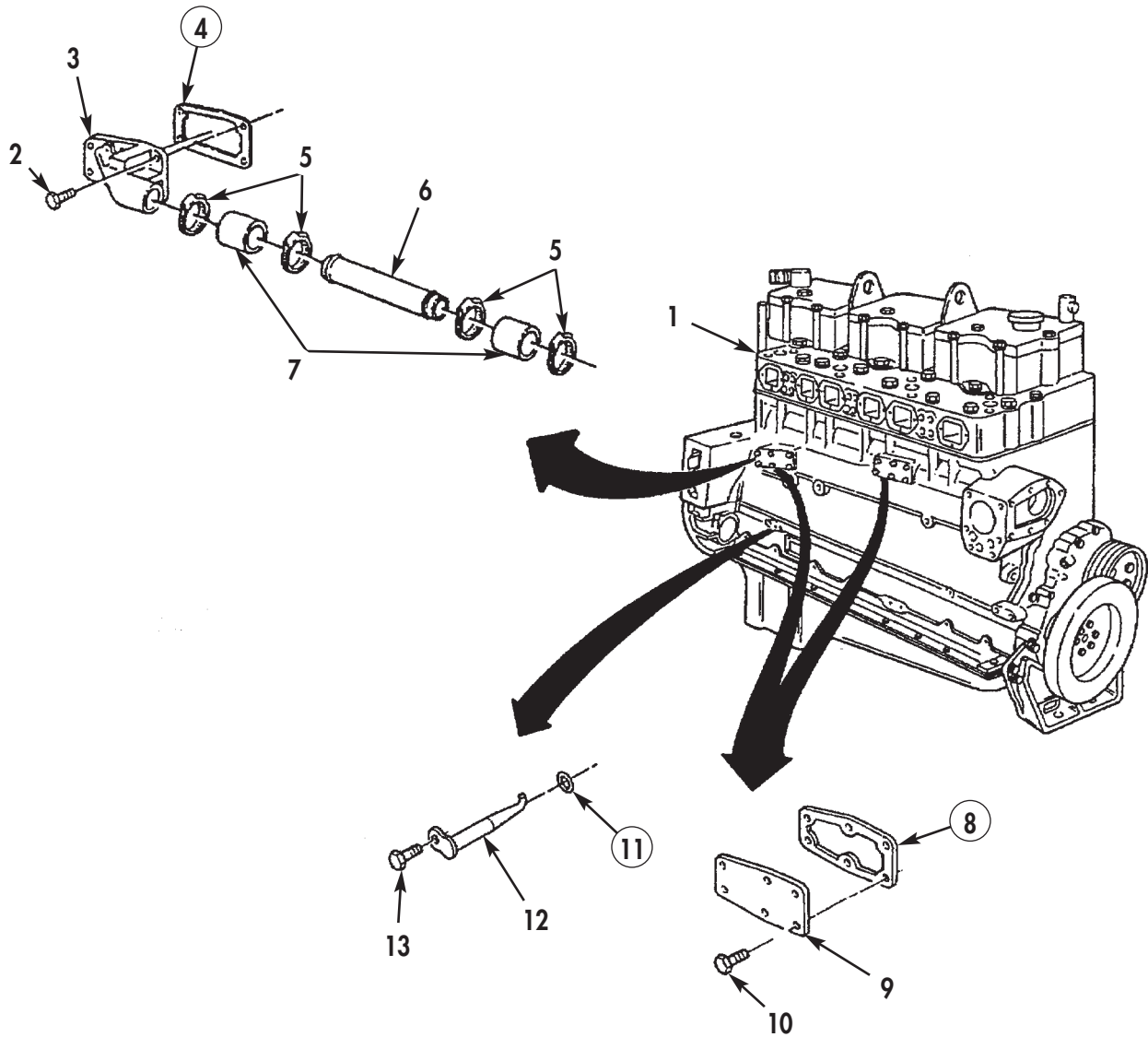


Figure 2. Piston Cooling Nozzles Installation.

REMOVING ENGINE FROM MAINTENANCE STAND (Contd)**NOTE**

Perform steps 11 through 13 on Big Cam I only.

11. Install oil cooler (11) and new gasket (8) on cylinder block (1) with five screws (6) and (10), and five new lockwashers (7) and (9). Tighten screws (6) and (10) 30–35 lb-ft (41–48 N•m).
12. Install oil transfer hose (2) on oil cooler (11) with clamp (3). Tighten clamp (3) at water transfer hose (2).
13. Install oil cooler support bracket (5) to cylinder block (1) with screw (12) and new lockwasher (4). Tighten screw (12) 30–35 lb-ft (41–48 N•m).

NOTE

Perform steps 14 and 15 on Big Cam III only.

14. Install oil cooler (19) and new gasket (13) on cylinder block (1) with six screws (15) and (16), washers (18), and new lockwashers (14) and (17). Tighten screws (15) and (16) 30–35 lb-ft (41–48 N•m).
15. Install the following components on cylinder block (1). Refer to TM 9-2320-273-20 or TM 9-2320-283-20.
 - a. Engine oil filter elements
 - b. Lower water transfer tube
 - c. Alcohol evaporator
 - d. Engine retarder microswitch
 - e. Water manifolds
 - f. Thermostat and thermostat housing
 - g. Engine temperature sending units and fuel line fittings.
 - h. Fan clutch air valve and air lines
 - i. Water transfer tube and bracket
 - j. Air compressor cooling tube

REMOVING ENGINE FROM MAINTENANCE STAND (Contd)

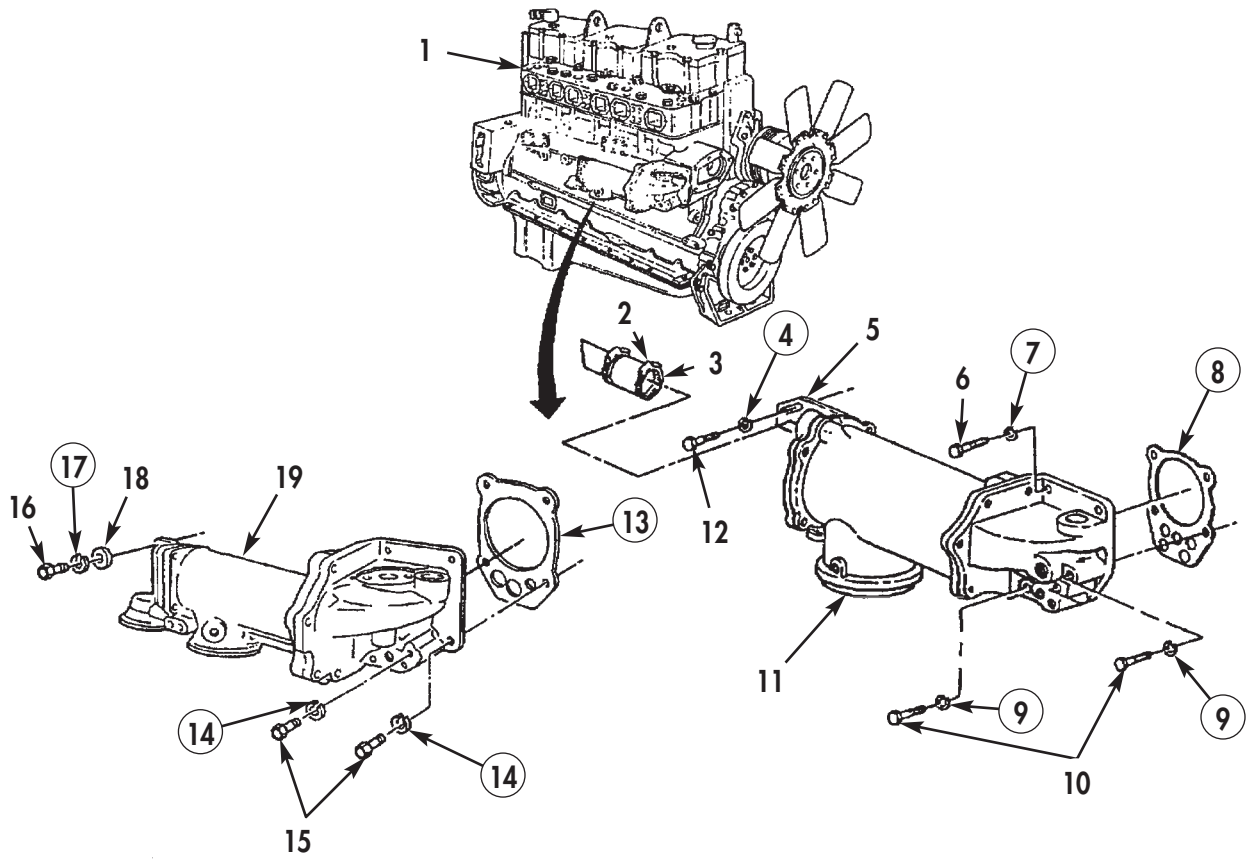


Figure 3. Oil Cooler Installation.

REMOVING ENGINE FROM MAINTENANCE STAND (Contd)

16. Install three new gaskets (2) on cylinder block (1) with word OUT facing exhaust manifold (3) or (7).

NOTE

Perform steps 17 through 19 for Big Cam I only.

17. Apply antiseize compound to threads of screws (10).
18. Install exhaust manifold (3), two clamps (12), four new lockplates (11), and dowels (13) on cylinder block (1) with four screws (10). Do not tighten screws (10).
19. Install four new lockplates (4) on exhaust manifold (3) with four screws (6) and new lockwashers (5). Tighten screws (6) and (10) alternately and evenly 15–20 lb-ft (20–27 N•m) and then 40–45 lb-ft (54–61 N•m).

NOTE

Perform step 20 on Big Cam III only.

20. Apply antiseize compound to threads of screws (9).
21. Install exhaust manifold (7) and spacer inserts (8) on cylinder block (1) with twelve screws (9). Tighten screws (9) alternately and evenly 15–20 lb-ft (20–27 N•m) and then 40–45 lb-ft (54–61 N•m).
22. Install the following components on cylinder block (1). Refer to TM 9-2320-273-20 or TM 9-2320-283-20.
- a. Water filter and bracket
 - b. Water shutoff valves and hoses

REMOVING ENGINE FROM MAINTENANCE STAND (Contd)

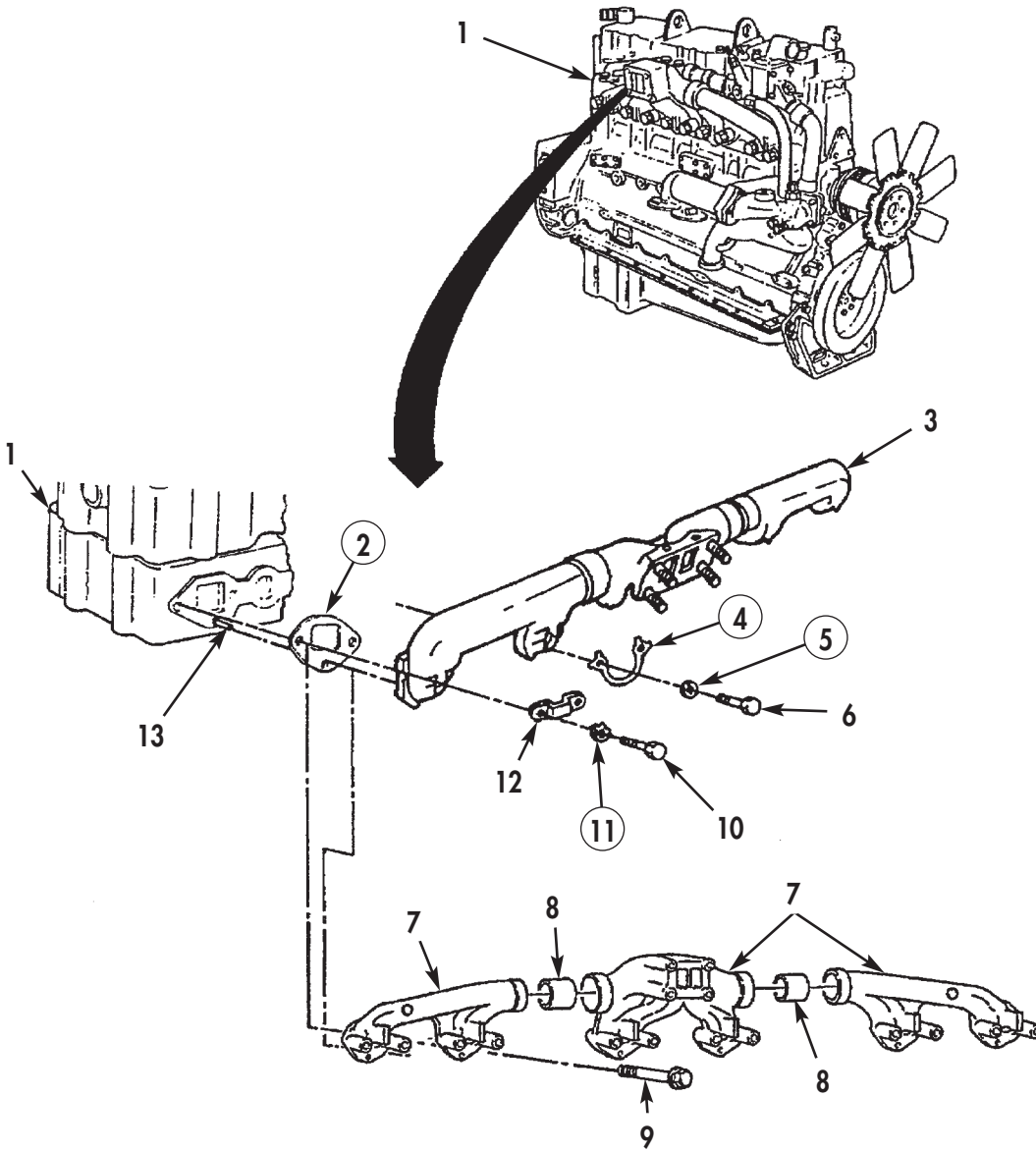


Figure 4. Exhaust Manifold Installation.

REMOVING ENGINE FROM MAINTENANCE STAND (Contd)

- 23. Apply antiseize compound to threads of studs (2) and install new gasket (3) on exhaust manifold studs (2).
- 24. Install turbocharger (5) on exhaust manifold (1) with four nuts (4). Tighten nuts (4) 20–25 lb-ft (27–34 N•m).

NOTE

Perform step 25 for Big Cam I only.

- 25. Install oil return tube (9) and hose (12) on elbows (8) and (16) with two clamps (11) and (13). Tighten clamps (11) and (13) 35–45 lb-ft (48–61 N•m).

NOTE

Perform steps 26 and 27 on Big Cam III only.

- 26. Install oil return tube (10) and hose (12) on elbows (6) and (16) with two clamps (11) and (13). Tighten clamps (11) and (13) 35–45 lb-ft (48–61 N•m).
- 27. Install oil return tube (7) and two bushings (14) and (17) on filter head (15) and oil return tube (10). Tighten fittings on oil return tube (7) 50–60 lb-ft (68–81 N•m).
- 28. Install oil supply hose (19) on adapter (18) and elbow (22). Tighten fittings on oil supply hose (19) 50–60 lb-ft (68–81 N•m).
- 29. Install clamp (20) and screw (21) on turbocharger (5). Tighten screw (21) 14 lb-ft (19 N•m).
- 30. Install four bolts (25), washers (26), turbocharger air crossover (27), clamps (28) and (30), new hose (29), and new gasket (32) on aftercooler cover (31).
- 31. Install hose (23) and fitting (24) on turbocharger air crossover (27).
- 32. Tighten clamps (28) and (30) retaining turbocharger air crossover (27) and hose (29) to turbocharger (5).

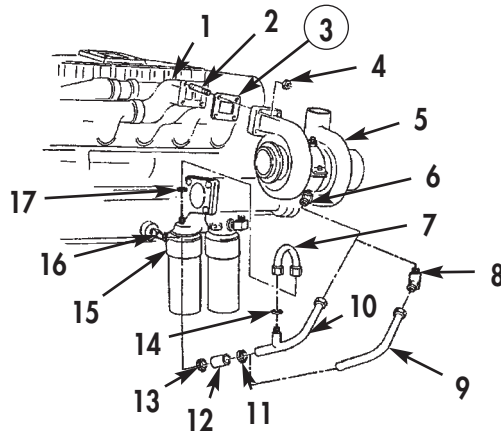


Figure 5. Turbocharger Installation

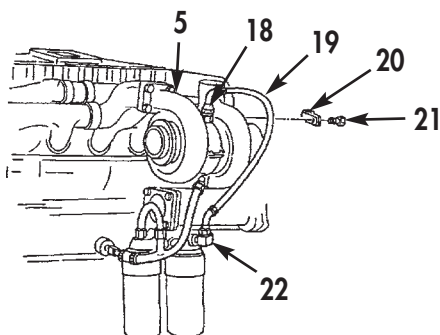


Figure 6. Turbocharger Oil Supply Hose Installation.

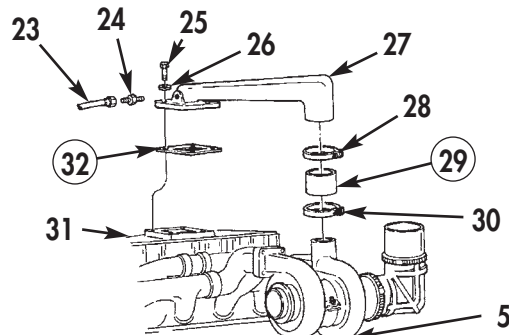


Figure 7. Turbocharger Air Crossover Installation.

REMOVING ENGINE FROM MAINTENANCE STAND (Contd)

33. Install new gasket (45), and oil level dipstick tube and cover (38) on cylinder block (46) with four washers (44) and captive washer screws (43). Tighten captive washer screws (43) 30–35 lb-ft (41–48 N•m).
34. Install tube brace (33) and clamp (42) on oil level dipstick tube and cover (38) with two washers (41), screw (36), new lockwasher (40), and nut (39). Tighten nut (39).
35. Install tube brace (33) on cylinder block (46) with screw (36), washer (34), and new lockwasher (35).

NOTE

Perform step 36 for Big Cam I only.

36. Install transmission control-body heating elements ON/OFF switch (47) on cylinder block (46).
37. Install oil pressure gauge sending unit (48) and low oil pressure warning light sending unit (49) on cylinder block (46).

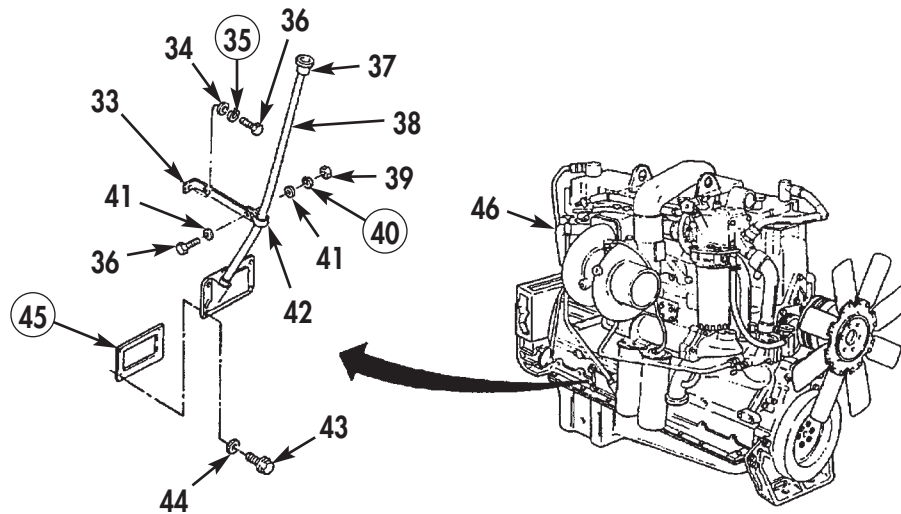


Figure 8. Oil Level Dipstick Tube Installation.

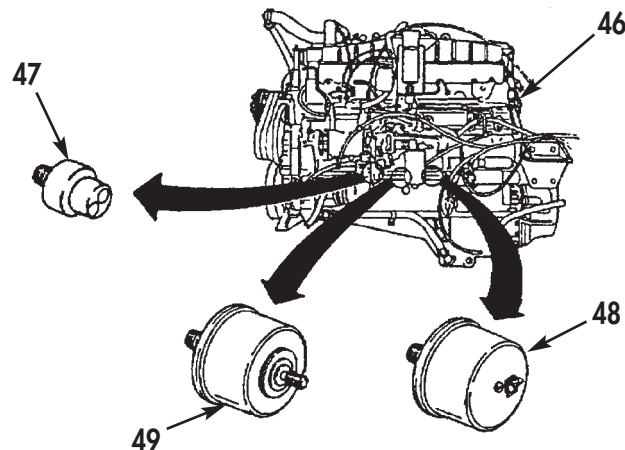


Figure 9. Oil Pressure Gauge Sensing Unit Installation.

**DIRECT SUPPORT AND GENERAL SUPPORT
MAINTENANCE MANUAL
INCLUDING REPAIR PARTS AND SPECIAL TOOLS LIST (RPSTL)
FOR
M915, M915A1, M915A4, M916, M920 VEHICLES**

NSN 2815-01-082-8125	P/N NTC400-3652-02	CUMMINS NTC-400 BIG CAM I DIESEL ENGINE W/CONTAINER
NSN 2815-01-142-2745	P/N 11669835	CUMMINS NTC-400 BIG CAM III DIESEL ENGINE W/CONTAINER

ENGINE TESTING

GENERAL INFORMATION, PRE-TEST INSPECTION,
INSTALLATION OF ENGINE ON DYNAMOMETER, CONDITIONS FOR TESTING, FINAL ACCEPTANCE TEST,
BREAK-IN RUNNING, ENGINE TEST, POWER CHECK, SMOKE LEVEL CHECK, FINAL CHECK

INITIAL SETUP:

Tools and Special Tools

General mechanic's tool kit: automotive
(Item 1, WP 0061 00)
Maintenance and repair shop equipment,
automotive (Item 2, WP 0061 00)
Automotive maintenance and repair
supplemental set no. 2 (Item 3, WP 0061 00)
Manometer (Item 57, WP 0061 00)
Blow-by check tool (Item 58, WP 0061 00)

Materials/Parts

Lubricating oil, engine (Item 20, WP 0060 00)

ENGINE TESTING (Contd)

GENERAL INFORMATION

The engine test is a combination of a run-in procedure and a performance check. The run-in procedure provides an operating period that allows engine parts to achieve a final finish and fit. The performance check confirms that the engine will operate at its specified speed and torque rating, that it is leak free, that it is free of abnormal noises, and that its various systems are operating within specified values.

In the event of conflicting instructions between this procedure and other references, this procedure will take precedence.

Dynamometer must have sufficient capacity to permit testing at 100 percent of engine's 400 hp @ 2100 rpm.

PRE-TEST INSPECTION

The engine will be inspected for completeness and obvious damage before testing/performance check (no missing accessories, drive belts installed properly, no missing screws or nuts, etc.).

INSTALLATION OF ENGINE ON DYNAMOMETER

1. Mount engine (4) on dynamometer test stand following manufacturer's instructions.
2. Cover, or plug, breather tube (2).

NOTE

Using blow-by measuring tool and water manometer, fill to 0 mark at middle of scale. Close all other engine openings that would allow blow-by pressure to escape.

3. Install blow-by measuring tool in place of oil filler cap (1).
4. Connect air compressor (3) to a 0.125–0.130 in. (3.175–3.302 mm) diameter orifice adapter located downstream from a 150 psi (1034 kPa) pressure relief valve.

CONDITIONS FOR TESTING

CAUTION

Failure to comply with the following could result in damage to equipment.

1. Do not run engine (4) with less than 35 psi (241 kPa) of oil pressure.
2. Engine oil pressure must not exceed 90 psi (689.5 kPa) at any time.
3. Engine oil temperature must not exceed 250° F (121° C) at any time.
4. Engine coolant temperature must not exceed 210° F (96.0° C) at any time.
5. Do not run engine (4) under full power/load conditions when oil temperature or coolant temperature is below 190° F (88° C).
6. Do not shut down engine (4) following heavy power/load runs without a minimum of a 5-minute cool-down, no-load run.

ENGINE TESTING (Contd)

FINAL ACCEPTANCE TEST

1. Start engine (4) and operate at idle for 5 minutes. Check for low oil pressure, high coolant temperature, leaks, and unusual noises. No fuel leaks are allowed. Only Class I oil leaks are allowed as described below.

CLASS I— Seepage of fluid (as indicated by wetness or discoloration) not great enough to form drops.

CLASS II— Leakage of fluid great enough to form drops, but not enough to cause drops to drip from item being checked/inspected.

CLASS III—Leakage of fluid great enough to form drops that fall from the item being checked/inspected.

2. Stop engine (4) after 5 minutes of operation. Allow engine (4) to stand for 2 minutes while checking for leaks and unusual conditions.

CAUTION

Except in emergency, do not stop engine immediately after completion of power/torque runs. Sudden stopping without cool-down may cause damage to engine components. Cool-down period is 5 minutes (minimum) after any power/torque run.

3. Start engine (4), test, and record results.
4. Prior to removal of engine (4) from dynamometer test stand, whether accepted or rejected, an oil sample must be taken as specified in AR 750-22.
5. After completion of test, disconnect engine (4) and remove from dynamometer test stand.

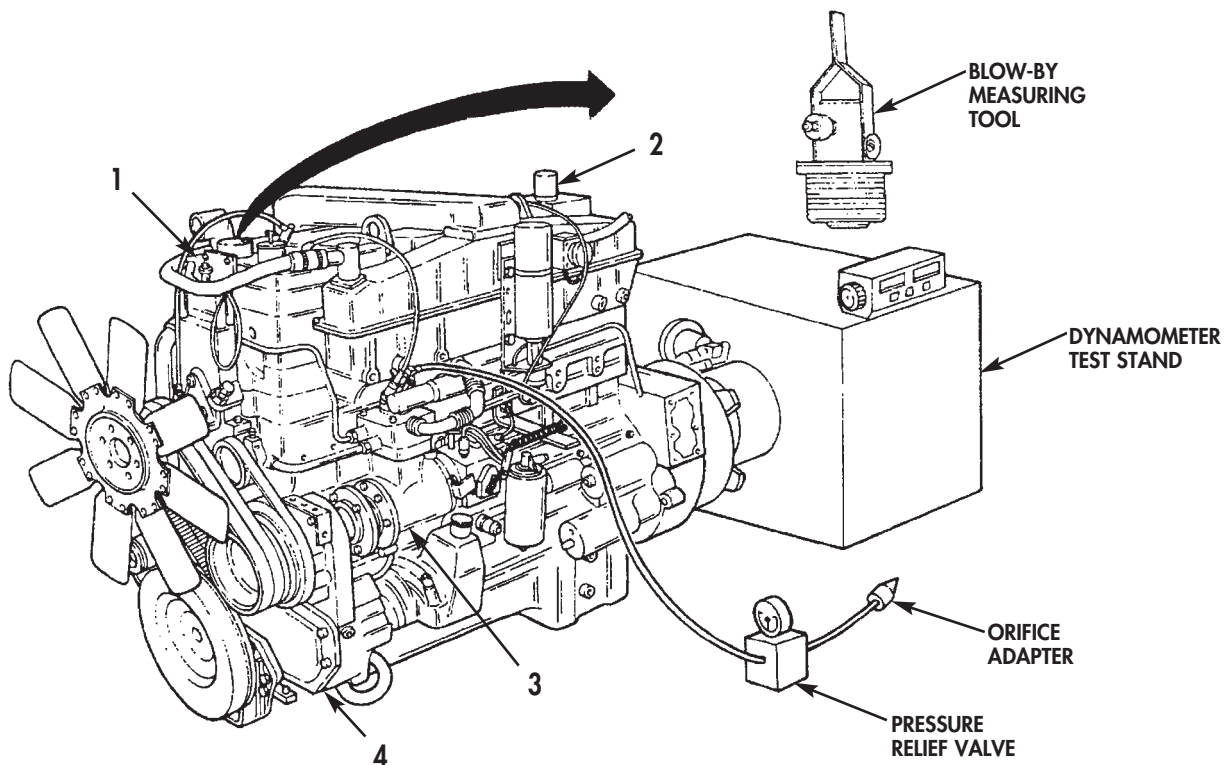


Figure 1. Engine Installation on Dynamometer Test Stand.

ENGINE TESTING (Contd)

BREAK-IN RUNNING

CAUTION

Once normal operating temperature is reached, oil pressure must remain at or near a constant figure for a constant engine speed and load. Acceptable lubricating oil pressures are 5–20 psi (34–138 kPa) at idle speed and 35–45 psi (241–310 kPa) for Big Cam III and 40–75 psi (276–517 kPa) for Big Cam I at rated speed. Abnormally high pressures may indicate blocked lubricating oil lines. Abnormally low pressures indicate an insufficient supply of lubricating oil from the pump or increased engine clearance which may be due to bearing failure. Damage to engine may occur if oil pressure fails outside of acceptable range at indicated speeds.

Lubricating oil temperature must not rise sharply above 225° F (107° C). Shut down engine and correct as necessary. Damage to engine may occur if oil temperature rises above acceptable limit.

Check temperature of coolant. Temperature should not exceed 200° F (93° C) or drop below 160° F (71° C) during engine tests. Do not turn engine off immediately after a load run. Heat stored in engine will boil coolant in the water jackets if air and coolant circulation are immediately stopped while engine is hot. Allow engine to idle a minimum of 3 minutes before shutting down.

Do not idle engine for prolonged periods of time before completing break-in running. Failure to comply may result in damage to equipment.

1. Start engine (2) and idle at 1200 rpm no-load for 5–10 minutes. Operate air compressor (1) in pumping mode.
2. Check oil pressure, oil temperature, water temperature and inspect for leaks.

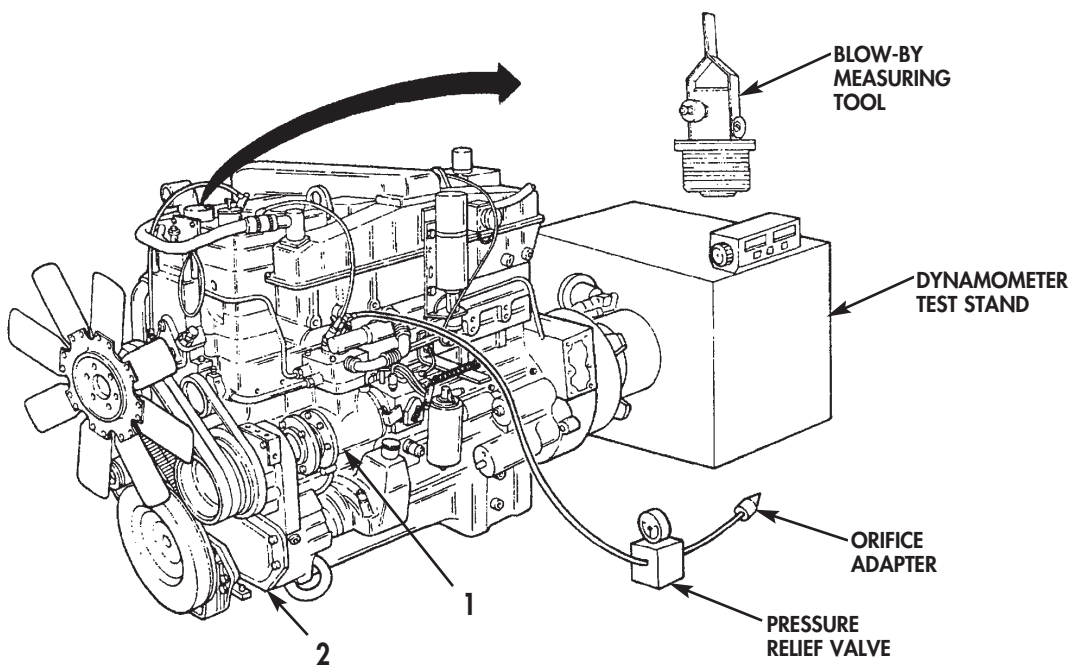


Figure 2. Break-In Running and Engine Test.

ENGINE TESTING (Contd)

ENGINE TEST

NOTE

At each phase, record crankcase pressure blow-by, engine speed, and load at 1 minute intervals. Watch for increases or wide shifts in blow-by pressure. If a sudden increase in blow-by pressure occurs or if blow-by exceeds 12 in. H₂O, return to the previous phase test or repeat phase 1 test and operate engine an additional 15 minutes. If blow-by does not reach an acceptable level after repeating test for 15 minutes, discontinue test and determine cause. If blow-by is within an acceptable level, proceed to next phase test.

After each test, check for fuel, air, water, oil, or exhaust leaks and correct as necessary.

Lubricating oil level is checked only when engine is shut down or incorrect readings on dipstick will result.

Refer to Phase 1 Test in Dynamometer Test Chart for steps 1 through 7.

1. Apply load to engine (2) at +/- 10 percent horsepower, +/- 5 percent speed.
2. Check crankcase pressure with blow-by measuring tool.
3. Operate engine (2) until normal oil operating temperature is attained.
4. Stop engine (2) and check lubricating oil level.
5. Add lubricating oil to bring level up to H (high) on dipstick.
6. Allow oil temperature to stabilize.
7. Operate air compressor (1) in pumping mode.

Dynamometer Test Chart

HP @ RPM	FUEL RATE LB/HR	AIR MANIFOLD PRESSURE IN/HG	CRANKCASE PRESSURE W/TURBO T46B	PHASE 1 160° F HP @ RPM	PHASE 2 2 MIN. HP @ RPM	PHASE 3 5 MIN. HP @ RPM	PHASE 4 4 MIN. HP @ RPM	POWER CHECK 4 MIN. HP @ RPM
400 @ 2100	139-145	39/47	12 in. H ₂ O	100 @ 1200	160 @ 1200	260 @ 1600	Full Load @ 1200	384 @ 2100

ENGINE TESTING (Contd)

ENGINE TEST (Contd)

NOTE

Refer to Phase 2 Test in Dynamometer Test Chart for steps 8 through 12.

8. Apply load to engine (2) at +/- 10 percent horsepower, +/- 5 percent speed.
9. Check pressure with blow-by measuring tool.
10. Set idle speed to 600 rpm and set full load governed speed to 2100 rpm.
11. Adjust load and rpm until specified readings are obtained.
12. Operate air compressor (1) in pumping mode.

NOTE

Refer to Phase 3 Test in Dynamometer Test Chart for steps 13 through 15.

13. Apply load to engine (2) at +/- 10 percent horsepower, +/- 5 percent speed.
14. Check crankcase pressure with blow-by measuring tool.
15. Operate air compressor (1) in pumping mode.

NOTE

After phase 4 test is completed, allow engine to run at low idle for a minimum of three minutes before shutting down.

Refer to Phase 4 Test in Dynamometer Test Chart for steps 16 through 19.

16. Apply load to engine (2) at +/- 10 percent horsepower, +/- 5 percent speed.
17. Check crankcase pressure with blow-by measuring tool.
18. Check for leaks and retighten all external screws to correct specifications.
19. Operate air compressor (1) in non-pumping mode.

POWER CHECK

CAUTION

Do not shut engine down immediately after power check is complete. Serious engine damage may result.

1. Run engine (2) at 2100 rpm for 4 minutes.
2. Check crankcase pressure with blow-by measuring tool. Repeat procedure until engine (2) develops 96–100% rated horsepower at standard fuel rate within permissible crankcase pressure limit. Operate air compressor (1) in non-pumping mode.

NOTE

At each phase, record crankcase pressure (blow-by) engine speed, and load at one-minute intervals. Watch for increases or wide shifts in blow-by pressure. If sudden increase happens, or if it is more than 12 in. H₂O, perform the preceding test over again and run engine 15 more minutes. When blow-by is OK, proceed to next test. If not OK, stop the test and find reason for too much blow-by. Check engine for fuel, oil, water, air, or exhaust leaks after each test and fix as needed.

After each test, check for fuel, air, water, oil, or exhaust leaks and correct as necessary.

3. Apply dynamometer test stand load as engine (2) rpm is increased until rated rpm and horsepower are reached and load is stabilized.

ENGINE TESTING (Contd)

POWER CHECK (Contd)

Dynamometer Test Chart

HP @ RPM	FUEL RATE LB/HR	AIR MANIFOLD PRESSURE IN/HG	CRANKCASE PRESSURE W/TURBO T46B	PHASE 1 160° F HP @ RPM	PHASE 2 2 MIN. HP @ RPM	PHASE 3 5 MIN. HP @ RPM	PHASE 4 4 MIN. HP @ RPM	POWER CHECK 4 MIN. HP @ RPM
400 @ 2100	139-145	39/47	12 in. H ₂ O	100 @ 1200	160 @ 1200	260 @ 1600	Full Load @ 1200	384 @ 2100

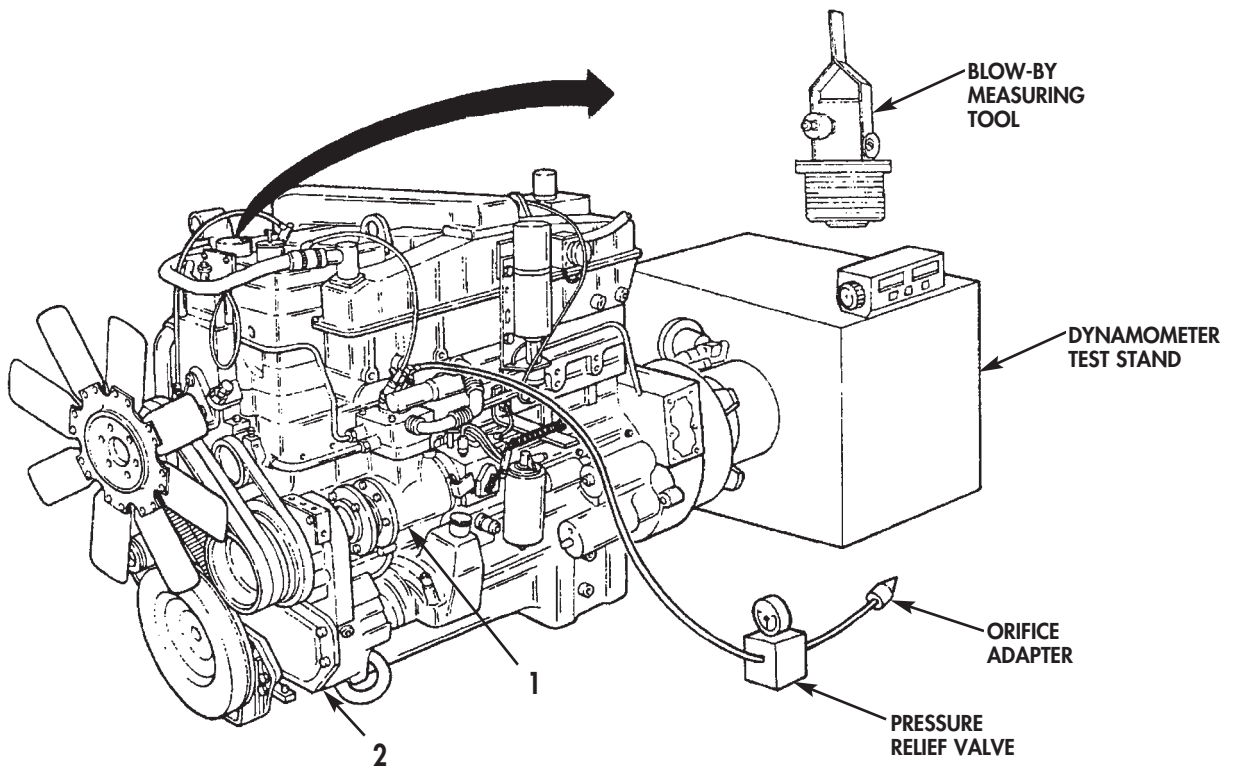


Figure 3. Engine Testing and Power Check.

ENGINE TESTING (Contd)

SMOKE LEVEL CHECK

NOTE

Zero and place opacity meter at exhaust side of turbocharger.

An accurate smoke reading can usually be obtained in 10 to 15 seconds.

1. Using 0–20 scale on opacity meter, record smoke reading. Specification is 12.84 percent (3.6 percent Bosch).
2. Increase dynamometer test stand load until rpm is reduced to 60 percent of rated rpm.
3. Using 0–20 scale on opacity meter, record smoke reading. Specification is 3.87 percent (1.0 percent Bosch). Remove meter after reading is taken.
4. Reduce dynamometer test stand load and engine (3) rpm.
5. Accelerate engine (3) to rated rpm, no-load and return to idle. Full acceleration should occur in 3–5 seconds.

NOTE

Zero and place opacity meter at exhaust side of turbocharger.

6. Using 0–100 scale on opacity meter, accelerate engine (3) to rated rpm, no-load and record highest reading. Specification is 22 percent (4.3 percent Bosch).
7. Return engine (3) to idle.

FINAL CHECK

NOTE

If there is no rapid change in excess of 2 in. of water and reading does not exceed 100 percent of representative pressure, blow-by is acceptable. Manometer readings not exceeding 0.3 in. (7.62 mm) surge are desirable.

At each phase, record crankcase pressure (blow-by), engine speed, and load at one minute intervals. Watch for increases or wide shifts in blow-by pressure. If sudden increase happens, or if it is more than 12 in. H₂O, perform the preceding test over again and run engine 15 more minutes. If not OK, stop the test and find reason for too much blow-by. Check engine for fuel, oil, water, air, or exhaust leaks after each test and fix as needed.

1. Using blow-by measuring tool, check pressure at end of testing procedure. If pressure is greater than specification listed in test chart, run engine (3) for additional 30 minutes at 96–100 percent rated load and rpm.
2. Remove orifice adapter from pressure relief valve.
3. Remove blow-by measuring tool from engine (3) and install oil filler cap (1) on engine (3).
4. Unplug breather tube (2).

ENGINE TESTING (Contd)

FINAL CHECK (Contd)

Dynamometer Test Chart

HP @ RPM	FUEL RATE LB/HR	AIR MANIFOLD PRESSURE IN/HG	CRANKCASE PRESSURE W/TURBO T46B	PHASE 1 160° F HP @ RPM	PHASE 2 2 MIN. HP @ RPM	PHASE 3 5 MIN. HP @ RPM	PHASE 4 4 MIN. HP @ RPM	POWER CHECK 4 MIN. HP @ RPM
400 @ 2100	139-145	39/47	12 in. H ₂ O	100 @ 1200	160 @ 1200	260 @ 1600	Full Load @ 1200	384 @ 2100

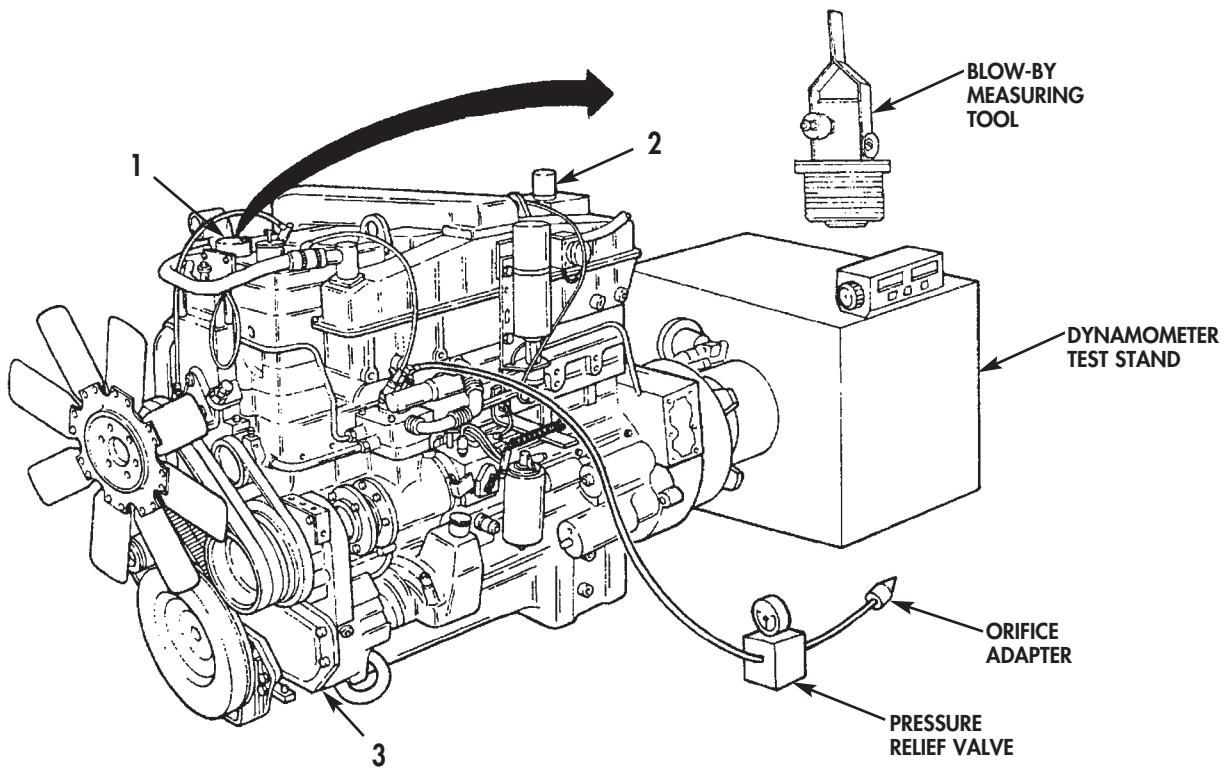


Figure 4. Final Check.

**DIRECT SUPPORT AND GENERAL SUPPORT
MAINTENANCE MANUAL
INCLUDING REPAIR PARTS AND SPECIAL TOOLS LIST (RPSTL)**

FOR

M915, M915A1, M915A4, M916, M920 VEHICLES

NSN 2815-01-082-8125	P/N NTC400-3652-02	CUMMINS NTC-400 BIG CAM I DIESEL ENGINE W/CONTAINER
NSN 2815-01-142-2745	P/N 11669835	CUMMINS NTC-400 BIG CAM III DIESEL ENGINE W/CONTAINER

BIG CAM III ENGINE INSTALLATION

INITIAL SETUP:

Tools and Special Tools

General mechanic's tool kit: automotive
(Item 1, WP 0061 00)
Maintenance and repair shop equipment:
automotive (Item 2, WP 0061 00)
Lifting sling (Item 42, WP 0061 00)
Lifting bracket (Item 43, WP 0061 00)
Tilt sling (Item 67, WP 0061 00)

Materials/Parts

Starter positive terminal lockwasher
(Item 1, Table 29, WP 0062 00)
Six air cleaner housing locknuts
(Item 2, Table 29, WP 0062 00)
Two hood hinge locknuts
(Item 3, Table 29, WP 0062 00)
Four air cleaner housing bracket locknuts
(Item 4, Table 29, WP 0062 00)
Four radiator support rod locknuts
(Item 5, Table 29, WP 0062 00)
Air cleaner element
(Item 6, Table 29, WP 0062 00)
Two radiator crossmember mount locknuts
(Item 7, Table 29, WP 0062 00)
Starter ground terminal lockwasher
(Item 8, Table 29, WP 0062 00)
Two transmission modulator clamp locknuts
(Item 9, Table 29, WP 0062 00)
Accelerator rod locknut

Personnel Required

Three assistants

Equipment Condition

Horn wire removed (TM 9-2320-283-20)
Grille shell removed (TM 9-2320-283-20)
Fenders removed (TM 9-2320-283-20)
Upper radiator fan shroud removed
(TM 9-2320-283-20)
Steering system to proper level removed
(TM 9-2320-283-20)
Transmission oil cooler lines removed
(TM 9-2320-283-20)
Air reservoir draincocks opened
(TM 9-2320-283-20)
Bumper and towing eyes removed
(TM 9-2320-283-20)
Brush guard and spotter mirrors removed
(TM 9-2320-283-20)

BIG CAM III ENGINE INSTALLATION (Contd)

1. Attach two lifting brackets, lifting sling, and lifting device to engine (4).

WARNING

Use extreme care when handling heavy parts. Provide adequate support and use assistance during procedure. Ensure that any lifting device used is in good operating condition and of suitable load capacity. Keep clear of heavy components supported only by lifting device. Failure to comply may result in death or injury to personnel.

Use pry bars to free engine hangups or snags. Do not use hands. Failure to comply may result in injury to personnel.

NOTE

Use drift pin to aid in alignment of the engine to the transmission.

2. Using lifting device and lifting sling, lower engine (4) on frame (1). Ensure that engine and transmission are properly aligned and there is proper clearance between frame (1) and alternator (11) and between frame (1) and power steering pump (5).
3. Install transmission (12) to flywheel housing (21) with twelve bolts (13). Tighten bolts (13) 16 lb-ft (21 N•m).
4. Install engine brackets (3) on frame (1) with four bolts (2), washers (15), insulators (16), and nuts (14). Tighten nuts (14) 130–166 lb-ft (176–225 N•m).
5. Install front engine crossmember mount (8) on frame (1) with two bolts (9), four washers (6), two insulators (7), and nuts (10). Tighten nuts (10) 130–166 lb-ft (176–225 N•m).
6. Remove lifting sling and lifting device from engine lifting brackets (18) and remove transmission jack from transmission (12).

NOTE

Rotate accessory drive pulley nut to gain access to flywheel bolts.

7. Install flywheel (19) on torque converter (20) with twelve bolts (24) and washers (23). Tighten bolts (24), 19–21 lb-ft (26–29 N•m).
8. Install P-clamp (17) and flywheel bolt access cover (18) on flywheel housing (21) with two screws (25).
9. Connect ether quick-start tube (27) to atomizer (28) on intake manifold (26).

BIG CAM III ENGINE INSTALLATION (Contd)

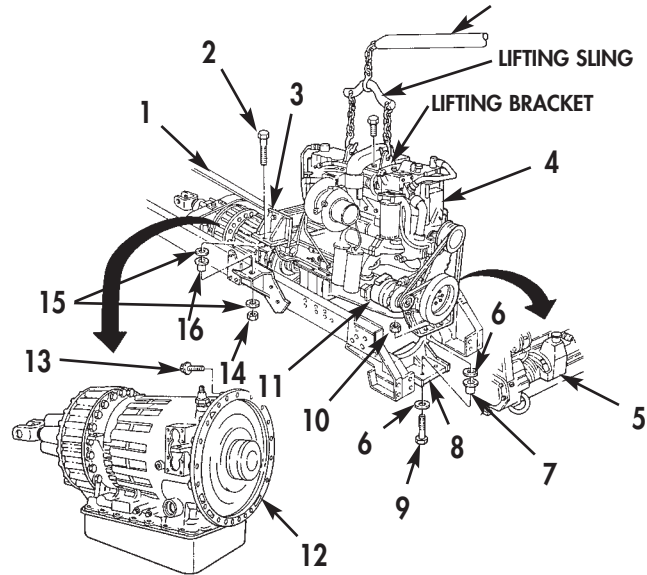


Figure 1. Engine Assembly on Frame.

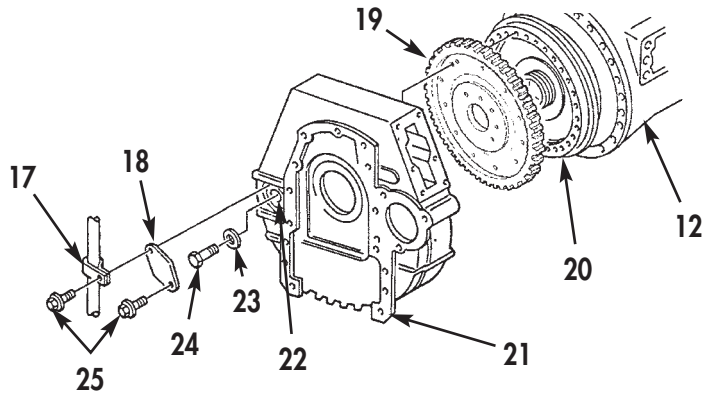


Figure 2. Flywheel Housing Assembly.

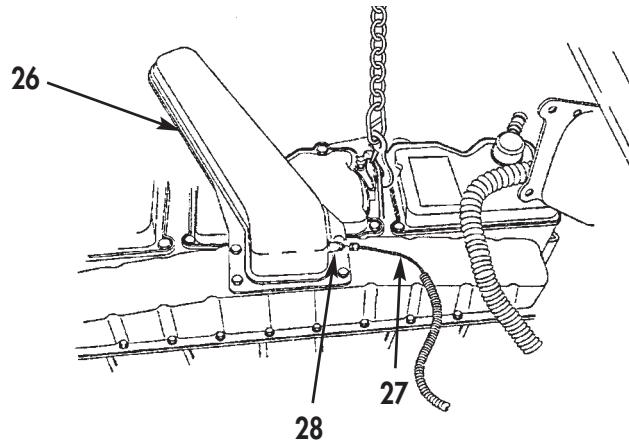


Figure 3. Connecting Quick Start Tube.

BIG CAM III ENGINE INSTALLATION (Contd)

10. Connect transmission TPS harness electrical connector (2) to vehicle TPS harness electrical connector (1).
11. Connect front (4), middle (5), and rear (6) jacob brake electrical connectors to cylinder heads (3).
12. Connect jacob brake electrical connector (7) to engine harness electrical connector (8).

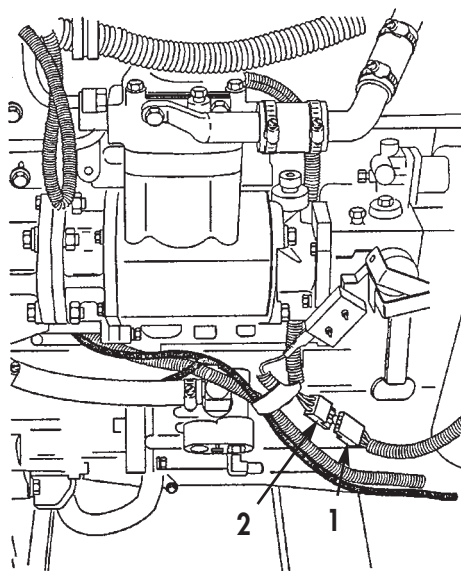


Figure 4. Transmission TPS Electrical Connectors.

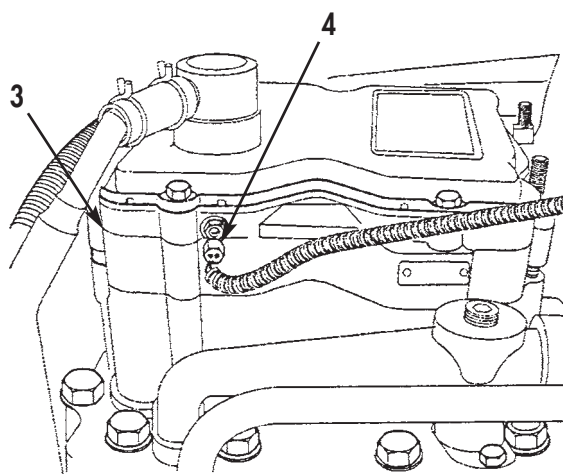


Figure 5. Front Jacob Brake Electrical Connector.

BIG CAM III ENGINE INSTALLATION (Contd)

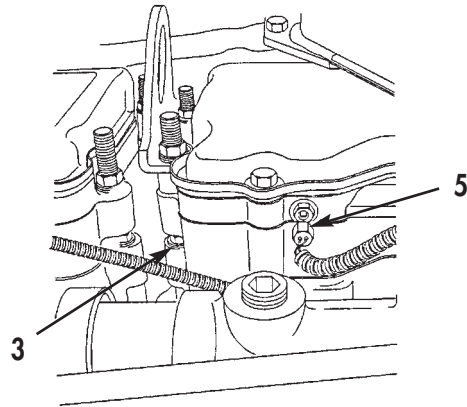


Figure 6. Middle Jacob Brake Electrical Connectors.

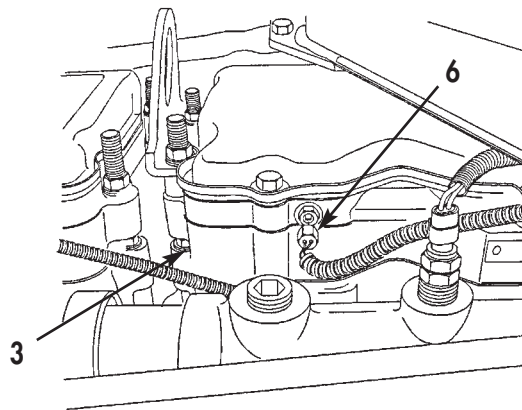


Figure 7. Rear Jacob Brake Electrical Connectors.

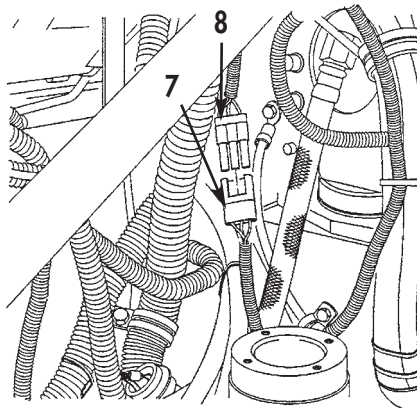


Figure 8. Jacob Brake Harness Installation.

BIG CAM III ENGINE INSTALLATION (Contd)

13. Connect fuel pump pressure sensor electrical connector (6) to fuel pump pressure sensor (5).
14. Install fuel solenoid electrical harness lead (4) on fuel solenoid (1) with fuel solenoid terminal lockwasher (2) and nut (3).
15. Install A/C electrical harness ground lead (16) and ground jumper cable (17) on engine (19) with two new A/C electrical harness ground lead starwashers (15), and screw (18).
16. Install battery ground cable (27), starter electrical harness lead no. 83 (26) and ground jumber cable (17) on starter ground terminal (25) with new starter ground terminal lockwasher (8) and nut (7).
17. Install battery positive cable (10) and three starter electrical harness leads no. 202 (12), no. 82 (13), and no. 421 (14) on starter positive terminal (24) with new starter positive terminal lockwasher (11) and nut (9).
18. Install starter electrical harness lead no. 74 (22) on starter S-terminal (23) with starter S-terminal lockwasher (20) and nut (21).

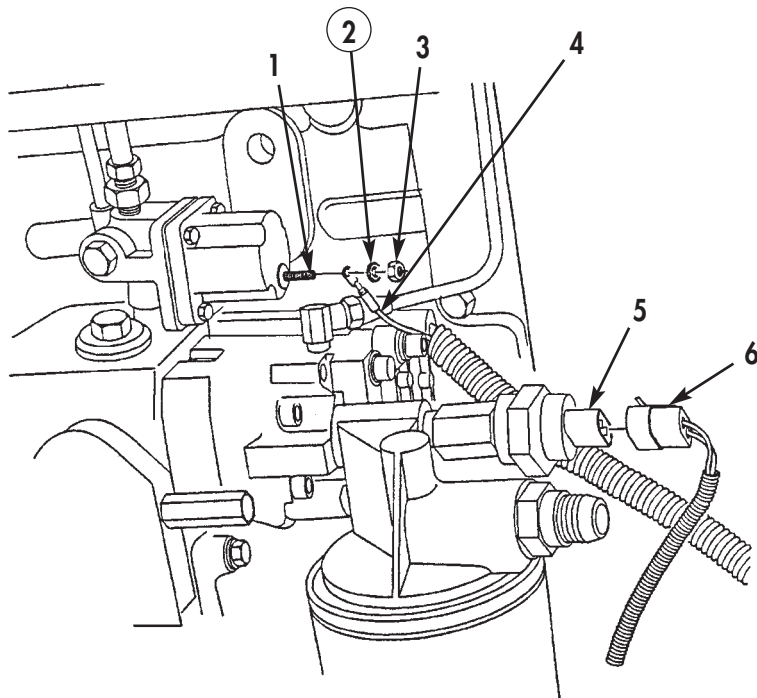


Figure 9. Fuel Solenoid and Pressure Sensor Wiring Installation.

BIG CAM III ENGINE INSTALLATION (Contd)

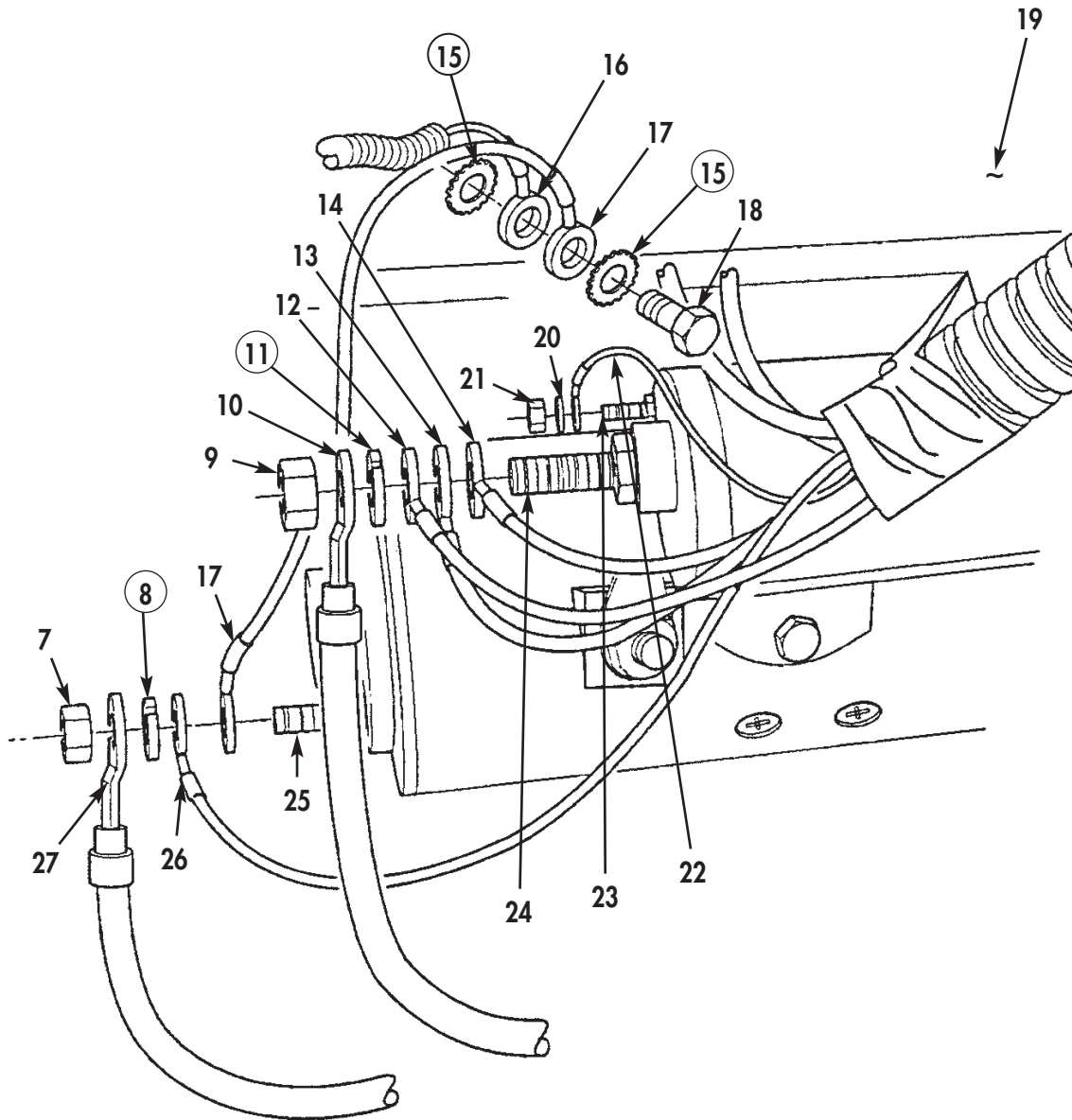


Figure 10. Starter Motor Electrical Connections Installation.

BIG CAM III ENGINE INSTALLATION (Contd)**NOTE**

Thread cables and wires through grommet before installing wires.

19. Install 12V power lead (7) and two engine harness leads (5) and (6) on 12V power stud (2) with 12V power stud washer (3), nut (4), and grommet (1).
20. Install pressure harness lead (16) and fan solenoid lead (15) on fan temperature switch (17) terminal B with fan temperature switch washer (9) and screw (10).
21. Install pressure harness lead (13) and engine harness lead (14) on fan temperature switch (17) terminal A with fan temperature switch washer (12) and screw (11).
22. Connect temperature sensor electrical connector (8) to temperature sensor (18).

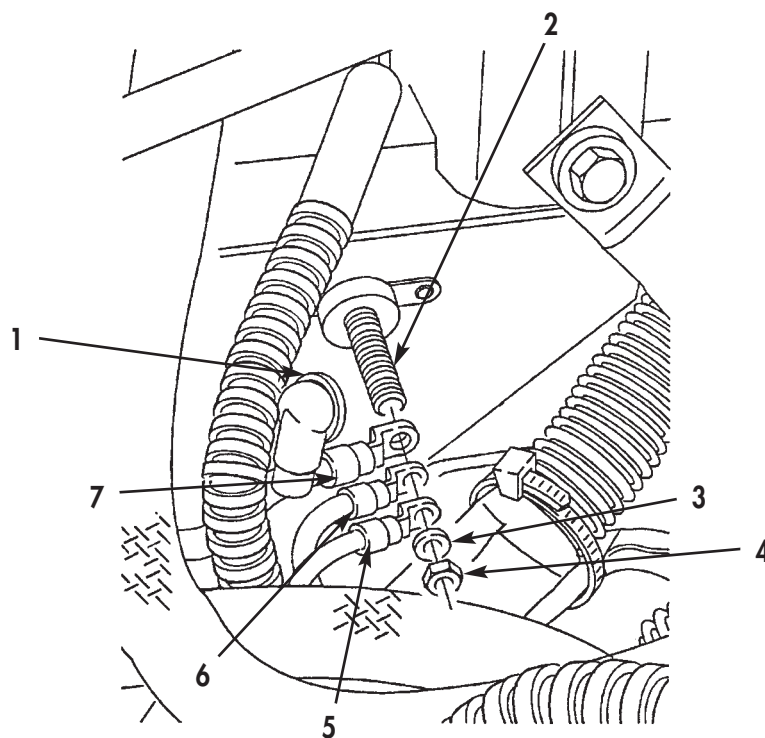


Figure 11. 12V Harness Leads Installation.

BIG CAM III ENGINE INSTALLATION (Contd)

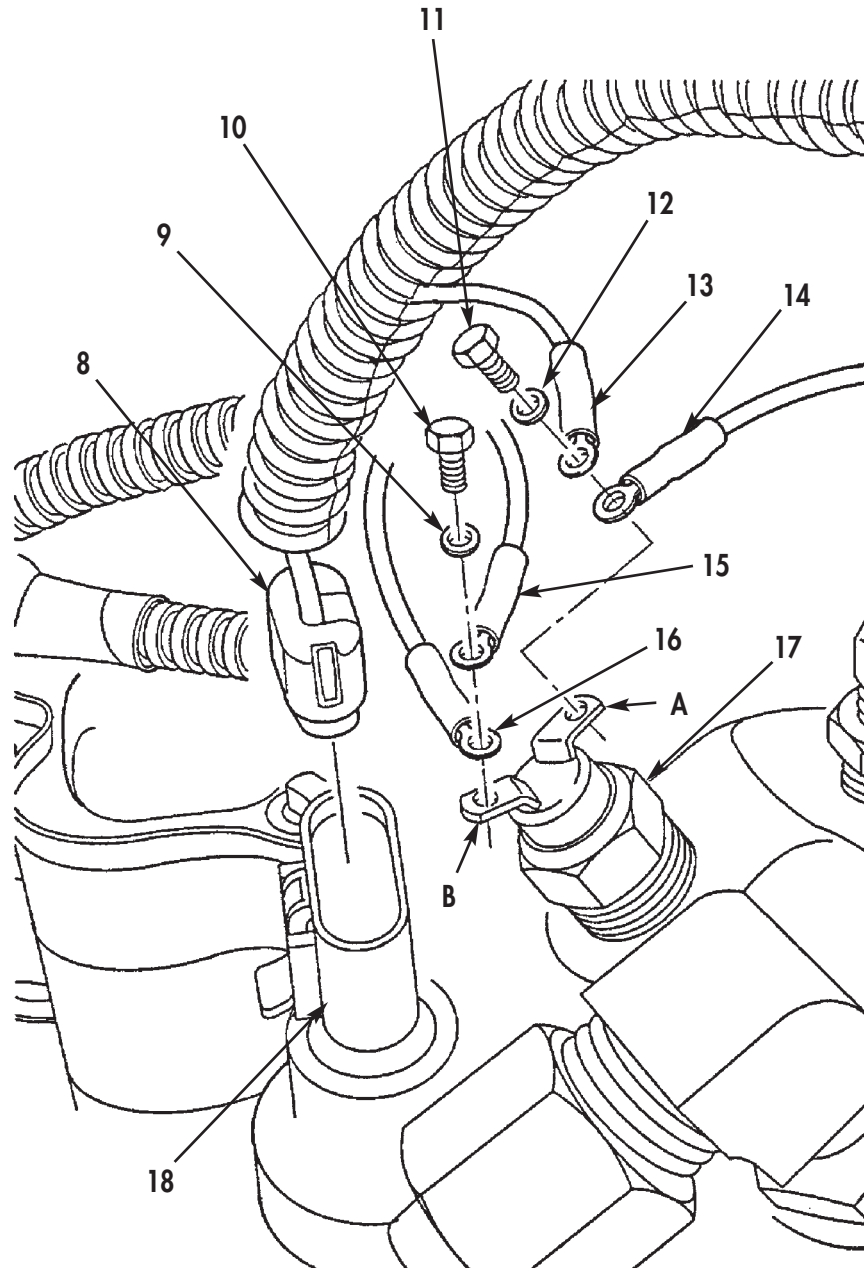


Figure 12. Fan Temperature Switch Electrical Connections.

BIG CAM III ENGINE INSTALLATION (Contd)

23. Install engine electrical harness transformer/rectifier negative lead (16) on alternator transformer/rectifier negative terminal (14) with alternator terminal washer (7) and nut (6).
24. Install engine electrical harness transformer/rectifier positive lead (8) on alternator transformer/rectifier positive terminal (15) with alternator terminal washer (5) and nut (4).
25. Install engine electrical harness negative lead (3) on alternator negative terminal (10) with alternator terminal washer (2) and nut (1).
26. Install engine electrical harness positive lead (9) on alternator positive terminal (11) with alternator terminal washer (12) and nut (13).
27. Install two drive belts (21) on alternator (22), drive pulley (25), and crankshaft pulley (26).
28. Tighten jamnut (17) on adjusting rod (24) until tension on drivebelts (21) is 110 lbs (50 kg).
29. Tighten jamnut (23).
30. Tighten two alternator mounting bracket nuts (20) (hidden) and screws (19).

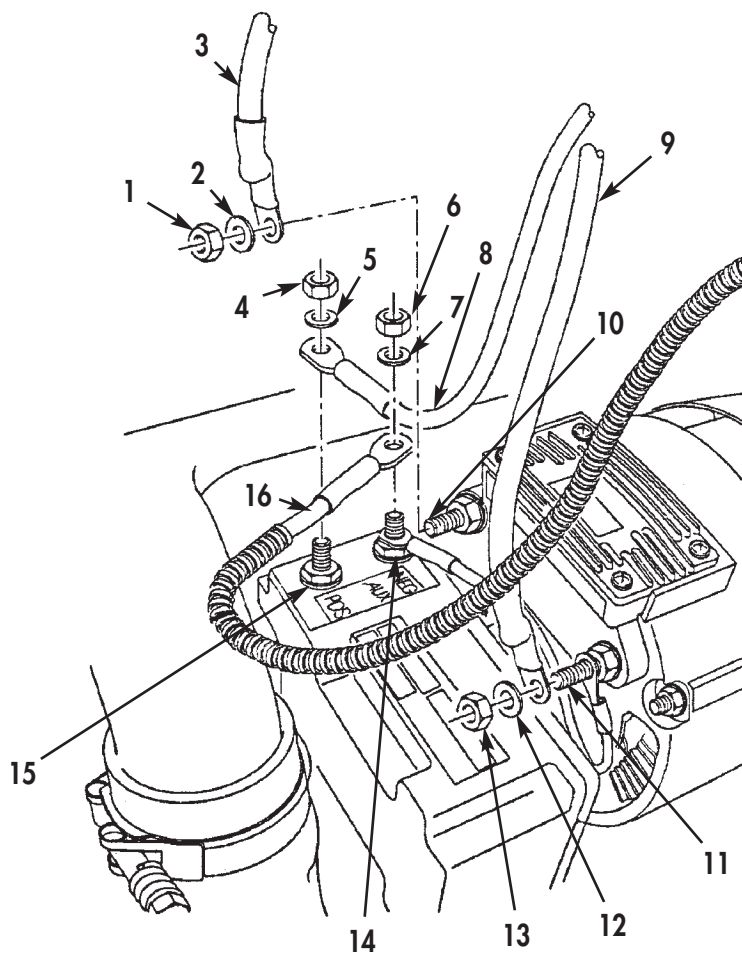


Figure 13. Alternator Electrical Connections Installation.

BIG CAM III ENGINE INSTALLATION (Contd)

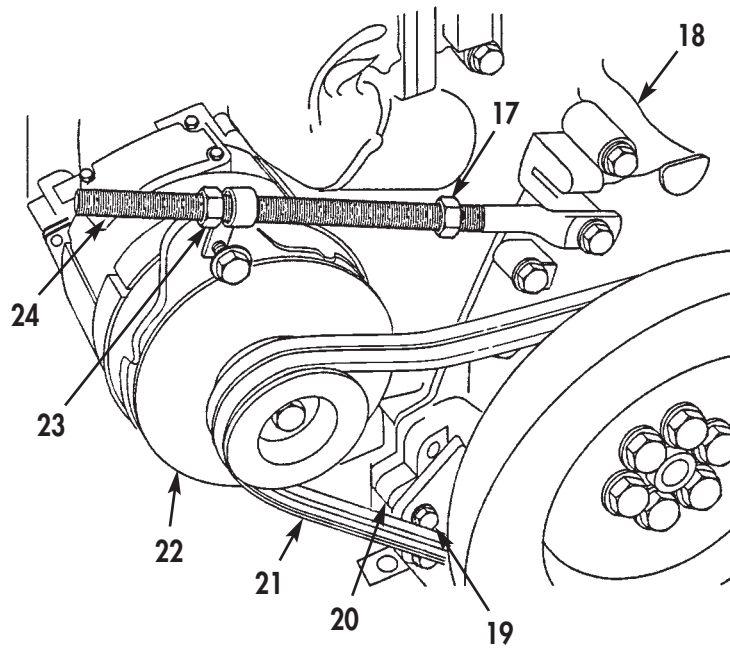


Figure 14. Alternator Belt Installation.

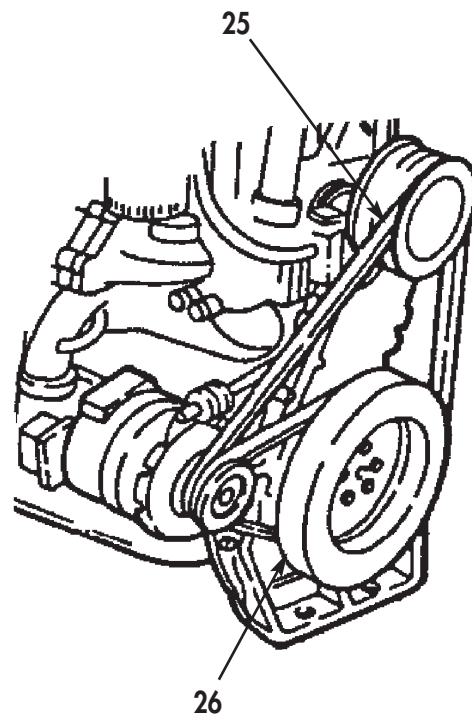


Figure 15. Drive Pulley and Camshaft Pulley Installation.

BIG CAM III ENGINE INSTALLATION (Contd)

31. Connect control valve module electrical harness (6) to transmission electrical harness (2).
32. Install transmission electrical harness (2) on transmission (1) with transmission electrical harness clamp (3), two washers (5), screw (4), and nut (7).
33. Connect output speed sensor electrical connector (8) to output speed sensor (9).
34. Connect turbine speed sensor electrical connector (12) on turbine speed sensor jumper harness (13).
35. Connect engine speed sensor electrical connector (11) to engine speed sensor (10).
36. Install transmission oil temperature sensor electrical connector (14) on transmission oil temperature sensor (15) with transmission oil temperature sensor electrical connector washer (16) and nut (17).

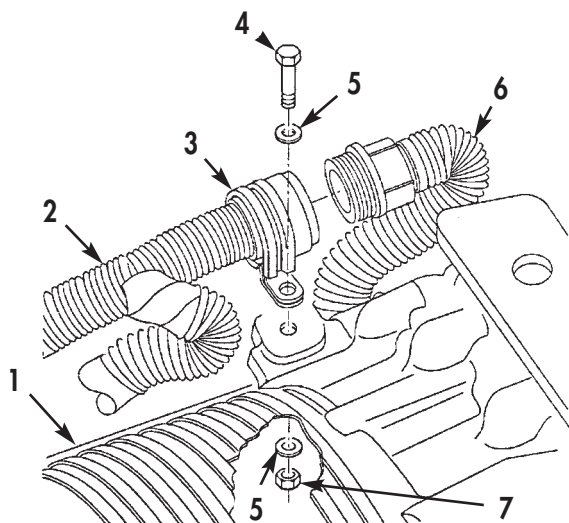


Figure 16. Transmission Electrical Harness Installation.

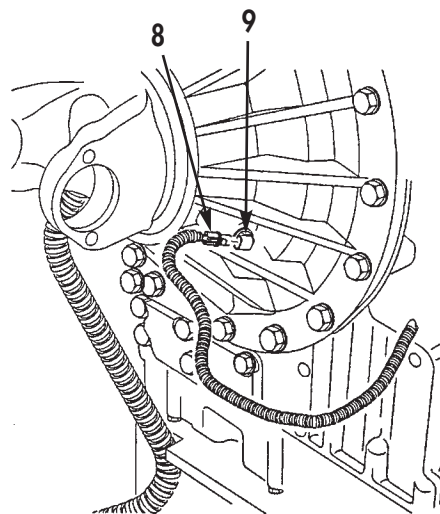


Figure 17. Output Speed Sensor Installation.

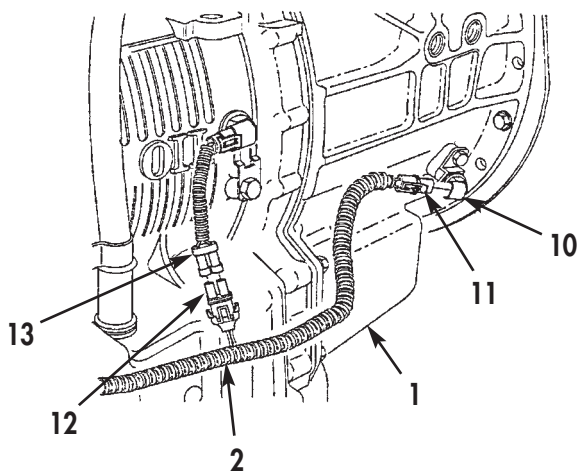


Figure 18. Engine Speed and Turbine Sensors Installation.

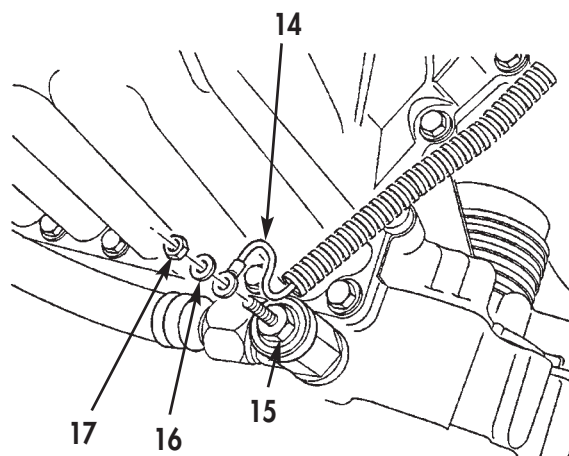


Figure 19. Transmission Oil Temperature Sensor Installation.

BIG CAM III ENGINE INSTALLATION (Contd)

37. Connect two transmission oil cooler hoses (18) and (20) to transmission (19).
38. Install transmission oil cooler hoses (18) and (20) on transmission oil cooler base mounting bracket (23) with transmission oil cooler hose clamp (25), washer (21), screw (24), and nut (22).
39. Connect air line (27) to fan temperature switch (26).
40. Connect two air lines (28) to air compressor (29).
41. Connect oil sample hose (30) to elbow fitting (31) to oil filter housing (32).
42. Connect air compressor hose (33) on top of transmission (22) to air compression hose (34).

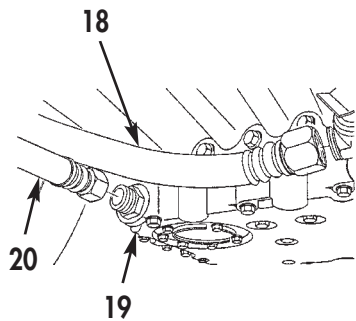


Figure 20. Oil Cooler Hoses Installation.

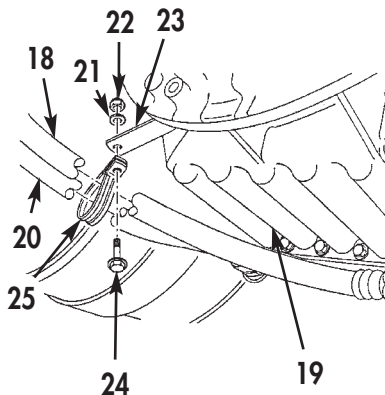


Figure 21. Transmission Oil Cooler Hose Clamp Installation.

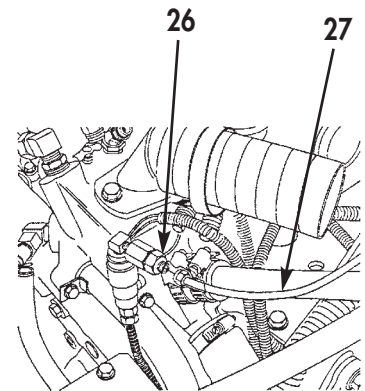


Figure 22. Fan Temperature Switch Installation.

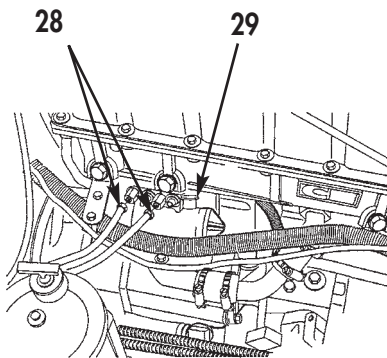


Figure 23. Air Compressor Lines Installation.

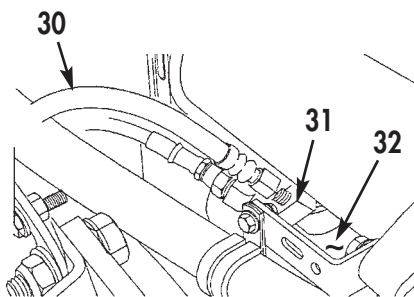


Figure 24. Engine Oil Sampling Hose Installation.

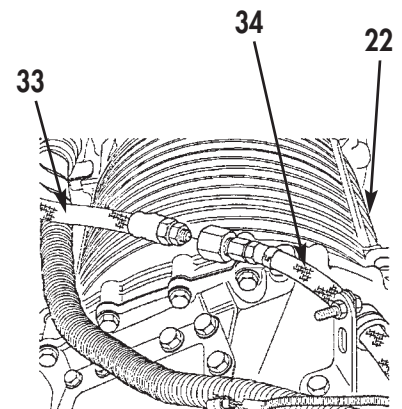


Figure 25. Air Compressor Hose Installation.

BIG CAM III ENGINE INSTALLATION (Contd)

43. Install tachometer cable (2) on fuel pump tachometer drive (1).
44. Install accelerator rod (16) on lower throttle lever (17) with accelerator rod screw (18), new locknut (20), and two accelerator return springs (19).
45. Align locating mark on transmission modulator cable clamp (5) to locating mark on mounting bracket (10).
46. Install transmission modulator cable (11) on mounting bracket (10) with transmission modulator cable clamp (5), two screws (6), four washers (9), and two new locknuts (14).
47. Install transmission modulator cable (11) on throttle lever (15) with retaining pin (3).
48. Install fuel supply line (12) on fuel filter fitting (13).
49. Install fuel return line (8) to fuel return line T-fitting (7) on engine (4).
50. Install power steering hose (21) on elbow (25) of power steering reservoir (23).
51. Install two power steering hoses (21) and clamps (22) on power steering reservoir (23) and power steering pump (26). Tighten clamps (22).
52. Install drain plug (24) in power steering reservoir (23).
53. Install cooling fan (30) on cooling fan clutch studs (31) with six new cooling fan lockwashers (28), washers (29), and nuts (27).

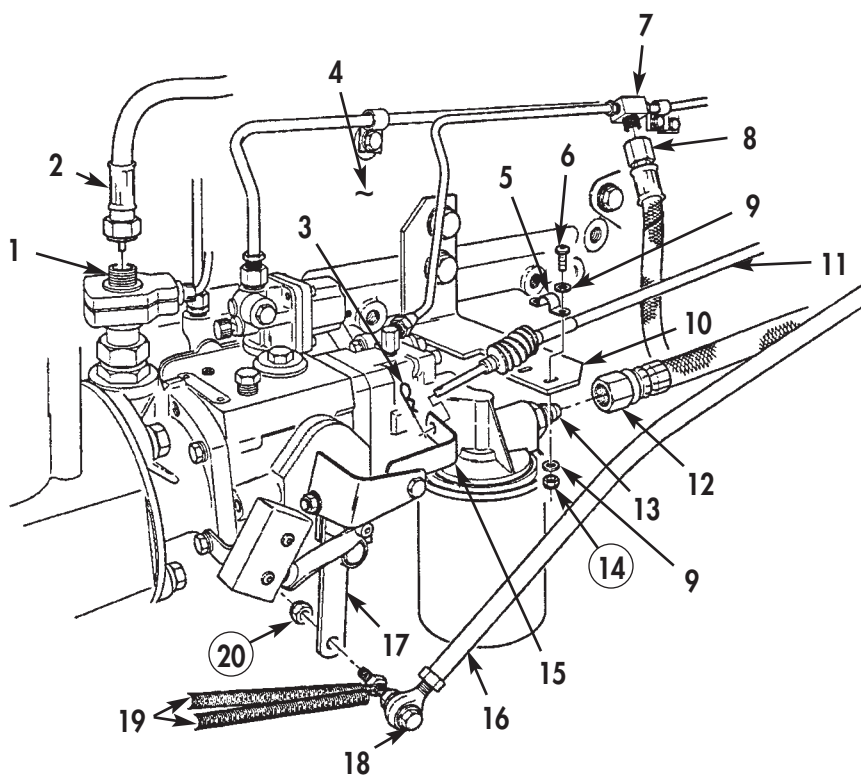


Figure 26. Throttle Lever Installation.

BIG CAM III ENGINE INSTALLATION (Contd)

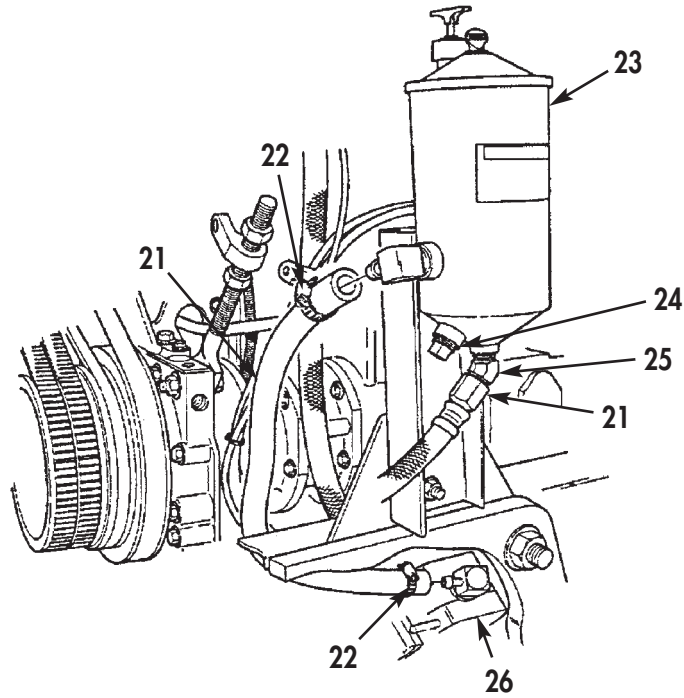


Figure 27. Power Steering Hoses Installation.

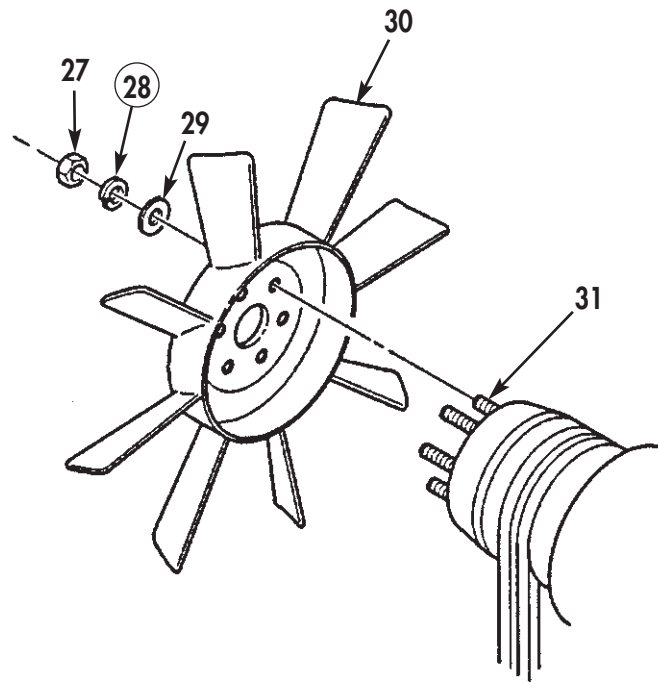


Figure 28. Cooling Fan Installation.

BIG CAM III ENGINE INSTALLATION (Contd)

54. Install two isolators (9) and washers (8) on top of front crossmember (11).
55. Install chains and lifting device on radiator (7).
56. Using lifting device and chains, install radiator (7) on front crossmember (11).
57. Secure radiator to front of crossmember (11) with two radiator crossmember mount isolators (9), washers (8), and new locknuts (10).
58. Install three radiator support rods (6) on radiator (7) and firewall brackets (1) with four radiator support rod screws (4), eight washers (3), four spacers (2), and new locknuts (5).
59. Install ground strap (14) on radiator (7) and frame front crossmember (11) with two ground strap isolators (15), washers (12), and new locknuts (13).
60. Remove chains and lifting device from radiator (7).

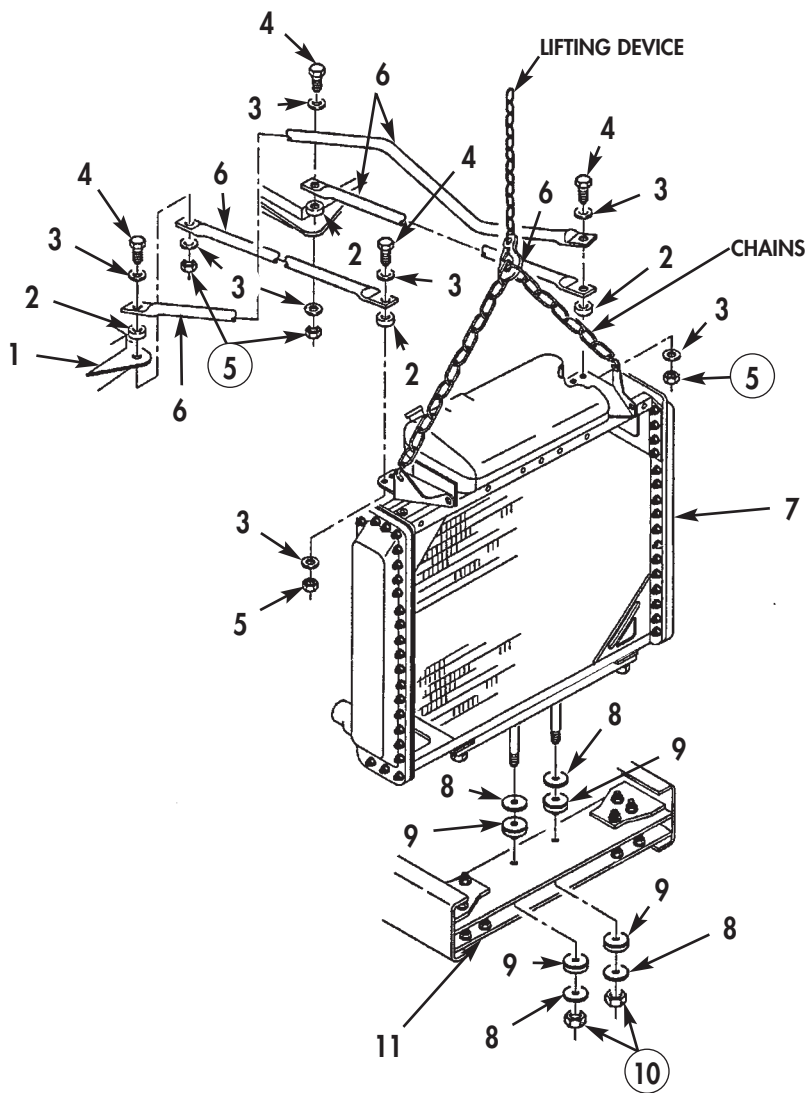


Figure 29. Radiator Installation.

BIG CAM III ENGINE INSTALLATION (Contd)

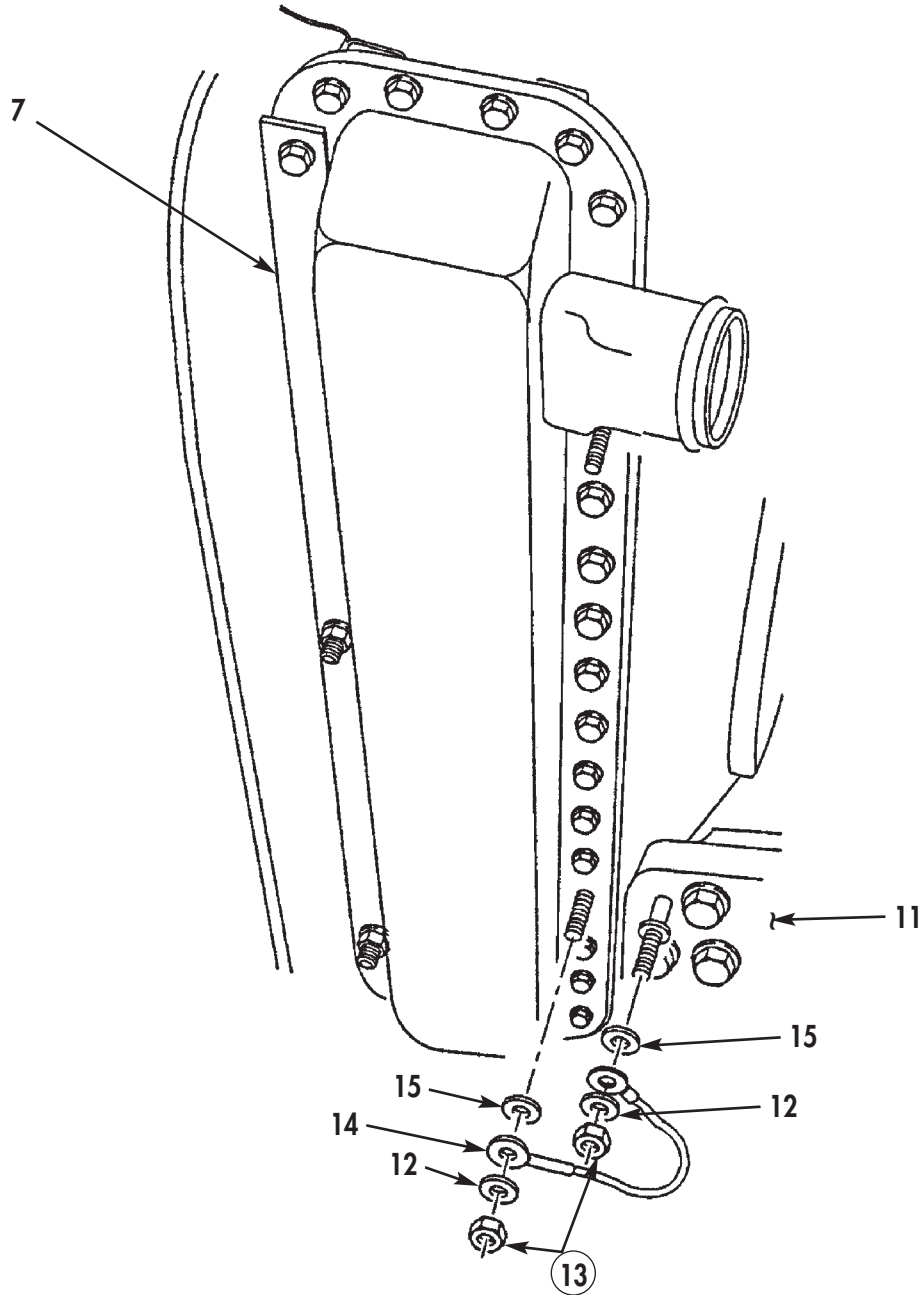


Figure 30. Radiator Ground Strap Installation.

BIG CAM III ENGINE INSTALLATION (Contd)

61. Install coolant temperature sender electrical connectors (5) on coolant temperature sender terminal (4) with coolant temperature sender terminal screw (1).
62. Install coolant temperature sender electrical connector (3) on coolant temperature sender terminal (4) with coolant temperature sender terminal nut (2).
63. Install A/C condensor (9) with A/C condensor lines (10) attached, on two support brackets (8) on front of radiator (15) with four new A/C condensor locknuts (7).
64. Install A/C condensor lines (10) on radiator support brackets (14) with three A/C condensor lines clamps (13), screws (6), washers (12), and new locknuts (11).

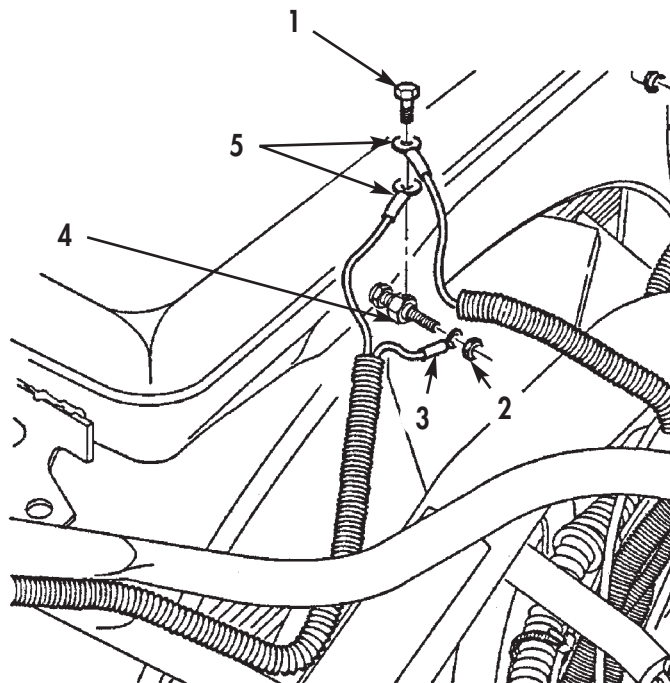


Figure 31. Coolant Temperature Sender Electrical Connectors Installation.

BIG CAM III ENGINE INSTALLATION (Contd)

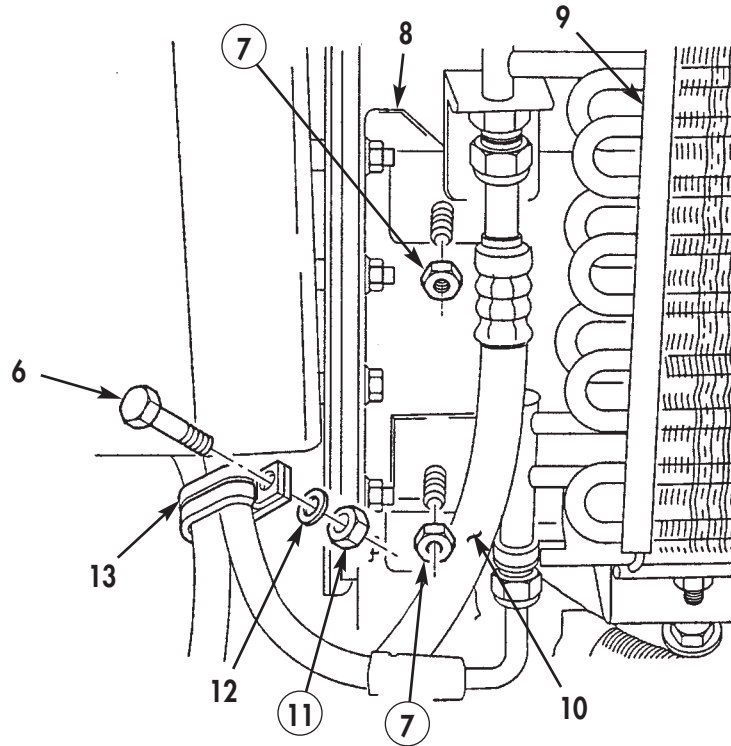


Figure 32. AC Condenser Hoses Installation.

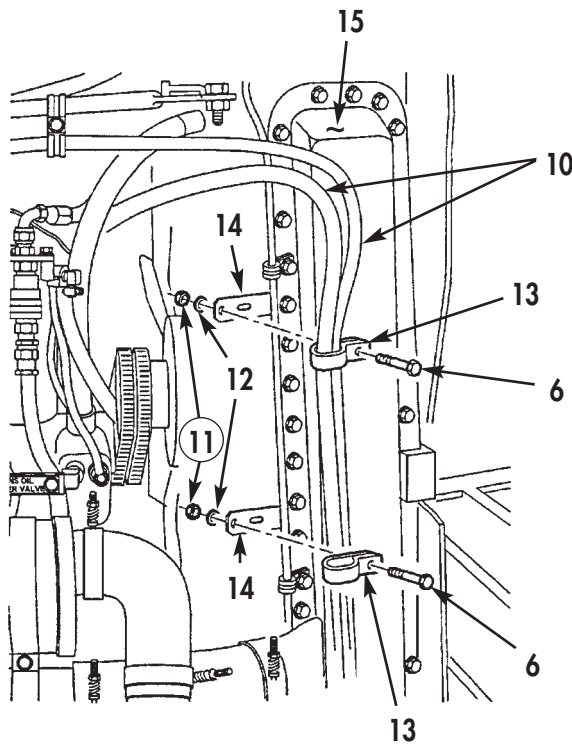


Figure 33. AC Condenser Lines Installation.

BIG CAM III ENGINE INSTALLATION (Contd)

65. Install A/C compressor (5) on mounting bracket (27) with two A/C compressor mounting bracket bolts (26), washers (24), and new locknuts (23).
66. Install A/C compressor adjusting rod (15) on front cover (16) with A/C compressor adjusting rod bolt (18), two washers (13), and new locknut (12).
67. Install A/C drive belt (19) on A/C clutch pulley (25) and accessory drive pulley (17).
68. Tighten two jam nuts (11) on A/C compressor adjusting rod (15) to obtain 0.50 in. (12.7 mm) A/C drive belt (19) deflection.
69. Install A/C compressor hose (4), clamp (1), screw (2), washer (22), and new locknut (21) on top of engine (20).
70. Install A/C compressor lines (3), two clamps (8) and (14), washers (10), and screws (9) on A/C compressor (5).
71. Connect A/C compressor clutch electrical connector (7) to engine wiring harness (6).

BIG CAM III ENGINE INSTALLATION (Contd)

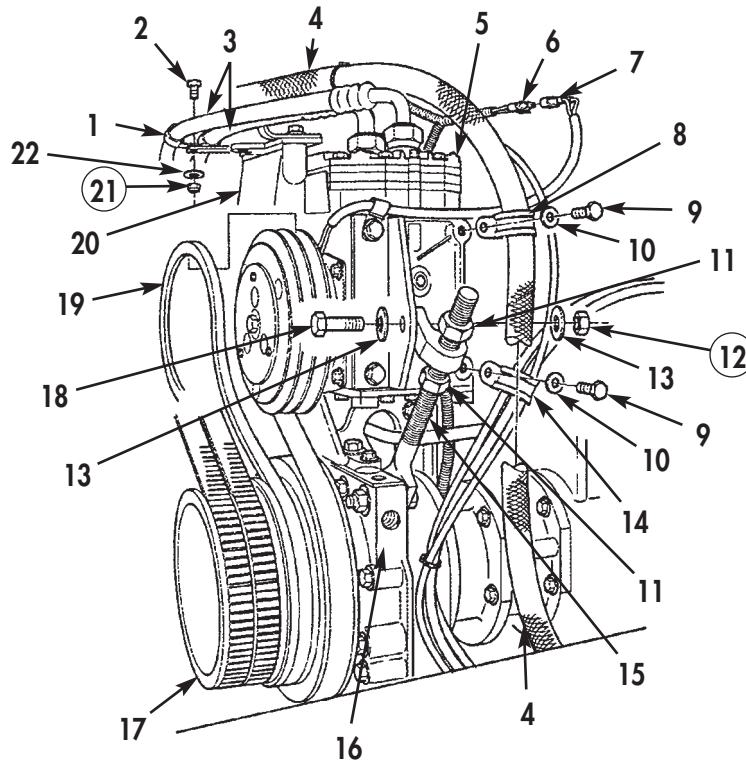


Figure 34. AC Compressor Mounting Bracket Installation.

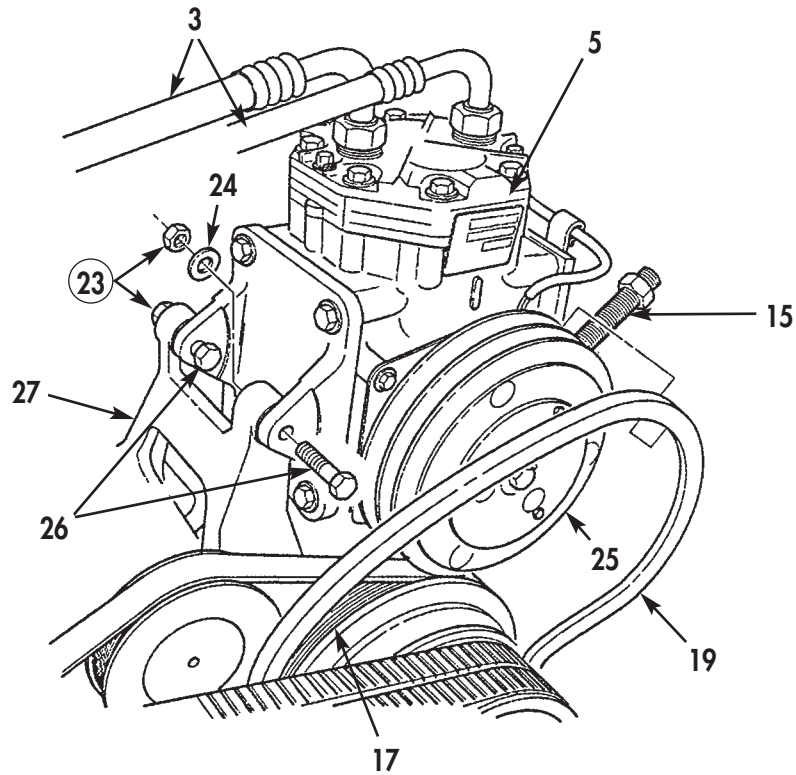


Figure 35. AC Compressor Mounting Bolts Installation.

BIG CAM III ENGINE INSTALLATION (Contd)

72. Install upper radiator hose (9) and two upper radiator hose clamps (7) on thermostat housing elbow (8) and radiator inlet tube (1). Tighten upper radiator hose clamps (7).
73. Install cooling outlet tube (16) and three clamps (11) on water pump (17). Tighten clamps (11).
74. Secure cooling tube outlet on support bracket (12) with cooling tube outlet screw (14) and nut (13).
75. Install lower radiator hose (15) and two lower radiator hose clamps (10) on radiator (2). Tighten clamps (10).
76. Install bypass hose (6) and clamp (5) on radiator (2). Tighten clamp (5).
77. Install two vent hoses (4) and clamps (3) on radiator (2). Tighten clamps (3).
78. Install heater hose (23) and clamp (22) on heater hose tube adapter (21). Tighten clamp (22).
79. Install heater hose (18) and clamp (19) on heater hose tube (20). Tighten clamp (19).
80. Install exhaust S-pipe (28) and clamp (24) on exhaust pipe (30) with two exhaust pipe screws (25) and nuts (29).
81. Install exhaust S-pipe (28) and clamp (26) on turbocharger outlet flange (27). Tighten clamp (26).

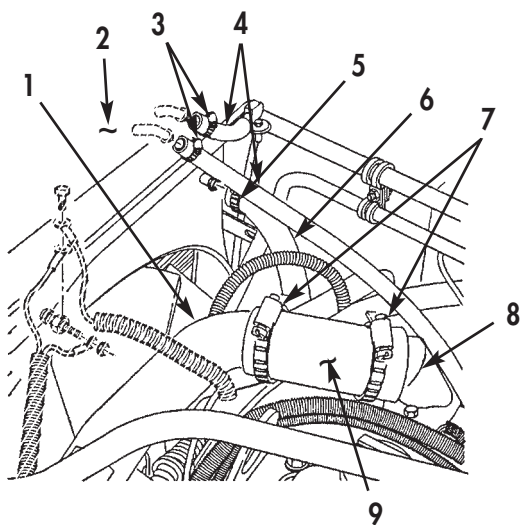


Figure 36. Upper Radiator Hose Installation.

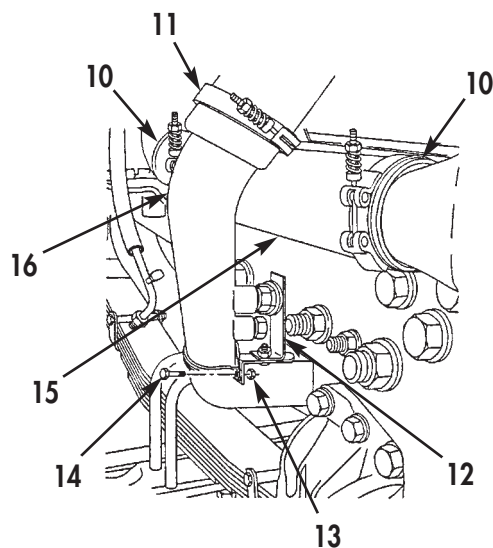


Figure 37. Lower Radiator Hose Installation.

BIG CAM III ENGINE INSTALLATION (Contd)

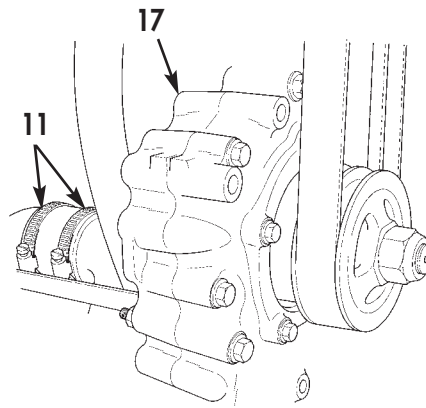


Figure 38. Water Pump Installation.

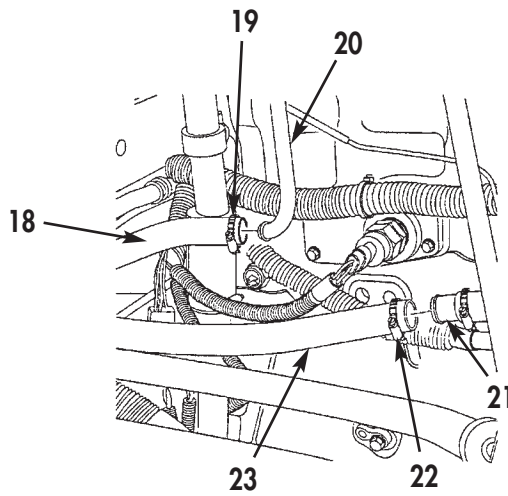


Figure 39. Heater Hose Installation.

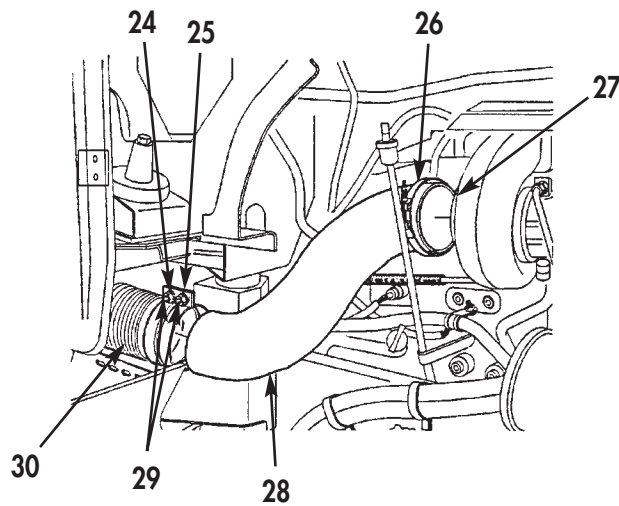


Figure 40. Turbocharger Hose Installation.

BIG CAM III ENGINE INSTALLATION (Contd)

82. Install adapter duct (3) on air cleaner box (4) with four reinforcement plates (7), ten adapter duct screws (1), washers (5) and (2), and new locknuts (6).
83. Connect air duct door spring (12) on air duct door (9) and firewall (4).
84. Install air cleaner housing (8) on adapter duct (3) with six air cleaner housing washers (10) and new locknuts (11).
85. Install indicator tube (19) and elbow (18) on air cleaner housing (8).
86. Install air vent hose (17), two air vent hose clamps (16) on air duct support bracket (20) with four air cleaner housing bracket screws (22), washers (23), and new locknuts (24). Tighten clamps (16).
87. Install air vent tube (13) on air duct support bracket (20) with vent tube screw (14), washer (15), and locknut (21).
88. Install air cleaner duct assembly (29) and three clamps (28) on turbocharger outlet (30), outlet elbow (27), and air cleaner housing (8). Tighten clamps (28).
89. Install outlet elbow (27) on air chamber (31).
90. Install new air cleaner element (26) and three clamps (25) on air cleaner housing (8). Tighten clamps (25).

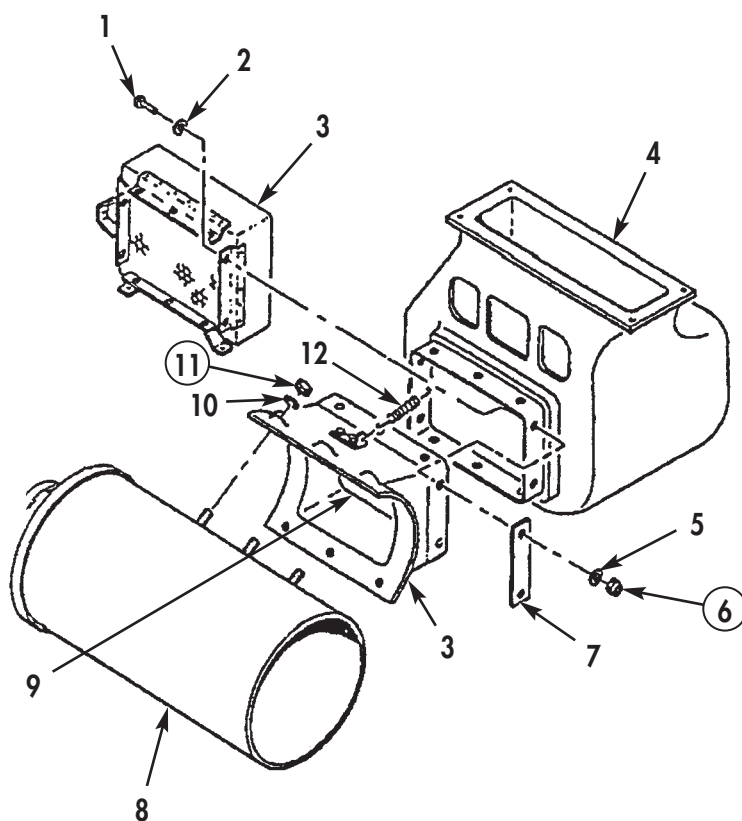


Figure 41. Air Cleaner Housing Installation.

BIG CAM III ENGINE INSTALLATION (Contd)

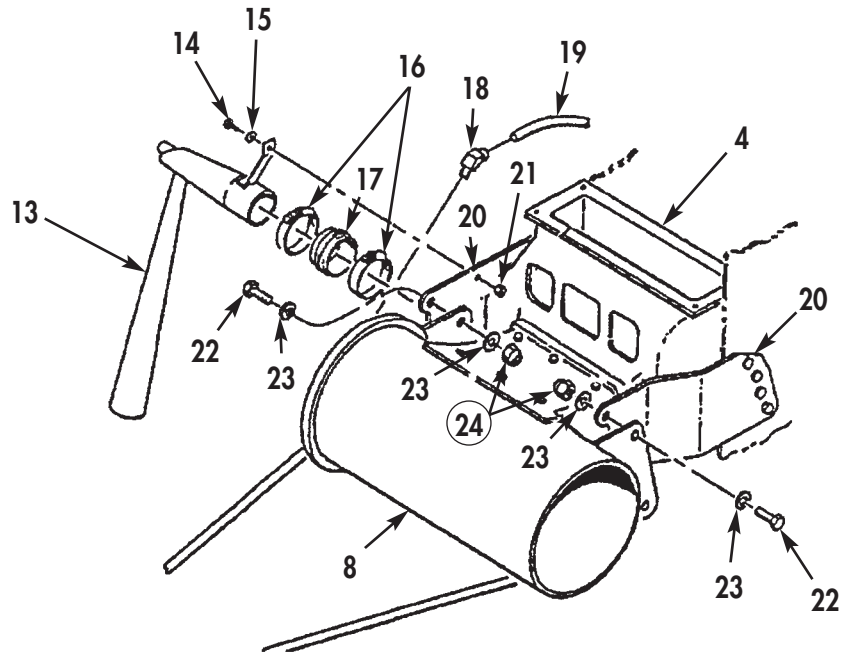


Figure 42. Air Duct Installation.

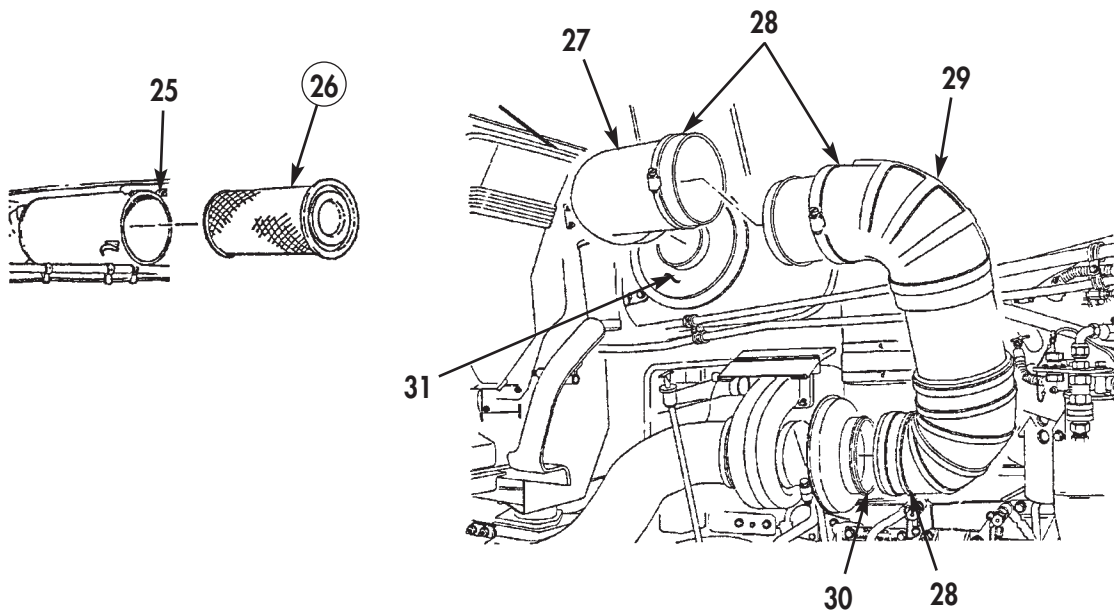


Figure 43. Air Cleaner Installation.

BIG CAM III ENGINE INSTALLATION (Contd)**NOTE**

Use three assistants or lifting strap and lifting device to install hood to vehicle.

91. Install hood (3) on hood hinges (4) with two hood hinge bolts (2) and new locknuts (1).

WARNING

When installing hood tilt assist cables, hood must be supported. Failure to do so may result in damage to equipment or injury to personnel.

92. Support hood (3) and install two tilt assist cables (5) connected to chain links (6) on chain links nuts (7).
93. Install lighting harness (13) on hood (3) with four lighting harness clamps (8), washers (9), screws (10), and new plastic tie (12).
94. Connect four electrical connectors (11) to lighting harness (13).

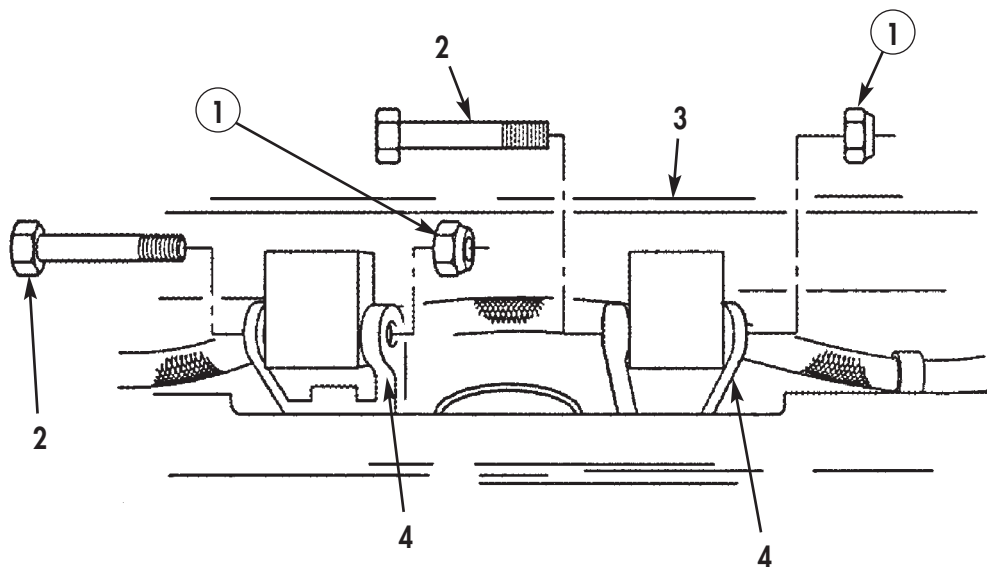


Figure 44. Hood Hinge Installation.

BIG CAM III ENGINE INSTALLATION (Contd)

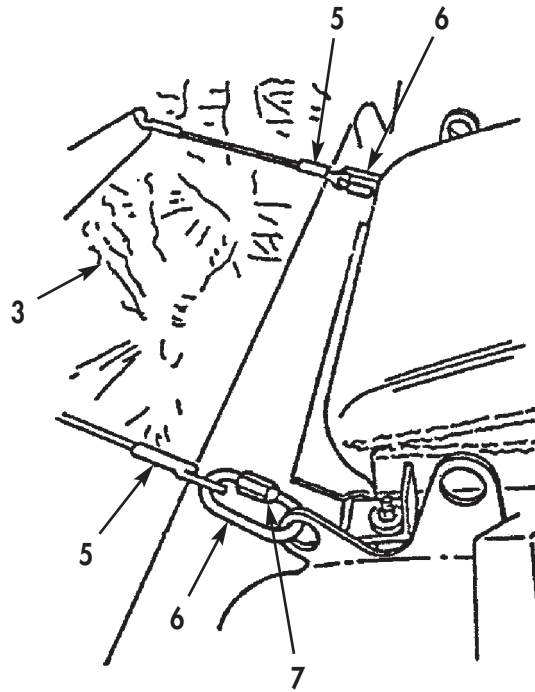


Figure 45. Tilt Assist Cables Installation.

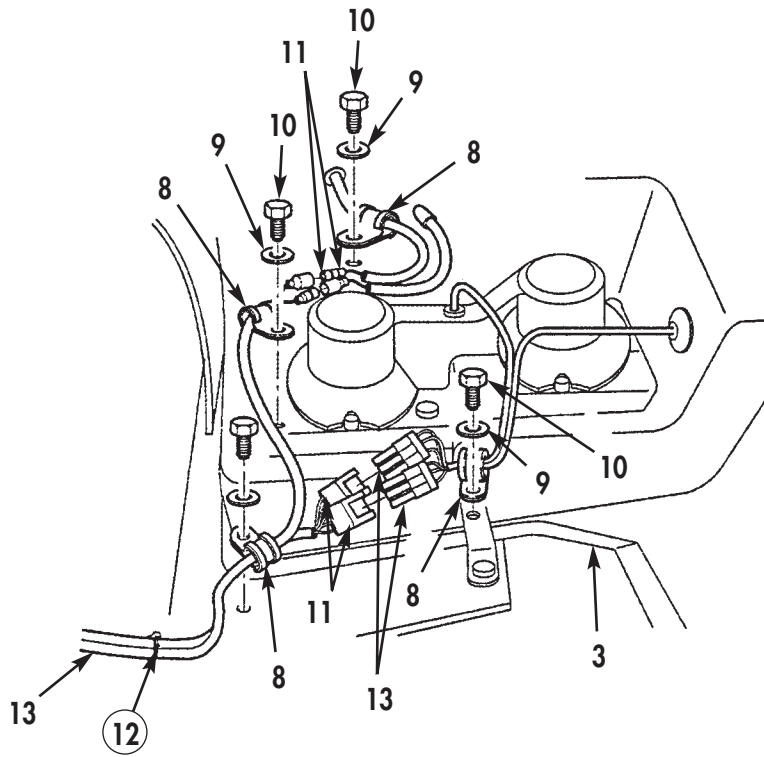


Figure 46. Lighting Harness Installation.

BIG CAM III ENGINE INSTALLATION (Contd)

95. Fill cooling system with coolant to specified level (TM 9-2320-283-10).
96. Fill transmission with transmission oil to specified level (TM 9-2320-283-10).
97. Fill engine crankcase with engine oil to specified level (TM 9-2320-283-10).
98. Fill steering system with steering fluid to specified level (TM 9-2320-283-10).
99. Install negative battery cable (1) on battery (4) and connect two negative battery cable clamps (2) on two negative battery cable post (3).
100. Install brush guard and spotter mirrors (TM 9-2320-283-20).
101. Install bumper and towing eyes (TM 9-2320-283-20).
102. Install transmission oil cooler lines (TM 9-2320-283-20).
103. Close air reservoir draincocks (TM 9-2320-283-20).
104. Install upper radiator fan shroud (TM 9-2320-283-20).
105. Install fenders (TM 9-2320-283-20).
106. Install grill shell (TM 9-2320-283-20).
107. Install horn wire (TM 9-2320-283-20).

CAUTION

Always perform break-in procedures for a new or repaired engine to prevent premature bearing and ring failure.

108. Perform engine testing (WP 0047 00).

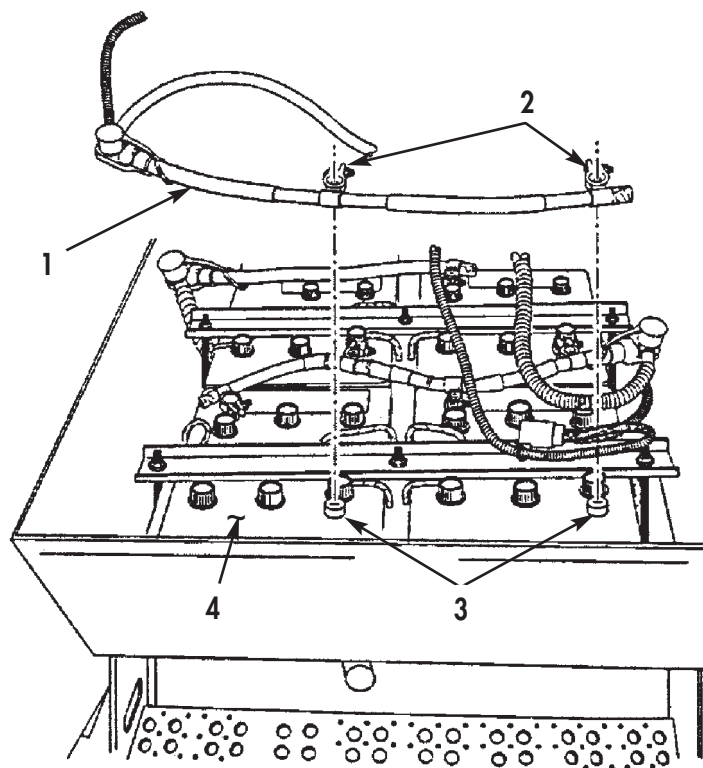


Figure 47. Battery Cable Installation.

**DIRECT SUPPORT AND GENERAL SUPPORT
MAINTENANCE MANUAL
INCLUDING REPAIR PARTS AND SPECIAL TOOLS LIST (RPSTL)**

FOR

M915, M915A1, M915A4, M916, M920 VEHICLES

NSN 2815-01-082-8125	P/N NTC400-3652-02	CUMMINS NTC-400 BIG CAM I DIESEL ENGINE W/CONTAINER
NSN 2815-01-142-2745	P/N 11669835	CUMMINS NTC-400 BIG CAM III DIESEL ENGINE W/CONTAINER

BIG CAM I ENGINE INSTALLATION

INITIAL SETUP:

Tools and Special Tools

General mechanic's tool kit: automotive
(Item 1, WP 0061 00)
Maintenance and repair shop equipment:
automotive (Item 2, WP 0061 00)
Lifting sling (Item 42, WP 0061 00)
Lifting brackets (Item 43, WP 0061 00)

Materials/Parts

Ground strap starwasher
(Item 1, Table 30, WP 0062 00)
Alternator adjusting rod lockwasher
(Item 2, Table 30, WP 0062 00)
Drive belts (Item 3, Table 30, WP 0062 00)
Trunion retaining pin
(Item 4, Table 30, WP 0062 00)
Two starter motor terminal lockwashers
(Item 5, Table 30, WP 0062 00)
Two transmission shift control cable
lockwashers (Item 6, Table 30, WP 0062 00)
Two transmission shift control cable locknuts
(Item 7, Table 30, WP 0062 00)
Two transmission modulator control bracket
lockwashers (Item 8, Table 30, WP 0062 00)
Transmission modulator control link retaining
pin (Item 9, Table 30, WP 0062 00)
Plastic tie (Item 10, Table 30, WP 0062 00)

Equipment Condition

Horn wire removed (TM 9-2320-283-20)
Grille shell removed (TM 9-2320-283-20)
Fenders removed (TM 9-2320-283-20)
Upper radiator fan shroud removed
(TM 9-2320-283-20)
Steering system to proper level removed
(TM 9-2320-283-20)
Transmission oil cooler lines removed
(TM 9-2320-283-20)
Air reservoir draincocks opened
(TM 9-2320-283-20)
Bumper and towing eyes removed
(TM 9-2320-283-20)
Brush guard and spotter mirrors removed
(TM 9-2320-283-20)

Personnel Required

Two assistants

BIG CAM I ENGINE INSTALLATION (Contd)

1. Attach two lifting brackets (4) with four bolts (3), lifting sling, and lifting device to engine (5).

WARNING

Use extreme care when handling heavy parts. Provide adequate support and use assistance during procedure. Ensure that any lifting device used is in good operating condition and of suitable load capacity. Keep clear of heavy components supported only by lifting device. Failure to do so may result in death or injury to personnel.

Use pry bars to free engine hangups or snags. Do not use hands. Failure to do so may result in damage to equipment or death or injury to personnel.

2. Using lifting device, lifting sling, and assistant, position engine over vehicle frame (22).
3. Position two rear vibration insulators (23) and rear frame flat washers (24) on rear frame engine mounting brackets (2).
4. Position two front vibration insulators (7) and front frame flat washers (6) on front engine crossmember (11).
5. Using lifting device and lifting sling, lower engine (5) into vehicle frame (22). Ensure there is proper clearance between power steering pump (8) and alternator (13) during lowering of engine (5).

NOTE

Use suitable drift pin to align mounting holes as necessary.

6. Secure engine (5) to two rear engine mounts (2) with two rear engine mount bolts (1), washers (16), and nuts (15). Tighten nuts (15) finger-tight.
7. Secure engine (5) to front engine crossmember (2) with two front engine mount washers (9), bolts (10), and nuts (12). Tighten nuts (12) finger-tight.
8. Remove lifting device, lifting sling, and lifting brackets (4) from engine (5).

NOTE

Rotate engine using accessory drive pulley nut to install flywheel bolts.

9. Using suitable drift pin and transmission jack, align transmission mounting holes (14) to flywheel housing mounting holes and install twelve transmission bolts (17). Tighten bolts (17) 60 lb-ft (80 N•m).
10. Attach ring gear (29) to flywheel (28) with twelve flywheel washers (32) and bolts (33) through flywheel bolt access hole (31). Alternately tighten bolts (33) 42–48 lb-ft (57–65 N•m).
11. Tighten two rear engine mount nuts (15) 270–295 lb-ft (366–400 N•m).
12. Tighten two front engine mount nuts (12) 270–295 lb-ft (366–400 N•m).
13. Install transmission temperature sender electrical connector (19), washer (20), and nut (21) on transmission temperature sender (18).
14. Position breather tube clamp (25) and install flywheel bolt access cover (26) on flywheel housing (30) with two flywheel bolt access cover screw (34). Tighten screws (34) 15–20 lb-ft (20–27 N•m).
15. Remove transmission jack from under transmission (27).

BIG CAM I ENGINE INSTALLATION (Contd)

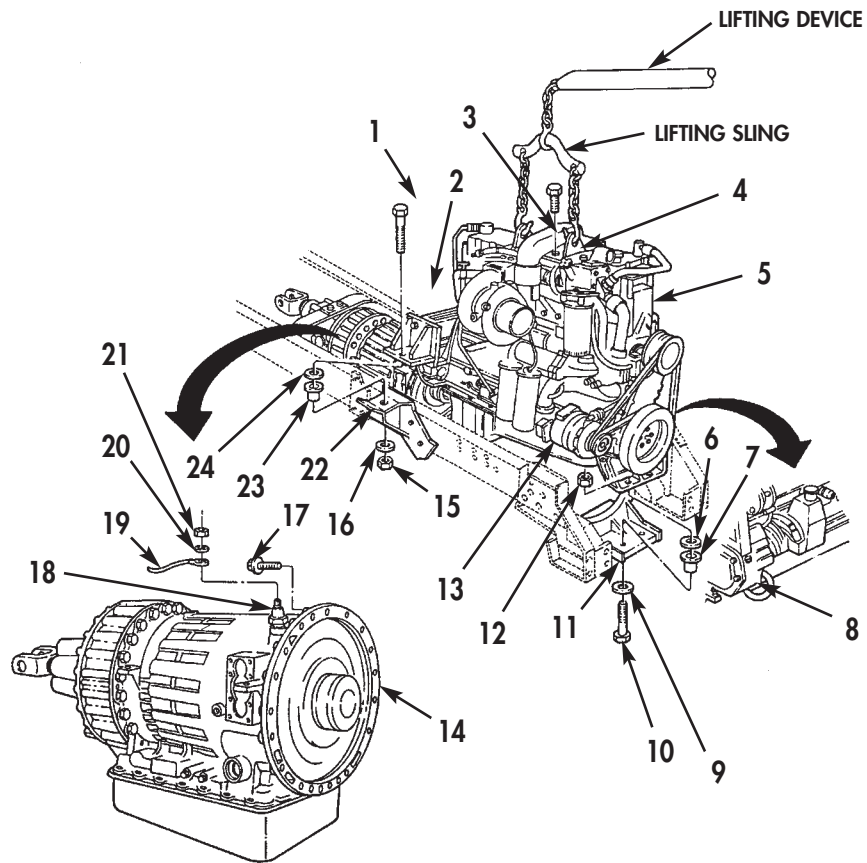


Figure 1. Engine Installation.

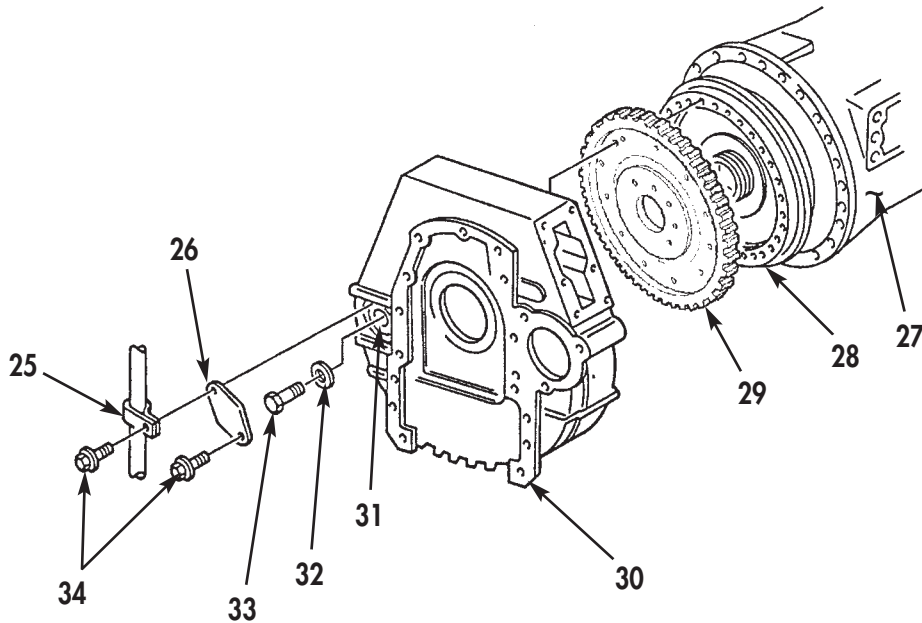


Figure 2. Ring Gear Installation.

BIG CAM I ENGINE INSTALLATION (Contd)

16. Install transmission floor shifter assembly (2) and floor pan access cover (1) to cab floor with ten floor pan access cover screws (4). Tighten screws (4) 15–20 lb-ft (20–27 N•m).
17. Position floor mat (3) around transmission floor shifter assembly (2) and floor pan access cover (1).
18. Install trunion (10) in transmission shift lever (8) with new trunion retaining pin (9).

NOTE

Refer to TM 2320-283-20-2 for shift control cable adjustment procedures.

19. Install transmission shift control cable assembly (14) to transmission shift control cable mounting bracket (13) with spacer plate (7), U-bolt (6), two new lockwashers (11), and new locknuts (12). Ensure grommet (5) is correctly positioned in U-bolt (6).
20. Install rear cooler hose bracket (17) to transmission (16) with rear cooler hose bracket washer (18) and screw (19).
21. Install middle cooler hose bracket (20) to oil pan (21) with middle cooler hose bracket screw (22).
22. Install front hose clamp (33) on cooler hose bracket (34) with front hose clamp screw (32) and nut (35).
23. Install positive battery cable (23), starter motor ground strap (28), and negative battery cable (25) on starter motor (24) with new starter motor terminal lockwasher (26) and nut (27).
24. Install ground strap (31) and starter motor ground strap (28) on engine (15) with new ground strap starwasher (29) and bolt (30).
25. Install transmission modulator control bracket (40) on engine (15) with two new transmission modulator control bracket lockwashers (41) and bolts (42).
26. Install transmission modulator control link (50) on transmission modulator control bracket (40) with U-bolt (43), spacer plate (44), two washers (45), and nuts (46).
27. Install transmission modulator control link (50) and washer (48) on fuel control lever (51) with new retaining pin (47).
28. Install accelerator link (49) on fuel control lever (51) accelerator link washer (37), return spring clip (38), and nut (36).
29. Install return spring (39) on transmission modulator control bracket (40) and spring clip (38).

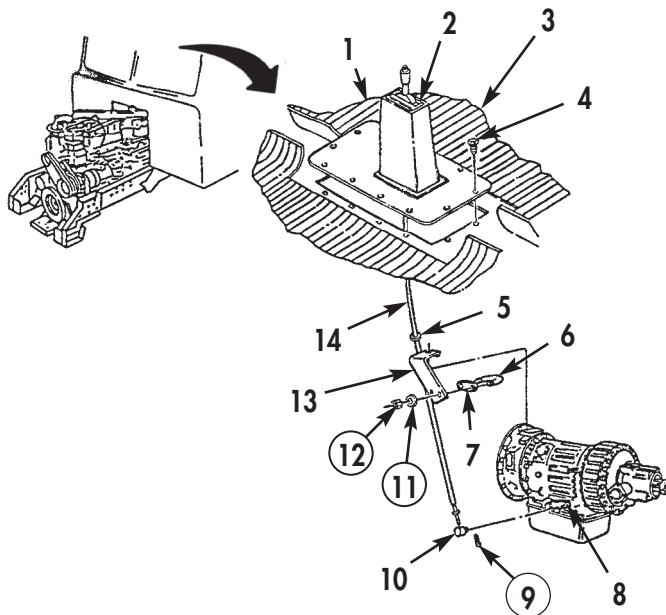


Figure 3. Transmission Shift Control Cable Installation.

BIG CAM I ENGINE INSTALLATION (Contd)

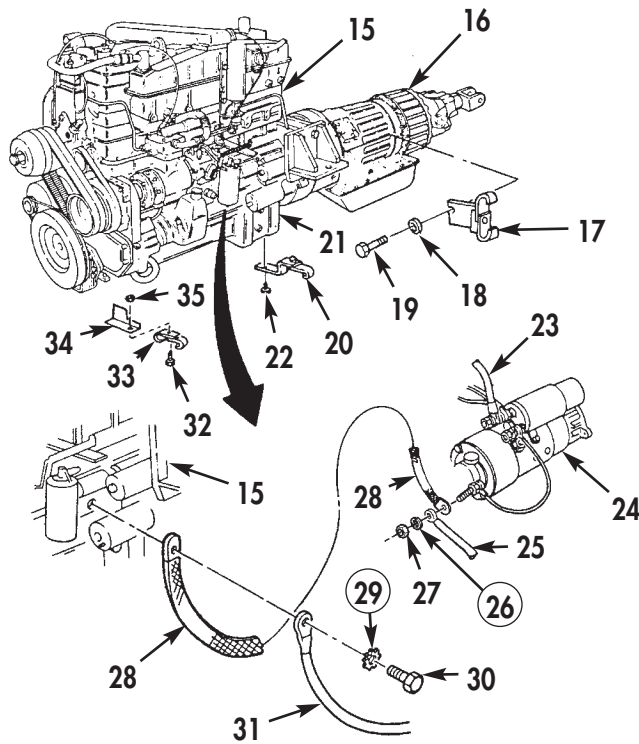


Figure 4. Starter Cable Installation.

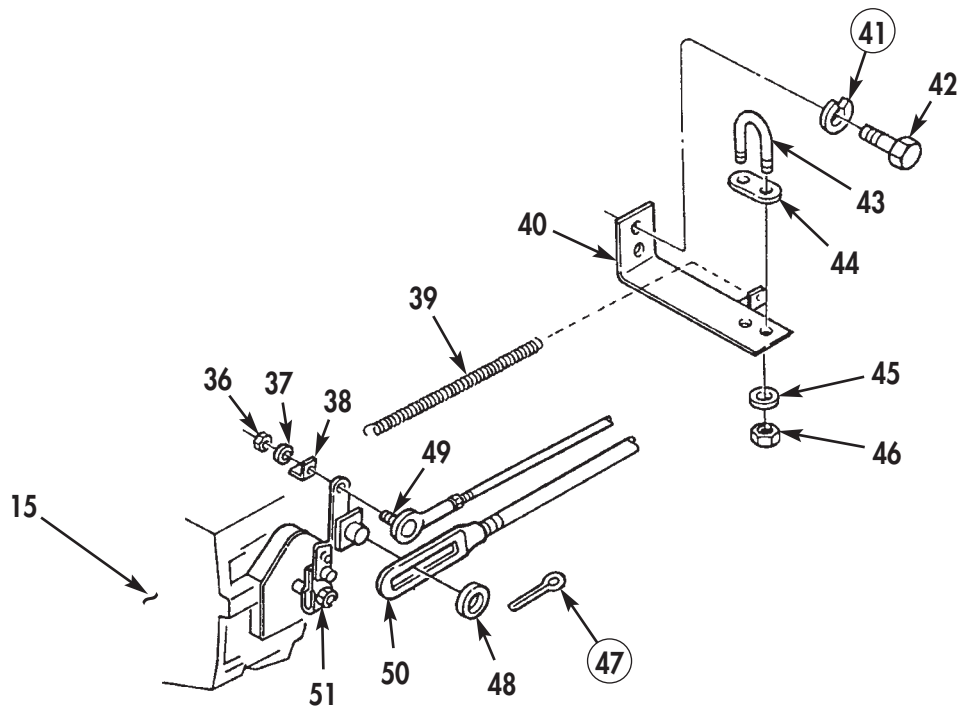


Figure 5. Accelerator Cable Installation.

BIG CAM I ENGINE INSTALLATION (Contd)

30. Connect engine harness electrical connectors (1) at firewall (2).
31. Install electrical harness bracket (4) on engine (5) with screw (3). Tighten screw (3) 15–20 lb-ft (20–27 N•m).
32. Connect air compressor line (6) to air compressor (7).
33. Connect fuel line (10) to fuel filter and damper (11).
34. Connect tachometer shaft assembly (15) to tachometer (14).
35. Install ether quick start kit bracket (8), on engine with two clamps (13) and (16) and bracket nut (17) and screw (12). Tighten nut (17) and screw (12) 15–20 lb-ft (20–27 N•m).
36. Install tachometer shaft assembly (15) on ether quick start kit bracket (8) with new plastic tie (9).
37. Install speedometer shaft assembly (22) on fuel return line (20) with new plastic tie (21).
38. Connect fuel return line (20) to fuel rail male branch tree (19).
39. Connect air compressor hose (23) to air compressor line (24).
40. Connect air compressor lines (24) and (25) to air compressor line T-adapter (18).

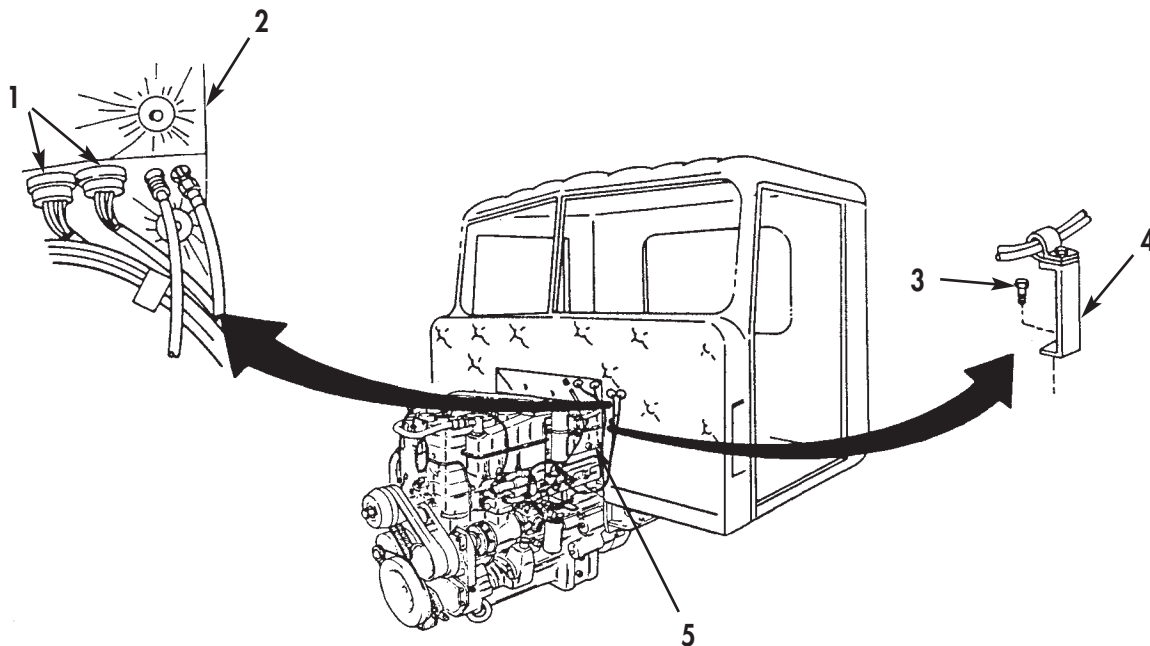


Figure 6. Electrical Engine Harness Installation.

BIG CAM I ENGINE INSTALLATION (Contd)

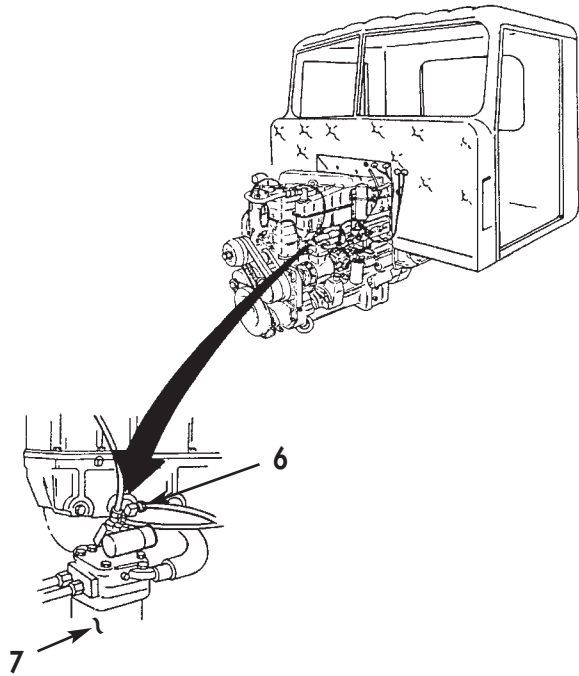


Figure 7. Air Compressor Installation.

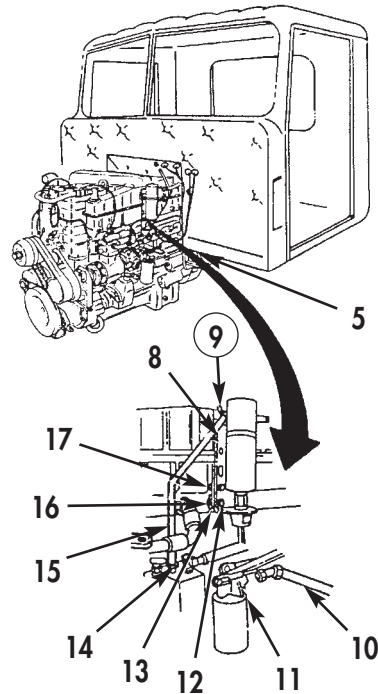


Figure 8. Fuel Filter and Lines Installation.

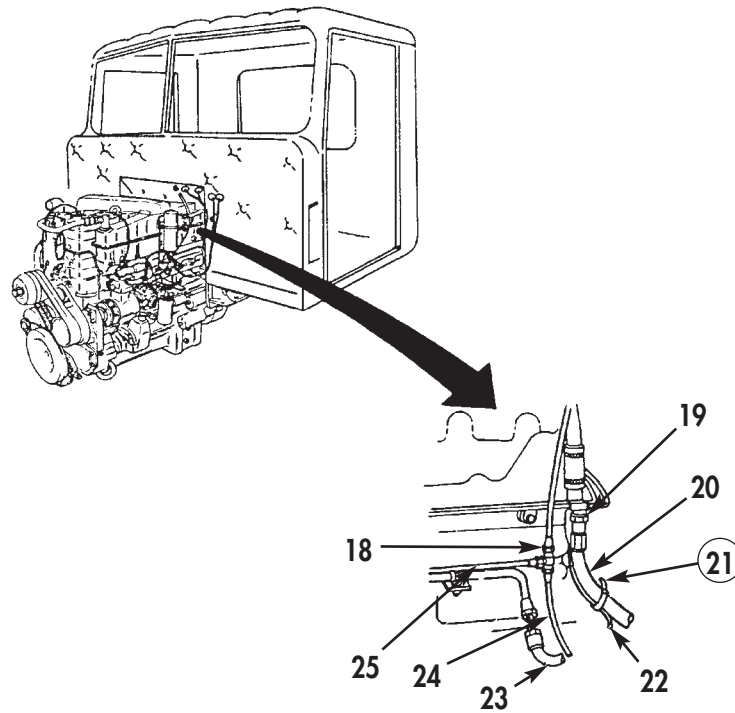


Figure 9. Fuel and Air Compressor Lines Connection.

BIG CAM I ENGINE INSTALLATION (Contd)

41. Position heater tube (11) and secure to fitting (13) using flare nut (12). Do not tighten flare nut (12).
42. Connect heater hose (4) to heater tube (11) and secure using clamp (6).
43. Connect heater hose (5) to heater tube (9) and secure using clamp (6).
44. Connect heater hose (15) to heater valve (14) and secure using clamp (6).
45. Secure heater hose (4), heater hose (5), bracket (8), bracket (10), and battery cable terminal (7) in three places using clamps (2) bolts (3) and nuts (1).
46. Tighten flare nut (12) to fitting (13).

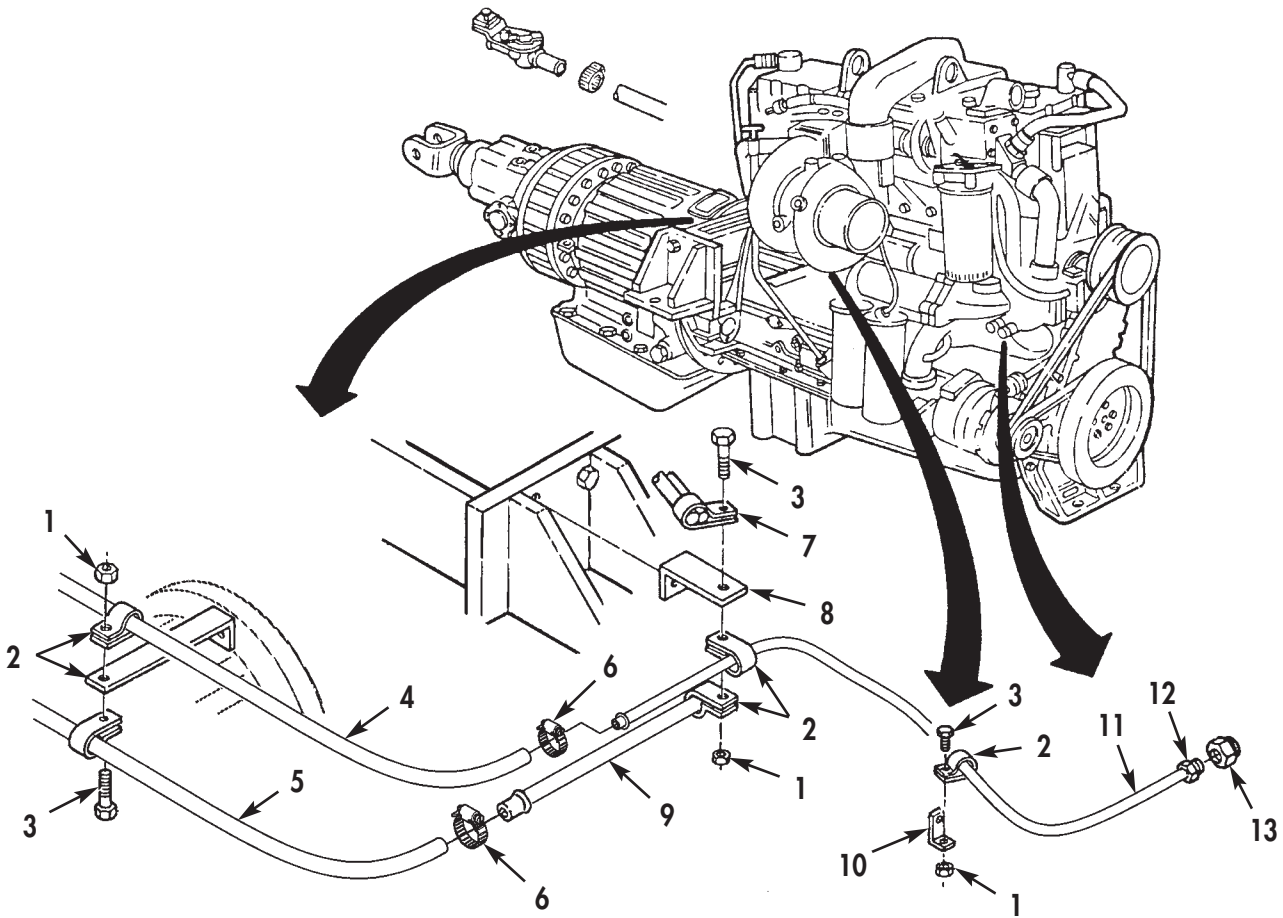


Figure 10. Heater Hose Installation.

BIG CAM I ENGINE INSTALLATION (Contd)

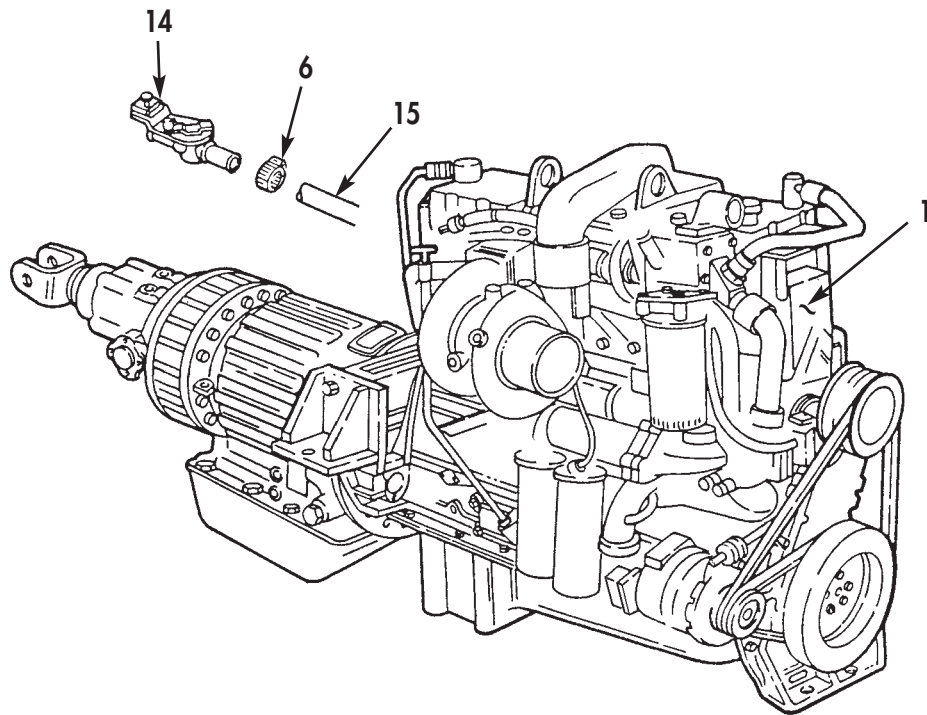


Figure 11. Heater Valve Installation.

BIG CAM I ENGINE INSTALLATION (Contd)

47. Loosen two lower alternator screws (1) retaining alternator (19) in position.
48. Install new alternator adjusting rod lockwasher (6), washer (5), alternator adjusting rod (9), alternator adjusting rod block (12), three alternator adjusting rod nuts (10) and two washers (11) as an assembly on engine (3) with alternator adjusting rod bolt (7).
49. Install alternator (19) to alternator adjusting rod block (12) with washer (13), nut (2), and alternator bolt (14). Do not tighten alternator bolt (14) at this time.
50. Install two new belts (8) on alternator pulley (15) and crankshaft pulley (4).
51. Using alternator adjusting rod nuts (10), adjust alternator (19) belt tension 110 lbs (50 kg).
52. Tighten two lower alternator nuts (17) and alternator adjusting rod nuts (10).
53. Install horn wire (TM 9-2320-283-20).
54. Install radiator and support rods (TM 9-2320-283-20).
55. Install grille shell (TM 9-2320-283-20).
56. Install fan (TM 9-2320-283-20).
57. Install upper radiator fan shroud (TM 9-2320-283-20).
58. Install radiator support brackets (TM 9-2320-283-20).
59. Install air cleaner (TM 9-2320-283-20).
60. Install turbocharger exhaust tube (TM 9-2320-283-20).
61. Install cooling system hoses (TM 9-2320-283-20).
62. Install power steering pump hydraulic lines (TM 9-2320-283-20).
63. Fill steering system to proper level (TM 9-2320-283-20).
64. Install transmission oil cooler lines (TM 9-2320-283-20).
65. Fill cooling system to proper level (TM 9-2320-283-20).
66. Fill engine crankcase to proper level (TM 9-2320-283-20).
67. Install hood (TM 9-2320-283-20).
68. Install fenders (TM 9-2320-283-20).
69. Install bumper and towing eyes (TM 9-2320-283-20).
70. Install brush guard and spotter mirrors (TM 9-2320-283-20).
71. Close air reservoir draincocks (TM 9-2320-283-20).
72. Install negative battery cable (20) on battery (23), and connect two negative battery cable clamps (21) on two negative battery cable posts (22).

CAUTION

Always perform break-in procedures for a new or repaired engine to prevent premature bearing and ring failure.

73. Perform engine testing (WP 0047 00).

BIG CAM I ENGINE INSTALLATION (Contd)

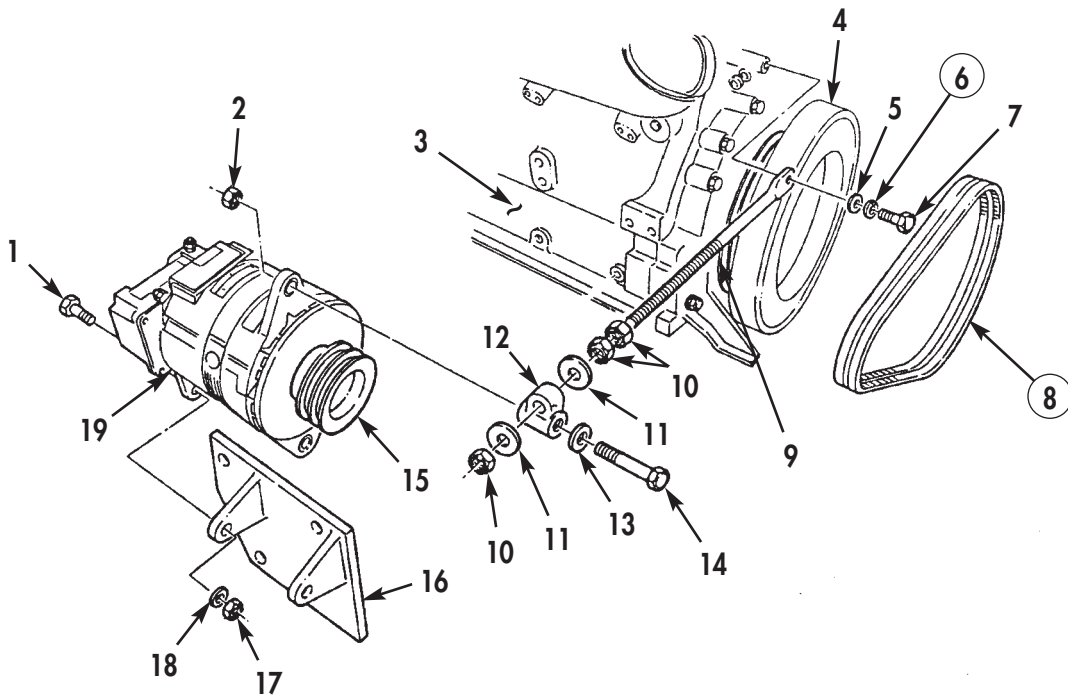


Figure 12. Alternator Belt Installation.

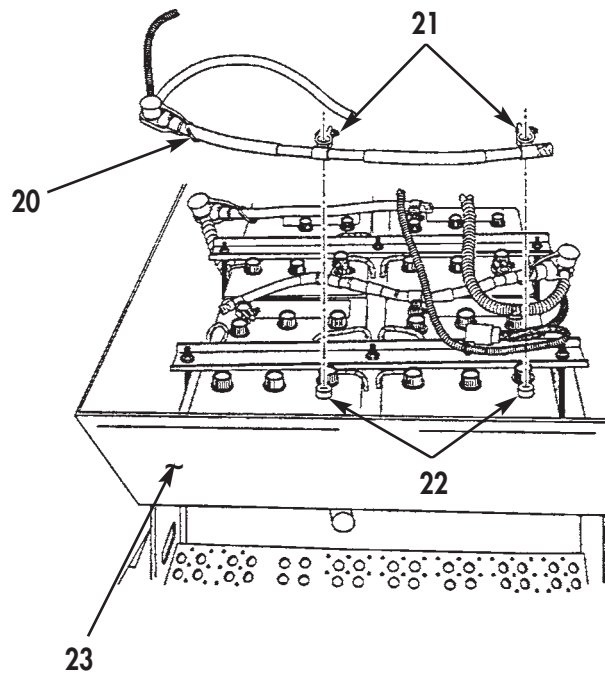


Figure 13. Battery Cables Installation.

**DIRECT SUPPORT AND GENERAL SUPPORT
MAINTENANCE MANUAL
INCLUDING REPAIR PARTS AND SPECIAL TOOLS LIST (RPSTL)
FOR
M915, M915A1, M915A4, M916, M920 VEHICLES**

NSN 2815-01-082-8125	P/N NTC400-3652-02	CUMMINS NTC-400 BIG CAM I DIESEL ENGINE W/CONTAINER
NSN 2815-01-142-2745	P/N 11669835	CUMMINS NTC-400 BIG CAM III DIESEL ENGINE W/CONTAINER

BIG CAM III MODIFICATION KIT INSTALLATION INSTRUCTIONS

INITIAL SETUP:

Tools and Special Tools

General mechanic's tool kit: automotive
(Item 1, WP 0061 00)
Maintenance and repair shop equipment,
automotive (Item 2, WP 0061 00)
Automotive maintenance and repair
supplemental set no. 2 (Item 3, WP 0061 00)

Personnel Required

Assistant

BIG CAM III MODIFICATION KIT INSTALLATION INSTRUCTIONS (Contd)

GENERAL INFORMATION

NOTE

The following guidelines apply for using the Big Cam III engines in other than M915A1 vehicles.

1. Installing the Big Cam III requires that you retain and use the following components from the BIG Cam I:
 - Big Cam I flywheel housing
 - Big Cam I flywheel
 - Big Cam I lower alternator bracket

NOTE

It is recommended that you retain the Big Cam I engine for use of other miscellaneous parts.

2. Refer to table 1 for parts which are required to complete the conversion.

Table 1. Parts Required for Big Cam III Conversion.

NAME	PART NUMBER	NATIONAL STOCK NUMBER	QUANTITY
Seal ring	2D6507	5330-01-066-4537	1
Seal	5P3881	5330-01-079-4737	1
Pipe plug	144027	4730-00-014-4027	2
Pipe plug	444632	4730-00-044-4632	1
Plug button	142083	5340-00-290-4532	1

BIG CAM III MODIFICATION KIT INSTALLATION INSTRUCTIONS (Contd)

ENGINE PREPARATION

NOTE

All material removed and not reused during installation will be returned to stock for disposition in accordance with AR 725-50.

1. Remove alternator, alternator drive belt, and alternator mounting bracket from Big Cam III engine (2). Refer to WP 0008.
2. Install Big Cam I alternator mounting bracket (3) on Big Cam III engine (2) with three bolts (1). Tighten bolts (1).
3. Install Big Cam I alternator and drive belt on Big Cam III engine. Refer to WP 0049.
4. Remove existing Big Cam I engine from vehicle. Refer to WP 0007.

BIG CAM III INSTALLATION PROCEDURES

1. Drain oil from Big Cam III bypass filter (4) and remove oil bypass filter element from bypass filter (4).
2. Remove two elbows (5) from oil bypass filter (4).
3. Install two plugs (6) on Big Cam III oil bypass filter (4).

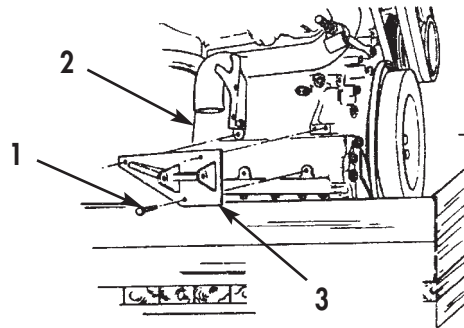


Figure 1. Big Cam I Alternator Bracket Installation on Big Cam III Engine.

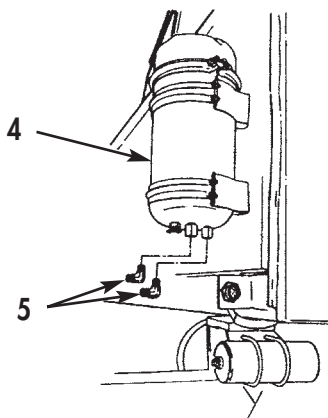


Figure 2. Oil Bypass Filter (Big Cam III).

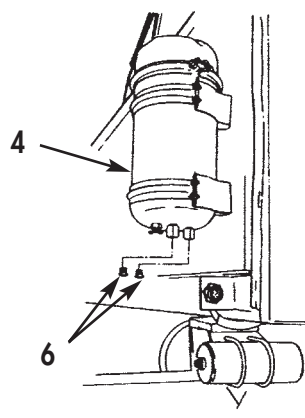


Figure 3. Oil Bypass Plug Installation (Big Cam III).

BIG CAM III MODIFICATION KIT INSTALLATION INSTRUCTIONS (Contd)

BIG CAM III INSTALLATION PROCEDURES (Contd)

4. Install two flywheel housing guide pins on Big Cam III engine (1).
5. Install Big Cam I flywheel housing (2) on Big Cam III engine (1) with seven of nine screws (6) and washers (7). Tighten screws (6) 10–20 lb-ft (14–27 N•m).
6. Remove two flywheel housing guide pins from Big Cam III engine (1) and install two remaining screws (6) and washers (7) on Big Cam I flywheel housing (2). Tighten screws (6) 10–20 lb-ft (14–27 N•m).
7. Install two 5/8–18x6 in. guide studs in opposite holes on Big Cam III crankshaft (8) until fully seated.
8. Apply lubricating oil to threads of screws (4) and face of washers (3). Allow excess oil to drain from screw threads.
9. Install Big Cam I flywheel (5) on Big Cam III crankshaft (8) with four screws (4) and washers (3). Tighten screws (4) hand-tight in sequence shown in figure 4.
10. Remove two guide studs and install two remaining screws (4) and washers (3) on Big Cam I flywheel (5). Tighten screws (4) 70 lb-ft (95 N•m) then 140 lb-ft (190 N•m) and finally 200–220 lb-ft (271–298 N•m) in sequence shown in figure 4.

NOTE

The flywheel must be pushed toward front of engine to remove crankshaft end clearance when crankshaft is rotated and measurements are taken. If total indicator readings exceed limits, remove flywheel; clean flywheel and crankshaft flange faces, install, and repeat runout checks.

11. Install dial gauge attachment and dial indicator on Big Cam I flywheel housing (2).
12. Position contact tip of dial indicator against wide diameter of Big Cam I flywheel (5) bore and set dial indicator to zero. Rotate crankshaft (8) one complete revolution. Total indicator reading must not exceed 0.005 in. (0.127 mm).
13. Inspect Big Cam I flywheel (5) face runout and install or reposition dial indicator on Big Cam I flywheel housing (2).
14. Position contact tip of dial indicator against face of Big Cam I flywheel (5) as close to outside diameter as possible. Rotate crankshaft (8) one complete revolution. Total indicator reading must not exceed 0.005 in. (0.127 mm).
15. Install Big Cam III engine in vehicle. Refer to WP 0048.

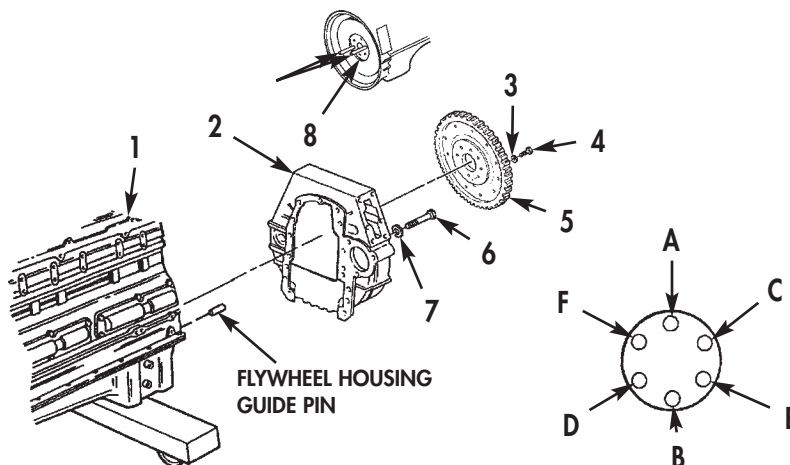


Figure 4. Big Cam I Flywheel Housing and Flywheel Installation.

BIG CAM III MODIFICATION KIT INSTALLATION INSTRUCTIONS (Contd)

BIG CAM III INSTALLATION PROCEDURES (Contd)

16. Install button plug (10) on air cleaner intake port (9).

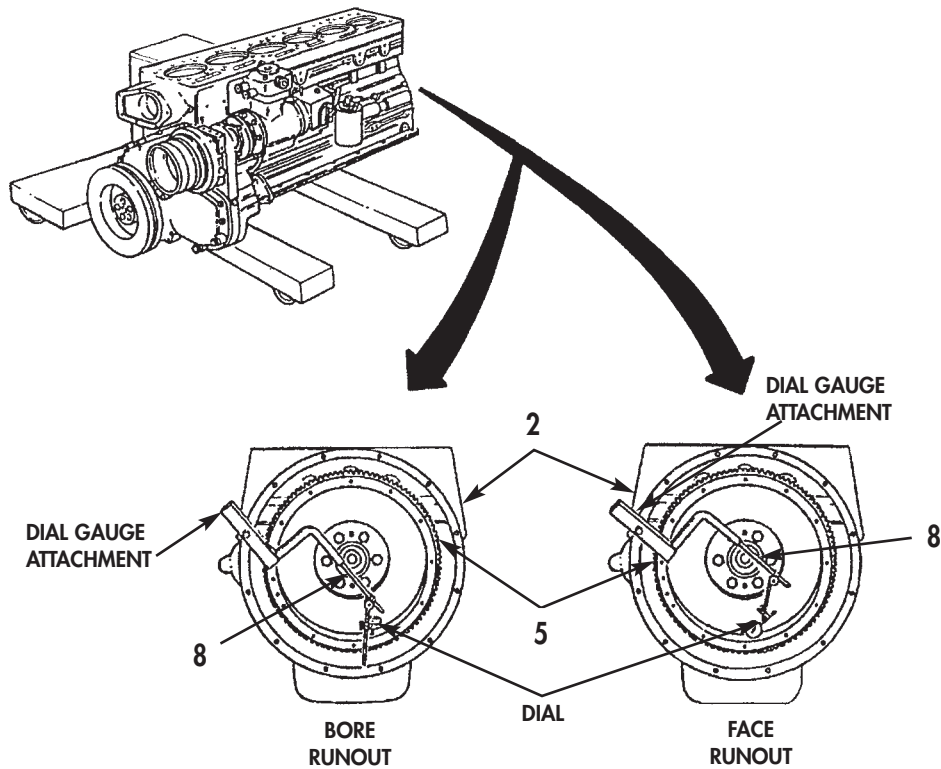


Figure 5. Measuring Runout.

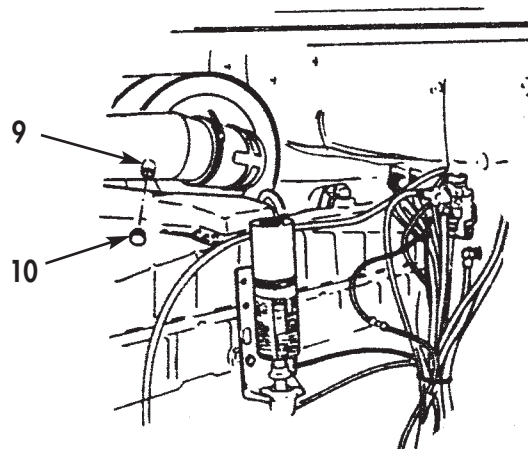


Figure 6. Air Cleaner Plug Installation.

**DIRECT SUPPORT AND GENERAL SUPPORT
MAINTENANCE MANUAL
INCLUDING REPAIR PARTS AND SPECIAL TOOLS LIST (RPSTL)
FOR
M915, M915A1, M915A4, M916, M920 VEHICLES**

NSN 2815-01-082-8125	P/N NTC400-3652-02	CUMMINS NTC-400 BIG CAM I DIESEL ENGINE W/CONTAINER
NSN 2815-01-142-2745	P/N 11669835	CUMMINS NTC-400 BIG CAM III DIESEL ENGINE W/CONTAINER

GENERAL MAINTENANCE INSTRUCTIONS

THIS WORK PACKAGE (WP) COVERS:

Scope; Precautions; Special Processes; Tools and Equipment; Disassembly; Cleaning; Inspection—Acceptance and Rejection Criteria; Repair or Replacement; and Assembly.

SCOPE

This WP contains general maintenance instructions pertaining to disassembly, cleaning, inspection, repair, and assembly of the Cummins NTC-400 diesel engine. Detailed information will be found in specific WPs. The repair procedures in this manual are for use at direct support and general support maintenance levels. All information contained in this manual applies to both Big Cam I and Big Cam III engines except where differences are specifically noted.

GENERAL MAINTENANCE INSTRUCTIONS (Contd)

PRECAUTIONS

All material-handling equipment shall be adequate to ensure safe working conditions for personnel and efficient processing of items.

The component shall be properly mounted on a fixture for disassembly and assembly to ensure safe working conditions.

Follow all WARNINGS, CAUTIONS, and NOTES included in specific WPs to ensure personnel safety and prevent damage to equipment.

SPECIAL PROCESSES

Special processes and equipment required for maintenance operations, as specified in this manual, are defined or referenced at the point of their application. When a special process is required, the maintenance activity (when requested) shall provide evidence of compliance with controlling specifications. Following is a summary of some of the special processes that may be required for this manual.

Table 1. Special Processes.

SPECIAL PROCESS	DESCRIPTION
Liquid Penetrant Inspection	E 1417, Standard Practice for Liquid Penetrant Examination, is followed when using fluorescent or visible dye to detect cracks, flaws, etc., open to the surface of any nonporous metal.
Magnetic Particle Inspection	E 1444, Standard Practice for Magnetic Particle Examination, is used to detect cracks, etc., at or below surface of ferrous (ferromagnetic) metals.

TOOLS AND EQUIPMENT

Tools and equipment required to overhaul this component can be found in Tools and Special Tools, WP 0061 00.

Torque wrench specifications are given in text, as applicable. Metric equivalents are in parentheses following the U.S. standard measurement. (Example: Tighten oil pump mounting bolts 33–40 lb-ft (45–54 N·m).) Standard capscrew markings and torque specifications are found in Torque Limits, WP 0053 00. Tolerances, torque values, and adjustments are provided in each WP as necessary.

GENERAL MAINTENANCE INSTRUCTIONS (Contd)

DISASSEMBLY

Each appropriate WP will contain specific instructions for disassembly of the components.

Take care in handling parts during disassembly. Nicks, scratches, or other damage caused by careless handling may cause premature failure of equipment.

Matched, married, or mated items (examples: bearings and races, covers and housings, and some gear sets) should be fastened together or otherwise identified as parts being processed together. If one part fails inspection, both parts must be replaced as a set.

CLEANING

CAUTION

Block all ports and mask machined surfaces of aluminum castings before using the following cleaning procedures. Failure to comply may result in damage to equipment.

Do not separate or intermix matched, married, or mated parts during cleaning operations. Refer to Disassembly above.

For authorized cleaning materials, refer to TM 9-247, Materials Used for Cleaning, Preserving, Abrading, and Cementing.

Remove all rust and surface scale using a wire brush, sand blast, grit blast, or other effective methods in accordance with standard procedures.

GENERAL MAINTENANCE INSTRUCTIONS (Contd)

INSPECTION—ACCEPTANCE AND REJECTION CRITERIA

NOTE

All components subjected to magnetic particle inspection shall be demagnetized prior to assembly.

All components subjected to dye penetrant inspection shall be cleaned after inspection. Coat part with preservative oil as required.

Throughout this manual, measurements are used to confirm serviceability of items after a visual inspection. Measurements will be performed as required by quality assurance, in-process inspection, maintenance procedures, engine test report, and Final Inspection Report (FIR).

Used components and refinished parts, recovered as products of disassembly, will be examined 100 percent to determine serviceability by contractor. Refer to the maintenance WPs, work directive, or contract for more detail.

Parts showing evidence of overheating are unrepairable by any process. Discard these parts.

WARNING

Compressed air source must not exceed 30 psi (207 kPa). Wear eyeshields when cleaning with compressed air. Failure to comply may result in injury to personnel.

NOTE

Some parts may not look exactly like illustrations. Manufacturing methods may change part appearance, but parts are functionally the same.

Table 2. General Inspection Guidelines.

INSPECT	ACTION
Oil passages	Remove all obstructions with compressed air or by working a soft wire back and forth through oil passage.
Threads (internal and external)	Inspect threads for minor irregularities. For damaged thread repair, refer to table 3, Repairable Defects.
Machined surfaces	Check for damage that could cause oil leakage or malfunction of the part. Refer to table 3, Repairable Defects.
Gear	Check for nicks, burrs, or scoring. If any such conditions are found, refer to table 3, Repairable Defects.

GENERAL MAINTENANCE INSTRUCTIONS (Contd)

REPAIR OR REPLACEMENT

Parts that are beyond wear limit tolerances, broken, cracked, or otherwise damaged may be considered for repair by special processes listed below by requesting approval from TACOM. In requesting approval, the maintenance activity will furnish:

1. Written repair procedure
2. Specifications covering the procedure
3. Reference drawing

Unrepairable Defects

Do not repair any of the following:

1. Casting cracks at through-bores, threaded holes, or high-stress areas
2. Cracked, chipped, ridged, or pitted gear teeth
3. Cracked or split keyways
4. Scored or scratched bores
5. Cracked or chipped snapping grooves
6. Oil channels with cracked walls or chipped edges
7. Pitted or grooved gear teeth, unless otherwise indicated in this manual
8. Parts showing evidence of overheating
9. Chipped edges, burred sealing ridges, and longitudinal scratches on sealing surfaces

GENERAL MAINTENANCE INSTRUCTIONS (Contd)**Repairable Defects***Table 3. Repairable Defects.*

REPAIRABLE PART/AREA	REPAIR PROCESS
Machined surfaces	Small burrs and scratches may be removed with a fine mill file or fine grit emery cloth. Discard components that have burrs or scratches too large to repair. Cylinder block and cylinder head can be resurfaced to correct surface defects and warpage.
Damaged external threads	Repair threads having slight irregularities. Remove burrs with a soft stone, fine mill file, or emery cloth. Clean up slight irregularities by running thread die of correct size over thread. Discard components not repairable.
Damaged internal threads	Repair threads in tapped holes having minor irregularities by retapping with correct size previously used hole tap. Drill-out tapped holes having badly damaged threads and install a threaded insert. Follow kit manufacturer's and NASM33537 instructions. When drilling, the land width (space between holes, or between edge of hole and edge of material) must measure no less than three-fourths of the hole diameter. Discard components not repairable.
Housing; castings; and shaped, machined surfaces	Unless otherwise indicated, use fine emery cloth, crocus cloth, or soft stone to repair minor nicks, burrs, and scoring. Minor surface irregularities on noncontact surfaces do not need repair. Discard components not repairable.
Gears, splines, and shafts	Use crocus cloth, fine mill file, or soft stone to remove minor nicks, burrs, and scoring. Welding, grinding, machining, plating, etc. of gears to correct defects is not authorized. Discard components not repairable.
Surface rust and corrosion	Remove surface rust and corrosion from all internal parts and surfaces. Mechanical and/or chemical methods may be used. Use fine emery cloth, crocus cloth, or soft stone to remove minor surface rust and corrosion. Do not assemble components having rusted or corroded parts. Corrosion or rust may flake off and cause damage to component while circulating in oil during operation. Discard components not repairable.

GENERAL MAINTENANCE INSTRUCTIONS (Contd)

ASSEMBLY

Cleanliness is essential in all component assembly operations. Dust and dirt, even in minute quantities, are abrasive. Parts must be kept clean. See individual WPs for specific assembly instructions.

Replace any part that does not pass visual inspection or that is outside specified wear limits listed in the maintenance WPs.

Follow WP instructions for coating bearings, bushings, gears, shafts, seals, friction parts, and other contact surfaces with operating oil (engine oil for engine parts, etc.) to ensure lubrication of parts during initial operation after repair.

Seal handling:

1. Do not open seal packets until ready to install seal. Seals may become contaminated with dust or dirt. Some types of seals can absorb moisture, which may cause damage during installation and/or shorten the lifespan of the seals.
2. Ensure lip-type seals are installed so spring-loaded lip faces toward lubricant. Tighten all capscrews, screws, bolts, nuts, and fittings to torque values specified in maintenance WPs and in WP 0053 00.

For parts identification, refer to WP 0058 00.

**DIRECT SUPPORT AND GENERAL SUPPORT
MAINTENANCE MANUAL
INCLUDING REPAIR PARTS AND SPECIAL TOOLS LIST (RPSTL)**

FOR

M915, M915A1, M915A4, M916, M920 VEHICLES

NSN 2815-01-082-8125	P/N NTC400-3652-02	CUMMINS NTC-400 BIG CAM I DIESEL ENGINE W/CONTAINER
NSN 2815-01-142-2745	P/N 11669835	CUMMINS NTC-400 BIG CAM III DIESEL ENGINE W/CONTAINER

ILLUSTRATED LIST OF MANUFACTURED ITEMS

SCOPE

This Work Package (WP) includes complete instructions for making items authorized to be manufactured or fabricated.

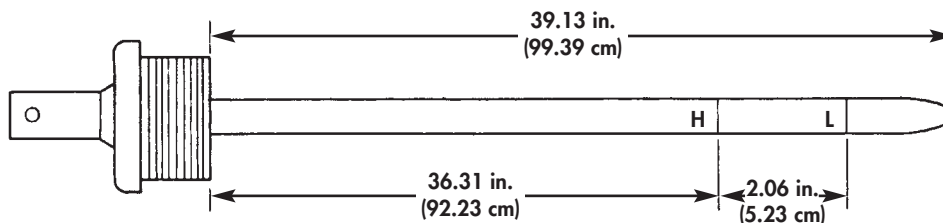
EXPLANATION OF THE ILLUSTRATIONS OF MANUFACTURED ITEMS

All instructions needed by maintenance personnel to manufacture the item are included on the illustrations. All bulk materials needed for manufacture of an item are listed by part number or national stock number in a tabular list on the illustration.

Table 1. Manufactured Items Part Number Table of Contents.

ITEM NO.	NSN	PART NO.	ITEM	PAGE NO.
1.	6680-01-108-7410	199453	Oil level dipstick	0052 00-2
2.	5305-00-795-9336	204165	Flywheel housing guide pin (two required)	0052 00-3
3.	5305-01-145-8380	S-189-B	Vibration damper guide pin (two required)	0052 00-4

ILLUSTRATED LIST OF MANUFACTURED ITEMS (Contd)

**PROCEDURE:**

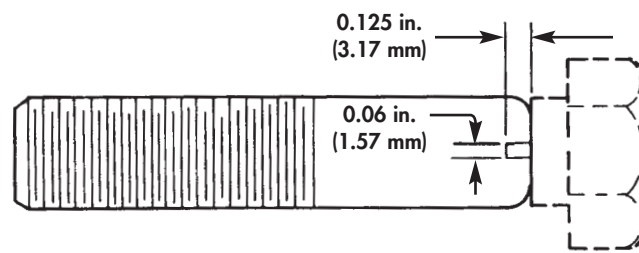
1. Using roller, measure 39.13 in. (99.39 cm) down dipstick from bottom of rubber stopper and cut dipstick. Round off tip of dipstick.

NOTE

Use an electric engraver to perform etching in steps 2, 3, and 4. Etch dipstick to a depth of 0.005–0.010 in. (0.127–0.254 mm).

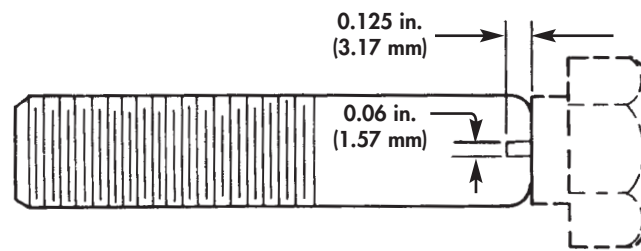
2. Measure 36.31 in. (92.23 cm) down dipstick from bottom of rubber stopper and etch a line on dipstick at this length. Etch an “H” next to this line.
3. Measure 2.06 in. (5.23 cm) down dipstick from line etched in step 3 and etch another line at this length. Etch an “L” next to this line.
4. Etch part number 199453 on dipstick near rubber stopper.

ITEM 1. OIL LEVEL DIPSTICK

ILLUSTRATED LIST OF MANUFACTURED ITEMS (Contd)**PROCEDURE:**

1. Using hack saw, cut off head of screw.
2. Round off edge of non-threaded end of screw.
3. Using press, cut a slit approximately 0.06 in. (1.57 mm) wide and 0.125 in. (3.17 mm) deep in non-threaded end of screw.
4. Using grinding wheel, remove any burrs after cutting.

ITEM 2. FLYWHEEL HOUSING GUIDE PIN

ILLUSTRATED LIST OF MANUFACTURED ITEMS (Contd)**PROCEDURE:**

1. Using hack saw, cut off head of screw.
2. Round off edge of non-threaded end of screw.
3. Using press, cut a slit approximately 0.06 in. (1.57 mm) wide and 0.125 in. (3.17 mm) deep in non-threaded end of screw.
4. Using grinding wheel, remove any burrs after cutting.

ITEM 3. VIBRATION DAMPER GUIDE PIN

**DIRECT SUPPORT AND GENERAL SUPPORT
MAINTENANCE MANUAL
INCLUDING REPAIR PARTS AND SPECIAL TOOLS LIST (RPSTL)
FOR
M915, M915A1, M915A4, M916, M920 VEHICLES**

NSN 2815-01-082-8125	P/N NTC400-3652-02	CUMMINS NTC-400 BIG CAM I DIESEL ENGINE W/CONTAINER
NSN 2815-01-142-2745	P/N 11669835	CUMMINS NTC-400 BIG CAM III DIESEL ENGINE W/CONTAINER

TORQUE LIMITS

SCOPE

CAUTION

General torque specifications cannot be applied to screws or fasteners that retain rubber components. The rubber components will be damaged before the correct torque limit can be reached. If a special torque limit is not given in the maintenance instructions for use with a rubber component, tighten the screw or nut until it touches the component, then tighten it one more turn.

This Work Package (WP) provides general torque limits for screws and fasteners used in this manual. Special torque limits are indicated in the maintenance procedures for applicable components and in table 4, Torque Specifications. The general torque limits given in this WP shall be used when specific torque limits are not indicated in the maintenance procedure.

TORQUE LIMITS (Contd)

TORQUE TABLES

Table 1 lists dry torque limits. Dry torque limits are used on screws that do not have lubricants applied to the threads. Table 2 lists wet torque limits. Wet torque limits are used on screws that have high-pressure lubricants applied to the threads. For metric fasteners, refer to table 3 for torque limit requirements.

HOW TO USE TORQUE TABLES

1. Measure the diameter of the screw you are installing.

NOTE

Perform step 2 for standard screws only. To determine if screw is standard or metric, check capscrew head and refer to the following illustration.

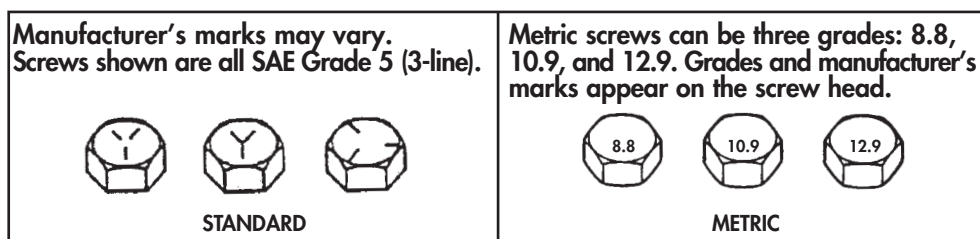


Figure 1. Capscrew Head Markings.

2. Count the number of threads per inch.

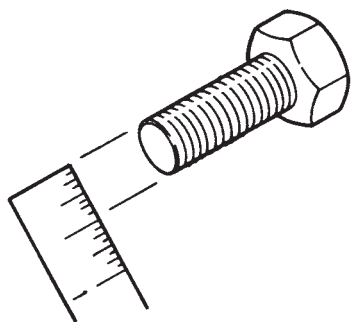


Figure 2. Measuring Screw Diameter.

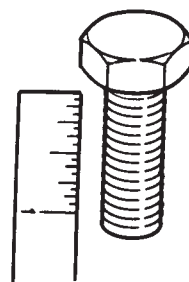


Figure 3. Counting Threads per Inch.

3. Refer to the appropriate Torque Limits table. Under the heading SIZE, look down the left-hand column until you find the diameter of the screw you are installing. (There usually will be two entries beginning with the same size.)

NOTE

Perform step 4 for standard screws only.

4. In the second column under SIZE, find the number of threads per inch that matches the number of threads you counted in step 2.
5. To find the grade screw you are installing, match the markings on the head to the correct picture in CAPSCREW HEAD MARKINGS preceding the torque tables.
6. Look down the column under the picture you found in step 5. until you find the torque limit (lb-ft or N•m) for the diameter and threads per inch of the screw.

TORQUE LIMITS (Contd)

Table 1. Torque Limits for Dry Fasteners.

SIZE			TORQUE							
			SAE GRADE NO. 1 or 2		SAE GRADE NO. 5		SAE GRADE NO. 6 or 7		SAE GRADE NO. 8	
DIA. INCHES	THREADS PER INCH	DIA. MILLIMETERS	POUND FEET	NEWTON METERS	POUND FEET	NEWTON METERS	POUND FEET	NEWTON METERS	POUND FEET	NEWTON METERS
1/4	20	6.35	5	7	8	11	10	14	12	16
1/4	28	6.35	6	9	10	14	12	16	14	19
5/16	18	7.94	11	15	17	23	21	28	24	33
5/16	24	7.94	12	16	19	26	24	33	27	37
3/8	16	9.53	20	27	30	41	40	54	45	61
3/8	24	9.53	23	31	35	47	45	61	50	68
7/16	14	11.11	30	41	50	68	60	81	70	95
7/16	20		35	47	55	75	70	95	80	108
1/2	13	12.70	50	68	75	102	95	129	110	149
1/2	20		55	75	90	122	100	136	120	163
9/16	12	14.29	65	88	110	149	135	183	150	203
9/16	18		75	102	120	163	150	203	170	231
5/8	11	15.88	90	122	150	203	190	258	220	298
5/8	18		100	136	180	244	210	285	240	325
3/4	10	19.05	160	217	260	353	320	434	380	515
3/4	16		180	244	300	407	360	488	420	597
7/8	9	22.23	140	190	400	542	520	705	600	814
7/8	14		155	210	440	597	580	786	660	895
1	8	25.40	220	298	580	786	800	1085	900	1220
1	12		240	325	640	868	860	1166	1000	1356
1 1/8	7	25.58	300	407	800	1085	1120	1519	1280	1736
1 1/8	12		340	461	880	1193	1260	1709	1440	1953
1 1/4	7	31.75	420	570	1120	1519	1580	2142	1820	2468
1 1/4	12		460	624	1240	1681	1760	2387	2000	2712
1 3/8	6	34.93	560	759	1460	1980	2080	2820	2380	3227
1 3/8	12		640	868	1690	2278	2380	3227	2720	3688
1 1/2	6	38.10	740	1003	1940	2631	2780	3770	3160	4285
1 1/2	12		840	1139	2200	2983	3100	4204	3560	4827

TORQUE LIMITS (Contd)

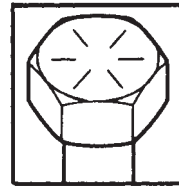
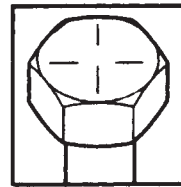
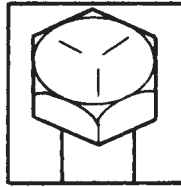
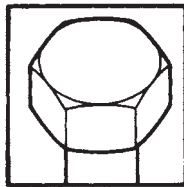
Table 2. Torque Limits for Wet Fasteners.

SIZE			TORQUE							
			SAE GRADE NO. 1 or 2		SAE GRADE NO. 5		SAE GRADE NO. 6 or 7		SAE GRADE NO. 8	
DIA. INCHES	THREADS PER INCH	DIA. MILLIMETERS	POUND FEET	NEWTON METERS	POUND FEET	NEWTON METERS	POUND FEET	NEWTON METERS	POUND FEET	NEWTON METERS
1/4	20	6.35	4	6	6	8	8	11	9	12
1/4	28	6.35	5	7	7	9	9	12	10	14
5/16	18	7.94	8	11	13	18	16	22	18	24
5/16	24	7.94	9	12	14	19	18	24	20	27
3/8	16	9.53	15	20	23	31	30	41	40	54
3/8	24	9.53	17	23	25	34	30	41	44	60
7/16	14	11.11	24	33	35	47	45	61	55	75
7/16	20		25	34	40	54	50	68	60	81
1/2	13	12.70	35	47	55	75	70	95	80	108
1/2	20		40	54	65	88	80	108	90	122
9/16	12	14.29	50	68	80	108	100	136	110	149
9/16	18		55	75	90	122	110	149	130	176
5/8	11	15.88	70	95	110	149	140	190	170	231
5/8	18		80	108	130	176	160	217	180	244
3/4	10	19.05	120	163	200	271	240	325	280	380
3/4	16		140	190	220	298	280	380	320	434
7/8	9	22.23	110	149	300	407	400	542	460	624
7/8	14		120	163	320	434	440	597	500	678
1	8	25.40	160	217	440	597	600	814	680	922
1	12		170	231	480	651	660	895	740	1003
1 1/8	7	25.58	220	298	600	814	840	1139	960	1302
1 1/8	12		260	353	660	895	940	1275	1080	1464
1 1/4	7	31.75	320	434	840	1139	1100	1492	1360	1844
1 1/4	12		360	488	920	1248	1320	1790	1500	2034
1 3/8	6	34.93	420	570	1100	1492	1560	2115	1780	2414
1 3/8	12		460	624	1260	1709	1780	2414	2040	2766
1 1/2	6	38.10	560	760	1460	1980	2080	2820	2360	3200
1 1/2	12		620	841	1640	2224	2320	3146	2660	3607

CAPSCREW HEAD MARKINGS



Manufacturer's marks may vary. Screws shown above are all SAE Grade 5 (3-line).



TORQUE LIMITS (Contd)

Table 3. Torque Limits for Metric Fasteners.

CAPSCREW HEAD MARKINGS		TORQUE					
		METRIC GRADE 8.8		METRIC GRADE 10.9		METRIC GRADE 12.9	
DIA. INCHES	DIA. MILLIMETERS	POUND FEET	NEWTON METERS	POUND FEET	NEWTON METERS	POUND FEET	NEWTON METERS
.157	4	2	3	3	4	4	5
.197	5	4	5	6	8	7	9
.237	6	7	9	10	14	11	15
.276	7	11	15	16	22	20	27
.315	8	18	24	25	34	29	39
.394	10	32	43	47	64	58	79
.473	12	58	79	83	113	100	136
.552	14	94	127	133	180	159	216
.630	16	144	195	196	266	235	319
.709	18	190	258	269	365	323	438
.788	20	260	353	366	496	440	597
.867	22	368	499	520	705	678	919
.946	24	470	637	664	900	794	1077
1.064	27	707	959	996	1351	1235	1675
1.182	30	967	1311	1357	1840	1630	2210

TORQUE LIMITS (Contd)

TORQUE WRENCH ADAPTERS

Some tasks require the use of a torque wrench adapter when the nut or screw cannot be reached with a regular socket on the end of the torque wrench. These adapters add to the overall length of the torque wrench and make the dial or scale reading less than the actual torque applied to the nut or screw. To prevent overtightening and damage to equipment, calculate correct dial or scale reading using the following conversion formula.

CONVERSION FORMULA

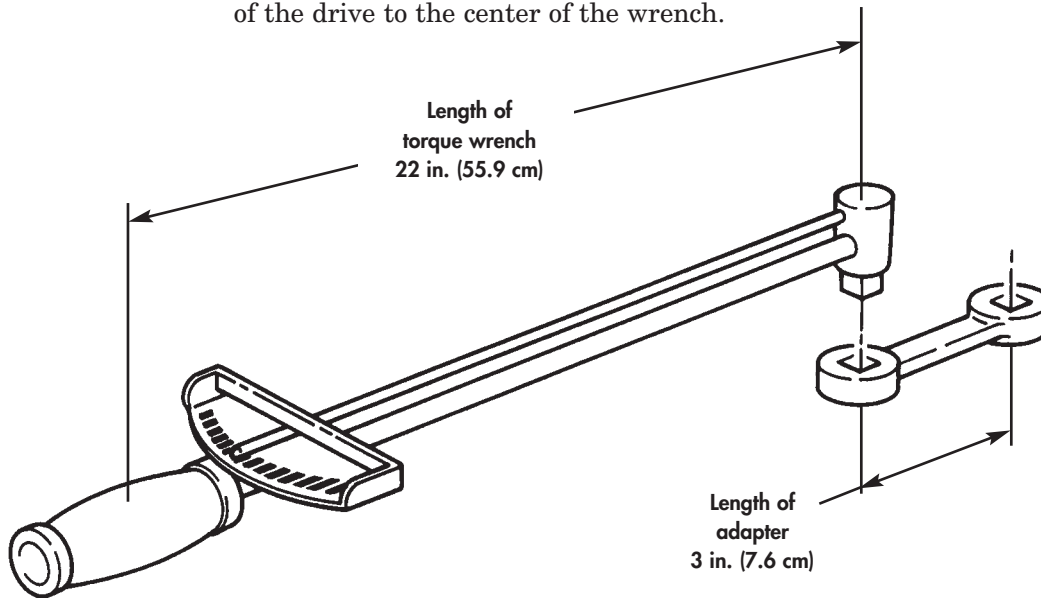
Corrected dial or scale readings are determined by the use of the following formula:

$$\text{Corrected reading} = \text{Required torque value} \div \frac{\text{Length of torque wrench} + \text{Length of adapter}}{\text{Length of torque wrench}}$$

NOTE

The length of the torque wrench is measured from the center of the handle to the center of the drive. The length of the adapter is measured from the center of the drive to the center of the wrench.

Example:



In this example, the torque wrench measures 22 in. (55.9 cm) and the adapter is 3 in. (7.6 cm). The required torque is 19 lb-ft (25.8 N•m).

$$\begin{aligned} \text{Corrected reading} &= 19 \text{ lb-ft (25.8 N}\cdot\text{m)} \div \frac{22 \text{ in. (55.9 cm)} + 3 \text{ in. (7.6 cm)}}{22 \text{ in. (55.9 cm)}} \\ \text{Corrected reading} &= 19 \text{ lb-ft (25.8 N}\cdot\text{m)} \div \frac{25 \text{ in. (63.5 cm)}}{22 \text{ in. (55.9 cm)}} \\ \text{Corrected reading} &= 19 \text{ lb-ft (25.8 N}\cdot\text{m)} \div 1.14 \\ \text{Corrected reading} &= 17 \text{ lb-ft (23.1 N}\cdot\text{m)} \end{aligned}$$

TORQUE LIMITS (Contd)

Table 4. Torque Specifications.

ITEM	LB-FT	LB-IN	N•m
Accessory drive pulley	40-45	—	54-61
Accessory drive pulley assembly	300-310	—	407-420
Accessory drive pulley locknut	300-310	—	407-420
Accessory drive pulley screws	40-45	—	54-61
Adapter	50	—	68
Adapter	20-25	—	27-34
Adjustable water pump pulley Hex-head screw	12-15	—	16-20
Locknut	45-55	—	61-75
Aftercooler Cover capscrews	25	—	34
Air aftercooler cover screw	25	—	34
Air compressor support	30-35	—	41-48
Air crossover hose clamp	—	30-35	3-4
Brass filter fittings	30-40	—	41-54
Cam follower capscrews	30-35	—	41-48
Camshaft support screws	25	—	34
Compact head capscrews	15-19	—	20-26
Connecting rod nut			
Step 1 Torque to	70-75		95-102
Step 2 Torque to	140-150		190-203
Step 3 Loosen all completely	—		—
Step 4 Torque to	25-30		34-41
Step 5 Torque to	70-75	—	95-102
Step 6 Torque to	140-150		190-203
Cover screw	—	96-132	11-15
Cylinder head bolt	15-19	—	20-26
Cylinder head capscrews			
Step 1	20-25		27-34
Step 2	80-100		109-136
Step 3	265-305	—	359-414
Diffuser plate	—	60-84	7-10
Flywheel bolt	19-21	—	26-29
Flywheel capscrews	190-200	—	258-271
Flywheel capscrews with hardened washers	200-220	—	271-298

TORQUE LIMITS (Contd)*Table 4. Torque Specifications (Contd).*

ITEM	LB-FT	LB-IN	N•m
Flywheel housing capscrews	140–160	—	190–217
Front cover	45–55	—	61–75
Front engine mount nut	270–295	—	366–400
Front support	55	—	75
Fuel crossover capscrews	3	—	4
Fuel filter bracket capscrews	25	—	34
Fuel fittings	—	150	17
Fuel injector orifice plug	—	8–10	11–14
Fuel pump front cover capscrews	9–11	—	12–15
Fuel pump mounting capscrews	30–35	—	41–48
Gear pump capscrews	11–13	—	15–18
Governor spring pack capscrews	9–11	—	12–15
Hose clamps			
Water pump mounting	30–35	—	41–48
Water manifold	30–35	—	41–48
Impeller housing screws		60	7
Impeller locknut	30	—	41
Injector adjusting screw	—	72	8
Injector stand stud	—	75	9
Intake manifold	20–25	—	27–34
Locknut, V-band clamp	—	58–68	7–8
Locknuts with ST-669 adapter	30–35	—	41–48
Main bearing capscrews			
Step 1 Torque to	85		115
Step 2 Torque to	250–260		339–353
Step 3 Loosen all 3 to 5 threads	—		—
Step 4 Torque to	85	—	115
Step 5 Torque to	250–260		339–353
Mounting capscrews	20–25	—	27–34
Mounting locknut	22–48	—	30–65
Oil cooler mounting capscrew	30–35	—	41–48
Oil drain fitting	50	—	68
Oil inlet fitting	20–25	—	27–34

TORQUE LIMITS (Contd)*Table 4. Torque Specifications (Contd).*

ITEM	LB-FT	LB-IN	N•m
Oil pan Captive washer screws Hex-head screws	35–40 15–20	—	48–54 20–27
Oil pan drainplug	60–70	—	81–95
Oil pump mounting capscrews	35–45	—	48–61
Oil suction tube mounting capscrews	30–35	—	41–48
Piston cooling nozzle hex-head screw	8–12	—	11–16
Rear engine mount nut	270–295	—	366–400
Retainer	53–57	—	72–77
Rocker cover capscrews Cork casket Cork and cubber casket	12–17 —	— 75–95	16–23 9–11
Rocker lever housing capscrews	55–65	—	75–88
Rotor locknut	20–24	—	27–33
Support screw	30–35	—	41–47
Throttle shaft plug	—	40–55	5–6
Transmission bolt	60	—	80
Transmission drainplug	18–24	—	25–32
Transmission main housing bolt	40	—	54
Universal joint bearing strap screw	36	—	49
Unloader body capscrews	—	96–120	11–14
Valve crosshead nuts with ST-669 adapter	22–26	—	30–35
Valve locknuts	40–45	—	54–61
V-band clamp	—	32–36	3–4
V-band clamp nut	10	—	14
Vibration damper bolts	190	—	258
Vibration damper mounting capscrews	180–200	—	244–271
Water header plates	—	72–96	8–11
Water inlet and outlet flange mounting Capscrews	27–32	—	37–43
Water inlet screw	32	—	43
Water outlet connection	15–20	—	20–27
Water outlet screw	20	—	27

END OF WORK PACKAGE

0053 00-9/10 blank

**DIRECT SUPPORT AND GENERAL SUPPORT
MAINTENANCE MANUAL
INCLUDING REPAIR PARTS AND SPECIAL TOOLS LIST (RPSTL)
FOR
M915, M915A1, M915A4, M916, M920 VEHICLES**

NSN 2815-01-082-8125	P/N NTC400-3652-02	CUMMINS NTC-400 BIG CAM I DIESEL ENGINE W/CONTAINER
NSN 2815-01-142-2745	P/N 11669835	CUMMINS NTC-400 BIG CAM III DIESEL ENGINE W/CONTAINER

WEAR LIMITS

SCOPE

This Work Package (WP) contains a table of wear limit information for the M915, M915A1, M916, M915A4, M920 vehicle. Parts exceeding these wear limits must be replaced.

WEAR LIMITS (Contd)*Table 1. Wear Limits.*

PART	DESCRIPTION/LOCATION	WEAR LIMIT
Cylinder sleeve	Maximum pit depth	.0625 in. (1.6 mm) maximum
Cylinder sleeve	Inside bore diameter	5.505 in. (13.983 cm) maximum
Main bearing halves	Thickness	0.1215 in. (3.0861 mm) actual limit
Connecting rod	Length	0.002 in. (0.050 mm) maximum
Connecting rod for twist	Between piston pin holding mandrel and dial indicator holding plate	0.20 in. (0.5078 mm) maximum
Camshaft follower roller	Outside diameter	1.2495 in. (31.737 mm) minimum 1.2505 in. (31.763 mm) maximum
Expansion plug	Flush with edge of hole	0.010 in. (0.254 mm) maximum
Rocker lever housing shaft bore	Inside diameter	1.1238 in. (2.855 cm) minimum – 1.1246 in. (2.857 cm) maximum
Rocker lever shaft	Outside diameter	1.1230 in. (2.552 cm) minimum – 1.1240 in. (2.855 cm) maximum
Turbocharger wheel and shaft	Runout	0.00005 in. (0.0127 mm) maximum
Turbocharger wheel and shaft and turbine housing	Clearance	0.005 in. (0.127 mm) minimum – 0.043 in. (0.092 mm) maximum
Turbocharger wheel and shaft	End play	0.006 in. (0.152 mm) minimum – 0.0018 in. (0.457 mm) maximum
Camshaft support	Inside diameter	1.757 in. (4.46 cm) maximum
Accessory drive shaft bushing	Surface outer dimension	1.310 in. (3.327 cm) minimum
Accessory drive gear to accessory drive housing	Allowable clearance	0.002 in. (0.051 mm) minimum – 0.012 in. (0.305 mm) maximum
Connecting rod	Bend or twist	0.002 in. (0.508 mm) maximum bend and 0.004 in. (0.102 mm) maximum twist
Connecting rod and crankshaft	End inside diameter	1.935 in. (49.149 mm) maximum
Cylinder housing inside bore	Diameter	3.6285 in. (9.2164 cm) maximum
Cylinder housing bore	Out-of-round	0.0015 in. (0.0381 mm) maximum
Piston pin bore	Diameter	0.6885 in. (17.4879 mm) maximum
Piston pin	Outside diameter	0.6876 in. (17.4625 mm) maximum
Piston ring	End gap	0.010 in. (0.254 mm) minimum – 0.020 in. (0.508 mm) maximum
Crankshaft front support journal	Diameter	1.872 in. (4.755 cm) minimum – 1.873 in. (4.757 cm) maximum
Crankshaft half coupling journal	Diameter	1.003 in. (2.548 cm) minimum – 1.0035 in. (2.549 cm) maximum

WEAR LIMITS (Contd)*Table 1. Wear Limits (Contd).*

PART	DESCRIPTION/LOCATION	WEAR LIMIT
Crankshaft rear coupling journal	Diameter	1.872 in. (4.755 cm) minimum – 1.873 in. (4.757 cm) maximum
Air compressor seat	Height	0.485 in. (12.319 mm) minimum
Air compressor seating area on seat	Height	0.270 in. (6.858 mm) minimum
Air compressor support thrust flange	Depth	1.307 in. (3.320 cm) minimum – 1.310 in. (3.327 cm) maximum
Fuel injector barrel ball	Seat depth	0.050 in. (1.27 mm) maximum
Solenoid valve seat	Width	0.015 in. (0.381 mm) minimum
Fuel pump weight-assist plunger	Protrusion	0.800 in. (20.32 mm) exact limit
Camshaft follower intake, injector, and exhaust	Concentricity of inside diameter with outside diameter	0.0020 in. (0.051 mm) must be within this measurement
Camshaft follower intake, injector, and exhaust	Squareness of sides with roller pin bore	0.0040 in. (0.102 mm) must be within this measurement
Fuel pump front cover gear and bushing	Clearance	0.002-0.005 in. (0.050-0.127 mm)
Cylinder block flatness	Between feeler gauge and cylinder block	0.02 in. (0.51 mm) max measured
Cylinder liner counterbore	Depth	0.412 in. (10.465 mm) maximum
Cylinder sleeve	Protrusion	0.006 in. (0.152 mm) maximum
Vibration damper	Thickness	0.125 in. (3.157 mm) maximum
Rear oil seal	Contact area	5.998 in. (15.234 cm) minimum
Front oil seal	Contact area	3.625 in. (9.207 cm) minimum
Rod bearing journal	Diameter	3.124 in. (7.933 cm) minimum
Main bearing journal	Diameter	4.489 in. (11.426 cm) minimum
Thrust ring	Thickness	0.245 in. (6.223 mm)
Crankshaft keyway	Width	0.375 in. (9.525 mm) maximum
Oil pump driveshaft	End play	0.002 in. (0.05 mm) minimum – 0.008 in. (0.20 mm) maximum
	Diameter	0.874 in. (22.20 mm) minimum
Idler shaft	Outside diameter	0.874 in. (22.20 mm) minimum
Air Aftercooler to intake manifold	Clearance	0.013 in. (0.330 mm) maximum
Turbocharger bearing housing	Length	2.986 in. (7.584 cm) minimum
V-band clamp to turbin housing	Clearance	0.035 in. (0.889 mm) minimum
Impeller to impeller housing	Clearance	0.006 in. (0.152 mm) minimum

WEAR LIMITS (Contd)*Table 1. Wear Limits (Contd).*

PART	DESCRIPTION/LOCATION	WEAR LIMIT
Injector cam follower roller	Inside diameter	0.704 in. (17.882 mm) maximum
Intake/exhaust roller	Pin diameter	0.4997 in. (12.692 mm) minimum
Injector roller	Pin diameter	0.6997 in. (17.772 mm) minimum
Intake/exhaust cam follower roller	Pin bore	0.4995 in. (12.687 mm) maximum
Injector cam follower roller	Pin bore	0.6997 in. (17.772 mm) maximum
Oil pump driveshaft	Diameter	0.874 in. (22.20 mm) minimum
Oil pump gear	Clearance	0.060 (1.52 mm) minimum – 0.070 in. (1.78 mm) maximum
Piston pin dowel	Diameter	0.220 in. (5.59 mm) minimum
Connecting rod bolt	Pilot area diameter	0.541 in. (13.74 mm) minimum
	Threaded area diameter	0.6245 (15.862 mm) minimum
Connecting rod	Inside diameter	3.3167 in. (8.4244 cm) maximum
Camshaft bearing	Journal diameter	2.495 in. (6.337 cm) minimum
Cam follower bushing	Inside diameter	0.7511 in. (19.078 mm) maximum
Intake/exhaust cam follower roller	Inside diameter	0.5015 in. (12.738 mm) maximum
Crankshaft gear	Step diameter	3.761 in. (9.552 cm) minimum
Crankshaft	Thrust flange	0.003 in. (0.076 mm) maximum
Piston ring to piston ring groove	Clearance	0.006 in. (0.15 mm) maximum
Piston	Outside diameter	5.480 in. (13.919 cm) minimum
Piston skirt	Outside diameter	5.493 in. (13.952 cm) minimum
Piston pin bore	Diameter	2.000 in. (5.080 cm) maximum
Piston pin	Outside diameter	1.9988 (5.0769 cm) minimum
Fuel gear pump idler shaft	Outside diameter	0.499 in. (12.70 mm) minimum
Fuel gear pump idler gear	Length	0.7483 in. (19.007 mm) minimum – 0.7486 in. (19.014 mm) maximum
Fuel gear pump	Gear body depth	0.7478 in. (18.994 mm) minimum – 0.7481 (19.002 mm) maximum
Fuel gear pump gear body shaft bore	Inside diameter	0.5016 in. (12.741 mm) maximum
Fuel gear pump	Driveshaft backlash	0.004 in. (0.1016 mm) maximum
	Driveshaft endplay	0.0009 in. (0.228 mm) minimum – 0.0015 in. (0.038 mm) maximum
Tachometer drive bushing	Inside diameter	0.752 in. (19.10 mm) maximum
Governor barrel	Diameter	0.002 in. (0.051 mm) smaller than governor barrel outside diameter

WEAR LIMITS (Contd)*Table 1. Wear Limits (Contd).*

PART	DESCRIPTION/LOCATION	WEAR LIMIT
Cylinder head	Distortion on mating surface	0.002 in. (0.051 mm) maximum
	Height	4.30 in. (11.024 cm) minimum
Turbocharger bearing housing bore	Inside diameter	0.876 in. (22.268 mm) maximum
Turbocharger wheel and shaft	Seal ring clearance	0.0005 in. (0.13 mm) maximum
Turbocharger wheel and shaft bearing area	Outside diameter	0.5611 in. (14.252 mm) minimum
Turbocharger thrust collar	Thickness	0.0980 in. (2.489 mm) minimum
Turbocharger oil slinger	Seal ring clearance	0.0005 in. (0.13 mm) maximum
Turbocharger turbine blade	Turbine housing clearance	0.008 in. (0.20 mm) minimum
Turbocharger impeller	Impeller housing clearance	0.006 in. (0.15 mm) minimum
Turbocharger wheel and shaft	End play	0.001 in. (0.254 mm) minimum – 0.004 in. (0.1 mm) maximum
Water pump housing	Bearing bore	2.45 in. (62.22 mm) maximum
Impeller must be smaller than water pump shaft impeller end to	Maintain a press fit between components	0.001 in. (0.025 mm)
Water pump shaft impeller	End outside diameter	0.6262 in. (15.905 mm) minimum – 0.6267 in. (15.918 mm) maximum
Water pump shaft	Pulley end outside diameter	0.6693 in. (17.000 mm) minimum – 0.6696 in. (17.008 mm) maximum
Water pump pulley must be smaller than water pump shaft pulley end to	Maintain a press fit between components	0.001 in. (0.025 mm)
Water pump pulley bore	Inside diameter	0.6663 in. (16.924 mm) minimum – 0.6673 in. (16.949 mm) maximum
Water pump impeller bore	Inside diameter	0.624 in. (15.85 mm) minimum – 0.6625 in. (15.88 mm) maximum
Impeller and water pump housing	Clearance	0.020 in. (0.508 mm) minimum – 0.040 in. (1.016 mm) maximum
Crankshaft and thrust bearing washers	Total end clearance	0.007 in. (0.178 mm) minimum – 0.018 in. (0.457 mm) maximum.
	Clearance for worn parts	0.022 in. (0.559 mm) maximum
Camshaft gear to crankshaft gear	Backlash	0.002 in. (0.051 mm) minimum – 0.020 in. (0.508 mm) maximum
Crankshaft and main bearings gasket	Thickness	0.014 in. (0.356 mm) minimum – 0.080 in. (2.032 mm) maximum
Connecting rod cap and crankshaft	Side clearance	0.004 in. (0.102 mm) minimum – 0.013 in. (0.330 mm) maximum

WEAR LIMITS (Contd)*Table 1. Wear Limits (Contd).*

PART	DESCRIPTION/LOCATION	WEAR LIMIT
Accessory drive gear to camshaft gear	Backlash	0.002 in. (0.051 mm) minimum – 0.016 in. (0.406 mm) maximum
Oil pump drive gear	Backlash between gears	0.002 in. (0.051 mm) minimum – 0.016 in. (0.406 mm) maximum
Oil pan mounting flange on gear cover with oil pan mounting flange on cylinder block	Alignment	Gear cover must be even with front cylinder block flange within 0.004 in. (0.102 mm)
Mounting flange of camshaft support and gear cover	Thickness of shim pack	0.008 in (0.203 mm) minimum – 0.13 in. (3.302 mm) maximum
Flywheel, flexplate, and flywheel housing dowel pins	Outside diameter	0.5005 in. (12.713 mm) minimum
Crankshaft	Alignment must not exceed	0.008 in. (0.203 mm)

CHAPTER 4

SUPPORTING INFORMATION

FOR

ENGINE, DIESEL

CUMMINS MODEL NTC-400

M915, M915A1, M915A4,

M916, M920 VEHICLES

CHAPTER 4

SUPPORTING INFORMATION

<u>Work Package Title</u>	<u>Work Package/Page No.</u>
References	WP 0055 00-1
Repair Parts Introduction	WP 0056 00-1
Repair Parts Scope	WP 0057 00-1
Repair Parts and Special Tools List (RPSTL)	WP 0058 00-1
National Stock Number (NSN) Index	WP 0059 00-1
Expendable and Durable Items	WP 0060 00-1
Tools and Special Tools	WP 0061 00-1
Mandatory Replacement Parts	WP 0062 00-1

**DIRECT SUPPORT AND GENERAL SUPPORT
MAINTENANCE MANUAL
INCLUDING REPAIR PARTS AND SPECIAL TOOLS (RPSTL)**

FOR

M915, M915A1, M915A4, M916, M920 VEHICLES

NSN 2815-01-082-8125	P/N NTC400-3652-02	CUMMINS NTC-400 BIG CAM I DIESEL ENGINE W/CONTAINER
NSN 2815-01-142-2745	P/N 11669835	CUMMINS NTC-400 BIG CAM III DIESEL ENGINE W/CONTAINER

REFERENCES

SCOPE

This Work Package (WP) lists all forms, technical manuals, and other publications referenced in this TM.

REFERENCES (Contd)**FORMS**

DA Form 1693	Engineering Change Proposal (Short Form)
DA Form 2028	Recommended Changes to DA Publications and Blank Forms
DA Form 2404	Equipment Inspection and Maintenance Worksheet
DA Form 2408-9	Equipment Control Record
SF 368	Quality Deficiency Report

TECHNICAL MANUALS

TM 9-247	Materials Used for Cleaning, Preserving, Abrading, and Cementing
TM 740-90-1	Administrative Storage of Equipment
TM 750-244-6	Procedures for Destruction of Tank-Automotive Equipment
TM 9-2320-273-10	Operator's Manual
TM 9-2320-273-20	Organizational Maintenance
TM 9-2320-273-34	Direct Support and General Support Maintenance
TM 9-2320-283-10	Operator's Manual
TM 9-2320-283-12	Lubrication Order
TM 9-2320-283-20	Organizational Maintenance
TM 9-2320-283-34	Direct Support and General Support Maintenance

OTHER PUBLICATIONS

AR 750-22	Army Oil Analysis Program
CTA 50-970	Expendable/Durable Items
DA PAM 738-750	Functional Users Manual for The Army Maintenance Management System (TAMMS)
E-1417	Standard Practice for Liquid Penetrant Examination
E-1444	Standard Practice for Magnetic Particle Examination
FM 9-207	Operation and Maintenance of Ordnance Materiel in Cold Weather
NASM33537	Standard Assembly Dimensions for Insert, Screw Thread, Helical Coil, Course and Fine Thread
TB 9-2300-295-15/21	Commercial Warranties
TB 43-750-651	Use of Antifreeze Solutions and Cleaning Compounds in Engine Cooling System
TB 43-0212	Purging and Cleaning of Fuel Tanks

END OF WORK PACKAGE

**DIRECT SUPPORT AND GENERAL SUPPORT
MAINTENANCE MANUAL
INCLUDING REPAIR PARTS AND SPECIAL TOOLS LIST (RPSTL)**

FOR

M915, M915A1, M915A4, M916, M920 VEHICLES

NSN 2815-01-082-8125 P/N NTC400-3652-02 CUMMINS NTC-400 BIG CAM I DIESEL ENGINE
W/CONTAINER

NSN 2815-01-142-2745 P/N 11669835 CUMMINS NTC-400 BIG CAM III DIESEL ENGINE
W/CONTAINER

REPAIR PARTS INTRODUCTION

SCOPE

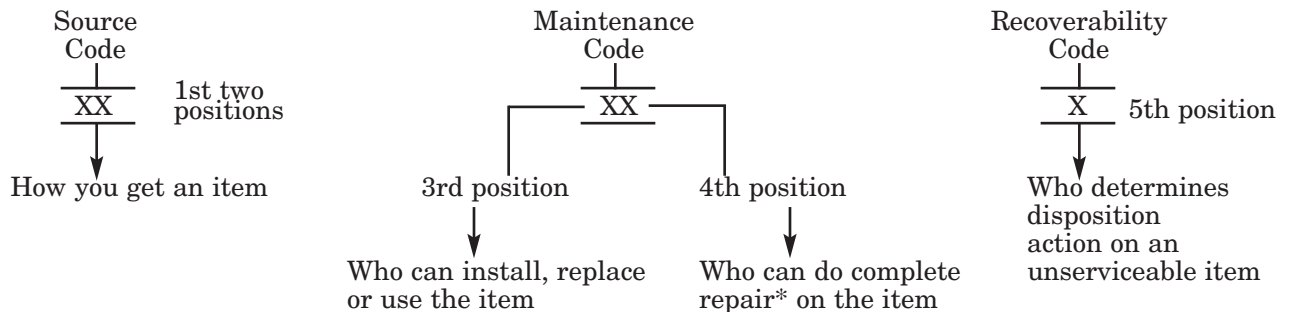
The repair parts information in this Technical Manual (TM) consists of this Introduction Work Package (WP) and a separate WP containing the engine repair parts list. The introductory material provides the information needed to interpret and understand the repair parts lists. Each column used in the repair parts list is identified and its purpose explained. All codes are listed and their meaning is defined. This introductory material should be read before proceeding to the Repair Parts WP.

The Repair Parts WP lists and authorizes parts required for TM overhaul of the Cummins NTC-400 diesel engine. It authorizes the requisitioning, issue, and disposition of repair parts as indicated by the Source, Maintenance, and Recoverability (SMR) codes.

EXPLANATION OF COLUMNS IN THE REPAIR PARTS LIST

Item No. (Column 1). Indicates the number used to identify items called out in the illustration.

SMR Code (Column 2). A 5-position code containing supply/requisitioning information, maintenance category authorization criteria, and disposition instruction, as shown in the following breakout:



*Complete Repair: Maintenance capacity, capability, and authority to perform all corrective maintenance tasks of the repair function in a use/user environment in order to restore serviceability to a failed item.

REPAIR PARTS INTRODUCTION (Contd)

Source Code. The source code tells you how to get an item needed for maintenance, repair, or overhaul of an end item/equipment. Explanations of source codes follows.

Code	Explanation
PA	Stocked items; use the applicable NSN to request/requisition items with these source codes. They are authorized to the category indicated by the code entered in the third position of the SMR code.
PB	
PC**	
PD	
PE	
PF	
PG	
KD	
KF	
KB	
MO- (Made at Unit Level)	Items with these codes are not to be requested/requisitioned individually. They are part of a kit which is authorized to the maintenance category indicated in the third position of the SMR code. The complete kit must be requisitioned and applied.
MF- (Made at DS Level)	
MH- (Made at Specialized Repair Act (SRA))	
MD- (Made at Depot)	
AO- (Assembled by Unit Level)	Items with these codes are not to be requested/requisitioned individually. They must be made from bulk material which is identified by the part number in the DESCRIPTION AND USABLE ON CODE (UOC) column and listed in the bulk material group of the repair parts list. If the item is authorized to you by the third position code of the SMR code, but the source code indicates it is made at a higher level, order the item from the higher level of maintenance.
AF- (Assembled by DS Level)	
AH- (Assembled by GS Level)	
AL- (Assembled by SRA)	
AD- (Assembled by Depot)	
XA- Do not requisition an XA-coded item. Order the next higher assembly. (Also, refer to the note below.)	Items with these codes are not to be requested/requisitioned individually. The parts that make up the assembled item must be requisitioned or fabricated and assembled at the level of maintenance indicated by the source code. If the third position code of the SMR code authorized you to replace the item, but the source code indicates the item is assembled at a higher level, order the item from the higher level of maintenance.
XB- If an XB item is not available from salvage, order it using the Commercial and Government Entity Code (CAGEC) and Part Number (P/N) given.	
XC- Installation drawing, diagram, instruction sheet, field service drawing, that is identified by manufacturer's part number.	
XD- Item is not stocked. Order an XD-coded item through normal supply channels using the CAGEC and part number given, if no National Stock Number (NSN) is available.	

NOTE

Cannibalization or controlled exchange, when authorized, may be used as a source of supply for items with the above source codes, except for source code XA.

Maintenance Code. Maintenance codes tell you the level(s) of maintenance authorized to USE and REPAIR support items. The maintenance codes are entered in the third and fourth positions of the SMR code as follows:

- **Third Position.** The maintenance code entered in the third position tells you the lowest maintenance level authorized to remove, replace, and use an item. The maintenance code entered in the third position will indicate authorization to one of the following levels of maintenance.

Code	Application/Explanation
C	– Crew or operator maintenance done within organizational maintenance.
O	– Unit level can remove, replace, and use the item.
F	– Direct support level can remove, replace, and use the item.
H	– General support level can remove, replace, and use the item.
L	– Specialized repair activity can remove, replace, and use the item.
D	– Depot level can remove, replace, and use the item.

REPAIR PARTS INTRODUCTION (Contd)

- **Fourth Position.** The maintenance code entered in the fourth position tells you whether or not the item is to be repaired and identifies the lowest maintenance level with the capability to do complete repair (i.e., perform all authorized repair functions).

NOTE

Some limited repair may be done on the item at a lower level of maintenance, if authorized by the Maintenance Allocation Chart (MAC) and SMR codes. This position will contain one of the following maintenance codes.

Code	Application/Explanation
O	– Unit is the lowest level that can do complete repair of the item.
F	– Direct support is the lowest level that can do complete repair of the item.
H	– General support is the lowest level that can do complete repair of the item.
L	– Specialized repair activity (designate the specialized repair activity) is the lowest level that can do complete repair of the item.
D	– Depot is the lowest level that can do complete repair of the item.
Z	– Nonrepairable. No repair is authorized.
B	– No repair is authorized. (No parts or special tools are authorized for the maintenance of a B-coded item.) However, the item may be reconditioned by adjusting, lubricating, etc., at the user level.

Recoverability Code. Recoverability codes are assigned to items to indicate the disposition action on unserviceable items. The recoverability code is entered in the fifth position of the SMR code as follows:

Recoverability Code	Application/Explanation
Z	– Nonrepairable item. When unserviceable, condemn and dispose of the item at the level of maintenance shown in third position of SMR code.
O	– Repairable item. When uneconomically repairable, condemn and dispose of the item at unit level.
F	– Repairable item. When uneconomically repairable, condemn and dispose of the item at the direct support level.
H	– Repairable item. When uneconomically repairable, condemn and dispose of the item at the general support level.
D	– Repairable item. When beyond lower level repair capability, return to depot. Condemnation and disposal of item not authorized below depot level.
L	– Repairable item. Condemnation and disposal not authorized below specialized repair activity (SRA).
A	– Item requires special handling or condemnation procedures because of specific reasons (e.g., precious metal content, high dollar value, critical material, or hazardous material). Refer to appropriate manuals/directives for specific instructions.

REPAIR PARTS INTRODUCTION (Contd)

NSN (Column 3). The NSN for the item is listed in this column.

CAGEC (Column 4). A 5-digit numeric code used to identify the manufacturer, distributor, or Government agency/activity, that supplies the item.

Part Number (Column 5). Indicates the primary number used by the manufacturer (individual, company, firm, corporation, or Government activity), which controls the design and characteristics of the item by means of its engineering drawings, specifications standards, and inspection requirements to identify an item or range of items. Part numbers not available (N/A) will be provided as updates to this manual when available.

NOTE

When you use an NSN to requisition an item, the item you receive may have a different part number from the part ordered.

Description and Usable On Code (UOC) (Column 6). This column includes the following information:

- 1 The Federal item name and, when required, a minimum description to identify the item.
- 2 Items that are included in kits and sets are listed below the name of the kit or set.
- 3 Spare/repair parts that make up an assembled item are indented and listed immediately following the assembled item line entry.
- 4 Part numbers for bulk materials are referenced in this column in the line item entry for the item to be manufactured/fabricated.
- 5 When the item is not used with all serial numbers of the same model, the effective serial numbers are shown on the last line(s) of the description (before UOC).
- 6 The statement END OF FIGURE appears just below the last item description in column 6 for a given figure in both the repair parts list and special tools list work packages.

QTY (Column 7). The QTY (quantity per figure column) indicates the quantity of the item used in the breakout shown on the illustration figure, which is prepared for a functional group, subfunctional group, or an assembly. The letter V appearing in this column in lieu of a quantity indicates that the quantity is variable and the quantity may change from application to application.

HOW TO LOCATE REPAIR PARTS

When NSN or P/N is not known:

First. Determine the assembly or subassembly to which the item belongs.

Second. Find the figure covering the assembly or subassembly to which the item belongs.

Third. Identify the item on the figure and use the Figure and Item Number Index to find the NSN.

Fourth. Look in the repair parts list work package for the figure and item numbers. The NSNs and part numbers are on the same line as the associated item numbers.

**DIRECT SUPPORT AND GENERAL SUPPORT
MAINTENANCE MANUAL
INCLUDING REPAIR PARTS AND SPECIAL TOOLS LIST (RPSTL)**

FOR

M915, M915A1, M915A4, M916, M920 VEHICLES

NSN 2815-01-082-8125	P/N NTC400-3652-02	CUMMINS NTC-400 BIG CAM I DIESEL ENGINE W/CONTAINER
NSN 2815-01-142-2745	P/N 11669835	CUMMINS NTC-400 BIG CAM III DIESEL ENGINE W/CONTAINER

REPAIR PARTS

SCOPE

This Repair Parts Work Package (WP), illustrations and parts lists are organized into functional groups that contain related parts. For example, components related to the Cummins NTC-400 diesel engine will be shown in one illustration, while those related to the container will be found on a separate page.

TABLE OF CONTENTS

	Illus/ Fig	Page
GROUP 01 ENGINE		
0100 ENGINE ASSEMBLY		
Dressed Engine and Container	01	1-1
0101 CRANKCASE, BLOCK, AND CYLINDER HEAD		
Engine Block	2	2-1
Cylinder Head Assembly	3	3-1
0102 CRANKSHAFT		
Crankshaft Assembly	4	4-1
0103 FLEXDISK, RING GEAR AND HOUSING		
Flexdisk, Ring Gear and Housing	5	5-1
0104 PISTON AND CONNECTING ROD ASSEMBLY		
Piston and Connecting Rod Assembly	6	6-1
0105 VALVES, CAMSHAFTS AND TIMING SYSTEM		
Camshaft Assembly and Followers	7	7-1
Rocker Arm Assembly	8	8-1
Rocker Cover	9	9-1
0106 CRANKCASE, BLOCK AND CYLINDER HEAD		
Oil Cooler and Filter, Big Cam III	10	10-1
Oil Cooler and Filter, Big Cam I	11	11-1
Oil Pan, Dipstick, and Breather Tube	12	12-1
Oil Lubricating Pump	13	13-1
0108 MANIFOLDS		
Air Aftercooler	14	14-1
Exhaust Manifolds	15	15-1
0109 ACCESSORY DRIVING MECHANISM		
Gear Cover	16	16-1
Accessory Drive Pulley and Fan Clutch	17	17-1
0112 ENGINE BRAKE		
Engine Retarder	18	18-1
0121 COMPRESSOR ASSEMBLY		
Air Compressor Lines and Fittings	19	19-1
Air Compressor and Governor Assembly	20	20-1
0301 CARBURATOR, FUEL INJECTOR		
Fuel Injector	21	21-1
0302 FUEL PUMP		
Fuel Lines and Fittings	22	22-1
Fuel Pump	23	23-1
Fuel Pump Main Housing	24	24-1
Fuel Gear Pump	25	25-1

TABLE OF CONTENTS (Contd)

	Illus/ Fig	Page
0305 SUPERCHARGER, BLOWER, TURBOCHARGER, OR ALTITUDE COMPENSATOR		
Turbocharger and Component Parts	26	26-1
Turbocharger Assembly	27	27-1
Turbocharger Assembly, Big Cam III	28	28-1
0306 TANKS, LINES, FITTINGS AND HEADERS		
Solenoid Valves	29	29-1
0308 ENGINE SPEED GOVERNOR AND CONTROL		
Fuel Pump Front Cover, Governor, and Tach Drive	30	30-1
0309 FUEL PUMP DAMPER, HEAD, AND FUEL FILTER		
Fuel Pump Damper, Head, and Fuel Filter	31	31-1
0311 WHEEL ASSEMBLY		
Ether Quick-Start Kit	32	32-1
0312 FUEL CONTROL LEVER		
Fuel Control Lever	33	33-1
0503 WATER MANIFOLD, HEADERS, THERMOSTATS AND HOUSING GASKET		
Thermostat Housing, Water Manifold, and Component Parts	34	34-1
Water Filter and Component Parts	35	35-1
0504 WATER PUMP		
Water Pump and Idler	36	36-1
GROUP 94 REPAIR KITS		
9401 REPAIR KITS		KIT-1
GROUP 95 BULK MATERIAL		BULK-1
GROUP		
2604 DIRECT SUPPORT SPECIAL TOOLS		
Direct Support Special Tools-1	37	37-1
Direct Support Special Tools-2	38	38-1
Direct Support Special Tools-3	39	39-1
Direct Support Special Tools (Supplemental) Big Cam I	40	40-1
General Support Special Tools-1	41	41-1
General Support Common Tools-2	42	42-1
General Support Special Tools-3	43	43-1
General Support Special Tools-1 (Supplemental), Big Cam I	44	44-1
General Support Special Tools-2 (Supplemental), Big Cam I	45	45-1
General Support Special Tools-3 (Supplemental)	46	46-1
Direct and General Support Special Tools-1	47	47-1
Direct Support Special Tools-2	48	48-1
Direct Support Special Tools-3	49	49-1
General Support Special Tools-1	50	50-1
General Support Special Tools-2	51	51-1
General Support Special Tools-3	52	52-1
General Support Special Tools-4	53	53-1

1 — 2
thru
10

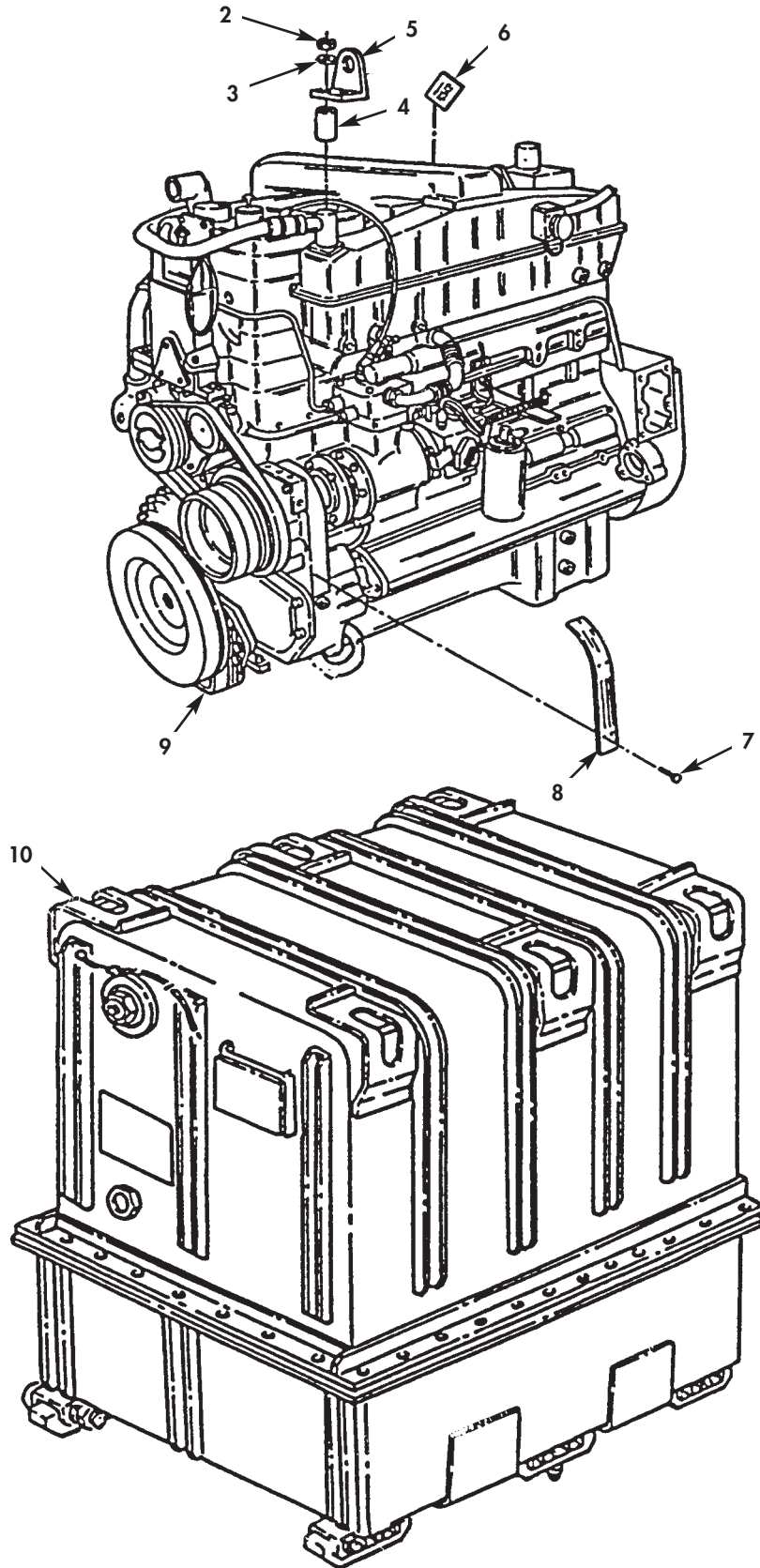


Figure 1. Dressed Engine and Container.

(1) ITEM NO	(2) SMR CODE	(3) NSN	(4) CAGEC	(5) PART NUMBER	(6) DESCRIPTION AND USABLE ON CODE(UOC) GROUP 01 ENGINE GROUP 0100 ENGINE ASSEMBLY FIG. 1 DRESSED ENGINE AND CONTAINER	(7) QTY
1	PAFHD	2815-01-438-1517	19207	57K3603	ENGINE,DIESEL BIG CAM III.....	1
2	PAOZZ	5310-01-144-6115	75078	001094	.NUT,PLAIN,CONE SEAT.....	4
3	PAOZZ	5310-00-584-5272	96906	MS35338-48	.WASHER,LOCK.....	4
4	PAOZZ	5365-01-147-5030	75078	001234	.SPACER,SLEEVE.....	4
5	PAOZZ	5342-00-404-2946	15434	170226	.BRACKET,ENGINE LIFT.....	2
6	XBOZZ		15434	3003480	.LABEL BIG CAM I.....	1
7	PAOZZ	5305-00-804-6318	15434	S-2286	.SCREW.....	5
8	PAOZZ	7690-01-094-6720	15434	3074214	.MARKER,IDENTIFICATI BIG CAM I.....	1
8	PAOZZ	9905-01-147-0933	15434	3027282	.PLATE,IDENTIFICATIO BIG CAM III...	1
9	XAFHH	2815-01-142-2745	19207	11669835	.ENGINE,DIESEL DRESSED, W/O CONTAINER, BIG CAM III.....	1
10	PAFFF	8115-01-349-2459	19207	12389942	.BOX,SHIPPING WITHOUT ENGINE.....	1

END OF FIGURE

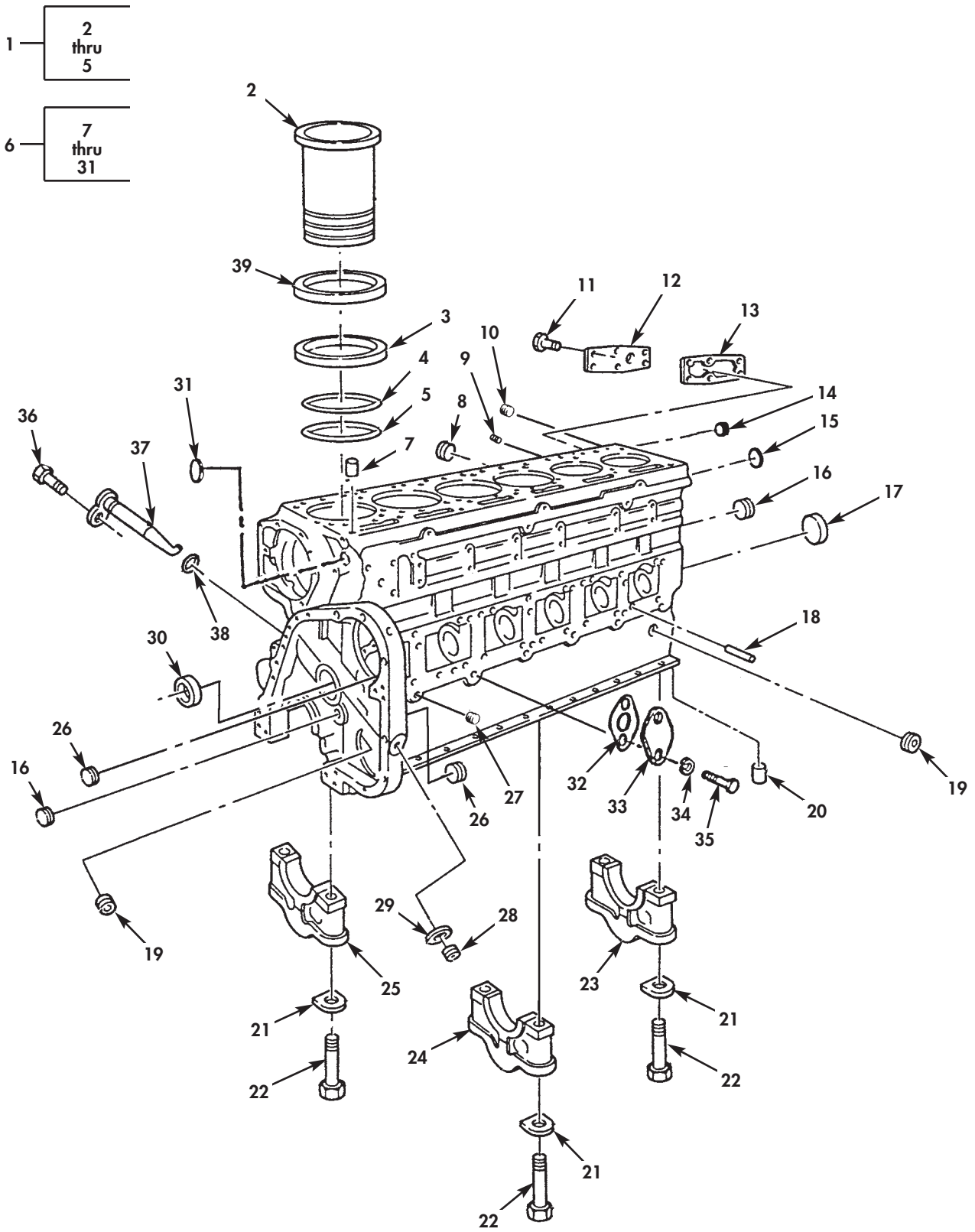


Figure 2. Engine Block.

(1) ITEM NO	(2) SMR CODE	(3) NSN	(4) CAGEC	(5) PART NUMBER	(6) DESCRIPTION AND USABLE ON CODE(UOC) GROUP 0101 CRANKCASE, BLOCK AND CYLINDER HEAD FIG. 2 ENGINE BLOCK	(7) QTY
1	PAHHH	2815-00-011-7786	15434	3801826	CYLINDER SLEEVE ASSEMBLY.....	6
2	XAHZZ		15434	213740.	.CYLINDER SLEEVE.....	1
3	PAHZZ	5330-00-064-4399	15434	215090	.GASKET.....	1
4	PAHZZ	5330-01-049-0466	15434	3008998	.PACKING BLACK.....	1
5	PAHZZ	5331-00-058-1767	15434	149105PC183049	.O-RING RED.....	1
6	PAHHH	2815-01-105-8768	15434	3013909	ENGINE BLOCK ASSEMB BIG CAM I....	1
6	PAHHH	2815-01-141-9370	15434	3801310	ENGINE BLOCK,DIESEL BIG CAM III...	1
7	PAHZZ	5315-00-281-7610	15434	68445	.PIN,GROOVED,HEADLES HEAD TO BLOCK	6
8	PAHZZ	4730-01-214-7081	15434	3008469	.PLUG,PIPE 3/4".....	1
9	PAHZZ	4730-00-081-9618	79470	C3159X2	.PLUG,PIPE 1/8-27 NPTF.....	7
10	PAHZZ	4730-00-954-1281	02978	MS49005-4	.PLUG,PIPE 1/4-18 NPTF.....	3
11	PAHZZ	5305-01-112-9021	15434	3013904	.SCREW WITH CAPTIVE WASHER, 1/4-20 X 5/8.....	6
12	PAHZZ	5340-00-799-0843	15434	132019	.COVER,ACCESS WATER HEADER.....	1
13	PFHZZ	5330-00-537-2382	15434	70089-1	.GASKET WATER HEADER COVER PART OF KIT P/N 3801235.....	1
14	PAHZZ	4730-00-203-0549	15434	S-966E	.PLUG,PIPE 1-1/2 NPT.....	1
15	PAHZZ	5340-00-050-1600	96906	MS35648-8	.PLUG,EXPANSION.....	1
16	PAHZZ	4730-01-161-5115	15434	3013786	.PLUG,PIPE 3/8 NPT.....	6
17	PAHZZ	5340-01-145-9362	15434	3011952	.CAP,PROTECTIVE,DUST CAM HOLE....	1
18	PAHZZ	5315-00-014-1195	15434	68585	.PIN,STRAIGHT,HEADLE CAM FOLLOWER.	6
19	PAHZZ	4730-00-221-2139	72452	1459-259	.PLUG,PIPE 1/2-14 NPT.....	2
20	PAHZZ	5315-00-532-9388	64104	B2568	.PIN,STRAIGHT,HEADLE REAR MAIN BEARING CAP TO BLOCK.....	2
21	PAHZZ	5310-00-356-1447	15434	3009213	.WASHER,LOCK BLOCK,DIESEL ENGINE,BIG CAM I.....	14
21	PAHZZ	5310-00-082-1882	15434	140218	.WASHER,FLAT BLOCK,DIESEL ENGINE. BIG CAM III.....	14
22	PAHZZ	5305-01-179-2380	15434	208346	.SCREW,CAP,HEXAGON H BIG CAM III..	14
23	PFHZZ	3130-01-146-1228	15434	3008049	.CAP,PILLOW BLOCK NUMBER 7. BIG CAM III.....	1
24	PAHZZ	3130-00-408-9041	15434	42646	.CAP,PILLOW BLOCK MAIN 2,4 AND 6,BLOCK,DIESEL ENGINE. BIG CAM I...	3
24	PBHZZ	3130-01-146-4504	15434	3008048	.CAP,BEARING NUMBER 2, 4 AND 6. BIG CAM III.....	3
25	PAHZZ	2815-00-484-8359	15434	42645	.CAP,MAIN BEARING MAIN 1,3 AND 5,BLOCK,DIESEL ENGINE. BIG CAM I...	3
25	PBHZZ	3130-01-146-1150	15434	3008047	.CAP,PILLOW BLOCK NUMBER 1, 3 AND 5. BIG CAM III.....	3
26	PAHZZ	4730-00-801-8186	15434	S-915-A	.PLUG,PIPE.....	2
27	PAHZZ	4730-00-018-9566	15434	S911B	.PLUG,PIPE 1/8-27 NPT.....	2
28	PAHZZ	5365-01-150-6257	15434	210884	.PLUG,MACHINE THREAD HEXAGON HEAD, 7/8-18 UNS-2A.....	1
29	PCHZZ	5310-00-197-5304	15434	66292	.WASHER,FLAT.....	1
30	PFHZZ	3120-01-079-6823	15434	3011951	.BEARING,SLEEVE CAMSHAFT,NUMBER 7. BIG CAM III PART OF KIT P/N 3801106	1
30	PFHZZ	3120-01-208-8102	15434	3028075	.BUSHING,SLEEVE NUMBER 1,2,4 AND 6. BIG CAM III PART OF KIT P/N 3801106	4
30	PFHZZ	3120-01-208-8103	15434	3028269	.BUSHING,SLEEVE NUMBER 3 AND 5.BIG CAM III PART OF KIT P/N 3801106...	2
31	PAHZZ	5340-00-276-5847	15434	S719	.PLUG,EXPANSION 1".....	1
32	PAHZZ	5330-00-171-7267	15434	67963	GASKET.....	1
33	PFHZZ	4730-00-404-2909	15434	13264800	FLANGE,PIPE,BLIND.....	1
34	PAHZZ	5310-00-261-7340	15434	S604	WASHER,LOCK 3/8.....	2
35	PAHZZ	5305-00-546-6698	15434	S129	SCREW,CAP,HEXAGON H.....	2
36	PAHZZ	5305-01-144-6204	34623	5731317	SCREW,SELF-LOCKING.....	6

(1) Item NO	(2) SMR Code	(3) NSN	(4) CAGEC	(5) Part Number	(6) DESCRIPTION AND USABLE ON CODE (UOC)	(7) Qty
37	PAHZZ	2910-01-146-7955	15434	3013591	NOZZLE,PISTON COOLI.....	6
38	PCHZZ	5331-01-145-5377	15434	3007442	O-RING PISTON COOLING NOZZLE PART OF KIT P/N 3801235.....	1
39	PBHZZ	5365-01-147-9802	15434	3019955	GASKET CYLINDER LINER, 0.007.....	6
39	PBHZZ	5365-01-147-2497	15434	3019958	SPACER,RING CYLINDER LINER, 0.020.	6
39	PBHZZ	5365-01-147-2496	15434	3019957	SHIM CYLINDER LINER, 0.009.....	6
39	PBHZZ	5365-00-488-0799	15434	3019956	SPACER,RING CYLINDER LINER, 0.008.	6
39	PBHZZ	5365-01-147-2495	15434	3019960	SHIM CYLINDER LINER, 0.062.....	6
39	PBHZZ	5365-01-148-8353	15434	3019959	SHIM CYLINDER LINER, 0.031.....	6

END OF FIGURE

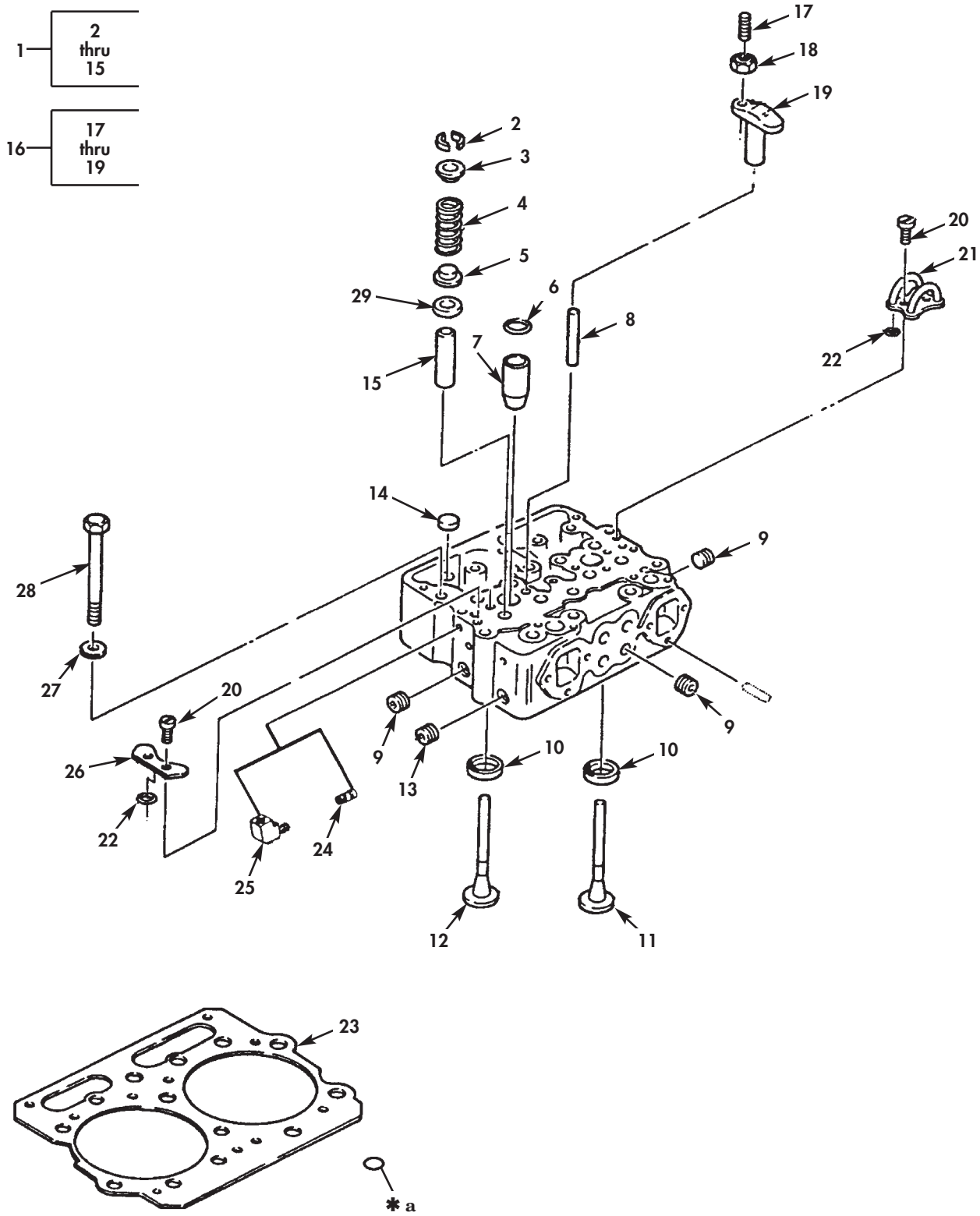


Figure 3. Cylinder Head Assembly.

(1) ITEM NO	(2) SMR CODE	(3) NSN	(4) CAGEC	(5) PART NUMBER	(6) DESCRIPTION AND USABLE ON CODE(UOC)	(7) QTY
GROUP 0101 CRANKCASE, BLOCK AND CYLINDER HEAD						
FIG. 3 CYLINDER HEAD ASSEMBLY						
1	PAFFD	2815-01-085-8282	15434	3041993	CYLINDER HEAD,DIESE.....	3
2	PAFZZ	2805-00-293-9699	77220	H231	.LOCK,VALVE SPRING R	16
3	PAFZZ	5340-00-933-3009	15434	170296	.SEAT,HELICAL COMPRE.....	8
4	PAFZZ	5360-00-009-9270	15434	211999	.SPRING,HELICAL,COMP.....	8
5	PAFZZ	5340-00-632-6239	15434	172034	.SEAT,HELICAL COMPRE.....	8
6	PCFZZ	5331-01-072-4436	15434	3007759	.O-RING PART OF KIT P/N 3804280....	2
7	PAFZZ	2910-01-146-0048	15434	3011934	.SLEEVE,COOLING,FUEL SLEEVE,COOLING ,FUEL BIG CAM III.....	2
8	PAFZZ	5315-00-866-5015	15434	123558	.PIN,STRAIGHT,HEADLE VALVE CROSSHEAD.....	4
9	PAFZZ	5340-01-087-0681	15434	213395	.PLUG,EXPANSION 1.010-1.012.....	6
10	PAFZZ	2815-00-085-7434	15434	3017759	.INSERT,ENGINE VALVE INTAKE AND EXHAUST.....	8
10	PAFZZ	2815-00-132-0240	15434	3014622	.INSERT,ENGINE VALVE 0.010 OVERSIZE V	
10	PAFZZ	2815-01-127-1060	15434	3014623	.INSERT,VALVE SEAT 0.020 OVERSIZE.. V	
10	PAFZZ	2815-01-127-3597	15434	3014624	.INSERT,ENGINE VALVE 0.030 OVERSIZE V	
10	PAFZZ	2815-01-127-3598	15434	3014625	.INSERT,VALVE SEAT 0.040 OVERSIZE.. V	
11	PAFZZ	2815-01-354-2702	15434	3803512	.VALVE,POPPET,ENGINE INTAKE BIG CAM III.....	4
12	PAFZZ	2815-00-962-5623	15434	3803524	.VALVE,POPPET,ENGINE EXHAUST.....	4
13	PAFZZ	5340-01-087-0682	15434	213394	.PLUG,EXPANSION 3/4.....	1
14	PAFZZ	5340-01-086-6193	15434	216524	.PLUG,EXPANSION 1-1/4.....	2
15	PAFZZ	2815-01-085-2618	15434	3006456	.GUIDE,VALVE STEM INTAKE AND EXHAUST STANDARD.....	8
15	PFFZZ	2815-01-490-0416	15434	3006457	.GUIDE,VALVE STEM 0.010 OVERSIZE... V	
15	XDFZZ		15434	3006458	.GUIDE,VALVE STEM 0.020 OVERSIZE... V	
16	PAFZZ	2815-01-159-1789	15434	3030038	VALVE,CROSSHEAD ASS INTAKE AND EXHAUST.....	12
17	PAFZZ	5305-00-062-4378	15434	147389	.SETSCREW 3/8-24 UNF-2A THREAD.....	1
18	PAFZZ	5310-00-426-3990	15434	203131	.NUT,CROSS HD.....	1
19	PAFZZ	2815-01-085-3733	75078	011573	.CROSSHEAD,VALVE.....	1
20	PAFZZ	5305-00-477-6769	15434	70772	SCREW,ASSEMBLED WAS 1/4-20 X 1/2...	12
21	PAFZZ	2910-00-928-3505	15434	147100	CROSSOVER,FUEL.....	2
22	PCFZZ	5331-00-143-8485	15434	131026	O-RING PART OF KIT P/N 4024958 PART OF KIT P/N 3804280.....	12
23	PAFZZ	5330-01-080-5021	15434	3349819	GASKET CYLINDER HEAD STANDARD PART OF KIT P/N 4024958 PART OF KIT 3804280.....	3
23	XDFZZ		15434	3040180	GASKET,CYLINDER HEA 0.010-0.020 OVERSIZE.....	3
24	PAFZZ	4730-00-018-9566	15434	S-911-B	PLUG,PIPE 1/8-27 NPT.....	10
25	PAFZZ	4730-00-444-1710	15434	181213	ELBOW,PIPE TO TUBE FUEL LINE TO HEAD.....	2
26	PAFZZ	2815-01-146-4164	15434	135308	PLATE,FUEL CROSSOVE.....	2
27	PAFZZ	5310-00-285-8833	17576	538174	WASHER,FLAT 0.708-0.710.....	36
28	PAFZZ	5305-01-145-8379	15434	3013623	SCREW,CAP,HEXAGON H.....	36
29	XDFZZ		15434	68803-A	VALVE SPRING SPACER.....	1

END OF FIGURE

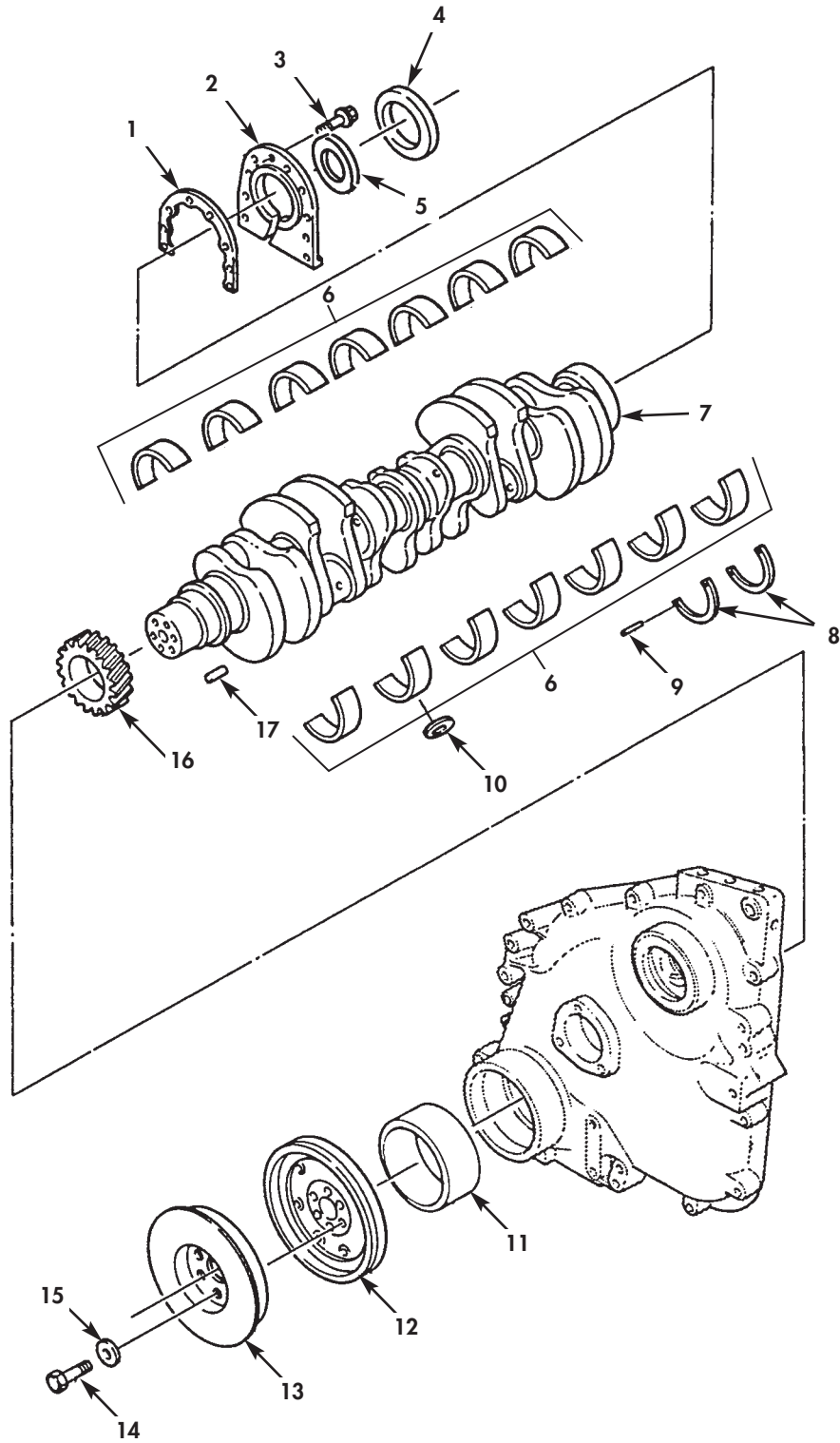
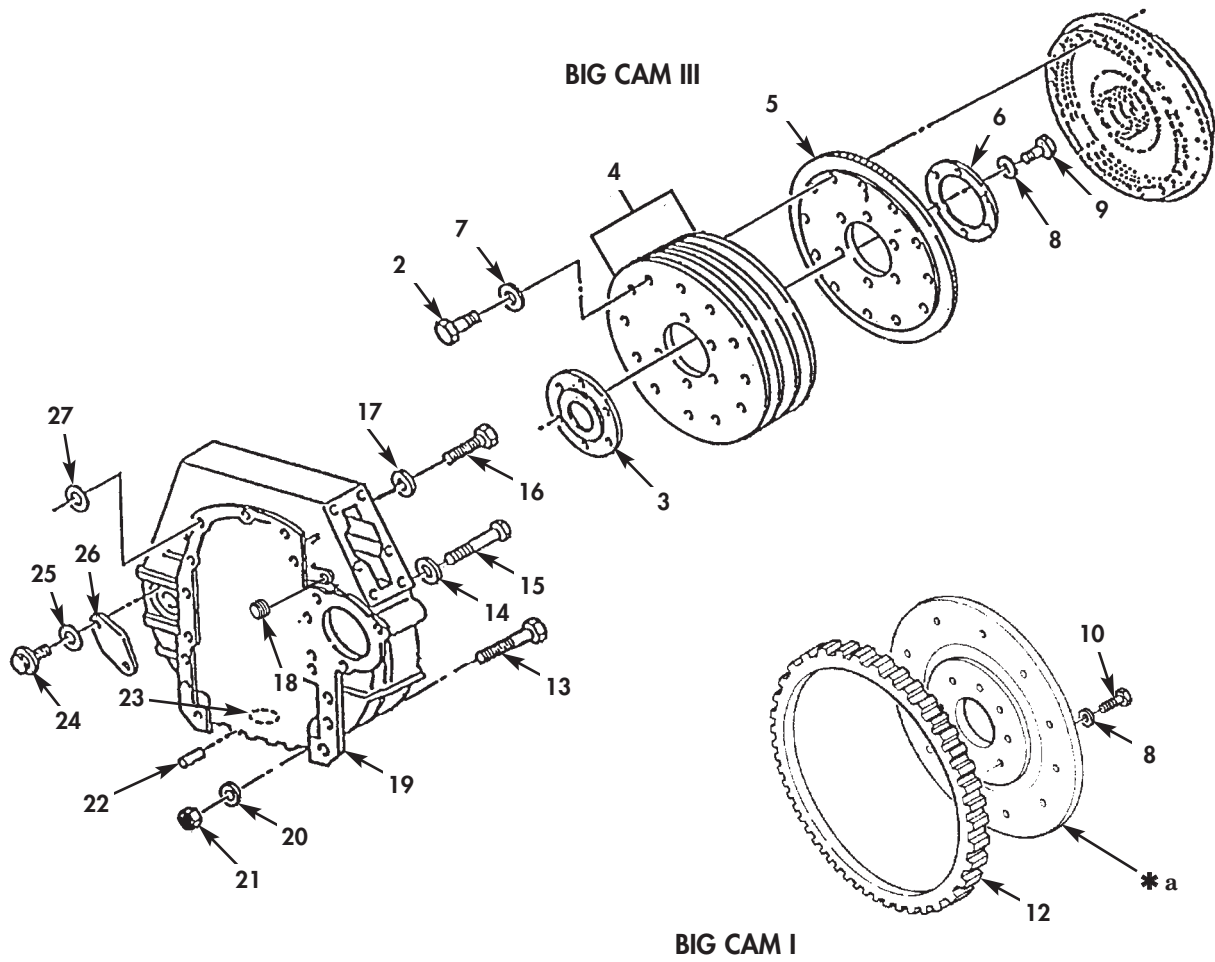


Figure 4. Crankshaft Assembly.

(1) ITEM NO	(2) SMR CODE	(3) NSN	(4) CAGEC	(5) PART NUMBER	(6) DESCRIPTION AND USABLE ON CODE(UOC)	(7) QTY
GROUP 0102 CRANKSHAFT						
FIG. 4 CRANKSHAFT ASSEMBLY						
1	PAFZZ	5330-00-361-2955	15434	3067616	GASKET PART OF KIT P/N 3801235.....	1
2	PAHZZ	2990-01-120-2883	15434	216165	COVER,REAR BIG CAM I.....	1
2	PAFZZ	2815-01-146-5925	15434	209919	COVER,TIMING GEAR,I BIG CAM III...	1
3	PAFZZ	5305-01-130-6100	15434	3010594	SCREW,CAP,HEXAGON H WITH CAPTIVE	8
					WASHER, 3/8-24 X 1.500.....	
4	PAFZZ	5330-00-005-0858	01212	M39807	SEAL REAR OIL PART OF KIT	1
					P/N 3801235.....	
5	PCHZZ	5331-00-420-9624	15434	137075	O-RING REAR COVER BIG CAM I.....	1
6	PAHZZ	3120-01-145-9132	15434	3801263	BEARING HALF SET,SL 0.030 UNDERSIZE	1
6	PAHZZ	3120-01-193-7083	01212	5116M40	BEARING SET,SLEEVE 0.040 UNDERSIZE.	1
6	PAHZZ	3120-01-144-8882	15434	3801262	BEARING HALF SET,SL 0.020 UNDERSIZE	1
6	PAHZZ	3120-01-132-9339	15434	3801260	BEARING SET,SLEEVE STANDARD BIG CAM	1
					III.....	
6	PAHZZ	3120-01-143-9547	15434	3801261	BEARING HALF SET,SL 0.010 UNDERSIZE	1
7	PAHZZ	2815-01-303-4224	15434	3608833	CRANKSHAFT,ENGINE.....	1
8	PAHZZ	3120-01-214-7779	15434	3019218	BEARING,WASHER,THRU STANDARD..... V	
8	XDHZZ		15434	157281	BEARING,WASHER,THRU 0.010 OVERSIZE. V	
8	XDHZZ		15434	157282	BEARING,WASHER,THRU..... V	
9	PAHZZ	5315-01-058-4551	15434	202903	PIN STRAIGHT HEXAGO 0.219 X 0.5475-	2
					0.5775.....	
10	PAHZZ	5365-00-428-6201	15434	60575	SPACER,RING.....	7
11	PAHZZ	5330-01-240-1619	15434	3020183	SEAL,PLAIN ENCASED PART OF KIT	1
					P/N 3801235.....	
12	PAFZZ	3020-01-077-4411	15434	211918	PULLEY,GROOVE.....	1
13	PAFZZ	2815-01-079-1632	15434	21732300	DAMPENER,VIBRATION,.....	1
14	PAFZZ	5305-00-795-9336	15434	204165	SCREW,CAP 1-5/8 LONG.....	6
15	PAFZZ	5310-00-081-8500	15434	127316	WASHER,RECESSED.....	6
16	PAHZZ	3020-01-077-2229	15434	215965	GEAR,HELICAL BIG CAM I.....	1
16	PAHZZ	3020-01-146-0107	15434	3014614	GEAR,HELICAL BIG CAM III.....	1
17	PAFZZ	5315-01-079-6740	15434	210179	KEY,MACHINE GEAR TO CRANKSHAFT.....	1

END OF FIGURE

1	2 thru 6
11	12



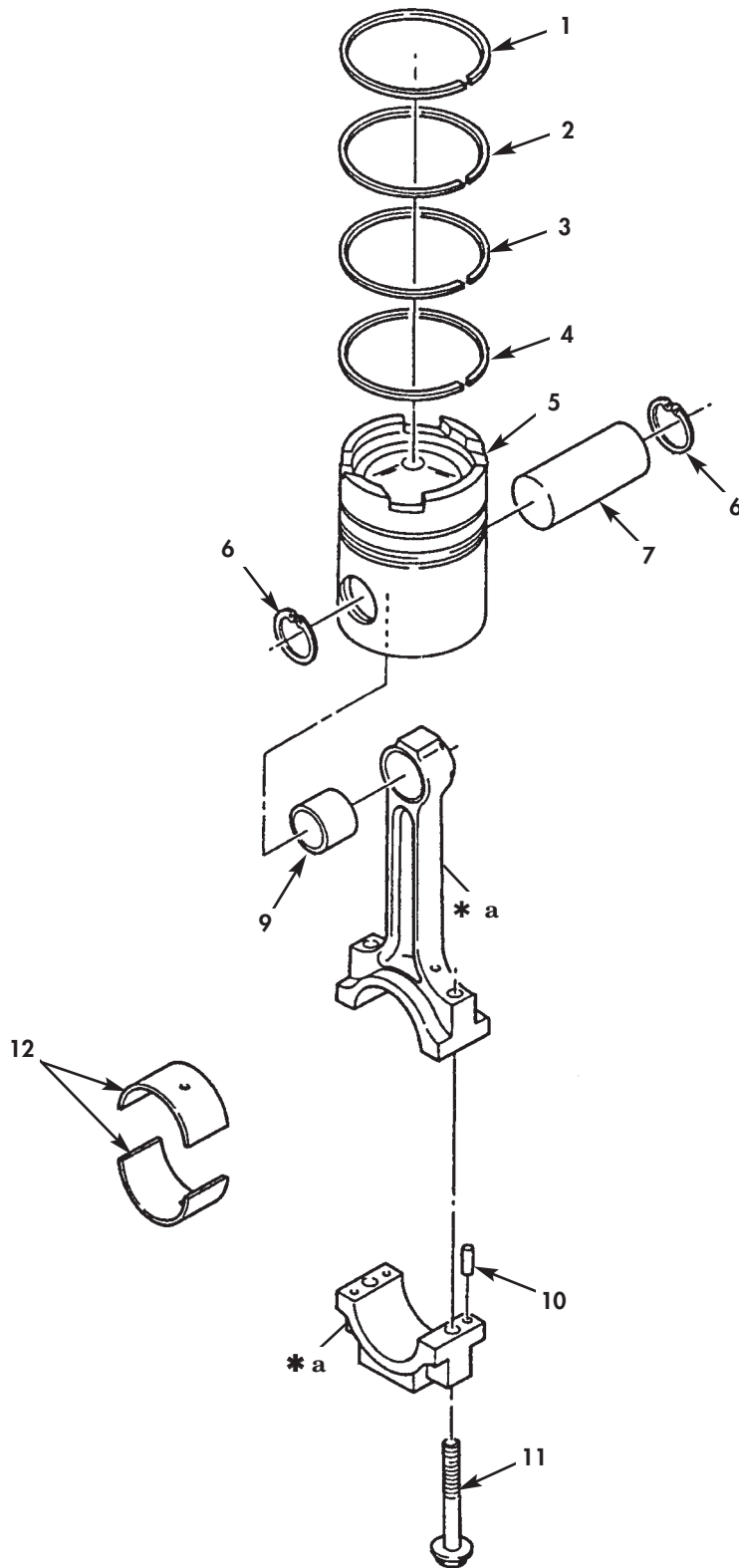
* a PART OF ITEM 11

Figure 5. Flexdisk, Ring Gear, and Housing.

(1) ITEM NO	(2) SMR CODE	(3) NSN	(4) CAGEC	(5) PART NUMBER	(6) DESCRIPTION AND USABLE ON CODE(UOC)	(7) QTY
GROUP 0103 FLYWHEEL ASSEMBLY						
FIG. 5 FLEXDISK, RING, GEAR AND HOUSING						
1	XDFZZ		15434	3031751	DISC, FLEX ASSEMBLY USE ONLY FOR INTERFACING BIG CAM III ENG	1
2	PAFZZ	5305-00-269-3240	80204	B1821BH038F150N	W/ALLISON HT-750 CRD TRANSMISSION... .SCREW, CAP, HEXAGON H 3/8-24 X 1.50	12
3	PBFZZ	3040-01-146-0028	15434	3031752	BIG CAM III..... .PLATE, RETAINING, SHA BIG CAM III...	1
4	XDFZZ		15434	3031750	.DISKS, FLEXPLATE USE ONLY FOR INTERFACING BIG CAM III ENG	1
5	PBFZZ	2815-01-146-0102	15434	3031749	W/ALLISON HT-750 CRD TRANSMISSION... .FLYWHEEL, ENGINE BIG CAM III.....	1
6	PBFZZ	3120-01-147-8118	15434	3031753	.BEARING, WASHER, THRU BIG CAM III...	1
7	PAFZZ	5310-00-080-6004	96906	MS27183-14	WASHER, FLAT 3/8.....	12
8	PAFZZ	5310-00-134-4171	15434	200861	WASHER, FLAT.....	12
9	PAFZZ	5305-01-112-9698	15434	180175	SCREW, CAP, HEXAGON H 1.44 LONG BIG CAM III.....	6
10	PAFZZ	5305-00-795-9336	15434	204165	SCREW, CAP BIG CAM I.....	6
11	PAFFF	2815-01-085-1881	15434	3021660	FLYWHEEL, ENGINE BIG CAM I.....	1
12	PAFZZ	3020-00-528-5053	15434	4797	.GEAR, SPUR BIG CAM I.....	1
13	PAFZZ	5305-00-091-4009	15434	106289	SCREW, CAP, HEXAGON H FLYWHEEL HS'G TO CRANKCASE BIG CAM I.....	2
14	PAFZZ	5310-00-081-8500	15434	127316	WASHER, RECESSED 0.630-0.650 X 1.185-1.195.....	9
15	PAFZZ	5305-01-145-8380	15434	S-189-B	SCREW, CAP, HEXAGON H.....	9
16	PAFZZ	5305-01-114-6386	15434	3012483	SCREW, CAP, HEXAGON H 1/2-13 X 2.00 FLYWHEEL HS'G TO BLOCK BIG CAM I....	4
17	PAFZZ	5310-00-134-4168	15434	S601	WASHER, FLAT FLYWHEEL HS'G TO BLOCK BIG CAM I.....	1
18	PBFZZ	4730-01-214-7081	15434	3008469	PLUG, PIPE 3/4 NPT FLYWHEEL HS'G MOUNTED BIG CAM I.....	1
19	PAFZZ	2815-01-160-5820	15434	3016637	HOUSING, FLYWHEEL BIG CAM I.....	1
19	PFFZZ	2815-01-141-0845	15434	3036005	HOUSING, FLYWHEEL BIG CAM III.....	1
20	PAFZZ	5310-00-584-5272	96906	MS35338-48	WASHER, LOCK 3/8 FLYWHEEL HS'G TO BLOCK BIG CAM I.....	2
21	PAFZZ	5310-00-469-3998	15434	S200	NUT, PLAIN, HEXAGON FLYWHEEL HS'G TO BLOCK BIG CAM I.....	2
22	PAFZZ	5315-00-014-1284	24617	141284	PIN, STRAIGHT, HEADLE FLYWHEEL HS'G MOUNTING.....	2
23	PAFZZ	4730-00-018-9566	15434	S911B	PLUG, PIPE FLYWHEEL HS'G MOUNTED, 1/4-NPT, BIG CAM I.....	1
24	PAFZZ	5305-01-147-4025	15434	3001646	SCREW, TAPPING FLYWHEEL INDEX HOLE COVER 1/4-20 X 5/8.....	2
25	PAFZZ	5330-01-082-6985	15434	3021735	GASKET FLYWHEEL INDEX HOLE COVER, BIG CAM I.....	2
26	PBFZZ	5340-01-122-8002	15434	70657	COVER, ACCESS FLYWHEEL INDEX HOLE...	1
27	PCFZZ	5330-00-404-2920	15434	172648	PACKING, PREFORMED.....	11

END OF FIGURE

8 —
9
thru
11



* a PART OF ITEM 8

Figure 6. Piston and Connecting Rod Assembly.

(1) ITEM NO	(2) SMR CODE	(3) NSN	(4) CAGEC	(5) PART NUMBER	(6) DESCRIPTION AND USABLE ON CODE(UOC)	(7) QTY
GROUP 0104 PISTONS, CONNECTING RODS						
FIG. 6 PISTON AND CONNECTING ROD ASSEMBLY						
1	KFHZZ		15434	3012331	RING,PISTON TOP PART OF KIT P/N 3801056.....	6
2	PFHZZ		15434	3804500	RING SET,PISTON BIG CAM III.....	3
2	PFHZZ	2815-01-241-6580	15434	301233200	RING,PISTON PART OF KIT P/N 3801056	6
3	PFHZZ	2815-01-241-6581	15434	214730	RING,PISTON PART OF KIT P/N 3801056	6
4	PFHZZ	2815-00-994-4429	15434	3064398	RING,PISTON PART OF KIT P/N 3801056	6
5	PAHZZ	2815-00-603-1381	15434	3804414	PISTON,INTERNAL COM BIG CAM I.....	6
5	KFHZZ		15434	3804416	PISTON BIG CAM III PART OF KIT P/N 3801058.....	6
6	PAHZZ	5325-01-241-4318	15434	175755	.RING,RETAINING PISTON PIN (OLD) BIG CAM I.....	12
6	PBHZZ	5325-00-804-2784	96906	MS16625-1200	.RING,RETAINING PART OF KIT P/N 3801058.....	12
7	PFHZZ	2815-00-480-4347	15434	191970	PIN,PISTON PART OF KIT P/N 3801058.	6
8	PAHZZ	2815-01-086-4508	15434	3013930	CONNECTING ROD,PIST ASSEMBLY.....	6
9	PAHZZ	5365-00-132-0273	15434	187420	.BUSHING,PISTON PIN.....	1
10	PBHZZ	2815-01-124-0232	15434	70550	.PIN,PISTON CONNECTING ROD 5/16 X 1/2.....	2
11	PAHZZ	5306-01-079-7027	15434	219153	.BOLT,MACHINE.....	2
12	PAHZZ	3120-01-155-8707	15434	214953	BEARING,SLEEVE .030 UNDERSIZE.....	12
12	PAHZZ	3120-01-155-4442	15434	214951	BEARING,SLEEVE 0.010 UNDERSIZE.....	12
12	PAHZZ	3120-01-157-3316	15434	214952	BEARING,SLEEVE 0.020 UNDERSIZE.....	12
12	PAHZZ	3120-01-087-3004	01212	3725CP	BEARING STANDARD.....	12

END OF FIGURE

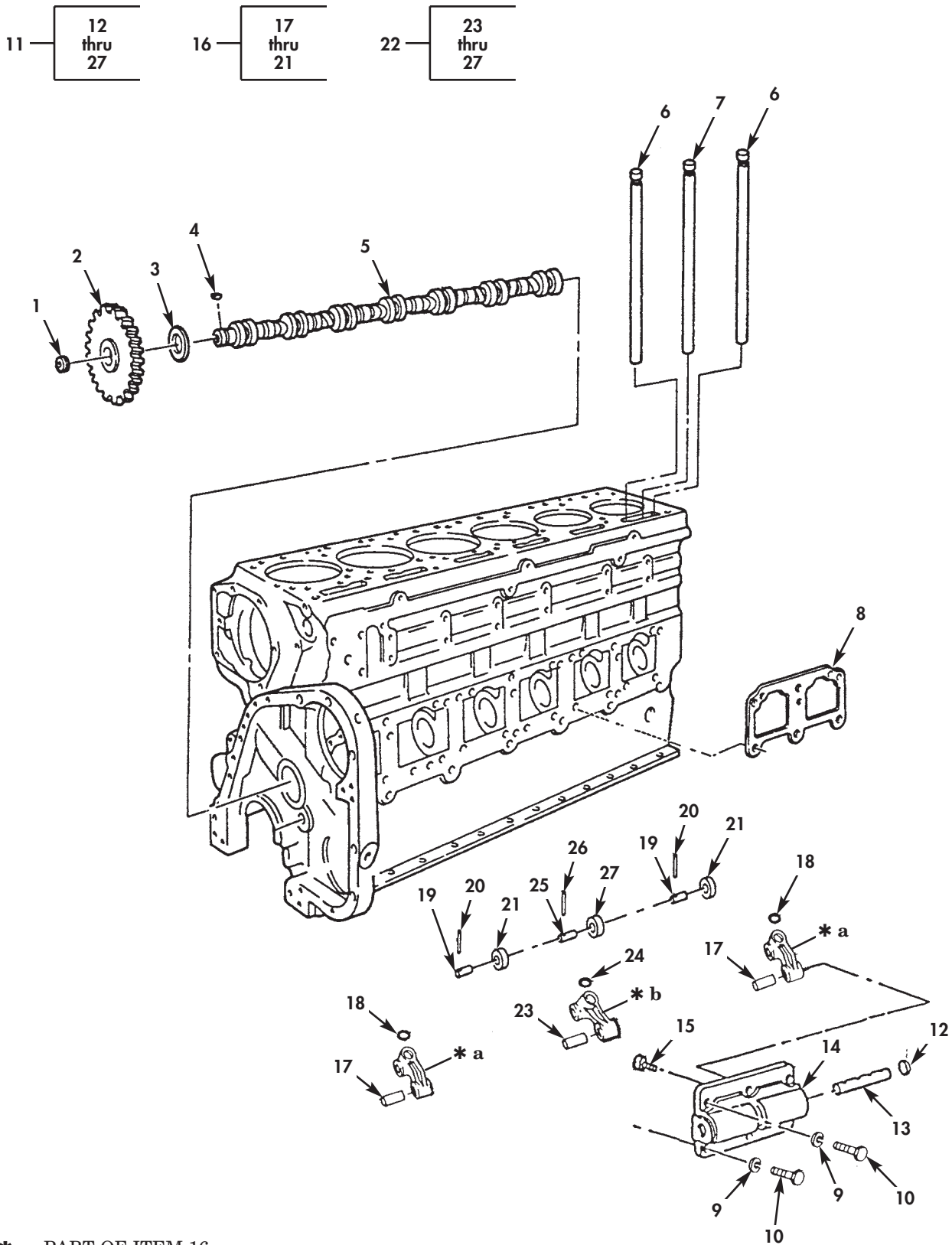
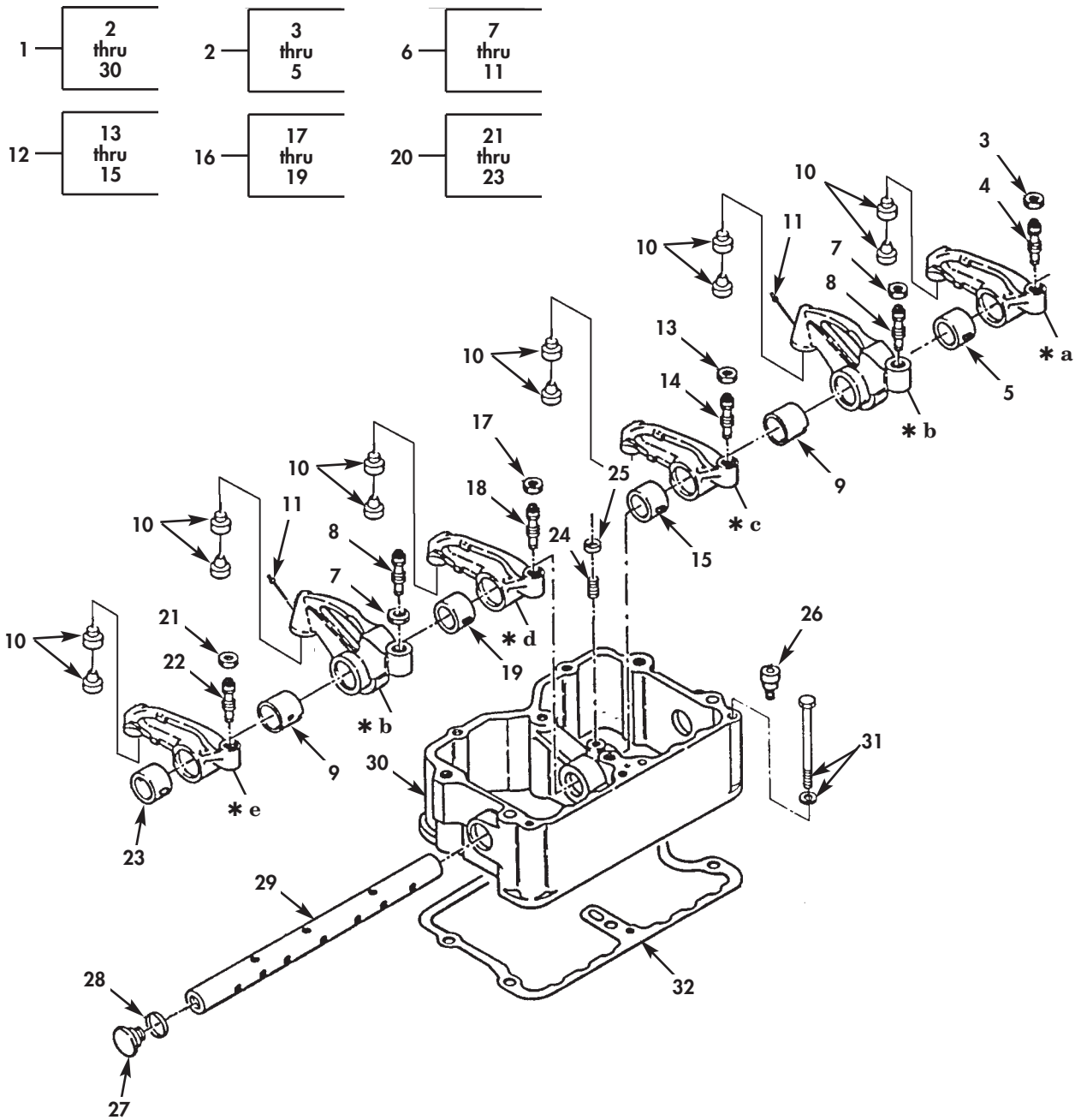


Figure 7. Camshaft Assembly and Followers.

(1) ITEM NO	(2) SMR CODE	(3) NSN	(4) CAGEC	(5) PART NUMBER	(6) DESCRIPTION AND USABLE ON CODE(UOC)	(7) QTY
GROUP 0105 VALVES,CAMSHAFTS AND FOLLOWERS						
FIG. 7 CAMSHAFT ASSEMBLY AND FOLLOWERS						
1	PAHZZ	5340-00-404-2944	15434	68193	PLUG,VENT CAMSHAFT ORIFICE, SPECIAL	1
2	PAHZZ	3020-01-145-8568	15434	3002901	GEAR,HELICAL BIG CAM III	1
3	PAHZZ	3120-01-079-8194	15434	215233	BEARING,WASHER,THRU BIG CAM I	1
4	PAHZZ	5315-01-145-6080	15434	3021596	KEY,WOODRUFF GEAR TO CAMSHAFT,BIG CAM III	1
5	PAHZZ	2815-01-079-3380	15434	3801047	CAMSHAFT,ENGINE BIG CAM I	1
5	PAHZZ	2815-01-146-1049	15434	3049024	CAMSHAFT,ENGINE BIG CAM III	1
6	XDHZZ		15434	217929	PUSH ROD,ENGINE POP INTAKE AND EXHAUST, CAM FOLLOWER ASSY, BIG CAM I	12
6	PAFZZ	2815-01-146-1041	15434	3012462	PUSH ROD,ENGINE POP INTAKE AND EXHAUST, CAM FOLLOWER ASSY, BIG CAM III	12
7	PAFZZ	2815-01-085-2615	15434	3032681	PUSH ROD,ENGINE POP	6
8	PCHZZ	5330-01-145-3983	15434	3074401	GASKET CAM FOLLOWER HOUSING,STANDARD,BIG CAM III PART OF KIT P/N 3801235	3
8	PCHZZ	5330-01-146-9775	15434	3074402	GASKET CAM FOLLOWER HOUSING, 0.014-0.020 PART OF KIT P/N 3801235	3
8	PCHZZ	5330-01-145-3984	15434	3074404	GASKET CAM FOLLOWER HOUSING, 0.027-0.033, BIG CAM III PART OF KIT P/N 3801235	3
8	PFHZZ	5330-01-146-9928	15434	3074403	GASKET CAM FOLLOWER HOUSING, 0.020-0.024 PART OF KIT P/N 3801235	3
8	PAHZZ	5330-01-146-7172	15434	3074400	GASKET CAM FOLLOWER HOUSING,STANDARD,BIG CAM I PART OF KIT P/N 3018762	3
9	PAHZZ	5310-00-261-7340	15434	S604	WASHER,LOCK 3/8	18
10	PAHZZ	5305-00-546-6698	15434	S-129	SCREW,CAP,HEXAGON H	18
11	PFHZZ	2815-01-166-3415	15434	3066796	HOUSING ASSEMBLY,CA	3
12	PAHZZ	5340-00-485-0945	15434	175831	.PLUG,EXPANSION 3/4 INCH	2
13	PAHZZ	3040-00-388-3126	15434	3065125	.SHAFT,STRAIGHT CAM FOLLOWER ASSEMBLY	2
14	PBHZZ	2815-01-146-7039	15434	3016887	.COVER,ENGINE POPPET CAM FOLLOWER .	1
15	PAHZZ	5305-00-339-1415	15434	69736	.SCREW,MACHINE SHAFT LOCKING, 5/16-18 UNC-2A	2
16	PAHZZ	2815-01-305-8530	15434	3036935	.ROCKER ARM,ENGINE P CAM FOLLOWER ASSY,INTAKE & EXHAUST	4
17	PFHZZ	3120-00-659-7808	15434	118378	..BEARING,SLEEVE CAM FOLLOWER ASSY,INTAKE & EXHAUST	4
18	PAHZZ	2815-01-048-6702	15434	213559	..SOCKET,CAM FOLLOWER INTAKE & EXHAUST	4
19	XBHZZ		15434	3002069	..PIN,STRAIGHT,HEADED CAM FOLLOWER ASSY,INTAKE & EXHAUST,BIG CAM I	4
19	PAHZZ	5315-01-210-0616	15434	3013331	..PIN,STRAIGHT,HEADED CAM FOLLOWER ASSY,INTAKE & EXHAUST,BIG CAM III ..	4
20	PAHZZ	5315-00-777-3544	15434	118939	..PIN,STRAIGHT,HEADLE CAM FOLLOWER ASSY,INTAKE & EXHAUST	4
21	PAHZZ	3120-01-212-4472	15434	3036933	..ROLLER,LINEAR-ROTAR CAM FOLLOWER ASSY,INTAKE & EXHAUST	4
22	PAHZZ	2910-01-086-9757	15434	3056569	.ROCKER ARM,ENGINE P CAM FOLLOWER ASSY,INJECTOR	2
23	PFHZZ	3120-00-791-1440	15434	118377	..BEARING,SLEEVE CAM FOLLOWER ASSY,INJECTOR	2

(1) Item NO	(2) SMR Code	(3) NSN	(4) CAGEC	(5) PART NUMBER	(6) DESCRIPTION AND USABLE ON CODE(UOC)	(7) Qty
24	PAHZZ	2815-00-505-5119	15434	107738	..SOCKET,CAM FOLLOWER INJECTOR	2
25	XBHZZ		15434	219107	..PIN,STRAIGHT,HEADED CAM FOLLOWER ASSY,INJECTOR	2
26	PAHZZ	5315-00-777-3544	15434	118939	..PIN,STRAIGHT,HEADLE CAM FOLLOWER ASSY,INJECTOR	2
27	PFHZZ	3120-01-079-5451	15434	3036934	..ROLLER,LINEAR-ROTAR CAM FOLLOWER ASSY,INJECTOR	2

END OF FIGURE



- * a PART OF ITEM 2
- * b PART OF ITEM 6
- * c PART OF ITEM 12
- * d PART OF ITEM 16
- * e PART OF ITEM 20

Figure 8. Rocker Arm Assembly.

(1) ITEM NO	(2) SMR CODE	(3) NSN	(4) CAGEC	(5) PART NUMBER	(6) DESCRIPTION AND USABLE ON CODE(UOC)	(7) QTY
GROUP 0105 VALVES, CAMSHAFTS AND TIMING SYSTEM						
FIG. 8 ROCKER ARM ASSEMBLY						
1	PAFFF	2815-01-085-2569	15434	3035961	HOUSING AND ROCKER ROCKER ARM ASSEMBLY.....	3
2	PAFZZ	2815-01-096-9198	15434	BM95161	.ROCKER ARM,ENGINE P EXHAUST.....	1
3	PAFZZ	5310-00-732-0560	96906	MS51968-14	..NUT,PLAIN,HEXAGON ROCKER ARM ADJUSTING SCREW,EXHAUST 1/2-20 UNF- 2B R/H.....	1
4	PAFZZ	5305-00-947-3437	15434	168306	..SETSCREW ROCKER ARM,EXH,HEADLESS W/SLOT 1/2-20X2.045 UNF-3A R/H.....	1
5	PAFZZ	3120-00-589-3537	15434	140330	..BUSHING,SLEEVE ROCKER ARM EXHAUST	1
6	PAFZZ	2815-00-005-7431	15434	AR-2308	.LEVER,INJECTOR,FUEL.....	2
7	PAFZZ	5310-00-732-0560	96906	MS51968-14	..NUT,PLAIN,HEXAGON ROCKER ARM ADJUSTING SCREW,INJECTOR 1/2-20 UNF- 2B R/H.....	1
8	PAFZZ	5305-00-947-3437	15434	168306	..SETSCREW ROCKER ARM,INJ,HEADLESS W/SLOT 1/2-20X2.045 UNF-3A R/H.....	2
9	PAFZZ	3120-01-079-5208	15434	218153	..BUSHING,SLEEVE ROCKER ARM INJECTOR.....	2
10	PAFZZ	5340-00-404-2940	15434	194037	..SEAT,BALL SOCKET ROCKER ARM INJECTOR.....	2
11	PAFZZ	5320-01-163-2277	15434	208084	..RIVET,BLIND ROCKER ARM INJECTOR..	2
12	PAFZZ	2815-00-195-5894	15434	BM95159	.ROCKER ARM,ENGINE P INTAKE.....	1
13	PAFZZ	5310-00-732-0560	96906	MS51968-14	..NUT,PLAIN,HEXAGON ROCKER ARM ADJUSTING SCREW,INTAKE 1/2-20 UNF-2B R/H.....	1
14	PAFZZ	5305-00-947-3437	15434	168306	..SETSCREW ROCKER ARM,INT,HEADLESS W/SLOT 1/2-20X2.045 UNF-3A R/H.....	1
15	PAFZZ	3120-00-589-3537	15434	140330	..BUSHING,SLEEVE ROCKER ARM INTAKE..	1
16	PAFZZ	2815-00-195-5897	15434	BM95160	.ROCKER ARM,ENGINE P INTAKE.....	1
17	PAFZZ	5310-00-732-0560	96906	MS51968-14	..NUT,PLAIN,HEXAGON ROCKER ARM ADJUSTING SCREW,INTAKE 1/2-20 UNF-2B R/H.....	1
18	PAFZZ	5305-00-947-3437	15434	168306	..SETSCREW ROCKER ARM,INT,HEADLESS W/SLOT 1/2-20X2.045 UNF-3A R/H.....	1
19	PAFZZ	3120-00-589-3537	15434	140330	..BUSHING,SLEEVE ROCKER ARM INTAKE..	1
20	PAFZZ	2815-00-851-7637	15434	BM95162	.ROCKER ARM,ENGINE P INTAKE.....	1
21	PAFZZ	5310-00-732-0560	96906	MS51968-14	..NUT,PLAIN,HEXAGON ROCKER ARM ADJUSTING SCREW,EXHAUST 1/2-20 UNF- 2B R/H.....	1
22	PAFZZ	5305-00-947-3437	15434	168306	..SETSCREW ROCKER ARM,EXH,HEADLESS W/SLOT 1/2-20X2.045 UNF-3A R/H.....	1
23	PAFZZ	3120-00-589-3537	15434	140330	..BUSHING,SLEEVE ROCKER ARM EXHUAUST	1
24	PAFZZ	5305-00-297-4022	15434	168319	.SETSCREW ROCKER ARM SHAFT.....	1
25	PAFZZ	5330-01-145-6083	75078	010180	.PACKING,PREFORMED.....	1
26	PAFZZ	5340-01-163-7118	15434	216296	.PLUG,VENT ROCKER ARM HOUSING.....	1
27	PAFZZ	4730-01-124-0293	15434	218736	.PLUG,QUICK DISCONN ROCKER ARM SHAFT.....	2
28	PCFZZ	5331-00-984-3756	19207	7374401	.O-RING ROCKER ARM SHAFT.....	2
29	PAFZZ	3040-01-079-1799	15434	3801433	.SHAFT,STRAIGHT ROCKER ARM HOUSING..	1
30	PBFZZ	2815-01-210-6947	15434	3036285	.HOUSING,ROCKER ARM.....	1
31	PAFZZ	5305-01-129-6901	15434	3010589	SCREW,ASSEMBLED WAS ROCKER ARM HOUSING ASSY 1/2-13 X 4.750 UNC-2A..	18
32	PFFZZ	5330-00-861-8592	15434	3017750	GASKET ROCKER ARM HOUSING ASSEMBLY PART OF KIT P/N 4024958 PART OF KIT P/N 3804280.....	3
END OF FIGURE						

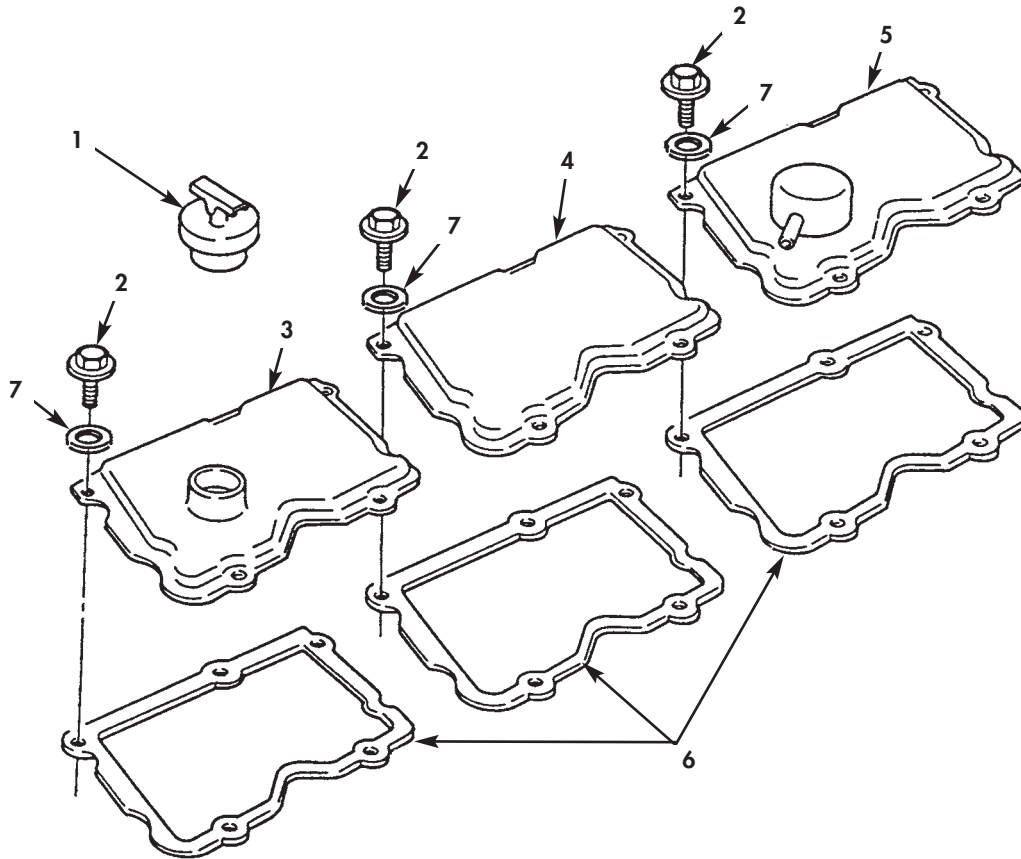


Figure 9. Rocker Cover.

(1) ITEM NO	(2) SMR CODE	(3) NSN	(4) CAGEC	(5) PART NUMBER	(6) DESCRIPTION AND USABLE ON CODE(UOC)	(7) QTY
GROUP 0105 VALVES, CAMSHAFTS AND TIMING SYSTEM						
FIG. 9 ROCKER COVER						
1	PAOZZ	2590-00-590-7378	15434	101322	CAP,FILLER OPENING.....	1
2	PAOZZ	5305-01-118-8826	15434	3006182	SCREW,CAP,HEXAGON H CAPTIVE WASHER, 3/8-16UNC-2A X 0.845-0.875.....	15
3	PBOZZ	2815-01-164-6103	15434	3006349	COVER,ENGINE POPPET ROCKER AND RETARDER,BIG CAM I.....	1
3	PAOZZ	2815-01-159-1737	15434	3006187	COVER,ENGINE POPPET BIG CAM III....	1
4	PAOZZ	2815-01-142-1732	15434	3006183	COVER,ENGINE POPPET.....	1
5	PAOZZ	2815-01-146-1024	15434	3006358	COVER,ENGINE POPPET.....	1
6	PAOZZ	5330-01-285-4827	15434	3054841	GASKET ROCKER COVER,BIG CAM III....	3
7	PBOZZ	5365-01-241-3903	15434	64709	SPACER,SLEEVE BIG CAM I.....	15
END OF FIGURE						

1 — 2 thru 29

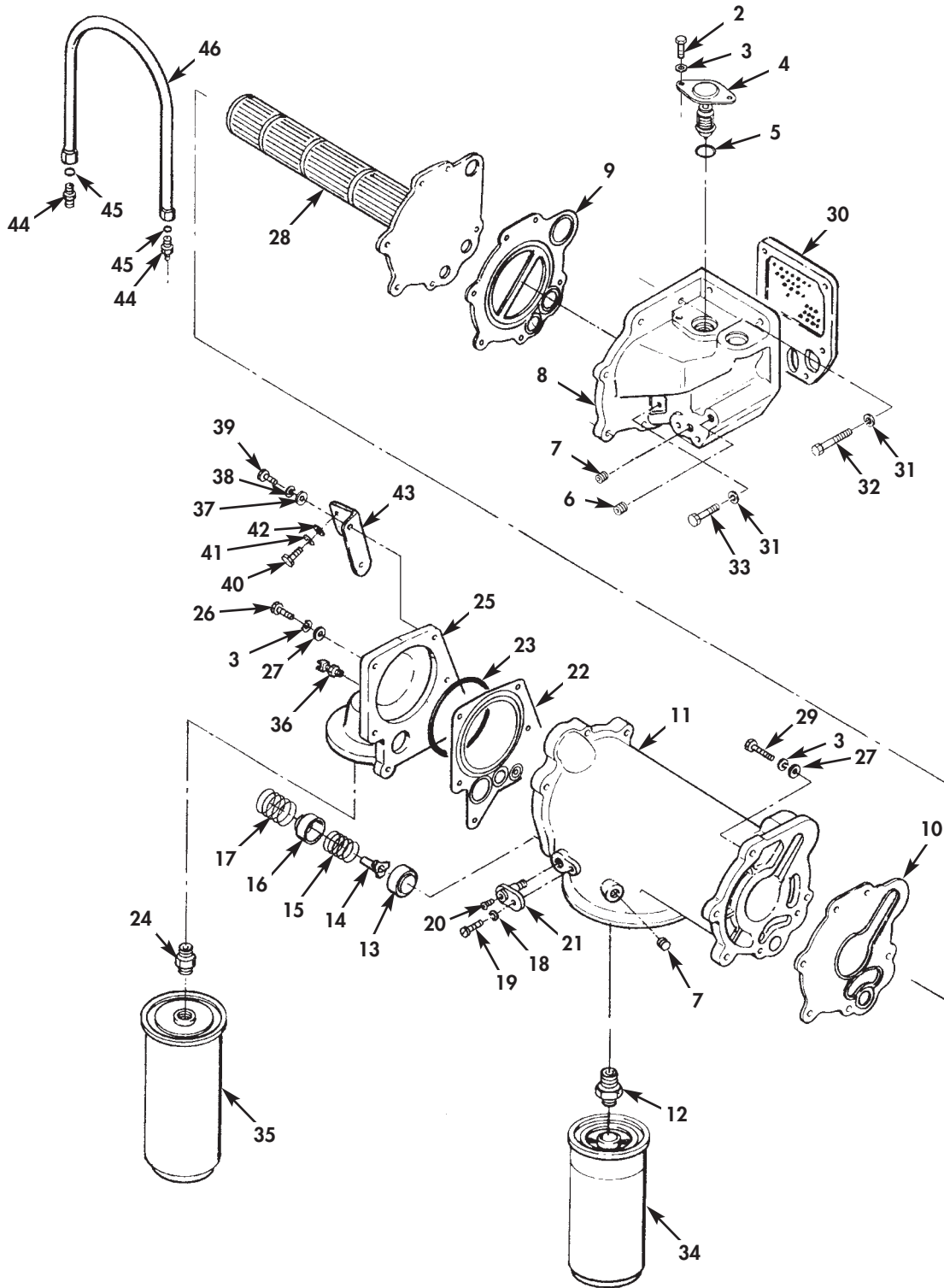


Figure 10. Oil Cooler and Filter, Big Cam III.

(1) ITEM NO	(2) SMR CODE	(3) NSN	(4) CAGEC	(5) PART NUMBER	(6) DESCRIPTION AND USABLE ON CODE(UOC)	(7) QTY
GROUP 0106 CRANKCASE, BLOCK AND CYLINDER HEAD						
FIG. 10 OIL COOLER AND FILTER,BIG CAM III						
1	PAFHH	2930-01-141-0918	15434	3032307	COOLER,LUBRICATING OIL.....	1
2	PAHZZ	5305-00-091-4006	15434	137795	.SCREW,CAP,HEXAGON H 3/8-16X5/8....	2
3	PAHZZ	5310-00-261-7340	15434	S-604	.WASHER,LOCK.....	11
4	PAHZZ	2930-01-145-9537	15434	3023512	.VALVE,BYPASS.....	1
5	PCHZZ	5331-01-145-6085	15434	3045979	.O-RING PART OF KIT P/N 3801235....	1
6	PFHZZ	4730-00-042-8988	7X677	117244	.PLUG,PIPE 1/4.....	1
7	PAHZZ	4730-00-057-5555	15434	S-908	.PLUG,PIPE 3/8.....	2
8	PBHZZ	2930-01-145-9538	15434	302746000	.SUPPORT,OIL COOLER.....	1
9	PFHZZ	5330-01-145-6911	15434	3047464	.GASKET OIL COOLER CORE PART OF KIT P/N 3801235.....	1
10	PAHZZ	5330-01-145-6910	15434	3047465	.GASKET PART OF KIT P/N 3801235....	1
11	XAHZZ		15434	3018690	.HOUSING,OIL COOLER.....	1
12	PAOZZ	2940-01-145-9398	15434	303457800	.ADAPTER,FILTER HEAD.....	1
13	PAHZZ	2940-01-145-9399	15434	3030804	.PISTON,BYPASS VALVE PRESSURE, SENSING.....	1
14	PAHZZ	2940-01-145-9400	15434	3030806	.PLUNGER,BYPASS VALV.....	1
15	PAHZZ	5360-01-145-3974	15434	3030803	.SPRING,HELICAL,COMP COMPRESSION...	1
16	PAHZZ	4820-01-210-3573	15434	303080500	.PISTON,VALVE.....	1
17	PAHZZ	5360-01-145-3975	15434	3039296	.SPRING,HELICAL,COMP.....	1
18	PAOZZ	5331-01-145-6086	15434	3030808	.O-RING PART OF KIT P/N 3801235....	1
19	PAOZZ	5305-01-144-6232	15434	3031005	.SCREW,CAP,HEXAGON H.....	1
20	PFOZZ	5305-01-508-7097	0B8S3	101996	.SCREW,MACHINE 18-32 X 3/8.....	1
21	PAOZZ	5930-01-177-0346	15434	3035028	.SWITCH,PRESSURE.....	1
22	PCHZZ	5330-01-145-6909	15434	3069014	.GASKET PART OF KIT P/N 3801235....	1
23	PFHZZ	5331-01-154-4316	15434	3018695	.O-RING PART OF KIT P/N 3801235....	1
24	PAOZZ	4330-01-146-1082	15434	3021656	.ADAPTER,FILTER HEAD.....	1
25	PAHZZ	2940-01-146-5846	15434	303724200	.HEAD,FLUID FILTER.....	1
26	PAHZZ	5305-00-725-2317	80204	B1821BH038C150N	.SCREW,CAP,HEXAGON H 3/8-16 X 1.50.	3
27	PAHZZ	5310-00-080-6004	96906	MS27183-14	.WASHER,FLAT 13/32.....	9
28	PAHZZ	2930-01-146-1081	15434	3412285	.CORE,OIL COOLER.....	1
29	PAHZZ	5305-00-782-9489	80204	B1821BH038C200N	.SCREW,CAP,HEXAGON H 3/8-16 X 2.00.	6
30	PFZZ	5330-01-079-6514	15434	3008017	GASKET PART OF KIT P/N 3801235....	1
31	PAHZZ	5310-00-261-7340	15434	S-604	WASHER,LOCK.....	6
32	PAFZZ	5305-00-068-0511	80204	B1821BH038C125N	SCREW,CAP,HEXAGON H 3/8-16 X 1.25..	3
33	PAFZZ	5305-00-404-1388	15434	S-199-B	SCREW,CAP,HEXAGON H 3/8-16 X 3.75..	3
34	PAOZZ	2940-01-019-4513	15434	299670	FILTER ELEMENT,FLUI SPIN ON.....	1
35	PAOZZ	2940-01-145-9455	15434	3313283	FILTER ELEMENT,FLUI SPIN ON.....	1
36	PAOZZ	4820-00-276-9041	15434	107947	COCK,DRAIN.....	1
37	PAHZZ	5310-01-103-6042	24617	120392	WASHER,FLAT.....	2
38	PAFZZ	5310-00-637-9541	96906	MS35338-46	WASHER,LOCK 3/8.....	2
39	PAFZZ	5305-00-638-8920	80204	B1821BH038C225N	SCREW,CAP,HEXAGON H 3/8-16 X 2.25..	2
40	PAFZZ	5305-00-071-2517	80204	B1821BH025C350N	SCREW,CAP,HEXAGON H 1/4-20 X 3.50..	2
41	PAFZZ	5310-00-159-6209	96906	MS122032	WASHER,LOCK 1/4.....	2
42	PAFZZ	5310-00-562-6560	15434	S-631	WASHER,FLAT 9/32.....	2
43	PBFZZ	5340-01-145-0772	15434	3018697	BRACKET,ANGLE.....	1
44	PFOZZ	4730-00-365-2690	15434	S-1002-A	ADAPTER,STRAIGHT,TU.....	2
45	PAOZZ	5330-01-222-2306	15434	3034579	SEAL.....	2
46	XBOZZ		15434	3035595	TUBE ASSEMBLY,METAL.....	1

END OF FIGURE

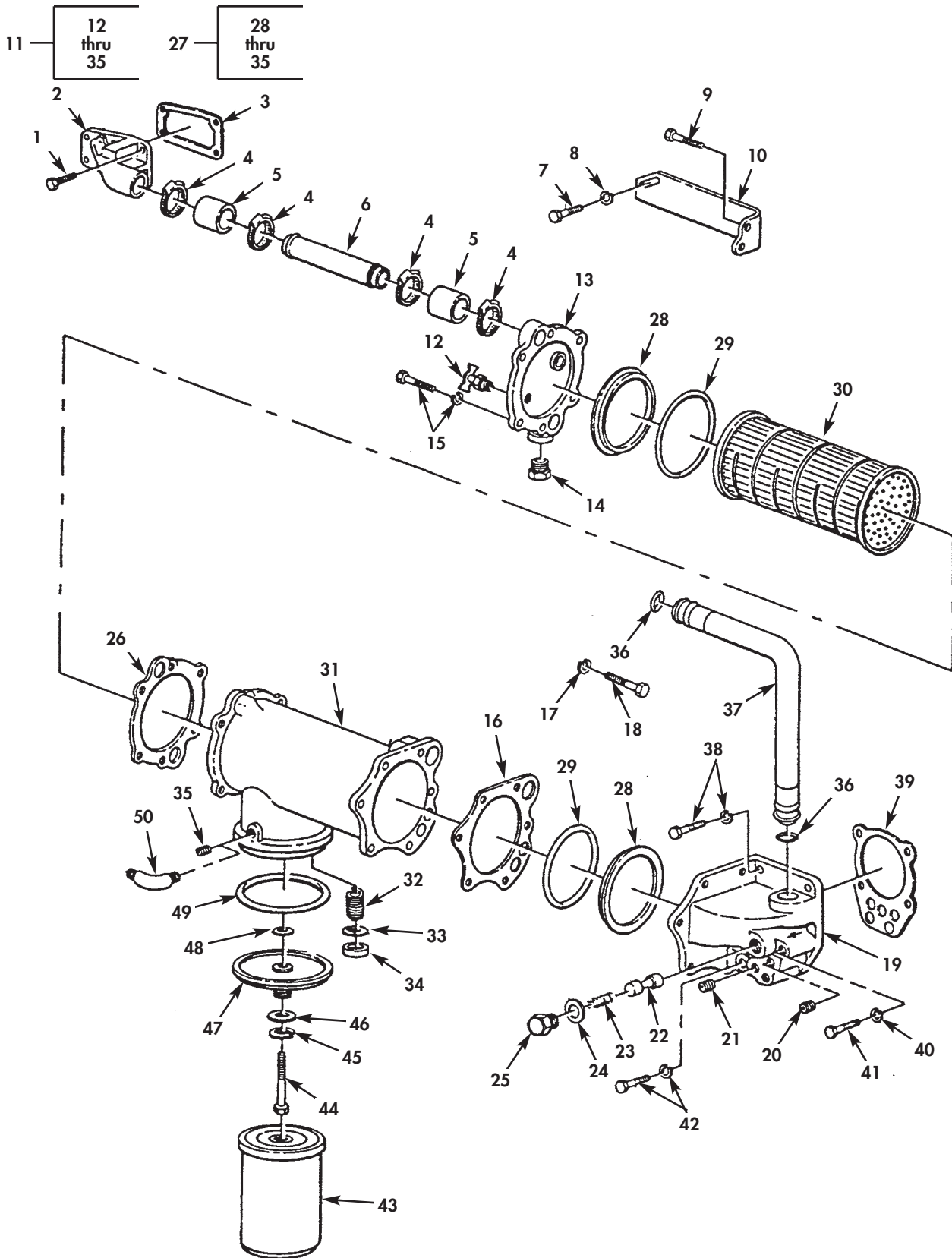


Figure 11. Oil Cooler and Filter, Big Cam I.

(1) ITEM NO	(2) SMR CODE	(3) NSN	(4) CAGEC	(5) PART NUMBER	(6) DESCRIPTION AND USABLE ON CODE(UOC)	(7) QTY
GROUP 0106 ENGINE LUBRICATING SYSTEM						
FIG. 11 OIL COOLER AND FILTER, BIG CAM I						
1	PAFZZ	5305-01-135-5344	15434	3011342	SCREW.....	6
2	PAFZZ	4730-01-241-7258	15434	301123300	ELBOW,FLANGE TO HOS.....	1
3	PAFZZ	5330-00-537-2382	15434	70089-1	GASKET PART OF KIT P/N 3018762.....	2
4	PAFZZ	4730-01-163-7192	0B8SE	3008690	CLAMP,HOSE.....	4
5	PCFZZ	4720-01-085-2571	15434	3031560	HOSE,NONMETALLIC.....	2
6	PFFZZ	4710-01-181-1956	15434	3000907	TUBE,WATER TRANSFER.....	1
7	PBFZZ	5305-01-203-6444	15434	S145	SCREW,CAP,HEXAGON H 1/2-13 X 1.25..	1
8	PAFZZ	5310-00-584-5272	96906	MS35338-48	WASHER,LOCK 3/8.....	1
9	PBFZZ	5305-01-085-8197	15434	3010595	SCREW,MACHINE 3/8-16 X 1.00.....	2
10	PAFZZ	5340-01-242-0805	15434	210966	BRACKET,ANGLE.....	1
11	PAFHH	2520-01-090-4473	15434	3003814	COOLER ASSEMBLY,OIL.....	1
12	PAOZZ	4820-00-276-9041	15434	107947	COCK,DRAIN.....	1
13	PAHZZ	2930-01-231-1661	15434	217315	.COVER,COOLER.....	1
14	PFFZZ	5365-00-708-3434	15434	110907	.PLUG,MACHINE THREAD 1"-18 X1-1/16 UNS R/H EXTERNAL.....	1
15	PAFZZ	5305-01-088-6019	15434	3010596	SCREW,ASSEMBLED WAS HEXAGON HEAD WITH CAPTIVE WASHER, 3/8-16 X 3 3/4. .GASKET PART OF KIT P/N 3018762....	5
16	PAFZZ	5330-01-046-3144	15434	3010030	.WASHER,LOCK 3/8.....	1
17	PAFZZ	5310-00-261-7340	96906	MS35338-8	.SCREW,CAP,HEXAGON H.....	1
18	PAFZZ	5305-00-177-5552	15434	S126	.COVER,ACCESS.....	1
19	PFHZZ	5340-01-342-3610	15434	210967	.PLUG,EXPANSION.....	1
20	XBHZZ		15434	142110	.PLUG,PIPE 1/4 EXTERNAL R.H. NPT RECESSED HEX HEAD.....	1
21	PFHZZ	4730-00-042-8988	7X677	117244	.PLUNGER,OIL PUMP RE.....	1
22	PAHZZ	2815-00-791-1453	15434	127558	.SPRING,HELICAL,COMP.....	1
23	PAHZZ	5360-00-664-5343	15434	68274	.SPACER,RING PART OF KIT P/N 3018762.....	1
24	PCHZZ	5365-00-197-9327	15434	67946	.PLUG,TUBE FITTING,T.....	1
25	PBFZZ	4730-01-309-3321	15434	3060882	.GASKET PART OF KIT P/N 3018762....	1
26	PAFZZ	5330-01-046-1991	15434	218245	.COOLER,LUBRICATING.....	1
27	PBFHZ	2930-01-165-4581	15434	AR-09999	.RING,RETAINING.....	2
28	PAFZZ	5325-01-139-6738	15434	3006745	..PACKING,PREFORMED PART OF KIT P/N 3018762.....	2
29	PCHZZ	5330-01-086-6197	15434	3007713	..CORE,RADIATOR.....	1
30	PAFZZ	2930-01-065-7113	15434	3021581	..HOUSING,OIL COOLER.....	1
31	PFHZZ	2815-01-241-4719	15434	21091500	..SPRING,HELICAL,COMP.....	1
32	PFHZZ	5360-01-200-0323	15434	202128	..DISC,BYPASS.....	1
33	XAHZZ		15434	210707	..SEAT,BYPASS FILTER.....	1
34	PAHZZ	2940-01-146-1995	15434	179063	..PLUG,PIPE.....	1
35	PAHZZ	4730-00-018-9566	15434	S911B	O-RING PART OF KIT P/N 3804280....	2
36	PCOZZ	5331-01-077-5228	15434	212161	TUBE,BENT,METALLIC.....	1
37	PAOZZ	4710-01-146-3086	15434	3024666	SCREW,ASSEMBLED WAS 3/8-16 X 1 1/4.	2
38	PAFZZ	5305-01-088-6019	15434	3010596	GASKET PART OF KIT P/N 3018762.....	1
39	PAFZZ	5330-01-079-6514	15434	3008017	WASHER,LOCK.....	2
40	PAFZZ	5310-00-261-7340	96906	MS35338-8	SCREW,CAP,HEXAGON H 3/8-16 X 4.75..	2
41	PAFZZ	5305-00-165-8157	72582	450517	SCREW WITH LOCKWASHER, 3/8-16 X 3.75.....	2
42	PAFZZ	5305-01-086-7036	15434	3010597	FILTER ELEMENT,FLUI.....	1
43	PAOZZ	2940-01-019-4513	15434	299670	SCREW,CAP,HEX HEAD.....	1
44	XBHZZ		15434	S152B	WASHER,LOCK 5/8.....	1
45	PFHZZ	5310-00-820-6653	15434	S627	WASHER,FLAT 5/8.....	1
46	PAFZZ	5310-00-134-4171	15434	200861	HEAD,FLUID FILTER.....	1
47	PAOZZ	2940-01-065-7076	0B8S3	3300908	GASKET PART OF KIT P/N 3018762....	1
48	PAOZZ	5330-01-164-0944	33457	3308958	PACKING,PREFORMED PART OF KIT P/N 3018762.....	1
49	PAFZZ	5330-00-132-0248	15434	173368	ELBOW,PIPE TO TUBE.....	1
50	PAFZZ	4730-00-254-6227	79470	49X6X2		

END OF FIGURE

2 — 3
thru
12

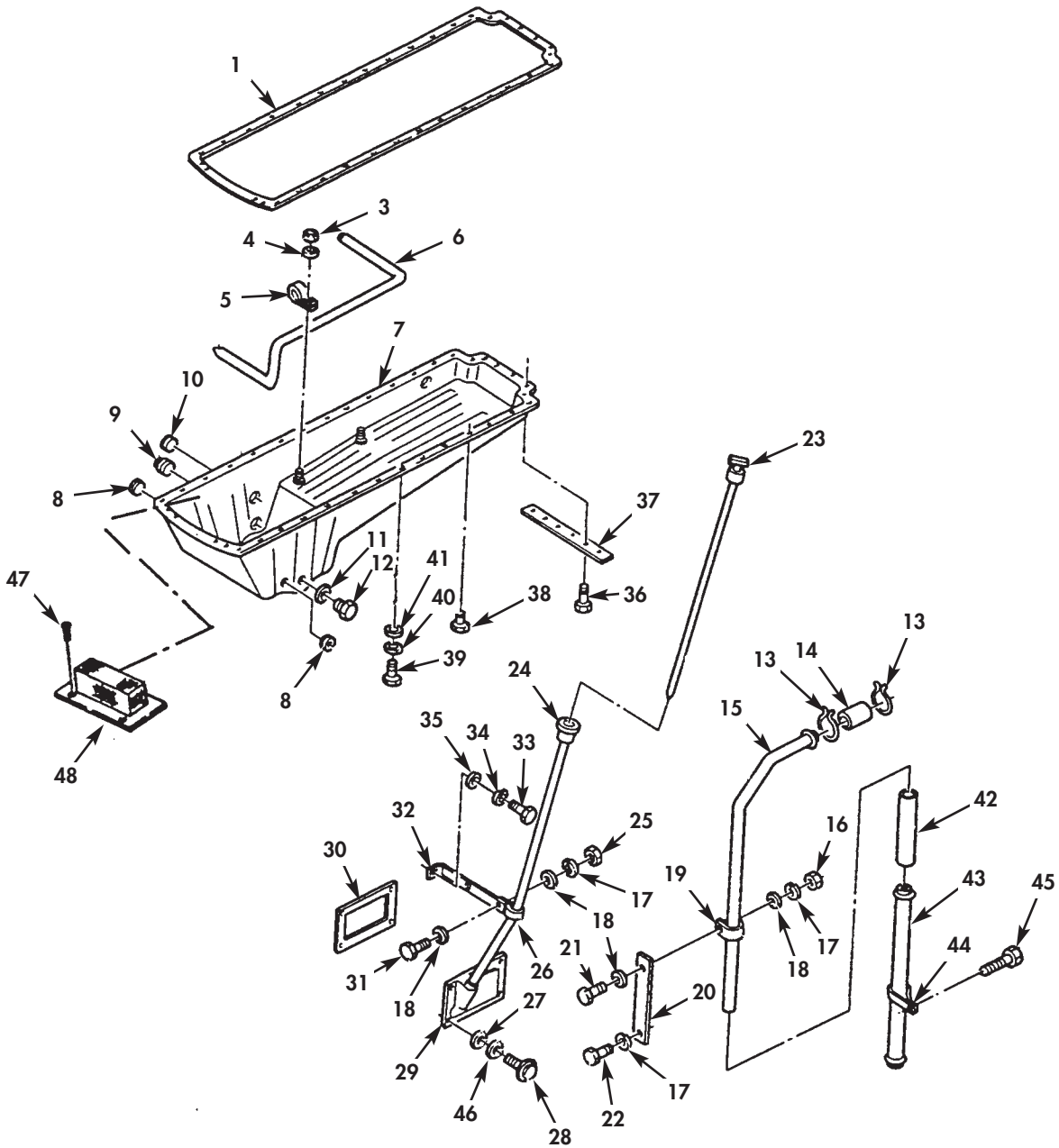
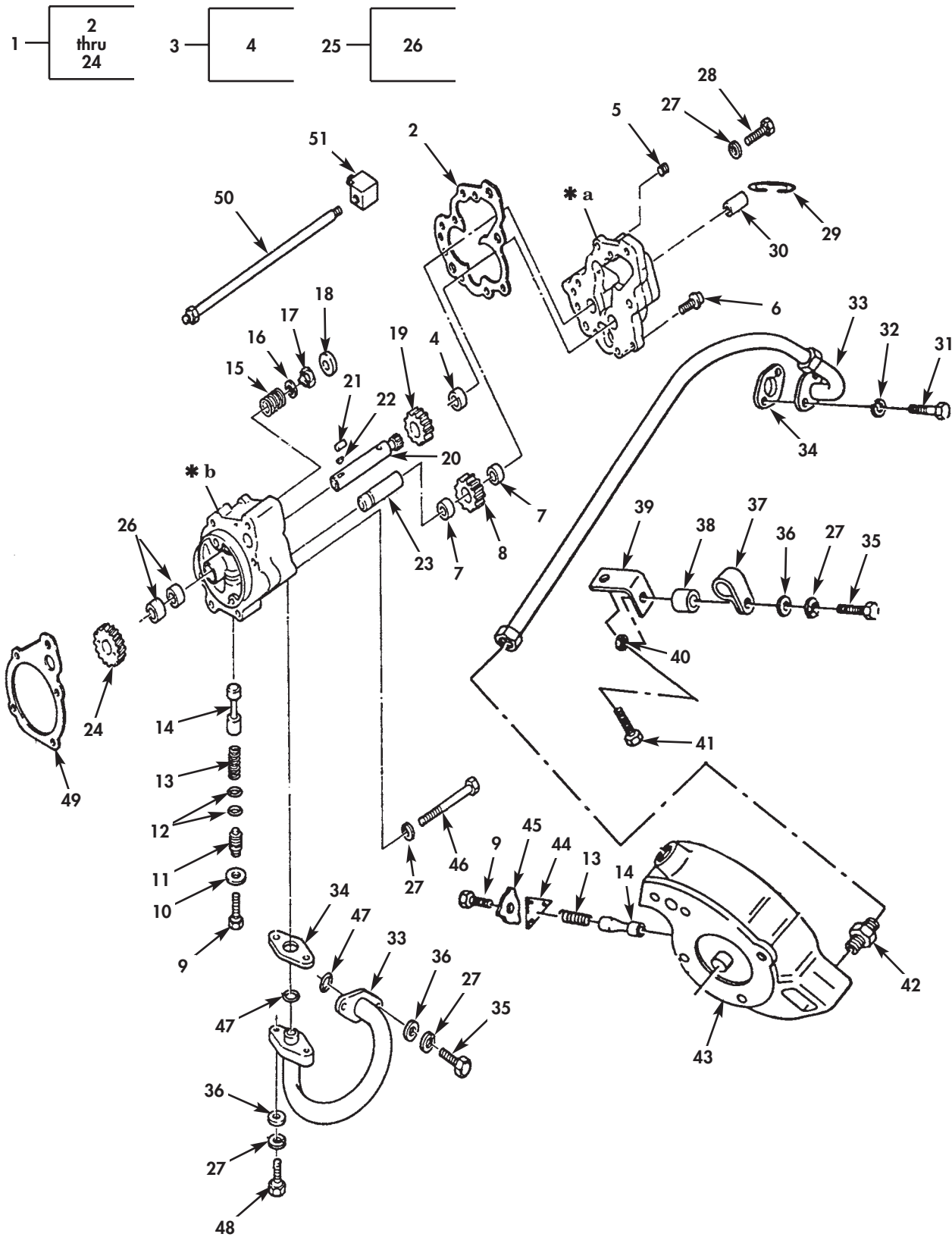


Figure 12. Oil Pan, Dipstick, and Breather Tube.

(1) ITEM NO	(2) SMR CODE	(3) NSN	(4) CAGEC	(5) PART NUMBER	(6) DESCRIPTION AND USABLE ON CODE(UOC)	(7) QTY
GROUP 0106 ENGINE LUBRICATION SYSTEM						
FIG. 12 OIL PAN, DIPSTICK, AND BREATHER TUBE						
1	PPFZZ	5330-01-147-0748	15434	3099083	GASKET PART OF KIT P/N 3801235.....	1
2	PAFZZ	2815-01-133-2445	15434	193625	OIL PAN BIG CAM I.....	1
2	PBFFF	2815-01-141-0919	15434	303195900	OIL PAN BIG CAM III.....	1
3	PAFZA	5310-00-828-4827	15434	69832	.NUT,GOVERNOR STUD 5/16-18.....	3
4	PAFZZ	5310-00-562-6558	15434	S-626	.WASHER,FLAT 0.344 X 0.688.....	3
5	PAFZZ	5340-01-146-9992	15434	3032708	.CLAMP,LOOP.....	3
6	PBFZZ	4710-01-146-1052	15434	3095051	.TUBE,BENT,METALLIC.....	1
7	XAFZZ		15434	3030257	.PAN, ENGINE OIL.....	1
8	PAFZZ	4730-00-010-3867	77640	103879	PLUG,PIPE BIG CAM I.....	2
8	PAFZZ	4730-99-214-1783	K4843	3008468	.PLUG,PIPE BIG CAM III.....	2
9	PAFZZ	5342-01-143-6045	15434	3008470	.PLUG 1-11 1/2.....	1
10	PAFZZ	4730-00-044-4715	15434	S962	.PLUG,PIPE 1 INCH NPTF.....	1
11	PCHZZ	5365-00-197-9327	15434	67946	.SPACER,RING PART OF KIT P/N 3801235.....	1
12	PAOZZ	5365-00-695-1247	15434	3055069	.PLUG,MACHINE THREAD.....	1
13	PAOZZ	4730-01-146-3111	15434	3008596	CLAMP,HOSE.....	2
14	PCOZZ	4720-00-278-4890	81336	33-5490-060-000	HOSE,NONMETALLIC.....	1
15	PFOZZ	4710-01-146-0049	15434	3038035	TUBE,BENT,METALLIC BIG CAM III.....	1
16	PAOZZ	5310-00-451-6643	15434	S-213-A	NUT,FLYWHEEL 5/8-18.....	1
17	PAOZZ	5310-00-261-7340	15434	S-604	WASHER,LOCK BIG CAM I.....	4
17	PAOZZ	5310-00-820-6653	15434	S-603	WASHER,LOCK BIG CAM III.....	4
18	PAOZZ	5310-00-823-8803	96906	MS27183-21	WASHER,FLAT.....	4
19	PAOZZ	5340-00-839-0653	15434	68425	CLAMP,LOOP.....	1
20	PFOZZ	5342-01-145-9540	15434	217934	BRACKET,AFTERCOOLER.....	1
21	PAOZZ	5305-00-944-8292	80205	MS35308-458	SCREW,CAP,HEXAGON H.....	1
22	PAOZZ	5305-00-546-6698	15434	S-129	SCREW,CAP,HEXAGON H 3/8-24 X 1.00..	1
23	PAOZZ	6680-01-108-7410	0B8S3	199453	GAGE ROD,LIQUID LEV.....	1
24	PAFZZ	4710-01-142-1667	15434	3022377	BREATHER TUBE,OIL.....	1
25	PAOZZ	5310-01-126-9404	24617	9422277	NUT,SELF-LOCKING,HE 3/8-16.....	1
26	PAOZZ	5340-00-417-5800	15434	200064	CLAMP,LOOP.....	1
27	PAFZZ	5310-00-080-6004	96906	MS27183-14	WASHER,FLAT BIG CAM III.....	4
28	PBFZZ	5305-01-085-8197	15434	3010595	SCREW,MACHINE WITH CAPTIVE WASHER, 3/8-16 X 1.00,BIG CAM III.....	4
29	PAFZZ	5342-01-140-7158	15434	178074	BRACKET BIG CAM I.....	1
29	XBFZZ		15434	41044	BRACKET,OIL GAGE BIG CAM III.....	1
30	PCFZZ	5330-00-246-0309	79150	26384	GASKET PART OF KIT P/N 3801235.....	1
31	PAHZZ	5305-00-543-4372	80204	B1821BH038C075N	SCREW,CAP,HEXAGON H BIG CAM I.....	5
32	PFOZZ	5340-01-147-5389	15434	134561	BRACKET,ANGLE.....	1
33	PAOZZ	5305-01-032-2311	80204	B1821BH044C425N	SCREW,CAP,HEXAGON H.....	1
34	PAOZZ	5310-00-209-0965	96906	MS35338-47	WASHER,LOCK BIG CAM I	1
35	PAOZZ	5310-00-809-4085	96906	MS27183-16	WASHER,FLAT BIG CAM III.....	1
36	PAHZZ	5305-01-212-5210	15434	3008069	SCREW,CAP,HEXAGON H BIG CAM I.....	4
36	PAFZZ	5305-01-145-8358	15434	3017049	SCREW,ASSEMBLED WAS BIG CAM III....	4
37	PPFZZ	5340-01-150-6248	15434	218813	PLATE,MENDING ENGINE SHIPPING BIG CAM III.....	1
38	PAFZZ	5305-01-145-1113	15434	3032674	SCREW HEXAGON.....	28
39	XBFZZ		80205	MS90725-90	SCREW,CAP,HEXAGON H 7/16-14 X 1 3/4	4
40	PAFZZ	5310-00-407-9566	96906	MS35338-45	WASHER,LOCK.....	4
41	PAFZZ	5310-00-081-4219	96906	MS27183-12	WASHER,FLAT.....	4
42	MOOZZ		19207	8710557-10	HOSE, RUBBER, MAKE FROM HOSE, NONMETALLIC, 10 IN. MAKE FROM P/N 8710557.....	1
43	PAOZZ	4710-01-092-0109	34623	MB320-20011	TUBE,METALLIC BREATHER EXTENSION...	1
44	PAOZZ	5340-01-153-9425	75272	COV-1109Z1	CLAMP,LOOP BIG CAM III.....	1
45	PAOZZ	5305-01-112-9021	15434	3013904	SCREW BIG CAM III.....	1
46	PAOZZ	5310-00-637-9541	96906	MS35338-46	WASHER,LOCK BIG CAM III.....	2

(1) Item NO	(2) SMR Code	(3) NSN	(4) CAGEC	(5) PART NUMBER	(6) DESCRIPTION AND USABLE ON CODE(UOC)	(7) Qty
47	XBFZZ		15434	S1354	SCREW BIG CAM I.....	2
48	PAFZZ	4730-00-338-6839	15434	2062200	STRAINER ELEMENT,SE BIG CAM I.....	1

END OF FIGURE



* a PART OF ITEM 3
 * b PART OF ITEM 25

Figure 13. Oil Lubricating Pump.

(1) ITEM NO	(2) SMR CODE	(3) NSN	(4) CAGEC	(5) PART NUMBER	(6) DESCRIPTION AND USABLE ON CODE(UOC)	(7) QTY
GROUP 0106 ENGINE LUBRICATION SYSTEM						
FIG. 13 OIL LUBRICATING PUMP						
1	PAFHH	2815-01-085-2573	15434	AR10172	OIL PUMP ASSEMBLY,E BIG CAM I.....	1
1	PAFHH	2815-01-141-5299	15434	3821572	PUMP ASSEMBLY,OIL BIG CAM III.....	1
2	PFHZZ	5330-01-147-1274	15434	3014778	.GASKET BIG CAM III PART OF KIT P/N 3801235.....	1
2	PAFZZ	5330-01-066-3910	15434	203145	.GASKET OIL COVER TO PUMP,BIG CAM I PART OF KIT P/N 3018762.....	1
3	XBHZZ		15434	AR8667	.HSG,HYDR ADAPTER BIG CAM I.....	1
3	PAHZZ	5340-01-145-9451	15434	3014964	.COVER,ACCESS BIG CAM III.....	1
4	PAHZZ	3120-00-627-6697	15434	69521	..BEARING,SLEEVE BIG CAM III.....	1
5	PAHZZ	4730-01-214-7081	10988	A77505	.PLUG,PIPE BIG CAM I.....	1
5	PAHZZ	4730-01-161-5115	15434	3013786	.PLUG,PIPE BIG CAM III.....	1
6	PAHZZ	5305-01-129-4214	15434	3022590	.SCREW,CAPTIVE WITH CAPTIVE WASHER, 5/16-18X1.00.....	7
7	PAHZZ	3120-00-566-0480	15434	68365	.BUSHING,SLEEVE BIG CAM I.....	2
7	PAHZZ	3120-01-149-5414	15434	199586	.BUSHING,SLEEVE BIG CAM III.....	2
8	PAHZZ	3020-01-146-0108	15434	3014788	.GEAR,SPUR.....	1
9	PAOZZ	5305-01-010-2362	96906	MS18154-59	.SCREW,CAP,HEXAGON H BIG CAM I.....	1
9	PAHZZ	5305-00-543-4372	80204	B1821BH038C075N	.SCREW,CAP,HEXAGON H BIG CAM III...	5
10	PAHZZ	5310-01-075-0991	15434	146161	.WASHER,FLAT.....	1
11	PAHZZ	5342-01-145-0645	15434	3012726	.RETAINER.....	1
12	PCHZZ	5330-01-051-4243	15434	145504	.PACKING,PREFORMED PART OF KIT P/N 3010242.....	2
13	PAHZZ	5360-01-038-4659	15434	211939	.SPRING,HELICAL,COMP BIG CAM I.....	1
13	PAHZZ	5360-01-145-7554	15434	3010146	.SPRING,HELICAL,COMP BIG CAM III...	1
14	PAHZZ	2815-00-705-2856	15434	109333	.PLUNGER,PRESSURE RE BIG CAM I.....	1
14	PAHZZ	5340-01-145-0802	15434	3012529	.PLUNGER,DETENT BIG CAM III.....	1
15	PAHZZ	5360-01-148-0303	15434	3014756	.SPRING,HELICAL,COMP BYPASS VALVE..	1
16	PAHZZ	5310-01-144-6224	15434	3014754	.WASHER,FLAT.....	1
17	PAHZZ	4820-01-145-9457	15434	3014755	.DISK,VALVE.....	1
18	PAHZZ	2940-01-146-1995	15434	179063	.SEAT,BYPASS FILTER.....	1
19	PAHZZ	3020-01-084-9640	15434	3014783	.GEAR,SPUR BIG CAM I.....	1
19	PAHZZ	3020-01-146-0109	15434	3014787	.GEAR,SPUR BIG CAM III.....	1
20	XDHZZ		15434	302136100	.SHAFT,SHOULDERED BIG CAM I.....	1
20	PAHZZ	3040-01-145-9637	15434	3012532	.GEARSHAFT,SPUR BIG CAM III.....	1
21	PAHZZ	5315-00-475-2574	15434	69519	.PIN,STRAIGHT,HEADLE.....	1
22	PAHZZ	5315-00-043-1787	80205	MS35756-34	.KEY,WOODRUFF BIG CAM I.....	1
22	XBHZZ		15434	183695	.KEY,WOODRUFF BIG CAM III.....	1
23	PAHZZ	3040-01-079-3469	15434	17741900	.SHAFT,SHOULDERED BIG CAM I.....	1
23	XDHZZ		15434	3012531	.SHAFT,STRAIGHT BIG CAM III.....	1
24	PAHZZ	3020-01-085-3779	15434	20483200	.GEAR,HELICAL.....	1
25	XDHZZ		15434	AR09832	BODY,OIL PUMP WITH BIG CAM I.....	1
25	PAHZZ	3040-01-146-5935	15434	3014798	HOUSING,MECHANICAL BIG CAM III.....	1
26	PAHZZ	3120-00-627-6697	15434	69521	.BEARING,SLEEVE BIG CAM III.....	2
27	PAFZZ	5310-00-261-7340	15434	S-604	WASHER,LOCK BIG CAM III.....	9
27	PAFZZ	5310-00-209-0965	96906	MS35338-47	WASHER,LOCK BIG CAM III.....	6
28	PAFZZ	5305-00-068-0511	80204	B1821BH038C125N	SCREW,CAP,HEXAGON H 0106 010A,BIG CAM I.....	13
28	PAFZZ	5305-00-137-3269	15434	S-108-A	SCREW BIG CAM III.....	3
29	PAFZZ	5325-01-084-9033	15434	100475	RING,RETAINING.....	1
30	XDHZZ		15434	199589	COUPLING,SHAFT,RIGI BIG CAM I.....	1
30	PAFZZ	3010-01-146-0113	15434	3023506	COUPLING,SHAFT,RIGI POWER STEERING PUMP,BIG CAM III.....	1
31	PAHZZ	5305-00-426-4142	15434	S105	SCREW,CAP,HEXAGON H BIG CAM I.....	2
32	PAHZZ	5310-00-637-9541	96906	MS35338-46	WASHER,LOCK PART OF KIT P/N 302112400.....	2
33	PAHZZ	4720-01-079-3285	34623	MA145B21000	HOSE ASSEMBLY,NONME BIG CAM I.....	1

(1) ITEM NO	(2) SMR CODE	(3) NSN	(4) CAGEC	(5) PART NUMBER	(6) DESCRIPTION AND USABLE ON CODE(UOC)	(7) QTY
33	PAFZZ	4710-01-146-0050	15434	3029848	TUBE,BENT,METALLIC BIG CAM III.....	1
34	PFFZZ	5330-01-145-6913	15434	3029846	GASKET PART OF KIT P/N 3801235.....	1
34	PCFZZ	5330-00-143-8376	15434	157551	GASKET PART OF KIT P/N 3801235.....	1
35	PAFZZ	5305-00-068-0511	80204	B1821BH038C125N	SCREW,CAP,HEXAGON H.....	2
36	PAFZZ	5310-00-562-6557	15434	S622	WASHER,FLAT GEAR COVER ASSY TO BLOCK,BIG CAM I.....	4
36	PAFZZ	5310-00-080-6004	96906	MS27183-14	WASHER,FLAT BIG CAM III.....	1
37	XBHZZ		15434	105182	CLAMP,LOOP PUMP ASSY,OIL LUBRICATING,BIG CAM I.....	1
38	XBHZZ		15434	9674F	SPACER CLAMP TO HOSE TO SUPPORT OIL PAN,PUMP ASSY,OIL LUBRICATING.....	1
39	PAHZZ	5340-01-066-2947	15434	68038	BRACKET,ANGLE PUMP ASSY,OIL LUBRICATING.....	1
40	PAHZZ	5310-00-521-8595	15434	S223	NUT,HEXAGON.....	1
41	XDHZZ		15434	300869	SCREW.....	1
42	PAHZZ	4730-00-202-8470	01276	2021-20-20S	ADAPTER,STRAIGHT,PI PUMP ASSY,OIL LUBRICATING,BIG CAM I.....	1
43	XDFZZ		15434	AR9832	BODY AND BUSHING.....	1
44	PAHZZ	2815-00-828-7013	15434	126304	YOKE,CAP RETAINING PUMP ASSY,OIL LUBRICATING, BIG CAM I.....	1
45	PAHZZ	2815-00-406-8936	15434	109319	LOCK PLATE YOKE TO HOUSING,PUMP ASSY,OIL LUBRICATING.....	1
46	PAFZZ	5305-00-795-9352	15434	3012479	SCREW,CAP,HEXAGON H BIG CAM I.....	2
46	PAFZZ	5305-01-147-2443	15434	S-142-A	SCREW,CAP,HEXAGON H BIG CAM III....	2
47	PAFZZ	5331-01-145-0715	15434	3029847	O-RING PART OF KIT P/N 3801235.....	1
48	PAFZZ	5305-00-543-4372	80204	B1821BH038C075N	SCREW,CAP,HEXAGON H BIG CAM III....	2
48	PAOZZ	5305-00-942-2196	80204	B1821BH038C100D	SCREW,CAP,HEXAGON H BIG CAM I.....	6
49	PFFZZ	5330-01-147-4071	15434	3031434	GASKET PUMP MOUNTING PART OF KIT P/N 3801235.....	1
50	PAFZZ	4720-01-152-0156	15434	AS0401100MS	HOSE ASSEMBLY,NONME.....	1
51	PAFZZ	4730-01-142-8524	15434	68139	ELBOW,PIPE TO TUBE.....	1

END OF FIGURE

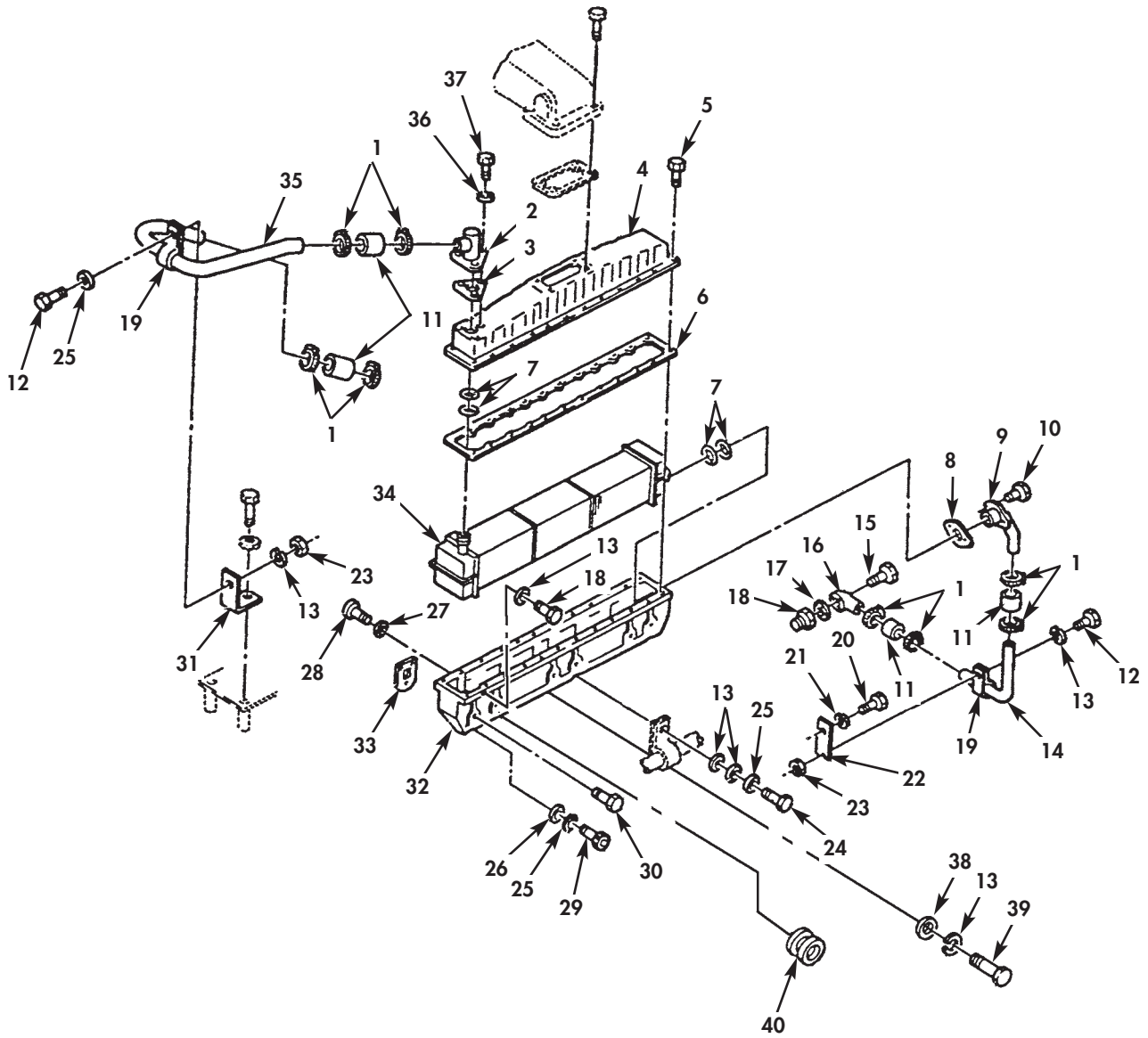


Figure 14. Air Aftercooler.

(1) ITEM NO	(2) SMR CODE	(3) NSN	(4) CAGEC	(5) PART NUMBER	(6) DESCRIPTION AND USABLE ON CODE(UOC)	(7) QTY
GROUP 0108 MANIFOLDS						
FIG. 14 AIR AFTERCOOLER						
1	PAOZZ	4730-00-555-8263	53496	5561 1-2A	CLAMP,HOSE 13/16-1 1/2.....	8
2	PFFZZ	4730-01-146-1065	15434	3013295	ELBOW,FLANGE TO HOS WATER	1
3	PCFZZ	5330-01-066-5351	15434	215044	OUTLET,BIG CAM III.....	1
4	PBFZZ	2930-01-146-1083	15434	3046170	GASKET WATER OUTLET	1
5	PAFZZ	5305-01-147-2444	15434	3005508	CONNECTION PART OF KIT P/N 4024958.	1
6	XBFZZ		15434	3077201	COVER,INTERCOOLER.....	24
7	PFOZZ	5330-01-066-3904	15434	195952	SCREW,CAP,HEXAGON H WITH CAPTIVE	1
8	PFOZZ	5330-01-147-4072	15434	3032348	WASHER.....	1
9	PAOZZ	2930-01-146-1996	15434	3028282	GASKET AFTERCOOLER COVER.....	4
10	PAOZZ	5305-00-068-0511	80204	B1821BH038C125N	PACKING,PREFORMED PART OF KIT	1
10	PAOZZ	5305-01-072-8818	15434	3012471	P/N 4024958.....	1
11	PCOZZ	4720-01-085-6131	15434	155789	GASKET WATER INLET CONNECTION PART	1
12	PAOZZ	5305-00-543-4372	80204	B1821BH038C075N	OF KIT P/N 4024958.....	1
13	PAOZZ	5310-00-159-6209	96906	MS122032	CONNECTOR,WATER INL WATER INLET,BIG	1
13	PAOZZ	5310-00-261-7340	15434	S-604	CAM III.....	2
14	PAOZZ	4710-01-146-4083	15434	217933	SCREW,CAP,HEXAGON H BIG CAM I.....	2
15	PAOZZ	5305-01-147-1215	15434	3019572	SCREW WITH CAPTIVE WASHER, 3/8-16 X	4
16	PAOZZ	4730-01-146-3109	15434	217932	1 1/8,BIG CAM III.....	2
17	PCOZZ	5330-01-082-6984	15434	215045	HOSE,NONMETALLIC.....	4
18	PFOZZ	4730-01-146-1064	15434	215587	SCREW,CAP,HEXAGON H HEXAGON CAP,	2
19	PAOZZ	5340-00-087-7486	15434	107460	3/8-16 X 1.00,BIG CAM III.....	3
20	PAOZZ	5305-00-944-8292	80205	MS35308-458	WASHER,LOCK BIG CAM I.....	2
21	PAOZZ	5310-00-820-6653	15434	S-603	WASHER,LOCK BIG CAM III.....	1
22	PAOZZ	5342-01-145-9540	15434	217934	TUBE,BENT,METALLIC WATER CROSSOVER.	1
23	PAOZZ	5310-00-521-8595	15434	S-223	SCREW,CAP,HEXAGON H WITH CAPTIVE	3
24	PAFZZ	5305-00-543-4372	80204	B1821BH038C075N	WASHER,BIG CAM III.....	1
24	PAOZZ	5305-01-137-6706	15434	3012473	ELBOW,FLANGE TO TUB WATER	1
25	PAOZZ	5310-00-261-7340	15434	S-604	OUTLET,BIG CAM III.....	1
25	PAOZZ	5310-00-486-2505	15434	108330	GASKET WATER OUTLET.....	1
26	PAOZZ	5310-00-080-6004	96906	MS27183-14	ADAPTER,STRAIGHT,FL WATER OUTLET...	1
27	PAFZZ	5310-01-145-8403	15434	3011610	CLAMP,LOOP.....	2
28	PAFZZ	5305-01-147-2445	15434	3030286	SCREW,CAP,HEXAGON H.....	1
29	PAFZZ	5305-01-146-7285	15434	69047-A	SCREW,CAP,HEXAGON H WITH CAPTIVE	3
30	PAFZZ	5305-00-404-1390	15434	S149A	WASHER,BIG CAM III.....	1
30	PAFZZ	5305-01-147-8729	15434	3028967	ELBOW,FLANGE TO TUB WATER	1
31	PAOZZ	5340-01-145-0773	15434	3035607	OUTLET,BIG CAM III.....	1
32	PBFZZ	4420-01-318-0852	15434	3036798	GASKET WATER OUTLET.....	1
33	PCFZZ	5330-01-086-3523	15434	3008591	ADAPTER,STRAIGHT,FL WATER OUTLET...	1
34	XBFZZ		15434	214836	CLAMP,LOOP.....	2
34	PAFZZ	2930-01-141-9277	15434	3068724	SCREW,CAP,HEXAGON H.....	1
35	PAOZZ	4710-01-085-6132	15434	21504100	SCREW,CAP,HEXAGON H WITH CAPTIVE	6
					WASHER, 3/8-16 X 1.125,BIG CAM III..	6
					BRACKET,ANGLE TUBE SUPPORT,BIG CAM	1
					III.....	1
					COOLER,FLUID,INDUST BIG CAM III....	1
					GASKET INTAKE MANIFOLD PART OF KIT	3
					P/N 4024958 PART OF KIT P/N 3804280.	1
					CORE,AFTERCOOLER BIG CAM I.....	1
					CORE,AFTERCOOLER BIG CAM III.....	1
					TUBE,BENT,METALLIC BIG CAM I.....	1

(1) ITEM NO	(2) SMR CODE	(3) NSN	(4) CAGEC	(5) PART NUMBER	(6) DESCRIPTION AND USABLE ON CODE(UOC)	(7) QTY
35	PAOZZ	4710-01-146-1053	15434	3018099	TUBE,BENT,METALLIC WATER TRANSFER,BIG CAM III.....	1
36	PAFZZ	5330-00-003-1771	15434	S684	GASKET BIG CAM I.....	3
37	PAFZZ	5306-00-225-8499	96906	MS90725-34	BOLT,MACHINE 5/16-18 X 1.00.....	3
38	PAFZZ	5310-00-134-4169	15434	63842	WASHER,FLAT.....	3
39	PAHZZ	5305-00-725-2317	80204	B1821BH038C150N	SCREW,CAP,HEXAGON H 3/8-16 X 1.50..	3
40	PAFZZ	4730-00-018-9566	15434	S911B	PLUG,PIPE.....	1

END OF FIGURE

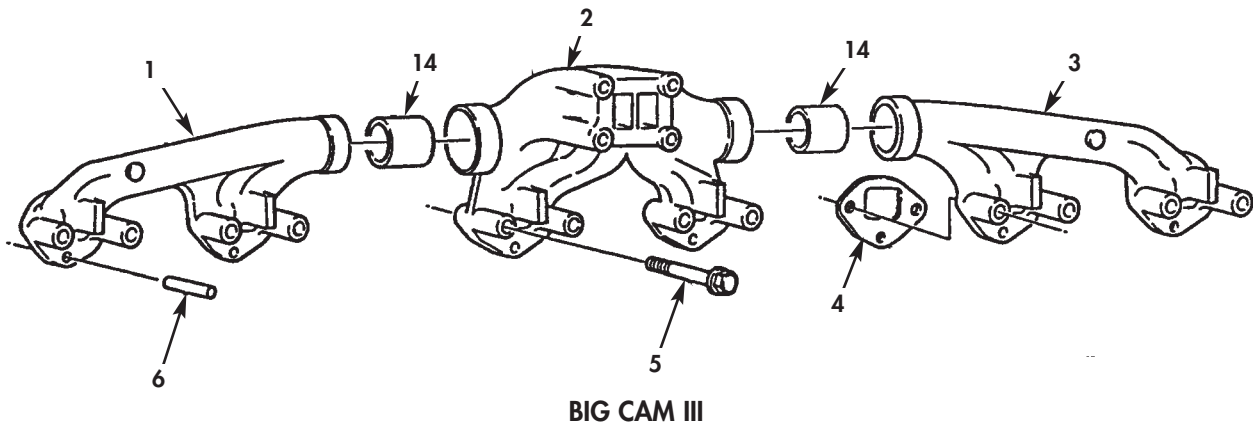
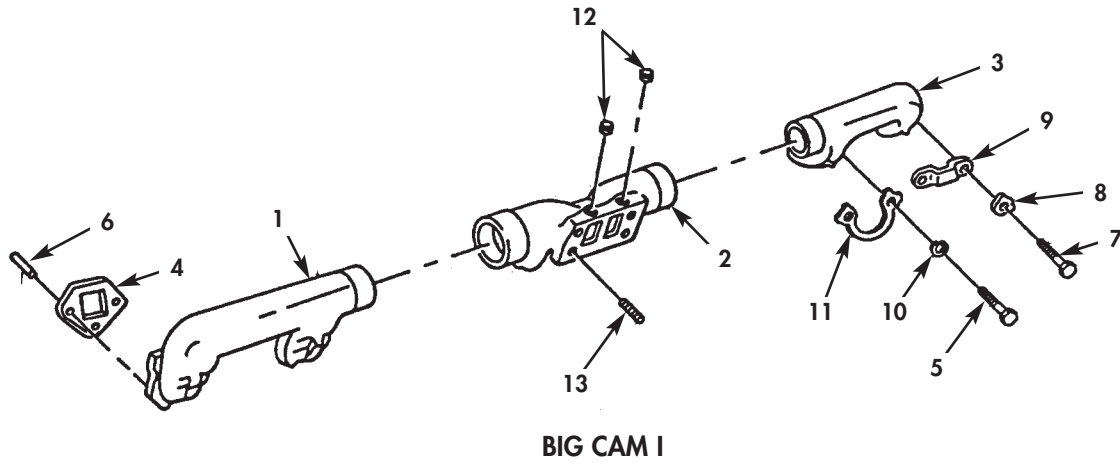


Figure 15. Exhaust Manifolds.

(1) ITEM NO	(2) SMR CODE	(3) NSN	(4) CAGEC	(5) PART NUMBER	(6) DESCRIPTION AND USABLE ON CODE(UOC)	(7) QTY
GROUP 0108 MANIFOLDS						
FIG. 15 EXHAUST MANIFOLDS						
1	PAFZZ	2815-00-920-8356	15434	151489	MANIFOLD,EXHAUST EXHAUST MANIFOLDS,BIG CAM I.....	1
1	PAFZZ	2815-01-146-1103	15434	3031186	MANIFOLD,EXHAUST REAR,BIG CAM III..	1
2	PAFZZ	2815-01-077-4463	15434	200566	MANIFOLD,CENTER SEC REAR,EXHAUST MANIFOLDS ASSEMBLY,BIG CAM I.....	1
2	PAFZZ	2815-01-146-3159	15434	3029614	MANIFOLD,EXHAUST CENTER,BIG CAM III	1
3	PAFZZ	2815-00-920-2073	15434	151478	MANIFOLD,EXHAUST EXHAUST MANIFOLDS,BIG CAM I.....	1
3	PAFZZ	2815-01-146-0112	15434	3031187	MANIFOLD,EXHAUST FRONT,BIG CAM III.	1
4	PAFZZ	5330-00-659-3178	15434	3020943	GASKET MANIFOLD PART OF KIT P/N 4024958 PART OF KIT 3804280.....	6
5	PAFZZ	5305-01-028-8869	15434	S155	SCREW,CAP,HEXAGON H BIG CAM I.....	8
5	PAFZZ	5305-01-147-8730	15434	3043647	SCREW,CAP,HEXAGON H CAPTIVE WASHER,BIG CAM III.....	12
6	PAFZZ	2815-00-829-5227	15434	105199	DOWEL,MANIFOLD.....	6
7	PAFZZ	5305-00-843-9529	94012	110266	SCREW,CAP,HEXAGON H BIG CAM I.....	4
8	PAFZZ	5310-00-887-8325	15434	114638	WASHER,KEY BIG CAM I.....	4
9	PAFZZ	5340-00-132-3203	15434	200919	STRAP,RETAINING BIG CAM I.....	2
10	PAFZZ	3120-01-079-6527	15434	109594	BEARING,SLEEVE BIG CAM I.....	8
11	PAFZZ	5340-00-767-4012	15434	116982	LOCKING PLATE,NUT A BIG CAM I.....	4
12	PAFZZ	4730-01-085-7328	15434	217632	PLUG,PIPE BIG CAM I.....	2
13	PAFZZ	5307-00-922-2626	15434	3010915	STUD,PLAIN BIG CAM I.....	4
14	PAFZZ		15434	3027653	RING,EXHAUST BIG CAM III.....	2
END OF FIGURE						

1 — 2
and
3

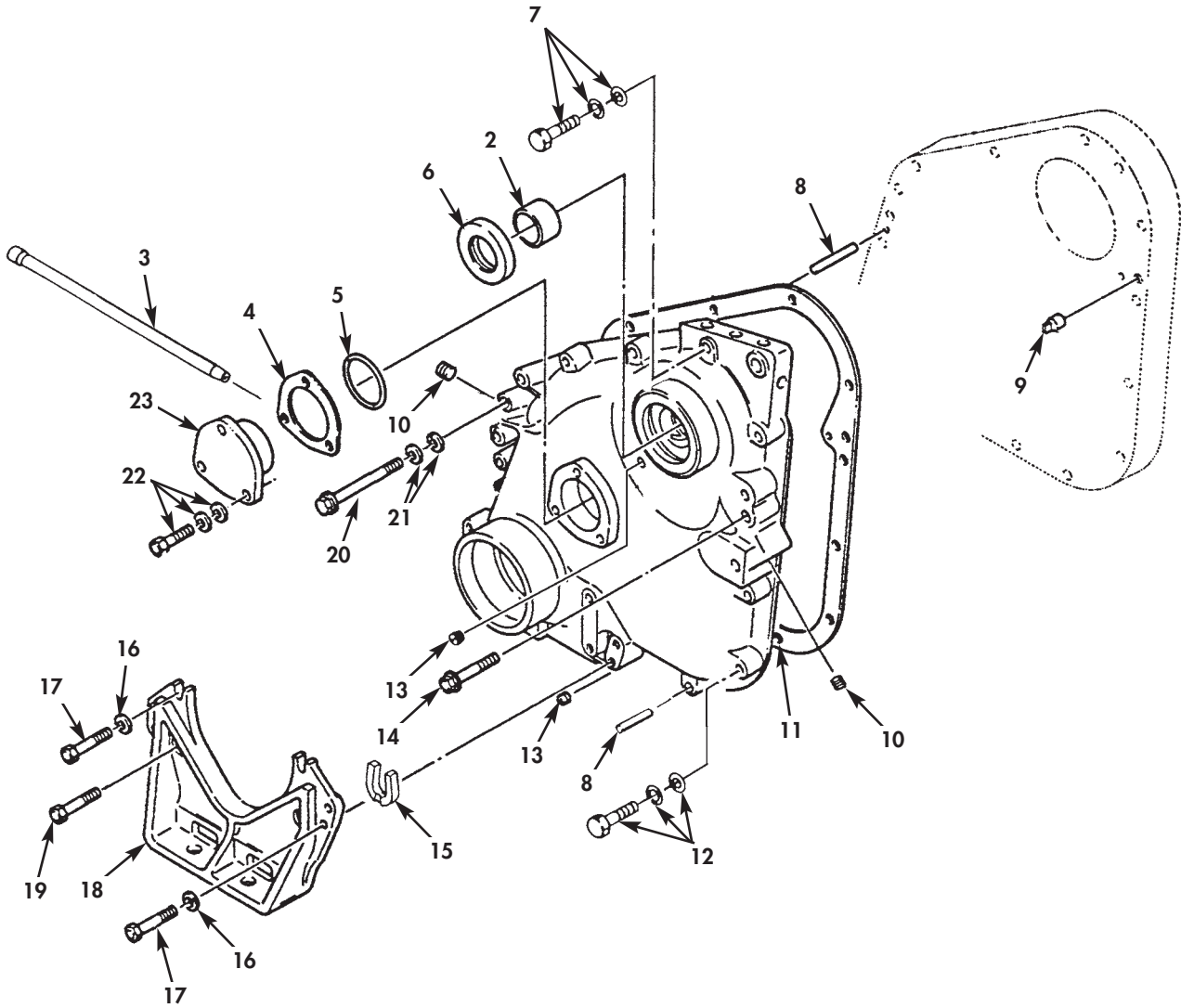
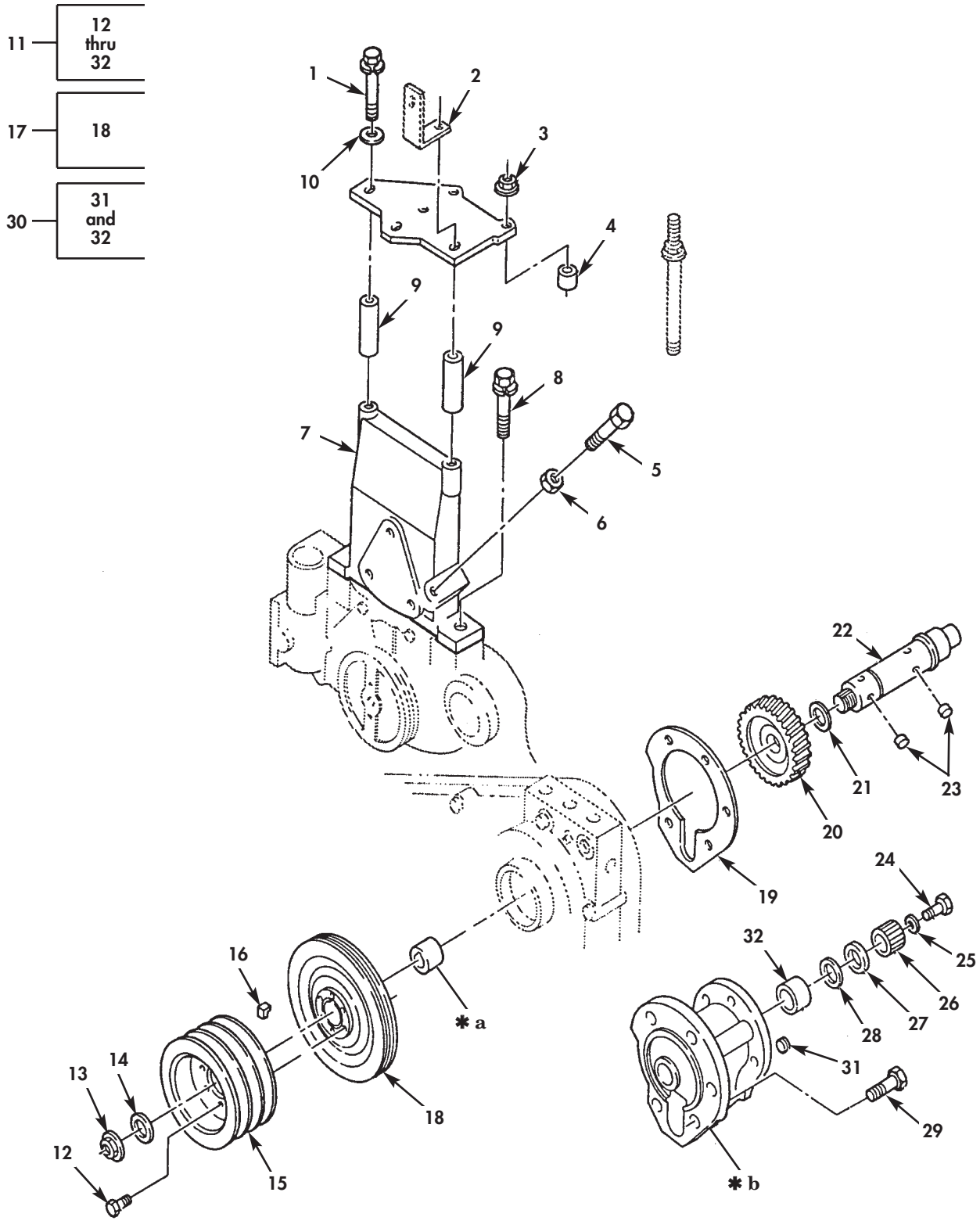


Figure 16. Gear Cover.

(1) ITEM NO	(2) SMR CODE	(3) NSN	(4) CAGEC	(5) PART NUMBER	(6) DESCRIPTION AND USABLE ON CODE(UOC)	(7) QTY
GROUP 0109 ACCESSORY DRIVING MECHANISIMS						
FIG. 16 GEAR COVER						
1	PAFZZ	2815-01-159-0872	15434	3024442	GEAR COVER ASSEMBLY.....	1
2	PAFZZ	3120-00-877-2213	15434	132770	.BEARING,SLEEVE.....	1
3	PAFZZ	4710-01-209-6742	15434	210416	.TUBE,METALLIC.....	1
4	PAFZZ	5365-01-147-0912	15434	65259-A	SHIM PART OF KIT P/N AR01176.....	V
4	PAFZZ	5365-01-147-0913	15434	65259-B	SHIM PART OF KIT P/N AR01176.....	V
4	PAFZZ	5365-00-507-3254	15434	65259-C	SHIM 0.002 PART OF KIT P/N AR01176	V
4	PAFZZ	5365-01-086-7788	15434	185573	SHIM PART OF KIT P/N AR01176.....	V
5	PCFZZ	5331-01-145-0716	15434	215705	O-RING PART OF KIT P/N 3801235.....	1
6	PAFZZ	5330-00-135-6382	15434	211255	SEAL,PLAIN ENCASED PART OF KIT P/N 3801235.....	1
7	PAFZZ	5305-01-145-8381	15434	3011713	SCREW,CAP,HEXAGON H 7/16-20 X 2 5/8	1
8	PAFZZ	2815-00-772-9434	15434	70653	DOWEL,METALLIC.....	1
9	PAFZZ	5315-00-238-0882	15434	60408	PIN,STRAIGHT,HEADLE.....	1
10	PAFZZ	4730-00-018-9566	15434	S-911-B	PLUG,PIPE 1/8 NPTF.....	2
11	PCFZZ	5330-01-145-6914	15434	3021704	GASKET PART OF KIT P/N 3801235.....	1
12	PAFZZ	5305-01-147-4033	15434	3011711	SCREW,CAP,HEXAGON H WITH CAPTIVE WASHERS,7/16-20 X 1-3/8.(SUPRESSED - DUPP/N IN CHETPM, BLSB). BIG CAM I..	9
12	PAFZZ	5305-01-240-7155	15434	3011712	SCREW,ASSEMBLED WAS 7/16-20 X 2 3/16 BIG CAM III.....	9
13	PFHZZ	4730-00-042-8988	7X677	117244	PLUG,PIPE 1/4 NPT BIG CAM I.....	3
13	PAFZZ	4730-00-010-3867	24617	219191	PLUG,PIPE 3/8 NPT BIG CAM III.....	1
14	PAFZZ	5305-01-165-3300	15434	S-119-C	SCREW,CAP,HEXAGON H.....	1
15	XBFZZ		15434	218716	SPACER,PLATE.....	8
16	PAFZZ	5310-01-112-4306	15434	203760	WASHER,FLAT 15/32 I.D. BIG CAM I...	2
16	PAFZZ	5310-01-145-8404	15434	3000082	WASHER,FLAT 15/32 BIG CAM III.....	6
17	PAFZZ	5305-01-147-8731	15434	213456	SCREW,CAP,HEXAGON H ENGINE SUPPORT TO ENGINE.....	6
18	PAFZZ	2815-01-079-9146	15434	214306	SUPPORT,FRONT,ENGIN.....	1
19	PAFZZ	5306-01-146-9866	15434	3058664	BOLT,MACHINE 7/16-20 X 2.50.....	2
20	PAFZZ	5305-01-165-3892	15434	3011714	SCREW 7/16-20 X 3.00.....	3
21	PAHZZ	5310-00-209-0965	96906	MS35338-47	WASHER,LOCK 7/16 BIG CAM I.....	1
22	PAFZZ	5305-01-072-8816	15434	3011715	SCREW 3/8-16 X 13/16.....	3
23	PAFZZ	2815-01-145-9401	15434	3008530	SUPPORT,CAMSHAFT.....	1

END OF FIGURE



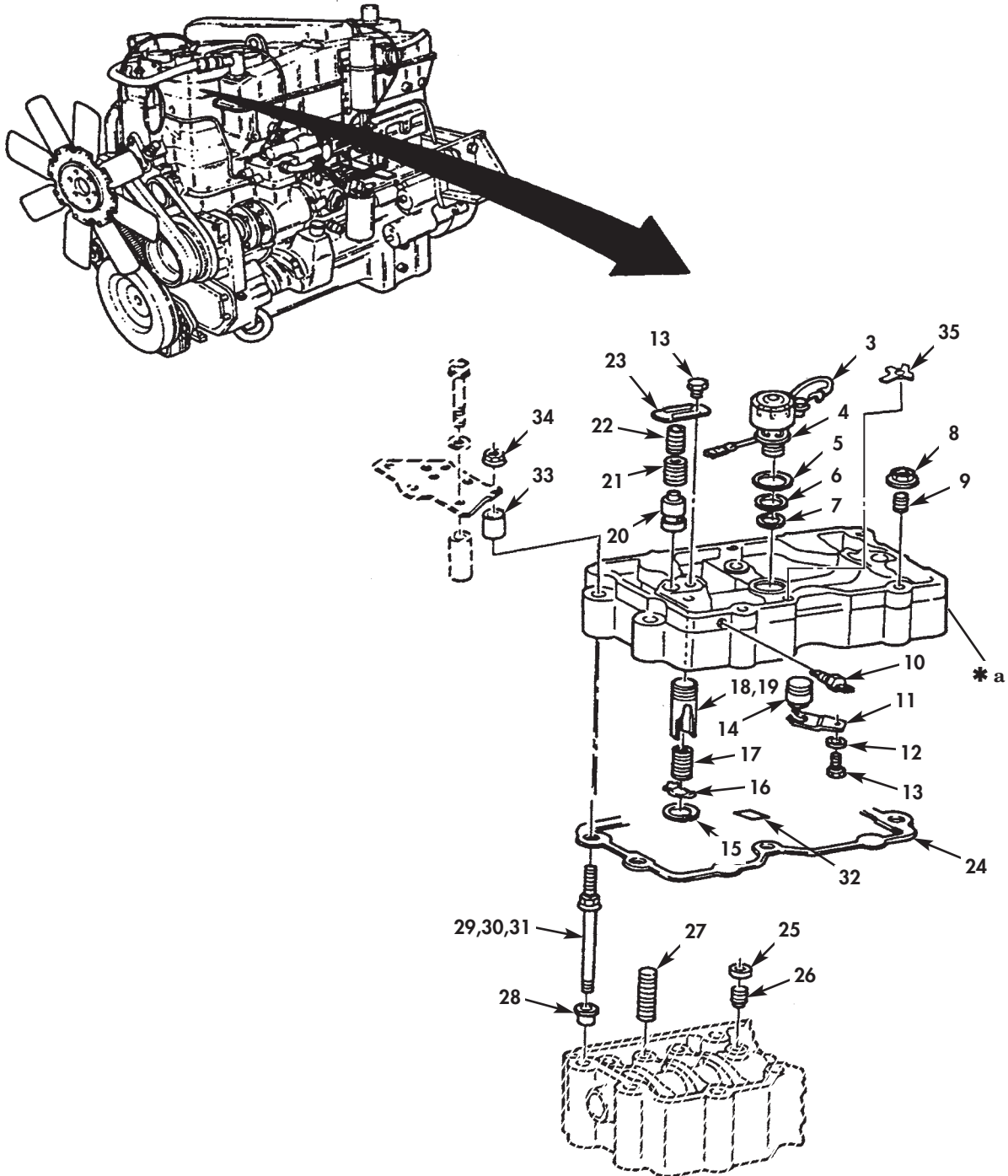
* a PART OF ITEM 17
 * b PART OF ITEM 30

Figure 17. Accessory Drive Pulley and Fan Clutch.

(1) ITEM NO	(2) SMR CODE	(3) NSN	(4) CAGEC	(5) PART NUMBER	(6) DESCRIPTION AND USABLE ON CODE(UOC)	(7) QTY
GROUP 0109 ACCESSORY DRIVING MECHANISIMS						
FIG. 17 ACCESSORY DRIVE PULLEY AND FAN CLUTCH						
1	PAOZZ	5305-01-145-8382	75078	012647	SCREW,CAP,HEXAGON H WITH CAPTIVE WASHER, SEE GROUP 0112.....	1
2	PAOZZ	2930-01-097-6755	15434	217034	BRACE,FAN BRACKET.....	1
3	PAOZZ	5310-01-144-6115	75078	001094	NUT,PLAIN,CONE SEAT.....	2
4	PAOZZ	5365-01-147-5030	75078	001234	SPACER,SLEEVE SEE GROUP 0112.....	1
5	PAOZZ	5305-01-091-2498	15434	166777	SCREW 1/2-13.....	1
6	PAOZZ	5310-00-470-6154	15434	S-285	NUT,PLAIN,HEXAGON 1/2-13.....	1
7	PBOZZ	5342-01-098-0175	15434	208829	BRACKET,FAN SUPPORT.....	1
8	PAOZZ	5305-01-145-0776	15434	3019574	SCREW,CAP,HEXAGON H WITH CAPTIVE WASHER.....	2
9	PAOZZ	5365-01-095-5666	75078	003251	SPACER,SLEEVE FAN BRACE, SEE GROUP 0112.....	2
10	PAHZZ	5310-01-145-8405	75078	001030	WASHER,FLAT.....	1
11	PAFFH	4310-01-092-9815	15434	3005133	DRIVE ACCESSORY,COM.....	1
12	PAFZZ	5305-01-145-8383	15434	175833	.SCREW,CAP,HEXAGON H 3/8-16 X 1 1/8	6
13	PAFZZ	5310-01-126-1045	15434	3012526	.NUT,SELF-LOCKING,HE.....	1
14	PAFZZ	5310-01-124-6463	15434	193136	.WASHER,FLAT.....	1
15	PAFZZ	3020-01-146-3773	15434	3013336	.PULLEY,CONE ACCESSORY DRIVE.....	1
16	PCFZZ	5330-01-129-6541	15434	3008947	.RUBBER STRIP.....	1
17	PAFZZ	3020-01-146-3163	15434	3023473	.PULLEY,FLAT ACCESSORY DRIVE.....	1
18	PAFZZ	2930-00-401-9531	15434	190397	..SLEEVE,PULLEY,PUMP.....	1
19	PCFZZ	5330-00-026-2931	15434	3069101	.GASKET PART OF KIT P/N 3801235....	1
20	PAFZZ	3020-00-160-9092	15434	142689	.GEAR,HELICAL ACCESSORY DRIVE.....	1
21	PAFZZ	3120-01-147-5275	15434	3026556	.BEARING,WASHER,THRU.....	1
22	PAFZZ	4310-01-092-9816	15434	3000171	.SHAFT,AIR COMPRESSO ACCESSORY DRIVE.....	1
23	PAFZZ	2815-01-124-0232	15434	70550	.PIN,PISTON.....	2
24	PAFZZ	5306-01-119-4271	15434	3000173	.BOLT,INTERNALLY REL SELF-LOCKING, 3/8-16 X 1.00.....	1
25	PAFZZ	5310-00-486-2507	15434	170664	.WASHER,FLAT.....	2
26	PAFZZ	3010-01-085-2732	15434	3000174	.COUPLING HALF,SHAFT SPLINE COUPLING.....	1
27	PAFZZ	5310-00-081-9292	15434	116390	.WASHER,FLAT.....	1
28	PAFZZ	3120-01-144-7368	15434	3026557	.BEARING,WASHER,THRU.....	1
29	PAFZZ	5305-01-119-8621	15434	3010590	.SCREW WITH CAPTIVE WASHER, 7/16-20 X 1.125/1.063.....	5
30	PAFZZ	3040-01-129-4302	15434	AR-45724	.HOUSING,MECHANICAL ACCESSORY DRIVE	1
31	PAFZZ	4730-00-018-9566	15434	S-911-B	..PLUG,PIPE.....	2
32	PAFZZ	3120-00-792-9834	15434	116391	..BEARING,SLEEVE.....	1

END OF FIGURE

- 1 — 2 thru 31
- 2 — 3 thru 23

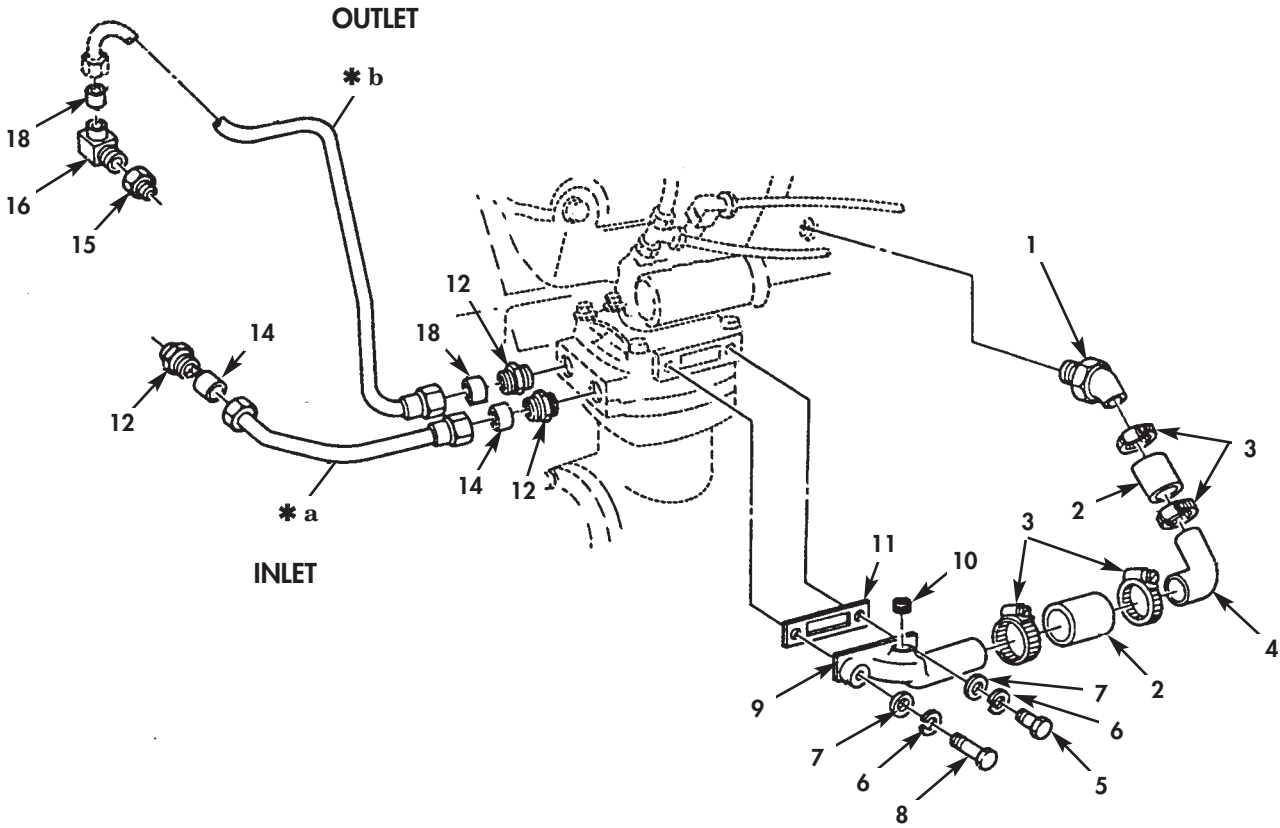
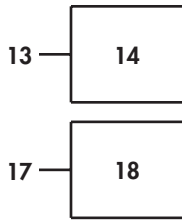


* a PART OF ITEM 1

Figure 18. Engine Retarder.

(1) ITEM NO	(2) SMR CODE	(3) NSN	(4) CAGEC	(5) PART NUMBER	(6) DESCRIPTION AND USABLE ON CODE(UOC)	(7) QTY
GROUP 0112 ENGINE BRAKE						
FIG. 18 ENGINE RETARDER						
1	PAFHH	2815-01-085-2574	0B8S3	3804587	BRAKE ASSEMBLY, ENGI ENGINE BRAKE...	1
2	PAFHH	2815-01-141-3261	75078	009917	.HOUSING, ENGINE RETA BRAKE.....	3
3	PCHZZ	6150-01-114-7119	75078	002390	..LEAD, ELECTRICAL.....	1
4	PAHZZ	4810-01-225-6010	75078	013472	..VALVE ASSEMBLY, NEED SOLENOID, BIG CAM III.....	1
5	PCHZZ	5331-01-086-1013	75078	20229	..O-RING.....	1
6	PCHZZ	5331-01-085-3105	75078	001082	..O-RING.....	1
7	PAHZZ	5330-01-086-6196	75078	001083	..PACKING, PREFORMED.....	1
8	PAHZZ	5310-01-157-3762	75078	001026	..NUT, PLAIN, HEXAGON BIG CAM I.....	2
8	PAHZZ	5310-01-146-7302	75078	009353	..NUT, SELF-LOCKING, EX BIG CAM III..	2
9	PAHZZ	5305-01-186-7042	75078	001031	..SETSCREW 0.375- 24X0.75 IN. LG, RETARDER, ENGINE-JACOBS BR., BIG CAM I.....	2
9	PAHZZ	5305-01-144-6206	75078	009916	..SETSCREW BIG CAM III.....	2
10	PAHZZ	5940-01-085-4426	75078	002299	..TERMINAL, FEEDTHRU, I.....	1
11	PAHZZ	5360-01-145-7607	75078	007447	..SPRING, FLAT MASTER PISTON.....	2
12	PAHZZ	5310-01-145-8405	75078	001030	..WASHER, FLAT.....	1
13	PAHZZ	5305-01-145-8384	75078	001492	..SCREW, CAP, HEXAGON H.....	2
14	PAHZZ	2815-01-088-7328	75078	004089	..PISTON, MASTER.....	2
15	PAHZZ	5325-01-087-8727	75078	001023	..RING, RETAINING.....	2
16	PAHZZ	5340-01-085-4439	75078	008895	..RETAINER, HELICAL CO SLAVE PISTON.	2
17	PAHZZ	5360-01-084-9066	75078	001022	..SPRING, HELICAL, COMP.....	2
18	PAHZZ	2815-01-098-6755	75078	007623	..PISTON, SLAVE.....	2
19	PAHZZ	2815-01-146-1997	75078	007696	..PISTON, SLAVE SLAVE, FOR MILLED CYLINDER HEADS.....	2
20	PAHZZ	4820-01-089-3939	75078	001521	..CARTRIDGE, CHECK VAL BIG CAM I....	2
20	PAHZZ	4820-01-146-4593	75078	007505	..VALVE, CHECK BIG CAM III.....	2
21	PAHZZ	5360-01-089-9103	75078	001519	..SPRING CONTROL VALVE, OUTER.....	2
22	PAHZZ	5360-01-145-7555	75078	007500	..SPRING, HELICAL, COMP CONTROL VALVE, INNER.....	2
23	PAHZZ	2815-01-145-9402	75078	004136	..PLATE, COVER, VALVE, D CONTROL VALVE	2
24	PCFZZ	5330-01-086-3996	75078	13294	.GASKET BRAKE HOUSING.....	3
25	PCFZZ	5330-01-145-6083	75078	010180	.PACKING, PREFORMED.....	3
26	PAFZZ	2520-01-085-6128	75078	002969	.SCREW SHAFT LOCK.....	2
27	PAFZZ	5307-01-109-5972	75078	1764	.STUD, SHOULDERED AND BIG CAM I....	2
27	PAFZZ	5306-01-107-6371	75078	3678	.BOLT, EXTERNALLY REL BIG CAM III...	1
28	PAFZZ	5310-01-147-5072	75078	002514	.WASHER, BEAING.....	1
29	PFFZZ	5307-01-147-1316	75078	2856	.STUD, SHOULDERED.....	2
30	PAFZZ	5307-01-147-2821	75078	1232	.STUD, SHOULDERED.....	4
31	PAFZZ	5307-01-145-8449	75078	001199	.STUD, SHOULDERED.....	8
32	PAOZZ		15434	3045534	SEAL, RECTANGULAR.....	1
33	PAOZZ	5365-01-147-5030	75078	001234	SPACER, SLEEVE.....	6
34	PAOZZ	5310-01-144-6115	75078	001094	NUT, PLAIN, CONE SEAT.....	6
35	PAFZZ		75078	002680	LOCKPLATE, ENGINE BR.....	6

END OF FIGURE



- * a PART OF ITEM 13
- * b PART OF ITEM 17

Figure 19. Air Compressor Lines and Fittings.

(1) ITEM NO	(2) SMR CODE	(3) NSN	(4) CAGEC	(5) PART NUMBER	(6) DESCRIPTION AND USABLE ON CODE(UOC)	(7) QTY
GROUP 0121 COMPRESSOR ASSEMBLY						
FIG. 19 AIR COMPRESSOR LINES AND FITTINGS						
1	PAOZZ	4730-01-079-3273	15434	300207400	ELBOW,PIPE TO HOSE AIR INTAKE.....	1
2	PCOZZ	4720-00-918-9634	15434	61554	HOSE,PREFORMED.....	2
3	PAOZZ	4730-00-555-8263	53496	5561 1-2A	CLAMP,HOSE.....	4
4	PAOZZ	4710-01-146-3085	15434	217939	TUBE,BENT,METALLIC.....	1
5	PAOZZ	5305-00-226-4831	80204	B1821BH031C150N	SCREW,CAP,HEXAGON H 5/16-18 X 1.50.	1
6	PAOZZ	5310-00-407-9566	96906	MS35338-45	WASHER,LOCK.....	2
7	PAOZZ	5310-00-562-6558	15434	S-626	WASHER,FLAT.....	2
8	PAOZZ	5305-01-129-4214	15434	3022590	SCREW,CAPTIVE.....	1
9	PAOZZ	4730-01-085-4156	15434	196282	ELBOW,FLANGE TO HOS AIR COMPRESSOR INTAKE.....	1
10	PAOZZ	4730-00-018-9566	15434	S-911-B	PLUG,PIPE.....	1
11	PAOZZ	5330-01-181-0630	15434	3201386	GASKET.....	1
12	PAOZZ	4730-00-365-2690	15434	S-1002-A	ADAPTER,STRAIGHT,TU.....	3
13	PAOZZ	4710-01-095-8683	15434	21609300	TUBE ASSEMBLY,METAL OUTLET BIG CAM III.....	1
13	PAOZZ	4710-01-079-3492	15434	3038060	TUBE ASSEMBLY,METAL COMPRESSOR COOLING BIG CAM I.....	1
14	PAOZZ	5365-00-598-5255	15434	S-1003-A	.BUSHING,NONMETALLIC.....	2
15	PAOZZ	4730-00-138-3906	15434	187317	COUPLING,PIPE PLAIN STRAIGHT, 3/8 NPT.....	1
16	PAOZZ	4730-00-374-4282	15434	S00100500A	ELBOW,PIPE TO TUBE.....	1
17	PAOZZ	4710-01-146-3168	15434	3028642	TUBE ASSEMBLY,METAL COMPRESSOR COOLING BIG CAM I.....	1
17	PAOZZ	4710-01-079-3492	15434	3038060	TUBE ASSEMBLY,METAL OUTLET BIG CAM III.....	1
18	PAOZZ	5365-00-598-5255	15434	S-1003-A	.BUSHING,NONMETALLIC.....	2

END OF FIGURE

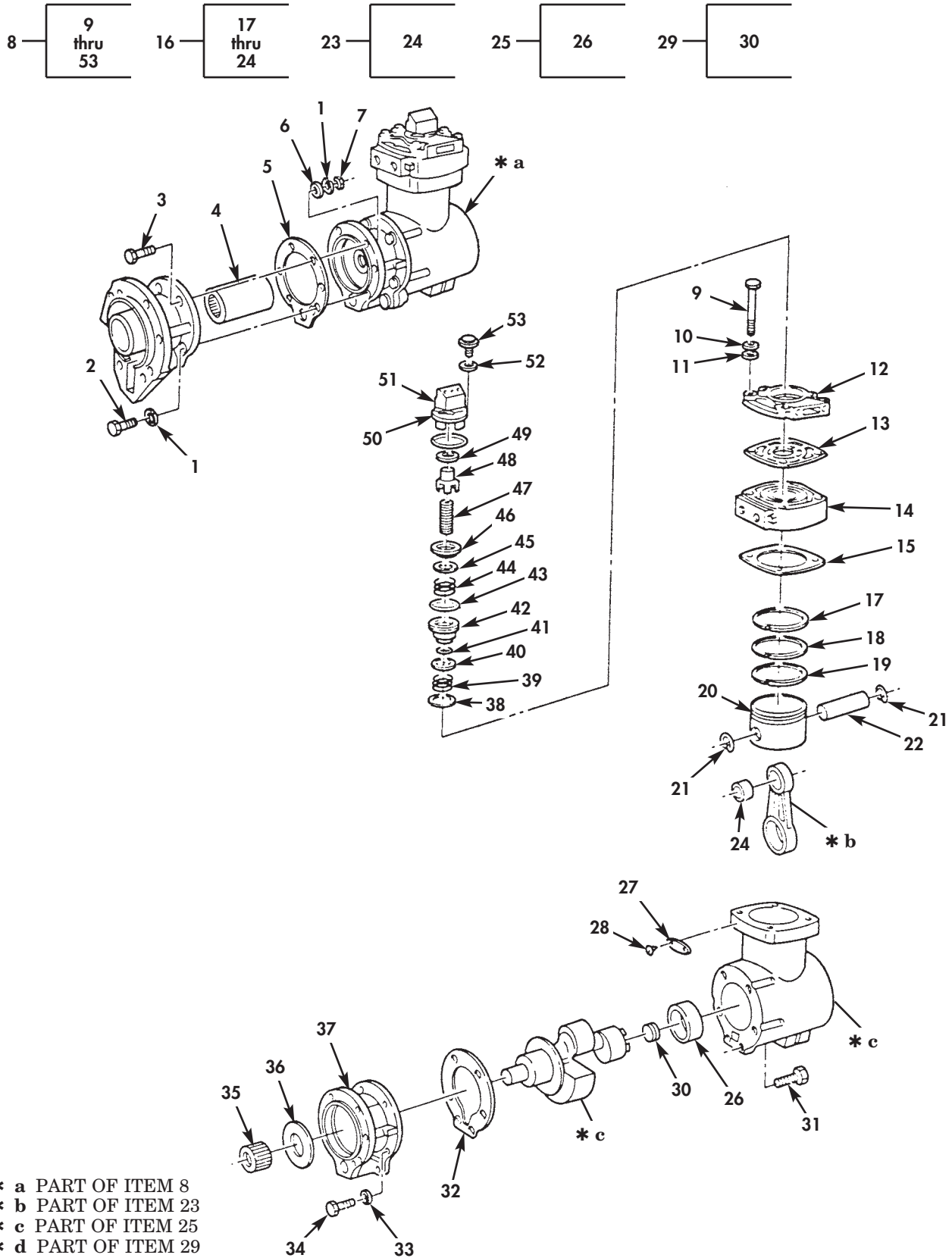


Figure 20. Air Compressor and Governor Assembly (Sheet 1 of 2).

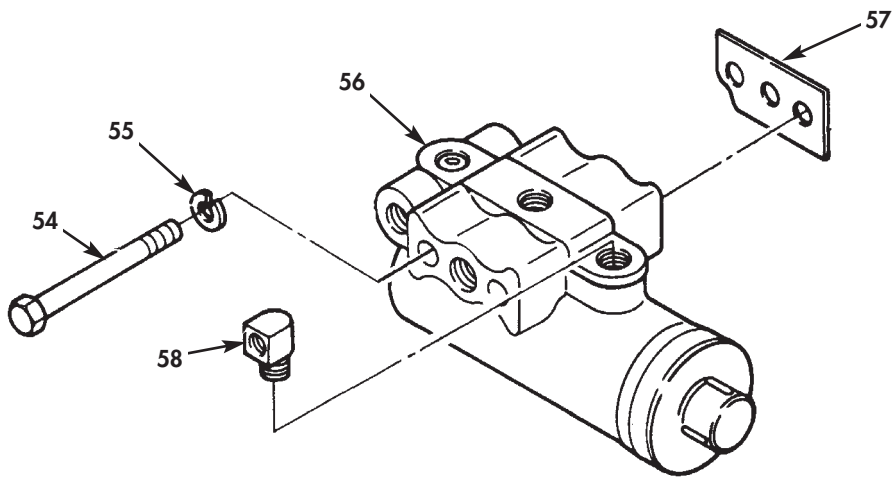


Figure 20. Air Compressor and Governor Assembly (Sheet 2 of 2).

(1) ITEM NO	(2) SMR CODE	(3) NSN	(4) CAGEC	(5) PART NUMBER	(6) DESCRIPTION AND USABLE ON CODE(UOC)	(7) QTY
GROUP 0121 COMPRESSOR ASSEMBLY						
FIG. 20 AIR COMPRESSOR AND GOVERNOR ASSEMBLY						
1	PAFZZ	5310-00-011-6122	12204	116122	WASHER, LOCK	4
2	PAFZZ	5305-01-147-4034	15434	S-122-C	SCREW, CAP, HEXAGON H	2
3	PAFZZ	5305-00-071-2056	80204	B1821BH044C175N	SCREW, CAP, HEXAGON H	2
4	PAFZZ	3010-01-079-3461	15434	199349	COUPLING, SHAFT, RIGI	1
5	PAFZZ	5330-01-181-0631	15434	320-1850	GASKET	1
6	PAFZZ	5310-01-112-4307	15434	69324	WASHER, FLAT	2
7	PAFZZ	5310-00-650-0187	15434	S-217	NUT, PLAIN, HEXAGON	2
8	PAFFD	4310-01-141-0879	15434	3024365	COMPRESSOR, RECIPROC	1
9	PAFZZ	5305-00-225-8507	80205	MS90725-43	.SCREW, CAP, HEXAGON H	4
10	PAOZZ	5310-00-407-9566	96906	MS35338-45	.WASHER, LOCK	2
11	PAOZZ	5310-00-562-6558	15434	S-626	.WASHER, FLAT	2
12	PAFZZ	4310-01-146-5921	15434	153964	.COVER, AIR COMPRESSO	1
13	PAFZZ	5330-00-131-7072	15434	3047159	.GASKET	1
14	PAFZZ	4310-01-146-1097	15434	218793	.CYLINDER HEAD, COMPR	1
15	PAFZZ	5330-00-852-7347	15434	154018	.GASKET	1
16	AFFFF		15434	3018488	.PISTON, COMPRESSOR	1
17	KFFZZ		15434	650330	..RING, PISTON PART OF KIT P/N AR- 73350	1
18	KFFZZ		15434	1875350	..RING, COMPRESSION, PART OF KIT P/N AR-73350	1
19	KFFZZ		15434	180810	..RING, PISTON PART OF KIT P/N AR- 73350	1
20	PAFZZ	4310-01-271-5103	15434	3045670	..PISTON, COMPRESSOR	1
21	PAFZZ	5325-00-922-9101	15434	119859	..RING, RETAINING	2
22	PAFZZ	4310-00-903-7174	15434	11981000	..PIN, PISTON	1
23	PAFZZ	2815-00-369-7846	15434	3558655	..CONNECTING ROD, PIST	1
24	PAFZZ	3120-01-146-7196	15434	3018153	..BUSHING, SLEEVE	1
25	PAFZZ	4310-01-079-3319	15434	3558653	..HOUSING, AIR COMPRES	1
26	PAFZZ	3120-01-016-4883	15434	147610	..BEARING, SLEEVE	1
27	PAFZZ	9905-00-473-7260	15434	136403	..PLATE, MARKING, BLANK	1
28	PAFZZ	5305-00-804-6318	15434	S-2286	..SCREW	2
29	PAFZZ	4310-01-079-3383	15434	AR1092200	..CRANKSHAFT, COMPRESS	1
30	PAFZZ	4730-00-964-7548	21450	444683	..PLUG, PIPE	1
31	PAFZZ	5305-01-145-8359	15434	3019573	.SCREW, ASSEMBLED WAS	2
32	PAFZZ	5330-00-129-9389	15434	176027	.GASKET	1
33	PAFZZ	5310-00-209-0965	96906	MS35338-47	.WASHER, LOCK	4
34	PAFZZ	5305-01-129-4384	15434	3015282	.SCREW, CAP, HEXAGON H	4
35	PAFZZ	3010-01-085-2732	15434	3000174	.COUPLING HALF, SHAFT	1
36	PAFZZ	3120-01-129-7659	15434	211662	.BEARING, WASHER, THRU	1
37	PAFZZ	2530-01-130-2339	15434	3005152	.SUPPORT, AIR COMPRES	1
38	PAFZZ	5365-00-369-4729	15434	183429	.SHIM	1
39	PAFZZ	5360-00-895-3216	15434	128080	.SPRING, HELICAL, COMP EXHAUST VALVE	1
40	PAFZZ	4820-00-445-0610	15434	127940	.DISK, VALVE	1
41	PCFZZ	5331-00-905-2679	15434	128085	.O-RING EXHAUST VALVE	1
42	PAFZZ	4820-00-909-4174	15434	144714	.SEAT, VALVE	1
43	PCFZZ	5330-01-060-9061	15434	211315	.PACKING, PREFORMED	1
44	PAFZZ	5360-00-129-9415	15434	190334	.SPRING, HELICAL, COMP INTAKE VALVE	1
45	PAFZZ	3805-00-955-5320	15434	144948	.VALVE INTAKE COMPRES	1
46	PAFZZ	4820-00-909-4175	15434	145028	.SEAT, VALVE	1
47	PAFZZ	5360-01-086-3480	15434	3023101	.SPRING, HELICAL, COMP UNLOADER VALVE	1
48	PAFZZ	4310-01-084-7148	8X479	191037	.CAP, UNLOADER	1
49	PAFZZ	5331-00-941-3762	15434	127936	.O-RING	1
50	PCFZZ	5331-00-441-0145	15434	128086	.O-RING UNLOADER VALVE	1
51	PAFZZ	4310-01-146-4155	15434	3046298	.BODY, UNLOADING VALV UNLOADER VALVE	1
52	PAFZZ	5310-01-056-1371	1ML14	14978	.WASHER, FLAT	2

(1) ITEM NO	(2) SMR CODE	(3) NSN	(4) CAGEC	(5) PART NUMBER	(6) DESCRIPTION AND USABLE ON CODE(UOC)	(7) QTY
53	PAFZZ	5305-01-144-6233	15434	3021470	.SCREW,CAP,HEXAGON H WITH CAPTIVE WASHER, 5/16.....	2
54	PAFZZ	5305-01-118-4285	24617	9418993	SCREW,CAP,HEXAGON H.....	2
55	PAFZZ	5310-01-097-8039	24617	9417953	WASHER,LOCK.....	2
56	PAFFZ	2530-00-827-5934	06853	275707	GOVERNOR ASSEMBLY,A.....	1
57	PCFZZ	5330-01-097-7791	06853	237303	GASKET.....	1
58	PAFZZ	4730-00-277-8269	79470	400X3	ELBOW,PIPE TO TUBE.....	1

END OF FIGURE

4 — 5
thru
18

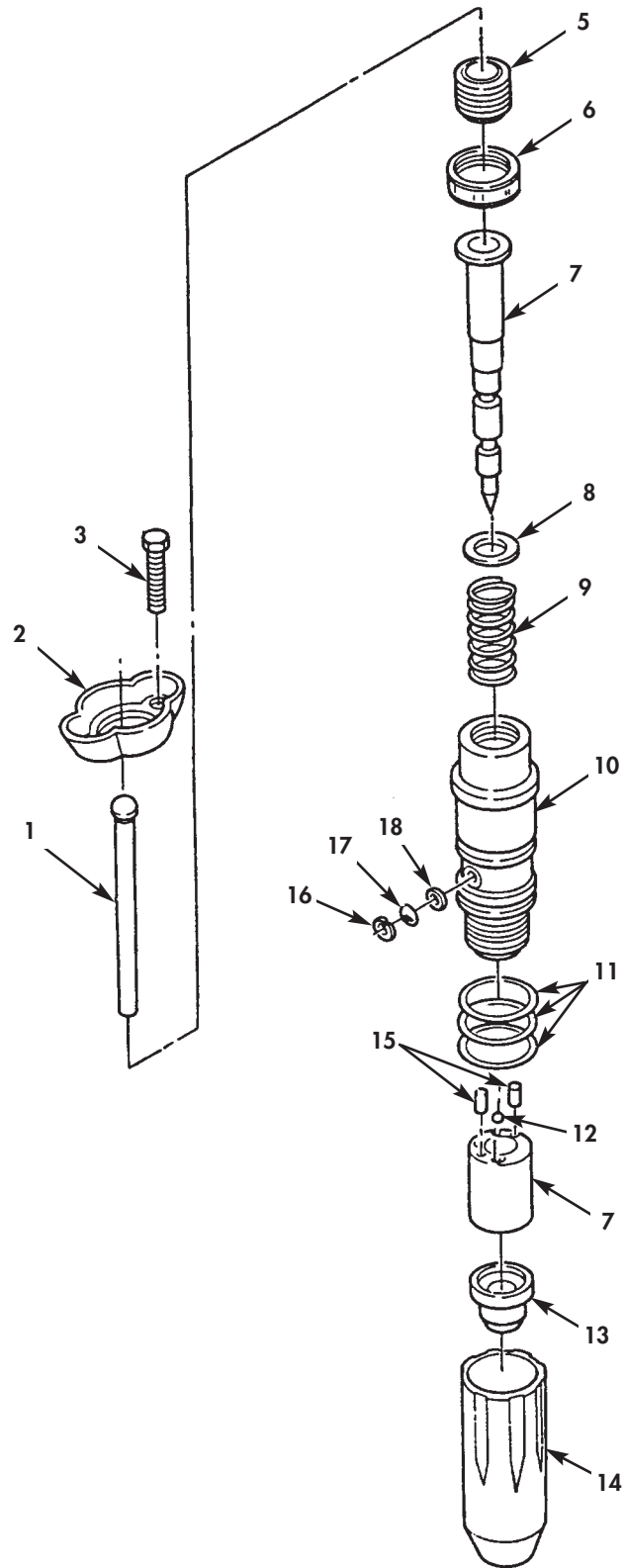


Figure 21. Fuel Injector.

(1) ITEM NO	(2) SMR CODE	(3) NSN	(4) CAGEC	(5) PART NUMBER	(6) DESCRIPTION AND USABLE ON CODE(UOC)	(7) QTY
					GROUP 03 FUEL GROUP 0301 CARBUREATOR, FUEL INJECTOR	
					FIG. 21 FUEL INJECTOR	
1	PAFZZ	5340-00-238-5435	15434	191916	PLUNGER,DETENT.....	6
2	PAFZZ	3040-01-077-4976	15434	3003682	PLATE,RETAINING,SHA INJECTOR TO CYLINDER HEAD,INJECTOR,FUEL,BIG CAM I.....	6
2	PAFZZ	5342-01-145-0646	15434	3028171	CLAMP BIG CAM III.....	6
3	PAFZZ	5305-01-086-7285	15434	202069	SCREW,CAP,SOCKET HE INJECTOR TO CYLINDER HEAD,INJECTOR,FUEL,BIG CAM I.....	12
3	PAFZZ	5305-01-145-0777	15434	3028279	SCREW,CAP,HEXAGON H INJECTOR CLAMP,BIG CAM III.....	12
4	PAFHH	2910-01-112-7712	15434	3054071	INJECTOR ASSEMBLY,F BIG CAM I.....	6
4	PAFHH	2910-01-145-9403	15434	3047973	NOZZLE,FUEL INJECTI BIG CAM III....	6
5	PAHZZ	5305-01-079-7028	15434	212954	.SCREW.....	1
6	PAHZZ	5310-01-079-6708	15434	3000465	.NUT,PLAIN,DODECAGON.....	1
7	PAHZZ	5340-01-145-0647	15434	3047963	.PLUNGER,QUICK RELEA.....	1
8	PAHZZ	5310-01-079-6529	15434	208525	.WASHER,SHOULDERED A BIG CAM I.....	1
8	PAHZZ	5310-01-145-1114	15434	3015469	.WASHER BIG CAM III.....	1
9	PAHZZ	5360-00-132-0245	15434	166009	.SPRING,HELICAL,COMP.....	1
10	PAHZZ	2910-01-076-8632	15434	3000464	.ADAPTER,INJECTOR.....	1
11	PCHZZ	5330-00-132-0276	15434	193736	.GASKET PART OF KIT P/N 4024958 PART OF KIT P/N 3804280.....	3
12	PAHZZ	4820-01-070-9710	15434	167157	.BALL CHECK,FUEL INJ.....	1
13	PAHZZ	2910-01-086-3974	15434	3012538	.CUP,INJECTOR INJECTOR,FUEL,BIG CAM I.....	1
13	PAHZZ	2910-01-146-1998	15434	3023556	.CUP,INJECTOR,FUEL BIG CAM III.....	1
14	PAHZZ	5342-01-079-4678	15434	185138	.RETAINER,CUP.....	1
15	PAHZZ	5315-01-079-6506	15434	203426	.PIN,SPRING.....	2
16	PAHZZ	5325-00-815-1137	15434	174299	.RING,RETAINING.....	1
17	PAHZZ	4730-01-077-2016	15434	3008706	.STRAINER ELEMENT,SE.....	1
18	PCHZZ	5330-00-132-0247	15434	173086	.GASKET.....	1

END OF FIGURE

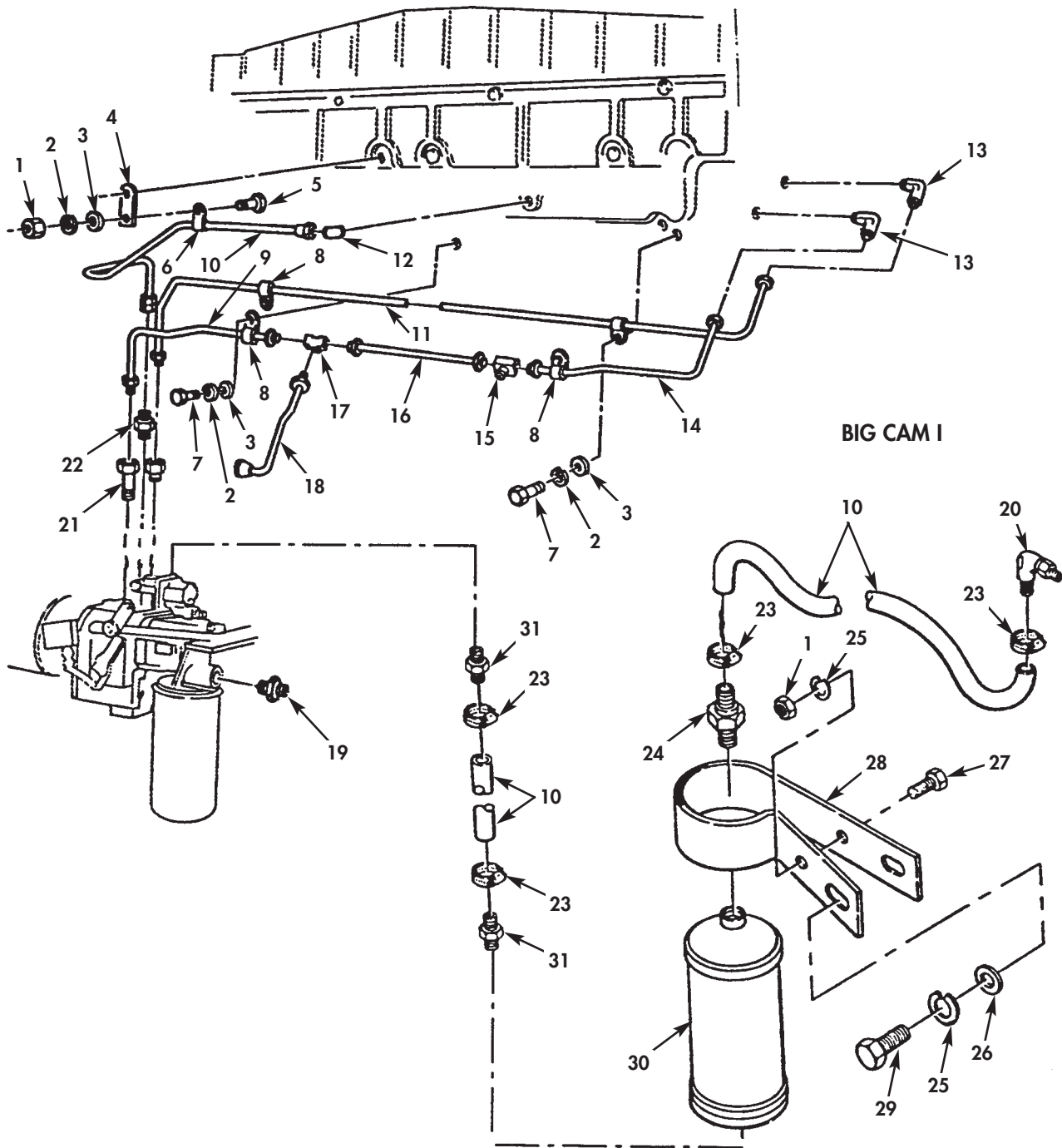


Figure 22. Fuel Lines and Fittings.

(1) ITEM NO	(2) SMR CODE	(3) NSN	(4) CAGEC	(5) PART NUMBER	(6) DESCRIPTION AND USABLE ON CODE(UOC)	(7) QTY
GROUP 0302 FUEL PUMP						
FIG. 22 FUEL LINES AND FITTINGS						
1	PAOZZ	5310-00-521-8595	15434	S-223	NUT,HEXAGON.....	2
2	PAFZZ	5310-00-159-6209	96906	MS122032	WASHER,LOCK DAMPER TO GEAR	2
MOTOR,DAMPER,FUEL FILTER BIG CAM I..						
2	PAOZZ	5310-00-261-7340	15434	S-604	WASHER,LOCK BIG CAM III.....	3
3	PAOZZ	5310-00-562-6560	15434	S631	WASHER,FLAT BIG CAM I.....	4
3	PAOZZ	5310-00-486-2505	15434	108330	WASHER,FLAT BIG CAM III.....	3
4	PFOZZ	5342-00-858-3507	15434	147135	BRACKET,TUBE SUPPOR.....	1
5	PAOZZ	5305-01-029-1193	15434	S-117	SCREW 3/8-16 X 3/4.....	1
6	PAOZZ	5340-01-079-8097	15434	180371	CLAMP,LOOP.....	2
7	PAOZZ	5306-01-204-3297	15434	137796	BOLT,MACHINE BIG CAM I.....	1
7	PAOZZ	5305-00-795-9345	15434	S190C	SCREW,CAP 3/8-24 X 5/8 BIG CAM III.	2
8	PAOZZ	5340-00-719-4601	15434	180372	CLAMP,LOOP.....	3
9	PBOZZ	4710-01-085-9348	15434	3015373	TUBE ASSEMBLY,METAL BIG CAM I.....	1
9	PAOZZ	4710-01-146-3779	15434	3022821	TUBE ASSEMBLY,METAL BIG CAM III....	1
10	MOOZZ		19207	5414243-20	HOSE,NONMETALLIC BIG CAM I , MAKE	2
FROM P/N 28430.....						
10	PAOZZ	4710-01-146-1115	15434	3038037	TUBE ASSEMBLY,METAL BIG CAM III....	1
11	PBOZZ	4710-01-079-3493	15434	216128	TUBE ASSEMBLY,METAL BIG CAM I.....	1
11	PAOZZ	4710-01-146-1114	15434	202185	TUBE ASSEMBLY,METAL BIG CAM III....	1
12	PAOZZ	4730-01-131-4884	15434	S00109700	ADAPTER,STRAIGHT,PI WITH ADAPTER	1
AND PLUG.....						
13	PAOZZ	4730-00-444-1710	15434	181213	ELBOW,PIPE TO TUBE.....	2
14	PAOZZ	4710-01-146-1116	15434	3013161	TUBE ASSEMBLY,METAL BIG CAM III....	1
15	PAOZZ	4730-01-146-3633	15434	301439800	TEE,TUBE.....	1
16	PBOZZ	4710-01-085-6134	15434	3015393	TUBE ASSEMBLY,METAL BIG CAM I.....	1
16	PAOZZ	4710-01-146-1113	15434	3015389	TUBE ASSEMBLY,METAL BIG CAM III....	1
17	PAOZZ	4730-01-109-8501	15434	301439700	TEE,TUBE.....	1
18	PAOZZ	4710-01-085-9349	15434	3015375	TUBE ASSEMBLY,METAL BIG CAM I.....	1
18	PAOZZ	4710-01-146-3169	15434	3015387	TUBE ASSEMBLY,METAL BIG CAM III....	1
19	PAOZZ	4730-01-106-4700	15434	129866	ADAPTER,STRAIGHT,TU.....	1
20	PAOZZ	4730-01-142-8524	15434	68139	ELBOW,PIPE TO TUBE.....	1
21	PAOZZ	2910-01-146-0093	15434	3020760	VALVE.....	1
22	PAOZZ	4730-01-146-3040	15434	3018889	ADAPTER,STRAIGHT,PI.....	1
23	PAOZZ	4730-00-278-9200	88044	AN737TW22	CLAMP,HOSE PART OF KIT	4
P/N 302112400.....						
24	KFOZZ		15434	3020754	BODY,CHECK VALVE PART OF KIT	1
P/N 302112400.....						
25	PAOZZ	5310-00-637-9541	96906	MS35338-46	WASHER,LOCK PART OF KIT	1
P/N 302112400.....						
26	KFOZZ		15434	S689	WASHER,PLAIN BIG CAM I PART OF KIT	1
P/N 302112400.....						
27	KFOZZ		15434	S-109	SCREW,CAP,HEXAGON BIG CAM I PART	1
OF KIT P/N 302112400.....						
28	KFOZZ		15434	170970	CLAMP BIG CAM I PART OF KIT	1
P/N 302112400.....						
29	KFOZZ		15434	S-151C	SCREW,CAP,HEXAGON BIG CAM I PART	1
OF KIT P/N 302112400.....						
30	KFOZZ		15434	3020753	TANK,AIR BIG CAM I PART OF KIT	1
P/N 302112400.....						
31	PAOZZ	4730-00-900-3296	72983	248X4	ADAPTER,STRAIGHT,PI PART OF KIT	2
P/N 302112400.....						

END OF FIGURE

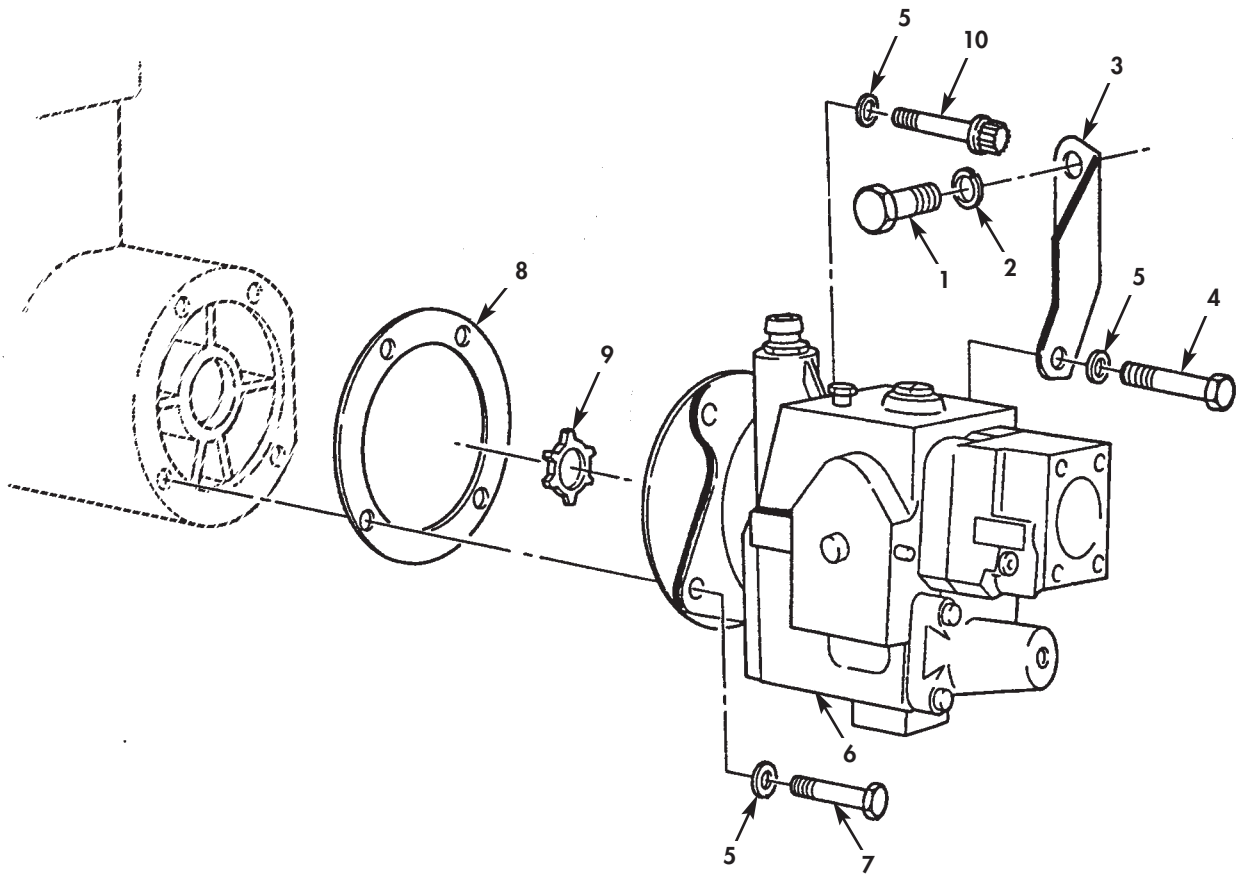
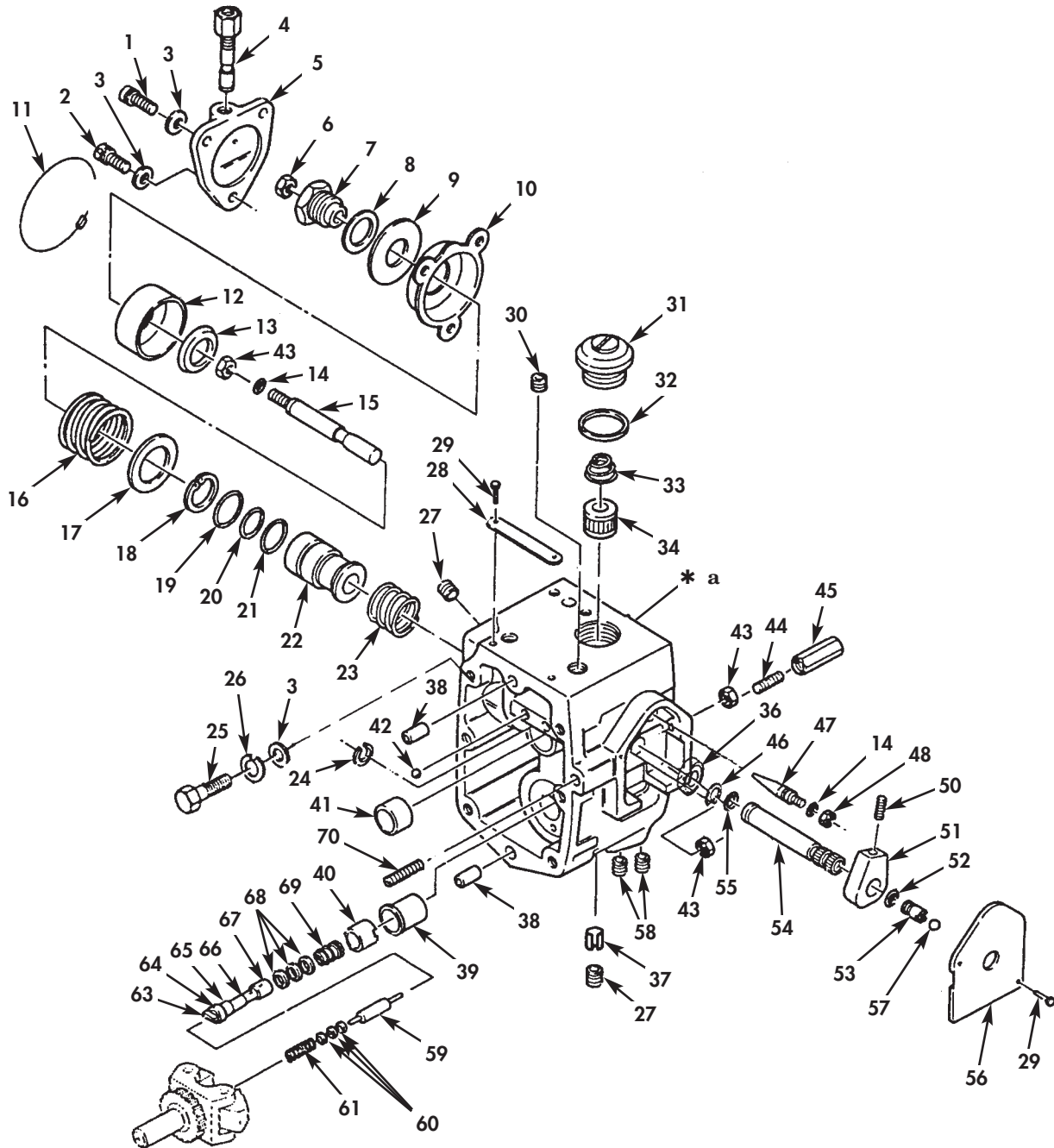
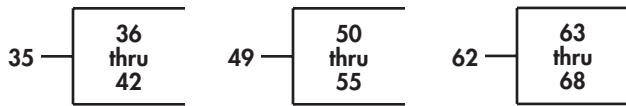


Figure 23. Fuel Pump.

(1) ITEM NO	(2) SMR CODE	(3) NSN	(4) CAGEC	(5) PART NUMBER	(6) DESCRIPTION AND USABLE ON CODE(UOC)	(7) QTY
GROUP 0302 FUEL PUMP						
FIG. 23 FUEL PUMP						
1	PAFZZ	5305-01-147-4034	15434	S-122-C	SCREW,CAP,HEXAGON H 9/16-18 X 7/8..	1
2	PAFZZ	5310-00-011-6122	12204	116122	WASHER,LOCK.....	1
3	PFHZZ	5342-01-085-4153	15434	3001296	BRACKET,AIR COMPRES.....	1
4	PAFZZ	5305-01-147-8732	15434	3012481	SCREW,CAP,HEXAGON H 7/16-14 X 1	1
					1/2,BIG CAM III.....	
5	PAFZZ	5310-01-112-4307	15434	69324	WASHER,FLAT.....	4
6	PAFHH	2910-01-141-9372	15434	3060202-3894	PUMP,FUEL,METERING "BUSHED GEAR." CAN BE USED W/ALL DIESEL FUELS. BIG CAM III.....	1
6	PAFHH	2910-01-065-3979	15434	FC3619RX	PUMP,FUEL,ENGINE "NON-BUSHED GEAR" BIG CAM I.....	1
7	PAFZZ	5305-01-145-0777	15434	3028279	SCREW,CAP,HEXAGON H BIG CAM III....	1
7	PAFZZ	5305-01-129-4384	15434	3015282	SCREW,CAP,HEXAGON H BIG CAM I.....	2
8	PAHZZ	5330-01-160-7460	15434	3035053	GASKET.....	1
9	PAFZZ	3010-00-447-9799	15434	162426	INSERT,FLEXIBLE COU FUEL PUMP TO AIR COMPRESSOR.....	1
10	PAHZZ	5305-01-113-1179	15434	206326	SCREW,CAP,HEXAGON H 7/16-14 X 1 1/4	1
END OF FIGURE						



* a PART OF ITEM 35

Figure 24. Fuel Pump Main Housing.

(1) ITEM NO	(2) SMR CODE	(3) NSN	(4) CAGEC	(5) PART NUMBER	(6) DESCRIPTION AND USABLE ON CODE(UOC)	(7) QTY
GROUP 0302 FUEL PUMP						
FIG. 24 FUEL PUMP MAIN HOUSING						
1	PAHZZ	5305-01-129-4385	15434	70772-B	SCREW,CAP,HEXAGON H FILSTER HEAD, 1/4-20 X 1.00.....	2
2	PAHZZ	5305-01-129-4218	15434	3012558	SCREW DRILLED FILSTER HEAD, 1/4-20 X 1.00.....	1
3	PAHZZ	5310-00-562-6560	15434	S-631	WASHER,FLAT.....	3
4	PAHZZ	4820-01-079-3241	15434	301552200	CARTRIDGE,VALVE,CHE.....	1
5	PAHZZ	2910-01-141-4967	15434	301552000	COVER,FUEL CONTROL.....	1
6	PAHZZ	5310-00-451-6643	15434	S-213-A	NUT,FLYWHEEL.....	1
7	PAHZZ	2910-01-141-4029	15434	302317100	HOUSING,SPRING PUMP.....	1
8	PAHZZ	5330-01-142-2784	15434	3023870	GASKET BIG CAM III PART OF KIT P/N 3010242.....	1
9	PAHZZ	5310-01-145-0761	15434	214150	WASHER,FLAT.....	1
10	PAHZZ	4820-01-079-3320	15434	3013811	DIAPHRAGM,VALVE.....	1
11	PAHZZ	5330-01-072-8830	15434	3003156	SEAL,SPECIAL PART OF KIT P/N 3010242.....	1
12	PAHZZ	2910-01-142-7455	15434	301381000	PISTON,AIR FLOW.....	1
13	PAHZZ	5310-01-142-2812	15434	3023088	WASHER,FLAT.....	1
14	PCHZZ	5331-00-970-3461	15434	68061-A	O-RING PART OF KIT P/N 3010242.....	2
15	PAHZZ	2910-01-126-9053	15434	3021676	PLUNGER,AIR FLOW.....	1
16	PAHZZ	5360-01-086-6113	15434	179834	SPRING,HELICAL,COMP BIG CAM I.....	1
16	PAHZZ	5360-01-147-0054	15434	179822	SPRING,HELICAL,COMP BIG CAM III....	1
17	PAHZZ	5365-01-079-8373	15434	3001707	SHIM.....	1
18	PAHZZ	5325-00-558-9412	96906	MS16629-1100	RING,RETAINING.....	1
19	PAHZZ		15434	145505	PACKING,PREFORMED PART OF KIT P/N 3010242.....	1
20	PCHZZ	5330-01-051-4243	15434	145504	PACKING,PREFORMED PART OF KIT P/N 3010242.....	1
21	PCHZZ	5330-00-403-9896	15434	193734	PACKING,PREFORMED BIG CAM I.....	1
21	PAHZZ	5330-00-599-2962	94135	12Z9026-5	PACKING,PREFORMED BIG CAM III.....	1
22	PAHZZ	3040-01-086-1651	15434	214146	CYLINDER,ACTUATING,.....	1
22	PAHZZ	2910-01-142-4953	15434	3021068	BARREL,AIR FLOW.....	1
23	PAHZZ	5360-01-134-5602	15434	3018655	SPRING,HELICAL,COMP.....	1
24	PAHZZ	5325-00-256-2846	96906	MS16632-1050	RING,RETAINING.....	1
25	XDFZZ		15434	S105X	SCREW,CAP.....	6
26	PAFZZ	5310-00-484-1718	15434	181466	WASHER,LOCK.....	8
27	PAFZZ	4730-01-124-3762	15434	3025460	PLUG,PIPE.....	5
28	PFHZZ	9905-00-733-7622	15434	105375	PLATE,IDENTIFICATIO.....	1
29	PFHZZ	5305-00-804-6318	15434	S-2286	SCREW.....	4
30	PAFZZ	4730-00-042-8988	7X677	117244	PLUG,PIPE BIG CAM I.....	1
30	PAHZZ	4730-00-555-8292	10001	12Z329PC92	PLUG,PIPE BIG CAM III.....	1
31	PAOZZ	5365-00-507-3271	15434	157088	PLUG,MACHINE THREAD.....	1
32	PCHZZ	5330-00-961-9470	15434	154088	GASKET PART OF KIT P/N 3010242.....	1
33	PAOZZ	5360-00-597-4570	15434	70700	SPRING,HELICAL,COMP BIG CAM III....	1
34	PAOZZ	2910-00-790-8736	15434	14648300	FILTER ELEMENT,FLUI.....	1
35	XDHZZ	2910-01-086-3983	15434	AR41022	HOUSING,FUEL PUMP BIG CAM I.....	1
35	PAHZZ	2910-01-146-1084	15434	3010042	BARREL,GOVERNOR BIG CAM III.....	1
36	PAHZZ	3120-01-080-3275	15434	209760	.BUSHING,SLEEVE.....	1
37	PAHZZ	5342-00-400-5178	15434	163733	.CLIP,GOVERNOR BARRE.....	1
38	PAHZZ	5315-00-844-0140	15434	118227	.PIN,HOLLOW.....	4
39	PAHZZ	2910-01-098-5118	15434	217798	.HOUSING,SPRING PACK.....	1
40	PAHZZ	2910-01-147-9913	15434	3001847	.BARREL ASSEMBLY,GOV.....	1
41	PAHZZ	3120-00-810-6032	15434	100193	.BEARING,SLEEVE TACHOMETER DRIVE...	1
42	PAHZZ	2910-01-141-4028	15434	21413900	.BALL,PLUG BRASS.....	2
43	PAHZZ	5310-00-971-7989	96906	MS35691-5	NUT,PLAIN,HEXAGON.....	3
44	PAHZZ	5340-00-716-4975	15434	110058	POST,ELECTRICAL-MEC.....	1

(1) ITEM NO	(2) SMR CODE	(3) NSN	(4) CAGEC	(5) PART NUMBER	(6) DESCRIPTION AND USABLE ON CODE(UOC)	(7) QTY
45	PAHZZ	5305-01-109-9307	15434	195755	SCREW.....	1
46	PAHZZ	5325-00-256-2846	96906	MS16632-1050	RING,RETAINING.....	1
47	PAHZZ	2910-01-091-7507	15434	214144	VALVE,NEEDLE CARBUR.....	1
48	PFHZZ	5310-00-005-6052	15434	S248	NUT,PLAIN,HEXAGON.....	1
49	PAHZZ	2910-01-080-3149	15434	AR41010	SHAFT ASSEMBLY,THRO.....	1
50	PFHZZ	5305-01-135-5446	15434	3006344	.SETSCREW 1/4-28UNF-3A.....	1
51	PFHZZ	3040-01-086-1449	15434	3006343	.END,CONTROL R.....	1
52	PCHZZ	5331-01-072-8983	15434	213768	.O-RING PART OF KIT P/N 3010242....	1
53	PFHZZ	5305-01-072-8826	15434	3076040	.SCREW FUEL ADJUSTING.....	1
54	PAHZZ	3040-01-241-4696	15434	3046680	.SHAFT,SHOULDERED.....	1
55	PAHZZ	5331-00-081-9289	15434	100478	.O-RING.....	1
56	PAHZZ	4320-01-098-5115	15434	3000446	COVER.....	1
57	PAHZZ	3110-01-079-8190	15434	213769	BALL,BEARING.....	1
58	PAHZ	4730-01-078-6364	15434	20063500	PLUG,PIPE BIG CAM I.....	2
59	PAHZZ	5315-00-082-0448	15434	144178	PIN,SHOULDER,HEADLE BIG CAM III....	1
60	PAHZZ	5310-00-086 7859	15434	144179	WASHER,FLAT BIG CAM III.....	3
61	PAHZZ	5360-01-095-3661	15434	143848	SPRING,HELICAL,COMP BIG CAM III....	1
62	PFHZZ	2910-01-070-9712	15434	3039070	PLUNGER ASSEMBLY,GO BIG CAM I.....	1
62	PAHZZ	5342-01-145-1549	15434	3010810	PLUNGER BIG CAM III.....	1
63	PAHZZ	2990-00-772-1778	15434	70690	.DRIVER,PLUNGER,GOVE.....	1
64	PAHZZ	3120-01-160-7482	15434	3027633	.BEARING,SLEEVE BIG CAM I.....	1
65	PAHZZ	5365-00-829-5604	15434	144302	.SPACER,FUEL PUMP BIG CAM III.....	1
66	PAHZZ	5315-00-907-0711	72962	590220940406	.PIN,SPRING BIG CAM I.....	1
67	PAHZZ	2910-01-080-5570	15434	20335000	.PLUNGER,GOVERNOR BIG CAM I.....	1
67	PAHZZ	2910-01-136-3331	15434	300938000	.PLUNGER,GOVERNOR BIG CAM III.....	1
68	PAHZZ	5365-00-507-3224	15434	101841	.SHIM BIG CAM I..... V	
68	PAHZZ	5365-00-507-3225	15434	101842	.SHIM BIG CAM I..... V	
68	PAHZZ	5365-00-543-3744	15434	101843	.SPACER,RING BIG CAM I..... V	
68	XDHZZ		15434	3026733	.SHIM BIG CAM III..... V	
69	PAHZZ	5360-01-086-6114	15434	138769	SPRING,HELICAL,COMP BIG CAM I.....	1
69	PAHZZ	5360-01-138-6638	15434	138781	SPRING,HELICAL,COMP BIG CAM III....	1
70	PAHZZ	5305-00-063-5043	88044	AN565F428H24	SETSCREW.....	1

END OF FIGURE

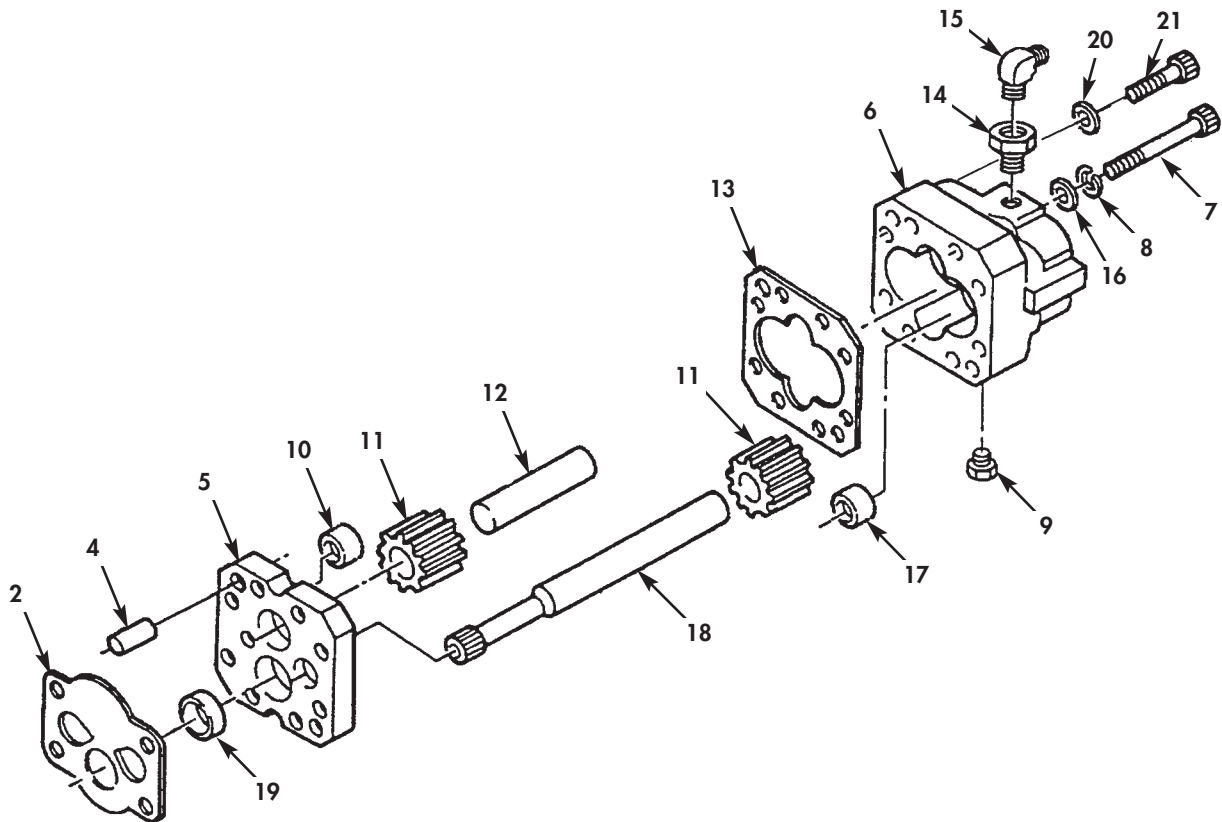
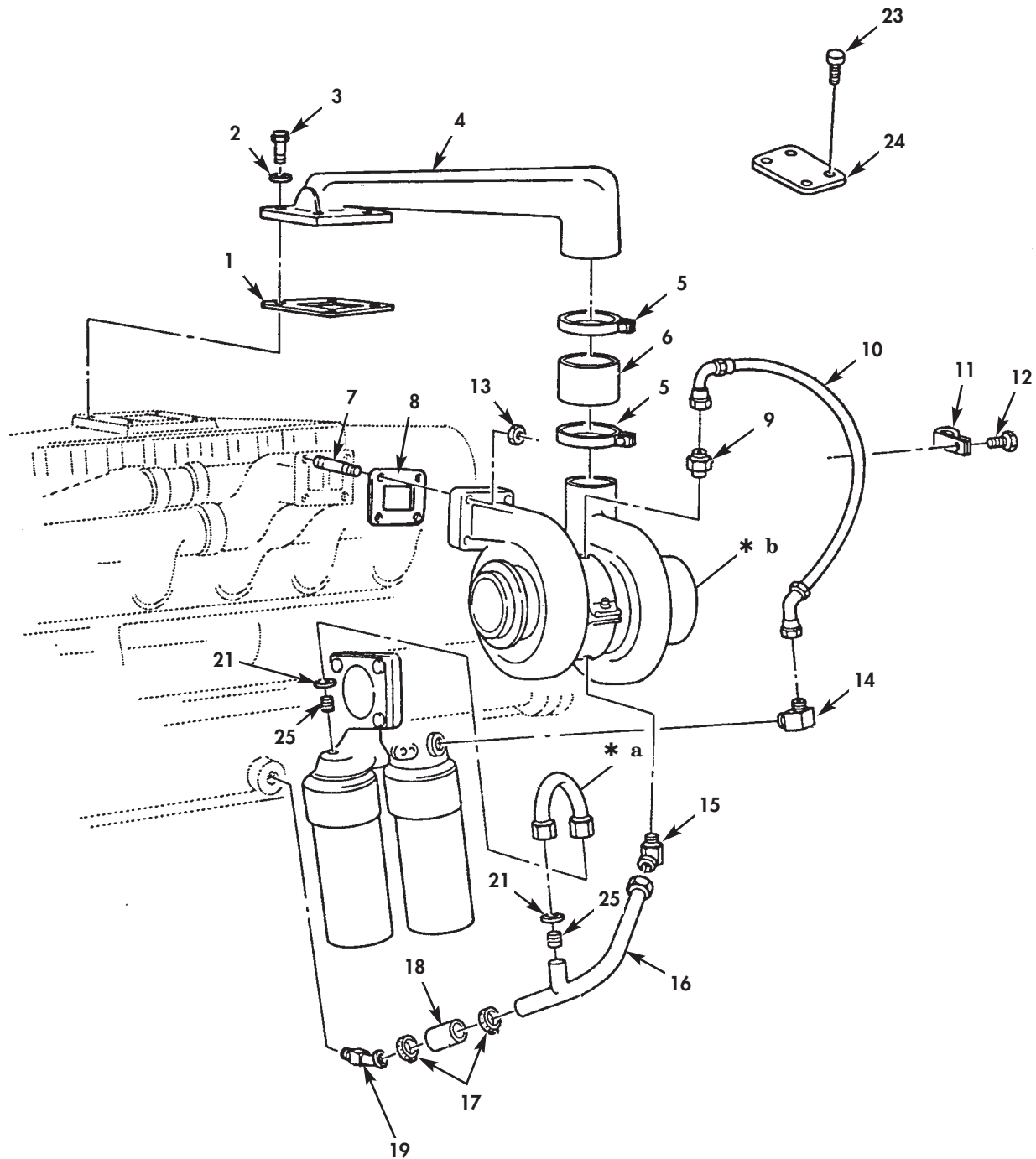


Figure 25. Fuel Gear Pump.

(1) ITEM NO	(2) SMR CODE	(3) NSN	(4) CAGEC	(5) PART NUMBER	(6) DESCRIPTION AND USABLE ON CODE(UOC)	(7) QTY
GROUP 0302 FUEL PUMP						
FIG. 25 FUEL GEAR PUMP						
1	PAFHD	2815-01-291-5753	15434	3034243	PUMP,FUEL GEAR "BUSHED." CAN BE USED W/ALL DIESEL FUELS.....	1
2	PCHZZ	5330-00-567-3463	15434	110855	.GASKET PART OF KIT P/N 3010242....	1
3	PAHZZ	2910-01-096-9200	15434	BM97497	.HOUSING ASSEMBLY,FU.....	1
4	PAHZZ	5315-00-014-1244	24617	141244	..PIN,STRAIGHT,HEADLE.....	2
5	XAHZZ		15434	175867	..COVER.....	1
6	XAHZZ		15434	175860	..HOUSING.....	1
7	PAHZZ	5306-00-485-0790	15434	70790	..BOLT,MACHINE.....	2
8	PAFZZ	5310-00-484-1718	15434	181466	..WASHER,LOCK.....	4
9	XDHZZ	4730-00-278-2973	88900	11920-001-00	..PLUG,PIPE.....	1
10	PAHZZ	4820-01-242-2579	15434	3050624	.VALVE,REGULATING,FL.....	1
11	PAHZZ	3020-00-702-3882	15434	11936300	.GEAR,SPUR.....	2
12	PAHZZ	3040-00-933-3012	15434	17586400	.IDLER,SHAFT.....	1
13	PCHZZ	5330-01-136-8569	15434	3069017	.GASKET PART OF KIT P/N 3010242....	1
14	XDHZZ		15434	3045049	.PLUG.....	1
15	PAHZZ	4820-01-164-7002	15434	3033740	.VALVE,CHECK.....	1
16	PAHZZ	5310-00-141-1795	88044	AN960-416	.WASHER,FLAT.....	1
17	PAHZZ	3120-01-215-9157	15434	3033724	.BEARING,SLEEVE.....	4
18	PAHZZ	3040-00-567-4354	15434	10021500	.SHAFT,SHOULDERED.....	1
19	PAHZZ	3120-01-185-8586	15434	3033719	.BUSHING,SLEEVE.....	1
20	PAHZZ	5310-00-141-1795	88044	AN960-416	WASHER,FLAT.....	4
21	PAFZZ	5305-00-721-3698	15434	100129	SCREW,CAP,SOCKET HE.....	4

END OF FIGURE



- * a PART OF ITEM 20
- * b PART OF ITEM 22

Figure 26. Turbocharger and Component Parts.

(1) ITEM NO	(2) SMR CODE	(3) NSN	(4) CAGEC	(5) PART NUMBER	(6) DESCRIPTION AND USABLE ON CODE(UOC)	(7) QTY
GROUP 0305 SUPERCHARGER, BLOWER, TURBOCHARGER, OR ALTITUDE COMPENSATOR						
FIG. 26 TURBOCHARGER AND COMPONENT PARTS						
1	PAOZZ	5330-01-072-8998	15434	216487	GASKET CROSSOVER MOUNTING, PART OF KIT P/N 4024958 PART OF KIT P/N 3804280.....	1
2	PAOZZ	5310-00-684-3463	96906	MS51092-1	WASHER,FLAT.....	4
3	PAOZZ	5305-00-068-0511	80204	B1821BH038C125N	SCREW,CAP,HEXAGON H 3/8-16 X 1 1/4.	4
4	PAOZZ	2990-01-236-2774	15434	3043984	CONNECTOR,EXHAUST P BIG CAM I.....	1
4	XDHZZ	2990-01-146-1102	15434	3018686	CONNECTOR,EXHAUST BIG CAM III.....	1
5	PAOZZ	4730-00-477-4160	63208	208326JB1	CLAMP,HOSE.....	2
6	PCOZZ	4720-01-070-8149	55683	851-202994	HOSE,PREFORMED.....	1
7	PAFZZ	5307-00-922-2626	15434	3010915	STUD,PLAIN TURBOCHARGER MOUNTING...	4
8	PAFZZ	5330-00-194-8385	15434	3069177	GASKET PART OF KIT P/N 4024958 PART OF KIT P/N 3804280.....	1
9	PAFZZ	4730-01-127-6104	15434	3014354	ADAPTER,STRAIGHT,PI.....	1
10	PCHZZ	4720-01-085-6293	15434	215195	HOSE ASSEMBLY,NONME BIG CAM I.....	1
10	PAFZZ	4720-01-146-1071	15434	209955	HOSE ASSEMBLY,NONME BIG CAM III....	1
11	PAHZZ	5340-00-400-3449	15434	108722	CLAMP,LOOP BIG CAM I.....	1
12	PAHZZ	5305-00-230-1939	15434	S118A	SCREW BIG CAM I.....	1
12	PAFZZ	5305-00-068-0502	96906	MS90725-6	SCREW,CAP,HEXAGON H WITH CAPTIVE WASHER, 1/4-20 X 3/4,BIG CAM III....	1
13	PAFZZ	5310-01-287-9737	15434	3056158	NUT,SLEEVE TURBOCHARGER MOUNTING, 3/8-24, BIG CAM III.....	4
14	PAFZZ	4730-01-146-3631	15434	302561100	ELBOW,TUBE OIL SUPPLY HOSE, BIG CAM III.....	2
15	PAFZZ	4730-01-146-7047	15434	3000560	ELBOW,PIPE TO TUBE BIG CAM III....	1
16	PAFZZ	4710-01-146-3167	15434	3035600	TUBE ASSEMBLY,METAL TURBOCHARGER DRAIN TUBE, BIG CAM III.....	1
17	PAFZZ	4730-00-555-8263	53496	5561 1-2A	CLAMP,HOSE BIG CAM III.....	2
18	PCFZZ	4720-01-006-8626	15434	AC1600300NF	HOSE,NONMETALLIC.....	1
19	PAFZZ	4730-01-079-3274	15434	300353600	ELBOW,PIPE TO HOSE TURBOCHARGER DRAIN.....	1
20	PAFZZ	4710-01-158-7507	15434	3035595	TUBE ASSEMBLY,METAL BIG CAM III....	1
21	PCFZZ	5365-00-598-5255	15434	S-1003-A	.BUSHING,NONMETALLIC.....	2
22	PFHH	2990-01-172-3005	15434	3801942	TURBOCHARGER,ENGINE BIG CAM I ONLY MODEL #NTC400.....	1
22	PAFHH	2990-01-155-7284	15434	3801904	TURBOCHARGER BIG CAM I ONLY MODEL T-50.....	1
22	PAFHH	2950-01-141-0844	15434	3803279	TURBOSUPERCHARGER,E ASSEMBLY, T46- B, BIG CAM III.....	1
23	PAHZZ	5305-00-804-6318	15434	S2286	.SCREW.....	4
24	PAHZZ	2815-00-406-6737	15434	303689200	.PLATE.....	1
25	PAFZZ	4730-00-365-2690	15434	S-1002-A	ADAPTER,STRAIGHT,TU BY-PASS FILTER TUBE.....	2

END OF FIGURE

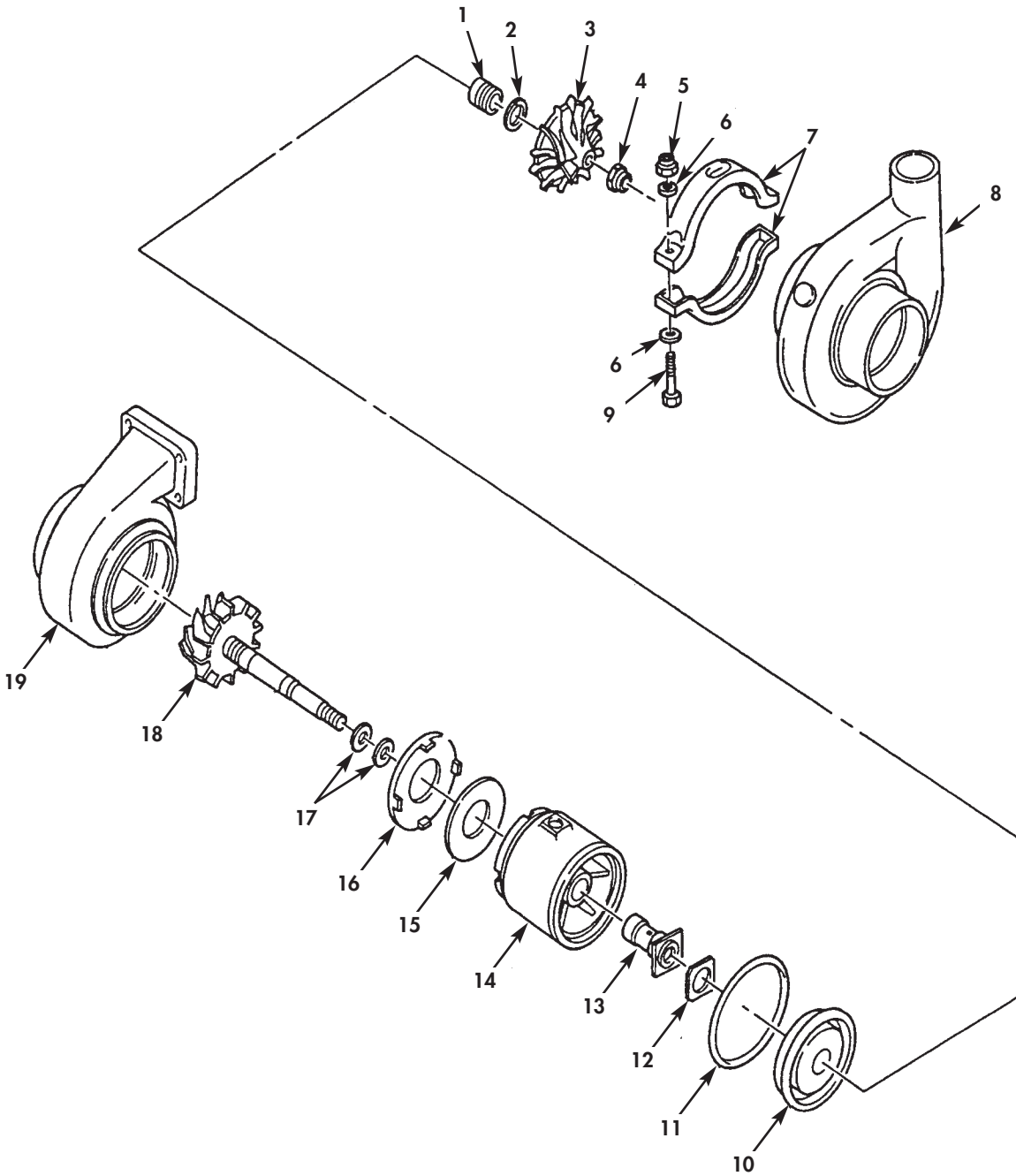


Figure 27. Turbocharger Assembly.

(1) ITEM NO	(2) SMR CODE	(3) NSN	(4) CAGEC	(5) PART NUMBER	(6) DESCRIPTION AND USABLE ON CODE(UOC)	(7) QTY
GROUP 0305 SUPERCHARGER, BLOWER, TURBOCHARGER, OR ALTITUDE COMPENSATOR						
FIG. 27 TURBOCHARGER ASSEMBLY						
1	PAHZZ	5330-01-085-3580	15434	216802	SEAL,OIL,SLEEVE	1
2	PAHZZ	5330-00-237-6266	15434	156444	SEAL,TURBO PART OF KIT P/N 3801096 .	1
3	PAHZZ	4140-01-085-2607	15434	3002731	IMPELLER,FAN,CENTRI BIG CAM I	1
3	PAHZZ	4140-01-146-1035	15434	3031980	IMPELLER,FAN,CENTRI TURBOCHARGER,BIG CAM III	1
4	XBHZZ		15434	S-222-A	NUT,SELF-LOCKING,HE	1
5	PAHZZ	5310-00-680-6874	72962	F1801-040	NUT,SELF-LOCKING,HE PART OF KIT P/N 3801096	2
6	PAHZZ	5310-00-562-6560	15434	S-631	WASHER,FLAT PART OF KIT P/N 3801096	4
7	XBHZZ		15434	156416	STRAP,RETAINING	2
8	PAHZZ	2990-01-085-4768	15434	3027308	HOUSING,COMPRESSOR BIG CAM I	1
8	XDHZZ		15434	201250	HOUSING,CENTRIFUGAL BIG CAM III	1
9	PAHZZ	5305-00-411-9340	15434	194010	SCREW,CAP,HEXAGON H HEXAGON HEAD CAP PART OF KIT P/N 3801096	2
10	PAHZZ	2990-01-085-1622	15434	21773600	PLATE,DIFFUSER VANE BIG CAM I	1
10	PAHZZ	5330-01-155-3349	15434	216804	SEAL BIG CAM III	1
11	KFHZZ		15434	202456	PACKING,PREFORMED PART OF KIT P/N 3801096	1
12	KFHZZ		15434	170510	GASKET PART OF KIT P/N 3801096	1
13	PAHZZ	3120-00-682-7706	15434	156420	BEARING,SLEEVE	1
14	PAHZZ	3130-01-294-1400	15434	3038745	HOUSING,BEARING UNI BIG CAM I	1
14	XDHZZ		15434	3026034	HOUSING,BEARING UNI BIG CAM III	1
15	KFHZZ		15434	202377	PACKING,FLAT FIBER PART OF KIT P/N 3801096	1
16	PAHZZ	2990-00-477-6159	15434	171570	SHIELD,HEAT	1
17	KFHZZ		15434	3034736	SEAL,PLAIN PART OF KIT P/N 3801096 .	2
18	PAHZZ	2835-01-086-1447	15434	214086	SHAFT,TURBINE,NONAI BIG CAM I	1
18	PAHZZ	2950-01-145-6822	15434	3032835	WHEEL AND SHAFT,IMP BIG CAM III	1
19	PAHZZ	3040-01-086-1448	15434	204244	HOUSING,MECHANICAL BIG CAM I	1
19	PFHZZ	2990-01-146-3911	15434	3026993	TURBINE HOUSING BIG CAM III	1

END OF FIGURE

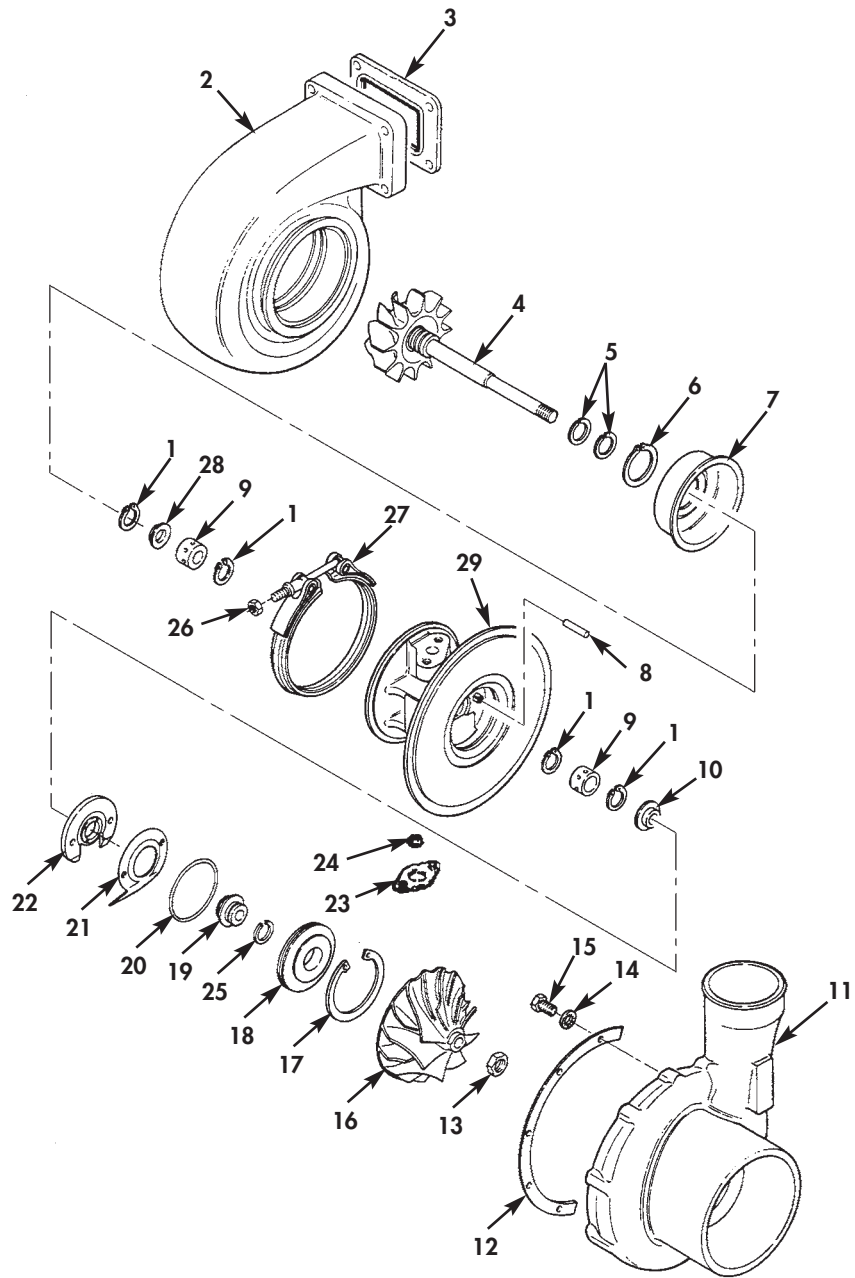


Figure 28. Turbocharger Assembly, Big Cam III.

(1) ITEM NO	(2) SMR CODE	(3) NSN	(4) CAGEC	(5) PART NUMBER	(6) DESCRIPTION AND USABLE ON CODE(UOC)	(7) QTY
					GROUP 0305 SUPERCHARGER, BLOWER, TURBOCHARGER, OR ALTITUDE COMPENSATOR	
					FIG. 28 TURBOCHARGER ASSEMBLY, BIG CAM III	
1	PAHZZ		15434	3709510	RING,RETAINING.....	4
2	PFHZZ		15434	3521837	HOUSING,TURBINE.....	1
3	PCFZZ	5330-00-194-8385	15434	3069177	GASKET.....	1
4	PAHZZ		15434	3522075	TURBINE WHEEL,TURBO.....	1
5	PAHZZ		15434	3521441	SEAL RING,METAL.....	2
6	PAHZZ	5330-01-303-1600	15434	3521442	SEAL RING,METAL.....	1
7	PAHZZ		15434	3519155	SHIELD,HEAT.....	1
8	PAHZZ		15434	3756135	PIN,STRAIGHT,HEADLE.....	2
9	PAHZZ		15434	3722366	BEARING,SLEEVE.....	2
10	PAHZZ		15434	3521440	COLLAR,THRUST.....	1
11	PAHZZ	2950-01-503-5597	15434	3529016	HOUSING,AIR COMPRES.....	1
12	PAHZZ	5340-01-497-7593	15434	3520981	PLATE,MOUNTING.....	2
13	PAHZZ	5310-01-303-8583	15434	3519471	NUT,SELF-LOCKING,HE 7/16 UNF.....	1
14	PAHZZ	5310-01-497-2856	15434	3521119	WASHER,LOCK.....	10
15	PAHZZ	5305-01-498-0704	0B8S3	3526653	SCREW,CAP,HEXAGON H 5/16-18 X 5/8...	10
16	PAHZZ	2835-01-497-7320	15434	3527047	DISK AND HUB,GAS TU.....	1
17	PAHZZ		15434	3723863	RING,RETAINING.....	1
18	PAHZZ	5330-01-497-4872	0B8S3	3759618	RETAINER,PACKING.....	1
19	PAHZZ	2815-01-497-6029	15434	3521439	DEFLECTOR,DIRT AND.....	1
20	PAHZZ		15434	3751948	O-RING.....	1
21	PAHZZ	2520-01-497-7027	15434	3519401	BAFFLE,LUBRICATING.....	1
22	PAHZZ		15434	3519290	BEARING,WASHER,THRU.....	1
23	PAHZZ	5330-01-043-4242	15434	201049	GASKET.....	1
24	PAHZZ	5331-01-344-4226	15434	3037537	O-RING.....	1
25	PAHZZ	5325-01-449-3299	15434	3718373	RING,RETAINING.....	1
26	PAHZZ	5310-01-270-8245	15434	3529372	NUT,PLAIN,HEXAGON 1/4-28 UNF.....	1
27	PAHZZ	5340-01-K72-3663	15434	3803430	CLAMP,RIM CLENCHING.....	1
28	PAHZZ		15434	3757753	BUSHING,SLEEVE.....	1
29	PAHZZ	2815-01-497-6028	15434	3522416	HOUSING,TURBO BEARI.....	1

END OF FIGURE

4 — 5
thru
17

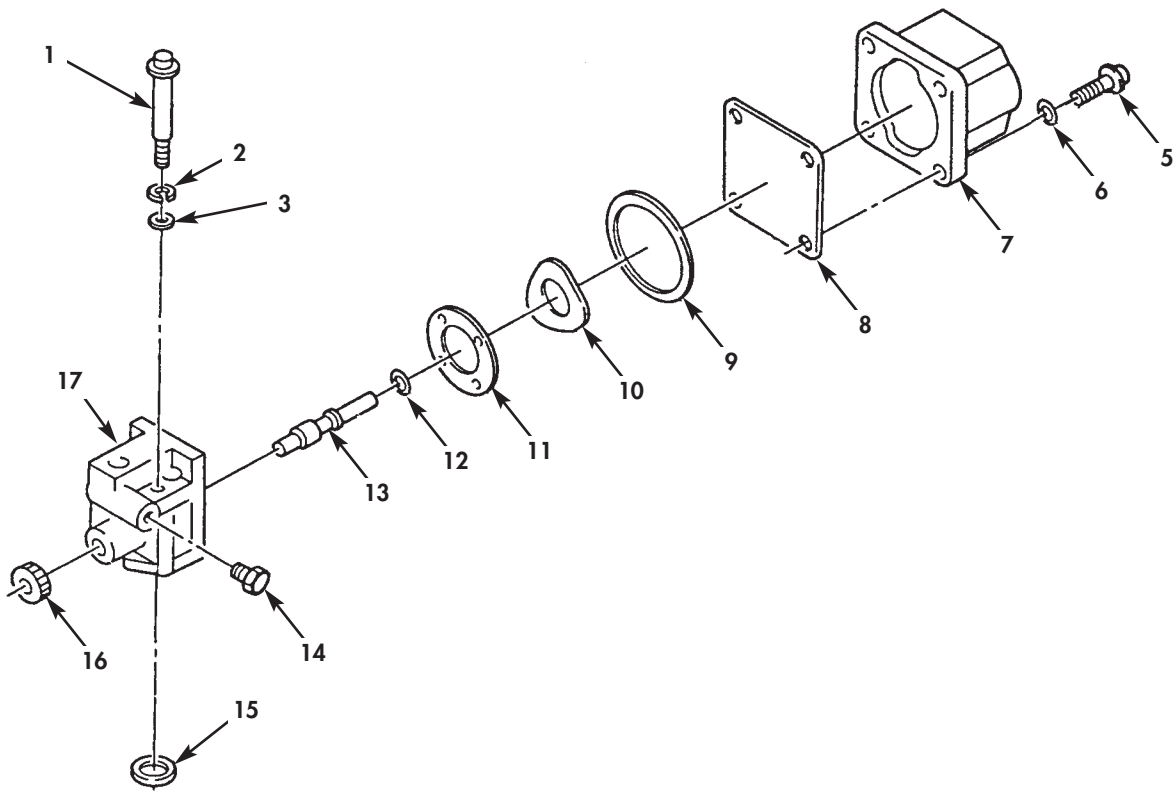


Figure 29. Solenoid Valve.

(1) ITEM NO	(2) SMR CODE	(3) NSN	(4) CAGEC	(5) PART NUMBER	(6) DESCRIPTION AND USABLE ON CODE(UOC)	(7) QTY
GROUP 0306 TANKS, LINES, FITTINGS AND HEADERS						
FIG. 29 SOLENOID VALVE						
1	PAFZZ	5305-00-509-8106	15434	S-189-C	SCREW,CAP, SOCKET HE SOCKET HEAD	2
2	PAFZZ	5310-00-484-1718	15434	181466	CAP, 1/4-20 X 1 3/4, BIG CAM III....	2
3	PAFZZ	5310-00-262-2986	15434	67684	WASHER, LOCK.....	2
4	PAOZZ	4810-01-187-4925	15434	3035362	WASHER, FLAT.....	2
5	PAFZZ	5305-00-138-9848	15434	187556	VALVE, SOLENOID.....	1
6	PAFZZ	5310-00-922-2017	30379	120217	.SCREW, MACHINE SOLENOID MOUNTING...	4
7	PAFZZ	2910-00-085-7436	15434	134074	.WASHER, LOCK.....	4
7	XDFZZ		15434	302109000	.COIL ASSEMBLY, SHUT ELECTRICAL BIG	1
8	PAFZZ	5340-00-084-7787	15434	129839	CAM III.....	1
9	PCFZZ	5331-00-081-9299	15434	129888	.COIL, ELECTRICAL BIG CAM I.....	1
10	PAFZZ	5310-00-082-1888	15434	129768	.COVER, ACCESS SHUT OFF VALVE.....	1
11	PCFZZ	5331-00-132-0274	15434	190876	.O-RING RECTANGULAR RING PART OF	1
12	PAFZZ	4820-01-146-1048	15434	3030970	KIT P/N 3010242.....	1
13	PAFZZ	3040-01-085-2616	15434	3000266	.WASHER, SPRING TENSIO SHUT OFF VALVE	1
14	PAFZZ	4730-00-011-3175	15434	70295	.O-RING PART OF KIT P/N 3010242....	1
15	PCFZZ	5330-01-291-6537	12361	3903927	.DISK, VALVE.....	1
16	PAFZZ	5355-00-082-1189	15434	129838	.SHAFT, SHOULDERED SHUT OFF VALVE,	1
17	PPFZZ	4820-00-829-5600	15434	129826	BIG CAM III.....	1
					.PLUG, PIPE.....	1
					.PACKING, PREFORMED RECTANGULAR	1
					RING PART OF KIT P/N 3010242.....	1
					.KNOB SHUT OFF VALVE.....	1
					.BODY, VALVE.....	1

END OF FIGURE

1 — 2 thru 29
 48 — 49 thru 52

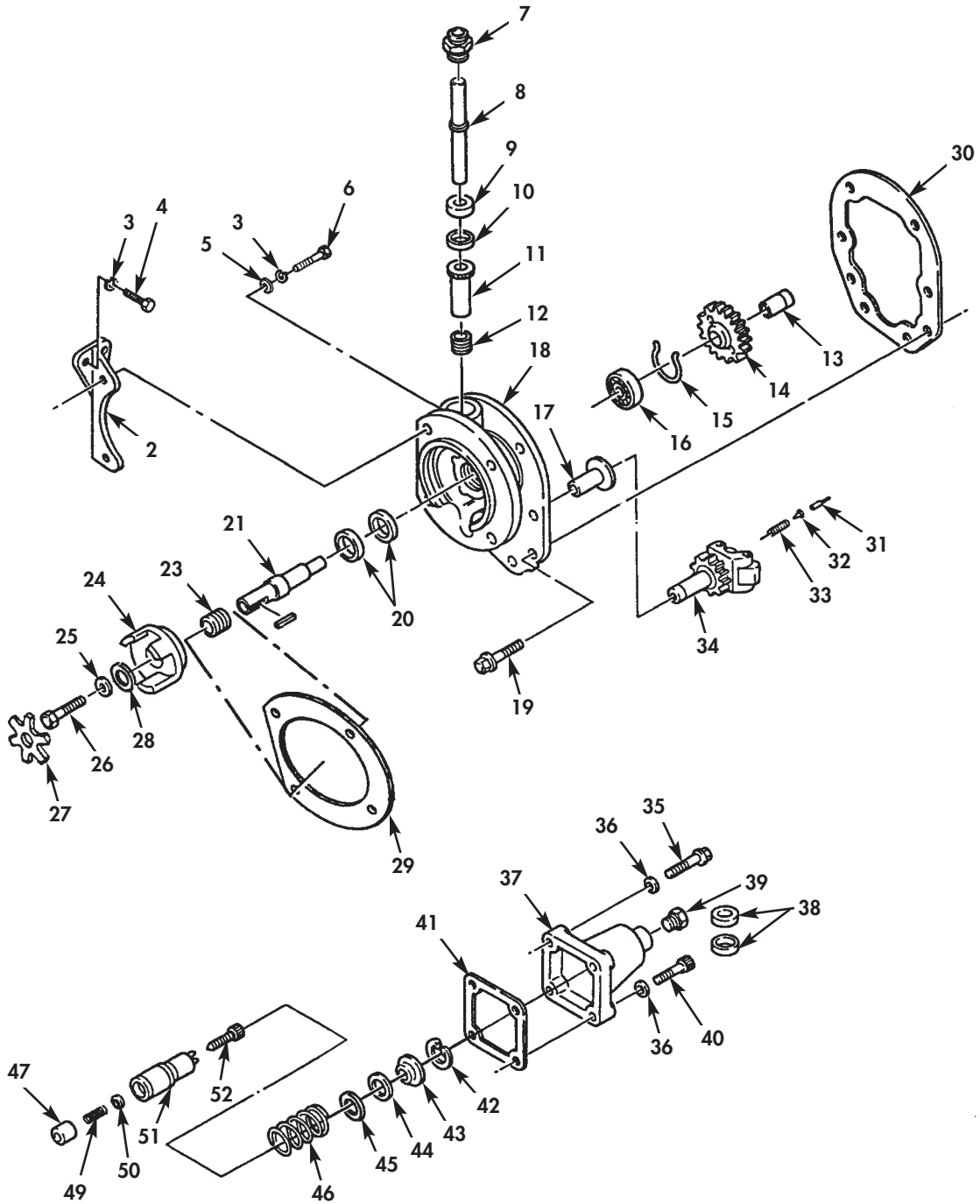


Figure 30. Fuel Pump Front Cover, Governor, and Tach Drive.

(1) ITEM NO	(2) SMR CODE	(3) NSN	(4) CAGEC	(5) PART NUMBER	(6) DESCRIPTION AND USABLE ON CODE(UOC)	(7) QTY
GROUP 0308 ENGINE SPEED GOVERNOR AND CONTROL						
FIG. 30 FUEL PUMP FRONT COVER, GOVERNOR, AND TACH DRIVE						
1	PAFZZ	6680-01-085-2870	15434	3030267	COVER AND TACHOMETE BIG CAM I.....	1
1	PAHHH	2910-01-146-1999	15434	3030269	COVER ASSEMBLY,FRON FUEL PUMP FRONT,BIG CAM III.....	1
2	PFHZZ	5342-01-085-4153	15434	3001296	.BRACKET,AIR COMPRES.....	1
3	PAHZZ	5310-00-209-0965	96906	MS35338-47	.WASHER,LOCK.....	4
4	XBFZZ		15434	S151	.SCREW COVER,GOVERNOR AND TACHOMETER DRIVE.....	4
5	PAHZZ	5310-01-112-4307	15434	69324	.WASHER,FLAT COVER,GOVERNOR AN TACHOMETER DRIVE.....	3
6	PAHZZ	5305-01-113-1179	15434	206326	.SCREW,CAP,HEXAGON H.....	4
7	PAHZZ	2910-01-086-7715	15434	3002110	.HOUSING,DRIVE ASSEM BIG CAM III...	1
8	PAHZZ	3040-01-085-2871	15434	212607	.SHAFT,TACHOMETER DR BIG CAM I.....	1
8	PAHZZ	3040-01-151-9348	15434	21690800	.SHAFT,TACHOMETER DR BIG CAM III...	1
9	PCHZZ	5330-01-072-8828	15434	212603	.SEAL PART OF KIT P/N 3010242.....	1
10	PAHZZ	5365-01-126-3334	15434	3004724	.SPACER BIG CAM III.....	1
11	PAHZZ	3120-01-087-2539	15434	212609	.BEARING,SLEEVE BIG CAM III.....	1
12	PAHZZ	3020-01-086-8780	15434	212610	.GEAR,HELICAL BIG CAM III.....	1
13	PAHZZ	3010-01-088-5727	15434	212639	.COUPLING,SHAFT,RIGI.....	1
14	PAHZZ	3020-01-070-9003	15434	21260500	.GEAR,SPUR.....	1
15	PAHZZ	5325-01-081-0662	15434	212604	.RING,RETAINING.....	1
16	PAHZZ	3110-00-516-5289	15434	S-16052	.BEARING,BALL,ANNULA.....	1
17	PAHZZ	3120-00-904-9595	15434	163944	.BUSHING,SLEEVE.....	1
18	PAFZZ	6680-01-085-2870	15434	3030267	.COVER AND TACHOMETE BIG CAM I.....	1
18	PAHZZ	2910-01-141-4337	15434	3803676	.HOUSING,FUEL PUMP BIG CAM III.....	1
19	PAHZZ	5305-01-072-8831	15434	203619	.SCREW BIG CAM I.....	1
19	PAHZZ	5305-01-112-9110	15434	3017051	.SCREW,CAP,HEXAGON H BIG CAM III...	8
20	XBHZZ		15434	3045173	.SEAL,OIL PART OF KIT P/N 3010242..	2
21	PAHZZ	3040-01-070-9004	15434	212601	.SHAFT,SHOULDERED.....	1
22	PAHZZ	5315-01-087-0534	15434	212668	.KEY,MACHINE.....	1
23	PAHZZ	3020-01-086-4158	15434	212602	.GEAR,HELICAL.....	1
24	PAHZZ	3010-01-080-1529	15434	212613	.COUPLING HALF,SHAFT.....	1
25	PAHZZ	5310-00-809-3078	15434	146160	.WASHER,FLAT BIG CAM III.....	1
25	PAHZZ	5310-00-809-3078	96906	MS27183-11	.WASHER,FLAT BIG CAM I.....	2
26	PAHZZ	5305-01-114-9279	15434	S110	.SCREW,CAP,HEXAGON H 5/16-18 X 5/8 BIG CAM I.....	1
27	PAFZZ	3010-00-447-9799	15434	162426	.INSERT,FLEXIBLE COU.....	1
28	PAHZZ	5310-00-407-9566	96906	MS35338-45	.WASHER,LOCK COVER GOVERNOR AND TACHOMETER DRIVE.....	1
29	PFHZZ	5330-01-338-4829	15434	4026171	.GASKET.....	1
30	PCHZZ	5330-00-506-4866	15434	100764	GASKET PART OF KIT P/N 3010242.....	1
31	PAHZZ	5315-00-082-0448	15434	144178	PIN,SHOULDER,HEADLE BIG CAM III....	1
32	PAHZZ	5310-00-086-7859	15434	144179	SHIM,WEIGHT,ASSIST.....	1
33	PAHZZ	5360-01-095-3661	15434	143848	SPRING,HELICAL,COMP.....	1
34	PAHZZ	2910-01-090-9346	15434	3024991	CARRIER ASSEMBLY.....	1
35	PAHZZ	5305-01-112-9110	15434	3017051	SCREW,CAP,HEXAGON H BIG CAM III....	3
36	PAHZZ	5310-00-141-1795	88044	AN960-416	WASHER,FLAT.....	3
37	PBHZZ	2910-00-858-3522	15434	44678	COVER,SPRING PACK BIG CAM III.....	1
38	PAHZZ	5330-01-072-8830	15434	3003156	SEAL,SPECIAL BIG CAM III.....	1
39	PAHZZ	5342-01-143-6046	15434	3025459	PLUG,COVER BIG CAM III.....	1
40	PAHZZ	5305-00-426-4142	15434	S105	SCREW,CAP,HEXAGON H BIG CAM I.....	1
40	PAHZZ	5305-01-126-1128	15434	3017052	SCREW,CAP,HEXAGON H BIG CAM III....	1
41	PCHZZ	5330-00-562-1176	15434	70705	GASKET BIG CAM III PART OF KIT P/N 3010242.....	1
42	PAHZZ	5325-00-807-2636	96906	MS16625-1100	RING,RETAINING.....	1
43	PAHZZ	5340-00-898-1497	15434	70713	RING RETAINING BIG CAM III.....	1

(1) ITEM NO	(2) SMR CODE	(3) NSN	(4) CAGEC	(5) PART NUMBER	(6) DESCRIPTION AND USABLE ON CODE(UOC)	(7) QTY
44	PAHZZ	5365-00-507-3261	15434	70717-A	SHIM BIG CAM III.....	1
44	PAHZZ	5365-00-507-3262	15434	70717-B	SHIM BIG CAM III	1
44	PAHZZ	5365-00-462-4504	15434	189800	SHIM BIG CAM III.....	1
45	PAHZZ	5365-00-507-3260	15434	70717	SPACER,RING BIG CAM III.....	1
46	PAHZZ	5360-00-461-5738	15434	143251	SPRING,HELICAL,COMP BIG CAM I.....	1
46	PAHZZ	5360-00-901-9644	15434	143253	SPRING,HELICAL,COMP BIG CAM III....	1
47	PAHZZ	5340-00-907-8964	15434	137370	PLUNGER,DETENT IDLE SPRING,BIG CAM III.....	1
48	PAHZZ	2910-00-803-2631	15434	BM70796	SPRING GUIDE,ASSEMB BIG CAM I.....	1
49	PAHZZ	5360-01-147-4846	15434	3018767	.SPRING,HELICAL,COMP BIG CAM III...	1
50	PAHZZ	5310-00-507-3259	15434	70715	.WASHER,FLAT BIG CAM III.....	1
51	PAHZZ	2910-00-132-0769	15434	3038218	.GUIDE,CLIP ASSEMBLY BIG CAM III...	1
52	PAHZZ	5305-00-506-5722	15434	70716	.SETSCREW BIG CAM III.....	1

END OF FIGURE

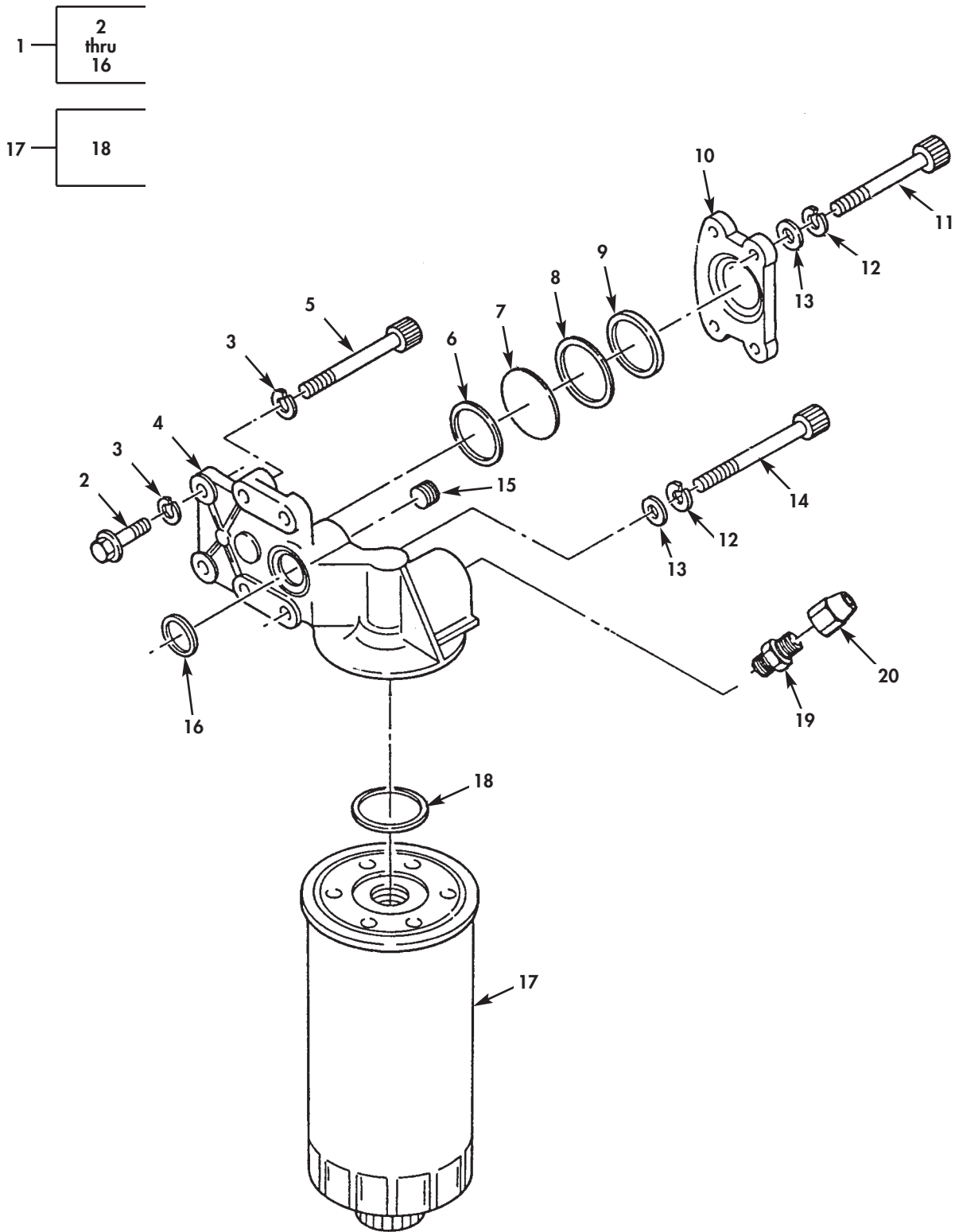
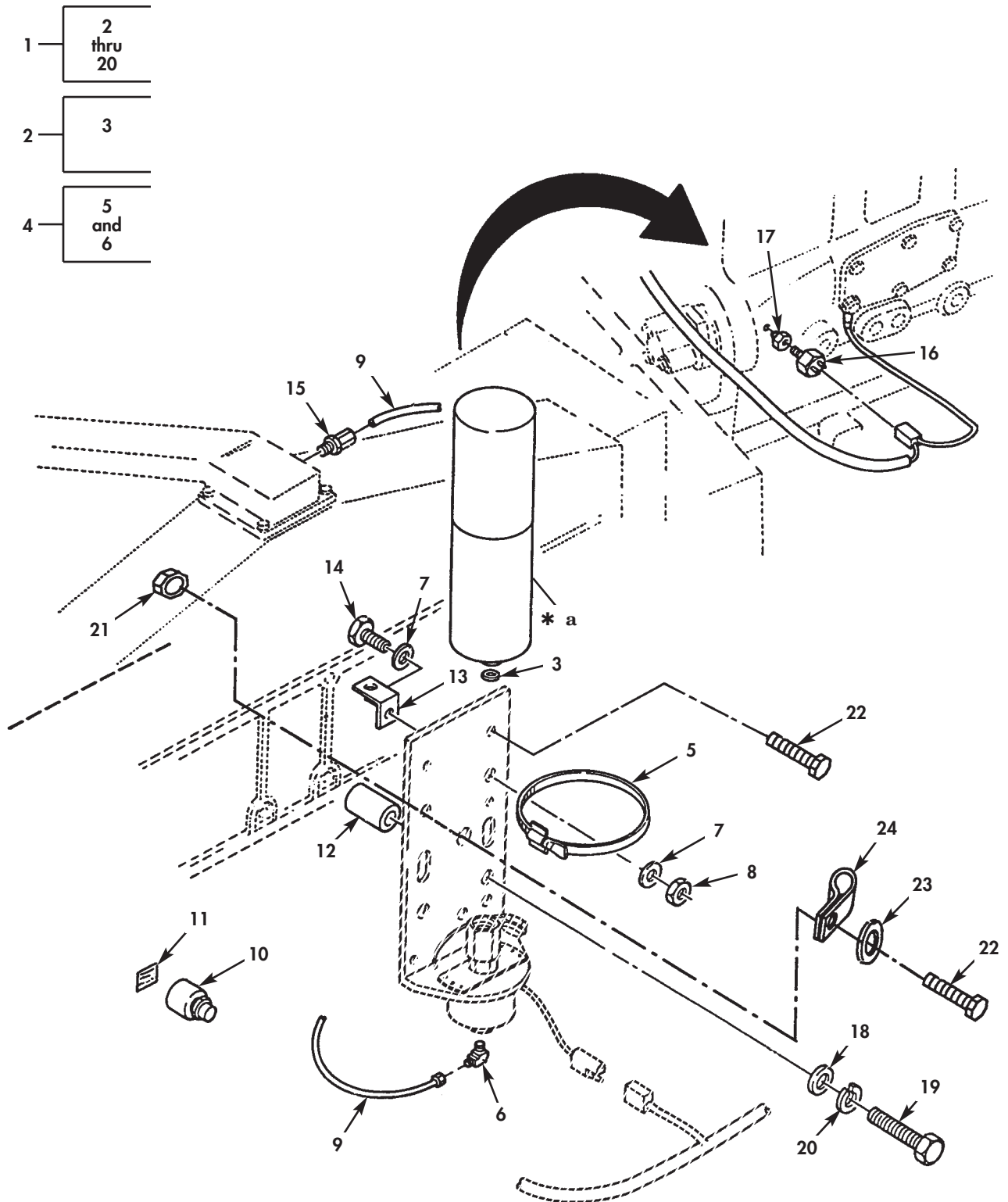


Figure 31. Fuel Pump Damper, Head, and Fuel Filter.

(1) ITEM NO	(2) SMR CODE	(3) NSN	(4) CAGEC	(5) PART NUMBER	(6) DESCRIPTION AND USABLE ON CODE(UOC)	(7) QTY
GROUP 0309 FUEL FILTER						
FIG. 31 FUEL PUMP DAMPER, HEAD, AND FUEL FILTER						
1	PAFFF	2910-01-085-2570	15434	3026198	DAMPER AND HEAD ASS	1
2	PAFZZ	5305-00-068-0509	80204	B1821BH025C125N	.SCREW,CAP,HEXAGON H DAMPER TO GEAR MOTOR,DAMPER,FUEL FILTER,BIG CAM I..	2
2	PAFZZ	5305-01-112-9110	15434	3017051	.SCREW,CAP,HEXAGON H BIG CAM III...	2
3	PAHZZ	5310-00-484-1718	15434	181466	.WASHER,LOCK.....	4
4	XAFZZ		15434	205451	.HEAD, FILTER.....	2
5	PAFZZ	5305-00-207-2715	15434	S-174-C	.SCREW,CAP,SOCKET HE SOCKET HEAD, 1/4-20 X 3 1/2,BIG CAM III.....	2
6	PCFZZ	5331-00-809-3276	15434	139988	.O-RING RECTANGULAR RING PART OF KIT P/N 3010242.....	1
7	PCFZZ	5340-00-951-3536	15434	202897	.DISK,SOLID,PLAIN FUEL PUMP DAMPER..	1
8	PCFZZ	5331-00-809-2667	15434	100099	.O-RING RECTANGULAR RING PART OF KIT P/N 3010242.....	1
9	PAFZZ	5365-00-965-0870	15434	160514	.SPACER,RING.....	1
10	PAFZZ	5340-00-829-5617	15434	153338	.COVER,ACCESS.....	1
11	PAFZZ	5305-01-133-2060	15434	133538	.SCREW,CAP,SOCKET HE SOCKET HEAD, 1/4-20 X 3 1/4.....	1
12	PAFZZ	5310-00-159-6209	96906	MS122032	.WASHER,LOCK.....	2
13	PAFZZ	5310-00-141-1795	88044	AN960-416	.WASHER,FLAT.....	2
14	PAFZZ	5305-01-147-8726	15434	153346	.SCREW,CAP,SOCKET HE SOCKET HEAD, 1/4-20 X 4.00.....	1
15	PAFZZ	4730-01-124-3762	15434	3025460	.PLUG,PIPE.....	5
16	PAFZZ	5330-00-252-8888	9F512	691-10014	.GASKET RECTANGULAR RING PART OF KIT P/N 3010242.....	1
17	PAOZZ	2910-00-304-3427	15434	BM78793	FILTER ELEMENT,FLUI BIG CAM I.....	1
17	PAOZZ	2910-01-146-1099	79396	33405	FILTER ELEMENT,FLUI BIG CAM III.....	1
18	PAOZZ	5330-01-084-9068	15434	213079	.PACKING,PREFORMED DAMPER,FUEL FILTER, BIG CAM I.....	1
18	PCOZZ	5330-00-286-0487	33457	255622	.PACKING,PREFORMED BIG CAM III.....	1
19	PAFZZ	4730-01-106-4700	15434	129866	ADAPTER,STRAIGHT,TU DAMPER,FUEL FILTER.....	1
20	PAFZZ		15434	AR12228	FITTING FUEL INLET.....	1

END OF FIGURE



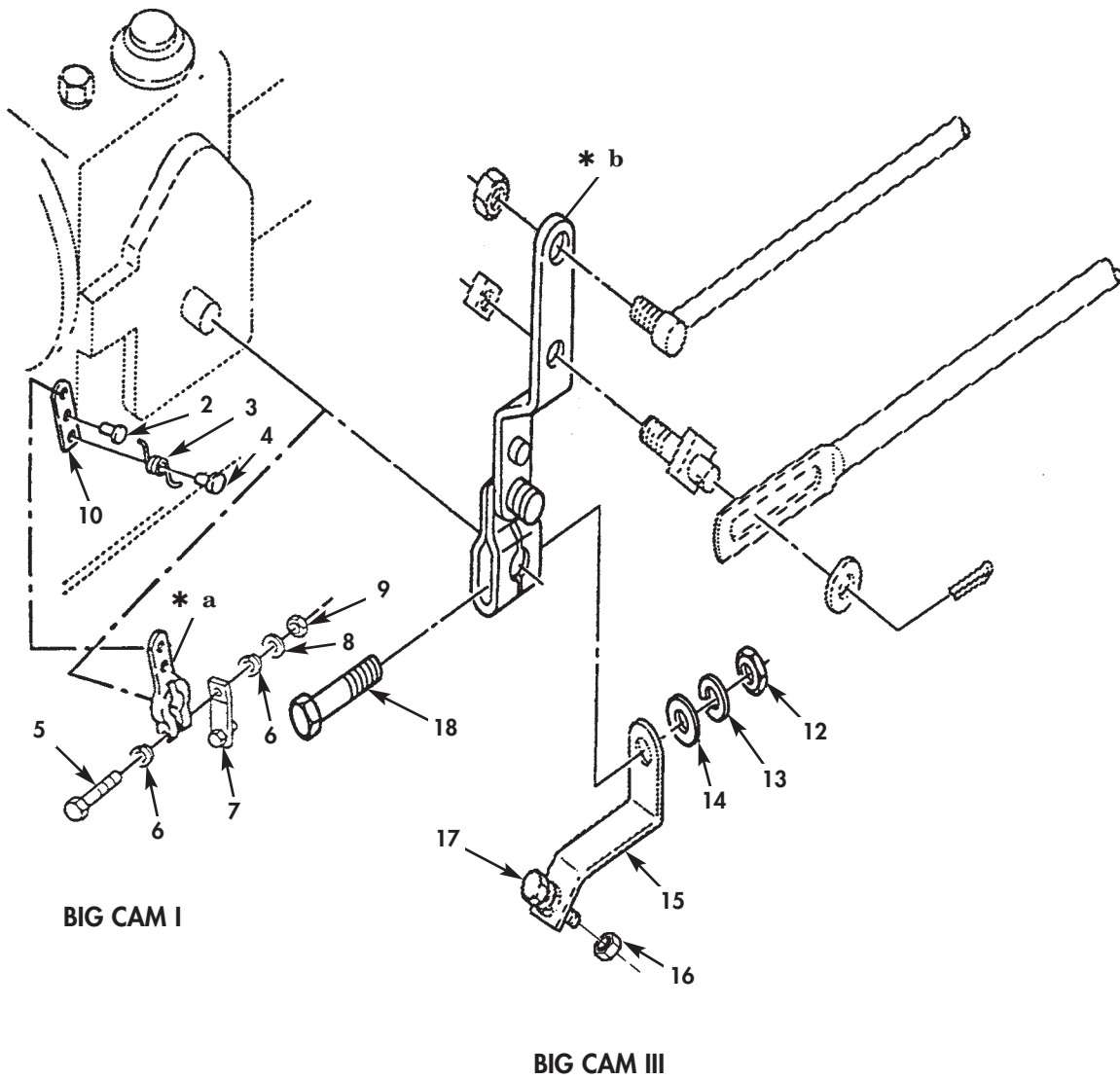
* a PART OF ITEM 2

Figure 32. Ether Quick-Start Kit.

(1) ITEM NO	(2) SMR CODE	(3) NSN	(4) CAGEC	(5) PART NUMBER	(6) DESCRIPTION AND USABLE ON CODE(UOC)	(7) QTY
GROUP 0311 WHEEL ASSEMBLY						
FIG. 32 ETHER QUICK-START KIT						
1	PFOOO	2815-01-087-4740	06991	8294151	QUICK START KIT ETHER.....	1
2	PAOZZ	2910-00-646-9727	53203	20000	.CYLINDER,ENGINE STA.....	1
3	PCOZZ	5330-01-147-8754	06991	111025	..GASKET.....	1
4	PAOZZ	2910-01-084-0243	6Y402	829-4151	.PARTS KIT,ETHER,STA ASSEMBLY.....	1
5	PAOZZ	5340-01-145-1181	06991	913020	..CLAMP,LOOP BIG CAM III.....	1
6	PAOZZ	4730-01-146-1059	06991	125049	..ELBOW,PIPE TO TUBE.....	1
7	PAOZZ	5310-01-146-6150	06991	103031	.WASHER,FLAT.....	2
8	PAOZZ	5310-01-146-6147	06991	102030	.NUT,PLAIN,HEXAGON 5/16-18.....	1
9	PCOZZ	4720-01-146-4126	06991	501096-04	.TUBING,NONMETALLIC 24 INCHES.....	1
10	XBOZZ	5930-01-295-0912	6Y402	8293635	.SWITCH,THERMOSTATIC BIG CAM I.....	1
10	PAOZZ	5930-01-095-9823	06991	309015	.SWITCH,PUSH ETHER START, SEE TM9- 2320-283-20P, BIG CAM III.....	1
11	PCOZZ	7690-01-080-7335	34623	M-A162-20018	.MARKER,IDENTIFICATI SEE TM9-2320- 283-20P.....	1
12	PAOZZ		06991	501088-02	.SPACER,SLEEVE.....	2
13	PAOZZ	5342-01-146-9816	06991	108289	.CLAMP.....	1
14	PAOZZ	5306-01-151-1023	06991	101037-05	.BOLT,MACHINE 5/16-18 X 1.00.....	1
15	PAOZZ	2910-01-112-5797	06991	913024-06	.ATOMIZER,QUICK STAR.....	1
16	PAOZZ	6620-01-203-4301	06991	321030-02	.THERMOSTAT,FLOW CON.....	1
17	PAOZZ	4730-00-278-4822	72582	444042	.ELBOW,PIPE BIG CAM III.....	1
18	PAOZZ	5310-01-146-7303	34623	MB362-20001	.WASHER,FLAT.....	2
19	PAOZZ	5306-00-418-2276	24617	272547	.BOLT,MACHINE 3/8-16 X 6 1/2.....	2
20	PAOZZ	5310-00-637-9541	96906	MS35338-46	.WASHER,LOCK.....	2
21	PAOZZ	5310-00-013-1245	21450	131245	NUT,SELF-LOCKING,HE.....	1
22	PAOZZ		24617	9419002	SCREW,CAP,HEXAGON H.....	2
23	PAOZZ	5310-01-102-3270	24617	2436161	WASHER,FLAT.....	1
24	PAOZZ	5340-00-809-1490	96906	MS21333-98	CLAMP,LOOP.....	1

END OF FIGURE

- 1 — 2 thru 10
- 11 — 12 thru 18



- * a PART OF ITEM 1
- * b PART OF ITEM 11

Figure 33. Fuel Control Lever.

(1) ITEM NO	(2) SMR CODE	(3) NSN	(4) CAGEC	(5) PART NUMBER	(6) DESCRIPTION AND USABLE ON CODE(UOC)	(7) QTY
GROUP 0312 ACCELERATOR, THROTTLE OR CHOKE CONTROLS						
FIG. 33 FUEL CONTROL LEVER						
1	AOOOO		15434	AR51323	LEVER ASSEMBLY,THRO.....	1
2	PAOZZ	2910-00-410-2268	34623	MA207-21-642	.STOP,THROTTLE LEVER.....	1
3	PAOZZ	5360-00-436-7340	15434	173717	.SPRING,HELICAL,TORS.....	1
4	PAHZZ	2910-00-432-1945	15434	3048296	.LEVER,REMOTE CONTRO BIG CAM I.....	1
5	PAOZZ	5305-00-493-3959	15434	S-159-B	.SCREW,CAP,HEXAGON H 1/4-28 X 1 1/2	1
6	PAOZZ	3120-00-353-9164	15434	S2876	.BUSHING,SLEEVE BIG CAM I.....	2
7	PAOZZ	3040-01-154-9787	34623	5995177	.LEVER,REMOTE CONTRO.....	1
8	PAOZZ	5310-00-562-6552	15434	S600	.WASHER,LOCK.....	1
9	PAOZZ	5310-00-971-7989	96906	MS35691-5	.NUT,PLAIN,HEXAGON.....	1
10	XDHZZ		15434	173708	.CONNECTING LINK,RIG.....	1
11	PAOZZ	2910-01-146-2000	15434	3061420	LEVER ASSEMBLY,THRO FUEL CONTROL...	1
12	PAOZZ	5310-00-971-7989	96906	MS35691-5	.NUT,PLAIN,HEXAGON.....	1
13	PAHZZ	5310-00-159-6209	96906	MS122032	.WASHER,LOCK.....	1
14	PAOZZ	5310-00-141-1795	58588	AN960-416	.WASHER,FLAT.....	1
15	PBHZZ	5340-01-208-9319	34623	MB70-20107	.BRACKET,ACCELERATOR.....	1
16	PAOZZ	5310-01-102-7356	24617	9421077	.NUT,PLAIN,HEXAGON.....	1
17	PAOZZ	5305-01-088-6019	15434	3010596	.SCREW,ASSEMBLED WAS.....	1
18	PAOZZ	5306-01-102-3599	24617	9421196	.BOLT,MACHINE.....	1

END OF FIGURE

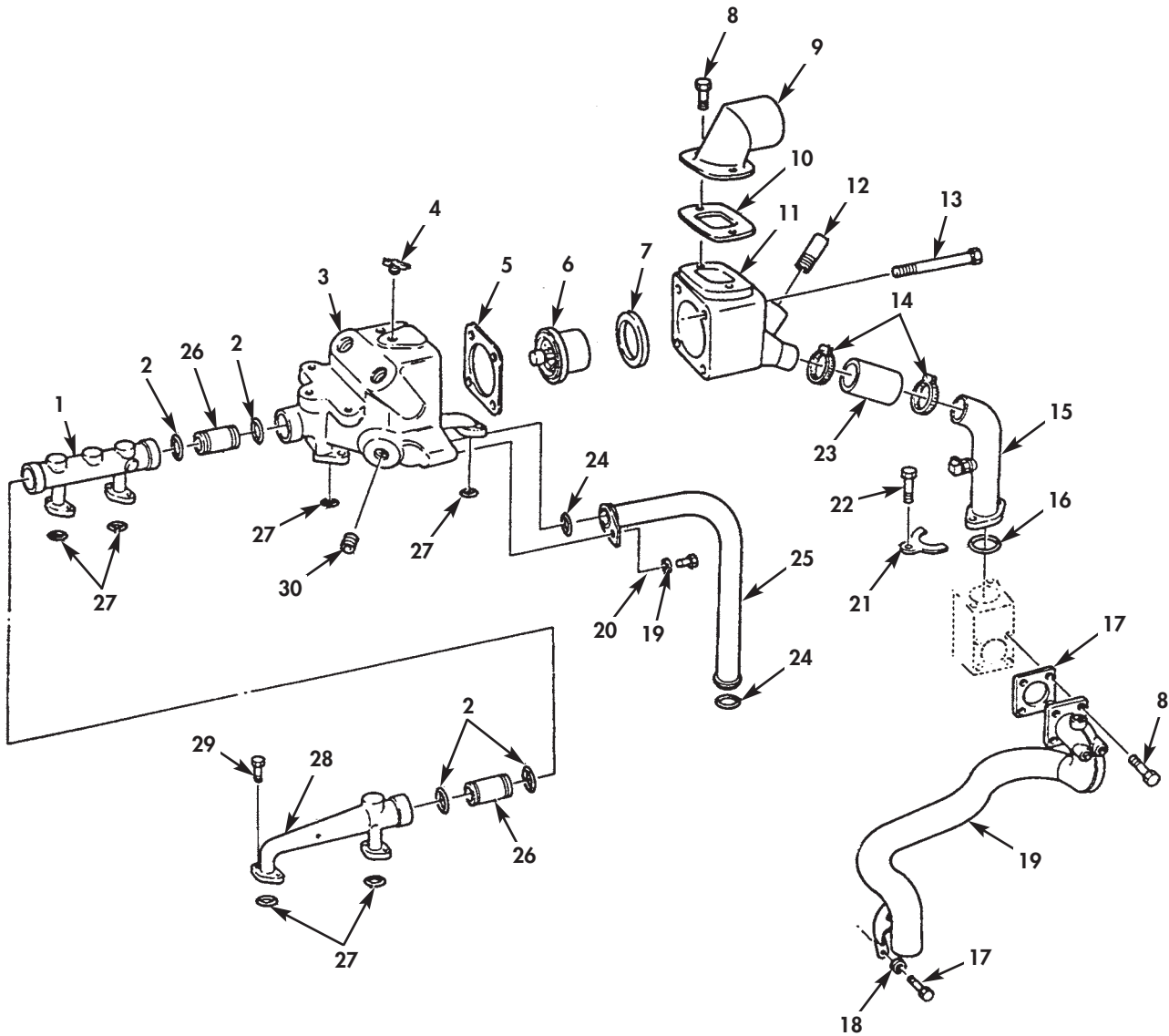


Figure 34. Thermostat Housing, Water Manifold, and Component Parts.

(1) ITEM NO	(2) SMR CODE	(3) NSN	(4) CAGEC	(5) PART NUMBER	(6) DESCRIPTION AND USABLE ON CODE(UOC)	(7) QTY
GROUP 05 COOLING						
GROUP 0503 WATER MANIFOLD, HEADERS						
THERMOSTATS, AND HOUSING GASKET						
FIG. 34 THERMOSTAT HOUSING, WATER						
MANIFOLD, AND COMPONENT PARTS						
1	PAOZZ	2930-00-928-3595	15434	130118	MANIFOLD,FLUID COOL WATER.....	1
2	PCOZZ	5331-00-506-4874	15434	70624	O-RING PART OF KIT P/N 4024958 PART OF KIT P/N 3804280.....	4
3	PAOZZ	2815-01-083-2123	15434	215042	MANIFOLD,WATER BIG CAM I.....	1
3	PAOZZ	2930-01-146-4212	15434	3015114	MANIFOLD,FLUID COOL BIG CAM III....	1
4	PAOZZ	4820-01-210-9571	15434	214345	COCK,DRAIN.....	1
5	PFOZZ	5330-01-040-2087	15434	208128	GASKET PART OF KIT P/N 4024958 PART OF KIT P/N 3804280.....	1
6	PAOZZ	6685-01-141-0907	15434	201737	THERMOSTAT,FLOW CON BIG CAM III....	1
6	PAOZZ	6685-01-047-2811	15434	204586	THERMOSTAT,FLOW CON BIG CAM I.....	1
7	PFOZZ	5330-00-864-5422	15434	186780	SEAL,THERMO PART OF KIT P/N 3804280	1
8	PAOZZ	5305-01-085-8197	15434	3010595	SCREW,MACHINE.....	6
9	PAOZZ		15434	210916	ELBOW,FLANGE TO HOS BIG CAM I.....	1
9	PAOZZ	2930-01-146-1085	15434	3018764	WATER OUTLET,ENGINE WATER OUTLET, BIG CAM III.....	1
10	PCOZZ	5330-01-145-5380	15434	3019158	GASKET.....	1
11	PAOZZ	2930-01-084-6011	15434	211435	WATER OUTLET,ENGINE BIG CAM I.....	1
11	PFOZZ	2930-01-150-7596	15434	3017748	WATER OUTLET,ENGINE BIG CAM III....	1
12	PAOZZ	4730-01-085-4156	15434	196282	ELBOW,FLANGE TO HOS BIG CAM I.....	1
12	PAOZZ	4730-01-146-1060	15434	S-932-B	ADAPTER,STRAIGHT,PI BIG CAM III....	1
13	PAOZZ	5305-01-086-7036	15434	3010597	SCREW WITH CAPTIVE WASHER, 3/8-16 X 3 3/4.....	4
14	PAOZZ	4730-00-909-8627	34623	5583303	CLAMP,HOSE.....	2
15	PAOZZ	4710-01-079-3198	15434	213485	TUBE,BENT,METALLIC BIG CAM I.....	1
15	PAOZZ	4710-01-146-1054	15434	3018098	TUBE,BENT,METALLIC BIG CAM III....	1
16	PAOZZ	5331-00-159-1464	15434	3000521	O-RING BIG CAM III PART OF KIT P/N 3801235.....	1
17	PCOZZ	5330-01-146-7314	15434	3024960	GASKET PART OF KIT P/N 3801235....	1
18	PAOZZ	2930-01-146-3033	15434	3028281	HOUSING,WATER INLET BIG CAM III....	1
19	PAOZZ	5305-01-113-0408	15434	3012470	SCREW,ASSEMBLED WAS WITH CAPTIVE WASHER, 3/8-16 X 3/4,BIG CAM III....	2
20	PAFZZ	5310-00-081-4219	96906	MS27183-12	WASHER,FLAT BIG CAM III.....	2
21	PAOZZ	5340-01-135-7250	15434	214617	CLAMP,RIM CLENCHING.....	1
22	PAOZZ	5306-01-119-8870	15434	3022589	BOLT,MACHINE HEXAGON HEAD, WITH CAPTIVE WASHER,BIG CAM III.....	1
23	PCOZZ	4720-01-085-6129	15434	102522	HOSE,NONMETALLIC.....	1
24	PCOZZ	5331-01-077-5228	15434	212161	O-RING PART OF KIT P/N 3804280....	2
25	PAOZZ	4710-01-146-3086	15434	3024666	TUBE,BENT,METALLIC BIG CAM III....	1
26	PAOZZ	4730-00-404-2906	15434	130394	COUPLING,TUBE.....	2
27	PCOZZ	5330-01-145-5381	15434	3024709	GASKET BIG CAM III PART OF KIT P/N 4024958 PART OF KIT P/N 3801235.	6
28	PAOZZ	2930-01-087-8749	15434	3013000	MANIFOLD,FLUID COOL.....	1
29	PAOZZ	5305-01-088-6019	15434	3010596	SCREW,ASSEMBLED WAS 3/8-16 X 1 1/4.	12
30	PAOZZ	4730-00-221-2139	72452	1459-259	PLUG,PIPE.....	1

END OF FIGURE

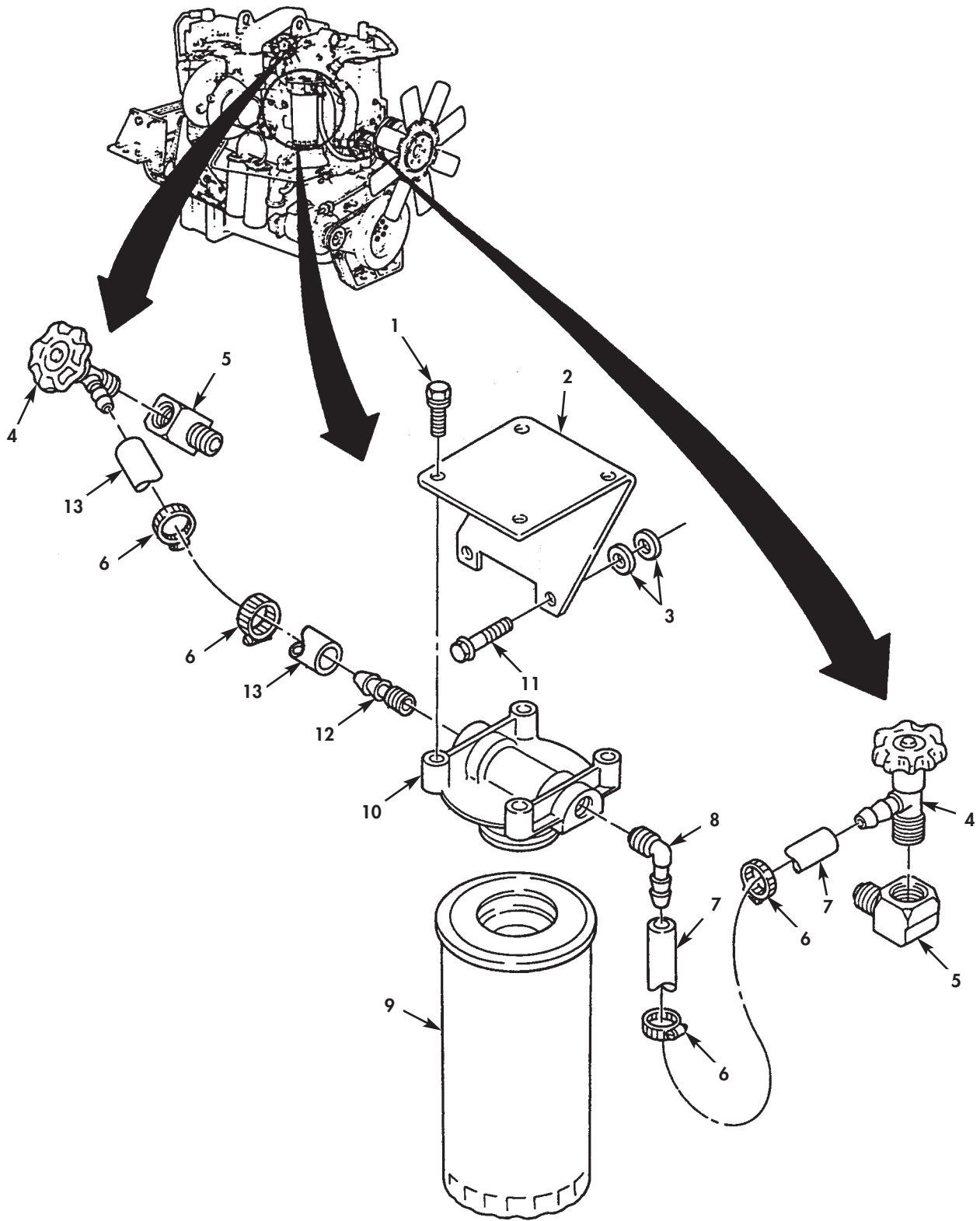
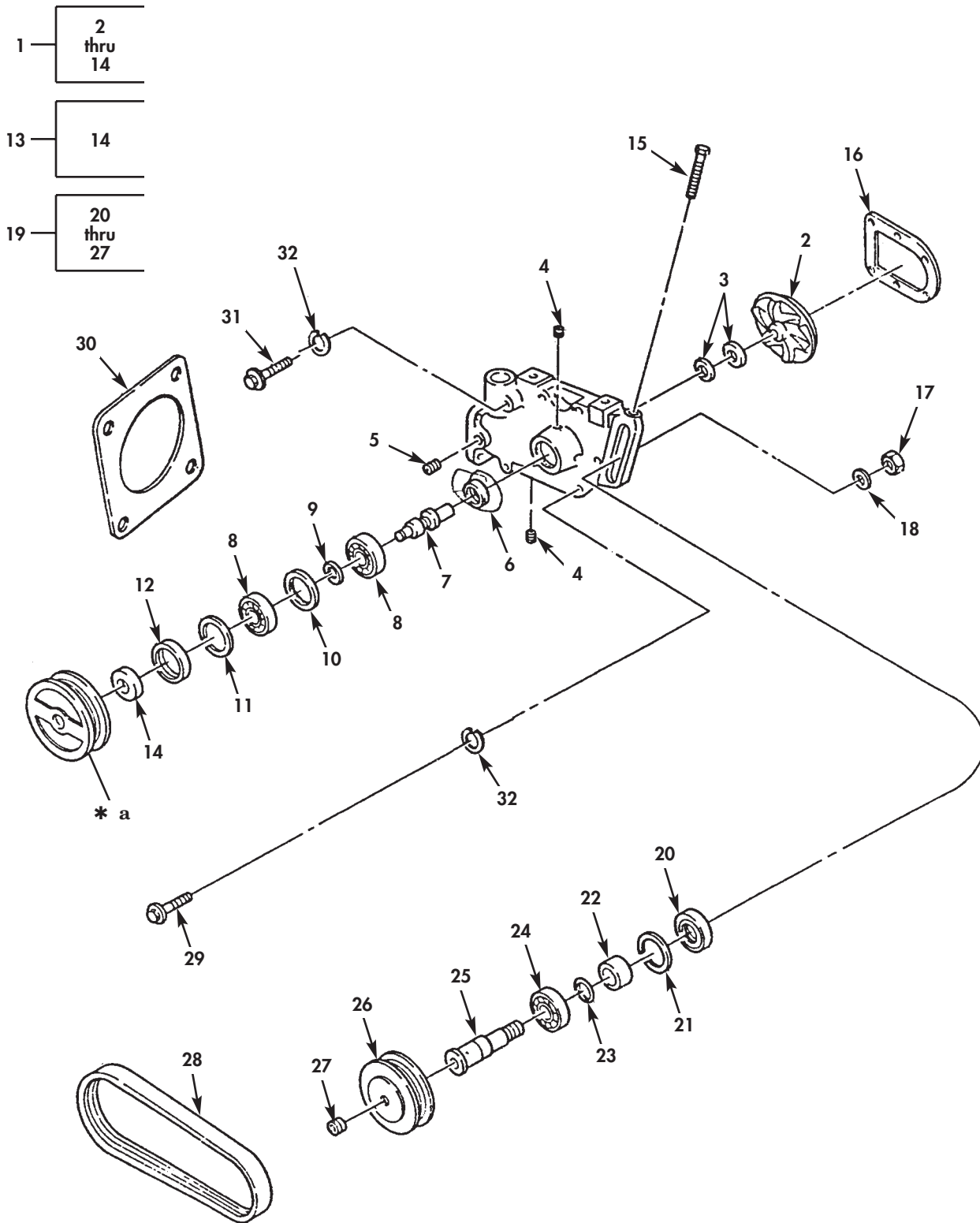


Figure 35. Water Filter and Component Parts.

(1) ITEM NO	(2) SMR CODE	(3) NSN	(4) CAGEC	(5) PART NUMBER	(6) DESCRIPTION AND USABLE ON CODE(UOC)	(7) QTY
GROUP 0503 WATER MANIFOLD, HEADERS THERMOSTATS AND HOUSING GASKET						
FIG. 35 WATER FILTER AND COMPONENT PARTS						
1	PAOZZ	5305-01-088-6019	15434	3010596	SCREW,ASSEMBLED WAS 3/8-16 X 1 1/4.	4
2	PAOZZ	5340-01-145-1597	15434	211448	BRACKET,ANGLE FILTER MOUNTING PART OF KIT P/N 5739124.....	1
3	PAOZZ	3120-01-079-6527	15434	109594	BEARING,SLEEVE.....	4
4	PAOZZ	4820-01-227-7141	34623	5730765	VALVE,ANGLE BIG CAM I.....	2
4	PAOZZ	4820-01-045-6080	15434	179901	VALVE,ANGLE WATER SHUT-OFF, BIG CAM III.....	2
5	PAOZZ	4730-01-165-0749	15434	70470	ELBOW,TUBE.....	2
6	PAOZZ	4730-00-908-3195	81343	SAEJ1508-06	CLAMP,HOSE BIG CAM I.....	4
6	PAOZZ	4730-01-146-4016	15434	179904	CLAMP,HOSE BIG CAM III.....	4
7	MOOZZ		34623	5710454	HOSE BIG CAM I,MAKE FROM HOSE, P/N 2580-6.....	1
7	MOOZZ	4720-00-160-9649	15434	179912	HOSE,NONMETALLIC BIG CAM III,MAKE FROM HOSE, P/N 2580-6.....	1
8	PAOZZ	4730-01-045-3083	15434	179903	ELBOW,PIPE TO HOSE BIG CAM III.....	1
9	PAOZZ	4330-00-274-4712	33457	3305367	FILTER ELEMENT,FLUI PART OF KIT P/N 5739124.....	1
10	PFOZZ	2940-01-227-7445	34623	5730769	HEAD,FLUID FILTER BIG CAM I.....	1
10	PAOZZ	4330-01-020-3666	33457	204163	HEAD,FLUID FILTER BIG CAM III.....	1
11	PAOZZ	5305-01-319-9287	15434	3043649	SCREW,CAP,HEXAGON H.....	2
12	PAOZZ	4730-01-216-6440	15434	179902	COUPLING HALF,QUICK BIG CAM III.....	1
13	MOOZZ	4720-00-187-4102	01276	2580-6	HOSE,NONMETALLIC MAKE FROM HOSE, P/N 2580-6.....	1

END OF FIGURE



* a PART OF ITEM 13

Figure 36. Water Pump and Idler.

(1) ITEM NO	(2) SMR CODE	(3) NSN	(4) CAGEC	(5) PART NUMBER	(6) DESCRIPTION AND USABLE ON CODE(UOC)	(7) QTY
GROUP 0504 WATER PUMP						
FIG. 36 WATER PUMP AND IDLER PULLEY						
1	PAOFF	2930-01-146-3912	15434	3801708	PUMP,COOLING SYSTEM BIG CAM I AND BIG CAM III.....	1
2	PAFZZ	4320-01-079-3454	15434	3000888	.IMPELLER,PUMP,CENTR 4.50" DIA. BIG CAM I AND BIG CAM III PART OF KIT P/N 380171200.....	1
3	PCFZZ	5330-00-005-0407	15434	3071085	.PACKING WITH RETAIN PART OF KIT P/N 380171200 PART OF KIT P/N 380171000.....	2
4	PAFZZ	4730-00-018-9566	15434	S-911-B	.PLUG,PIPE.....	2
5	PAFZZ	4730-00-010-3867	81348	WW-P-471AASBUC	.PLUG,PIPE BIG CAM I.....	2
5	PAFZZ	4730-01-161-5115	15434	3013786	.PLUG,PIPE BIG CAM III.....	1
6	PAFZZ	5330-01-240-1630	15434	3038997	.SEAL,PLAIN.....	1
7	PAFZZ	3040-01-287-9736	15434	3050394	.SHAFT,SHOULDERED PART OF KIT P/N 380171200.....	1
8	PAFZZ	3110-00-144-8828	24617	3305L1A	.BEARING,BALL,ANNULA PART OF KIT P/N 380171000.....	2
9	PAFZZ	5325-00-420-9696	15434	112302	.RING,RETAINING.....	1
10	PAFZZ	5365-01-132-1984	15434	196844	.SPACER PART OF KIT P/N 380171200..	1
11	PAFZZ	2815-00-815-0355	15434	S16255	.RING,BEARING RETAIN PART OF KIT P/N 380171000.....	1
12	PCFZZ	5330-01-080-2992	15434	3038998	.SEAL,PLAIN ENCASED PART OF KIT P/N 3801235.....	1
13	PAFZZ	3020-01-241-6905	15434	302586100	.PULLEY,GROOVE 4-5/16 DIA.BIG CAM I	1
13	PAFZZ	3020-01-086-3417	15434	300550700	.PULLEY,GROOVE 4-11/16 DIA.BIG CAM I AND BIG CAM III.....	1
14	PAFZZ	3120-01-083-6411	15434	203097	.BEARING,SLEEVE.....	1
15	PAOZZ	5305-00-058-6604	15434	182706	SCREW,CAP,HEXAGON H.....	1
16	PFOZZ	5330-01-066-5350	15434	3002385	GASKET PART OF KIT P/N 3801235.....	1
17	PAOZZ	5310-00-763-8920	96906	MS51967-20	NUT,PLAIN,HEXAGON.....	1
18	PAOZZ	5310-01-145-0762	15434	213082	WASHER,FLAT.....	1
19	PAOZZ	2930-01-262-5175	15434	3064919	ADJUSTING DEVICE,BE.....	1
20	PAFZZ	5330-01-080-2992	15434	3038998	.SEAL,PLAIN ENCASED.....	1
21	PAFZZ	2815-00-815-0355	15434	S-16255	.RING,BEARING RETAIN.....	1
22	PAFZZ	5365-01-080-0409	15434	208120	.SPACER,SLEEVE.....	1
23	PCFZZ	5331-01-086-3991	15434	145506	.O-RING.....	1
24	PAFZZ	3110-00-144-8828	24617	3305L1A	.BEARING,BALL,ANNULA.....	1
25	PAFZZ	3040-01-079-3468	15434	208119	.SHAFT,SHOULDERED.....	1
26	PAFZZ	3020-01-079-4206	15434	21539700	.PULLEY,GROOVE.....	1
27	PAFZZ	5365-00-404-2934	15434	S-965-E	.PLUG,MACHINE THREAD.....	1
28	PAOZZ	3030-01-065-9404	24161	K060436	BELT,V 45.50 INCHES LONG.....	1
29	PAOZZ	5305-01-129-4386	15434	3012468	SCREW,CAP,HEXAGON H WITH CAPTIVE WASHER, 3/8-24 X 2-1/4.....	5
30	PCOZZ	5330-01-146-7314	15434	3024960	GASKET PART OF KIT P/N 380171200 PART OF KIT P/N 3801235 PART OF KIT P/N 380171000.....	1
31	PAOZZ	5305-01-147-4035	15434	3012469	SCREW,CAP,HEXAGON H WITH CAPTIVE WASHER, 3/8-24 X 3-1/4.....	2
32	PAOZZ	5310-00-261-7340	15434	S604	WASHER,LOCK.....	7

END OF FIGURE

(1) ITEM NO	(2) SMR CODE	(3) NSN	(4) CAGEC	(5) PART NUMBER	(6) DESCRIPTION AND USABLE ON CODE(UOC)	(7) QTY
					GROUP 94 REPAIR KITS GROUP 9401 REPAIR KITS	
					FIG. KITS	
1	PAFZZ	5365-00-716-5496	15434	AR01176	SHIM SET SHIM (2) 16 - 4 SHIM (V) 16 - 4 SHIM (V) 16 - 4 SHIM (V) 16 - 4	1
2	PAFZZ	2815-00-913-2074	15434	AR-73350	RING SET,PISTON RING, COMPRESSION, (1) 20 - 18 RING,PISTON (1) 20 - 17 RING,PISTON (1) 20 - 19	1
3	PAHZZ	5330-01-075-0948	15434	3010242	GASKET SET FUEL PUMP GASKET GASKET (1) 24 - 32 GASKET (1) 31 - 16 GASKET (1) 25 - 2 GASKET (1) 30 - 31 GASKET (1) 30 - 42 GASKET (1) 24 - 8 GASKET (1) 25 - 13 O-RING (1) 29 - 11 O-RING (2) 24 - 14 O-RING (1) 29 - 9 O-RING (1) 24 - 52 O-RING (1) 31 - 6 O-RING (1) 31 - 8 PACKING,PREFORMED (1) 29 - 15 PACKING,PREFORMED (2) 13 - 12 PACKING,PREFORMED (1) 24 - 19 PACKING,PREFORMED (1) 24 - 20 SEAL (1) 30 - 10 SEAL,OIL (2) 30 - 21 SEAL,SPECIAL (1) 24 - 11	1
4	PAHZZ	5330-01-092-4143	15434	3018762	GASKET SET BIG CAM I GASKET (1) 11 - 39 GASKET (2) 11 - 3 GASKET (1) 11 - 48 GASKET (1) 11 - 26 GASKET (1) 11 - 16 GASKET (1) 13 - 2 GASKET (3) 7 - 8 PACKING,PREFORMED (2) 11 - 49 PACKING,PREFORMED (2) 11 - 29 SPACER,RING (1) 11 - 24	1
5	PAHZZ	4820-01-158-0555	15434	302112400	VALVE,CHECK ADAPTER,STRAIGHT,PI (2) 22 - 31 BODY,CHECK VALVE (1) 22 - 24 CLAMP (1) 22 - 28 CLAMP,HOSE (4) 22 - 23 SCREW,CAP,HEXAGON (1) 22 - 27 SCREW,CAP,HEXAGON (1) 22 - 29 TANK,AIR (1) 22 - 30 WASHER,LOCK (1) 22 - 25 WASHER,LOCK (2) 13 - 32 WASHER,PLAIN (1) 22 - 26	1
6	PAHZZ	2815-01-165-0765	15434	3801056	RING SET,PISTON RING,PISTON (6) 6 - 4 RING,PISTON (6) 6 - 2	6

(1) ITEM NO	(2) SMR CODE	(3) NSN	(4) CAGEC	(5) PART NUMBER	(6) DESCRIPTION AND USABLE ON CODE(UOC)	(7) QTY
7	PAHZZ	2990-01-271-0316	15434	3801096	RING,PISTON (6) 6 - 1 RING,PISTON (6) 6 - 3 PARTS KIT,SUPERCHAR BIG CAM III ... GASKET (1) 27 - 12 NUT,SELF-LOCKING (1) 27 - 5 PACKING,PREFORMED (1) 27 - 11 PACKING,FLAT FIBER (1) 27 - 15 PLATE,DIFFUSER (1) 27 - 10 SCREW,CAP HEXAGON H (1) 27 - 9 SEAL,TURBO (1) 27 - 2 SEAL,PLAIN (2) 27 - 17 WASHER,FLAT (4) 27 - 6	
8	PAHZZ	2815-01-168-3742	15434	3801058	PISTON,INTERNAL COM PIN,PISTON (6) 6 - 7 PISTON (6) 6 - 5 RING,RETAINING (12) 6 - 6	6
9	PFHZZ	3120-01-155-2531	15434	3801106	BEARING SET,SLEEVE CAMSHAFT BEARING,SLEEVE (1) 2 - 30 BUSHING,SLEEVE (4) 2 - 30 BUSHING,SLEEVE (2) 2 - 30	1
10	PAHZZ	5330-01-150-9812	15434	3801235	GASKET AND SEAL SET COMPLETE OVERHAUL GASKET (1) 2 - 13 GASKET (1) 4 - 1 GASKET (3) 7 - 8 GASKET (3) 7 - 8 GASKET (3) 7 - 8 GASKET (3) 7 - 8 GASKET (1) 10 - 22 GASKET (1) 10 - 10 GASKET (1) 10 - 9 GASKET (1) 10 - 30 GASKET (1) 12 - 1 GASKET (1) 12 - 30 GASKET (1) 13 - 2 GASKET (1) 13 - 49 GASKET (1) 13 - 34 GASKET (1) 13 - 34 GASKET (1) 16 - 11 GASKET (1) 17 - 19 GASKET (1) 34 - 17 GASKET (1) 34 - 27 GASKET (1) 36 - 30 O-RING (1) 2 - 39 O-RING (1) 10 - 5 O-RING (1) 10 - 23 O-RING (1) 10 - 18 O-RING (1) 13 - 47 O-RING (1) 16 - 5 PACKING,PREFORMED (1) 34 - 16 SEAL (1) 4 - 4 SEAL (1) 4 - 10 SEAL,PLAIN ENCASED (1) 16 - 6 SEAL,PLAIN ENCASED (1) 36 - 12	1
11	PAFZZ	2815-01-152-9219	15434	4024958	PARTS KIT,CYLINDER SINGLE HEAD GASKET GASKET (3) 21 - 11 GASKET (1) 14 - 3 GASKET (3) 3 - 23	1

(1) ITEM NO	(2) SMR CODE	(3) NSN	(4) CAGEC	(5) PART NUMBER	(6) DESCRIPTION AND USABLE ON CODE(UOC)	(7) QTY
					GASKET (6) 15 - 4	
					GASKET (1) 26 - 8	
					GASKET (1) 14 - 8	
					GASKET (3) 14 - 33	
					GASKET (1) 34 - 5	
					GASKET (1) 26 - 1	
					GASKET (6) 34 - 27	
					GASKET (3) 8 - 3	
					O-RING (12) 3 - 22	
					O-RING (4) 34 - 2	
					PACKING, PREFORMED (4) 14 - 7	
12	PAFZZ	5330-01-086-7790	15434	3804280	GASKET SET UPPER ENGINE GASKET, VALVE GRIND	1
					GASKET (12) 3 - 22	
					GASKET (3) 3 - 23	
					GASKET (3) 21 - 11	
					GASKET (3) 8 - 32	
					GASKET (6) 15 - 4	
					GASKET (1) 26 - 8	
					GASKET (1) 26 - 1	
					GASKET (3) 14 - 33	
					GASKET (1) 34 - 5	
					O-RING (4) 34 - 2	
					O-RING (2) 11 - 36	
					O-RING (2) 34 - 24	
					O-RING (2) 3 - 6	
					SEAL, THERMAL (1) 34 - 7	
13	PAHZZ	2940-01-184-1877	34623	5739124	FILTER, FLUID	1
					BRACKET, ANGLE (1) 35 - 2	
					FILTER ELEMENT, FLUI (1) 35 - 9	
14	PAFZZ	2930-01-287-9733	15434	380171000	PARTS KIT, ENGINE WA	1
					BEARING, BALL, ANNULA (2) 36 - 16	
					GASKET (1) 36 - 30	
					GASKET (2) 36 - 8	
					PACKING WITH RETAIN (2) 36 - 3	
					RING, BEARING RETAIN (1) 36 - 11	
15	PAFZZ	2930-01-262-5153	15434	380171200	PARTS KIT, ENGINE WA	1
					GASKET (1) 36 - 30	
					IMPELLER, PUMP, CENTR (1) 36 - 2	
					PACKING WITH RETAIN (2) 36 - 3	
					SHAFT, SHOULDERED (1) 36 - 7	
					SPACER (1) 36 - 10	

END OF FIGURE

(1) ITEM NO	(2) SMR CODE	(3) NSN	(4) CAGEC	(5) PART NUMBER	(6) DESCRIPTION AND USABLE ON CODE(UOC)	(7) QTY
					GROUP 95 BULK GROUP 9501 BULK MATERIAL	
					FIG. BULK	
1	PAOZZ	4720-00-541-4243	24161	28430	HOSE, NONMETALLIC	V
2	PAOZZ	4720-01-114-7728	19207	8710557	HOSE, NONMETALLIC	V
3	PAOZZ	4720-00-187-4102	01276	2580-6	HOSE, NONMETALLIC	V
					END OF FIGURE	

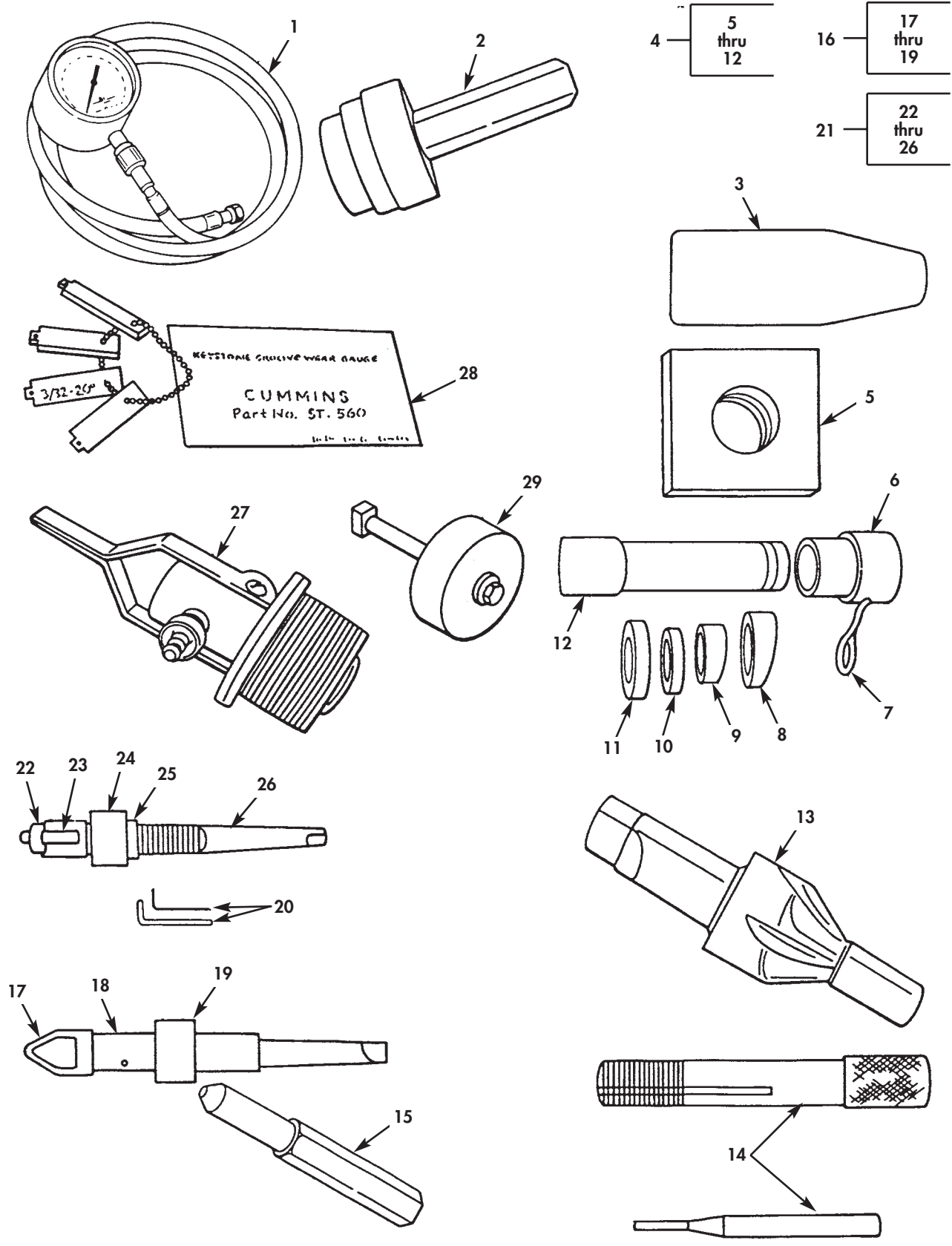


Figure 37. Direct Support Special Tools-1.

(1) ITEM NO	(2) SMR CODE	(3) NSN	(4) CAGEC	(5) PART NUMBER	(6) DESCRIPTION AND USABLE ON CODE(UOC)	(7) QTY
GROUP 2604 SPECIAL TOOLS						
FIG. 37 DIRECT SUPPORT SPECIAL TOOLS-1						
1	PEFZZ	6620-01-147-9954	15434	ST-1273	GAGE,PRESSURE,DIAL MANIFOLD PRESSURE.....	
2	PEFZZ	4910-01-097-6989	15434	3375180	DRIVER WATER PUMP.....	
3	PEFZZ	5120-00-896-8097	0B8S3	3822505	INSERTER,SEAL.....	
4	PEFZZ	4910-01-098-1914	15434	ST-1242	PARTS KIT BUSHING D.....	
5	PEHZZ	4910-01-112-7509	15434	ST-1242-3	.TOOL,EMBEDDING BLOC.....	
6	PEHZZ	4910-01-113-1066	15434	ST-1242-2	.CUP,BUSHING DRIVER.....	
7	PEHZZ	5315-01-110-7835	15434	ST-1242-6	.PIN,COTTER.....	
8	PEHZZ	5120-01-119-2743	15434	ST-1242-4	.DRIVER,BEARING AND.....	
9	PEHZZ	4910-01-099-1487	15434	ST-1242-5	.KNOCK OUT RING TAPE.....	
10	PEHZZ	4910-01-117-4885	15434	ST-1242-7	.RING,KNOCK OUT.....	
11	PEHZZ	4910-01-118-2878	15434	ST-1242-8	.DRIVER,BEARING AND.....	
12	PEHZZ	4910-01-108-9130	15434	ST-1242-1	.MANDREL.....	
13	PEFZZ	5133-00-932-2089	15434	ST-788	CUTTING TOOL,BEAD.....	
14	PEFZZ	4910-00-150-5858	15434	3375425	EXTRACTOR,SLEEVE IN.....	
15	PEFZZ	5120-00-981-3108	15434	ST-1227	INSTALLER,SLEEVE.....	
16	PEFZZ	4910-00-981-3105	15434	ST-884	CUTTER,INJECTOR SLE.....	
17	PEFZA	4910-01-097-6957	15434	ST-884-1	.HOLDER.....	
18	PEFZA	4910-01-098-5088	15434	ST-884-3	.CUTTER.....	
19	PEFZA	4910-01-097-6958	15434	ST-884-6	.PILOT.....	
20	PEFZZ	5120-00-150-7492	15434	ST-995	WRENCH,INJECTOR CUP INJECTOR CUP...	
21	PEFZZ	3441-00-922-6699	15434	ST-880	EXPANDER,TUBE.....	
22	PEFZZ	5210-01-099-6339	15434	ST-880-1	.GAGE.....	
23	PEFZZ	4910-01-097-6955	15434	ST-880-2	.ROLL.....	
24	PEFZZ		15434	ST-880-3	.COLLAR.....	
25	PEFZZ	5310-01-104-4549	15434	ST-880-6	.NUT.....	
26	PEFZZ	4910-01-097-6956	15434	ST-880-7	.MANDREL.....	
27	PEFZZ	4910-01-085-9211	15434	3375150	CHECKING TOOL,BLOWB.....	
28	PEFZZ	5210-00-999-1209	15434	ST-560	GAGE,PISTON RING GR.....	
29	PEFZZ	5120-00-104-1795	15434	ST-1179	HOLDING TOOL,INJECT.....	

END OF FIGURE

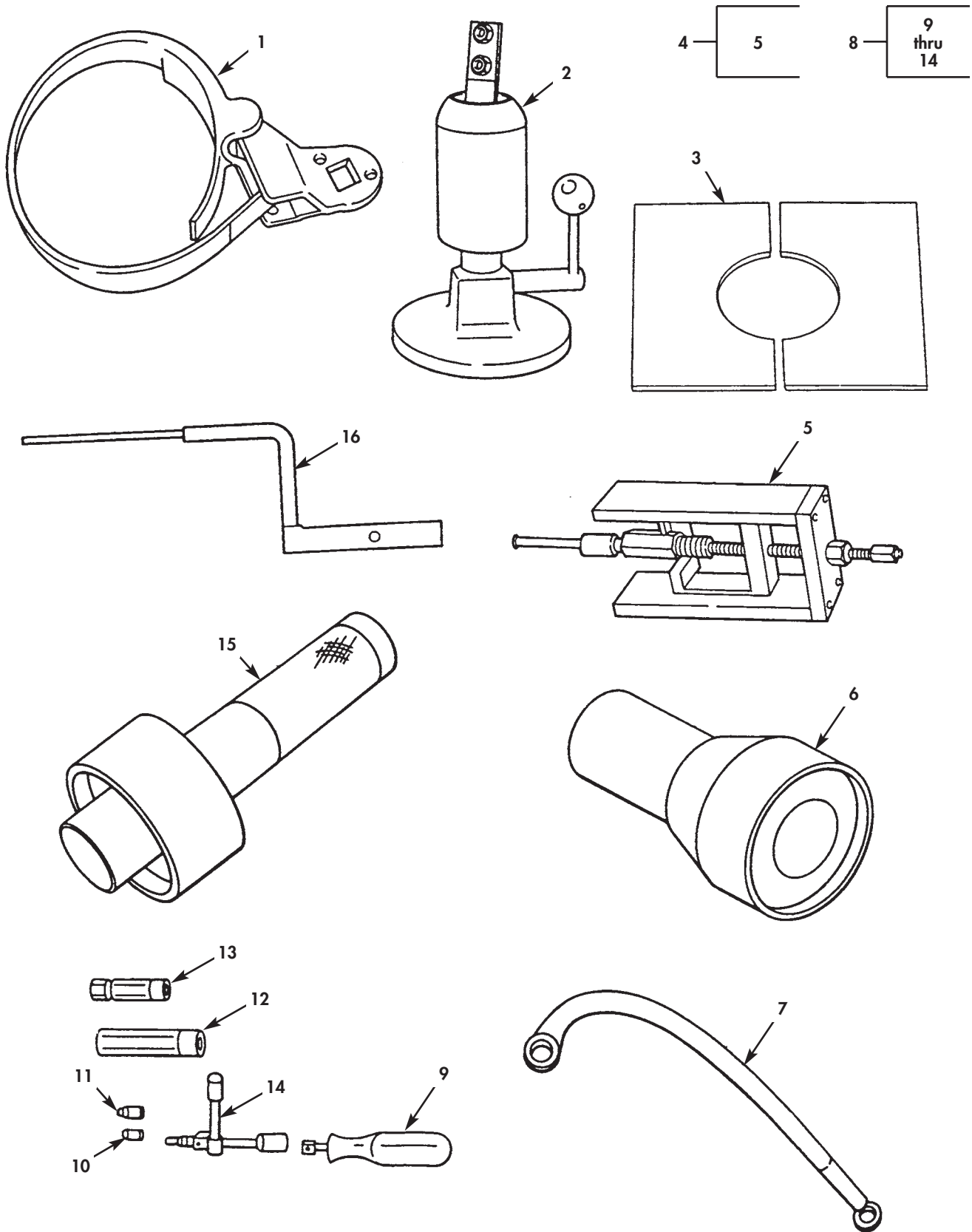


Figure 38. Direct Support Special Tools-2.

(1) ITEM NO	(2) SMR CODE	(3) NSN	(4) CAGEC	(5) PART NUMBER	(6) DESCRIPTION AND USABLE ON CODE(UOC)	(7) QTY
GROUP 2604 DS SPECIAL TOOLS						
FIG. 38 DIRECT SUPPORT SPECIAL TOOLS-2						
1	PEFZZ	5120-01-160-8863	0B8S3	3397929	WRENCH,STRAP OIL AND FUEL FILTER, SPIN-ON.....	
2	PEFZZ	4910-00-999-1506	15434	ST-302	WISE,BALL JOINT.....	
3	PEFZZ	4910-01-097-6987	15434	ST-1114	FIXTURE BEARING.....	
4	PEFZZ	5120-00-999-1504	63704	2380	PULLER,MECHANICAL GOVERNOR WEIGHT..	
5	PEFZZ	4910-01-097-6930	15434	3375108	.PULLER BUSHING.....	
6	PEFZZ	4910-01-097-6989	15434	3375180	DRIVER WATER PUMP.....	
7	PEFZZ	5120-01-072-2952	15434	3376845	WRENCH,BOX AND OPEN AIR COMPRESSOR..	
8	PEFFZ	5120-00-103-4687	15434	ST-669	ADAPTER,TORQUE WREN TORQUE WRENCH..	
9	PEFZZ		55719	F40B	.HANDLE,SOCKET WRENC.....	
10	PEFZZ	5120-01-122-6014	15434	ST-669-13	.SCREWDRIVER BIT.....	
11	PEFZZ	5120-00-865-0226	15434	TM-82	.BIT,SCREWDRIVER.....	
12	PEFZZ		15434	M-1302B-24	.SOCKET.....	
13	PEFZZ		15434	M1302B18	.SOCKET.....	
14	PEFZZ		15434	ST-6991	.DRIVER.....	
15	PEFZZ	4910-01-097-6988	15434	ST-1159	MANDREL,SEAL,SLEEVE SEAL-WEAR SLEEVE.....	
16	PEFZZ	4910-01-097-6972	15434	ST-1325	ATTACHMENT DIAL.....	

END OF FIGURE

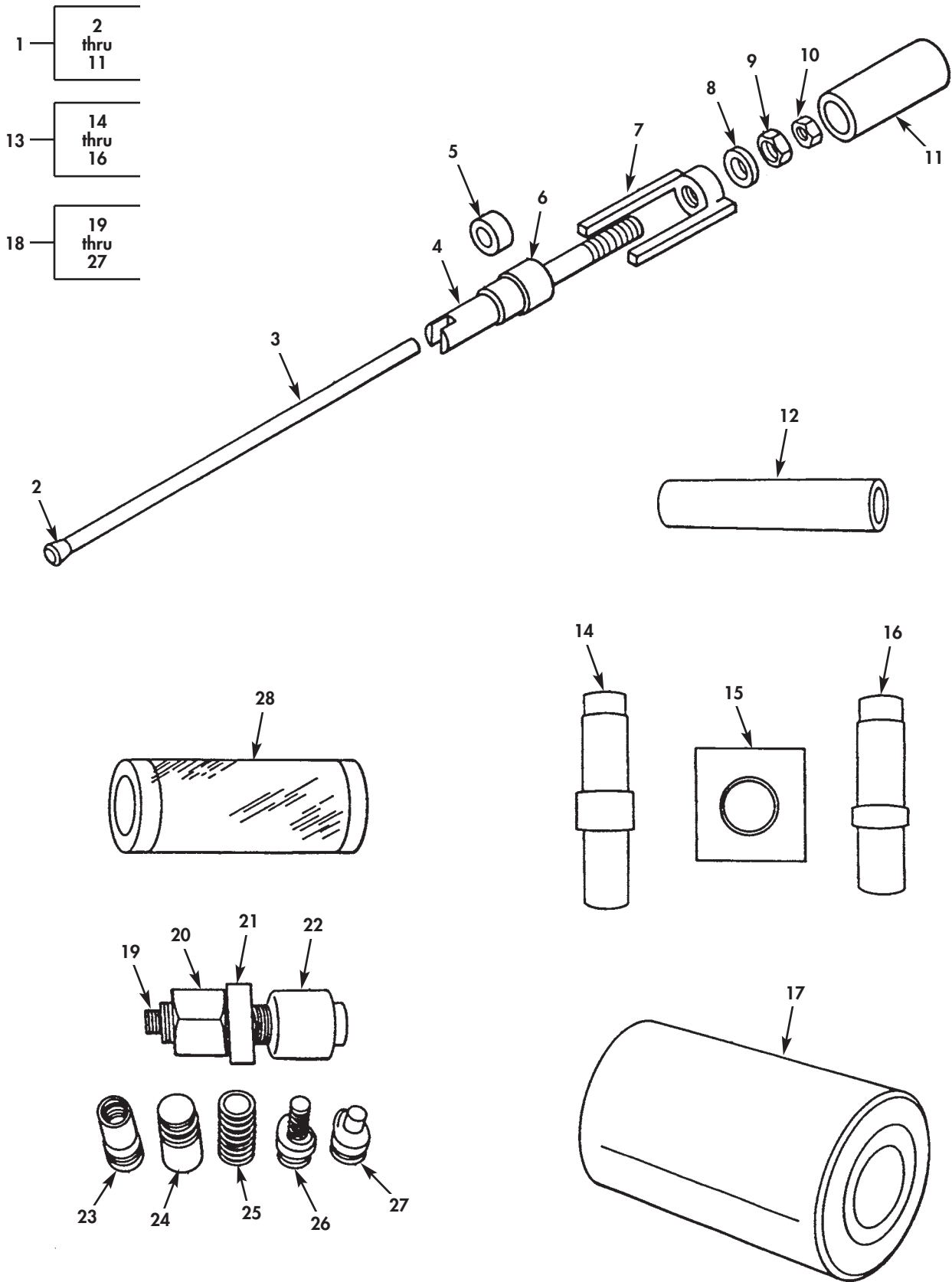


Figure 39. Direct Support Special Tools-3.

(1) ITEM NO	(2) SMR CODE	(3) NSN	(4) CAGEC	(5) PART NUMBER	(6) DESCRIPTION AND USABLE ON CODE(UOC)	(7) QTY
GROUP 2604 SPECIAL TOOLS-3						
FIG. 39 DIRECT SUPPORT SPECIAL TOOLS-3						
1	PEFZZ	5120-00-113-5271	0B8S3	3377079	PULLER,MECHANICAL.....	
2	PEFZZ	4910-01-097-6970	15434	3375825	.TIP EXTRACTOR.....	
3	PEFZZ	5120-01-120-3682	15434	3375616	.ROD,INJECTOR SLEEVE.....	
4	KFFZZ		15434	3375615	.COLLAR.....	
5	PEFZA	4910-01-097-6969	15434	3375614	.COLLAR FORMING.....	
6	PEFZZ	5365-01-103-7835	15434	ST-1244-9	.SPACER,RING.....	
7	PEFZZ		15434	ST-1244-1	.SUPPORT.....	
8	PEFZZ	3120-01-103-8752	15434	ST-1244-5	.BEARING,WASHER,THRU.....	
9	PEFZZ	5310-01-104-4550	15434	ST-1244-4	.NUT.....	
10	PEFZZ		15434	ST-1244-3	.NUT.....	
11	PEFZZ	5120-01-099-6341	15434	ST-1244-8	.HAMMER,HAND.....	
12	PEFZZ	4910-01-097-6971	15434	3375282	DRIVER VALVE GUIDE.....	
13	PEFFF	3460-00-999-1210	15434	ST-691	MANDREL SET,MACHINE.....	
14	PEFZZ		15434	ST-691-1	.MANDREL.....	
15	PEFZZ		15434	ST-691-2	.BLOCK.....	
16	PEFZZ		15434	ST691-3	.MANDREL.....	
17	PEFZZ	4910-01-097-6986	15434	ST-658	MANDREL WATER PUMP.....	
18	PEFZZ	5120-01-156-4183	15434	3376326	PULLER,MECHANICAL PULLEY INSTALLATION.....	
19	PEFZZ	4910-01-097-6977	15434	ST-386-2	.ARBOR.....	
20	PEFZZ	5310-01-097-6978	15434	ST-386-3	.NUT,PLAIN,HEXAGON.....	
21	PEHZZ	4910-01-097-6984	15434	ST-386-11	.BALL THRUST BEARING.....	
22	PEFZZ	4910-01-097-6979	15434	ST-386-5	.SPACER.....	
23	PEFZZ	4910-01-097-6985	15434	3375205	.ADAPTER.....	
24	PEFZZ	4910-01-097-6983	15434	ST-386-10	.ADAPTER.....	
25	PEFZZ	4910-01-097-6982	15434	ST-386-9	.ADAPTER.....	
26	PEFZZ	4910-01-097-6981	15434	ST-386-8	.ADAPTER.....	
27	PEFZZ	4910-01-097-6980	15434	ST-386-6	.ADAPTER.....	
28	PEFZZ	4910-00-150-5797	15434	ST-633	HEAD,GUIDE,SPACER.....	

END OF FIGURE

3 — 4
thru
14

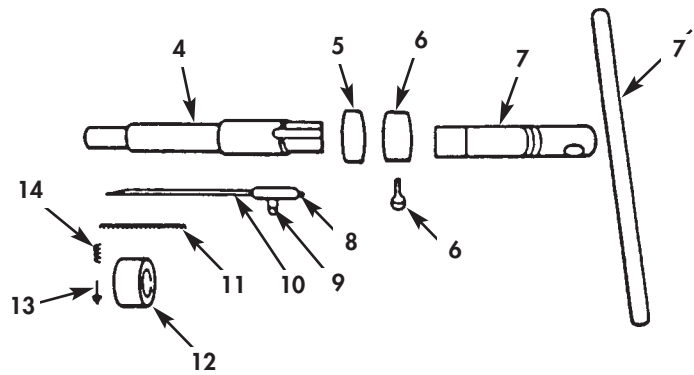
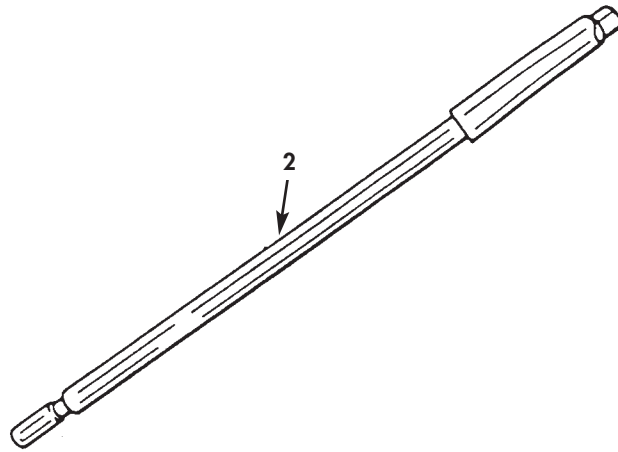
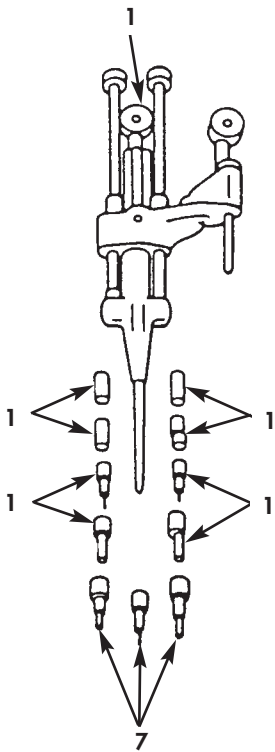


Figure 40. Direct Support Special Tools (Supplemental), Big Cam I (Sheet 1 of 2).

16 — 17
thru
20

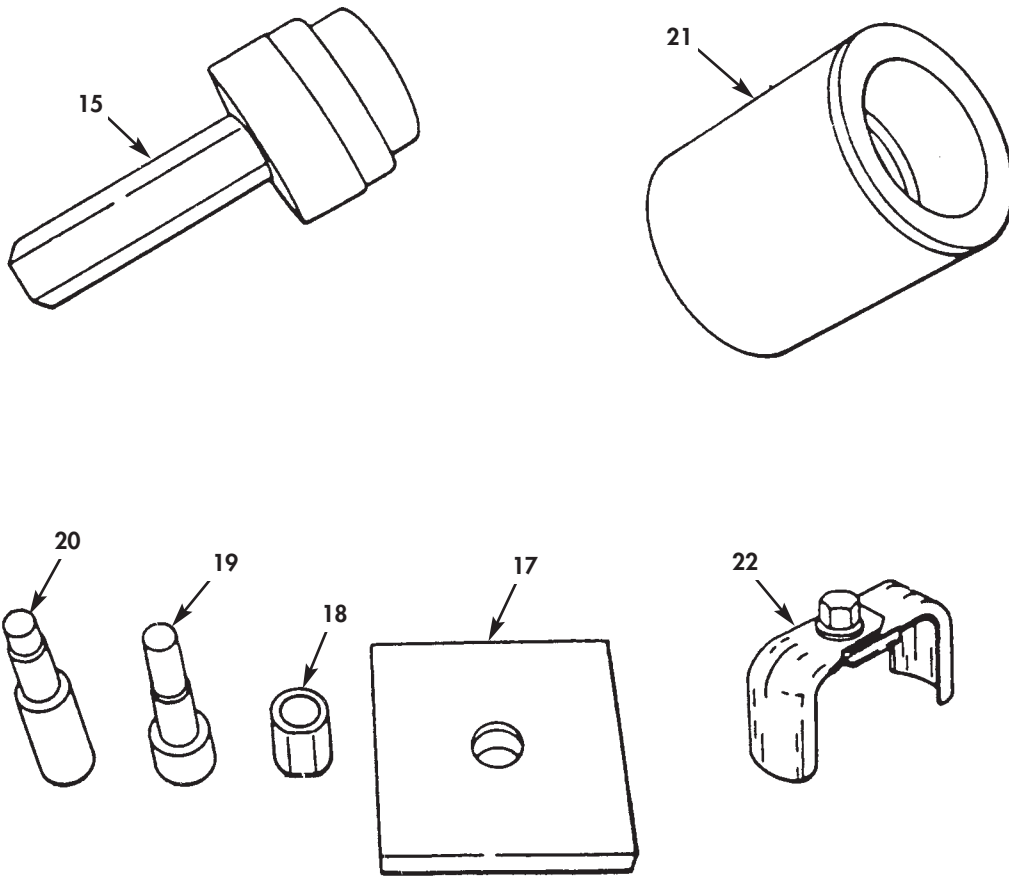


Figure 40. Direct Support Special Tools (Supplemental) Big Cam I (Sheet 2 of 2).

(1) ITEM NO	(2) SMR CODE	(3) NSN	(4) CAGEC	(5) PART NUMBER	(6) DESCRIPTION AND USABLE ON CODE(UOC)	(7) QTY
GROUP 2604 SPECIAL TOOLS						
FIG. 40 DIRECT SUPPORT SPECIAL TOOLS (SUPPLEMENTAL) BIG CAM I						
1	PEFZZ		15434	ST593	INDICATOR,ENGINE TI	
2	PEFZZ	5110-00-980-7347	0B8S3	3376464	REAMER,HAND	
3	PEFZZ	5120-00-178-0948	15434	ST-1100	TOOL,GROOVING	
4	PEFZZ	4910-01-097-6964	15434	ST-1100-10	.BODY	
5	PEFZZ	5310-01-097-6961	15434	ST-1100-7	.NUT,PLAIN,KNURLED	
6	XAFZZ		15434	ST-1100-5	.NUT,PLAIN,KNURLED	
7	XAFZZ		15434	ST-1100-1	.NUT,PLAIN,KNURLED	
8	PEFZZ	4910-01-097-6962	15434	ST-1100-8	.SLEEVE ROD	
9	PEFZZ	4910-01-097-6960	15434	ST-1100-6	.CAPS CREW	
10	PEFZZ	4910-01-097-6965	15434	ST-1100-11	.ROD TOOL ADJUSTING	
11	PEFZZ	4910-01-097-6963	15434	ST-1100-9	.SPRING ROD	
12	PEFZZ	4910-01-097-6968	15434	ST-1100-14	.CAP TOOL SETTING	
13	PEFZZ		15434	ST-1100-13	.HONING UNIT,CYLINDR	
14	PEFZA	4910-01-097-6966	15434	ST-1100-12	.SPRING TOOL	
15	PEFZZ	4910-01-097-6976	15434	ST-1218	MANDREL O RING	
16	PEFZZ	5180-00-916-1813	15434	ST-249	MANDREL-BLOCK,CAM F	
17	XAFZZ		15434	ST-249-4	.BLOCK	
18	PEFZZ	5120-01-106-9174	15434	ST-249-3	.SLEEVE,MANDREL	
19	PEFZZ	5120-01-097-3204	15434	ST-249-2	.MANDREL	
20	PEFZZ	5120-01-106-9173	15434	ST-249-1	.MANDREL	
21	PEFZZ	5120-00-159-8916	15434	ST-659	INSERTER,SEAL	
22	PEFZZ		93389	2304	REMOVAL TOOL,OIL FI	
KIT	ADFFF	5180-01-071-0707	19207	5704993	TOOL KIT,GENERAL ME	

END OF FIGURE

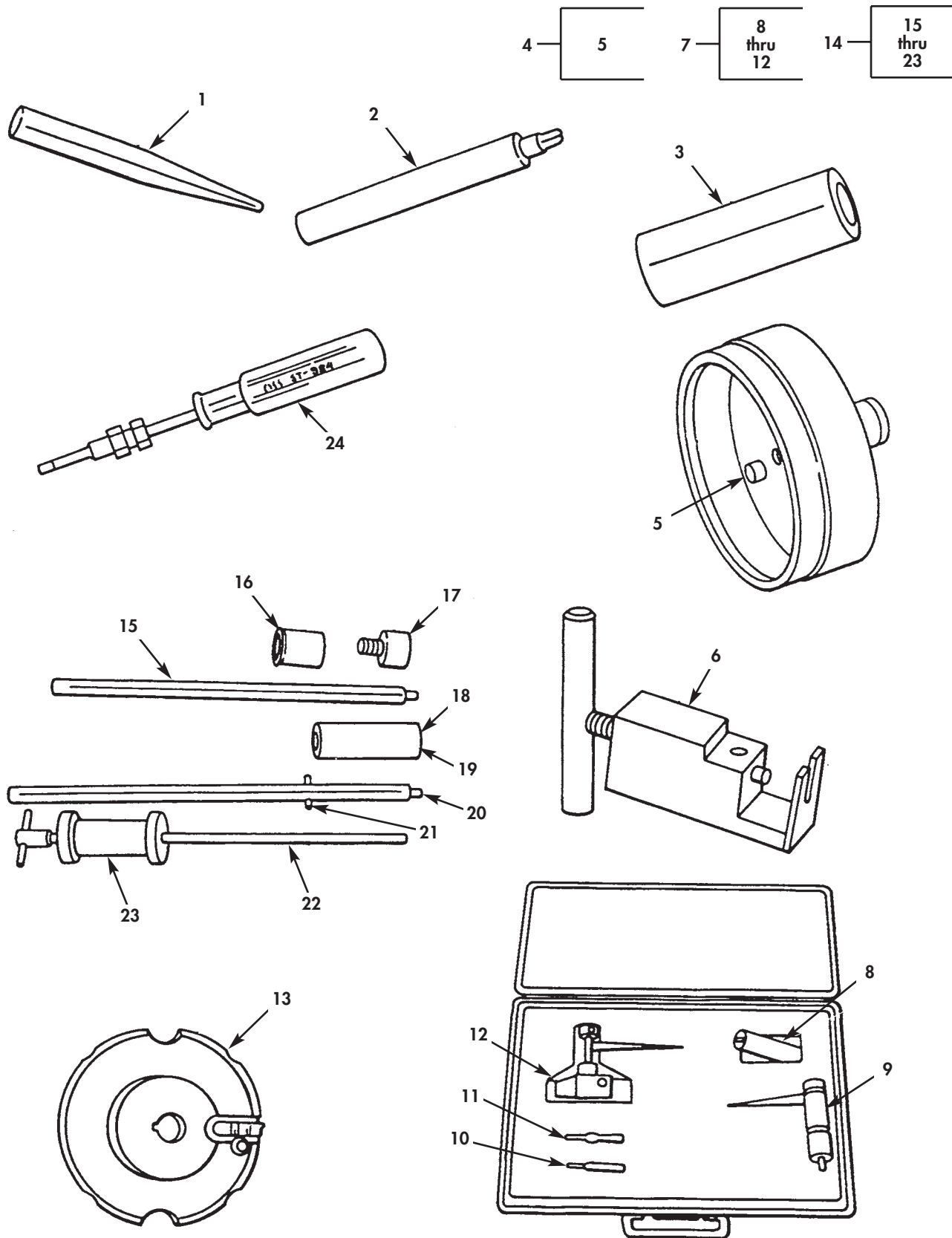


Figure 41. General Support Common Tools-1.

(1) ITEM NO	(2) SMR CODE	(3) NSN	(4) CAGEC	(5) PART NUMBER	(6) DESCRIPTION AND USABLE ON CODE(UOC)	(7) QTY
GROUP 2604 SPECIAL TOOLS						
FIG. 41 GENERAL SUPPORT SPECIAL TOOLS-1						
1	PEHZZ	5120-00-999-1505	15434	ST-835	INSERTER, PREFORMED.....	
2	PEHZZ	4910-00-150-5801	15434	ST-853	DRIVER, GOVERNOR, CYL.....	
3	PEHZZ	5120-00-896-8087	0B8S3	ST-1032	INSERTER, SEAL.....	
4	PEFZZ	5120-00-150-5810	0B8S3	3824211	INSERTER, SEAL.....	
5	PEHZZ	4910-01-097-6915	15434	ST-997-6	.PINS.....	
6	PEHZZ	4910-01-118-3747	15434	3375204	THROTTLE SHAFT BALL.....	
7	PEHZZ	5180-01-102-8418	0B8S3	3823114	TOOL KIT, FUEL PUMP.....	
8	PEHZZ	5305-01-097-6921	15434	ST-1259-6	.SCREW, CAP, HEXAGON H.....	
9	PEHZZ	4910-01-097-6940	15434	3375140	.TOOL AFC NO AIR ADJ.....	
10	PEHZZ	4910-01-097-6941	15434	3375146	.INSTALLING TOOL.....	
11	XAHZZ		15434	3375147	.FORMING TOOL.....	
12	PEHZA	4910-01-097-6939	15434	3375137	.TOOL AFC ADJUSTING.....	
13	PEHZZ		15434	ST1065	HOLDER, TOOL.....	
14	PEHHZ		59770	EST1228	MANDREL, CAMSHAFT BU.....	
15	PEHZZ	4910-01-098-1917	15434	ST-1228-3	.MANDREL SHANK BUSHI.....	
16	PEHZZ	4910-01-100-6191	15434	ST-1228-9	.DRIVER.....	
17	PEHZA	4910-01-097-6910	15434	ST-1228-13	.PULLEY ASSEMBLY BUS.....	
18	PEHZA	4910-01-098-1919	15434	ST-1228-5	.GUIDE BUSHING DRIVE.....	
19	PEHZZ	4910-01-097-6912	15434	3375154	.GUIDE.....	
20	PEHZA	4910-01-098-1918	15434	ST-1228-4	.SHAFT ASSEMBLY.....	
21	PEHZZ	4910-01-097-6911	15434	ST-1228-14	.ROLL PIN.....	
22	PEHZZ	4910-01-098-1916	15434	ST-1228-2	.ROD BUSHING DRIVER.....	
23	PEHZZ	4910-01-098-1915	15434	ST-1228-1	.HAMMER SLIDE.....	
24	PEHZZ	4910-00-150-5805	34623	MA326-21373	ADJUSTING TOOL.....	

END OF FIGURE

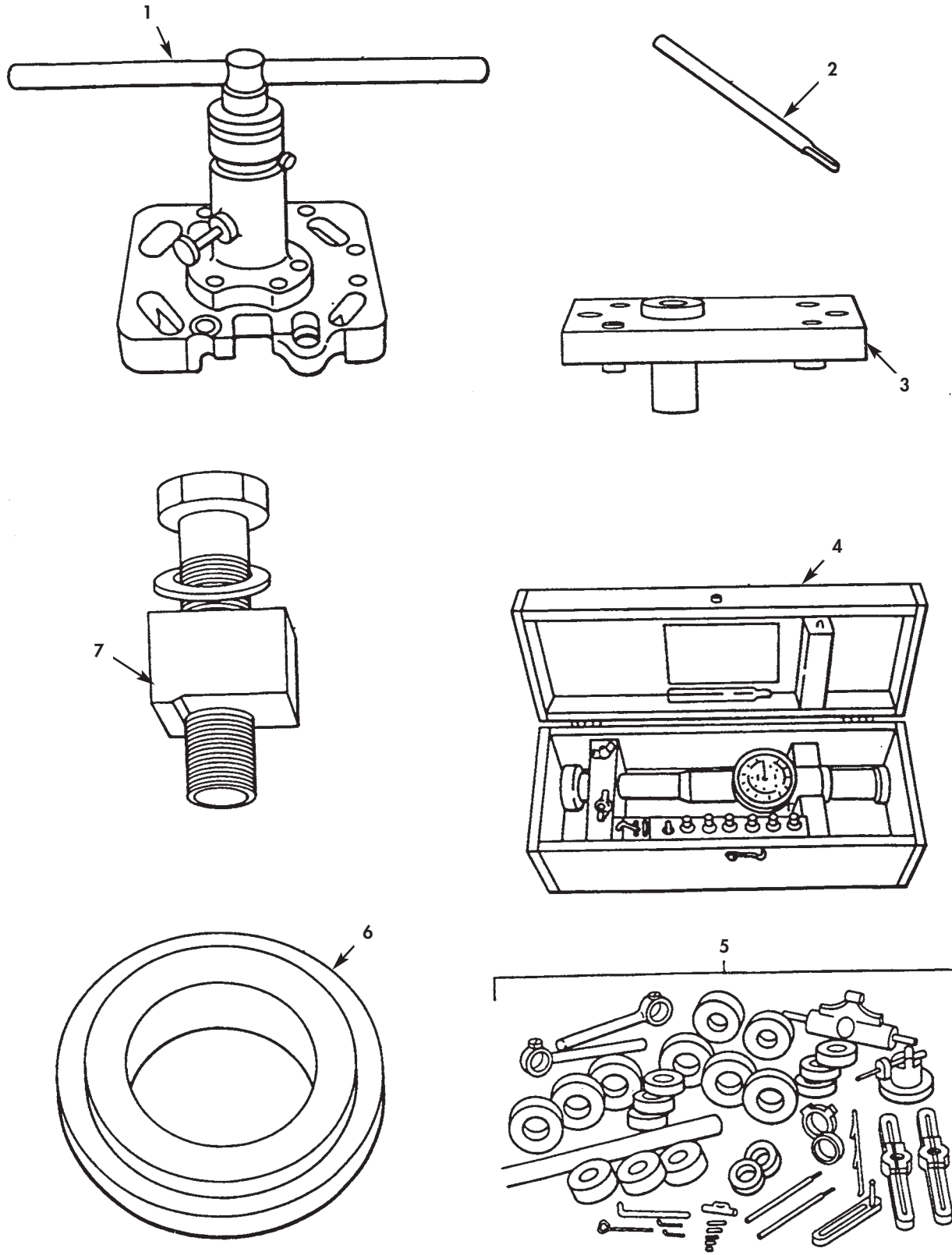


Figure 42. General Support Common Tools-2.

(1) ITEM NO	(2) SMR CODE	(3) NSN	(4) CAGEC	(5) PART NUMBER	(6) DESCRIPTION AND USABLE ON CODE(UOC)	(7) QTY
GROUP 2604 SPECIAL TOOLS						
FIG. 42 GENERAL SUPPORT SPECIAL TOOLS-2						
1	PEHZZ	5120-00-150-7488	0B8S3	3376684	COUNTERBORE TOOL,CY.....	
2	PEHZZ	5120-01-120-5760	15434	ST-1059-17	TOOL BIT,COUNTER.....	
3	PEHZZ	5110-00-981-3107	15434	3376903	REAMING FIXTURE,SHA.....	
4	PEHZZ	6625-01-232-5469	15434	3376619	PARTS KIT,GAGE TEST.....	
5	PEHZZ	5220-00-795-3079	15434	ST1177	GAGE,PROFILE.....	
6	PEHZZ	5220-01-168-6878	15434	ST-903	GAGE,RING,PLAIN.....	
7	PEHZZ		15434	3376669	CLAMP,CYLINDER LINE.....	
END OF FIGURE						

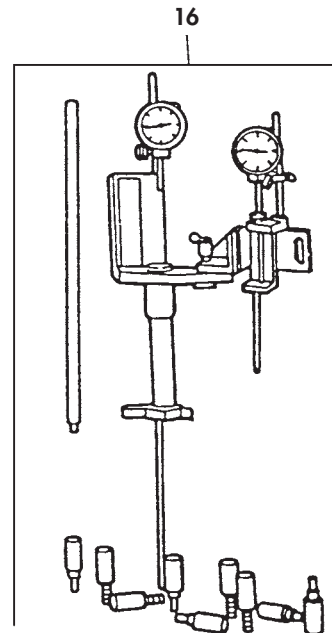
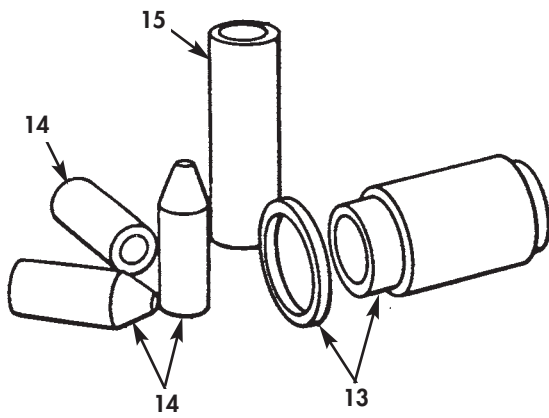
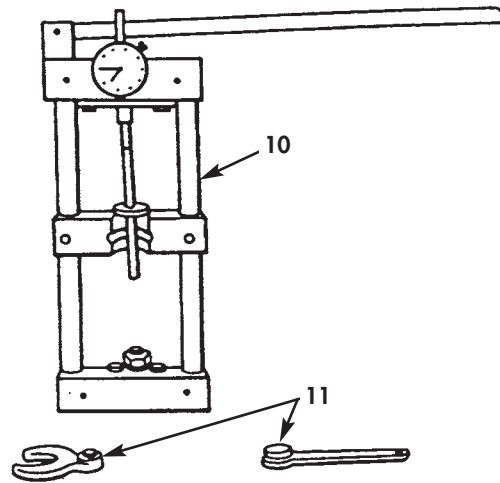
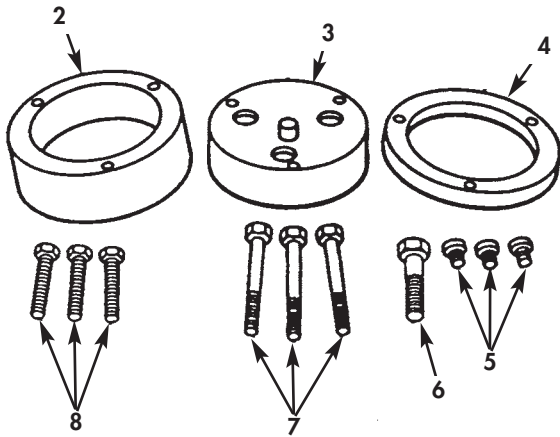
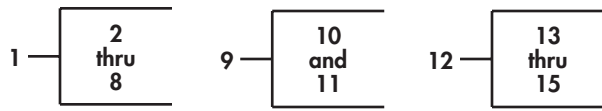


Figure 43. General Support Common Tools-3.

(1) ITEM NO	(2) SMR CODE	(3) NSN	(4) CAGEC	(5) PART NUMBER	(6) DESCRIPTION AND USABLE ON CODE(UOC)	(7) QTY
GROUP 2604 SPECIAL TOOLS						
FIG. 43 GENERAL SUPPORT SPECIAL TOOLS-3						
1	PEHHH	4910-01-106-0492	15434	ST-1259	PULLER-INSTALLER OIL SEAL.....	
2	PEHZZ	4910-01-097-6919	15434	ST-1259-4	.TOOL SPACER RING OIL SEAL.....	
3	PEHZZ	4910-01-097-6916	15434	ST-1259-1	.PLATE TOP OIL SEAL.....	
4	PEHZA	4910-01-097-6917	15434	ST-1259-2	.TOOL SPACER RING OIL SEAL.....	
5	PEHZZ	5305-01-097-6918	15434	ST-1259-3	.SETSCREW OIL SEAL.....	
6	PEHZZ	5305-01-098-1913	15434	ST-1259-7	.SCREW,CAP,HEXAGON H OIL SEAL.....	
7	PEHZZ	5305-01-097-6920	15434	ST-1259-5	.SETSCREW OIL SEAL.....	
8	PEHZZ	5305-01-097-6921	15434	ST-1259-6	.SCREW,CAP,HEXAGON H OIL SEAL.....	
9	PEHZZ	4910-01-097-6926	15434	3822696	FIXTURE TOP STOP TOP STOP INJECTOR..	
10	PEHZZ	4910-01-097-6927	15434	3375165	.TOOL ADJUSTING TOP STOP INJECTOR..	
11	PEHZZ	4910-01-097-6928	15434	3375166	.WRENCH CROWSFOOT TOP STOP INJECTOR	
12	PEHZZ	5180-01-074-0019	0B8S3	3822472	TOOL KIT,FUEL PUMP FRONT COVER AND MAIN SHAFT ASSEMBLY.....	
13	PEHZZ	4910-01-097-6936	15434	3375172	.INSTALLING TOOL FRONT COVER AND MAIN SHAFT ASSEMBLY.....	
14	PFHZZ	4910-01-097-6937	15434	3375173	.DRIVER MAIN SHAFT FRONT COVER AND MAIN SHAFT ASSEMBLY.....	
15	PEHZZ	4910-01-097-6938	15434	3375174	.DRIVER FRONT COVER FRONT COVER AND MAIN SHAFT ASSEMBLY.....	
16	PEHZZ		15434	3824942	TESTER,INTERNAL COM INJECTION TIMING.....	
KIT	ADHHH	5180-01-141-9274	19207	5704991	TOOL KIT,GENERAL ME.....	

END OF FIGURE

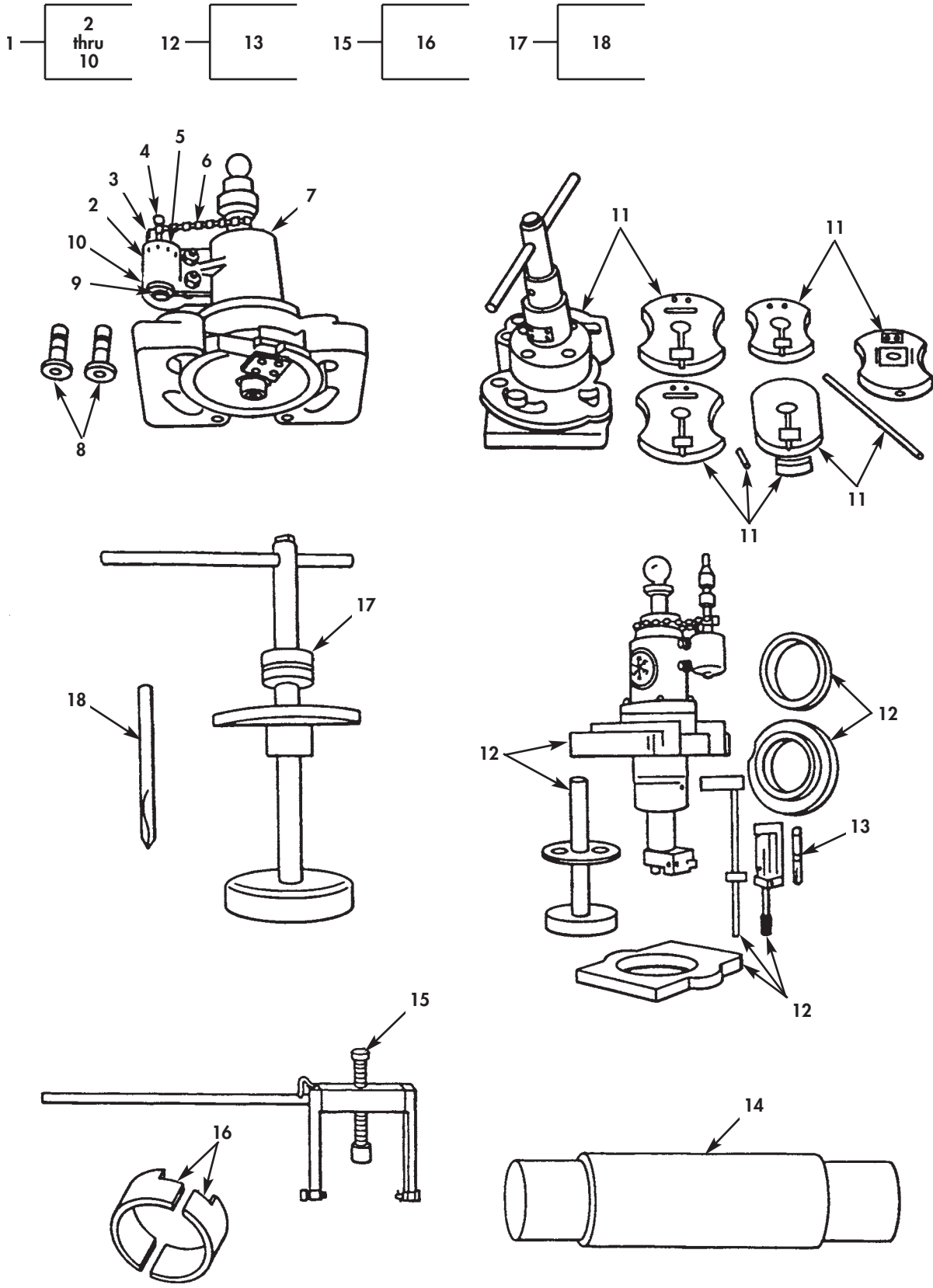


Figure 44. General Support Special Tools-1 (Supplemental), Big Cam I.

(1) ITEM NO	(2) SMR CODE	(3) NSN	(4) CAGEC	(5) PART NUMBER	(6) DESCRIPTION AND USABLE ON CODE(UOC)	(7) QTY
GROUP 2604 SPECIAL TOOLS						
FIG. 44 GENERAL SUPPORT SPECIAL TOOLS-1 (SUPPLEMENTAL) BIG CAM I						
1	PEHHH	4910-01-085-1011	15434	ST-1168	BORING MACHINE, ENGI COUNTER BORE, GENERAL SUPPORT SPECIAL TOOLS	
2	PEHZZ	3120-01-085-0762	15434	ST-1168-4	.BEARING, DRIVE.....	
3	PEHZZ	5305-01-084-4596	15434	ST-1168-6	.SETSCREW.....	
4	PEHZZ	4910-01-085-0763	15434	ST-1168-3	.SHAFT, CHAIN DRIVE.....	
5	PAHZZ	3020-01-085-0761	15434	ST-1168-5	.SPROCKET WHEEL SEGM.....	
6	PAHZZ	3020-01-084-7007	15434	ST-1168-7	.CHAIN, ROLLER.....	
7	PEHZZ	3020-01-086-8269	15434	ST-1168-10	.SPROCKET, DRIVEN.....	
8	PEHZZ	4910-01-098-1912	15434	ST-1168-19	.TOOL BIT.....	
9	PEHZZ	4910-01-086-8268	15434	ST-1168-8	.SNAP RING, SHAFT.....	
10	PAHZZ	4910-01-088-7904	15434	ST-1168-9	.SNAP RING, BEARING.....	
11	PEHZZ	5120-00-065-1031	15434	ST-544	PULLER, MECHANICAL.....	
12	PEHZZ	4910-01-085-0765	15434	3376904	BORING TOOL, CYLINDE.....	
13	PEHZZ	5133-01-084-6008	15434	ST-1287-10	.TOOL BIT.....	
14	PEHZZ	4910-01-097-6914	15434	ST-1158	BUSHING MANDREL.....	
15	PEHZZ	5120-01-120-5759	15434	3375834	GEAR PULLER ASSEMBL.....	
16	PEHZZ	4910-01-097-6909	15434	3375839	.PULLER JAW.....	
17	PEHZZ	4910-01-085-0766	15434	ST-1318	CHAMFER TOOL, LOWER.....	
18	PEHZZ	5133-01-084-6009	15434	ST-1318-23	.BIT, LOWER LINER.....	

END OF FIGURE

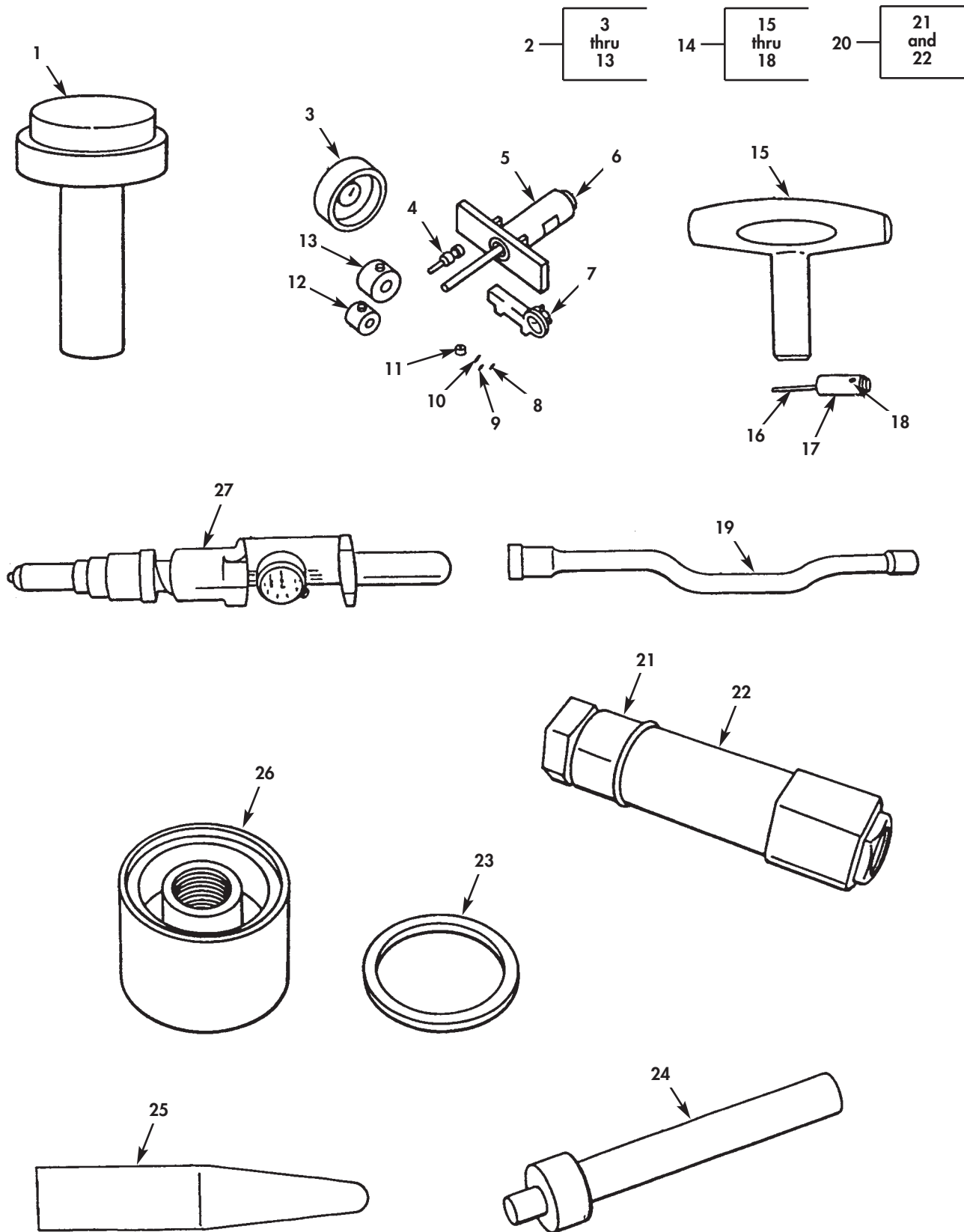


Figure 45. General Support Special Tools-2 (Supplemental), Big Cam I.

(1) ITEM NO	(2) SMR CODE	(3) NSN	(4) CAGEC	(5) PART NUMBER	(6) DESCRIPTION AND USABLE ON CODE(UOC)	(7) QTY
GROUP 2604 SPECIAL TOOLS						
FIG. 45 GENERAL SUPPORT SPECIAL TOOLS-2 (SUPPLEMENTAL) BIG CAM I						
1	PEHZZ	4910-01-105-9165	15434	3375153	DRIVER.....	
2	PEHHH	4910-01-085-7824	34623	MA326 21 180	BORING TOOL,BUSHING.....	
3	PAHZZ	4910-01-085-0751	15434	3375223	.GUIDE,BUSHING BORIN.....	
4	PEHZZ	4910-01-084-6979	15434	3375229	.DRIVE ADAPTER,BORTO.....	
5	PEHZZ	4930-01-085-3728	15434	3375220	.HOUSING,BORING TOOL.....	
6	PEHZZ	5355-01-097-7072	15434	3375228	.KNOB.....	
7	PEHZZ		15434	3375227	.DIAL,INDICATOR.....	
8	PEHZZ		15434	3375226	.BIT,BORING TOOL,BUS.....	
9	PAHZZ	4910-01-084-7222	15434	3375225	.CUTTER BIT,BORING M.....	
10	PAHZZ	4910-01-084-7221	15434	3375207	.CUTTER BIT,BORING M.....	
11	PEHZZ	5355-01-084-5323	15434	3375224	.KNOB.....	
12	PEHZZ	4910-01-084-6977	15434	3375221	.GUIDE,BUSHING BORIN.....	
13	PEHZZ	4910-01-084-6978	15434	3375222	.GUIDE,BUSHING.....	
14	PEHZZ	5120-01-120-3681	15434	3376177	TORQUE WRENCH,INJEC.....	
15	PEHZZ	5120-01-072-2955	15434	ST-1090	.WRENCH,TORQUE.....	
16	PEHZZ	5305-01-097-6924	15434	ST-1090-4	.SET SCREW.....	
17	XAHZZ		15434	3376197	.SCREWDRIVER.....	
18	PEHZZ	4910-01-097-6923	15434	ST-1090-3	.WRENCH ALLEN.....	
19	PEHZZ	4910-01-097-6925	15434	ST-1145	TORQUING TOOL.....	
20	PEHHH	5120-01-097-6932	15434	ST-1326	PULLER SET,MECHANIC.....	
21	PEHZA	4910-01-097-6934	15434	ST-1326-2	.COLLAR.....	
22	PEHZZ	4910-01-097-6933	15434	ST-1326-1	.COLLET.....	
23	PEHZZ	5330-01-107-1841	15434	3375015	GASKET.....	
24	PEHZZ	4910-01-097-6944	15434	3375230	INSTALLING TOOL.....	
25	PEHZZ		15434	ST-422	INSERTER,PREFORMED.....	
26	PEHZA	4910-01-097-6935	15434	3375014	ADAPTER PLATE FUEL.....	
27	PEHZZ	4910-01-097-6931	15434	ST-1231	BLOCK WEIGHT.....	

END OF FIGURE

4 — 5 and 6

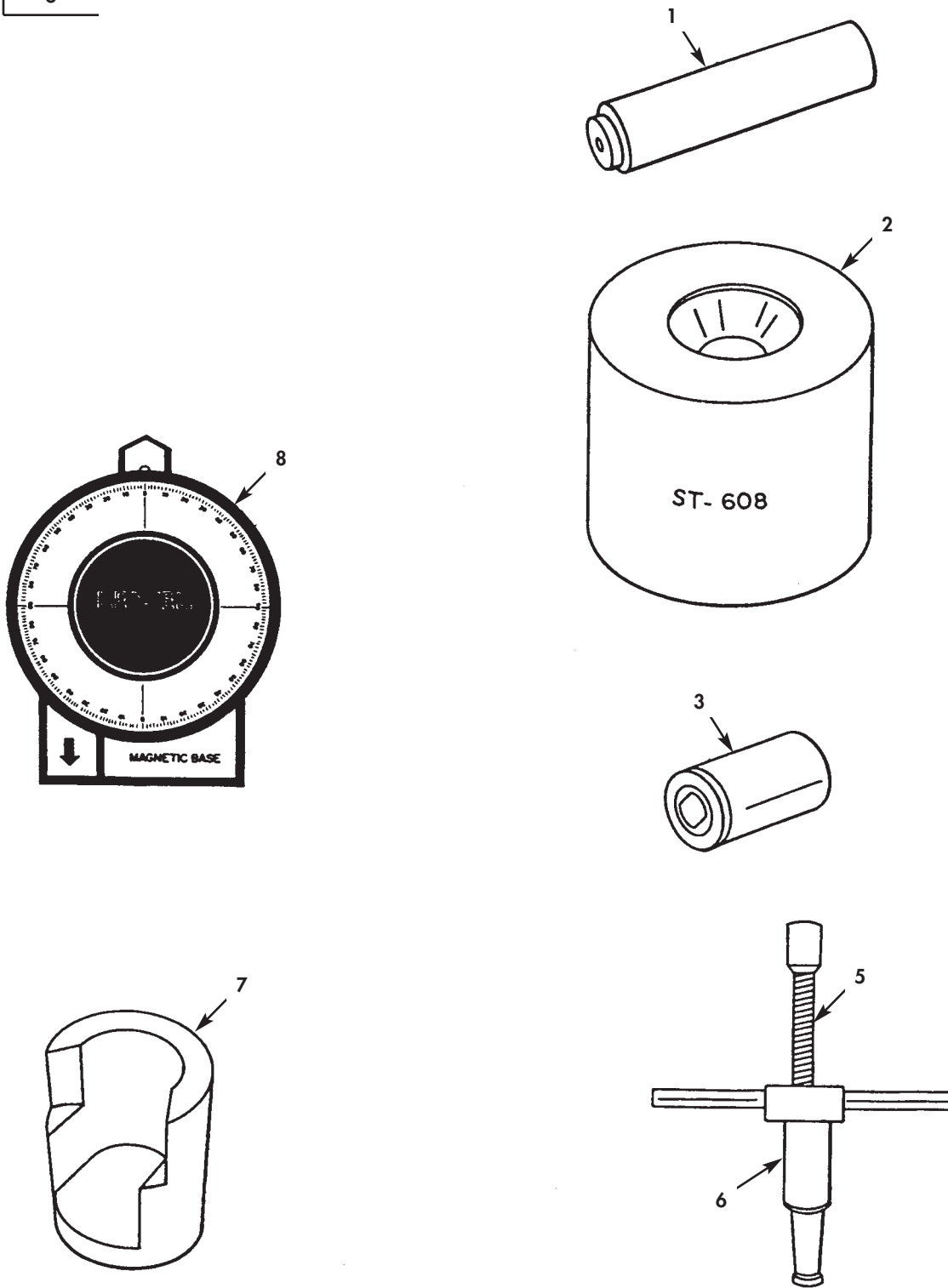


Figure 46. General Support Special Tools-3 (Supplemental).

(1) ITEM NO	(2) SMR CODE	(3) NSN	(4) CAGEC	(5) PART NUMBER	(6) DESCRIPTION AND USABLE ON CODE(UOC)	(7) QTY
GROUP 2604 SPECIAL TOOLS						
FIG. 46 GENERAL SUPPORT SPECIAL TOOLS-3 (SUPPLEMENTAL)						
1	PEHZZ	4910-01-097-6945	15434	3375271	MANDREL.....	
2	PEHZZ	4910-01-086-9766	15434	ST-608	TURBO SUPPORT BLOCK.....	
3	XDHZZ		15434	ST-1095	SOCKET, SOCKET WRENCH.....	
4	PEHZZ	5120-00-065-1031	15434	ST-544	PULLER, MECHANICAL.....	
5	XAHZZ		15434	ST-544-2	.SCREW VALVE.....	
6	PEHZZ	5120-01-100-0135	15434	ST-544-1	.REMOVER, BEARING AND.....	
7	PEHZZ	5120-00-923-0856	15434	ST-851	HOLDER.....	
8	PEHZZ	4910-01-074-0020	15434	3375855	TEMPLATE, FUEL PUMP LEVEL AND ANGLE.	
KIT	ADHHH	5180-01-141-9274	19207	5704991	TOOL KIT, GENERAL ME.....	
KIT	ADHHH	5180-01-069-6998	19207	5704994	TOOL KIT, GENERAL ME.....	
END OF FIGURE						

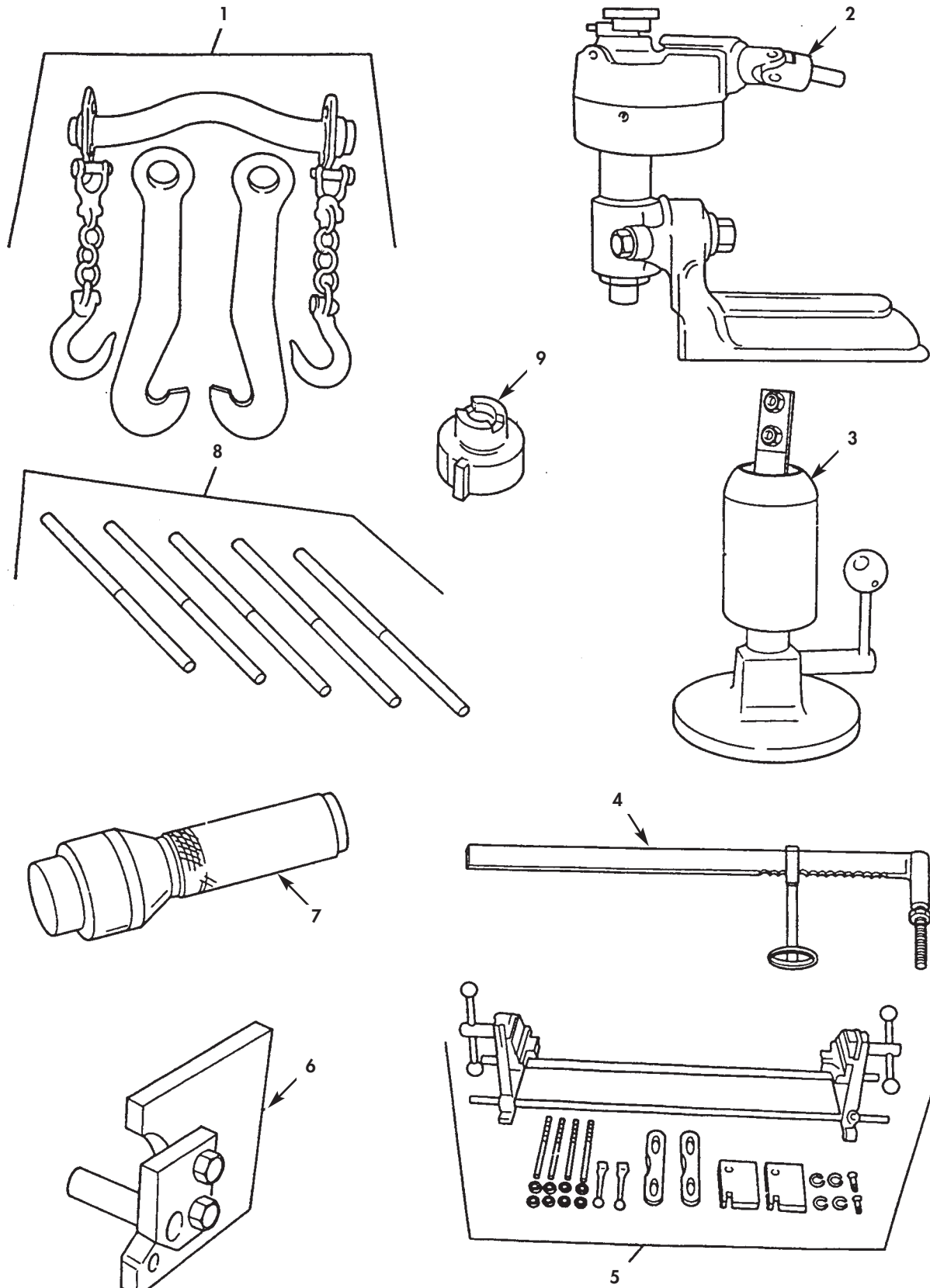


Figure 47. Direct and General Support Special Tools-1.

(1) ITEM NO	(2) SMR CODE	(3) NSN	(4) CAGEC	(5) PART NUMBER	(6) DESCRIPTION AND USABLE ON CODE(UOC)	(7) QTY
GROUP 2604 SPECIAL TOOLS						
FIG. 47 DIRECT AND GENERAL SUPPORT SPECIAL TOOLS-1						
1	PEFZZ	2815-00-362-2042	15434	ST-125	FIXTURE ENGINE LIFTING.....	
2	PEFZZ	4910-00-345-3708	15434	ST-257	INSERT KIT,VALVE SE VALVE SEAT INSERT.....	
3	PEFAA		OB8S3	ST-448	COMPRESSOR,VALVE SP.....	
4	PEFZZ	4920-00-711-9307	15434	ST583	FIXTURE,HOLDING,CYL.....	
5	PEHZZ	4910-01-150-9713	15434	3375455	BORING MACHINE,ENGI CYLINDER BLOCK COUNTERBORE.....	
6	PEFZZ	4910-01-159-8701	15434	ST-749	PLATE,MOUNTING,AIR AIR COMPRESSOR MOUNTING.....	
7	PEFZZ	5120-01-164-3265	OB8S3	ST-1105	INSERTER AND REMOVE AIR COMPRESSOR BUSHING.....	
8	PEFZZ	3460-00-999-1173	15434	ST-663	ARBOR SET,VALVE GUI.....	
9	PEFZZ	4910-00-999-1208	15434	ST662	CUTTER SET,COUNTERB VALVE SEAT INSERT.....	
END OF FIGURE						

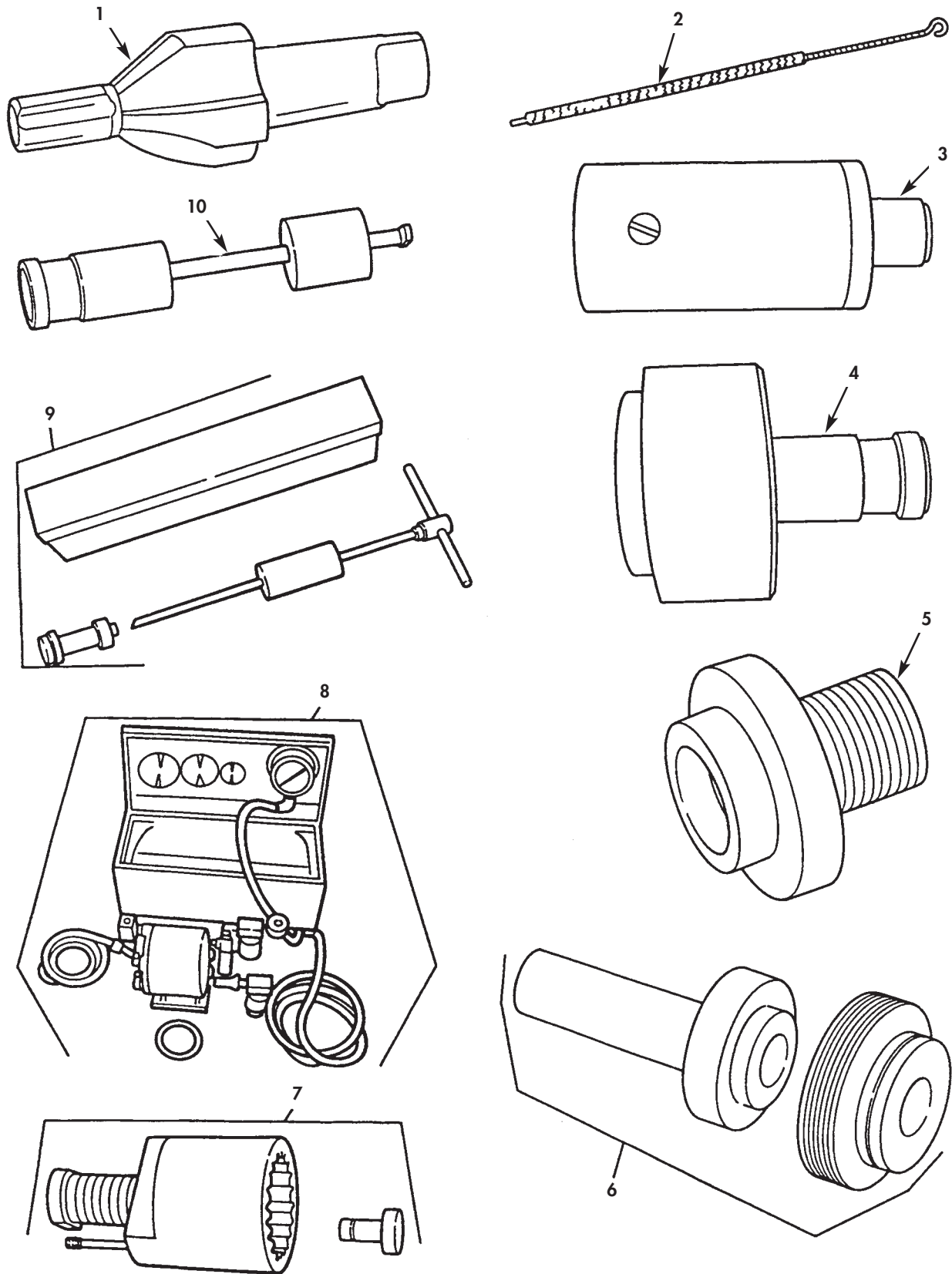


Figure 48. Direct Support Special Tools-2.

(1) ITEM NO	(2) SMR CODE	(3) NSN	(4) CAGEC	(5) PART NUMBER	(6) DESCRIPTION AND USABLE ON CODE(UOC)	(7) QTY
GROUP 2604 SPECIAL TOOLS						
FIG. 48 DIRECT SUPPORT SPECIAL TOOLS-2						
1	PEFZA	4910-00-925-0755	15434	ST824	CUTTER BIT,BORING M INJECTOR SEAT CUTTING.....	
2	PEFZZ	7920-00-168-3244	0B8S3	ST-876	BRUSH,FUEL PASSAGE FUEL PASSAGE CLEANING.....	
3	PEFAA	4910-00-150-5843	15434	ST-1122	DRIVER,VALVE,INSERT VALVE SEAT INSERT STAKING TOOL.....	
4	PEFZZ	4910-00-150-5844	15434	ST-1124	DRIVER,ASSEMBLY,INS VALVE SEAT INSERT STAKING TOOL.....	
5	PEFZZ	4910-01-161-2115	15434	ST-1173	MANDREL,SEAL.....	
6	PEFZZ	5120-01-160-8867	0B8S3	ST-1191	INSERTER,SEAL.....	
7	PEFZZ	5120-01-128-2678	0B8S3	3376663	PULLER,COUPLING.....	
8	PEFZZ	4910-01-128-2691	15434	3824277	TESTER,VALVE VAC VALVE VACUUM.....	
9	PEFZZ	5120-01-128-2679	0B8S3	ST-1279	EXTRACTOR,VALVE,SEA VALVE SEAT.....	
10	PEFZZ	5120-00-116-7604	0B8S3	3823024	PULLER,INJECTOR.....	

END OF FIGURE

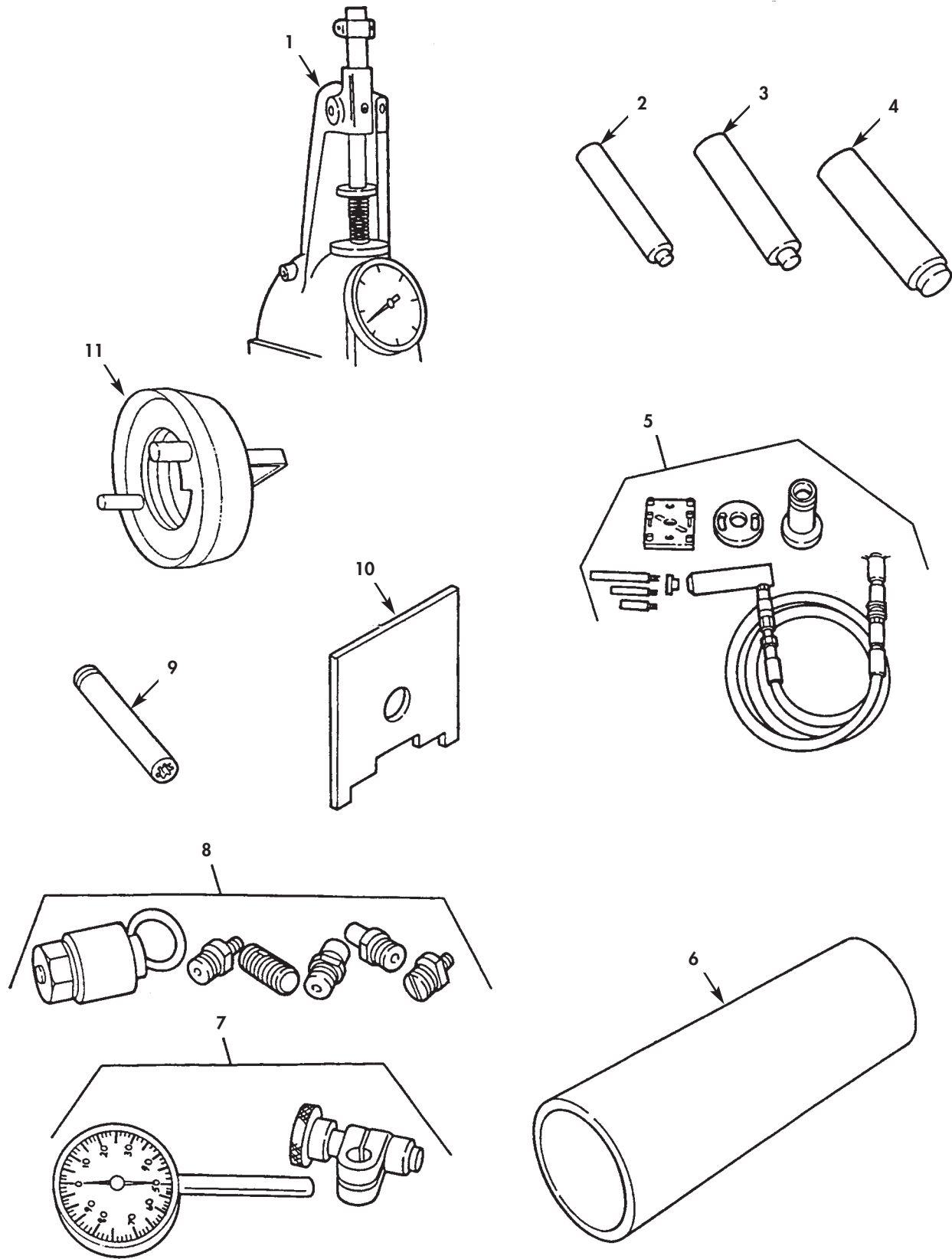


Figure 49. Direct Support Special Tools-3.

(1) ITEM NO	(2) SMR CODE	(3) NSN	(4) CAGEC	(5) PART NUMBER	(6) DESCRIPTION AND USABLE ON CODE(UOC)	(7) QTY
GROUP 2604 SPECIAL TOOLS						
FIG. 49 DIRECT SUPPORT SPECIAL TOOLS-3						
1	PEFZZ	4910-01-142-4929	15434	3375182	TESTER VALVE SPRING.....	
2	PEFZZ	4910-01-143-2023	15434	3375192	EXPANSION PLUG DRIV 1 1/4 INCH PLUG	
3	PEFZZ	4910-01-143-3337	15434	3376816	EXPANSION PLUG DRIV EXPANSION PLUG, 1 INCH PLUG.....	
4	PEFZZ	4910-01-143-3336	15434	3376815	EXPANSION PLUG DRIV EXPANSION PLUG, 3/4 INCH PLUG.....	
5	PEFZZ	5120-01-155-3795	15434	3375257	PULLER,WATER PUMP I.....	
6	PEFZZ	5120-01-128-2675	15434	3375448	DRIVER,SEAL,WP.....	
7	PEFZZ	5210-01-157-2291	0B8S3	3376050	INDICATOR,DIAL.....	
8	PEFZZ	5120-01-156-4183	15434	3376326	PULLER,MECHANICAL.....	
9	PEFZZ		55719	SINL-200	SOCKET,SOCKET WRENC 5/8 INCH X 1/2 DRIVE.....	
10	PEFZZ	5120-01-163-1349	75078	011494	SOCKET,SOCKET WRENC SOLENOID VALVE.	
11	PEFZZ	4910-01-165-4541	15434	3375151	EXPANDER,OIL SEAL.....	

END OF FIGURE

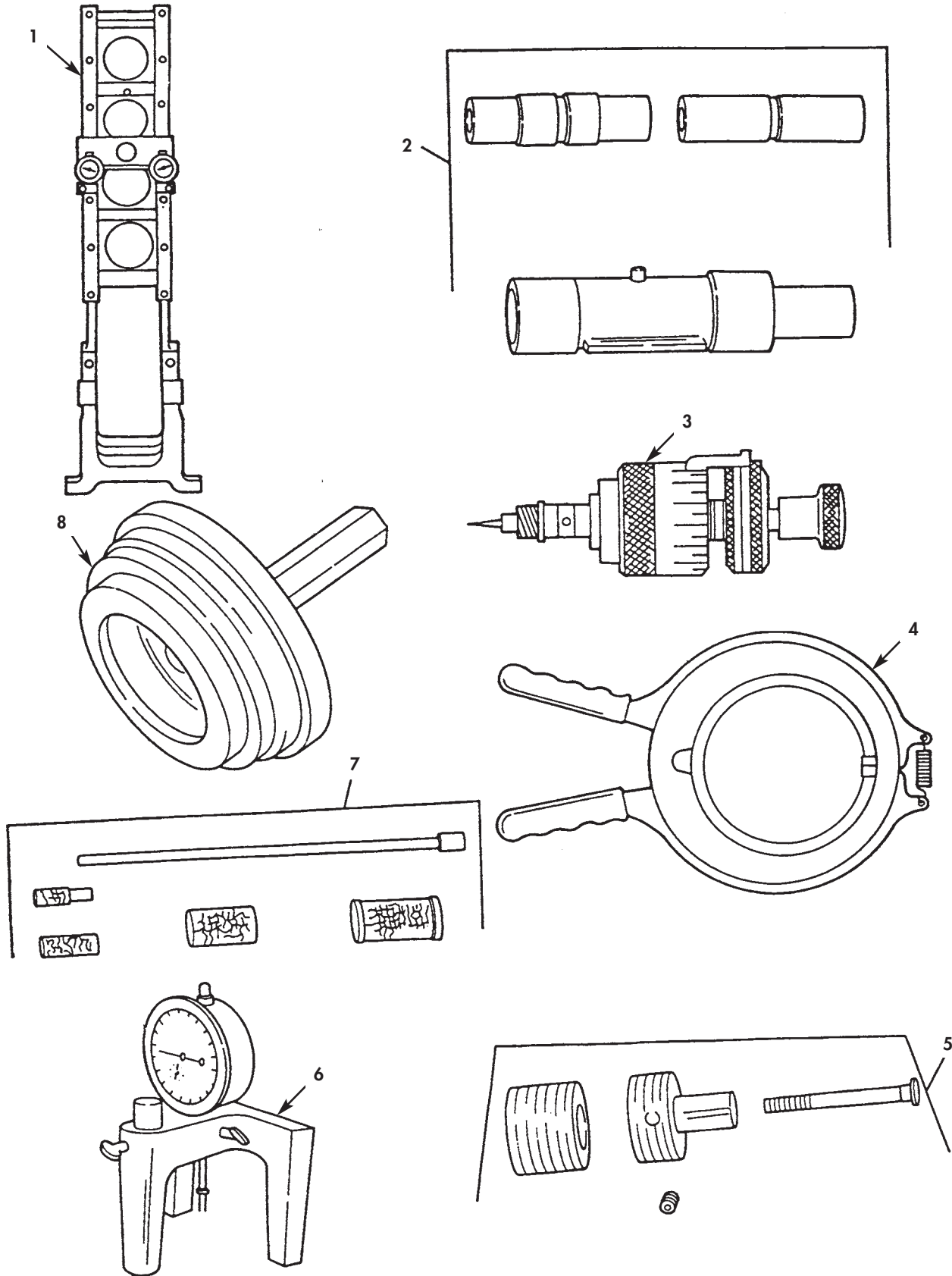


Figure 50. General Support Special Tools-1.

(1) ITEM NO	(2) SMR CODE	(3) NSN	(4) CAGEC	(5) PART NUMBER	(6) DESCRIPTION AND USABLE ON CODE(UOC)	(7) QTY
GROUP 2604 SPECIAL TOOLS						
FIG. 50 GENERAL SUPPORT SPECIAL TOOLS-1						
1	PEHZZ	4910-00-977-7507	15434	ST-561	FIXTURE ASSEMBLY,CH CONNECTING ROD CHECKING.....	
2	PEHZZ	4910-01-146-7130	15434	ST-563	MANDREL.....	
3	PEHZZ	5120-00-999-1503	0B8S3	3376135	BURNISHER,INJECTOR.....	
4	PEHZZ	5120-00-150-7486	0B8S3	3823871	EXPANDER,PISTON RIN PISTON RING....	
5	PEHZZ	4910-01-141-8388	15434	ST-1241	PLUNGER PROTUSION PLUNGER PROTRUSION CHECKING.....	
6	PEHZZ	4910-00-150-5819	15434	ST-1089	EXTENSION,INJECTOR.....	
7	PEHZZ	4910-00-150-5848	15434	ST-1134	EXTRACTOR,VALVE PIN DOWEL PIN.....	
8	PEHZZ	5120-00-999-1206	80244	999-1206	DRIVER,CYLINDER LIN.....	
END OF FIGURE						

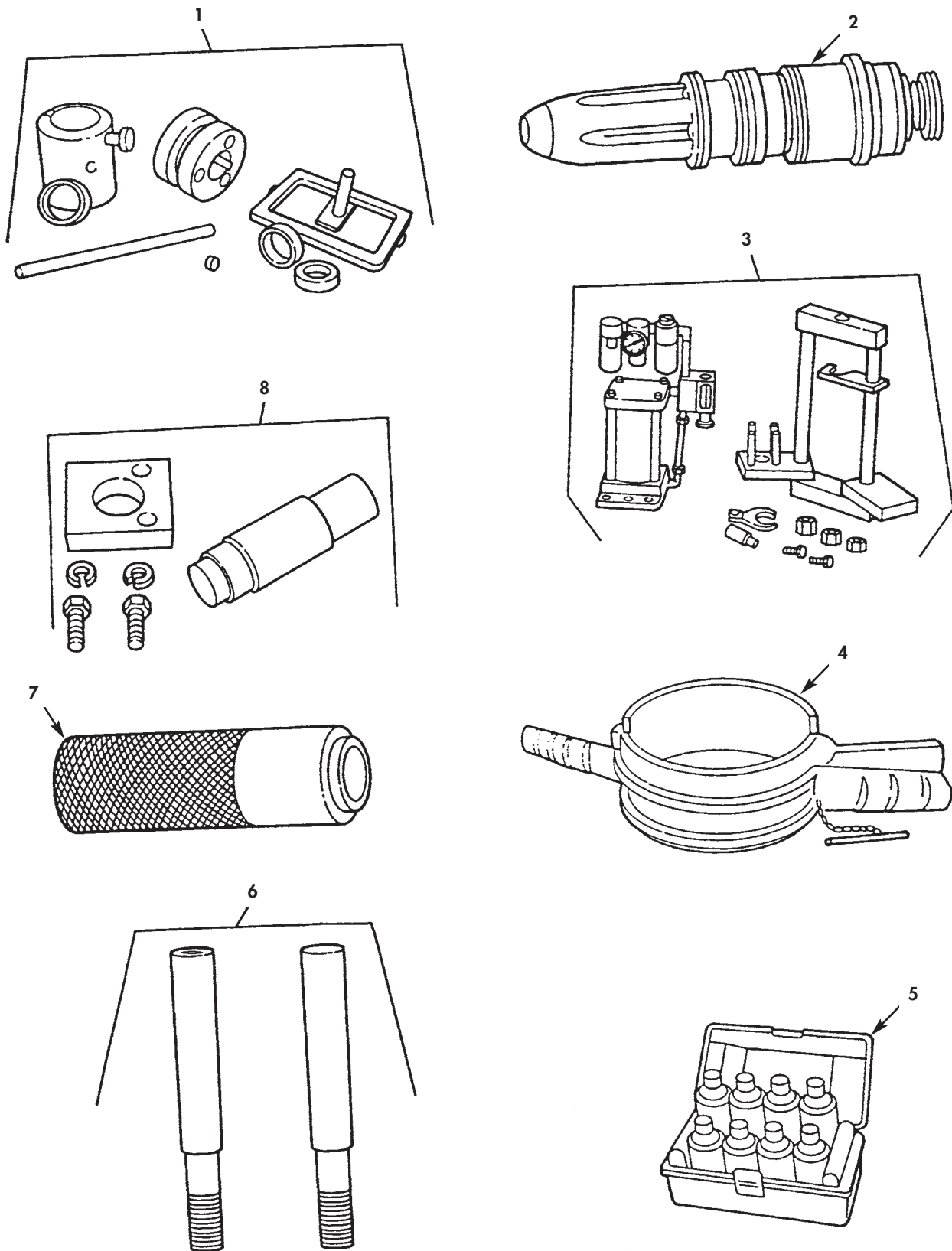


Figure 51. General Support Special Tools-2.

(1) ITEM NO	(2) SMR CODE	(3) NSN	(4) CAGEC	(5) PART NUMBER	(6) DESCRIPTION AND USABLE ON CODE(UOC)	(7) QTY
GROUP 2604 SPECIAL TOOLS						
FIG. 51 GENERAL SUPPORT SPECIAL TOOLS-2						
1	PEHZZ	4910-01-147-7896	15434	ST-1261	CONVERSION KIT,INJE.....	
2	PEHZZ	4910-01-154-6406	15434	ST-1262	MASTER INJECTOR MASTER "K".....	
3	PEHZZ	4910-01-082-1346	15434	ST-1298	STAND ASSEMBLY,INJE.....	
4	PEHZZ	5120-01-128-2758	15434	3375162	COMPRESSOR,PISTON R PISTON RING....	
5	PEHZZ	6635-01-329-2210	15434	3375432	KIT,CRACK DETECTION	
6	PEHZZ	4910-01-165-6016	15434	3375601	GUIDE PIN,SPECIAL,C CONNECTING ROD GUIDE.....	
7	PEHZZ	4910-01-143-2034	15434	3375959	VALVE DRIVER PRESS PRESSURIZING VALVE.....	
8	PEHZZ	4910-01-152-2743	15434	3376011	FIXTURE,VALVE INSTA AFC PRESSURE VALVE.....	
END OF FIGURE						

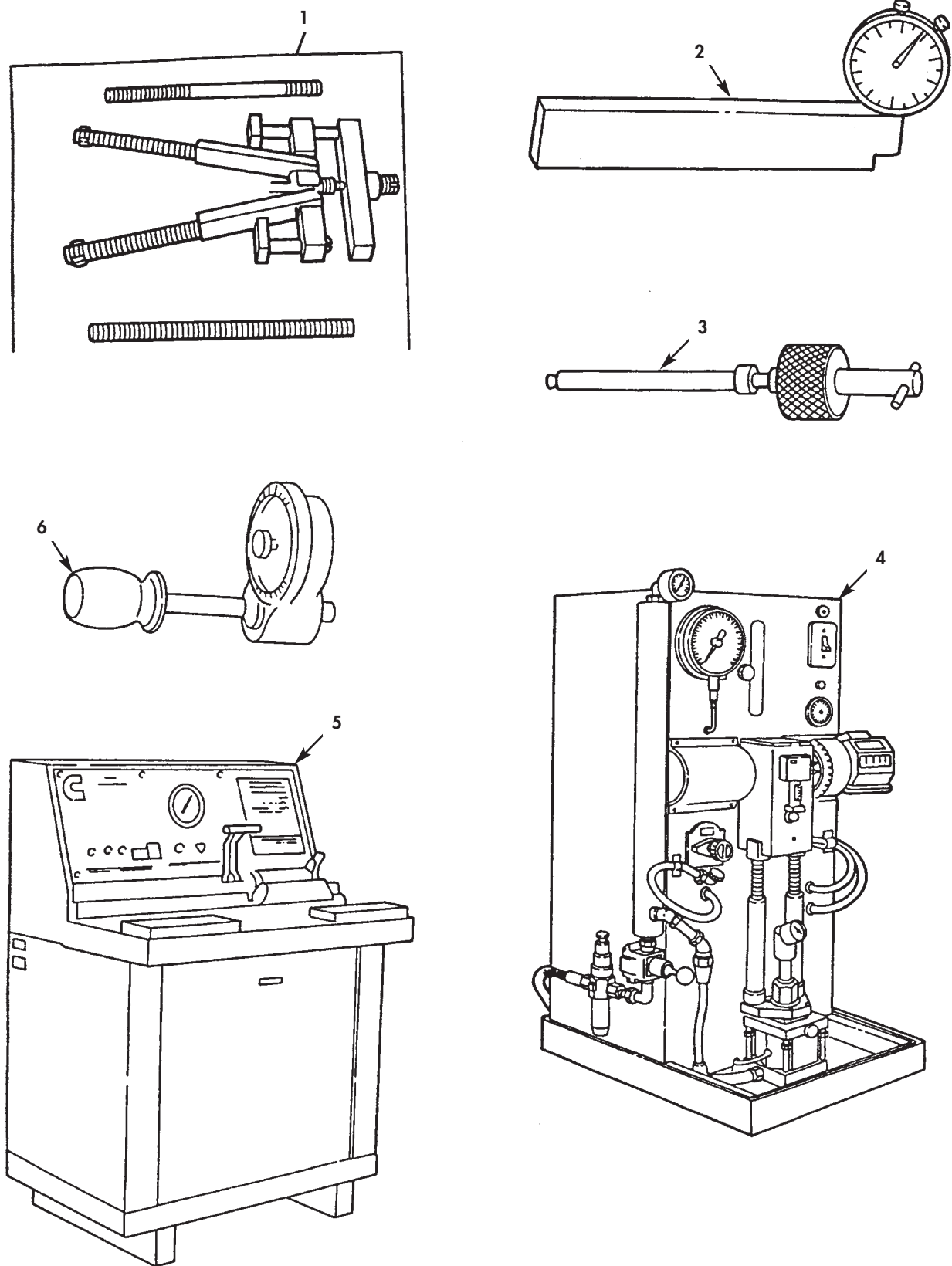


Figure 52. General Support Special Tools-3.

(1) ITEM NO	(2) SMR CODE	(3) NSN	(4) CAGEC	(5) PART NUMBER	(6) DESCRIPTION AND USABLE ON CODE(UOC)	(7) QTY
GROUP 2604 SPECIAL TOOLS						
FIG. 52 GENERAL SUPPORT SPECIAL TOOLS-3						
1	PEHZZ	5120-01-143-2032	0B8S3	3376015	PULLER,MECHANICAL CYLINDER LINER, UNIVERSAL.....	
2	PEHZZ	5210-01-157-3091	0B8S3	3823495	GAGE,DEPTH,DIAL IND.....	
3	PEHZZ	5120-01-128-2688	15434	3375599	PULLER,AFC BARREL.....	
4	PEHZZ	5120-01-029-6861	15434	3375375	INJECTOR,LEAKAGE DE INJECTOR LEAKAGE.....	
5	PEHHH	4910-01-128-9810	05083	MODEL CD3	CALIBRATOR,INJECTOR INJECTOR TEST..	
6	PEFZZ	4910-01-097-6929	15434	3375232	WRENCH TORQUE.....	
END OF FIGURE						

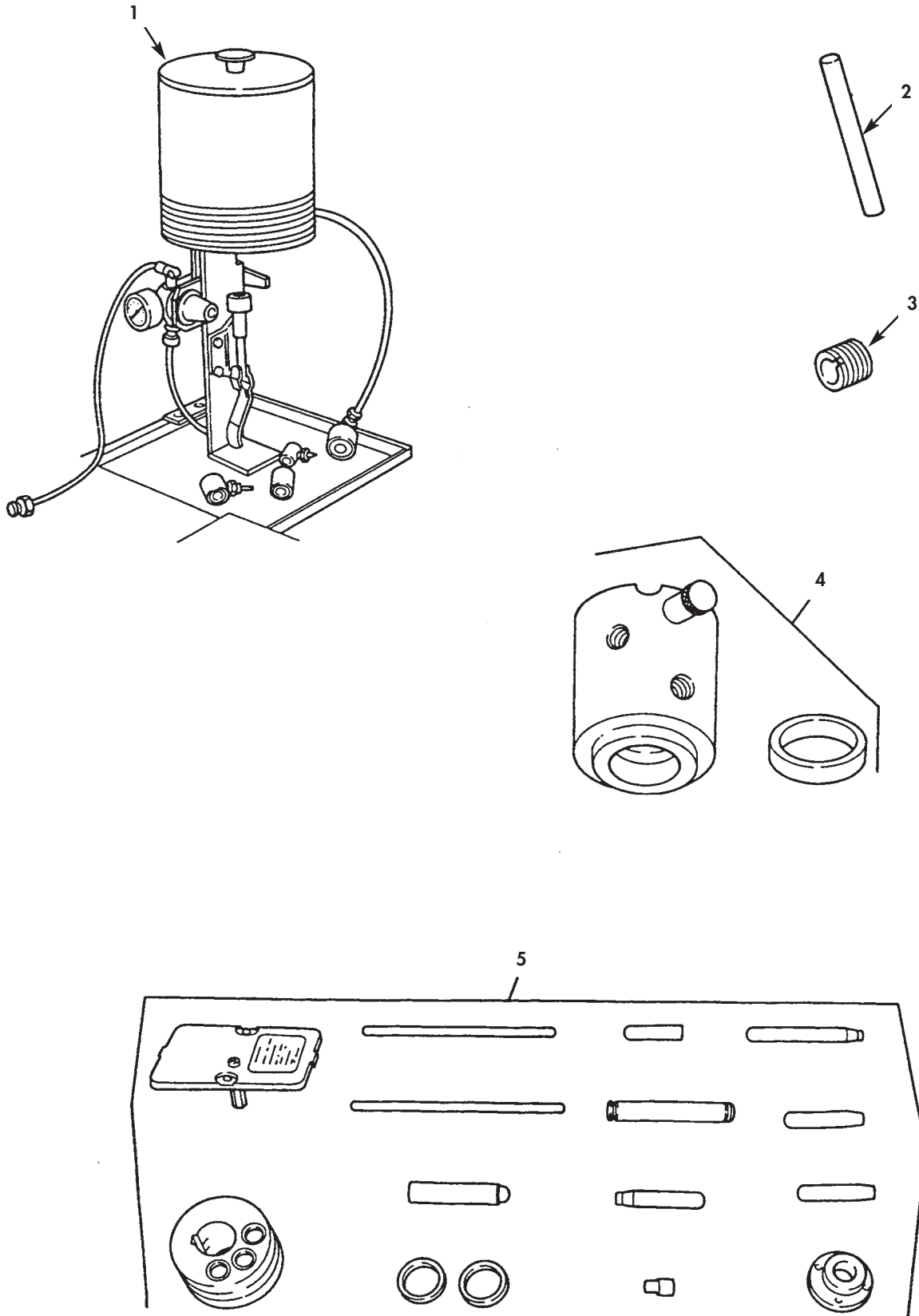


Figure 53. General Support Special Tools-4.

(1) ITEM NO	(2) SMR CODE	(3) NSN	(4) CAGEC	(5) PART NUMBER	(6) DESCRIPTION AND USABLE ON CODE(UOC)	(7) QTY
GROUP 2604 SPECIAL TOOLS						
FIG. 53 GENERAL SUPPORT SPECIAL TOOLS-4						
1	PEHZZ	3465-00-999-1501	15434	3376350	FIXTURE,HOLD-DOWN INJECTOR CUP SPRAY.....	
2	PEHZZ	4910-01-175-5215	15434	ST790-362	LINK,FUEL INJECTOR.....	
3	PEHZZ	4730-01-174-5944	15434	ST790-363	ORIFICE,FUEL INJECT.....	
4	XDHZZ		15434	ST-1254	INJECTOR,ADAPTER,PO.....	
5	PFHZZ	5180-01-177-4415	33287	J 33113	KIT,K-CAM.....	
END OF FIGURE						

**DIRECT SUPPORT AND GENERAL SUPPORT
MAINTENANCE MANUAL
INCLUDING REPAIR PARTS AND SPECIAL TOOLS LIST (RPSTL)**

FOR

M915, M915A1, M915A4, M916, M920 VEHICLES

NSN 2815-01-082-8125	P/N NTC400-3652-02	CUMMINS NTC-400 BIG CAM I DIESEL ENGINE W/CONTAINER
NSN 2815-01-142-2745	P/N 11669835	CUMMINS NTC-400 BIG CAM III DIESEL ENGINE W/CONTAINER

NATIONAL STOCK NUMBER (NSN) INDEX

CROSS REFERENCE INDEXES

NATIONAL STOCK NUMBER INDEX

STOCK NUMBER	FIGURE NO	ITEM NO	STOCK NUMBER	FIGURE NO	ITEM NO
2520-01-085-6128	18	26	2815-01-127-3598	3	10
2520-01-090-4473	11	11	2815-01-133-2445	12	2
2520-01-497-7027	28	21	2815-01-141-0845	5	19
2530-00-827-5934	20	56	2815-01-141-0919	12	2
2530-01-130-2339	20	37	2815-01-141-3261	18	2
2590-00-590-7378	9	1	2815-01-141-5299	13	1
2805-00-293-9699	3	2	2815-01-141-9370	2	6
2815-00-005-7431	8	6	2815-01-142-1732	9	4
2815-00-011-7786	2	1	2815-01-142-2745	1	9
	2	2	2815-01-145-9401	16	23
2815-00-085-7434	3	10	2815-01-145-9402	18	23
2815-00-132-0240	3	10	2815-01-146-0102	5	5
2815-00-195-5894	8	12	2815-01-146-0112	15	3
2815-00-195-5897	8	16	2815-01-146-1024	9	5
2815-00-362-2042	47	1	2815-01-146-1041	7	6
2815-00-369-7846	20	23	2815-01-146-1049	7	5
2815-00-406-6737	26	24	2815-01-146-1103	15	1
2815-00-406-8936	13	45	2815-01-146-1997	18	19
2815-00-480-4347	6	7	2815-01-146-3159	15	2
2815-00-484-8359	2	25	2815-01-146-4164	3	26
2815-00-505-5119	7	24	2815-01-146-5925	4	2
2815-00-603-1381	6	5	2815-01-146-7039	7	14
2815-00-705-2856	13	14	2815-01-152-9219	KIT	11
2815-00-772-9434	16	8	2815-01-159-0872	16	1
2815-00-791-1453	11	22	2815-01-159-1737	9	3
2815-00-815-0355	36	11	2815-01-159-1789	3	16
	36	21	2815-01-160-5820	5	19
2815-00-828-7013	13	44	2815-01-164-6103	9	3
2815-00-829-5227	15	6	2815-01-165-0765	KIT	6
2815-00-851-7637	8	20	2815-01-166-3415	7	11
2815-00-913-2074	KIT	2	2815-01-168-3742	KIT	8
2815-00-920-2073	15	3	2815-01-210-6947	8	30
2815-00-920-8356	15	1	2815-01-241-4719	11	31
2815-00-962-5623	3	12	2815-01-241-6580	6	2
2815-00-994-4427	6	1	2815-01-241-6581	6	3
2815-00-994-4429	6	4	2815-01-291-5753	25	1
2815-01-048-6702	7	18	2815-01-303-4224	4	7
2815-01-077-4463	15	2	2815-01-305-8530	7	16
2815-01-079-1632	4	13	2815-01-354-2702	3	11
2815-01-079-3290	20	19	2815-01-438-1517	1	1
2815-01-079-3380	7	5	2815-01-490-0416	3	15
2815-01-079-9146	16	18	2815-01-497-6028	28	29
2815-01-083-2123	34	3	2815-01-497-6029	28	19
2815-01-085-1881	5	11	2835-01-086-1447	27	18
2815-01-085-2569	8	1	2835-01-497-7320	28	16
2815-01-085-2573	13	1	2910-00-085-7436	29	7
2815-01-085-2574	18	1	2910-00-132-0769	30	51
2815-01-085-2615	7	7	2910-00-304-3427	31	17
2815-01-085-2618	3	15	2910-00-410-2268	33	2
2815-01-085-3733	3	19	2910-00-432-1945	33	4
2815-01-085-8282	3	1	2910-00-646-9727	32	2
2815-01-086-4508	6	8	2910-00-790-8736	24	34
2815-01-087-4740	32	1	2910-00-803-2631	30	48
2815-01-088-7328	18	14	2910-00-858-3522	30	37
2815-01-096-9198	8	2	2910-00-928-3505	3	21
2815-01-098-6755	18	18	2910-01-065-3979	23	6
2815-01-105-8768	2	6	2910-01-070-9712	24	62
2815-01-124-0232	6	10	2910-01-076-8632	21	10
	17	23	2910-01-080-3149	24	49
2815-01-127-1060	3	10	2910-01-080-5570	24	67
2815-01-127-3597	3	10	2910-01-084-0243	32	4

CROSS REFERENCE INDEXES

NATIONAL STOCK NUMBER INDEX

STOCK NUMBER	FIGURE NO	ITEM NO	STOCK NUMBER	FIGURE NO	ITEM NO
2910-01-085-2570	31	1		13	18
2910-01-086-3974	21	13	2940-01-146-5846	10	25
2910-01-086-3983	24	35	2940-01-184-1877	KIT	13
2910-01-086-7715	30	7	2940-01-227-7445	35	10
2910-01-086-9757	7	22	2950-01-141-0844	26	22
2910-01-090-9346	30	34	2950-01-145-6822	27	18
2910-01-091-7507	24	47	2950-01-503-5597	28	11
2910-01-096-9200	25	3	2990-00-477-6159	27	16
2910-01-098-5118	24	39	2990-00-772-1778	24	63
2910-01-112-5797	32	15	2990-01-085-1622	27	10
2910-01-112-7712	21	4	2990-01-085-4768	27	8
2910-01-126-9053	24	15	2990-01-120-2883	4	2
2910-01-136-3331	24	67	2990-01-146-1102	26	4
2910-01-141-4028	24	42	2990-01-146-3911	27	19
2910-01-141-4029	24	7	2990-01-155-7284	26	22
2910-01-141-4337	30	18	2990-01-172-3005	26	22
2910-01-141-4967	24	5	2990-01-236-2774	26	4
2910-01-141-9372	23	6	2990-01-271-0316	KIT	7
2910-01-142-4953	24	22	3010-00-447-9799	23	9
2910-01-142-7455	24	12		30	27
2910-01-145-9403	21	4	3010-01-079-3461	20	4
2910-01-146-0048	3	7	3010-01-080-1529	30	24
2910-01-146-0093	22	21	3010-01-085-2732	17	26
2910-01-146-1084	24	35		20	35
2910-01-146-1099	31	17	3010-01-088-5727	30	13
2910-01-146-1998	21	13	3010-01-146-0113	13	30
2910-01-146-1999	30	1	3020-00-160-9092	17	20
2910-01-146-2000	33	11	3020-00-528-5053	5	12
2910-01-146-7955	2	37	3020-00-702-3882	25	11
2910-01-147-9913	24	40	3020-01-070-9003	30	14
2930-00-401-9531	17	18	3020-01-077-2229	4	16
2930-00-928-3595	34	1	3020-01-077-4411	4	12
2930-01-065-7113	11	30	3020-01-079-4206	36	26
2930-01-084-6011	34	11	3020-01-084-7007	44	6
2930-01-087-8749	34	28	3020-01-084-9640	13	19
2930-01-097-6755	17	2	3020-01-085-0761	44	5
2930-01-141-0918	10	1	3020-01-085-3779	13	24
2930-01-141-9277	14	34	3020-01-086-3417	36	13
2930-01-145-9537	10	4	3020-01-086-4158	30	23
2930-01-145-9538	10	8	3020-01-086-8269	44	7
2930-01-146-1081	10	28	3020-01-086-8780	30	12
2930-01-146-1083	14	4	3020-01-145-8568	7	2
2930-01-146-1085	34	9	3020-01-146-0107	4	16
2930-01-146-1996	14	9	3020-01-146-0108	13	8
2930-01-146-3033	34	18	3020-01-146-0109	13	19
2930-01-146-3912	36	1	3020-01-146-3163	17	17
2930-01-146-4212	34	3	3020-01-146-3773	17	15
2930-01-150-7596	34	11	3020-01-241-6905	36	13
2930-01-165-4581	11	27	3030-01-065-9404	36	28
2930-01-231-1661	11	13	3040-00-388-3126	7	13
2930-01-262-5153	KIT	15	3040-00-567-4354	25	18
2930-01-262-5175	36	19	3040-00-933-3012	25	12
2930-01-287-9733	KIT	14	3040-01-070-9004	30	21
2940-01-019-4513	10	34	3040-01-077-4976	21	2
	11	43	3040-01-079-1799	8	29
2940-01-065-7076	11	47	3040-01-079-3468	36	25
2940-01-145-9398	10	12	3040-01-079-3469	13	23
2940-01-145-9399	10	13	3040-01-085-2616	29	13
2940-01-145-9400	10	14	3040-01-085-2871	30	8
2940-01-145-9455	10	35	3040-01-086-1448	27	19
2940-01-146-1995	11	34	3040-01-086-1449	24	51

CROSS REFERENCE INDEXES

NATIONAL STOCK NUMBER INDEX

STOCK NUMBER	FIGURE NO	ITEM NO	STOCK NUMBER	FIGURE NO	ITEM NO
3040-01-086-1651	24	22	3120-01-214-7779	4	8
3040-01-129-4302	17	30	3120-01-215-9157	25	17
3040-01-145-9637	13	20	3130-00-408-9041	2	24
3040-01-146-0028	5	3	3130-01-146-1150	2	25
3040-01-146-5935	13	25	3130-01-146-1228	2	23
3040-01-151-9348	30	8	3130-01-146-4504	2	24
3040-01-154-9787	33	7	3130-01-294-1400	27	14
3040-01-241-4696	24	54	3441-00-922-6699	37	21
3040-01-287-9736	36	7	3460-00-999-1173	47	8
3110-00-144-8828	36	8	3460-00-999-1210	39	13
	36	24	3465-00-999-1501	53	1
3110-00-516-5289	30	16	3805-00-955-5320	20	45
3110-01-079-8190	24	57	4140-01-085-2607	27	3
3120-00-353-9164	33	6	4140-01-146-1035	27	3
3120-00-566-0480	13	7	4310-00-903-7174	20	22
3120-00-589-3537	8	5	4310-01-079-3319	20	25
	8	15	4310-01-079-3383	20	29
	8	23	4310-01-079-5245	20	17
	8	19	4310-01-084-7148	20	48
3120-00-627-6697	13	4	4310-01-092-9815	17	11
	13	26	4310-01-092-9816	17	22
3120-00-659-7808	7	17	4310-01-141-0879	20	8
3120-00-682-7706	27	13	4310-01-146-1097	20	14
3120-00-791-1440	7	23	4310-01-146-4155	20	51
3120-00-792-9834	17	32	4310-01-146-5921	20	12
3120-00-810-6032	24	41	4310-01-271-5103	20	20
3120-00-877-2213	16	2	4320-01-079-3454	36	2
3120-00-904-9595	30	17	4320-01-098-5115	24	56
3120-01-016-4883	20	26	4330-00-274-4712	35	9
3120-01-079-5208	8	9	4330-01-020-3666	35	10
3120-01-079-5451	7	27	4330-01-146-1082	10	24
3120-01-079-6527	15	10	4420-01-318-0852	14	32
	35	3	4710-01-079-3198	34	15
3120-01-079-6823	2	30	4710-01-079-3492	19	13
3120-01-079-8194	7	3		19	17
3120-01-080-3275	24	36	4710-01-079-3493	22	11
3120-01-083-6411	36	14	4710-01-085-6132	14	35
3120-01-085-0762	44	2	4710-01-085-6134	22	16
3120-01-087-2539	30	11	4710-01-085-9348	22	9
3120-01-087-3004	6	12	4710-01-085-9349	22	18
3120-01-103-8752	39	8	4710-01-092-0109	12	43
3120-01-129-7659	20	36	4710-01-095-8683	19	13
3120-01-132-9339	4	6	4710-01-142-1667	12	24
3120-01-143-9547	4	6	4710-01-146-0049	12	15
3120-01-144-7368	17	28	4710-01-146-0050	13	33
3120-01-144-8882	4	6	4710-01-146-1052	12	6
3120-01-145-9132	4	6	4710-01-146-1053	14	35
3120-01-146-7196	20	24	4710-01-146-1054	34	15
3120-01-147-5275	17	21	4710-01-146-1113	22	16
3120-01-147-8118	5	6	4710-01-146-1114	22	11
3120-01-149-5414	13	7	4710-01-146-1115	22	10
3120-01-155-2531	KIT	9	4710-01-146-1116	22	14
3120-01-155-4442	6	12	4710-01-146-3085	19	4
3120-01-155-8707	6	12	4710-01-146-3086	11	37
3120-01-157-3316	6	12		34	25
3120-01-160-7482	24	64	4710-01-146-3167	26	16
3120-01-185-8586	25	19	4710-01-146-3168	19	17
3120-01-193-7083	4	6	4710-01-146-3169	22	18
3120-01-208-8102	2	30	4710-01-146-3779	22	9
3120-01-208-8103	2	30	4710-01-146-4083	14	14
3120-01-212-4472	7	21	4710-01-158-7507	10	46

CROSS REFERENCE INDEXES

NATIONAL STOCK NUMBER INDEX

STOCK NUMBER	FIGURE NO	ITEM NO	STOCK NUMBER	FIGURE NO	ITEM NO
	26	20		26	17
4710-01-181-1956	11	6	4730-00-555-8292	24	30
4710-01-209-6742	16	3	4730-00-801-8186	2	26
4720-00-187-4102	35	13	4730-00-900-3296	22	31
	BULK	3	4730-00-908-3195	35	6
4720-00-278-4890	12	14	4730-00-909-8627	34	14
4720-00-541-4243	BULK	1	4730-00-954-1281	2	10
4720-00-918-9634	19	2	4730-00-954-9510	35	12
4720-01-006-8626	26	18	4730-00-964-7548	20	30
4720-01-070-8149	26	6	4730-01-077-2016	21	17
4720-01-079-3285	13	33	4730-01-078-6364	24	58
4720-01-085-2571	11	5	4730-01-079-3273	19	1
4720-01-085-6129	34	23	4730-01-079-3274	26	19
4720-01-085-6131	14	11	4730-01-085-4156	19	9
4720-01-085-6293	26	10		34	12
4720-01-114-7728	BULK	2	4730-01-085-7328	15	12
4720-01-146-1071	26	10	4730-01-106-4700	22	19
4720-01-146-4126	32	9		31	19
4720-01-152-0156	13	50	4730-01-109-8501	22	17
4730-00-010-3867	12	8	4730-01-124-0293	8	27
	16	13	4730-01-124-3762	24	27
	36	5		31	15
4730-00-011-3175	29	14	4730-01-127-6104	26	9
4730-00-018-9566	2	27	4730-01-131-4884	22	12
	3	24	4730-01-142-8524	13	51
	5	23		22	20
	11	35	4730-01-146-1059	32	6
	14	40	4730-01-146-1060	34	12
	16	10	4730-01-146-1064	14	18
	17	31	4730-01-146-1065	14	2
	19	10	4730-01-146-3040	22	22
	36	4	4730-01-146-3109	14	16
4730-00-042-8988	10	6	4730-01-146-3111	12	13
	11	21	4730-01-146-3631	26	14
	16	13	4730-01-146-3633	22	15
	24	30	4730-01-146-4016	35	6
4730-00-044-4715	12	10	4730-01-146-7047	26	15
4730-00-057-5555	10	7	4730-01-161-5115	2	16
4730-00-081-9618	2	9		13	5
4730-00-138-3906	19	15		36	5
4730-00-202-8470	13	42	4730-01-163-7192	11	4
4730-00-203-0549	2	14	4730-01-165-0749	35	5
4730-00-221-2139	2	19		35	8
	34	30	4730-01-174-5944	53	3
4730-00-254-6227	11	50	4730-01-214-7081	2	8
4730-00-277-8269	20	58		5	18
4730-00-278-2973	25	9		13	5
4730-00-278-4822	32	17	4730-01-241-7258	11	2
4730-00-278-9200	22	23	4730-01-309-3321	11	25
4730-00-338-6839	12	48	4730-99-214-1783	12	8
4730-00-365-2690	10	44	4810-01-187-4925	29	4
	19	12	4810-01-225-6010	18	4
	26	25	4820-00-276-9041	10	36
4730-00-374-4282	19	16		11	12
4730-00-404-2906	34	26	4820-00-445-0610	20	40
4730-00-404-2909	2	33	4820-00-829-5600	29	17
4730-00-444-1710	3	25	4820-00-909-4174	20	42
	22	13	4820-00-909-4175	20	46
4730-00-477-4160	26	5	4820-01-045-6080	35	4
4730-00-555-8263	14	1	4820-01-070-9710	21	12
	19	3	4820-01-079-3241	24	4

CROSS REFERENCE INDEXES

NATIONAL STOCK NUMBER INDEX

STOCK NUMBER	FIGURE NO	ITEM NO	STOCK NUMBER	FIGURE NO	ITEM NO
4820-01-079-3320	24	10	4910-01-097-6935	45	26
4820-01-089-3939	18	20	4910-01-097-6936	43	13
4820-01-145-9457	13	17	4910-01-097-6937	43	14
4820-01-146-1048	29	12	4910-01-097-6938	43	15
4820-01-146-4593	18	20	4910-01-097-6939	41	12
4820-01-158-0555	KIT	5	4910-01-097-6940	41	9
4820-01-164-7002	25	15	4910-01-097-6941	41	10
4820-01-210-3573	10	16	4910-01-097-6944	45	24
4820-01-210-9571	34	4	4910-01-097-6945	46	1
4820-01-227-7141	35	4	4910-01-097-6955	37	23
4820-01-242-2579	25	10	4910-01-097-6956	37	26
4910-00-150-5797	39	28	4910-01-097-6957	37	17
4910-00-150-5801	41	2	4910-01-097-6958	37	19
4910-00-150-5805	41	24	4910-01-097-6960	40	9
4910-00-150-5819	50	6	4910-01-097-6962	40	8
4910-00-150-5843	48	3	4910-01-097-6963	40	11
4910-00-150-5844	48	4	4910-01-097-6964	40	4
4910-00-150-5848	50	7	4910-01-097-6965	40	10
4910-00-150-5858	37	14	4910-01-097-6966	40	14
4910-00-345-3708	47	2	4910-01-097-6968	40	12
4910-00-925-0755	48	1	4910-01-097-6969	39	5
4910-00-977-7507	50	1	4910-01-097-6970	39	2
4910-00-981-3105	37	16	4910-01-097-6971	39	12
4910-00-999-1208	47	9	4910-01-097-6972	38	16
4910-00-999-1506	38	2	4910-01-097-6976	40	15
4910-01-074-0020	46	8	4910-01-097-6977	39	19
4910-01-082-1346	51	3	4910-01-097-6979	39	22
4910-01-084-6977	45	12	4910-01-097-6980	39	27
4910-01-084-6978	45	13	4910-01-097-6981	39	26
4910-01-084-6979	45	4	4910-01-097-6982	39	25
4910-01-084-7221	45	10	4910-01-097-6983	39	24
4910-01-084-7222	45	9	4910-01-097-6984	39	21
4910-01-085-0751	45	3	4910-01-097-6985	39	23
4910-01-085-0763	44	4	4910-01-097-6986	39	17
4910-01-085-0765	44	12	4910-01-097-6987	38	3
4910-01-085-0766	44	17	4910-01-097-6988	38	15
4910-01-085-1011	44	1	4910-01-097-6989	37	2
4910-01-085-7824	45	2		38	6
4910-01-085-9211	37	27	4910-01-098-1912	44	8
4910-01-086-8268	44	9	4910-01-098-1914	37	4
4910-01-086-9766	46	2	4910-01-098-1915	41	23
4910-01-088-7904	44	10	4910-01-098-1916	41	22
4910-01-097-6909	44	16	4910-01-098-1917	41	15
4910-01-097-6910	41	17	4910-01-098-1918	41	20
4910-01-097-6911	41	21	4910-01-098-1919	41	18
4910-01-097-6912	41	19	4910-01-098-5088	37	18
4910-01-097-6914	44	14	4910-01-099-1487	37	9
4910-01-097-6915	41	5	4910-01-100-6191	41	16
4910-01-097-6916	43	3	4910-01-105-9165	45	1
4910-01-097-6917	43	4	4910-01-106-0492	43	1
4910-01-097-6919	43	2	4910-01-108-9130	37	12
4910-01-097-6923	45	18	4910-01-112-7509	37	5
4910-01-097-6925	45	19	4910-01-113-1066	37	6
4910-01-097-6926	43	9	4910-01-117-4885	37	10
4910-01-097-6927	43	10	4910-01-118-2878	37	11
4910-01-097-6928	43	11	4910-01-118-3747	41	6
4910-01-097-6929	52	6	4910-01-128-2691	48	8
4910-01-097-6930	38	5	4910-01-128-9810	52	5
4910-01-097-6931	45	27	4910-01-141-8388	50	5
4910-01-097-6933	45	22	4910-01-142-4929	49	1
4910-01-097-6934	45	21	4910-01-143-2023	49	2

CROSS REFERENCE INDEXES

NATIONAL STOCK NUMBER INDEX

STOCK NUMBER	FIGURE NO	ITEM NO	STOCK NUMBER	FIGURE NO	ITEM NO
4910-01-143-2034	51	7		49	8
4910-01-143-3336	49	4	5120-01-160-8863	38	1
4910-01-143-3337	49	3	5120-01-160-8867	48	6
4910-01-146-7130	50	2	5120-01-163-1349	49	10
4910-01-147-7896	51	1	5120-01-164-3265	47	7
4910-01-150-9713	47	5	5133-00-932-2089	37	13
4910-01-152-2743	51	8	5133-01-084-6008	44	13
4910-01-154-6406	51	2	5133-01-084-6009	44	18
4910-01-159-8701	47	6	5180-00-916-1813	40	16
4910-01-161-2115	48	5	5180-01-069-6998	46	KIT
4910-01-165-4541	49	11	5180-01-071-0707	40	KIT
4910-01-165-6016	51	6	5180-01-074-0019	43	12
4910-01-175-5215	53	2	5180-01-102-8418	41	7
4920-00-711-9307	47	4	5180-01-141-9274	43	KIT
4930-01-085-3728	45	5		46	KIT
5110-00-980-7347	40	2	5180-01-177-4415	53	5
5110-00-981-3107	42	3	5210-00-999-1209	37	28
5120-00-065-1031	44	11	5210-01-099-6339	37	22
	46	4	5210-01-157-2291	49	7
5120-00-103-4687	38	8	5210-01-157-3091	52	2
5120-00-104-1795	37	29	5220-00-795-3079	42	5
5120-00-113-5271	39	1	5220-01-168-6878	42	6
5120-00-116-7604	48	10	5305-00-058-6604	36	15
5120-00-150-5810	41	4	5305-00-062-4378	3	17
5120-00-150-7486	50	4	5305-00-063-5043	24	70
5120-00-150-7488	42	1	5305-00-068-0502	26	12
5120-00-150-7492	37	20	5305-00-068-0509	31	2
5120-00-159-8916	40	21	5305-00-068-0511	10	32
5120-00-178-0948	40	3		13	28
5120-00-865-0226	38	11		13	35
5120-00-896-8087	41	3		14	10
5120-00-896-8097	37	3		26	3
5120-00-923-0856	46	7	5305-00-071-2056	20	3
5120-00-981-3108	37	15	5305-00-071-2517	10	40
5120-00-999-1206	50	8	5305-00-091-4006	10	2
5120-00-999-1503	50	3	5305-00-091-4009	5	13
5120-00-999-1504	38	4	5305-00-137-3269	13	28
5120-00-999-1505	41	1	5305-00-138-9848	29	5
5120-01-029-6861	52	4	5305-00-165-8157	11	41
5120-01-072-2952	38	7	5305-00-177-5552	11	18
5120-01-072-2955	45	15	5305-00-207-2715	31	5
5120-01-097-3204	40	19	5305-00-225-8507	20	9
5120-01-097-6932	45	20	5305-00-226-4831	19	5
5120-01-099-6341	39	11	5305-00-230-1939	26	12
5120-01-100-0135	46	6	5305-00-269-3240	5	2
5120-01-106-9173	40	20	5305-00-297-4022	8	24
5120-01-106-9174	40	18	5305-00-339-1415	7	15
5120-01-119-2743	37	8	5305-00-404-1388	10	33
5120-01-120-3681	45	14	5305-00-404-1390	14	30
5120-01-120-3682	39	3	5305-00-411-9340	27	9
5120-01-120-5759	44	15	5305-00-426-4142	13	31
5120-01-120-5760	42	2		30	40
5120-01-122-6014	38	10	5305-00-477-6769	3	20
5120-01-128-2675	49	6	5305-00-493-3959	33	5
5120-01-128-2678	48	7	5305-00-506-5722	30	52
5120-01-128-2679	48	9	5305-00-509-8106	29	1
5120-01-128-2688	52	3	5305-00-543-4372	12	31
5120-01-128-2758	51	4		13	9
5120-01-143-2032	52	1		13	48
5120-01-155-3795	49	5		14	12
5120-01-156-4183	39	18		14	24

CROSS REFERENCE INDEXES

NATIONAL STOCK NUMBER INDEX

STOCK NUMBER	FIGURE NO	ITEM NO	STOCK NUMBER	FIGURE NO	ITEM NO
5305-00-546-6698	2	35	5305-01-113-1179	23	10
	7	10		30	6
	12	22	5305-01-114-6386	5	16
5305-00-638-8920	10	39	5305-01-114-9279	30	26
5305-00-721-3698	25	21	5305-01-118-4285	20	54
5305-00-725-2317	10	26	5305-01-118-8826	9	2
	14	39	5305-01-119-8621	17	29
5305-00-782-9489	10	29	5305-01-126-1128	30	40
5305-00-795-9336	4	14	5305-01-129-4214	13	6
	5	10		19	8
5305-00-795-9345	22	7	5305-01-129-4218	24	2
5305-00-795-9352	13	46	5305-01-129-4384	20	34
5305-00-804-6318	1	7		23	7
	20	28	5305-01-129-4385	24	1
	24	29	5305-01-129-4386	36	29
	26	23	5305-01-129-6901	8	31
5305-00-843-9529	15	7	5305-01-130-6100	4	3
5305-00-942-2196	13	48	5305-01-133-2060	31	11
5305-00-944-8292	12	21	5305-01-135-5344	11	1
	14	20	5305-01-135-5446	24	50
5305-00-947-3437	8	4	5305-01-137-6706	14	24
	8	8	5305-01-144-6204	2	36
	8	14	5305-01-144-6206	18	9
	8	18	5305-01-144-6232	10	19
	8	22	5305-01-144-6233	20	53
5305-01-010-2362	13	9	5305-01-145-0776	17	8
5305-01-028-8869	15	5	5305-01-145-0777	21	3
5305-01-029-1193	22	5		23	7
5305-01-032-2311	12	33	5305-01-145-1113	12	38
5305-01-072-8816	16	22	5305-01-145-8358	12	36
5305-01-072-8818	14	10	5305-01-145-8359	20	31
5305-01-072-8826	24	53	5305-01-145-8379	3	28
5305-01-072-8831	30	19	5305-01-145-8380	5	15
5305-01-079-7028	21	5	5305-01-145-8381	16	7
5305-01-084-4596	44	3	5305-01-145-8382	17	1
5305-01-085-8197	11	9	5305-01-145-8383	17	12
	12	28	5305-01-145-8384	18	13
	34	8	5305-01-146-7285	14	29
5305-01-086-7036	11	42	5305-01-147-1215	14	15
	34	13	5305-01-147-2443	13	46
5305-01-086-7285	21	3	5305-01-147-2444	14	5
5305-01-088-6019	11	15	5305-01-147-2445	14	28
	11	38	5305-01-147-4025	5	24
	33	17	5305-01-147-4033	16	12
	34	29	5305-01-147-4034	20	2
	35	1		23	1
5305-01-091-2498	17	5	5305-01-147-4035	36	31
5305-01-097-6918	43	5	5305-01-147-8726	31	14
5305-01-097-6920	43	7	5305-01-147-8729	14	30
5305-01-097-6921	41	8	5305-01-147-8730	15	5
	43	8	5305-01-147-8731	16	17
5305-01-097-6924	45	16	5305-01-147-8732	23	4
5305-01-098-1913	43	6	5305-01-165-3300	16	14
5305-01-109-9307	24	45	5305-01-165-3892	16	20
5305-01-112-9021	2	11	5305-01-179-2380	2	22
	12	45	5305-01-186-7042	18	9
5305-01-112-9110	30	19	5305-01-203-6444	11	7
	30	35	5305-01-212-5210	12	36
	31	2	5305-01-240-7155	16	12
5305-01-112-9698	5	9	5305-01-319-9287	35	11
5305-01-113-0408	34	19	5305-01-498-0704	28	15

CROSS REFERENCE INDEXES

NATIONAL STOCK NUMBER INDEX

STOCK NUMBER	FIGURE NO	ITEM NO	STOCK NUMBER	FIGURE NO	ITEM NO
5305-01-508-7097	10	20		11	40
5306-00-225-8499	14	37		12	17
5306-00-418-2276	32	19		13	27
5306-00-485-0790	25	7		14	13
5306-01-079-7027	6	11		14	25
5306-01-102-3599	33	18		22	2
5306-01-107-6371	18	27		36	32
5306-01-119-4271	17	24	5310-00-262-2986	29	3
5306-01-119-8870	34	22	5310-00-285-8833	3	27
5306-01-146-9866	16	19	5310-00-356-1447	2	21
5306-01-151-1023	32	14	5310-00-407-9566	12	40
5306-01-204-3297	22	7		19	6
5307-00-922-2626	15	13		20	10
	26	7		30	28
5307-01-109-5972	18	27	5310-00-426-3990	3	18
5307-01-145-8449	18	31	5310-00-451-6643	12	16
5307-01-147-1316	18	29		24	6
5307-01-147-2821	18	30	5310-00-469-3998	5	21
5310-00-005-6052	24	48	5310-00-470-6154	17	6
5310-00-011-6122	20	1	5310-00-484-1718	24	26
	23	2		25	8
5310-00-013-1245	32	21		29	2
5310-00-080-6004	5	7		31	3
	10	27	5310-00-486-2505	14	25
	12	27		22	3
	13	36	5310-00-486-2507	17	25
	14	26	5310-00-507-3259	30	50
5310-00-081-4219	12	41	5310-00-521-8595	13	40
	34	20		14	23
5310-00-081-8500	4	15		22	1
	5	14	5310-00-562-6552	33	8
5310-00-081-9292	17	27	5310-00-562-6557	13	36
5310-00-082-1882	2	21	5310-00-562-6558	12	4
5310-00-082-1888	29	10		19	7
5310-00-086-7859	24	60		20	11
	30	32	5310-00-562-6560	10	42
5310-00-134-4168	5	17		22	3
5310-00-134-4169	14	38		24	3
5310-00-134-4171	5	8		27	6
	11	46	5310-00-584-5272	1	3
5310-00-141-1795	25	16		5	20
	25	20		11	8
	30	36	5310-00-637-9541	10	38
	31	13		12	46
	33	14		13	32
5310-00-159-6209	10	41		22	25
	14	13		32	20
	22	2	5310-00-650-0187	20	7
	31	12	5310-00-680-6874	27	5
	33	13	5310-00-684-3463	26	2
5310-00-197-5304	2	29	5310-00-732-0560	8	3
5310-00-209-0965	12	34		8	7
	13	27		8	13
	16	21		8	17
	20	33		8	21
	30	3	5310-00-763-8920	36	17
5310-00-261-7340	2	34	5310-00-809-3078	30	25
	7	9	5310-00-809-4085	12	35
	10	3	5310-00-820-6653	11	45
	10	31		12	17
	11	17		14	21

CROSS REFERENCE INDEXES

NATIONAL STOCK NUMBER INDEX

STOCK NUMBER	FIGURE NO	ITEM NO	STOCK NUMBER	FIGURE NO	ITEM NO
5310-00-823-8803	12	18	5315-00-866-5015	3	8
5310-00-828-4827	12	3	5315-00-907-0711	24	66
5310-00-887-8325	15	8	5315-01-058-4551	4	9
5310-00-922-2017	29	6	5315-01-079-6506	21	15
5310-00-971-7989	24	43	5315-01-079-6740	4	17
	33	9	5315-01-087-0534	30	22
	33	12	5315-01-110-7835	37	7
5310-01-056-1371	20	52	5315-01-145-6080	7	4
5310-01-075-0991	13	10	5315-01-210-0616	7	19
5310-01-079-6529	21	8	5320-01-163-2277	8	11
5310-01-079-6708	21	6	5325-00-256-2846	24	24
5310-01-097-6961	40	5		24	46
5310-01-097-6978	39	20	5325-00-420-9696	36	9
5310-01-097-8039	20	55	5325-00-558-9412	24	18
5310-01-102-3270	32	23	5325-00-804-2784	6	6
5310-01-102-7356	33	16	5325-00-807-2636	30	42
5310-01-103-6042	10	37	5325-00-815-1137	21	16
5310-01-104-4549	37	25	5325-00-922-9101	20	21
5310-01-104-4550	39	9	5325-01-081-0662	30	15
5310-01-112-4306	16	16	5325-01-084-9033	13	29
5310-01-112-4307	20	6	5325-01-087-8727	18	15
	23	5	5325-01-139-6738	11	28
	30	5	5325-01-241-4318	6	6
5310-01-124-6463	17	14	5325-01-449-3299	28	25
5310-01-126-1045	17	13	5330-00-003-1771	14	36
5310-01-126-9404	12	25	5330-00-005-0407	36	3
5310-01-142-2812	24	13	5330-00-005-0858	4	4
5310-01-144-6115	1	2	5330-00-026-2931	17	19
	17	3	5330-00-064-4399	2	3
	18	34	5330-00-129-9389	20	32
5310-01-144-6224	13	16	5330-00-131-7072	20	13
5310-01-145-0761	24	9	5330-00-132-0247	21	18
5310-01-145-0762	36	18	5330-00-132-0248	11	49
5310-01-145-1114	21	8	5330-00-132-0276	21	11
5310-01-145-8403	14	27	5330-00-135-6382	16	6
5310-01-145-8404	16	16	5330-00-143-8376	13	34
5310-01-145-8405	17	10	5330-00-171-7267	2	32
	18	12	5330-00-194-8385	26	8
5310-01-146-6147	32	8		28	3
5310-01-146-6150	32	7	5330-00-237-6266	27	2
5310-01-146-7302	18	8	5330-00-246-0309	12	30
5310-01-146-7303	32	18	5330-00-252-8888	31	16
5310-01-147-5072	18	28	5330-00-286-0487	31	18
5310-01-157-3762	18	8	5330-00-361-2955	4	1
5310-01-270-8245	28	26	5330-00-403-9896	24	21
5310-01-287-9737	26	13	5330-00-404-2920	5	27
5310-01-303-8583	28	13	5330-00-406-7789	27	15
5310-01-497-2856	28	14	5330-00-484-9937	27	11
5315-00-014-1195	2	18	5330-00-506-4866	30	30
5315-00-014-1244	25	4	5330-00-537-2382	2	13
5315-00-014-1284	5	22		11	3
5315-00-043-1787	13	22	5330-00-562-1176	30	41
5315-00-082-0448	24	59	5330-00-567-3463	25	2
	30	31	5330-00-599-2962	24	21
5315-00-238-0882	16	9	5330-00-632-6182	27	12
5315-00-281-7610	2	7	5330-00-659-3178	15	4
5315-00-475-2574	13	21	5330-00-852-7347	20	15
5315-00-532-9388	2	20	5330-00-861-8592	8	32
5315-00-777-3544	7	20	5330-00-864-5422	34	7
	7	26	5330-00-961-9470	24	32
5315-00-844-0140	24	38	5330-01-040-2087	34	5

CROSS REFERENCE INDEXES

NATIONAL STOCK NUMBER INDEX

STOCK NUMBER	FIGURE NO	ITEM NO	STOCK NUMBER	FIGURE NO	ITEM NO
5330-01-043-4242	28	23	5330-01-164-0944	11	48
5330-01-046-1991	11	26	5330-01-181-0630	19	11
5330-01-046-3144	11	16	5330-01-181-0631	20	5
5330-01-049-0466	2	4	5330-01-222-2306	10	45
5330-01-051-4243	13	12	5330-01-240-1619	4	11
	24	20	5330-01-240-1630	36	6
5330-01-060-9061	20	43	5330-01-285-4827	9	6
5330-01-066-3904	14	7	5330-01-291-6537	29	15
5330-01-066-3910	13	2	5330-01-303-1600	28	6
5330-01-066-5350	36	16	5330-01-338-4829	30	29
5330-01-066-5351	14	3	5330-01-497-4872	28	18
5330-01-072-8828	30	9	5331-00-058-1767	2	5
5330-01-072-8830	24	11	5331-00-081-9289	24	55
	30	38	5331-00-081-9299	29	9
5330-01-072-8998	26	1	5331-00-132-0274	29	11
5330-01-075-0948	KIT	3	5331-00-143-8485	3	22
5330-01-079-6514	10	30	5331-00-159-1464	34	16
	11	39	5331-00-420-9624	4	5
5330-01-080-2992	36	12	5331-00-441-0145	20	50
	36	20	5331-00-506-4874	34	2
5330-01-080-5021	3	23	5331-00-809-2667	31	8
5330-01-082-6984	14	17	5331-00-809-3276	31	6
5330-01-082-6985	5	25	5331-00-905-2679	20	41
5330-01-084-9068	31	18	5331-00-941-3762	20	49
5330-01-085-3580	27	1	5331-00-970-3461	24	14
5330-01-086-3523	14	33	5331-00-984-3756	8	28
5330-01-086-3996	18	24	5331-01-072-4436	3	6
5330-01-086-6196	18	7	5331-01-072-8983	24	52
5330-01-086-6197	11	29	5331-01-077-5228	11	36
5330-01-086-7790	KIT	12		34	24
5330-01-092-4143	KIT	4	5331-01-085-3105	18	6
5330-01-097-7791	20	57	5331-01-086-1013	18	5
5330-01-107-1841	45	23	5331-01-086-3991	36	23
5330-01-129-6541	17	16	5331-01-145-0715	13	47
5330-01-136-8569	25	13	5331-01-145-0716	16	5
5330-01-142-2784	24	8	5331-01-145-5377	2	38
5330-01-145-3983	7	8	5331-01-145-6085	10	5
5330-01-145-3984	7	8	5331-01-145-6086	10	18
5330-01-145-5374	27	17	5331-01-154-4316	10	23
5330-01-145-5380	34	10	5331-01-344-4226	28	24
5330-01-145-5381	34	27	5340-00-050-1600	2	15
5330-01-145-6083	8	25	5340-00-084-7787	29	8
	18	25	5340-00-087-7486	14	19
5330-01-145-6909	10	22	5340-00-132-3203	15	9
5330-01-145-6910	10	10	5340-00-238-5435	21	1
5330-01-145-6911	10	9	5340-00-276-5847	2	31
5330-01-145-6913	13	34	5340-00-400-3449	26	11
5330-01-145-6914	16	11	5340-00-404-2940	8	10
5330-01-146-7172	7	8	5340-00-404-2944	7	1
5330-01-146-7314	34	17	5340-00-417-5800	12	26
	36	30	5340-00-485-0945	7	12
5330-01-146-9775	7	8	5340-00-632-6239	3	5
5330-01-146-9928	7	8	5340-00-716-4975	24	44
5330-01-147-0748	12	1	5340-00-719-4601	22	8
5330-01-147-1274	13	2	5340-00-767-4012	15	11
5330-01-147-4071	13	49	5340-00-799-0843	2	12
5330-01-147-4072	14	8	5340-00-809-1490	32	24
5330-01-147-8754	32	3	5340-00-829-5617	31	10
5330-01-150-9812	KIT	10	5340-00-839-0653	12	19
5330-01-155-3349	27	10	5340-00-898-1497	30	43
5330-01-160-7460	23	8	5340-00-907-8964	30	47

CROSS REFERENCE INDEXES

NATIONAL STOCK NUMBER INDEX

STOCK NUMBER	FIGURE NO	ITEM NO	STOCK NUMBER	FIGURE NO	ITEM NO
5340-00-933-3009	3	3	5360-01-089-9103	18	21
5340-00-951-3536	31	7	5360-01-095-3661	24	61
5340-01-066-2947	13	39		30	33
5340-01-079-8097	22	6	5360-01-134-5602	24	23
5340-01-085-4439	18	16	5360-01-138-6638	24	69
5340-01-086-6193	3	14	5360-01-145-3974	10	15
5340-01-087-0681	3	9	5360-01-145-3975	10	17
5340-01-087-0682	3	13	5360-01-145-7554	13	13
5340-01-122-8002	5	26	5360-01-145-7555	18	22
5340-01-135-7250	34	21	5360-01-145-7607	18	11
5340-01-145-0647	21	7	5360-01-147-0054	24	16
5340-01-145-0772	10	43	5360-01-147-4846	30	49
5340-01-145-0773	14	31	5360-01-148-0303	13	15
5340-01-145-0802	13	14	5360-01-200-0323	11	32
5340-01-145-1181	32	5	5365-00-132-0273	6	9
5340-01-145-1597	35	2	5365-00-197-9327	11	24
5340-01-145-9362	2	17		12	11
5340-01-145-9451	13	3	5365-00-369-4729	20	38
5340-01-146-9992	12	5	5365-00-404-2934	36	27
5340-01-147-5389	12	32	5365-00-428-6201	4	10
5340-01-150-6248	12	37	5365-00-462-4504	30	44
5340-01-153-9425	12	44	5365-00-488-0799	2	39
5340-01-163-7118	8	26	5365-00-507-3224	24	68
5340-01-208-9319	33	15	5365-00-507-3225	24	68
5340-01-242-0805	11	10	5365-00-507-3254	16	4
5340-01-342-3610	11	19	5365-00-507-3260	30	45
5340-01-497-7593	28	12	5365-00-507-3261	30	44
5340-01-K72-3663	28	27	5365-00-507-3262	30	44
5342-00-400-5178	24	37	5365-00-507-3271	24	31
5342-00-404-2946	1	5	5365-00-543-3744	24	68
5342-00-858-3507	22	4	5365-00-598-5255	19	14
5342-01-079-4678	21	14		19	18
5342-01-085-4153	23	3		26	21
	30	2	5365-00-695-1247	12	12
5342-01-098-0175	17	7	5365-00-708-3434	11	14
5342-01-140-7158	12	29	5365-00-716-5496	KIT	1
5342-01-143-6045	12	9	5365-00-829-5604	24	65
5342-01-143-6046	30	39	5365-00-965-0870	31	9
5342-01-145-0645	13	11	5365-01-079-8373	24	17
5342-01-145-0646	21	2	5365-01-080-0409	36	22
5342-01-145-1549	24	62	5365-01-086-7788	16	4
5342-01-145-9540	12	20	5365-01-095-5666	17	9
	14	22	5365-01-103-7835	39	6
5342-01-146-9816	32	13	5365-01-126-3334	30	10
5355-00-082-1189	29	16	5365-01-132-1984	36	10
5355-01-084-5323	45	11	5365-01-147-0912	16	4
5355-01-097-7072	45	6	5365-01-147-0913	16	4
5360-00-009-9270	3	4	5365-01-147-2495	2	39
5360-00-129-9415	20	44	5365-01-147-2496	2	39
5360-00-132-0245	21	9	5365-01-147-2497	2	39
5360-00-436-7340	33	3	5365-01-147-5030	1	4
5360-00-461-5738	30	46		17	4
5360-00-597-4570	24	33		18	33
5360-00-664-5343	11	23	5365-01-147-9802	2	39
5360-00-895-3216	20	39	5365-01-148-8353	2	39
5360-00-901-9644	30	46	5365-01-150-6257	2	28
5360-01-038-4659	13	13	5365-01-241-3903	9	7
5360-01-084-9066	18	17	5930-01-095-9823	32	10
5360-01-086-3480	20	47	5930-01-177-0346	10	21
5360-01-086-6113	24	16	5930-01-295-0912	32	10
5360-01-086-6114	24	69	5940-01-085-4426	18	10

CROSS REFERENCE INDEXES

NATIONAL STOCK NUMBER INDEX

STOCK NUMBER	FIGURE NO	ITEM NO	STOCK NUMBER	FIGURE NO	ITEM NO
6150-01-114-7119	18	3	6685-01-141-0907	34	6
6620-01-147-9954	37	1	7690-01-080-7335	32	11
6620-01-203-4301	32	16	7690-01-094-6720	1	8
6625-01-232-5469	42	4	7920-00-168-3244	48	2
6635-01-329-2210	51	5	8115-01-349-2459	1	10
6680-01-085-2870	30	1	9905-00-473-7260	20	27
	30	18	9905-00-733-7622	24	28
6680-01-108-7410	12	23	9905-01-147-0933	1	8
6685-01-047-2811	34	6			

CROSS REFERENCE INDEXES

PART NUMBER INDEX

PART NUMBER	FIG.	ITEM
A77505	13	5
AC1600300NF	26	18
AN565F428H24	24	70
AN737TW22	22	23
AN960-416	25	16
	25	20
	30	36
	31	13
	33	14
AR-09999	11	27
AR-2308	8	6
AR-45724	17	30
AR-73350	KIT	2
AR01176	KIT	1
AR09832	13	25
AR10172	13	1
AR1092200	20	29
AR12228	31	20
AR41010	24	49
AR41022	24	35
AR51323	33	1
AR8667	13	3
AR9832	13	43
AS0401100MS	13	50
B1821BH025C125N	31	2
B1821BH025C350N	10	40
B1821BH031C150N	19	5
B1821BH038C075N	12	31
	13	9
	13	48
	14	12
	14	24
B1821BH038C100D	13	48
B1821BH038C125N	10	32
	13	28
	13	35
	14	10
	26	3
B1821BH038C150N	10	26
	14	39
B1821BH038C200N	10	29
B1821BH038C225N	10	39
B1821BH038F150N	5	2
B1821BH044C175N	20	3
B1821BH044C425N	12	33
B2568	2	20
BM70796	30	48
BM78793	31	17
BM95159	8	12
BM95160	8	16
BM95161	8	2
BM95162	8	20
BM97497	25	3
C3159X2	2	9
COV-1109Z1	12	44
EST1228	41	14
F1801-040	27	5
F40B	38	9
FC3619RX	23	6
H231	3	2
J 33113	53	5

CROSS REFERENCE INDEXES

PART NUMBER INDEX

PART NUMBER	FIG.	ITEM
K060436	36	28
M-1302B-24	38	12
M-A162-20018	32	11
M1302B18	38	13
M39807	4	4
MA145B21000	13	33
MA207-21-642	33	2
MA326 21 180	45	2
MA326-21373	41	24
MB320-20011	12	43
MB362-20001	32	18
MB70-20107	33	15
MODEL CD3	52	5
MS122032	10	41
	14	13
	22	2
	31	12
	33	13
MS16625-1100	30	42
MS16625-1200	6	6
MS16629-1100	24	18
MS16632-1050	24	24
	24	46
MS18154-59	13	9
MS21333-98	32	24
MS27183-11	30	25
MS27183-12	12	41
	34	20
MS27183-14	5	7
	10	27
	12	27
	13	36
	14	26
MS27183-16	12	35
MS27183-21	12	18
MS35308-458	12	21
	14	20
MS35338-45	12	40
	19	6
	20	10
	30	28
MS35338-46	10	38
	12	46
	13	32
	22	25
	32	20
MS35338-47	12	34
	13	27
	16	21
	20	33
	30	3
MS35338-48	1	3
	5	20
	11	8
MS35338-8	11	17
	11	40
MS35648-8	2	15
MS35691-5	24	43
	33	9
	33	12
MS35756-34	13	22

CROSS REFERENCE INDEXES

PART NUMBER INDEX

PART NUMBER	FIG.	ITEM
MS49005-4	2	10
MS51092-1	26	2
MS51967-20	36	17
MS51968-14	8	3
	8	7
	8	13
	8	17
	8	21
MS90725-34	14	37
MS90725-43	20	9
MS90725-6	26	12
MS90725-90	12	39
S-1002-A	10	44
	19	12
	26	25
S-1003-A	19	14
	19	18
	26	21
S-108-A	13	28
S-109	22	27
S-117	22	5
S-119-C	16	14
S-122-C	20	2
	23	1
S-129	7	10
	12	22
S-142-A	13	46
S-151C	22	29
S-159-B	33	5
S-16052	30	16
S-16255	36	21
S-174-C	31	5
S-189-B	5	15
S-189-C	29	1
S-199-B	10	33
S-213-A	12	16
	24	6
S-217	20	7
S-222-A	27	4
S-223	14	23
	22	1
S-2286	1	7
	20	28
	24	29
S-285	17	6
S-603	12	17
	14	21
S-604	10	3
	10	31
	12	17
	13	27
	14	13
	14	25
	22	2
S-626	12	4
	19	7
	20	11
S-631	10	42
	24	3
	27	6
S-908	10	7

CROSS REFERENCE INDEXES

PART NUMBER INDEX

PART NUMBER	FIG.	ITEM
S-911-B	3	24
	16	10
	17	31
	19	10
	36	4
S-915-A	2	26
S-932-B	34	12
S-965-E	36	27
S-966E	2	14
S00100500A	19	16
S00109700	22	12
S105	13	31
	30	40
S105X	24	25
S110	30	26
S118A	26	12
S126	11	18
S129	2	35
S1354	12	47
S145	11	7
S149A	14	30
S151	30	4
S152B	11	44
S155	15	5
S16255	36	11
S190C	22	7
S200	5	21
S223	13	40
S2286	26	23
S248	24	48
S2876	33	6
S600	33	8
S601	5	17
S604	2	34
	7	9
	36	32
S622	13	36
S627	11	45
S631	22	3
S684	14	36
S689	22	26
S719	2	31
S911B	2	27
	5	23
	11	35
	14	40
S962	12	10
SAEJ1508-06	35	6
SINL-200	49	9
ST-1032	41	3
ST-1059-17	42	2
ST-1089	50	6
ST-1090	45	15
ST-1090-3	45	18
ST-1090-4	45	16
ST-1095	46	3
ST-1100	40	3
ST-1100-1	40	7
ST-1100-10	40	4
ST-1100-11	40	10
ST-1100-12	40	14

CROSS REFERENCE INDEXES

PART NUMBER INDEX

PART NUMBER	FIG.	ITEM
ST-1100-13	40	13
ST-1100-14	40	12
ST-1100-5	40	6
ST-1100-6	40	9
ST-1100-7	40	5
ST-1100-8	40	8
ST-1100-9	40	11
ST-1105	47	7
ST-1114	38	3
ST-1122	48	3
ST-1124	48	4
ST-1134	50	7
ST-1145	45	19
ST-1158	44	14
ST-1159	38	15
ST-1168	44	1
ST-1168-10	44	7
ST-1168-19	44	8
ST-1168-3	44	4
ST-1168-4	44	2
ST-1168-5	44	5
ST-1168-6	44	3
ST-1168-7	44	6
ST-1168-8	44	9
ST-1168-9	44	10
ST-1173	48	5
ST-1179	37	29
ST-1191	48	6
ST-1218	40	15
ST-1227	37	15
ST-1228-1	41	23
ST-1228-13	41	17
ST-1228-14	41	21
ST-1228-2	41	22
ST-1228-3	41	15
ST-1228-4	41	20
ST-1228-5	41	18
ST-1228-9	41	16
ST-1231	45	27
ST-1241	50	5
ST-1242	37	4
ST-1242-1	37	12
ST-1242-2	37	6
ST-1242-3	37	5
ST-1242-4	37	8
ST-1242-5	37	9
ST-1242-6	37	7
ST-1242-7	37	10
ST-1242-8	37	11
ST-1244-1	39	7
ST-1244-3	39	10
ST-1244-4	39	9
ST-1244-5	39	8
ST-1244-8	39	11
ST-1244-9	39	6
ST-125	47	1
ST-1254	53	4
ST-1259	43	1
ST-1259-1	43	3
ST-1259-2	43	4
ST-1259-3	43	5

CROSS REFERENCE INDEXES

PART NUMBER INDEX

PART NUMBER	FIG.	ITEM
ST-1259-4	43	2
ST-1259-5	43	7
ST-1259-6	41	8
	43	8
ST-1259-7	43	6
ST-1261	51	1
ST-1262	51	2
ST-1273	37	1
ST-1279	48	9
ST-1287-10	44	13
ST-1298	51	3
ST-1318	44	17
ST-1318-23	44	18
ST-1325	38	16
ST-1326	45	20
ST-1326-1	45	22
ST-1326-2	45	21
ST-249	40	16
ST-249-1	40	20
ST-249-2	40	19
ST-249-3	40	18
ST-249-4	40	17
ST-257	47	2
ST-302	38	2
ST-386-10	39	24
ST-386-11	39	21
ST-386-2	39	19
ST-386-3	39	20
ST-386-5	39	22
ST-386-6	39	27
ST-386-8	39	26
ST-386-9	39	25
ST-422	45	25
ST-448	47	3
ST-544	44	11
	46	4
ST-544-1	46	6
ST-544-2	46	5
ST-560	37	28
ST-561	50	1
ST-563	50	2
ST-608	46	2
ST-633	39	28
ST-658	39	17
ST-659	40	21
ST-663	47	8
ST-669	38	8
ST-669-13	38	10
ST-691	39	13
ST-691-1	39	14
ST-691-2	39	15
ST-6991	38	14
ST-749	47	6
ST-788	37	13
ST-835	41	1
ST-851	46	7
ST-853	41	2
ST-876	48	2
ST-880	37	21
ST-880-1	37	22
ST-880-2	37	23

CROSS REFERENCE INDEXES

PART NUMBER INDEX

PART NUMBER	FIG.	ITEM
ST-880-3	37	24
ST-880-6	37	25
ST-880-7	37	26
ST-884	37	16
ST-884-1	37	17
ST-884-3	37	18
ST-884-6	37	19
ST-903	42	6
ST-995	37	20
ST-997-6	41	5
ST1065	41	13
ST1177	42	5
ST583	47	4
ST593	40	1
ST662	47	9
ST691-3	39	16
ST790-362	53	2
ST790-363	53	3
ST824	48	1
TM-82	38	11
WW-P-471AASBUC	36	5
001022	18	17
001023	18	15
001026	18	8
001030	17	10
	18	12
001031	18	9
001082	18	6
001083	18	7
001094	1	2
	17	3
	18	34
001199	18	31
001234	1	4
	17	4
	18	33
001492	18	13
001519	18	21
001521	18	20
002299	18	10
002390	18	3
002514	18	28
002680	18	35
002969	18	26
003251	17	9
004089	18	14
004136	18	23
007447	18	11
007500	18	22
007505	18	20
007623	18	18
007696	18	19
008895	18	16
009353	18	8
009916	18	9
009917	18	2
010180	8	25
	18	25
011494	49	10
011573	3	19
012647	17	1

CROSS REFERENCE INDEXES

PART NUMBER INDEX

PART NUMBER	FIG.	ITEM
013472	18	4
100099	31	8
100129	25	21
100193	24	41
10021500	25	18
100475	13	29
100478	24	55
100764	30	30
101037-05	32	14
101322	9	1
101841	24	68
101842	24	68
101843	24	68
101996	10	20
102030	32	8
102522	34	23
103031	32	7
103879	12	8
105182	13	37
105199	15	6
105375	24	28
106289	5	13
107460	14	19
107738	7	24
107947	10	36
	11	12
108289	32	13
108330	14	25
	22	3
108722	26	11
109319	13	45
109333	13	14
109594	15	10
	35	3
110058	24	44
110266	15	7
110855	25	2
110907	11	14
111025	32	3
112302	36	9
114638	15	8
116122	20	1
	23	2
116390	17	27
116391	17	32
11669835	1	9
116982	15	11
117244	10	6
	11	21
	16	13
	24	30
118227	24	38
118377	7	23
118378	7	17
118939	7	20
	7	26
11920-001-00	25	9
11936300	25	11
11981000	20	22
119859	20	21
120217	29	6

CROSS REFERENCE INDEXES

PART NUMBER INDEX

PART NUMBER	FIG.	ITEM
120392	10	37
1232	18	30
123558	3	8
12389942	1	10
125049	32	6
126304	13	44
127316	4	15
	5	14
127558	11	22
127936	20	49
127940	20	40
128080	20	39
128085	20	41
128086	20	50
129768	29	10
129826	29	17
129838	29	16
129839	29	8
129866	22	19
	31	19
129888	29	9
12Z329PC92	24	30
12Z9026-5	24	21
130118	34	1
130394	34	26
131026	3	22
131245	32	21
132019	2	12
13264800	2	33
132770	16	2
13294	18	24
133538	31	11
134074	29	7
134561	12	32
135308	3	26
136403	20	27
137075	4	5
137370	30	47
137795	10	2
137796	22	7
138769	24	69
138781	24	69
139988	31	6
140218	2	21
140330	8	5
	8	15
	8	23
	8	19
141244	25	4
141284	5	22
142110	11	20
142689	17	20
143251	30	46
143253	30	46
143848	24	61
	30	33
144178	24	59
	30	31
144179	24	60
	30	32
144302	24	65

CROSS REFERENCE INDEXES

PART NUMBER INDEX

PART NUMBER	FIG.	ITEM
144714	20	42
144948	20	45
145028	20	46
145504	13	12
	24	20
145505	24	19
145506	36	23
1459-259	2	19
	34	30
146160	30	25
146161	13	10
14648300	24	34
147100	3	21
147135	22	4
147389	3	17
147610	20	26
149105PC183049	2	5
14978	20	52
151478	15	3
151489	15	1
153338	31	10
153346	31	14
153964	20	12
154018	20	15
154088	24	32
155789	14	11
156416	27	7
156420	27	13
156444	27	2
157088	24	31
157281	4	8
157282	4	8
157551	13	34
160514	31	9
162426	23	9
	30	27
163733	24	37
163944	30	17
166009	21	9
166777	17	5
167157	21	12
168306	8	4
	8	8
	8	14
	8	18
	8	22
168319	8	24
170226	1	5
170296	3	3
170510	27	12
170664	17	25
170970	22	28
171570	27	16
172034	3	5
172648	5	27
173086	21	18
173368	11	49
173708	33	10
173717	33	3
174299	21	16
175755	6	6

CROSS REFERENCE INDEXES

PART NUMBER INDEX

PART NUMBER	FIG.	ITEM
175831	7	12
175833	17	12
175860	25	6
17586400	25	12
175867	25	5
176027	20	32
1764	18	27
17741900	13	23
178074	12	29
179063	11	34
	13	18
179822	24	16
179834	24	16
179901	35	4
179902	35	12
179903	35	8
179904	35	6
179912.	35	7
180175	5	9
180371	22	6
180372	22	8
180810	20	19
181213	3	25
	22	13
181466	24	26
	25	8
	29	2
	31	3
182706	36	15
183429	20	38
183695	13	22
185138	21	14
185573	16	4
186780	34	7
187317	19	15
187420	6	9
1875350	20	18
187556	29	5
189800	30	44
190334	20	44
190397	17	18
190876	29	11
191037	20	48
191916	21	1
191970	6	7
193136	17	14
193625	12	2
193734	24	21
193736	21	11
194010	27	9
194037	8	10
195755	24	45
195952	14	7
196282	19	9
	34	12
196844	36	10
199349	20	4
199453	12	23
199586	13	7
199589	13	30
20000	32	2

CROSS REFERENCE INDEXES

PART NUMBER INDEX

PART NUMBER	FIG.	ITEM
200064	12	26
200566	15	2
20063500	24	58
200861	5	8
	11	46
200919	15	9
201049	28	23
201250	27	8
201737	34	6
202069	21	3
2021-20-20S	13	42
202128	11	32
202185	22	11
20229	18	5
202377	27	15
202456	27	11
202897	31	7
202903	4	9
203097	36	14
203131	3	18
203145	13	2
20335000	24	67
203426	21	15
203619	30	19
203760	16	16
204163	35	10
204165	4	14
	5	10
204244	27	19
204586	34	6
20483200	13	24
205451	31	4
2062200	12	48
206326	23	10
	30	6
208084	8	11
208119	36	25
208120	36	22
208128	34	5
208326JB1	26	5
208346	2	22
208525	21	8
208829	17	7
209760	24	36
209919	4	2
209955	26	10
210179	4	17
210416	16	3
210707	11	33
210884	2	28
21091500	11	31
210916	34	9
210966	11	10
210967	11	19
211255	16	6
211315	20	43
211435	34	11
211448	35	2
211662	20	36
211918	4	12
211939	13	13

CROSS REFERENCE INDEXES

PART NUMBER INDEX

PART NUMBER	FIG.	ITEM
211999	3	4
212161	11	36
	34	24
212601	30	21
212602	30	23
212603	30	9
212604	30	15
21260500	30	14
212607	30	8
212609	30	11
212610	30	12
212613	30	24
212639	30	13
212668	30	22
212954	21	5
213079	31	18
213082	36	18
213394	3	13
213395	3	9
213456	16	17
213485	34	15
213559	7	18
213740.	2	2
213768	24	52
213769	24	57
214086	27	18
21413900	24	42
214144	24	47
214146	24	22
214150	24	9
214306	16	18
214345	34	4
214617	34	21
214730	6	3
214836	14	34
214951	6	12
214952	6	12
214953	6	12
21504100	14	35
215042	34	3
215044	14	3
215045	14	17
215090	2	3
215195	26	10
215233	7	3
21539700	36	26
215587	14	18
215705	16	5
215965	4	16
21609300	19	13
216128	22	11
216165	4	2
216296	8	26
216487	26	1
216524	3	14
216802	27	1
216804	27	10
21690800	30	8
217034	17	2
217315	11	13
21732300	4	13

CROSS REFERENCE INDEXES

PART NUMBER INDEX

PART NUMBER	FIG.	ITEM
217632	15	12
21773600	27	10
217798	24	39
217929	7	6
217932	14	16
217933	14	14
217934	12	20
	14	22
217939	19	4
218153	8	9
218245	11	26
218716	16	15
218736	8	27
218793	20	14
218813	12	37
219107	7	25
219153	6	11
219191	16	13
2304	40	22
237303	20	57
2380	38	4
2436161	32	23
248X4	22	31
255622	31	18
2580-6	35	13
	BULK	3
26384	12	30
272547	32	19
275707	20	56
28430	BULK	1
2856	18	29
299670	10	34
	11	43
3000082	16	16
3000171	17	22
3000173	17	24
3000174	17	26
	20	35
3000266	29	13
3000446	24	56
3000464	21	10
3000465	21	6
3000521	34	16
3000560	26	15
3000888	36	2
3000907	11	6
3001296	23	3
	30	2
3001646	5	24
3001707	24	17
3001847	24	40
3002069	7	19
300207400	19	1
3002110	30	7
3002385	36	16
3002731	27	3
3002901	7	2
3003156	24	11
	30	38
3003480	1	6
300353600	26	19

CROSS REFERENCE INDEXES

PART NUMBER INDEX

PART NUMBER	FIG.	ITEM
3003682	21	2
3003814	11	11
3004724	30	10
3005133	17	11
3005152	20	37
300550700	36	13
3005508	14	5
3006182	9	2
3006183	9	4
3006187	9	3
3006343	24	51
3006344	24	50
3006349	9	3
3006358	9	5
3006456	3	15
3006457	3	15
3006458	3	15
3006745	11	28
3007442	2	38
3007713	11	29
3007759	3	6
3008017	10	30
	11	39
3008047	2	25
3008048	2	24
3008049	2	23
3008069	12	36
3008468	12	8
3008469	2	8
	5	18
3008470	12	9
3008530	16	23
3008591	14	33
3008596	12	13
300869	13	41
3008690	11	4
3008706	21	17
3008947	17	16
3008998	2	4
3009213	2	21
300938000	24	67
3010030	11	16
3010042	24	35
3010146	13	13
3010242	KIT	3
3010589	8	31
3010590	17	29
3010594	4	3
3010595	11	9
	12	28
	34	8
3010596	11	15
	11	38
	33	17
	34	29
	35	1
3010597	11	42
	34	13
3010810	24	62
3010915	15	13
	26	7

CROSS REFERENCE INDEXES

PART NUMBER INDEX

PART NUMBER	FIG.	ITEM
301123300	11	2
3011342	11	1
3011610	14	27
3011711	16	12
3011712	16	12
3011713	16	7
3011714	16	20
3011715	16	22
3011934	3	7
3011951	2	30
3011952	2	17
3012331	6	1
301233200	6	2
3012462	7	6
3012468	36	29
3012469	36	31
3012470	34	19
3012471	14	10
3012473	14	24
3012479	13	46
3012481	23	4
3012483	5	16
3012526	17	13
3012529	13	14
3012531	13	23
3012532	13	20
3012538	21	13
3012558	24	2
3012726	13	11
3013000	34	28
3013161	22	14
3013295	14	2
3013331	7	19
3013336	17	15
3013591	2	37
3013623	3	28
3013786	2	16
	13	5
	36	5
301381000	24	12
3013811	24	10
3013904	2	11
	12	45
3013909	2	6
3013930	6	8
3014354	26	9
301439700	22	17
301439800	22	15
3014614	4	16
3014622	3	10
3014623	3	10
3014624	3	10
3014625	3	10
3014754	13	16
3014755	13	17
3014756	13	15
3014778	13	2
3014783	13	19
3014787	13	19
3014788	13	8
3014798	13	25

CROSS REFERENCE INDEXES

PART NUMBER INDEX

PART NUMBER	FIG.	ITEM
3014964	13	3
3015114	34	3
3015282	20	34
	23	7
3015373	22	9
3015375	22	18
3015387	22	18
3015389	22	16
3015393	22	16
3015469	21	8
301552000	24	5
301552200	24	4
3016637	5	19
3016887	7	14
3017049	12	36
3017051	30	19
	30	35
	31	2
3017052	30	40
3017748	34	11
3017750	8	32
3017759	3	10
3018098	34	15
3018099	14	35
3018153	20	24
3018488	20	16
3018655	24	23
3018686	26	4
3018690	10	11
3018695	10	23
3018697	10	43
3018762	KIT	4
3018764	34	9
3018767	30	49
3018889	22	22
3019158	34	10
3019218	4	8
3019572	14	15
3019573	20	31
3019574	17	8
3019955	2	39
3019956	2	39
3019957	2	39
3019958	2	39
3019959	2	39
3019960	2	39
3020183	4	11
3020753	22	30
3020754	22	24
3020760	22	21
3020943	15	4
3021068	24	22
302109000	29	7
302112400	KIT	5
302136100	13	20
3021470	20	53
3021581	11	30
3021596	7	4
3021656	10	24
3021660	5	11
3021676	24	15

CROSS REFERENCE INDEXES

PART NUMBER INDEX

PART NUMBER	FIG.	ITEM
3021704	16	11
3021735	5	25
3022377	12	24
3022589	34	22
3022590	13	6
	19	8
3022821	22	9
3023088	24	13
3023101	20	47
302317100	24	7
3023473	17	17
3023506	13	30
3023512	10	4
3023556	21	13
3023870	24	8
3024365	20	8
3024442	16	1
3024666	11	37
	34	25
3024709	34	27
3024960	34	17
	36	30
3024991	30	34
3025459	30	39
3025460	24	27
	31	15
302561100	26	14
302586100	36	13
3026034	27	14
3026198	31	1
3026556	17	21
3026557	17	28
3026733	24	68
3026993	27	19
3027282	1	8
3027308	27	8
302746000	10	8
3027633	24	64
3027653	15	14
3028075	2	30
3028171	21	2
3028269	2	30
3028279	21	3
	23	7
3028281	34	18
3028282	14	9
3028642	19	17
3028967	14	30
3029614	15	2
3029846	13	34
3029847	13	47
3029848	13	33
3030038	3	16
3030257	12	7
3030267	30	1
	30	18
3030269	30	1
3030286	14	28
3030803	10	15
3030804	10	13
303080500	10	16

CROSS REFERENCE INDEXES

PART NUMBER INDEX

PART NUMBER	FIG.	ITEM
3030806	10	14
3030808	10	18
3030970	29	12
3031005	10	19
3031186	15	1
3031187	15	3
3031434	13	49
3031560	11	5
3031749	5	5
3031750	5	4
3031751	5	1
3031752	5	3
3031753	5	6
303195900	12	2
3031980	27	3
3032307	10	1
3032348	14	8
3032674	12	38
3032681	7	7
3032708	12	5
3032835	27	18
3033719	25	19
3033724	25	17
3033740	25	15
3034243	25	1
303457800	10	12
3034579	10	45
3034736	27	17
3035028	10	21
3035053	23	8
3035362	29	4
3035595	10	46
	26	20
3035600	26	16
3035607	14	31
3035961	8	1
3036005	5	19
3036285	8	30
3036798	14	32
303689200	26	24
3036933	7	21
3036934	7	27
3036935	7	16
303724200	10	25
3037537	28	24
3038035	12	15
3038037	22	10
3038060	19	13
	19	17
3038218	30	51
3038745	27	14
3038997	36	6
3038998	36	12
	36	20
3039070	24	62
3039296	10	17
3040180	3	23
3041993	3	1
3043647	15	5
3043649	35	11
3043984	26	4

CROSS REFERENCE INDEXES

PART NUMBER INDEX

PART NUMBER	FIG.	ITEM
3045049	25	14
3045173	30	20
3045534	18	32
3045670	20	20
3045979	10	5
3046170	14	4
3046298	20	51
3046680	24	54
3047159	20	13
3047464	10	9
3047465	10	10
3047963	21	7
3047973	21	4
3048296	33	4
3049024	7	5
3050394	36	7
3050624	25	10
3054071	21	4
3054841	9	6
3055069	12	12
3056158	26	13
3056569	7	22
3058664	16	19
3060202-3894	23	6
3060882	11	25
3061420	33	11
3064398	6	4
3064919	36	19
3065125	7	13
3066796	7	11
3067616	4	1
3068724	14	34
3069014	10	22
3069017	25	13
3069101	17	19
3069177	26	8
	28	3
3071085	36	3
3074214	1	8
3074400	7	8
3074401	7	8
3074402	7	8
3074403	7	8
3074404	7	8
3076040	24	53
3077201	14	6
309015	32	10
3095051	12	6
3099083	12	1
320-1850	20	5
3201386	19	11
321030-02	32	16
33-5490-060-000	12	14
3300908	11	47
3305367	35	9
3305L1A	36	8
	36	24
3308958	11	48
3313283	10	35
33405	31	17
3349819	3	23

CROSS REFERENCE INDEXES

PART NUMBER INDEX

PART NUMBER	FIG.	ITEM
3375014	45	26
3375015	45	23
3375108	38	5
3375137	41	12
3375140	41	9
3375146	41	10
3375147	41	11
3375150	37	27
3375151	49	11
3375153	45	1
3375154	41	19
3375162	51	4
3375165	43	10
3375166	43	11
3375172	43	13
3375173	43	14
3375174	43	15
3375180	37	2
	38	6
3375182	49	1
3375192	49	2
3375204	41	6
3375205	39	23
3375207	45	10
3375220	45	5
3375221	45	12
3375222	45	13
3375223	45	3
3375224	45	11
3375225	45	9
3375226	45	8
3375227	45	7
3375228	45	6
3375229	45	4
3375230	45	24
3375232	52	6
3375257	49	5
3375271	46	1
3375282	39	12
3375375	52	4
3375425	37	14
3375432	51	5
3375448	49	6
3375455	47	5
3375599	52	3
3375601	51	6
3375614	39	5
3375615	39	4
3375616	39	3
3375825	39	2
3375834	44	15
3375839	44	16
3375855	46	8
3375959	51	7
3376011	51	8
3376015	52	1
3376050	49	7
3376135	50	3
3376177	45	14
3376197	45	17
3376326	39	18

CROSS REFERENCE INDEXES

PART NUMBER INDEX

PART NUMBER	FIG.	ITEM
	49	8
3376350	53	1
3376464	40	2
3376619	42	4
3376663	48	7
3376669	42	7
3376684	42	1
3376815	49	4
3376816	49	3
3376845	38	7
3376903	42	3
3376904	44	12
3377079	39	1
3397929	38	1
3412285	10	28
3519155	28	7
3519290	28	22
3519401	28	21
3519471	28	13
3520981	28	12
3521119	28	14
3521439	28	19
3521440	28	10
3521441	28	5
3521442	28	6
3521837	28	2
3522075	28	4
3522416	28	29
3526653	28	15
3527047	28	16
3529016	28	11
3529372	28	26
3558653	20	25
3558655	20	23
3608833	4	7
3678	18	27
3709510	28	1
3718373	28	25
3722366	28	9
3723863	28	17
3725CP	6	12
3751948	28	20
3756135	28	8
3757753	28	28
3759618	28	18
3801047	7	5
3801056	KIT	6
3801058	KIT	8
3801096	KIT	7
3801106	KIT	9
3801235	KIT	10
3801260	4	6
3801261	4	6
3801262	4	6
3801263	4	6
3801310	2	6
3801433	8	29
3801708	36	1
	KIT	14
	KIT	15
3801826	2	1

CROSS REFERENCE INDEXES

PART NUMBER INDEX

PART NUMBER	FIG.	ITEM
3801904	26	22
3801942	26	22
3803279	26	22
3803430	28	27
3803512	3	11
3803524	3	12
3803676	30	18
3804280	KIT	12
3804414	6	5
3804416	6	5
3804500	6	2
3804587	18	1
3821572	13	1
3822472	43	12
3822505	37	3
3822696	43	9
3823024	48	10
3823114	41	7
3823495	52	2
3823871	50	4
3824211	41	4
3824277	48	8
3824942	43	16
3903927	29	15
400X3	20	58
4024958	KIT	11
4026171	30	29
41044	12	29
42645	2	25
42646	2	24
444042	32	17
444683	20	30
44678	30	37
450517	11	41
4797	5	12
49X6X2	11	50
501088-02	32	12
501096-04	32	9
5116M40	4	6
538174	3	27
5414243-20	22	10
5561 1-2A	14	1
	19	3
	26	17
5583303	34	14
5704991	43	KIT
	46	KIT
5704993	40	KIT
5704994	46	KIT
5710454	35	7
5730765	35	4
5730769	35	10
5731317	2	36
5739124	KIT	13
57K3603	1	1
590220940406	24	66
5995177	33	7
60408	16	9
60575	4	10
61554	19	2
63842	14	38

CROSS REFERENCE INDEXES

PART NUMBER INDEX

PART NUMBER	FIG.	ITEM
64709	9	7
650330	20	17
65259-A	16	4
65259-B	16	4
65259-C	16	4
66292	2	29
67684	29	3
67946	11	24
	12	11
67963	2	32
68038	13	39
68061-A	24	14
68139	13	51
	22	20
68193	7	1
68274	11	23
68365	13	7
68425	12	19
68445	2	7
68585	2	18
68803-A	3	29
69047-A	14	29
691-10014	31	16
69324	20	6
	23	5
	30	5
69519	13	21
69521	13	4
	13	26
69736	7	15
69832	12	3
70089-1	2	13
	11	3
70295	29	14
70470	35	5
70550	6	10
	17	23
70624	34	2
70653	16	8
70657	5	26
70690	24	63
70700	24	33
70705	30	41
70713	30	43
70715	30	50
70716	30	52
70717	30	45
70717-A	30	44
70717-B	30	44
70772	3	20
70772-B	24	1
70790	25	7
7374401	8	28
829-4151	32	4
8293635	32	10
8294151	32	1
851-202994	26	6
8710557	BULK	2
8710557-10	12	42
913020	32	5
913024-06	32	15

CROSS REFERENCE INDEXES

PART NUMBER INDEX

PART NUMBER	FIG.	ITEM
9417953	20	55
9418993	20	54
9419002	32	22
9421077	33	16
9421196	33	18
9422277	12	25
9674F	13	38
999-1206	50	8

**DIRECT SUPPORT AND GENERAL SUPPORT
MAINTENANCE MANUAL
INCLUDING REPAIR PARTS AND SPECIAL TOOLS LIST (RPSTL)
FOR
M915, M915A1, M915A4, M916, M920 VEHICLES**

NSN 2815-01-082-8125	P/N NTC400-3652-02	CUMMINS NTC-400 BIG CAM III DIESEL ENGINE W/CONTAINER
NSN 2815-01-142-2745	P/N 11669835	CUMMINS NTC-400 BIG CAM III DIESEL ENGINE W/CONTAINER

EXPENDABLE AND DURABLE ITEMS

INTRODUCTION

This Work Package (WP) lists expendable and durable items needed to repair the Cummins NTC-400 diesel engine. This list is for information only and is not authority to requisition the listed items. These items are authorized to you by CTA 50-970, Expendable/Durable Items.

EXPLANATION OF COLUMNS

Column 1—Item Number. Number assigned to each entry for referencing in Materials/Parts lists in WP Initial Setups.

Column 2—National Stock Number (NSN). The number used to requisition an item.

Column 3—Description. Provides information needed to identify the item.

Column 4—Unit of Measure. Shows the unit of measure or count of an item, such as gallon, dozen, gross, etc.

EXPENDABLE AND DURABLE ITEMS (Contd)*Table 1. Expendable and Durable Items List.*

(1) ITEM	(2) NATIONAL STOCK NUMBER	(3) DESCRIPTION	(4) UNIT OF MEASURE
1	—	ACID: muriatic	PT
2	—	ACID: oxalic	PT
3	6850-01-441-3218 6850-01-441-3221 6850-01-441-3223	ANTIFREEZE: permanent ethylene glycol -60° F inhibited, (0-A-548), type I, heavy-duty, single package (58536) (A-A-52624) 1-gallon container 5-gallon can 55-gallon drum	GAL. GAL. GAL.
4	5350-00-221-0872	CLOTH, ABRASIVE (crocus): 9 in. x 11 in. sheets, (58536) A-A-1206 50 sheets/package	PG
5	5390-00-584-4554	CLOTH: emery, 290-grit A-A-1049	SH
6	7920-00-044-9281	CLOTH, CLEANING: lint-free, general purpose, white, (81359) MIL-C-85043 10-pound box	LB
7	8030-00-251-3980	ANTISEIZE COMPOUND: temperature-resistant lubricant, MIL-A-907, Loctite antiseize, 200° F (93° C), with brush top (05972) 76764 1-pound can	LB
8	5350-00-224-6692	COMPOUND: lapping 280-grit, SSL-1682 1-pound can	LB
9	6850-00-664-9067	COMPOUND: Prussian blue, MIL-L-83795 1-pint can	PT
10	6850-01-241-0651	DEVELOPER: spotcheck, SKD-NF 1-pint can	PT
11	9150-00-698-2382	FLUID: automatic transmission, type A, AOATF1562A 1-quart can	QT
12	6850-00-974-3788	FLUID, CALIBRATION-INJECTOR TEST STAND, 45A 1-pint can	PT
13	9150-01-197-7698 9150-01-197-7690 9150-01-197-7689 9150-01-197-7692 9150-00-190-7369	13 C GREASE, AUTOMOTIVE AND ARTILLERY: MIL-G-10924 (81349) 2 1/4-oz tube 1 3/4-pound can 6 1/2-pound can 35-pound can 120-pound drum	OZ LB LB LB LB
14	8030-00-081-2330	LOCTITE: MIL-S-22473 (grade CV) 50-cubic-centimeter bottle	CC

EXPENDABLE AND DURABLE ITEMS (Contd)*Table 1. Expendable and Durable Items List (Contd).*

(1) ITEM	(2) NATIONAL STOCK NUMBER	(3) DESCRIPTION	(4) UNIT OF MEASURE
15	9150-00-458-0075	LUBRICANT: high-pressure Brayco 300 1/16 ounce	OZ
16	9150-00-231-9045	LUBRICANT: rust preventative 1-gallon can	GAL.
17	9150-00-265-9406	CUTTING FLUID: (81348) C-O-376 1-gallon can	GAL.
18	9140-00-286-5294 9140-00-286-5295 9140-00-286-5296 9140-00-256-5297	FUEL: diesel, regular, DF-2, VV-F-800 bulk 5-gallon can 55-gallon drum, 16-gauge 55-gallon drum, 18-gauge	GAL. GAL. GAL. GAL.
19	9150-00-189-6727 9150-00-186-6668 9150-00-191-2772 9150-00-183-7807	OIL, LUBRICATING: OE/HDO 10, MIL-L-2104C 1-quart can 5-gallon drum 55-gallon drum, 18-gauge Bulk	QT GAL. GAL. GAL.
20	9150-00-186-6681 9150-00-188-9858 9150-00-265-9476 9150-00-189-6729 9150-00-183-7808	OIL, LUBRICATING: OE/HDO 30, MIL-L-2104C 1-quart can 5-gallon drum 55-gallon drum, 16-gauge 55-gallon drum, 18-gauge Bulk	QT GAL. GAL. GAL. BULK
21	—	OIL, LUBRICATING: gear 60-80/140, MIL-L-2105C 1-quart can 5-gallon drum 55-gallon drum	QT GAL. GAL.
22	5350-00-543-3600	PAPER: aluminum oxide 240-grit ALOXGRIT 80 90 lbs per ream	REAM
23	6810-00-227-0407	PYRIDINE 16-ounce bottle	OZ
24	8030-00-247-2524	SEALANT: gasket, MIL-S-45180 2-ounce tube	OZ
25	8030-00-204-9149	SEALING COMPOUND: pipe sealant (05972) 59241 250-cubic-centimeter bottle	CC
26	8030-01-104-5392	SEALING COMPOUND: liquid, type II, grade N, Loctite 242 (05972) 24221 10-cubic-centimeter bottle	CC

EXPENDABLE AND DURABLE ITEMS (Contd)*Table 1. Expendable and Durable Items List (Contd).*

(1) ITEM	(2) NATIONAL STOCK NUMBER	(3) DESCRIPTION	(4) UNIT OF MEASURE
27	6810-00-985-7129	SODIUM CARBONATE (5 % solution): MIL-R-23679 2-ounce bottle	OZ
28	—	SOLUTION: soap	—
29	5340-00-450-5718	CAP AND PLUG SET: (19207) 10935405 1 set	EA
30	8030-00-231-2352	CORROSION PREVENTIVE COMPOUND: MIL-C-11796 55-gallon drum	GAL.
31	5970-00-989-1485	TAPE: moisture proof (73030) H57495-618 1 roll	ROLL
32	—	RUBBER GLOVES	PR
33	—	GREASE FITTING	EA
34	7930-01-011-2498	CLEANING COMPOUND, SOLVENT-DETERGENT 19-ounce bottle	OZ

**DIRECT SUPPORT AND GENERAL SUPPORT
MAINTENANCE MANUAL
INCLUDING REPAIR PARTS AND SPECIAL TOOLS LIST (RPSTL)
FOR
M915, M915A1, M915A4, M916, M920 VEHICLES**

NSN 2815-01-082-8125	P/N NTC400-3652-02	CUMMINS NTC-400 BIG CAM I DIESEL ENGINE W/CONTAINER
NSN 2815-01-142-2745	P/N 11669835	CUMMINS NTC-400 BIG CAM III DIESEL ENGINE W/CONTAINER

TOOLS AND SPECIAL TOOLS

SCOPE

This Work Package (WP) lists common and special tools apart from the general mechanic's tool kit needed to service the Cummins NTC-400 Big Cam I and Big Cam III diesel engines.

EXPLANATION OF COLUMNS

Column 1—Item Number. Number assigned to each entry for referencing in the Tools and Special Tools list in WP Initial Setups.

Column 2—Item Name. Name or identification of special or common tool.

Column 3—Part Number. Number used to requisition the tool or kit.

Column 4—National Stock Number. Manufacturer's part number or catalog number assigned to each tool or kit.

TOOLS AND SPECIAL TOOLS (Contd)

Table 1. Tool Identification List.

(1) ITEM NO.	(2) ITEM NAME	(3) PART NO.	(4) NATIONAL STOCK NUMBER
1.	General mechanics tool kit: automotive	SC5180-90-CL-N26	5180-00-177-7033
2.	Maintenance and repair shop equipment: automotive	SC4910-95-CL-A74	4910-00-754-0654
3.	Automotive maintenance and repair supplemental set no. 2	SC4910-95-CL-A63	4910-00-754-0707
4.	Air pressure tester	—	—
5.	Magnetic crack detector	ST-1166	6635-01-128-2676
6.	Solenoid valve wrench	011494	5120-01-163-1349
7.	C-clamp	—	—
8.	Fuel injector puller	3376872	5120-00-116-7604
9.	Ball joint vise	ST-302	4910-00-999-1506
10.	Fuel pump mounting plate	3375133	4910-00-977-7505
11.	Injector stand	ST-1298	4910-01-082-1346
12.	Body and injector cup wrench	ST-995	5120-00-150-7492
13.	Bearing disassembly fixture	ST-1114	4910-01-097-6987
14.	Water pump bearing mandrel	ST-658	4910-01-097-6986
15.	Water pump seal mandrel	3375448	5120-01-128-2675
16.	Oil seal driver	ST-1191	5120-01-160-8867
17.	Oil seal pilot	3375180	4910-01-097-6989
18.	Air compressor wrench	3375159	5120-01-072-2952
19.	Turbocharger mounting plate	—	—
20.	Main shaft seal driver	—	—
21.	Front cover tachometer seal driver	—	—
22.	Main shaft gear and bearing installation tool	3375175	5180-01-074-0019
23.	Oil seal assembly tool	ST-419	5120-00-896-8097
24.	Plunger protrusion checking tool	ST-1241	4910-01-141-8388
25.	Connecting rod bushing driver	ST-1242	4910-01-098-1914
26.	Connecting rod checking fixture	ST-561	4910-00-977-7507
27.	Piston ring groove gauge	ST-560	5210-00-999-1209
28.	Piston ring expander	ST-763	5120-00-150-7486

TOOLS AND SPECIAL TOOLS (Contd)*Table 1. Tool Identification List (Contd).*

(1) ITEM NO.	(2) ITEM NAME	(3) PART NO.	(4) NATIONAL STOCK NUMBER
29.	Oil seal expander	3375151	4910-01-165-4541
30.	Rocker lever block and mandrel set	ST-691	3460-00-999-1210
31.	0.250 in. (6.350 mm) radius gauge	—	—
32.	Split rod	—	—
33.	Puller/installer	ST-1259	4910-01-106-0492
34.	Air compressor mounting plate	ST-749	4910-01-159-8701
35.	Half coupling puller	3376663	5120-01-128-2678
36.	Air compressor bushing mandrel	—	—
37.	Line bore gauge	—	—
38.	Pressurizing valve driver	3375959	4910-01-143-2034
39.	Mandrel	—	—
40.	Gear puller	3375834	5120-01-120-5759
41.	0.125 in. (3.175 mm) diameter rod	—	—
42.	Lifting sling	—	—
43.	Lifting brackets	—	—
44.	Vibration damper guide pin	—	—
45.	Pulley installer	—	—
46.	Camshaft bushing driver kit	3376633	5120-01-146-7131
47.	Cylinder sleeve driver	ST-1229	5120-00-999-1206
48.	Cylinder sleeve clamp	ST-1154	9999-01-128-2866
49.	Gauge block	3376220	5210-01-157-3091
50.	Engine block counterbore tool	3375455	4910-01-150-9713
51.	Bore alignment checking bar	ST-1157	4910-01-097-6913
52.	Universal cylinder liner puller	3376015	5120-01-143-2032
53.	Valve spring compressor	ST-448	5120-01-145-7293
54.	Valve seat extractor	ST-1279	5120-01-128-2679

TOOLS AND SPECIAL TOOLS (Contd)*Table 1. Tool Identification List (Contd).*

(1) ITEM NO.	(2) ITEM NAME	(3) PART NO.	(4) NATIONAL STOCK NUMBER
55.	Expansion plug driver	3375190 3375191 3375192	4910-01-143-3336 4910-01-143-3337 4910-01-143-2023
56.	Valve vacuum tester	ST-1257-A	4910-01-128-2691
57.	Manometer	—	—
58.	Blow-by check tool	3375150	4910-01-085-9211
59.	Engine dynamometer	0058 00-3	4910-01-159-8701
60.	Fuel pump idle adjusting tool	3375981	4910-00-150-5805
61.	Throttle shaft ball installing tool	3375204	4910-01-118-3747
62.	Camshaft pilot tools	3375268	5120-01-332-3597
63.	Pulley installation assembly tool	3376326	5120-01-156-4183
64.	Crankshaft seal driver	ST-997	5120-00-150-5810
65.	Piston ring compressor	3375162	5120-01-128-2758
66.	Dial gauge attachment	ST-1325	4910-01-097-6972
67.	Tilt Sling	—	—
68.	Main bearing cap puller	ST-1178	5120-01-141-5777
69.	AFC barrel puller	3375599	5120-01-128-2688
70.	Big Cam III modification kit	57K2993	—

**DIRECT SUPPORT AND GENERAL SUPPORT
MAINTENANCE MANUAL
INCLUDING REPAIR PARTS AND SPECIAL TOOLS LIST (RPSTL)
FOR
M915, M915A1, M915A4, M916, M920 VEHICLES**

NSN 2815-01-082-8125	P/N NTC400-3652-02	CUMMINS NTC-400 BIG CAM I DIESEL ENGINE W/CONTAINER
NSN 2815-01-142-2745	P/N 11669835	CUMMINS NTC-400 BIG CAM III DIESEL ENGINE W/CONTAINER

MANDATORY REPLACEMENT PARTS

INTRODUCTION

This work package lists mandatory replacement parts you will need to repair the Cummins NTC-400 diesel engine.

This work package includes a list of all mandatory parts referenced in the task initial setups and procedures. These items must be replaced during maintenance whether or not they have failed.

EXPLANATION OF COLUMNS

Column (1) – Item Number. Number assigned to each entry in the listing is is referenced to the task initial setups “Material/Parts” heading.

Column (2) – Nomenclature. Name or identification of the part.

Column (3) – Part Number/CAGEC. The manufactures part number.

Column (4) – National Stock Number. The national stock number of the part.

Column (5) – Repair Parts WP. Reference to figure and item number in Repair Parts WP 0058 00

MANDATORY REPLACEMENT PARTS (Contd)*Table 1. WP 0013 00 Cylinder Block Mandatory Replacement Parts.*

(1) ITEM NO.	(2) NOMENCLATURE	(3) PART NUMBER	(4) NATIONAL STOCK NUMBER	(5) REPAIR PARTS WP 0058 00
1.	Gasket	215090	5330-00-064-4399	Fig. 2, item 3
2.	Black O-ring	3008998	5330-01-049-0466	Fig. 2, item 4
3.	Red O-ring	149105PC183049	5331-00-058-1767	Fig. 2, item 5
4.	Expansion plug	3008469	4730-01-214-7081	Fig. 2, item 8
5.	Expansion plug	3013786	4730-01-161-5115	Fig. 2, item 16
6.	Cap	3011952	5340-01-145-9362	Fig. 2, item 17
7.	Expansion plug	1459-259	4730-00-221-2139	Fig. 2, item 19
8.	Shim	3019955	5365-01-147-9802	Fig. 2, item 39

Table 2. WP 0014 00 Cylinder Head Mandatory Replacement Parts.

(1) ITEM NO.	(2) NOMENCLATURE	(3) PART NUMBER	(4) NATIONAL STOCK NUMBER	(5) REPAIR PARTS WP 0058 00
1.	Upper valve spring retainer	170296	5340-00-933-3009	Fig. 3, item 3
2.	Valve spring	211999	5360-00-009-9270	Fig. 3, item 4
3.	Lower valve spring retainer	172034	5340-00-632-6239	Fig. 3, item 5
4.	Injector O-ring	3007759	5331-01-072-4436	Fig. 3, item 6
5.	Expansion plug 6	213395	5340-01-087-0681	Fig. 3, item 9
6.	Valve seat insert	3017759	2815-00-085-7434	Fig. 3, item 10
7.	Intake valve	3803512	2815-01-354-2702	Fig. 3, item 11
8.	Exhaust valve	3803524	2815-00-962-5623	Fig. 3, item 12
9.	Expansion plug 1	213394	5340-01-087-0682	Fig. 3, item 13
10.	Expansion plug 2	216524	5340-01-086-6193	Fig. 3, item 14
11.	Valve stem guide	3006456	2815-01-085-2618	Fig. 3, item 15
12.	Lockut	203131	5310-00-426-3990	Fig. 3, item 18
13.	O-ring	131026	5331-00-143-8485	Fig. 3, item 22

MANDATORY REPLACEMENT PARTS (Contd)*Table 3. WP 0018 00 Pistons, Connecting Rods, and Bearings Mandatory Replacement Parts.*

(1) ITEM NO.	(2) NOMENCLATURE	(3) PART NUMBER	(4) NATIONAL STOCK NUMBER	(5) REPAIR PARTS WP 0058 00
1.	Bushing	187420	5365-00-132-0273	Fig. 6, item 9
2.	Connecting rod bearing	214951	3120-01-155-4442	Fig. 6, item 12
3.	First compression ring	3012331	2815-00-994-4427	Fig. 6, item 1
4.	Second compression ring	301233200	2815-01-241-6580	Fig. 6, item 2
5.	Intermediate compression ring	214730	2815-01-241-6581	Fig. 6, item 3
6.	Oil control ring	3064398	2815-00-994-4429	Fig. 6, item 4

Table 4. WP 0019 00 Camshaft, Camshaft Followers, and Pushrods Mandatory Replacement Parts.

(1) ITEM NO.	(2) NOMENCLATURE	(3) PART NUMBER	(4) NATIONAL STOCK NUMBER	(5) REPAIR PARTS WP 0058 00
1.	Thrust bearing	215233	3120-01-079-8194	Fig. 7, item 3
2.	Expansion plug	175831	5340-00-485-0945	Fig. 7, item 12

Table 5. WP 0020 00 Rocker Levers and Rocker Lever Housing Mandatory Replacement Parts.

(1) ITEM NO.	(2) NOMENCLATURE	(3) PART NUMBER	(4) NATIONAL STOCK NUMBER	(5) REPAIR PARTS WP 0058 00
1.	O-ring	7374401	5331-00-984-3756	Fig. 8, item 28
2.	Bushing	140330	3120-00-589-3537	Fig. 8, item 15
3.	Ball socket seat	194037	5340-00-404-2940	Fig. 8, item 10

MANDATORY REPLACEMENT PARTS (Contd)*Table 6. WP 0021 00 Oil Cooler Mandatory Replacement Parts.*

(1) ITEM NO.	(2) NOMENCLATURE	(3) PART NUMBER	(4) NATIONAL STOCK NUMBER	(5) REPAIR PARTS WP 0058 00
1.	Lockwasher	S-604	5310-00-261-7340	Fig. 10, item 3
2.	O-ring	3045979	5331-01-145-6085	Fig. 10, item 5
3.	Gasket	3047464	5330-01-145-6911	Fig. 10, item 9
4.	Gasket	3047465	5330-01-145-6910	Fig. 10, item 10
5.	Spring	3030803	5360-01-145-3974	Fig. 10, item 15
6.	Spring	3039296	5360-01-145-3975	Fig. 10, item 17
7.	Gasket	3069014	5330-01-145-6909	Fig. 10, item 22
8.	O-ring	3018695	5331-01-154-4316	Fig. 10, item 23
9.	Oil cooler core	3412285	2930-01-146-1081	Fig. 10, item 28
10.	Vent Valve	107947	4820-00-276-9041	Fig. 11, item 12
11.	Lockwasher	3010596	5305-01-088-6019	Fig. 11, item 15
12.	Gasket	3010030	5330-01-046-3144	Fig. 11, item 16
13.	Spring	68274	5360-00-664-5343	Fig. 11, item 23
14.	Gasket	218245	5330-01-046-1991	Fig. 11, item 26
15.	Retaining ring	3006745	5325-01-139-6738	Fig. 11, item 28
16.	O-ring	3007713	5330-01-086-6197	Fig. 11, item 29
17.	Element	3021581	2930-01-065-7113	Fig. 11, item 30
18.	Spring	202128	5360-01-200-0323	Fig. 11, item 32
19.	Lockwasher	S-627	5310-00-820-6653	Fig. 11, item 45
20.	Gasket	3308958	5330-01-164-0944	Fig. 11, item 48
21.	O-ring	173368	5330-00-132-0248	Fig. 11, item 49

MANDATORY REPLACEMENT PARTS (Contd)*Table 7. WP 0023 00 Oil Pump Mandatory Replacement Parts*

(1) ITEM NO.	(2) NOMENCLATURE	(3) PART NUMBER	(4) NATIONAL STOCK NUMBER	(5) REPAIR PARTS WP 0058 00
1.	Gasket	203145	5330-01-066-3910	Figure 13, item 2 (Big Cam I)
2.	Gasket	3014778	5330-01-147-1274	Figure 13, item 2 (Big Cam III)
3.	Bushing	69521	3120-00-627-6697	Figure 13, item 4
4.	Bushing	68365	3120-00-566-0480	Figure 13, item 7
5.	O-ring	145504	5330-01-051-4243	Figure 13, item 12 (Big Cam III)
6.	Pressure regulator spring	211939	5360-01-038-4659	Figure 13, item 13 (Big Cam I)
7.	Pressure regulator spring	3010146	5360-01-145-7554	Figure 13, item 13 (Big Cam III)
8.	Bypass Valve Spring	3014756	5360-01-148-0303	Figure 13, item 15 (Big Cam III)
9.	Bushing	69521	3120-00-627-6697	Figure 13, item 26
10.	Lockwasher	MS35338-47	5310-00-209-0965	Figure 13, item 27 (Big Cam III)
11.	Lockplate	109319	2815-00-406-8936	Figure 13, item 45 (Big Cam I)

Table 8. WP 0024 00 Air Aftercooler Mandatory Replacement Parts.

(1) ITEM NO.	(2) NOMENCLATURE	(3) PART NUMBER	(4) NATIONAL STOCK NUMBER	(5) REPAIR PARTS WP 0058 00
1.	Gasket	215044	5330-01-066-5351	Fig. 14, item 3
2.	Gasket	3032348	5330-01-147-4072	Fig. 14, item 8
3.	Gasket	3077201	N/A	Fig. 14, item 6
4.	O-ring	195952	5330-01-066-3904	Fig. 14, item 7

Table 9. WP 0025 00 Exhaust Manifold Mandatory Replacement Parts.

(1) ITEM NO.	(2) NOMENCLATURE	(3) PART NUMBER	(4) NATIONAL STOCK NUMBER	(5) REPAIR PARTS WP 0058 00
1.	Spacer insert	3027653	N/A	Fig. 15, item 14

MANDATORY REPLACEMENT PARTS (Contd)*Table 10. WP 0026 00 Turbocharger Mandatory Replacement Parts.*

(1) ITEM NO.	(2) NOMENCLATURE	(3) PART NUMBER	(4) NATIONAL STOCK NUMBER	(5) REPAIR PARTS WP 0058 00
1.	Sleeve	216802	5330-01-085-3580	Fig. 27, item 1
2.	Ring seal	156444	5330-00-237-6266	Fig. 27, item 2
3.	Locknut	S-222-A	N/A	Fig. 27, item 4
4.	Impeller locknut	F1801-040	5310-00-680-6874	Fig. 27, item 5
5.	Screw	194010	5305-00-411-9340	Fig. 27, item 9
6.	Diffuser plate	217736	2990-01-085-1622	Fig. 27, item 10
7.	O-ring	202456	5330-00-484-9937	Fig. 27, item 11
8.	Bearing insert pad	170510	5330-00-632-6182	Fig. 27, item 12
9.	Bearing	156420	3120-00-682-7706	Fig. 27, item 13
10.	Insulated packing	202377	5330-00-406-7789	Fig. 27, item 15
11.	Ring seal	3034736	5330-01-145-5374	Fig. 27, item 17

Table 11. WP 0027 00 Turbocharger HT-3B Mandatory Replacement Parts.

(1) ITEM NO.	(2) NOMENCLATURE	(3) PART NUMBER	(4) NATIONAL STOCK NUMBER	(5) REPAIR PARTS WP 0058 00
1.	Retaining ring	3709510	N/A	Fig. 28, item 1
2.	Seal ring	3521441	N/A	Fig. 28, item 5
3.	Seal ring	3521442	5330-01-303-1600	Fig. 28, item 6
4.	Sleeve bearing	3722366	N/A	Fig. 28, item 9
5.	Thrust collar	3521440	N/A	Fig. 28, item 10
6.	Locknut	3519471	5310-01-303-8583	Fig. 28, item 13
7.	Lockwasher	3521119	5310-01-497-2856	Fig. 28, item 14
8.	Retaining ring	3723863	N/A	Fig. 28, item 17
9.	Oil seal plate	3759618	5330-01-497-4872	Fig. 28, item 18
10.	Deflector	3521439	2815-01-497-6029	Fig. 28, item 19
11.	O-ring	3751948	N/A	Fig. 28, item 20
12.	Oil baffle	3519401	2520-01-497-7027	Fig. 28, item 21
13.	Thrust bearing	3519290	N/A	Fig. 28, item 22
14.	Retaining ring	3718373	5325-01-449-3299	Fig. 28, item 25
15.	Sleeve bushing	3757753	N/A	Fig. 28, item 28

MANDATORY REPLACEMENT PARTS (Contd)*Table 12. WP 0028 00 Front Gear Cover Mandatory Replacement Parts.*

(1) ITEM NO.	(2) NOMENCLATURE	(3) PART NUMBER	(4) NATIONAL STOCK NUMBER	(5) REPAIR PARTS WP 0058 00
1.	Oil seal	211255	5330-00-135-6382	Fig. 16, item 6
2.	Crankshaft oil seal	3020183	5330-01-240-1619	Fig. 4, item 11
3.	O-ring	215705	5331-01-145-0716	Fig. 16, item 5
4.	Sleeve bushing	132770	3120-00-877-2213	Fig. 16, item 2

Table 13. WP 0029 00 Accessory Drive and Accessory Drive Pulley Mandatory Replacement Parts.

(1) ITEM NO.	(2) NOMENCLATURE	(3) PART NUMBER	(4) NATIONAL STOCK NUMBER	(5) REPAIR PARTS WP 0058 00
1.	Sleeve	190397	2930-00-401-9531	Fig. 17, item 18
2.	Thrust bearing	3026557	3120-01-144-7368	Fig. 17, item 28
3.	Thrust bearing	3026556	3120-01-147-5275	Fig. 17, item 21
4.	Bushing	116391	3120-00-792-9834	Fig. 17, item 32

Table 14. WP 0030 00 Engine Retarder Mandatory Replacement Parts.

(1) ITEM NO.	(2) NOMENCLATURE	(3) PART NUMBER	(4) NATIONAL STOCK NUMBER	(5) REPAIR PARTS WP 0058 00
1.	Spring	001519	5360-01-089-9103	Fig. 18, item 21
2.	Spring	007500	5360-01-145-7555	Fig. 18, item 22
3.	Seal ring	001083	5330-01-086-6196	Fig. 18, item 7
4.	Seal ring	001082	5331-01-085-3105	Fig. 18, item 6
5.	Seal ring	20229	5331-01-086-1013	Fig. 18, item 5
6.	Spring	007447	5360-01-145-7607	Fig. 18, item 11
7.	Spring	001022	5360-01-084-9066	Fig. 18, item 17
8.	Locknut	001026	5310-01-157-3762	Fig. 18, item 8

MANDATORY REPLACEMENT PARTS (Contd)*Table 15. WP 0031 00 Air Compressor Mandatory Replacement Parts.*

(1) ITEM NO.	(2) NOMENCLATURE	(3) PART NUMBER	(4) NATIONAL STOCK NUMBER	(5) REPAIR PARTS WP 0058 00
1.	O-ring	128086	5331-00-441-0145	Fig. 20, item 50
2.	O-ring	127936	5331-00-941-3762	Fig. 20, item 49
3.	Spring	3023101	5360-01-086-3480	Fig. 20, item 47
4.	Spring	190334	5360-00-129-9415	Fig. 20, item 44
5.	Lockwasher	MS35338-45	5310-00-407-9566	Fig. 20, item 10
6.	Gasket	3047159	5330-00-131-7072	Fig. 20, item 13
7.	Gasket	154018	5330-00-852-7347	Fig. 20, item 15
8.	O-ring	211315	5330-01-060-9061	Fig. 20, item 43
9.	O-ring	128085	5331-00-905-2679	Fig. 20, item 41
10.	Spring	128080	5360-00-895-3216	Fig. 20, item 39
11.	Thrust bearing	211662	3120-01-129-7659	Fig. 20, item 36
12.	Lockwasher	MS35338-47	5310-00-2090-965	Fig. 20, item 33
13.	Gasket	176027	5330-00-129-9389	Fig. 20, item 32
14.	Retaining ring	119859	5325-00-922-9101	Fig. 20, item 21
15.	Piston ring	180810	2815-01-079-3290	Fig. 20, item 19
16.	Piston ring	1875350	N/A	Fig. 20, item 18
17.	Piston ring	650330	4310-01-079-5245	Fig. 20, item 17
18.	Bushing	3018153	3120-01-146-7196	Fig. 20, item 24
19.	Bearing	147610	3120-01-016-4883	Fig. 20, item 26
20.	Cap	191037	4310-01-084-7148	Fig. 20, item 48

Table 16. WP 0032 00 Fuel Injector Mandatory Replacement Parts

(1) ITEM NO.	(2) NOMENCLATURE	(3) PART NUMBER	(4) NATIONAL STOCK NUMBER	(5) REPAIR PARTS WP 0058 00
1.	Spring	166009	5360-00-132-0245	Fig. 21, item 9
2.	Gasket	193736	5330-00-132-0276	Fig. 21, item 11
3.	Filter screen	3008706	4730-01-077-2016	Fig. 21, item 17
4.	Gasket	173086	5330-00-132-0247	Fig. 21, item 18

MANDATORY REPLACEMENT PARTS (Contd)*Table 17. WP 0034 00 Solenoid Valve Mandatory Replacement Parts.*

(1) ITEM NO.	(2) NOMENCLATURE	(3) PART NUMBER	(4) NATIONAL STOCK NUMBER	(5) REPAIR PARTS WP 0058 00
1.	Retangular ring seal	129888	5331-00-081-9299	Fig. 29, item 9
2.	O-ring	190876	5331-00-132-0274	Fig. 29, item 11
3.	Shutoff valve spring	129768	5310-00-082-1888	Fig. 29, item 10
4.	Valve disc	3030970	4820-01-146-1048	Fig. 29, item 12

Table 18. WP 0035 00 Fuel Damper and Head Mandatory Replacement Parts.

(1) ITEM NO.	(2) NOMENCLATURE	(3) PART NUMBER	(4) NATIONAL STOCK NUMBER	(5) REPAIR PARTS WP 0058 00
1.	Retangular ring seal	139988	5331-00-809-3276	Fig. 31, item 6
2.	Retangular ring seal	100099	5331-00-809-2667	Fig. 31, item 8
3.	Fuel pump damper diaphragm	202897	5340-00-951-3536	Fig. 31, item 7
4.	Nylon washer	160514	5365-00-965-0870	Fig. 31, item 9

Table 19. WP 0036 00 Fuel Gear Pump Mandatory Replacement Parts.

(1) ITEM NO.	(2) NOMENCLATURE	(3) PART NUMBER	(4) NATIONAL STOCK NUMBER	(5) REPAIR PARTS WP 0058 00
1.	Lockwasher	181466	5310-00-484-1718	Fig. 25, item 8
2.	Gasket	3069017	5330-01-136-8569	Fig. 25, item 13
3.	Pressure Valve	3050624	4820-01-242-2579	Fig. 25, item 10
4.	Bearing sleeve	3033724	3120-01-215-9157	Fig. 25, item 17
5.	Dowel ring	3033719	3120-01-185-8586	Fig. 25, item 19

Table 20. WP 0037 00 Fuel Pump Governor Spring Mandatory Replacement Parts.

(1) ITEM NO.	(2) NOMENCLATURE	(3) PART NUMBER	(4) NATIONAL STOCK NUMBER	(5) REPAIR PARTS WP 0058 00
1.	Idling spring	3018767	5360-01-147-4846	Fig. 30, item 50
2.	Compression spring	143251	5360-00-461-5738	Fig. 30, item 47

MANDATORY REPLACEMENT PARTS (Contd)*Table 21. WP 0038 00 Fuel Pump Front Cover and Governor Mandatory Replacement Parts.*

(1) ITEM NO.	(2) NOMENCLATURE	(3) PART NUMBER	(4) NATIONAL STOCK NUMBER	(5) REPAIR PARTS WP 0058 00
1.	Spring	143848	5360-01-095-3661	Fig. 30, item 34
2.	Retaining ring	212604	5325-01-081-0662	Fig. 30, item 16
3.	Bearing	S-16052	3110-00-516-5289	Fig. 30, item 17
4.	Shaft seal	3045173	N/A	Fig. 30, item 21
5.	Seal	212603	5330-01-072-8828	Fig. 30, item 10
6.	Bushing	212609	3120-01-087-2539	Fig. 30, item 12
7.	Governor bushing	163944	3120-00-904-9595	Fig. 30, item 18

Table 22. WP 0039 00 Fuel Pump Main Housing Mandatory Replacement Parts.

(1) ITEM NO.	(2) NOMENCLATURE	(3) PART NUMBER	(4) NATIONAL STOCK NUMBER	(5) REPAIR PARTS WP 0058 00
1.	Retaining ring	MS16632-1050	5325-00-256-2846	Fig. 24, item 24
2.	O-ring	100478	5331-00-081-9289	Fig. 24, item 55
3.	Throttle shaft ball	213769	3110-01-079-8190	Fig. 24, item 57
4.	O-ring	213768	5331-01-072-8983	Fig. 24, item 52
5.	O-ring	68061-A	5331-00-970-3461	Fig. 24, item 14
6.	Cap seal ring	154088	5330-00-961-9470	Fig. 24, item 32
7.	Retaining ring	MS16629-1100	5325-00-558-9412	Fig. 24, item 18
8.	O-ring	193734	5330-00-403-9896	Fig. 24, item 21
9.	O-ring	145504	5330-01-051-4243	Fig. 24, item 20
10.	O-ring	145505	N/A	Fig. 24, item 19
11.	O-ring	100478	5331-00-081-9289	Fig. 24, item 55
12.	Gasket washer	3023870	5330-01-142-2784	Fig. 24, item 8
13.	Bellows	3013811	4820-01-079-3320	Fig. 24, item 10

MANDATORY REPLACEMENT PARTS (Contd)*Table 23. WP 0040 00 Fuel Pump Assembly Mandatory Replacement Parts.*

(1) ITEM NO.	(2) NOMENCLATURE	(3) PART NUMBER	(4) NATIONAL STOCK NUMBER	(5) REPAIR PARTS WP 0058 00
1.	Gasket	110855	5330-00-567-3463	Fig. 25, item 2
2.	Lockwasher	181466	5310-00-484-1718	Fig. 29, item 2
3.	Lockwasher	181466	5310-00-484-1718	Fig. 31, item 3
4.	Lockwasher	181466	5310-00-484-1718	Fig. 25, item 8
5.	Rectangular ring seal	691-10014	5330-00-252-8888	Fig. 31, item 16
6.	Rectangular ring seal	154087	5330-00-951-3538	Fig. 29, item 15
7.	Lockwasher	181466	5310-00-484-1718	Fig. 24, item 26
8.	Gasket	100764	5330-00-506-4866	Fig. 30, item 31
9.	Adjusting screw seal	3003156	5330-01-072-8830	Fig. 30, item 39
10.	Gasket	70705	5330-00-562-1176	Fig. 30, item 42
11.	Plastic bushing seal	Not listed	Not listed	Not listed

Table 24. WP 0041 00 Water Pump Mandatory Replacement Parts.

(1) ITEM NO.	(2) NOMENCLATURE	(3) PART NUMBER	(4) NATIONAL STOCK NUMBER	(5) REPAIR PARTS WP 0058 00
1.	Seat and seal	3071085	5330-00-005-0407	Fig. 36, item 3
2.	Seal	3038997	5330-01-240-1630	Fig. 36, item 6
3.	Bearing	3305L1A	3110-00-144-8828	Fig. 36, item 8
4.	Retaining ring	112302	5325-00-420-9696	Fig. 36, item 9
5.	Retaining ring	S16255	2815-00-815-0355	Fig. 36, item 11
6.	Seal	3038998	5330-01-080-2992	Fig. 36, item 12
7.	Sleeve	203097	3120-01-083-6411	Fig. 36, item 14
8.	Seal	3038998	5330-01-080-2992	Fig. 36, item 20
9.	Retaining ring	S-16255	2815-00-815-0355	Fig. 36, item 21
10.	O-ring	145506	5331-01-086-3991	Fig. 36, item 23
11.	Bearing	3305L1A	3110-00-144-8828	Fig. 36, item 24

MANDATORY REPLACEMENT PARTS (Contd)*Table 25. WP 0042 00 Cylinder Block Components Installation Mandatory Replacement Parts.*

(1) ITEM NO.	(2) NOMENCLATURE	(3) PART NUMBER	(4) NATIONAL STOCK NUMBER	(5) REPAIR PARTS WP 0058 00
1.	Gasket	3067616	5330-00-361-2955	Fig. 4, item 1
2.	Compression ring	3012331 (Part of 3801056)	2815-00-994-4427	Fig. 6, item 1
3.	Gasket	3099083	5330-01-147-0748	Fig. 12, item 1
4.	Lockwasher	116122	5310-00-011-6122	Fig. 20, item 1
5.	Compression ring	301233200 (Part of 3801056)	2815-01-241-6580	Fig. 6, item 2
6.	Piston ring	214730 (Part of 3801056)	2815-01-241-6581	Fig. 6, item 3
7.	Rear main seal	M39807	5330-00-005-0858	Fig. 4, item 4
8.	Thrust Bearing (standard)	3019218	3120-01-214-7779	Fig. 4, item 8
9.	Piston ring	3064398 (Part of 3801056)	2815-00-994-4429	Fig. 6, item 4
10.	Gasket	320-1850	5330-01-181-0631	Fig. 20, item 5
11.	Seal	137075	5331-00-420-9624	Fig. 4, item 5 (Big Cam III)
12.	O-ring	215705	5331-01-145-0716	Fig. 16, item 5
13.	Fourteen bearing halves– Main bearing set (standard)	3801260	3120-01-132-9339	Fig. 4, item 6
14.	Cam follower housing gasket (standard)	3074401	5330-01-145-3983	Fig. 7, item 8
15.	Lockwasher	S604	5310-00-261-7340	Fig. 7, item 9
16.	Gasket	3021704	5330-01-145-6914	Fig. 16, item 11
17.	Gasket	3201386	5330-01-181-0630	Fig. 19, item 11
18.	Connecting rod bearing halves – Bearing set (standard)	3725CP	3120-01-087-3004	Fig. 6, item 12
19.	Locknut	3012526	5310-01-126-1045	Fig. 17, item 13
20.	Keyway seal	3008947	5330-01-129-6541	Fig. 17, item 16
21.	Gasket	3069101	5330-00-026-2931	Fig. 17, item 19
22.	Lockplates	140218	5310-00-082-1882	Fig. 2, item 21
23.	Lockwasher	MS35338-47	5310-00-209-0965	Fig. 16, item 21
24.	Lockwasher	3011715	5305-01-072-8816	Fig. 16, item 22
25.	O-ring	172648	5330-00-404-2920	Fig. 5, item 27
26.	Lockwasher	MS35338-47	5310-00-209-0965	Fig. 13, item 27 (Big Cam I)

MANDATORY REPLACEMENT PARTS (Contd)*Table 25. WP 0042 00 Cylinder Block Components Installation Mandatory Replacement Parts (Contd).*

(1) ITEM NO.	(2) NOMENCLATURE	(3) PART NUMBER	(4) NATIONAL STOCK NUMBER	(5) REPAIR PARTS WP 0058 00
27.	Lockwasher	S-604	5310-00-261-7340	Fig. 13, item 27 (Big Cam III)
28.	Lockwasher	MS35338-46	5310-00-637-9541	Fig. 13, item 32
29.	Gasket	3029846	5330-01-145-6913	Fig. 13, item 34
30.	Lockwasher	MS35338-45	5310-00-407-9566	Fig. 12, item 40
31.	O-ring	3029847	5331-01-145-0715	Fig. 13, item 47
32.	Gasket	3031434	5330-01-147-4071	Fig. 13, item 49

Table 26. WP 0043 00 Cylinder Head and Cylinder Head Components Installation Mandatory Replacement Parts.

(1) ITEM NO.	(2) NOMENCLATURE	(3) PART NUMBER	(4) NATIONAL STOCK NUMBER	(5) REPAIR PARTS WP 0058 00
1.	O-ring	131026	5331-00-143-8485	Fig. 3, item 22
2.	Cylinder head gasket	3349819	5330-01-080-5021	Fig. 3, item 23
3.	Gasket	3017750	5330-00-861-8592	Fig. 8, item 32
4.	Gasket	3054841	5330-01-285-4827	Fig. 9, item 6
5.	Gasket	13294	5330-01-086-3996	Fig. 18, item 24
6.	O-ring	193736	5330-00-132-0276	Fig. 21, item 11

Table 27. WP 0044 00 Fuel Pump Testing and Calibration Mandatory Replacement Parts.

(1) ITEM NO.	(2) NOMENCLATURE	(3) PART NUMBER	(4) NATIONAL STOCK NUMBER	(5) REPAIR PARTS WP 0058 00
1.	Snapping	MS16625-1100	5325-00-807-2636	Fig. 30, item 43
2.	Gasket	70705	5330-00-562-1176	Fig. 30, item 42
3.	Throttle shaft cover plate	3000446	4320-01-098-5115	Fig. 24, item 56

MANDATORY REPLACEMENT PARTS (Contd)*Table 28. WP 0045 00 Engine Accessories Installation Mandatory Replacement Parts.*

(1) ITEM NO.	(2) NOMENCLATURE	(3) PART NUMBER	(4) NATIONAL STOCK NUMBER	(5) REPAIR PARTS WP 0058 00
1.	Gasket	3008591	5330-01-086-3523	Fig. 14, item 33
2.	Lockwasher	S-604	5310-00-261-7340	Fig. 14, item 25 (Big Cam I)
3.	Gasket	3035053	5330-01-160-7460	Fig. 23, item 8
4.	Lockwasher	MS122032	5310-00-159-6209	Fig. 14, item 13 (Big Cam III)
5.	Lockwasher	116122	5310-00-011-6122	Fig. 23, item 2 (Big Cam I)
6.	Lockwasher	S631	5310-00-562-6560	Fig. 24, item 3 (Big Cam III)
7.	Lockwasher	MS35338-46	5310-00-637-9541	Fig. 23, item 25 (Big Cam I)

Table 29. WP 0048 00 Big Cam III Engine Installation Mandatory Replacement Parts.

(1) ITEM NO.	(2) NOMENCLATURE	(3) PART NUMBER	(4) NATIONAL STOCK NUMBER	(5) REPAIR PARTS WP 0058 00
1.	Starter positive terminal lockwasher	MS35338-47	5310-00-209-0965	Fig. 33, item 2 TM 9-2320-283-24P
2.	Air cleaner housing locknut	M45913/ 1-4CG5C	5310-00-088-1251	Fig. 32, item 5 TM 9-2320-302-24P
3.	Hood hinge locknut	M45913/ 1-4CG5C	5310-00-088-1251	Fig. 205, item 7 TM 9-2320-302-24P
4.	Air cleaner housing bracket locknut	P52-6824	5310-01-347-7051	Fig. 32, item 9 TM 9-2320-302-24P
5.	Radiator support rod locknut	MS35338-67	5310-001-011-6121	Fig. 22, item 12 TM 9-2320-283-24P
6.	Air cleaner element	P15-3551	2940-01-333-0724	Fig. 32, item 15 TM 9-2320-302-24P
7.	Radiator crossmember mount locknut	9422305	5310-01-130-4274	Fig. 22, item 16 TM 9-2320-283-24P
8.	Starter ground terminal lockwasher	35510	5310-00-582-5965	Fig. 33, item 32 TM 9-2320-283-24P
9.	Transmission modulator cable clamp locknut	10218	5310-01-156-7841	Fig. 58, item 47 TM 9-2320-283-24P

MANDATORY REPLACEMENT PARTS (Contd)*Table 30. WP 0049 00 Big Cam I Engine Installation Mandatory Replacement Parts.*

(1) ITEM NO.	(2) NOMENCLATURE	(3) PART NUMBER	(4) NATIONAL STOCK NUMBER	(5) REPAIR PARTS WP 0058 00
1.	Ground strap starwasher	178551	5310-00-061-1258	Fig. 51, item 5 TM 9-2320-283-24P
2.	Alternator adjusting rod lockwasher	MS35338-47	5310-00-209-0965	Fig. 29, item 7 TM 9-2320-283-24P
3.	Drive belts	9451-2	3030-00-844-3603	Figure 29, item 9 TM 9-2320-283-24P
4.	Trunion retaining pin	MS24665-283	5315-00-842-3044	Fig. 58, item 30 TM 9-2320-283-24P
5.	Starter motor terminal lockwasher	35510	5310-00-582-5965	Fig. 33, item 32 TM 9-2320-283-24P
6.	Transmission shift control cable lockwasher	9421021	5310-01-096-6987	Fig. 58, item 35 TM 9-2320-283-24P
7.	Transmission shift control cable locknut	24617	5310-00-251-4503	Fig. 58, item 36 TM 9-2320-283-24P
8.	Transmission modular control bracket lockwasher	MS35340-49	5310-00-933-8123	Fig. 58, item 41 TM 9-2320-283-24P
9.	Transmission modulator control link retaining pin	MS24665-281	5315-00-839-2326	Fig. 58, item 50 TM 9-2320-283-24P

MANDATORY REPLACEMENT PARTS (Contd)*Table 31. WP 0046 00 Removing Engine from Maintenance Stand Mandatory Replacement Parts.*

(1) ITEM NO.	(2) NOMENCLATURE	(3) PART NUMBER	(4) NATIONAL STOCK NUMBER	(5) REPAIR PARTS WP 0058 00
1.	Gasket	70089-1	5330-00-537-2382	Fig. 11, item 3
2.	Water transfer hose	3031560	4720-01-085-2571	Fig. 11, item 5
3.	Gasket	70089-1	5330-00-537-2382	Fig. 2, item 13
4.	O-ring	3007442	5331-01-145-5377	Fig. 2, item 38
5.	Gasket	3008017	5330-01-079-6514	Fig. 11, item 39
6.	Lockwasher	3010596	5305-01-088-6019	Fig. 11, item 38
7.	Lockwasher	MS35338-48	5310-00-584-5272	Fig. 11, item 8
8.	Lockwasher	S-604	5310-00-261-7340	Fig. 10, item 31
9.	Gasket	3020943	5330-00-659-3178	Fig. 15, item 4
10.	Lockplate	114638	5310-00-887-8325	Fig. 15, item 8
11.	Lockplate	116982	5340-00-767-4012	Fig. 15, item 11
12.	Gasket	3069177	5330-00-194-8385	Fig. 26, item 8
13.	Hose	851-202994	4720-01-070-8149	Fig. 26, item 6
14.	Gasket	216487	5330-01-072-8998	Fig. 26, item 1
15.	Gasket	26384	5330-00-246-0309	Fig. 12, item 30
16.	Lockwasher	S-603	5310-00-820-6653	Fig. 12, item 17
17.	Lockwasher	MS35338-47	5310-00-209-0965	Fig. 12, item 34

INDEX

<u>Subject</u>	<u>WP Sequence No.-Page No.</u>
A	
Accessory Drive and Accessory Drive Pulley	WP 0029 00-1
Air Aftercooler	WP 0024 00-1
Air Compressor	WP 0031 00-1
B	
Big Cam I Engine Installation	WP 0049 00-1
Big Cam III Engine Installation	WP 0048 00-1
Big Cam I Engine Removal	WP 0007 00-1
Big Cam III Engine Removal	WP 0008 00-1
Block, Cylinder	WP 0013 00-1
C	
Camshaft, Camshaft Followers, and Pushrods	WP 0019 00-1
Cooler, Oil	WP 0021 00-1
Crankshaft Cleaning and Inspection	WP 0016 00-1
Cylinder Block	WP 0013 00-1
Cylinder Block Components Installation	WP 0042 00-1
Cylinder Block Components Removal	WP 0012 00-1
Cylinder Head	WP 0014 00-1
Cylinder Head and Cylinder Head Components Installation	WP 0043 00-1
Cylinder Head and Cylinder Head Components Removal	WP 0011 00-1
E	
Engine Accessories Removal	WP 0010 00-1
Engine Accessories Installation	WP 0045 00-1
Engine Installation, Big Cam I	WP 0049 00-1
Engine Installation, Big Cam III	WP 0048 00-1
Engine Removal, Big Cam I	WP 0007 00-1
Engine Removal, Big Cam III	WP 0008 00-1
Engine Retarder	WP 0030 00-1
Engine Testing	WP 0047 00-1
Equipment Description and Data	WP 0002 00-1
Exhaust Manifold	WP 0025 00-1
Expendable and Durable Items	WP 0060 00-1

INDEX (Contd)

<u>Subject</u>	<u>WP Sequence No.-Page No.</u>
F	
Flexplate, Flywheel, Flywheel Housing, and Rear Cover Cleaning and Inspection	WP 0017 00-1
Front Gear Cover	WP 0028 00-1
Fuel Damper and Head	WP 0035 00-1
Fuel Gear Pump	WP 0036 00-1
Fuel Injector	WP 0032 00-1
Fuel Pump Assembly	WP 0040 00-1
Fuel Pump Disassembly	WP 0033 00-1
Fuel Pump Front Cover and Governor	WP 0038 00-1
Fuel Pump Governor Spring	WP 0037 00-1
Fuel Pump Main Housing	WP 0039 00-1
Fuel Pump Testing and Calibration	WP 0044 00-1
G	
General Information	WP 0001 00-1
General Maintenance Instructions	WP 0051 00-1
I	
Illustrated List of Manufactured Items	WP 0052 00-1
M	
Mandatory Replacement Parts	WP 0062 00-1
Mounting Engine on Maintenance Stand	WP 0009 00-1
N	
National Stock Number (NSN) Index	WP 0059 00-1
O	
Oil Cooler	WP 0021 00-1
Oil Pan, Dipstick, Oil Suction Tubes, and Breather Tube	WP 0022 00-1
Oil Pump	WP 0023 00-1
P	
Pistons, Connecting Rods, and Bearings	WP 0018 00-1
Preventive Maintenance Checks and Services (PMCS) Introduction ..	WP 0005 00-1
Preventive Maintenance Checks and Services (PMCS) Instructions ..	WP 0006 00-1

INDEX (Contd)

<u>Subject</u>	<u>WP Sequence No.-Page No.</u>
R	
References	WP 0054 00-1
Removing Engine from Maintenance Stand	WP 0046 00-1
Repair Parts Introduction	WP 0056 00-1
Repair Parts Scope	WP 0057 00-1
Repair Parts and Special Tools List (RPSTL)	WP 0058 00-1
Rocker Levers and Rocker Lever Housing	WP 0020 00-1
S	
Solenoid Valve	WP 0034 00-1
T	
Theory of Operation	WP 0003 00-1
Tools and Special Tools	WP 0061 00-1
Torque Limits	WP 0052 00-1
Troubleshooting	WP 0004 00-1
Turbocharger	WP 0026 00-1
Turbocharger HT-3B	WP 0027 00-1
W	
Water Pump	WP 0041 00-1
Wear Limits	WP 0053 00-1

RECOMMENDED CHANGES TO PUBLICATIONS AND BLANK FORMS For use of this form, see AR 25-30; the proponent agency is ODISC4.	Use Part II (reverse) for Repair Parts and Special Tools Lists (RPSTL) and Supply Catalogs/Supply Manuals (SC/SM).	DATE: <p style="text-align: center;">1 January 2006</p>
---	--	---

TO: <i>(Forward to proponent of publication or form) (include ZIP code)</i> AMSTA-LC-CI Tech Pubs, TACOM-RI 1 Rock Island Arsenal Rock Island, IL 61299-7630	FROM: <i>(Activity and location) (include ZIP code)</i> Co. B, 1st BN, 2nd Brigade Ft. Hood, TX 76445
--	---

PART I - ALL PUBLICATIONS (EXCEPT RPSTL AND SC/SM) AND BLANK FORMS

PUBLICATION/FORM NUMBER <p style="text-align: center;">TM 9-2815-225-34&P</p>	DATE <p style="text-align: center;">21 July 2005</p>	TITLE <p style="text-align: center;">ENGINE, DIESEL: 6 CYLINDER IN-LINE TURBOCHARGED, CUMMINS MODEL NTC-400</p>
---	---	---

ITEM NO.	PAGE NO.	PARA-GRAPH	LINE NO.*	FIGURE NO.	TABLE NO.	RECOMMENDED CHANGES AND REASON <i>(Provide exact wording of recommended changes, if possible).</i>
	0007 00-3					Figure 3, Item X should show a flat washer. Currently shows a lockwasher.
	0007 00-9					Cleaning and inspection, step 5, reference to brush holder (8) is wrong reference. Reference should be changed to (10).
<h1 style="font-size: 4em; margin: 0;">SAMPLE</h1>						

**Reference to line numbers within the paragraph or subparagraph.*

TYPED NAME, GRADE, OR TITLE <p style="text-align: center;">Pat Smith</p>	TELEPHONE EXCHANGE/AUTOVON, PLUS EXTENSION <p style="text-align: center;">AV272-4162</p>	SIGNATURE <p style="text-align: center;"><i>Pat Smith</i></p>
--	--	--

TO: <i>(Forward direct to addressee listed in publication)</i> AMSTA-LC-CI Tech Pubs, TACOM-RI 1 Rock Island Arsenal Rock Island, IL 61299-7630	FROM: <i>(Activity and location)</i> <i>(include ZIP code)</i>	DATE:
--	---	-------

PART II - REPAIR PARTS AND SPECIAL TOOLS LISTS AND SUPPLY CATALOGS/SUPPLY MANUALS

PUBLICATION/FORM NUMBER TM 9-2815-225-34&P	DATE 21 July 2005	TITLE ENGINE, DIESEL: 6 CYLINDER IN-LINE TURBOCHARGED, CUMMINS MODEL NTC-400
---	----------------------	--

PAGE NO.	COLM NO.	LINE NO.	NATIONAL STOCK NUMBER	REFERENCE NO.	FIGURE NO.	ITEM NO.	TOTAL NO. OF MAJOR ITEMS SUPPORTED	RECOMMENDED ACTION
<h1>SAMPLE</h1>								

PART III - REMARKS *(Any general remarks or recommendations, or suggestions for improvement of publications and blank forms. Additional blank sheets may be used if more space is needed.)*

--	--	--

TYPED NAME, GRADE, OR TITLE	TELEPHONE EXCHANGE/AUTOVON, PLUS EXTENSION	SIGNATURE
-----------------------------	---	-----------

TO: <i>(Forward direct to addressee listed in publication)</i> AMSTA-LC-CI Tech Pubs, TACOM-RI 1 Rock Island Arsenal Rock Island, IL 61299-7630	FROM: <i>(Activity and location)</i> <i>(include ZIP code)</i>	DATE:
--	--	--------------

PART II - REPAIR PARTS AND SPECIAL TOOLS LISTS AND SUPPLY CATALOGS/SUPPLY MANUALS

PUBLICATION/FORM NUMBER TM 9-2815-225-34&P	DATE 21 July 2005	TITLE ENGINE, DIESEL: 6 CYLINDER IN-LINE TURBOCHARGED, CUMMINS MODEL NTC-400
---	-----------------------------	--

PAGE NO.	COLM NO.	LINE NO.	NATIONAL STOCK NUMBER	REFERENCE NO.	FIGURE NO.	ITEM NO.	TOTAL NO. OF MAJOR ITEMS SUPPORTED	RECOMMENDED ACTION

PART III - REMARKS *(Any general remarks or recommendations, or suggestions for improvement of publications and blank forms. Additional blank sheets may be used if more space is needed.)*

--

TYPED NAME, GRADE, OR TITLE	TELEPHONE EXCHANGE/AUTOVON, PLUS EXTENSION	SIGNATURE
------------------------------------	--	------------------

RECOMMENDED CHANGES TO PUBLICATIONS AND BLANK FORMS For use of this form, see AR 25-30; the proponent agency is ODISC4.	Use Part II (reverse) for Repair Parts and Special Tools Lists (RPSTL) and Supply Catalogs/Supply Manuals (SC/SM).	DATE:
---	--	-------

TO: <i>(Forward to proponent of publication or form) (include ZIP code)</i> AMSTA-LC-CI Tech Pubs, TACOM-RI 1 Rock Island Arsenal Rock Island, IL 61299-7630	FROM: <i>(Activity and location) (include ZIP code)</i>
--	---

PART I - ALL PUBLICATIONS (EXCEPT RPSTL AND SC/SM) AND BLANK FORMS

PUBLICATION/FORM NUMBER TM 9-2815-225-34&P	DATE 21 July 2005	TITLE ENGINE, DIESEL: 6 CYLINDER IN-LINE TURBOCHARGED, CUMMINS MODEL NTC-400
--	----------------------	--

ITEM NO.	PAGE NO.	PARA-GRAPH	LINE NO.*	FIGURE NO.	TABLE NO.	RECOMMENDED CHANGES AND REASON <i>(Provide exact wording of recommended changes, if possible).</i>

**Reference to line numbers within the paragraph or subparagraph.*

TYPED NAME, GRADE, OR TITLE	TELEPHONE EXCHANGE/AUTOVON, PLUS EXTENSION	SIGNATURE
-----------------------------	--	-----------

TO: <i>(Forward direct to addressee listed in publication)</i> AMSTA-LC-CI Tech Pubs, TACOM-RI 1 Rock Island Arsenal Rock Island, IL 61299-7630	FROM: <i>(Activity and location)</i> <i>(include ZIP code)</i>	DATE:
--	--	--------------

PART II - REPAIR PARTS AND SPECIAL TOOLS LISTS AND SUPPLY CATALOGS/SUPPLY MANUALS

PUBLICATION/FORM NUMBER TM 9-2815-225-34&P	DATE 21 July 2005	TITLE ENGINE, DIESEL: 6 CYLINDER IN-LINE TURBOCHARGED, CUMMINS MODEL NTC-400
---	-----------------------------	--

PAGE NO.	COLM NO.	LINE NO.	NATIONAL STOCK NUMBER	REFERENCE NO.	FIGURE NO.	ITEM NO.	TOTAL NO. OF MAJOR ITEMS SUPPORTED	RECOMMENDED ACTION

PART III - REMARKS *(Any general remarks or recommendations, or suggestions for improvement of publications and blank forms. Additional blank sheets may be used if more space is needed.)*

--

TYPED NAME, GRADE, OR TITLE	TELEPHONE EXCHANGE/AUTOVON, PLUS EXTENSION	SIGNATURE
------------------------------------	--	------------------

RECOMMENDED CHANGES TO PUBLICATIONS AND BLANK FORMS For use of this form, see AR 25-30; the proponent agency is ODISC4.	Use Part II (reverse) for Repair Parts and Special Tools Lists (RPSTL) and Supply Catalogs/Supply Manuals (SC/SM).	DATE:
---	--	-------

TO: <i>(Forward to proponent of publication or form) (include ZIP code)</i> AMSTA-LC-CI Tech Pubs, TACOM-RI 1 Rock Island Arsenal Rock Island, IL 61299-7630	FROM: <i>(Activity and location) (include ZIP code)</i>
--	---

PART I - ALL PUBLICATIONS (EXCEPT RPSTL AND SC/SM) AND BLANK FORMS

PUBLICATION/FORM NUMBER TM 9-2815-225-34&P	DATE 21 July 2005	TITLE ENGINE, DIESEL: 6 CYLINDER IN-LINE TURBOCHARGED, CUMMINS MODEL NTC-400
--	----------------------	--

ITEM NO.	PAGE NO.	PARA-GRAPH	LINE NO.*	FIGURE NO.	TABLE NO.	RECOMMENDED CHANGES AND REASON <i>(Provide exact wording of recommended changes, if possible).</i>

**Reference to line numbers within the paragraph or subparagraph.*

TYPED NAME, GRADE, OR TITLE	TELEPHONE EXCHANGE/AUTOVON, PLUS EXTENSION	SIGNATURE
-----------------------------	--	-----------

TO: <i>(Forward direct to addressee listed in publication)</i> AMSTA-LC-CI Tech Pubs, TACOM-RI 1 Rock Island Arsenal Rock Island, IL 61299-7630	FROM: <i>(Activity and location)</i> <i>(include ZIP code)</i>	DATE:
--	--	--------------

PART II - REPAIR PARTS AND SPECIAL TOOLS LISTS AND SUPPLY CATALOGS/SUPPLY MANUALS

PUBLICATION/FORM NUMBER TM 9-2815-225-34&P	DATE 21 July 2005	TITLE ENGINE, DIESEL: 6 CYLINDER IN-LINE TURBOCHARGED, CUMMINS MODEL NTC-400
---	-----------------------------	--

PAGE NO.	COLM NO.	LINE NO.	NATIONAL STOCK NUMBER	REFERENCE NO.	FIGURE NO.	ITEM NO.	TOTAL NO. OF MAJOR ITEMS SUPPORTED	RECOMMENDED ACTION

PART III - REMARKS *(Any general remarks or recommendations, or suggestions for improvement of publications and blank forms. Additional blank sheets may be used if more space is needed.)*

TYPED NAME, GRADE, OR TITLE	TELEPHONE EXCHANGE/AUTOVON, PLUS EXTENSION	SIGNATURE
------------------------------------	--	------------------

By Order of the Secretary of the Army:

PETER J. SCHOOMAKER
General, United States Army
Chief of Staff

Official:



SANDRA R. RILEY
Administrative Assistant to the
Secretary of the Army
0430611

Distribution:

To be distributed in accordance with the Initial Distribution Number (IDN) 371461 requirements for TM 9-2815-225-34&P.

THE METRIC SYSTEM AND EQUIVALENTS

LINEAR MEASURE

- 1 Centimeter = 10 Millimeters = 0.01 Meters = 0.3937 Inches
- 1 Meter = 100 Centimeters = 1,000 Millimeters = 39.37 Inches
- 1 Kilometer = 1,000 Meters = 0.621 Miles

SQUARE MEASURE

- 1 Sq Centimeter = 100 Sq Millimeters = 0.155 Sq Inches
- 1 Sq Meter = 10,000 Sq Centimeters = 10.76 Sq Feet
- 1 Sq Kilometer = 1,000,000 Sq Meters = 0.386 Sq Miles

CUBIC MEASURE

- 1 Cu Centimeter = 1,000 Cu Millimeters = 0.06 Cu Inches
- 1 Cu Meter = 1,000,000 Cu Centimeters = 35.31 Cu Feet

LIQUID MEASURE

- 1 Milliliter = 0.001 Liters = 0.0338 Fluid Ounces
- 1 Liter = 1,000 Milliliters = 33.82 Fluid Ounces

TEMPERATURE

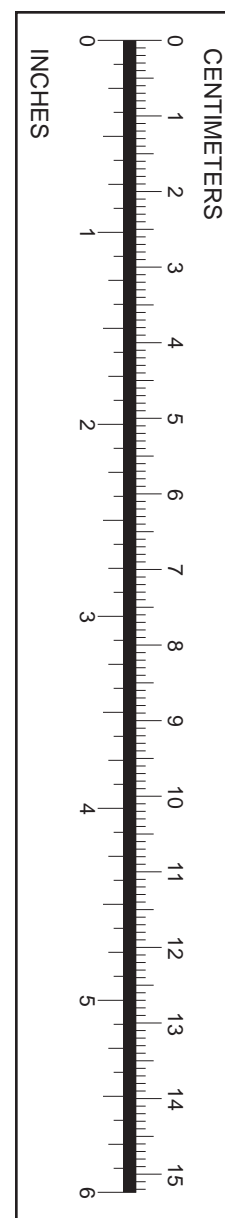
- $5/9 (^{\circ}\text{F} - 32) = ^{\circ}\text{C}$
- 212° Fahrenheit is equivalent to 100° Celsius
- 90° Fahrenheit is equivalent to 32.2° Celsius
- 32° Fahrenheit is equivalent to 0° Celsius
- $9/5 ^{\circ}\text{C} + 32 = ^{\circ}\text{F}$

WEIGHTS

- 1 Gram = 0.001 Kilograms = 1,000 Milligrams = 0.035 Ounces
- 1 Kilogram = 1,000 Grams = 2.2 Lb
- 1 Metric Ton = 1,000 Kilograms = 1 Megagram = 1.1 Short Tons

APPROXIMATE CONVERSION FACTORS

TO CHANGE	TO	MULTIPLY BY
Inches	Centimeters	2.540
Feet	Meters	0.305
Yards	Meters	0.914
Miles	Kilometers	1.609
Square Inches	Square Centimeters	6.451
Square Feet	Square Meters	0.093
Square Yards	Square Meters	0.836
Square Miles	Square Kilometers	2.590
Acres	Square Hectometers	0.405
Cubic Feet	Cubic Meters	0.028
Cubic Yards	Cubic Meters	0.765
Fluid Ounces	Milliliters	29.573
Pints	Liters	0.473
Quarts	Liters	0.946
Gallons	Liters	3.785
Ounces	Grams	28.349
Pounds	Kilograms	0.454
Short Tons	Metric Tons	0.907
Pound-Feet	Newton-Meters	1.356
Pounds Per Square Inch	Kilopascals	6.895
Miles Per Gallon	Kilometers Per Liter	0.425
Miles Per Hour	Kilometers Per Hour	1.609
TO CHANGE	TO	MULTIPLY BY
Centimeters	Inches	0.394
Meters	Feet	3.280
Meters	Yards	1.094
Kilometers	Miles	0.621
Square Centimeters	Square Inches	0.155
Square Meters	Square Feet	10.764
Square Meters	Square Yards	1.196
Square Kilometers	Square Miles	0.386
Square Hectometers	Acres	2.471
Cubic Meters	Cubic Feet	35.315
Cubic Meters	Cubic Yards	1.308
Milliliters	Fluid Ounces	0.034
Liters	Pints	2.113
Liters	Quarts	1.057
Liters	Gallons	0.264
Grams	Ounces	0.035
Kilograms	Pounds	2.205
Metric Tons	Short Tons	1.102
Newton-Meters	Pound-Feet	0.738
Kilopascals	Pounds Per Square Inch	0.145
Kilometers Per Liter	Miles Per Gallon	2.354
Kilometers Per Hour	Miles Per Hour	0.621



This fine document...

Was brought to you by me:



[Liberated Manuals -- free army and government manuals](#)

Why do I do it? I am tired of sleazy CD-ROM sellers, who take publicly available information, slap “watermarks” and other junk on it, and sell it. Those masters of search engine manipulation make sure that their sites that sell free information, come up first in search engines. They did not create it... They did not even scan it... Why should they get your money? Why are not letting you give those free manuals to your friends?

I am setting this document FREE. This document was made by the US Government and is NOT protected by Copyright. Feel free to share, republish, sell and so on.

I am not asking you for donations, fees or handouts. If you can, please provide a link to liberatedmanuals.com, so that free manuals come up first in search engines:

<A HREF=<http://www.liberatedmanuals.com/>>Free Military and Government Manuals

- Sincerely
Igor Chudov
<http://igor.chudov.com/>
- [Chicago Machinery Movers](#)